



MatGuard Mat Manager with MatGuard Pressure Sensitive Sensor Mats

Catalog Numbers 440F-C28011, 440F-C28012, 440F-C28013,
440F-C28023, 440F-C28024, 440F-C28025, 440F-C28026



Allen-Bradley

by ROCKWELL AUTOMATION

Guardmaster®

User Manual

Original Instructions

Important User Information

Read this document and the documents listed in the additional resources section about installation, configuration, and operation of this equipment before you install, configure, operate, or maintain this product. Users are required to familiarize themselves with installation and wiring instructions in addition to requirements of all applicable codes, laws, and standards.

Activities including installation, adjustments, putting into service, use, assembly, disassembly, and maintenance are required to be carried out by suitably trained personnel in accordance with applicable code of practice.

If this equipment is used in a manner not specified by the manufacturer, the protection provided by the equipment may be impaired.

In no event will Rockwell Automation, Inc. be responsible or liable for indirect or consequential damages resulting from the use or application of this equipment.

The examples and diagrams in this manual are included solely for illustrative purposes. Because of the many variables and requirements associated with any particular installation, Rockwell Automation, Inc. cannot assume responsibility or liability for actual use based on the examples and diagrams.

No patent liability is assumed by Rockwell Automation, Inc. with respect to use of information, circuits, equipment, or software described in this manual.

Reproduction of the contents of this manual, in whole or in part, without written permission of Rockwell Automation, Inc., is prohibited.

Throughout this manual, when necessary, we use notes to make you aware of safety considerations.



WARNING: Identifies information about practices or circumstances that can cause an explosion in a hazardous environment, which may lead to personal injury or death, property damage, or economic loss.



ATTENTION: Identifies information about practices or circumstances that can lead to personal injury or death, property damage, or economic loss. Attentions help you identify a hazard, avoid a hazard, and recognize the consequence.

IMPORTANT Identifies information that is critical for successful application and understanding of the product.

Labels may also be on or inside the equipment to provide specific precautions.



SHOCK HAZARD: Labels may be on or inside the equipment, for example, a drive or motor, to alert people that dangerous voltage may be present.



BURN HAZARD: Labels may be on or inside the equipment, for example, a drive or motor, to alert people that surfaces may reach dangerous temperatures.



ARC FLASH HAZARD: Labels may be on or inside the equipment, for example, a motor control center, to alert people to potential Arc Flash. Arc Flash will cause severe injury or death. Wear proper Personal Protective Equipment (PPE). Follow ALL Regulatory requirements for safe work practices and for Personal Protective Equipment (PPE).

Preface

Who Would Use This Manual	7
Safety Standards Applied to Pressure Sensitive Safety Mats	7
EMC Directives	8
Functional Safety Data	8
Safety Certification	8
Markings.....	8
Storage	9
Handling and Transport.....	9
Safety Mat Environmental and Operating Conditions	9
Possible Misuse.....	10
Summary of Changes.....	11
Additional Resources.....	11

Product Overview

Chapter 1

Introduction.....	13
System Components	13
MatGuard Mat Manager.....	13
Pressure Sensitive Safety Mats.....	14
Active Uniting Trim.....	14
Perimeter Trim.....	14
Safety Mat Functionality.....	14
MatGuard Mat Manager Functionality	15
Select the Mat Manager	15
Wiring the Mat Manager Safety Outputs	16

System Design

Chapter 2

Nature of Hazard	19
Nature of Safeguarding.....	19
Proper Positioning of Safety Mats	20
Combined Trip and Presence Sensing System	20
Presence Sensing System within a Guarded Perimeter	22
Fixed Guards	23
Design Practice and Measures Against Bypass	23
Safety Mat Pattern	24
Wear and Damage	25
Floor requirements.....	25
Mat Manager Mounting	25
Electrical Interface	26
Select the Power Supply	26
Interconnection to the Machine Safety Control Circuit.....	26
Reset Modes	27
Auxiliary Output.....	29
Arc Suppression	29
Final Safety Mat Layout.....	29
Wiring.....	29

Final Details	29
-------------------------	----

Install and Commission

Chapter 3

Safety Mat Installation	31
Safety Mat Dimensions	33
Active Uniting Trim Fixing	34
Perimeter Trim Fixing	34
Mat Manager Installation and Wiring	35
Mat Manager Enclosure Layout	36
Individual Safety Mat Connections	39
Safety Mat Selection	40
Safety Mat M12 QD Connections	41
Flying Lead Connections	42
Power and I/O Connector Diagrams	43
440F-C28011 and 440F-C28012 Mat Managers	43
440F-C28023 Mat Manager	45
440F-C28024 and 440F-C28025 Mat Managers	48
440F-C28026 Mat Manager	50
440F-C28013 Mat Manager	52
Reset Mode Selection	53
Check Mechanical Installation	53
Electrical Functions Check	54
Manual Reset Mode Only	54
Auto Reset Model Only	54
Functional Checkout	55

Maintenance

Chapter 4

Safety Mat Cleaning	57
Routine Inspection and Test	57
Thorough Inspection and Test	58
Dismantle and Dispose	58
Repair	59
Spare Parts	59
Service	59

Status Indicators and Troubleshooting

Chapter 5

Status Indicators	61
Internal Error	62
Faults	62
No Start	62
No Stop	63
Unexpected Stoppage	63

Specifications

Appendix A

MatGuard Mat Manager Specifications	65
Safety Mat Specifications	66
Mat Manager Dimensions	67
Spare Part List	68

Index	69
--------------------	----

Notes:

IMPORTANT Read this manual before installation. After installation, this manual must be retained in a safe and accessible place.

This manual is a reference guide for proper installation of the 440F-C28x MatGuard™ Mat Manager Controller in combination with the 440F-Mx MatGuard Pressure Sensitive Safety Mats. This manual describes the procedures to install, wire, and troubleshoot both components within the MatGuard Mat Manager safety system.

Who Would Use This Manual

Use this manual if you design, install, program, or troubleshoot systems that use the 440F-C28x MatGuard Mat Manager.

You must have a basic understanding of electrical circuitry and familiarity with safety-related systems. If you do not, obtain the proper training before using this product.

Qualified personnel must conduct all inspections and perform the following tasks:

- Undergo the appropriate technical training.
- Instruct personnel in the operation of the machine and the current safety guidelines.
- Read and have access to the user manual.

Safety Standards Applied to Pressure Sensitive Safety Mats

The following standards are referred to in this manual:

- ISO 12100: 2010 - Safety of machinery - General principles for design - Risk assessment and risk reduction.
- BS EN ISO 13857: 2019 - Safety of machinery - Safety distances to help prevent upper and lower limbs from reaching hazardous zones.
- ISO 14120: 2015 - Safety of machinery - Guards - General requirements for the design and construction of fixed and movable guards.
- ISO 13849-1: 2015: Safety of machinery - Safety-related parts of control systems - Part 1: General principles for design.
- ISO 13855: 2010 - Safety of machinery - Positioning of safeguards regarding the approach speeds of parts of the human body.
- ISO 13856-1: 2013 - Safety of machinery - Pressure-sensitive protective devices - Part 1: General principles for the design and testing of pressure-sensitive safety mats and pressure-sensitive floors.
- IEC 60204-1: 2016 - Safety of machinery - Electrical equipment of machines - Part 1: General requirements.
- IEC 62061: 2021 - Safety of machinery - Functional safety of safety-related electrical, electronic, and programmable electronic control systems.
- ANSI B11.TR3 - 2000 (2015): Risk Assessment and Risk Reduction-A guide to estimate, evaluate, and reduce risks that are associated with machine tools.

EMC Directives

The safety mat system complies with the requirements of Directives WEEE 2012/19/EU, EMC 2014/30/EU, and MD 2006/42/EC. Normal operation under interference conditions likely in industrial environments is confirmed and has been tested and certified.

Functional Safety Data

Compliance for the mat manager is achieved with the requirements of a category 3 per EN ISO 13856-1, PLd per ISO 13849-1, and SIL 2 per IEC 62061 regarding reliability and electrical faults and can be met for the associated part of the machine control system. Compliance for the safety mat sensors is achieved with the requirements of a category 1 per EN ISO 13856-1, and PLd to ISO 13849-1 in combination with the 440F-C28x MatGuard Mat Manager

Safety Certification

The type of safeguarding system must be suitable for the application for which it is intended. A documented process of risk assessment of the machinery or process reveals the identity and nature of the hazards together with other relevant information. The machinery manufacturer must conduct a risk assessment to determine the PL or SIL requirements.

The characteristics of the safeguarding system must then be compared with the results of the risk assessment to determine whether the risk can be reduced to an acceptable level. On some applications, to achieve an acceptable level of risk, it can be necessary to combine multiple types of safeguarding systems.

Markings

Figure 1 - Mat Manager Markings (440F-C2801xx)

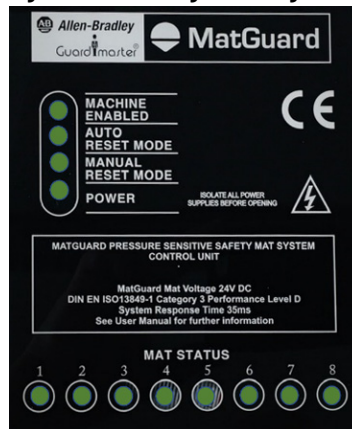

Figure 2 - MatGuard Pressure Sensitive Safety Mat Markings (440F-Mx)



Storage

The Guardmaster® mat manager and safety mat sensors must be stored within the temperature range -40...+70 °C (-40...+158 °F). The safety mats must be stored vertically.

Handling and Transport

The Guardmaster mat manager and safety mat sensors must be transported at a temperature of -40...+70 °C (-40...+158 °F). The original packaging or similar must be used together with stiffeners, if necessary, to protect from damage and flex. Always unpack carefully and avoid damage by sharp objects.

When safety mats are moved into position, never pull or lift the sensors by their connecting wires.

For the larger safety mats, two people are required for safe lifting and to help prevent a risk of damage to the safety mats from excessive flex.

Safety Mat Environmental and Operating Conditions

In general, the covering has excellent resistance to acids, alkalis, and salt. Hot acids, alkalis, and concentrated and organic acids, have a deleterious effect on prolonged exposure. The covering has fair resistance to aliphatic solvents, fair to poor resistance to aromatic and chlorinated solvents, and poor resistance to ketones and most esters.

Combinations of chemicals can have unpredictable effects. Tests are recommended in such cases. Small pieces of the vinyl material are available if tests are required.

Table 1 - Chemical Resistance of Safety Mat Covering

Substance	Safety Mat Resistance
Water (sea)	Excellent
Ethyl alcohol	Excellent
Sodium chloride	Excellent
Bleach	Excellent
Hydrochloric acid	Fair to excellent
Sulphuric acid	Fair to excellent
Nitric acid	Fair to excellent
Acetic acid	Fair
Petrol (gasoline)	Fair
Trichloroethylene	Fair to poor
Benzene	Poor
Acetone	Poor
Lubricating oil	Fair to excellent
Cutting fluids	Fair to excellent
Oil (auto)	Fair to excellent
Brake fluids	Poor to fair

Possible Misuse

The Guardmaster system is designed for the protection of personnel by sensing their presence on floor areas around machinery and other similar hazards.

The Guardmaster system must be used only within the specification limits given and must be installed strictly in accordance with the information that is provided in this manual.

The Guardmaster system alone does not provide protection against hazards that arise from the ejection of materials, gases, and radiation. For these applications, additional protective measures such as physical guards are required.

The Guardmaster system is not intended:

- For use as a perimeter only guard.
- For use as a machine initiation or reinitiation device.
- For use for use in explosive atmospheres.

IMPORTANT Special measures can be required in the presence of abnormally high levels of E.M.I. (for example, near to welding or induction heat equipment or near radio transmitters/transceivers).

The machine control circuit must be configured in a way that the closing of the Guardmaster system output contacts enables the starting circuit of the machine, but does not directly cause the machine to start up. The start or restart of the machine must only be possible by a separate and deliberate action at the designated machine controls.

Summary of Changes

This publication contains multiple changes throughout all chapters. Familiarize yourself with this manual and the related installation instructions before using your Guardmaster system or individual components.

Additional Resources

These documents contain additional information concerning related products from Rockwell Automation.

Resource	Description
Hazardous Location Switch Amplifiers with Safeguarding Devices Wiring Diagram, publication 937TH-WD001	Provides examples for how to connect safeguarding devices to isolating switch amplifiers.
Safety Mat and E-stop Control Using SmartGuard 600 Packaged Safety Controller Safety Application Example, publication SAFETY-AT008	Provides guidance on how to wire, configure, and program a SmartGuard™ 600 safety controller for use with a dual-channel safety mat and E-stop.
Safety Mat Control Using CompactBlock Guard I/O and GuardLogix Integrated Safety Controller Safety Application Example, publication SAFETY-AT011	Provides guidance on how to wire, configure, and program a GuardLogix® integrated safety controller with a CompactBlock™ Guard I/O™ module for use with a dual-channel safety mat and E-stop.
Safety Mat Stop Safety Function Application Technique, publication SAFETY-AT118	Explains how to wire, configure, and program a compact GuardLogix controller and POINT Guard I/O™ module to monitor a 440F safety mat.
Safety Function: Safety Mat Stop Application Technique, publication SAFETY-AT122	Explains how to wire and configure a Guardmaster dual-input safety relay (GSR DI) to monitor a pair of 440F safety mats and an E-stop.
Safety Mat Stop via a GuardLogix Controller Safety Function Application Technique, publication SAFETY-AT159	Explains how to wire, configure, and program a compact GuardLogix controller and POINT Guard I/O module to monitor a 440F safety mat.
System Security Design Guidelines Reference Manual, publication SECURE-RM001	Provides guidance on how to conduct security assessments, implement Rockwell Automation® products in a secure system, harden the control system, manage user access, and dispose of equipment.
UL Standards Listing for Industrial Control Products, publication CMPNTS-SR002	Assists original equipment manufacturers (OEMs) with construction of panels to conform to the requirements of Underwriters Laboratories.
American Standards, Configurations, and Ratings: Introduction to Motor Circuit Design, publication IC-AT001	Provides an overview of American motor circuit design, which is based on methods that are outlined in the NEC.
Industrial Components Preventive Maintenance, Enclosures, and Contact Ratings Specifications, publication IC-TD002	Provides a quick reference tool for Allen-Bradley® industrial automation controls and assemblies.
Safety Guidelines for the Application, Installation, and Maintenance of Solid-state Control, publication SGI-1.1	Designed to harmonize with NEMA Standards Publication No. ICS 1.1-1987 and provides general guidelines for the application, installation, and maintenance of solid-state control in the form of individual devices or packaged assemblies that incorporate solid-state components.
Industrial Automation Wiring and Grounding Guidelines, publication 1770-4.1	Provides general guidelines for installing a Rockwell Automation industrial system.
Product Certifications website, rok.auto/certifications .	Provides declarations of conformity, certificates, and other certification details.

You can view or download publications at rok.auto/literature.

Notes:

Product Overview

Introduction

When designed by professional personnel for use as a safety product in an industrial environment, the Guardmaster® MatGuard™ Mat Manager system provides protection against risks that the isolation of electrical power can eliminate when an operator is in the vicinity of the hazard. This manual covers the installation and use of all components of the Allen-Bradley® Guardmaster system. Only suitably trained and qualified personnel can conduct all installation procedures, which must be in accordance with statutory requirements for safety.

System Components

The Guardmaster MatGuard Mat Manager system is composed of a mat manager, one or more interconnected pressure sensitive safety mats, active uniting trim, and perimeter trim, as shown in [Figure 3](#).

Figure 3 - Basic System

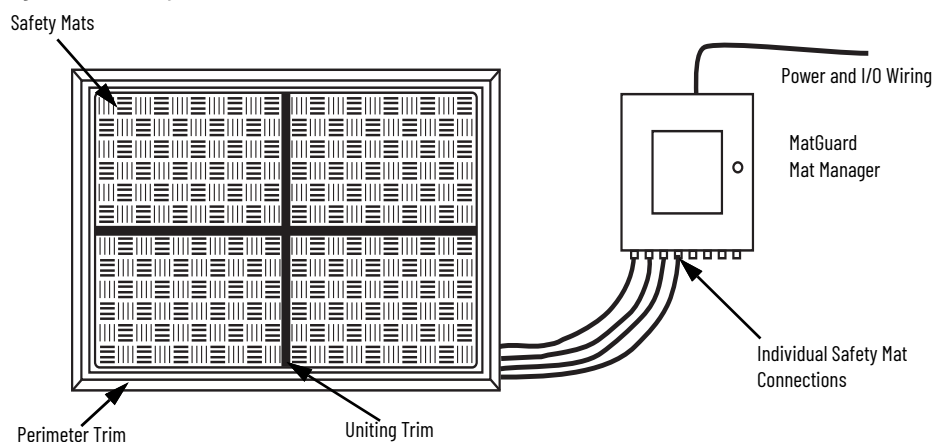

MatGuard Mat Manager

The mat manager provides connections for eight individual safety mats. The mat manager monitors the safety mats and deactivates outputs when a person is detected.



Pressure Sensitive Safety Mats

Pressure sensitive safety mats are designed to detect persons on their surface. Individual safety mat sections are available in rectangular standard sizes and also in specially cut shapes, up to the size of the largest standard safety mat.

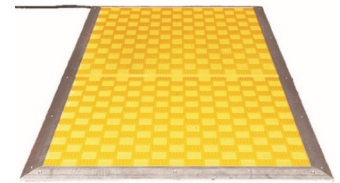

Active Uniting Trim

Active uniting trim is installed between adjacent safety mats to detect individuals present on the junction of the safety mats. There are no dead areas within the detection zone when safety mats are properly installed.

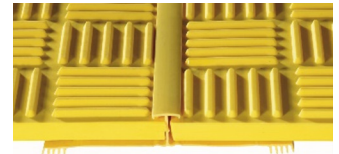

Perimeter Trim

Perimeter trim is used around the edges of the safety mats to hold the safety mats in place and to help prevent trip hazards. Various lengths and corner pieces are available to fit the safety mat area.



Safety Mat Functionality

All safety mats have the same construction and operation principle. Each safety mat has two conductive plates that are held apart by non-conductive compressible separators. The operating principle of the safety mat is shown in [Figure 4](#) and [Figure 5 on page 15](#).

Figure 4 - Safety Mat at Reset

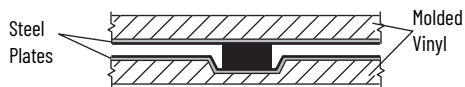

Each safety mat has four attached wires that operate at 24V DC and connect in series. Safety mats are available with Micro QD connections or flying lead cables. Your catalog selection defines the exit points on the safety mat wiring.

When the safety mat is activated, the non-conductive compressible separators (shown as black) compress into their recess, which allows the two plates to make contact.

Figure 5 - Safety Mat Activated

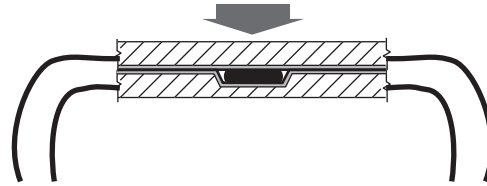

Safety mat wiring is connected directly to the mat manager, which monitors the individual safety mat connections.

You can arrange multiple safety mats around the machinery and, depending on the configuration, safety mats can be wired in series to protect a large area, see [Safety Mat Installation on page 31](#). Also see [Safety Mat Specifications on page 66](#) for connected capacitance per channel when safety mats are connected in a series.

The Guardmaster system is intended for the detection of adult persons with a weight of 35 kg (77.16 lb) or more and is suitable for the detection of adults with walking aids (for example, walking sticks or frames). The Guardmaster system forms a floor-level sensing system for hazardous areas around machinery.

IMPORTANT The system is not suitable for the detection of children. The system must not be used with any additional covering on the safety mat.

MatGuard Mat Manager Functionality

MatGuard Mat Manager is designed to accept up to eight individual safety mats. The Guardmaster Mat Manager monitors the 24V DC series circuit through each of the connected safety mats. The mat manager monitors each channel and provides a status indication of each connected safety mat.

When the protective area is clear, the mat manager provides a signal to the machine control circuit to allow the machine to start.

When the protective area is not clear (personnel is present stepping on a safety mat), the conductive plates touch in the safety mat and the resistance in the circuit drops. The mat manager monitors this action and turns the output off to initiate the machine shut-down sequence. Any single electrical fault in the safety mat, wiring, or mat manager is detected and the mat manager outputs goes to a safe (off) state.

Select the Mat Manager

The available control voltage, the required safety mat connections, the number of required safety outputs, and preference for machine safety circuit interconnection determine the correct mat manager for your application. See [Table 2 on page 16](#) for connection types.

IMPORTANT Safety mats must match the connection type of the controller unit.

Table 2 - MatGuard Mat Managers

Cat. No.	Power Required (1)	Safety Mat Connector	Safety Outputs	Auxiliary Outputs	Output Current [A]	Power/I/O Connector Type	Manual Reset Button (2)
440F-C28011	24V DC	(8) M12 Micro QD 4-pin	2 N.O.	1 N.C.	4 A	Brad Harrison 12-pin	No
440F-C28012	115/230V AC	(8) M12 Micro QD 4-pin	2 N.O.	1 N.C.	4 A	Brad Harrison 12-pin	No
440F-C28013	24V DC, 115/230V AC	(8) M12 Micro QD 4-pin	2 N.O.	1 N.C.	4 A	Terminal strip	Yes
440F-C28023	115/230V AC	(8) M12 Micro QD 4-pin	6 N.O.	1 N.O.	4 A	Harting 24-pin	No
440F-C28024	24V DC	(8) Cord grips (3)	2 N.O.	1 N.C.	2 A	M12 QD 8-pin	Yes
440F-C28025	24V DC	(8) Cord grips (3)	2 N.O.	1 N.C.	2 A	M12 QD 8-pin	No
440F-C28026	24V DC	(8) M12 Micro QD 4-pin	2 N.O.	1 N.C.	-	M23 QD 12-pin	No

(1) Supplied through the Power/I/O Connector.
 (2) Mounted on enclosure (front).
 (3) Accepts flying leads from the safety mat.

Mat managers are available with two different safety mat connector types:

- Enclosure-mounted Cord Grips:**
 Use this connection type to connect safety mats (up to eight) with standard cables, without connectors (flying leads). Safety mat cables end directly to the main control board.
- Enclosure-mounted M12 Micro QD connectors:**
 This connection type is ideal for easy installation and quick replacement if individual (up to eight) safety mats are ever damaged. Use when safety mats are supplied with M12 connectors.



Wiring the Mat Manager Safety Outputs

The MatGuard Mat Manager connects into the machine safety circuit through the power and I/O connector on the top side of the enclosure. For units without a power and I/O connector, termination occurs directly to the main control board terminal connection. See [Install and Commission on page 31](#).

Safety output contacts are wired into the machine safety circuit, which defines the overall performance of the safety system. [Figure 6 on page 17](#) is a typical illustration of the specific wiring required. See [Mat Manager Installation and Wiring on page 35](#) for details on your specific unit.

Figure 6 - Safety Mat System, Automatic Reset, Dual-channel Output, and Output Monitoring

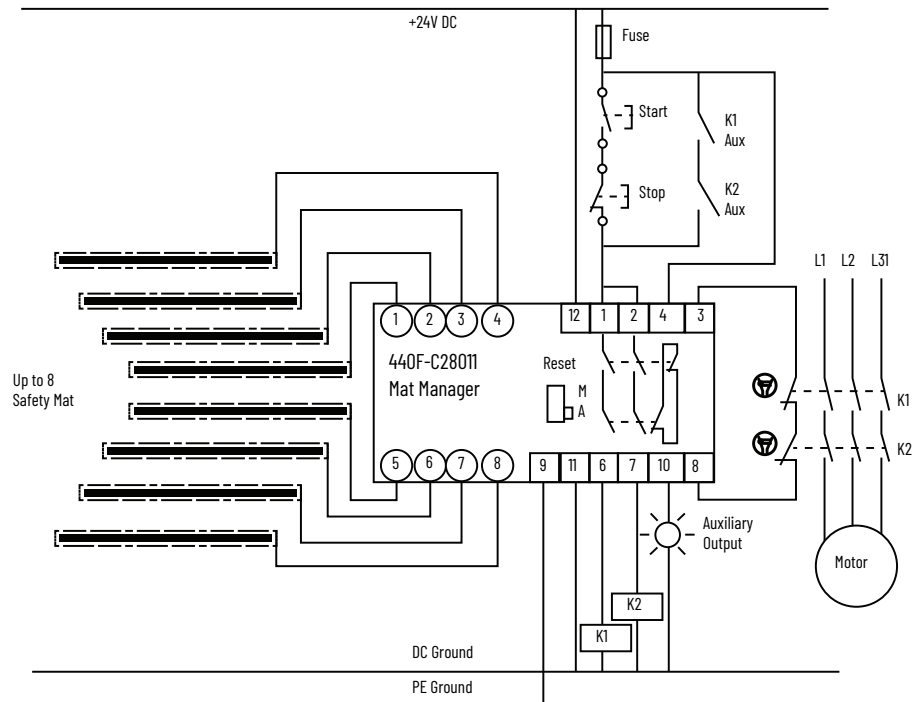

The machine safety circuit includes various I/O control components:

- Bulletin 800F and 800T operators: Panel operators for starting, stopping, fault resetting.
- Bulletin 100S safety contactors: For isolation and control of motor rated contactors.

When the system is wired as described previously, the expected operation is:

- When the protective area is clear, the mat manager provides a signal to the machine control circuit to allow the machine to start.
- When the protective area is not clear (a person steps on a safety mat), the conductive plates touch and the resistance drops in the circuit. The mat manager monitors this action and turns the output off to initiate the machine shut-down sequence. Any single electrical fault in the safety mat, wiring, or mat manager is detected and the mat manager outputs goes to a safe (off) state.

Notes:

System Design

We recommend that only personnel with experience in safety-related control system design, and who are suitably competent in electrical and mechanical engineering, design the system.

Nature of Hazard

The Guardmaster® system provides protection against such risks that can be minimized by the isolation of electrical power when an operator is in the vicinity of the hazard. Additional measures can be required to deal with other hazards that are identified at a risk assessment (for example, part ejection and hot surfaces). These measures can include fixed guards, interlocked guards, and warning notices.

IMPORTANT The risk assessment is included in ISO 12100-2010 and detailed in ANSI B11.TR3 2000 (2015).

Nature of Safeguarding

The system design must satisfy three main requirements:

1. The machine must stop if a person is in a position of being able to reach into the hazardous zone.
2. The machine must come to a stop before an approaching person can be in the position of being able to reach into the hazardous zone.
3. The system must not be easily bypassed.

The recommended use of the Guardmaster system gives presence sensing over the whole area where access is possible to the hazard (see the examples in [Figure 7](#)). Other uses of the Guardmaster system, for example, solely as a perimeter access guard, or as a machine enabling device, are not recommended.

Figure 7 - Layout Examples

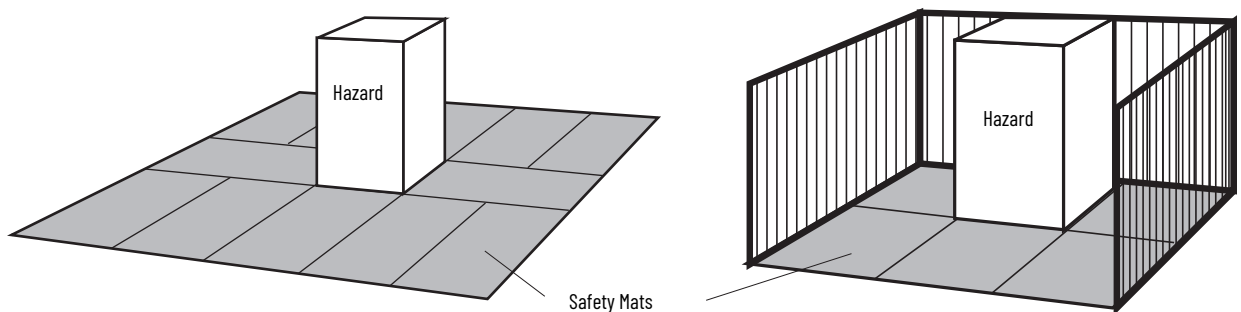

Proper Positioning of Safety Mats

The position of the safety mats depends on the use case. Safety mats can be used as:

- Combined trip and presence sensing devices.
- Presence sensing systems within a perimeter guarded area.

Combined Trip and Presence Sensing System

The positioning of the safety mat edges is calculated as a horizontal distance from the hazardous zone. Define the hazardous zone as a volume, with consideration of all possible modes of the machine and all variations in the size of the workplace. To check the adequacy of the safeguards, record the dimensions and position of the hazardous zone and the use case assumptions.

If other safeguard measures are used with the Guardmaster system, they can affect the requirements for the size and position of the safety mats, as shown in [Figure 8](#).

Figure 8 - Safety Mat Access (arrows show access)

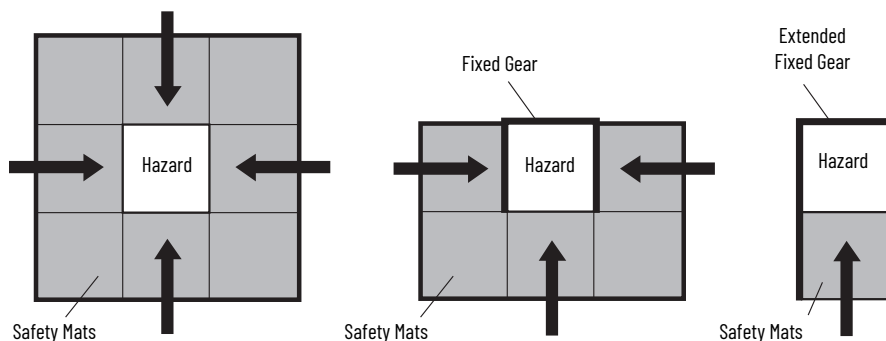

Safety mat position requirements:

- Determine the safe distance to the hazard -
There must be sufficient space to allow the minimum distance from the hazard to the accessible safety mat perimeter to be in accordance with ISO 13855 safety distance calculations. See [Figure 9 on page 21](#).
- Full coverage of safety mats around the hazard -
Safety mats must cover the entire floor area between the defined perimeter and the hazard so that it is not possible to approach or stand in the vicinity of the hazard without actuating the Guardmaster system.

Determine the proper safety mat position:

1. Determine the routes where unobstructed access to the hazardous zone is required across the Guardmaster safety mats. Consider:
 - All routine needs for access, such as product inspection, machine inspection and adjustment, tool changes, and clearing blockages.
 - Visual observation of the process.
 - Space requirements of people and ancillary equipment close to the machine during interventions.
2. There must be sufficient space to allow the minimum distance from the hazard to the accessible safety mat perimeter, in accordance with the safety distance calculations (see [Figure 9 on page 21](#)). Applications that use the Guardmaster system as a combined trip and presence sensing

system must be in accordance with ISO 13855. [Figure 9](#) shows the essential steps.

IMPORTANT If your machine is designed to conform to an existing harmonized European C type standard, which gives more specific formulas or minimum distances, then use those values instead of the values that are given in ISO 13855.

- Safety mat sensors must cover the entire floor area between the defined perimeter and the hazard so that it is not possible to approach, or be in the vicinity of, the hazard without actuating the Guardmaster system.

Figure 9 - Safety Distance Calculation Steps

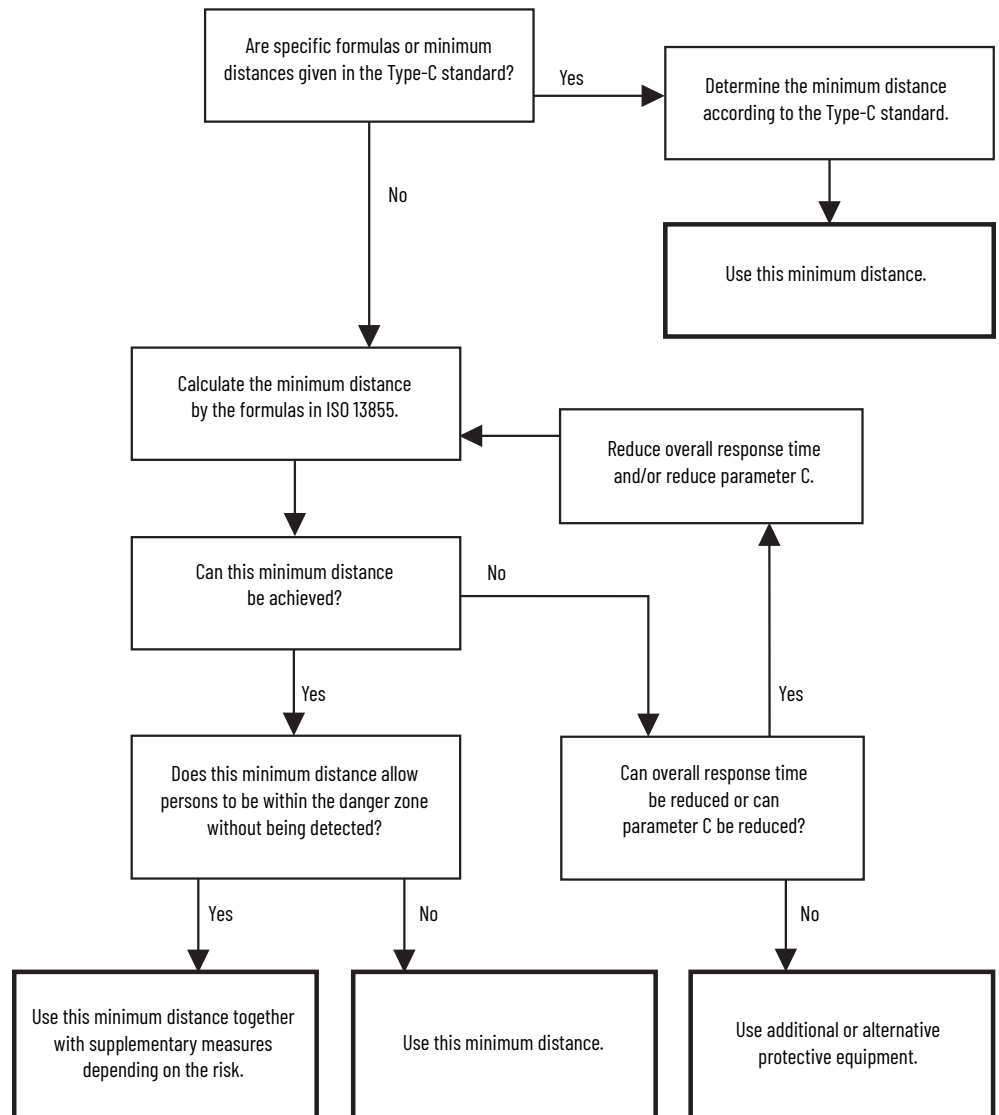

The calculated minimum distance is the minimum horizontal distance from the outer edge of the Guardmaster safety mat detection zone to the nearest part of the hazard.

The ISO 13855 formula for floor-mounted safety mats is:

$$S = (1600 \times T) + 1200 \text{ mm}$$

- S is the minimum safety distance in millimeters.

- The factor of 1600 is based on the standard assumption of 1600 mm/s (63 in./s) as the approach speed.
- T is the overall stopping time in seconds.
- The added 1200 mm (47.24 in.) is parameter C given in ISO 13855 and considers the stride length and arm reach.

The overall stopping time T is composed of two parts:

$$T = t_1 + t_2$$

- t_1 is the maximum time between actuation of the sensing function and the output signal switching.
For the Guardmaster system, $t_1 = 35$ ms.
- t_2 is the response time of the machine (the time that is required to stop the machine or remove the risks after receiving the output from the Guardmaster system).

The response time of the machine that is used in the calculation must be the worst case time. Some machines have inconsistent response times that are dependent upon the mode of operation, the nature of the workplace, and the point in the operating cycle at which stopping is initiated. An allowance must be made for delays, such as the wear in of brakes, if it can affect the response time. An allowance for further delays in the machine control system can be required in some circumstances.

Calculation Example

In this example, the Guardmaster system is used with a machine with a worst case response time measured as 0.485 seconds.

Using the formula	$T = t_1 + t_2$
	$= 35 \text{ ms} + 485 \text{ ms}$
	$= 520 \text{ ms} = 0.520 \text{ s}$
	$S = (1600 \times 0.520) + 1200 \text{ mm}$
	$= 832 + 1200 \text{ mm} = 2032 \text{ mm}$

Safety mats are required from 2032 mm (80 in.) right up to the edge of the machine base plate.

Presence Sensing System within a Guarded Perimeter

If the area around the hazard is enclosed within a guarded perimeter, as shown in [Figure 10 on page 23](#), the requirements of ISO 13855 Safe Distance Requirements do not necessarily apply. In these applications, the Guardmaster system detects the presence of an operator to help prevent the perimeter-guarding system from being reset and the machine from being restarted while the operator is inside the enclosure.

Figure 10 - Guarded Perimeter

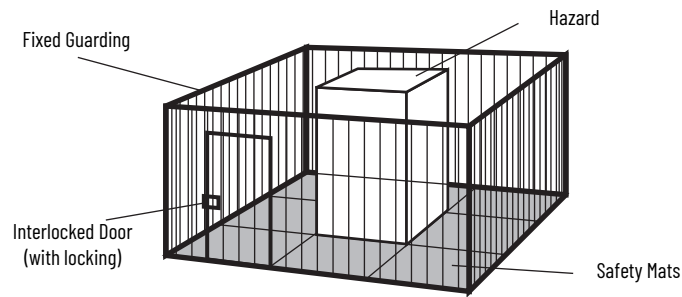

A suitable perimeter-guarding system would be a fixed guard with an access door that is fitted with an interlock switch with conditional guard unlocking (see ISO 14119). A trip device, such as a safety light curtain, is also suitable for some applications. The position of the light curtain must be calculated according to ISO 13855.

When using the MatGuard™ pressure sensitive safety mat in these applications, safety mats must cover the entire enclosed floor area between the enclosed perimeter and the hazard. It must not be possible for personnel to be in the enclosed area when activating the Guardmaster system.

IMPORTANT When the Guardmaster system is used as a secondary protective system, safety distance calculations are not applicable.

Safety mat position requirements:

- Perimeter-guarding -
The perimeter-guarding method must conform with all relevant requirements.
- Full coverage of safety mats around the hazard -
Safety mats must cover the entire floor area between the defined perimeter and the hazard so that it is not possible to approach or stand in the vicinity of the hazard without actuating the Guardmaster system.

Fixed Guards

The fixed guards must be designed so that access is not possible to the hazardous zone other than via the Guardmaster safety mats. Guard construction and position must be in accordance with EN ISO 14120 and ISO 13857.

Design Practice and Measures Against Bypass

It must not be possible to reach the hazard without standing on the Guardmaster safety mats. Access to the hazardous zone from positions that do not involve standing on the Guardmaster safety mats must be minimized. This configuration typically requires additional angle plates and careful positioning of cable troughs. Good practice is illustrated in [Figure 11 on page 24](#).

Figure 11 - Good Design Practice

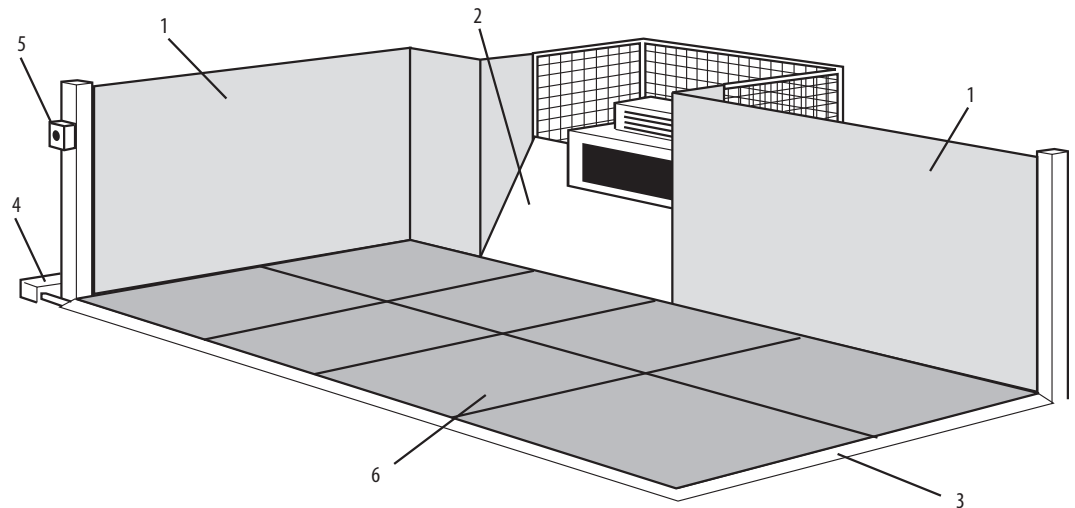

Item	Description
1	Fixed guards help prevent access to the hazardous zone so that there is no access between the guard and sensors.
2	A sloping cover plate helps prevent the operator from avoiding the sensing area by standing on the machine base plate.
3	A ramp at the point of access reduces the tripping hazard at the sensor edge. The ramp can also help protect cable connections. The Guardmaster perimeter trim is a ramp section.
4	Cable troughs are installed outside of the fixed guard. This configuration helps prevent misuse as access to the hazardous zone.
5	A Reset button is in a well-protected location with full visibility of the machine.
6	Safety mats are properly installed.

Safety Mat Pattern

The Guardmaster safety mat has two different rib patterns as shown in [Figure 12 on page 25](#). Either pattern can be used as the upper surface. Identify which side of the safety mat must face upward.

Both Guardmaster safety mat patterns provide a non-slip surface under most conditions, but must be kept free from large deposits of grease, soaps, or gels. If the straight rib side is uppermost, we recommend that the ribs run across the hazard to give improved grip.

The vinyl outer surface of the safety mat is sealed to resist the ingress of liquids and rated to IP67. Safety mats resist bleaches, acids, salt, and most industrial chemicals. See [Table 1 on page 10](#).

Figure 12 - Rib Pattern

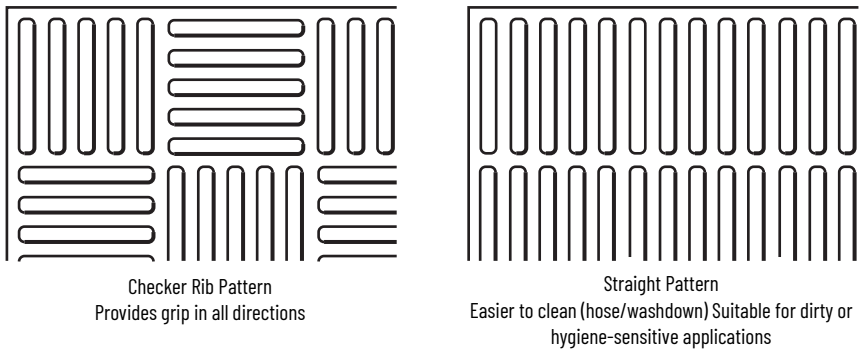

Wear and Damage

Impacts from sharp or heavy objects can damage the outer surface of the safety mat. After every such event, the safety mat must be inspected for deformation or puncture and replaced, if necessary.

Guardmaster safety mats are designed and tested to withstand one million operations in any one spot. In use, this number of operations in one location must not be exceeded. Occasional heavy loads (for example, up to three-ton trucks), are unlikely to damage the Guardmaster safety mats, but the safety mats must not be used on traffic through routes.

Floor requirements

The floor or mounting surface for the Guardmaster safety mats must be flat, smooth, and rigid, as shown in [Figure 13](#). The floor or mounting surface must show no perceptible distortion under the heaviest load anticipated.

Undulations, protrusions, large gaps, or other irregularities increase the sensitivity of the safety mats and can result in intermittent unintended switching off (nuisance tripping).

Small and regular protrusions, such as checker plate pattern, are acceptable. Skimmed concrete floors are ideal.

Figure 13 - Floor Conditions



Mat Manager Mounting

IMPORTANT The mat manager must not be mounted within the detection zone.

If access to the mat manager is required for manual reset or routine indicator observation, it must be mounted at an accessible position outside the protection zone that provides a good view of the hazard and protection zone.

In other cases, the mat manager can be mounted anywhere convenient outside the protection zone, with consideration of access requirements for tests and maintenance.

IMPORTANT The mat manager is not suitable for direct exposure to high-pressure cleaning.

Electrical Interface

The protection that is provided by the Guardmaster system depends on the correct interfacing between the Guardmaster system and the machine.

The safety output contacts from the Guardmaster mat manager are arranged as independent voltage-free N.O. contact pairs. The terminal positions are given in [Mat Manager Installation and Wiring on page 35](#) and ratings are given in [Specifications on page 65](#).

IMPORTANT Duplex sleeves are required if two wires are connected to one terminal.

The Guardmaster system can be used as the sole protective measure or in combination with other measures or devices (for example, a safety light curtain, system of work).

Select the Power Supply

The Guardmaster MatGuard™ Mat Manager offer two possibilities for power supply. Check that the power supply parameters conform to the requirements of the Guardmaster system as given in the specification. Where a 24V DC supply is used, it must be isolated from the mains supply in accordance with international electrical safety practice (IEC 364-4-41). One pole must be earthed (negative to be earthed for DC supplies).

Interconnection to the Machine Safety Control Circuit

[Figure 14 on page 27](#) shows an example connection diagram for the 440F-C28011 mat manager. The circuit conditions are as follows: Supply power is on, there is no presence on the safety mats, the normally open safety outputs are open, and the loads are energized. The mat manager is configured for monitored manual reset. Press and release the Reset button to energize the loads. If personnel step on any of the safety mats, the safety outputs open and power to the loads is removed. After stepping off the safety mat, the Reset button must be pressed and released to re-energize the loads.

Figure 14 - Connection Diagram for 440F-C28011 Mat Manager

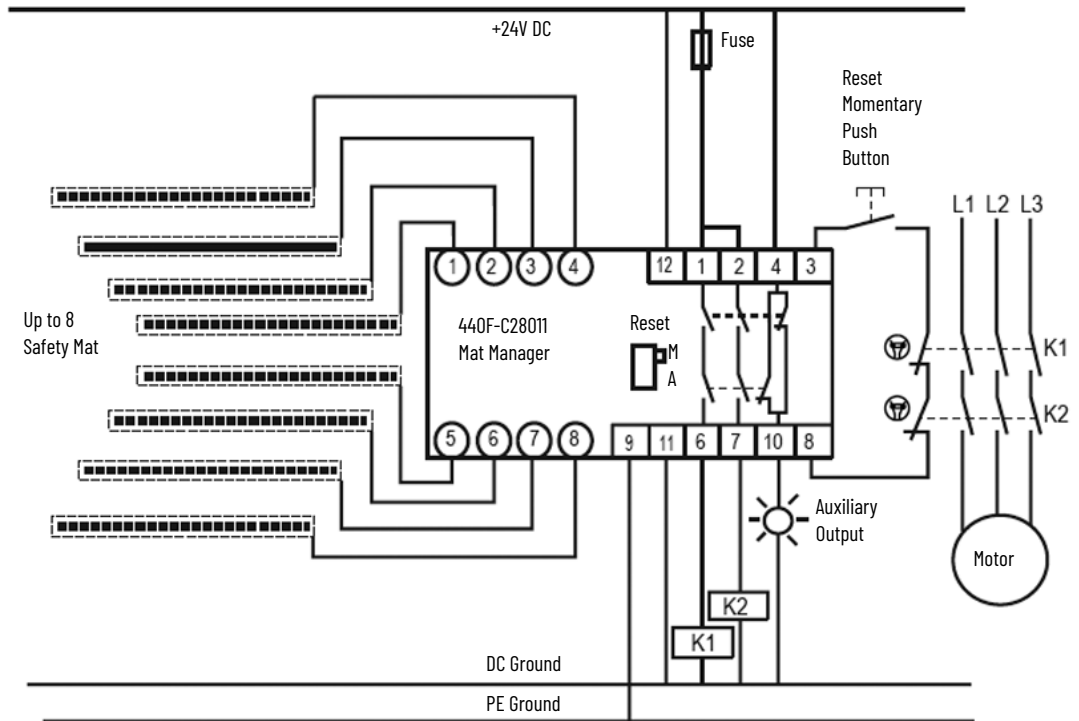

After completion of the design of the safety-related control system, confirm that the response time assumed in [Combined Trip and Presence Sensing System on page 20](#) remains valid. If the value changes, you must repeat the safety distance calculations.

Reset Modes

Two reset operating modes are configurable via a selection switch inside the mat manager:

- Manual Reset
- Auto Reset

The consequences of the selected reset scheme must be carefully considered for hazards that unexpected startups cause, both under normal conditions and under fault conditions. Timing diagrams are given in [Figure 15](#) and [Figure 16 on page 28](#) for both modes of the Guardmaster system.

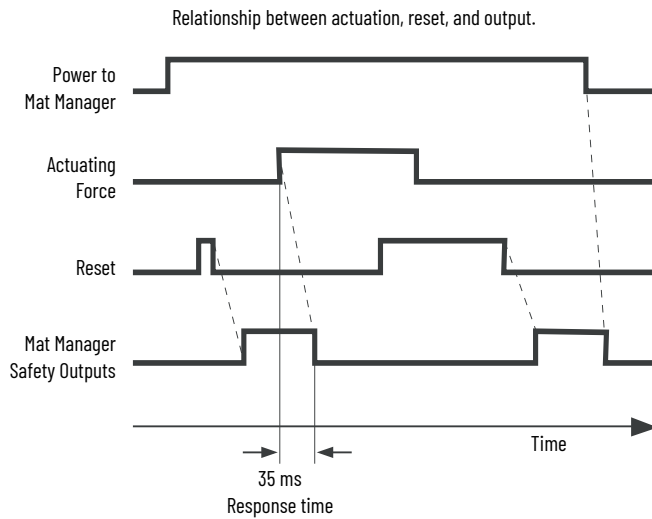
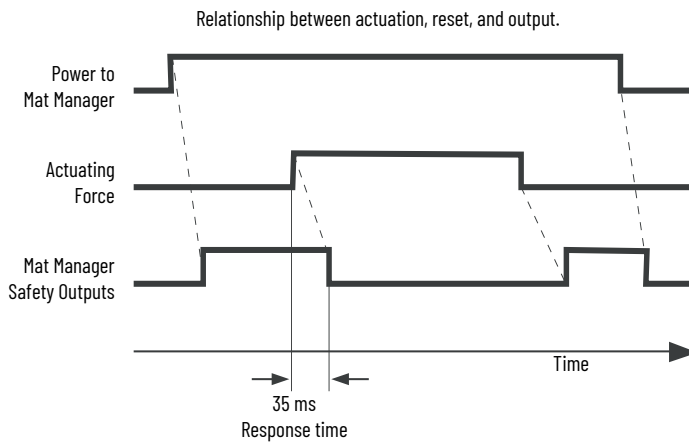
Figure 15 - Manual Reset Mode**Figure 16 - Auto Reset Mode**

Manual Reset Mode

In manual reset mode, the output-on signal can only be restored after the actuating force is removed and after a reset. To initiate manual reset, push and release a remotely mounted momentary Reset button, or use voltage-free contacts within the machine safety-related control system. At power-on or following the loss and subsequent restoration of power, the outputs are off until a reset signal is received even if the safety mat is not actuated. The safety outputs of the Guardmaster mat manager remain off until reset after power-up and can require primary/secondary reset circuits in complex systems where other power-up interlocks (start interlocks) are present.

Auto Reset Mode

In auto reset mode, the output-on signal is achieved solely by removal of the actuating force. For both modes, the safety contacts are always off (open) after the safety mat is actuated. When used in the auto reset mode, the control system of the machine requires a separate reset function to help prevent machine startup when stepping off the safety mat, or after a temporary power supply failure or dip.

Auxiliary Output

The auxiliary output is a non-safety output that is provided as a status output. The auxiliary output is useful in systems with a PLC functional machine control that are combined with hard-wired safety circuits as a status import to the PLC. Other uses include diagnostics in protection schemes, and/or drive status indicators or alarms. The safety function must not depend on this output.

Arc Suppression

Arc suppression networks or devices are recommended for all inductive loads. For safety circuits, suppressors must be fitted across the load and never across the contacts. The supply and load characteristics determine the type and ratings of the suppressors. Suppressors can increase response time, particularly suppressor diodes across DC coils, and must be in place when response times are measured.

Final Safety Mat Layout

After you have considered the previous factors, the safety mat layout can be checked and finalized. Consider whether the machine response time has changed from the initial calculations.

Whenever possible, arrange safety mats with the wires at the outside edge of the detection zone. This arrangement simplifies installation and replacement, if necessary, and all wiring is protected by the perimeter trim.

Wiring

All Guardmaster wiring must be protected from mechanical damage and suitably sealed for the operating environment. Waterproof butt connectors are supplied for mat-to-mat connections and are protected by the edge trim. Where wire runs are required across the floor, the 440F-A3230 wire guide can provide suitable protection. Conduit or cable troughs must be used for other wire runs. To maintain the sealing integrity of the mat manager, use the correctly sized and tightened conduit fittings or cable glands to IP65.

Wiring from the mat manager to the safety mat can be buried in the floor using conduit, or pass via the edge trim. Flexible conduit is recommended for this type of installation. See [Install and Commission on page 31](#) for further details. Determine the wiring method and determine the input and output connection points for the safety-mat-to-mat-manager wiring.

Final Details

Prepare a work schedule and drawings of the system layout and the electrical circuit. We recommend that you record and retain all measurements and calculations in the technical file for the machine.

Notes:

Install and Commission

-
- IMPORTANT**
- Read this manual in full before installation. Study this chapter completely before starting work.
 - Wiring must be in accordance with the National Electric Code and applicable local codes and ordinances.
-

The system designer must supervise the installation and commissioning. A mechanical technician and an electrician, familiar with industrial wiring practices, are required to install the system. A trained electrical technician that is experienced in safety installations must perform the commissioning.

The following special tools are required:

- Crimp tool for pre-insulated butt splice connectors (for example, Raychem AD-1522-T).
- Hot air gun with reflector attachment for heat shrinking (for example, Raychem HL1802E).

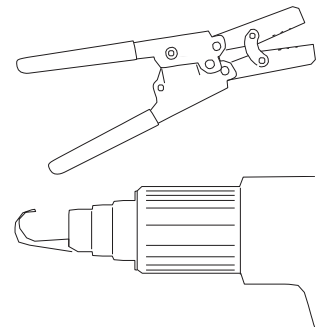

Safety Mat Installation

Isolate and lock off the machine power supply at the source.

1. Check that the floor is flat, smooth, clean, and free of debris and that buried conduit or other wiring provision is correctly in place.
2. Unpack the safety mats. Keep the safety mats flat and not to pull on the wires.
3. Place the safety mats on the floor in the planned positions with the connecting wires at the periphery of the detection zone as shown in [Figure 17 on page 32](#).
4. Depending on the number of individual safety mats needed to cover the protective area, connect the safety mat wiring in a series configuration, if necessary.

-
- IMPORTANT** Leave a sufficient wire tail length to enable reconnection if a safety mat must be replaced, but confirm that the interconnecting wires fit easily under the edge trim without being crushed.
-

5. Use the supplied butt connectors to join the wires, as shown in [Figure 19 on page 32](#). Where the safety mat wires require extensions (for example, front safety mat to rear safety mat connections, and mat manager connections), use an extra pair of the butt connectors and a length of twin wire.

Figure 17 - Typical Illustration of Safety Mat Cable Routing [mm (in.)]

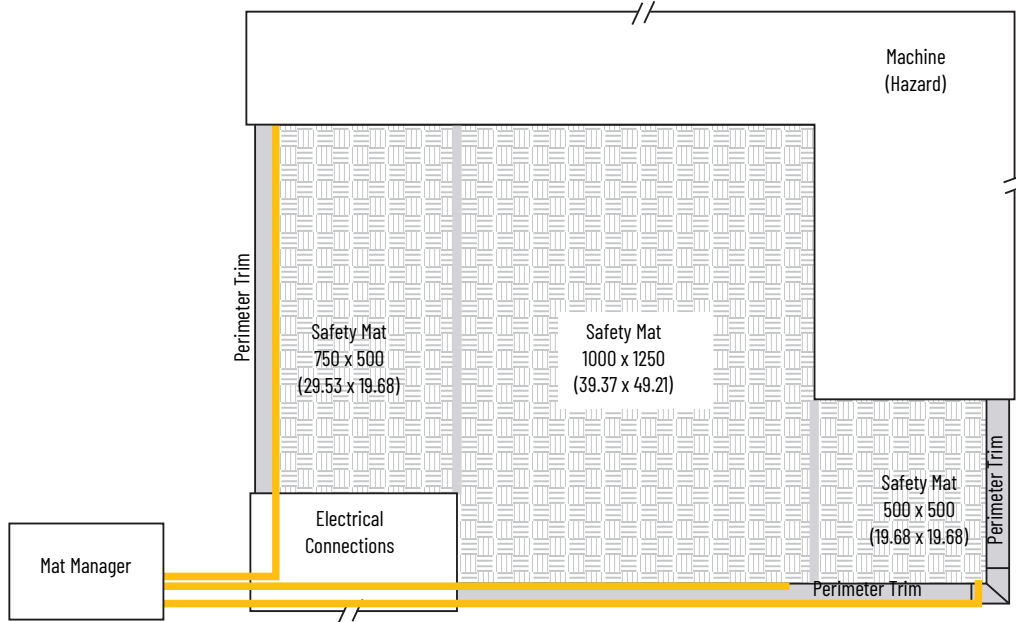
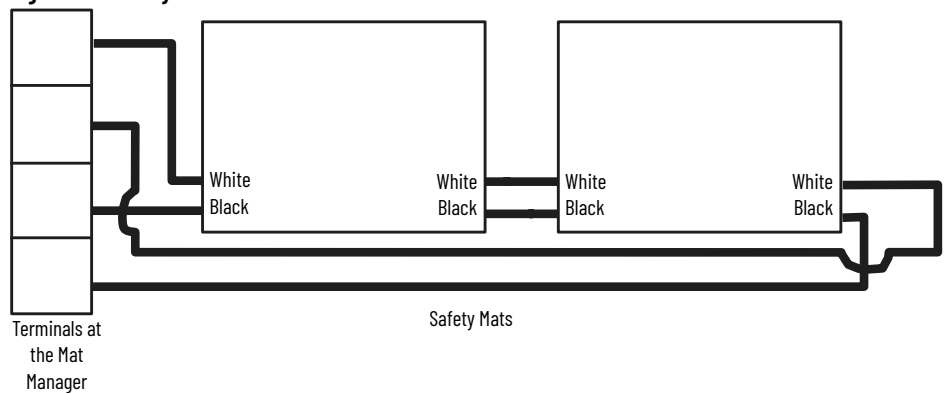
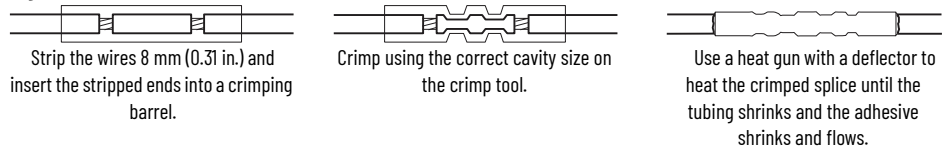

Figure 18 - Safety Mat Series Connections



The safety mat wires have a black outer covering; two have a black inner sheath and two have a white inner sheath (see [Figure 19](#)).

Figure 19 - Wire Connections



6. Install trims. Uniting trim is required between each adjacent safety mat to prevent any dead zones from occurring in your installation. Perimeter trim is also required to hold the safety mats in place. See [Safety Mat Dimensions on page 33](#), [Active Uniting Trim Fixing on page 34](#), and [Perimeter Trim Fixing on page 34](#).
7. Install the mat manager and mounting, connect individual safety mats, and interconnect to the machine safety circuit.

Safety Mat Dimensions

Use perimeter trim to secure safety mats in place during installation. Active uniting trim is required between safety mats when using multiple units to cover an area. Proper use of perimeter and/or active uniting trims must be considered when calculating the total area covered by safety mats. [Figure 20](#) shows the additional distances to add to the nominal safety mat sizes when calculating the total area. For example, a system with four 1500 x 1000 mm (59.1 x 39.4 in.) safety mats with 440F-T3x10 perimeter trim and active uniting trim occupies an area of 3114 x 2114 mm (122.6 x 83.2 in.).

Figure 20 - Perimeter Trim and Uniting Trim Showing Detection Zone

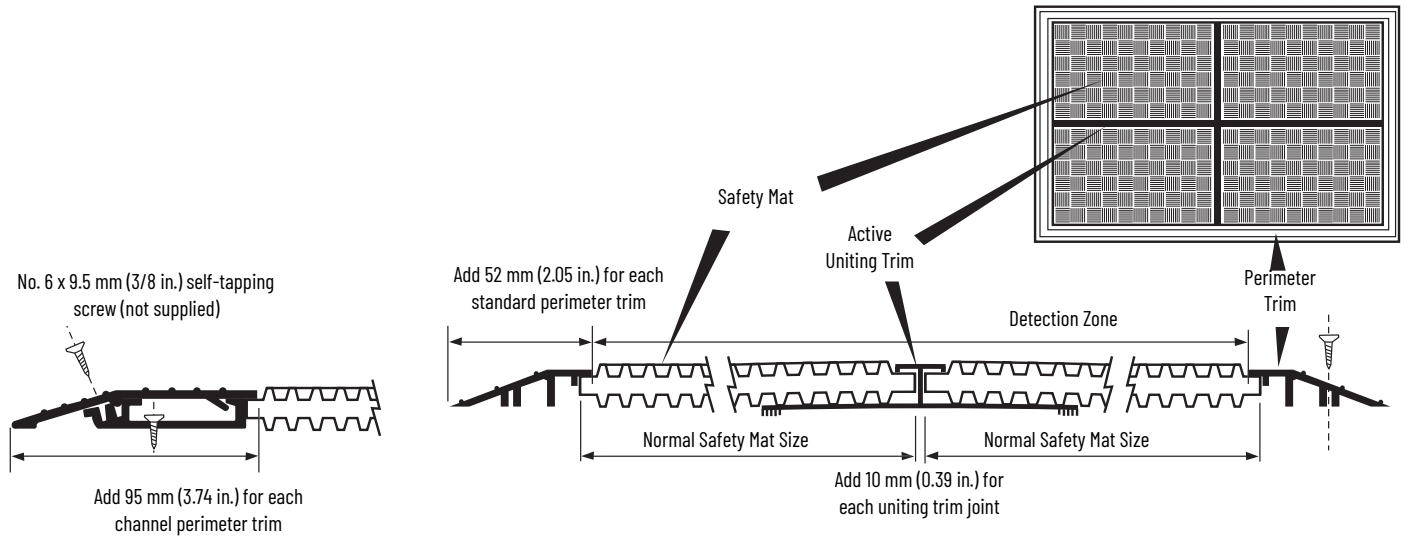

For applications where the safety mat is installed below floor level, an additional 6 mm (0.24 in.) must be added to the nominal dimension of each safety mat, as shown in [Figure 21](#).

Figure 21 - Below Floor Level Installation

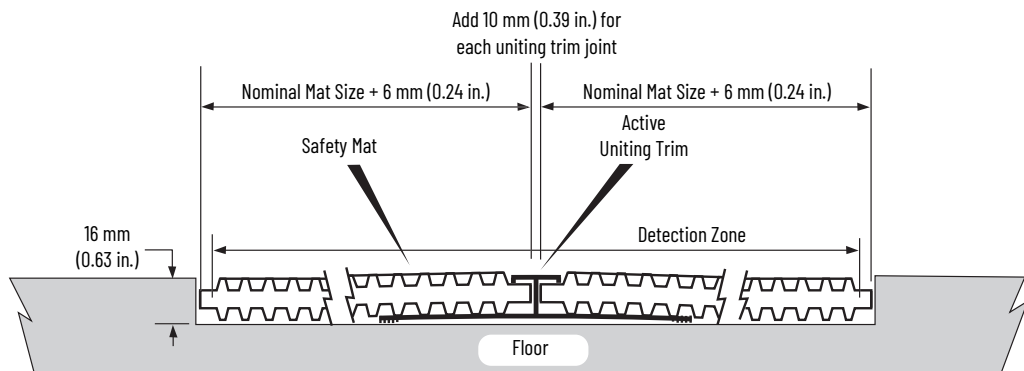

Active Uniting Trim Fixing

All active uniting trim sections that are used in installation must be blunt mitered to 45°, as shown in [Figure 22](#), to help with installation and to retain the overall sensitivity of the sensing area. [Figure 23](#) shows junctions of typical multiple safety mat configurations.

Figure 22 - 45° Miter

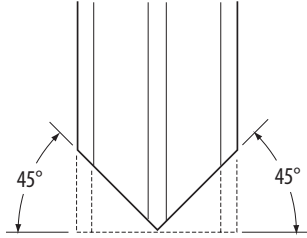
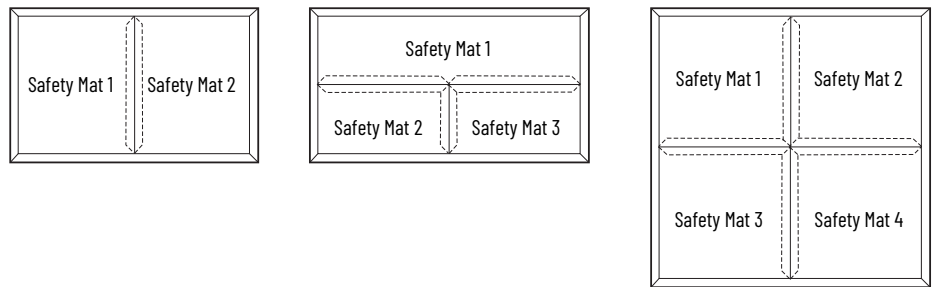

Figure 23 - Multiple Safety Mat Configurations



Perimeter Trim Fixing

Where the wiring to the mat manager is not buried, notch the perimeter trim at the wire entry and exit positions, and cut the trim slope to suit the conduit system. See [Figure 24 on page 35](#) for conduit system options. Notch the trim thoroughly so that the wiring is not trapped when the perimeter trim flexes. Verify that there are no sharp edges or burrs, which can damage the wires.

Figure 24 - Perimeter Trim Fixings

440F-T3210
440F-T3310
440F-T3510
Use edge grommets over sharp edges.

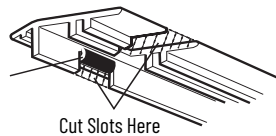

440F-T3210
440F-T3310
440F-T3510

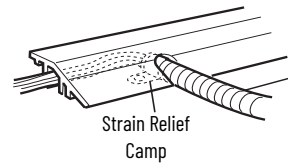

Use a strain relief clamp with flexible conduit.

440F-T3211
440F-T3411
Suggested cutout for flexible conduit entry.

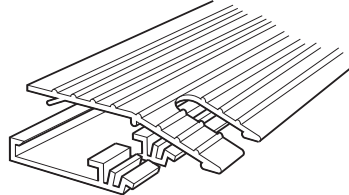

Suggested cut-out for safety mat wires that enter the cable trunk (base of perimeter trim).

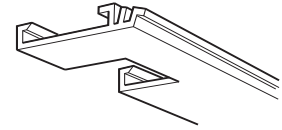

For external corner trim, use 440F-T3014. For internal corner trim, use 440F-T3015.

440F-T3012
Aluminum external corner perimeter trim. (Use with 440F-T3510, 440F-T3310, and 440F-T3210)

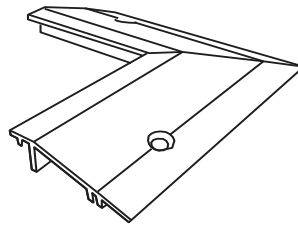

440F-T3013
Aluminum internal corner perimeter trim. (Use with 440F-T3510, 440F-T3310, and 440F-T3210)

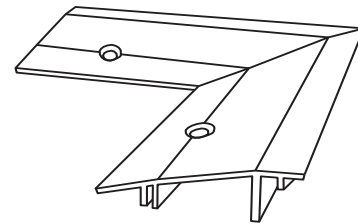

Mark out the edge trim fixing positions on the floor, allowing the trim to overlap the safety mat. Use the holes in the trim as a guide to mark out and drill the floor (fit plugs, if necessary). Clean off the floor and fix the safety mats and edge trim in place with countersunk screws to suit the application.

As you fix the perimeter trim, verify that none of the wiring is trapped or crushed between the trim and the floor or the top and bottom sections (depending on trim type). If it is possible to catch or pull the wires, you must use a strain relief clamp where the wiring exits the perimeter trim. All wiring must be protected in suitable conduit. If possible, the wiring or conduit must not cross a floor area where it is a tripping hazard. If crossing the floor cannot be avoided, the wiring/conduit must be enclosed within a protective wire guide (catalog number 440F-A3230).

Mat Manager Installation and Wiring



ATTENTION: Verify that the power supply remains isolated and locked off until [Electrical Functions Check on page 54](#).

The mat manager must be installed as supplied. The mat manager must not be modified or subjected to procedures or connections other than what is described in this publication.

Mount the mat manager in the planned position. All wiring to the mat manager includes:

- Individual safety mat connections.
- Power and I/O wiring (AC/DC voltage, inter-connection to wire safety outputs within the machine safety control circuit).

Mat Manager Enclosure Layout

See the following details to identify the location and types of required connection.

Figure 25 - Display Pane (front of enclosure)



Figure 26 - Product Label Location (side of the enclosure)



Figure 27 - Mounting Option

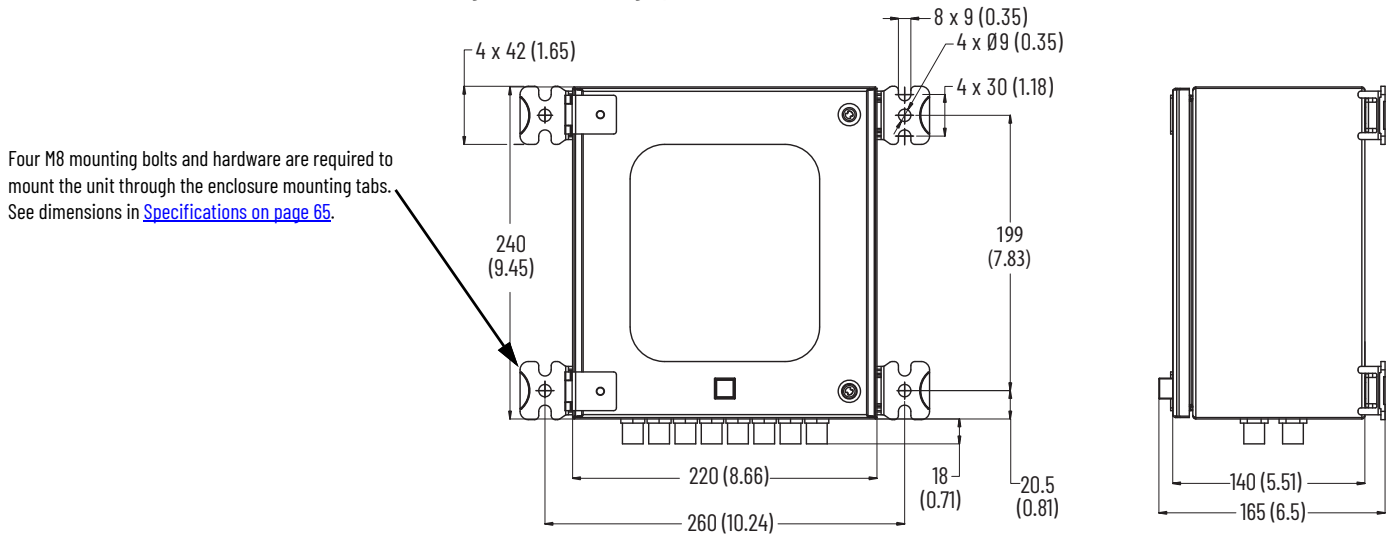

Figure 28 - Main Control Board, Safety Mat Connectors and DIP Switches (Inside Enclosure)

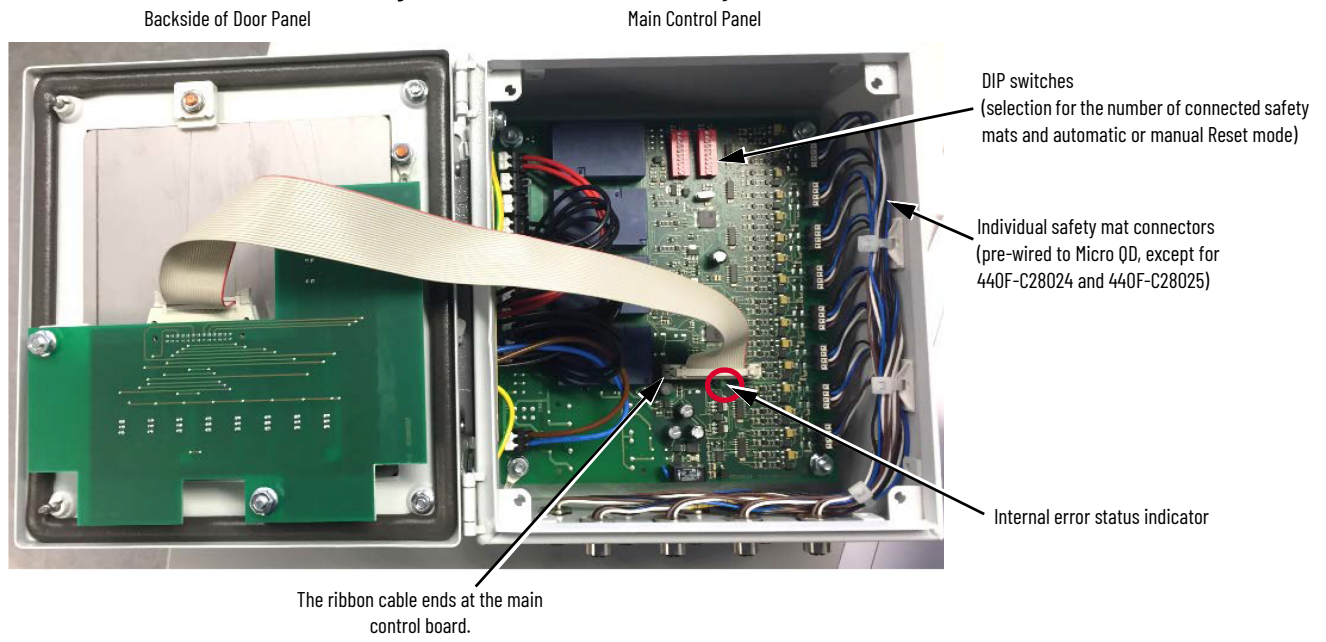
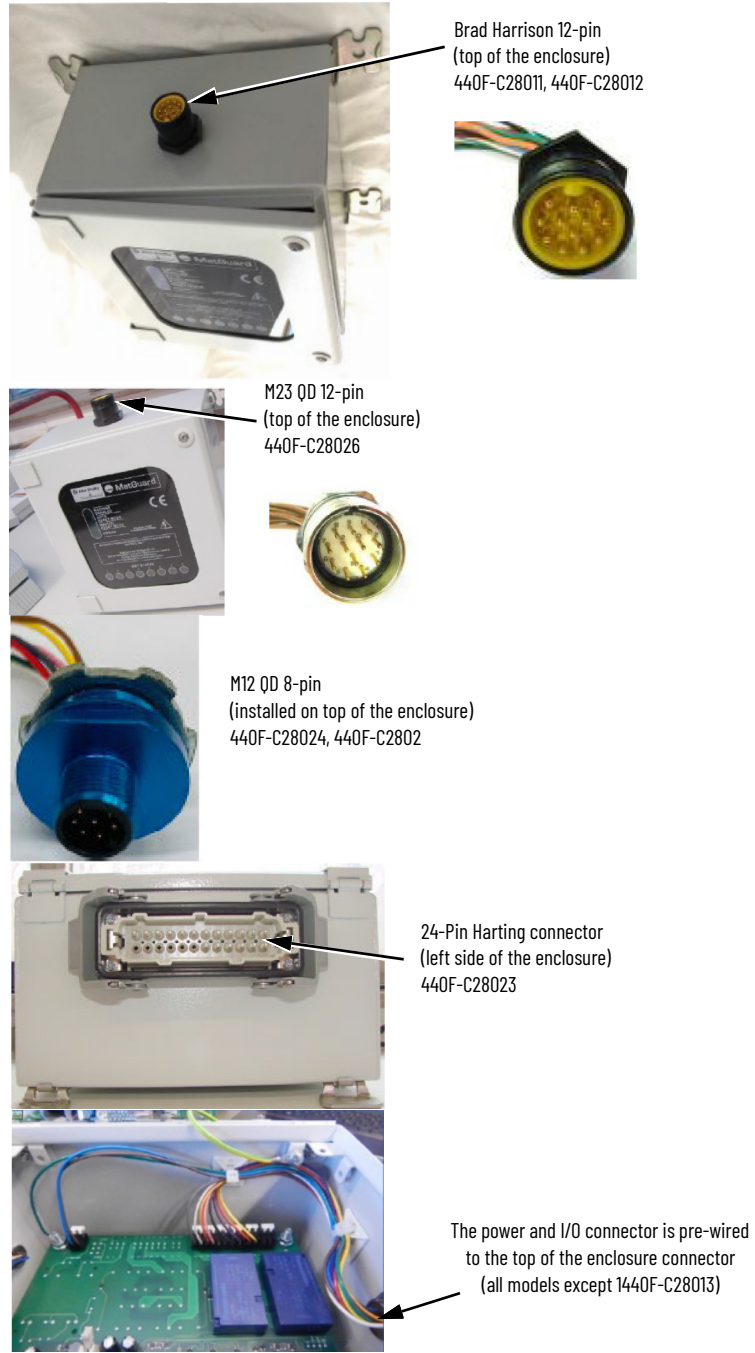

Figure 29 - Power and I/O Connectors per Model



All wiring to the mat manager routes through the connections on the enclosure. The configuration depends on the catalog number. See [Table 3 on page 39](#).

Table 3 - Wiring Specifications

Cat. No	Mat Manager Power Required ⁽¹⁾	Safety Mat Connection ⁽²⁾			Safety Outputs		Auxiliary Outputs		Output Current	Power and I/O Connection ⁽²⁾		Manual Reset Button ⁽²⁾
		Qty	Type	Location	Qty	Type	Qty	Type		Type	Location	
440F-C28011	24V DC	8	M12 Micro QD 4-pins	Bottom side of enclosure ⁽³⁾ Figure 30 on page 40	2	N.O.	1	N.C.	4 A	Brad Harrison 12-pin	Top side of enclosure Figure 29 on page 38	No
440F-C28012	115/230V AC	8	M12 Micro QD 4-pins	Bottom side of enclosure ⁽³⁾ Figure 30 on page 40	2	N.O.	1	N.C.	4 A	Brad Harrison 12-pin	Top side of enclosure Figure 29 on page 38	No
440F-C28013	24V DC, 115/230V AC	8	M12 Micro QD 4-pins	Bottom side of enclosure ⁽³⁾ Figure 30 on page 40	2	N.O.	1	N.C.	4 A	Terminal strip	No connector ⁽⁴⁾ Figure 28 on page 37	Yes
440F-C28023	115/230V AC	8	M12 Micro QD 4-pins	Bottom side of enclosure ⁽³⁾ Figure 30 on page 40	6	N.O.	1	N.O.	4 A	Harting 24-pin	Left (hinge) side of enclosure Figure 29 on page 38	No
440F-C28024	24V DC	8	Cord grips ⁽⁵⁾	Bottom side of enclosure Figure 34 on page 42	2	N.O.	1	N.C.	2 A	M12 QD 8-pin	Top side of enclosure Figure 29 on page 38	Yes
440F-C28025	24V DC	8	Cord grips ⁽⁵⁾	Bottom side of enclosure Figure 34 on page 42	2	N.O.	1	N.C.	2 A	M12 QD 8-pin	Top side of enclosure Figure 29 on page 38	No
440F-C28026	24V DC	8	M12 Micro QD 4-pins	Bottom side of enclosure ⁽³⁾ Figure 30 on page 40	2	N.O.	1	N.C.	-	M23 QD 12-pin	Top side of enclosure Figure 29 on page 38	No

(1) Supplied via the power and I/O connection.

(2) Mounted on the enclosure.

(3) Labeled 1...8

(4) Requires a hole punch for direct wiring to the control board connection.

(5) Accepts flying leads from the safety mat.

IMPORTANT AC supply must be externally fused at the point of supply by a 500 mA (maximum) high rupture capacity (HRC) fuse. Unless the neutral side of the supply is referenced to earth, neutral must be fused to the same specification.

Individual Safety Mat Connections

Up to eight safety mats can be connected to the mat manager. The connection type is 4-pin, single keyway, micro quick-disconnect (QD) connectors, or cord grip, depending on the model. [Figure 30 on page 40](#) shows how the individual safety mats are connected to the mat manager. If less than eight safety mats are connected, the other connections must be deactivated via the internal DIP switch selection. Open the cover to the mat manager and set the DIP switches as shown in [Figure 31 on page 40](#).

Figure 30 - Connections to Mat Manager

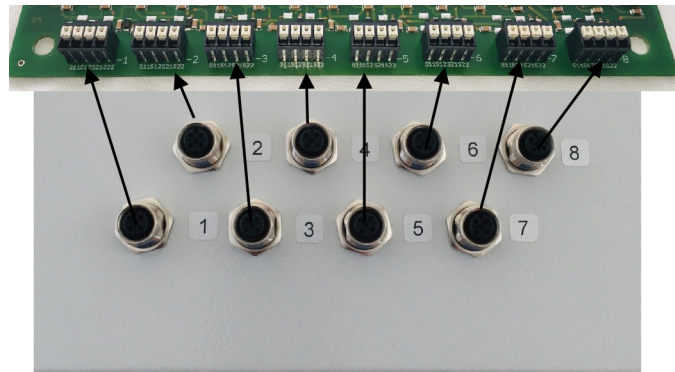
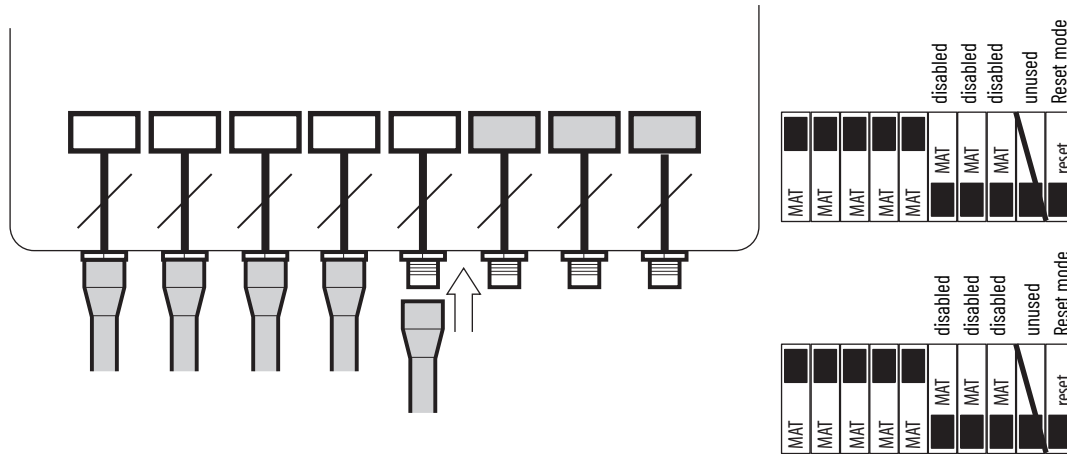

Figure 31 - Connections with DIP Switch Configuration



Safety Mat Selection

The number of connected safety mats can be selected with both internal DIP switches (see [Figure 32 on page 41](#)) on the main board. Factory setting is all safety mats enabled. Unused inputs must be deactivated as follows:

1. Remove the power supply from the mat manager.
2. Move switch 8 on both DIP switches from on to off to deactivate the last safety mat.
3. Repeat for the switches of the other safety mats to be deactivated, if necessary.
4. Apply changes to both rows of DIP switches to keep the system redundant.
5. When complete, apply power to the system. Modified settings are now active.

If there is a discrepancy, the system turns into the Internal Error status. See [Internal Error on page 62](#) for details and how to fix the problem.

Figure 32 - DIP Switches

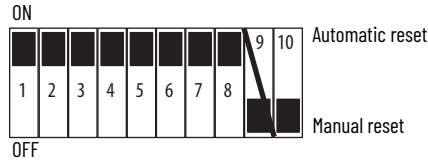
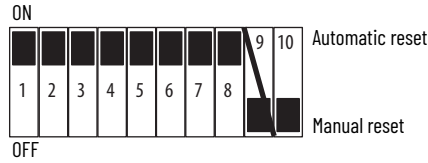

Safety Mat M12 QD Connections

[Figure 33](#) illustrates the pinout for each individual safety mat and the mating quick disconnect connector on the mat manager.

Figure 33 - M12 QD Connections

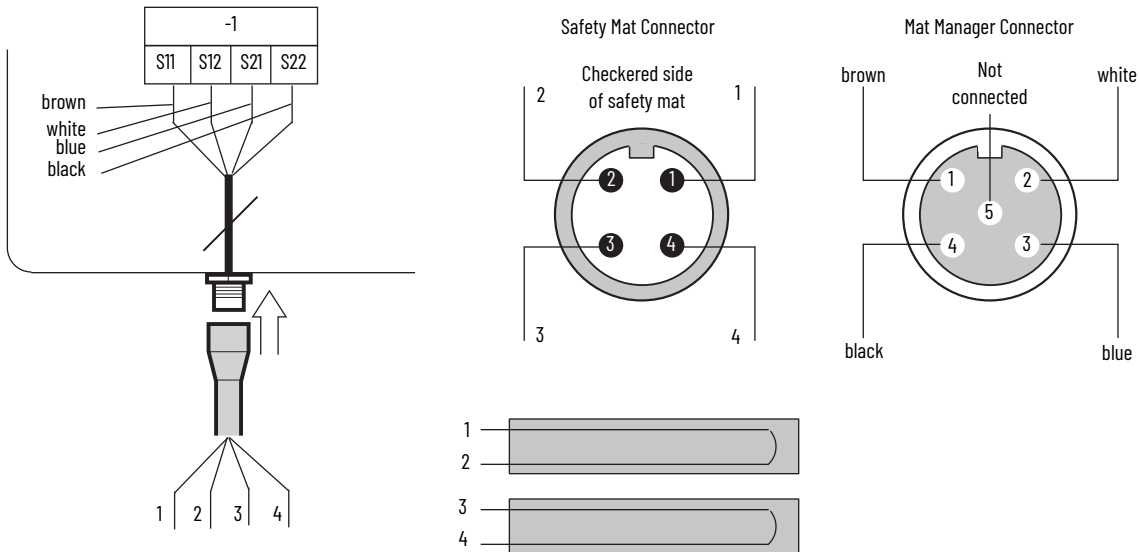

Flying Lead Connections

The 440F-C28024 and 440F-C28025 mat managers include cord grips for the direct wiring connection of flying leads, which are shown in [Figure 34](#).

Figure 34 - Cord Grips

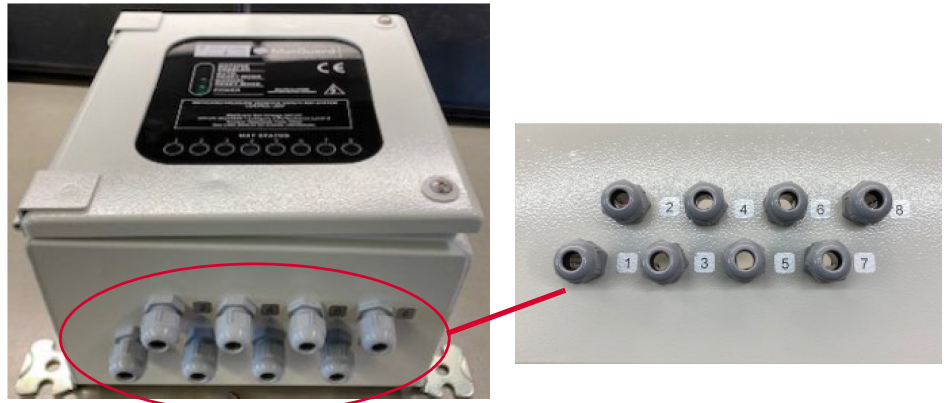
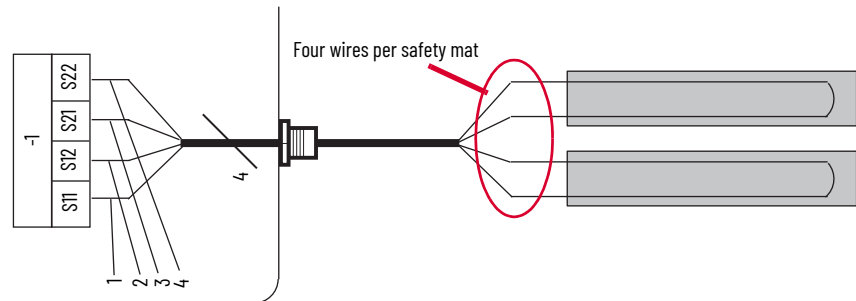

Figure 35 - Flying Lead Connection



The mat manager provides connections for eight individual safety mats. However, depending on the detection zone that is designed with standard safety mats, it can be necessary to connect multiple safety mats together. See the connection diagram in [Power and I/O Connector Diagrams on page 43](#).

Power and I/O Connector Diagrams

440F-C28011 and 440F-C28012 Mat Managers

Figure 36 - 12-pin Brad Harrison Connection

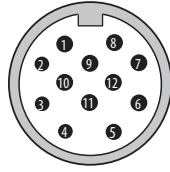

Table 4 - 440F-C28011 Mat Manager

Function	Pin	Wire Color	Controller Connection
Safety Output 1	1	Orange	53
	6	Orange w/ Black Trace	54
Safety Output 2	2	Blue	63
	7	Blue w/Black Trace	64
Auxiliary Output	4	Red w/ Black Trace	81
	10	Red	82
Monitoring Circuit	3	White w/ Black Trace	MCa
	8	Black w/ White Trace	MCb
Power	11	White	-ue
	12	Black	+ue
Ground	9	Green	GND/E

Table 5 - 440F-C28012 Mat Manager

Function	Pin	Wire Color	Controller Connection
Safety Output 1	1	Orange	53
	4	Red w/ Black Trace	54
Safety Output 2	7	Blue w/ Black Trace	63
	8	Black w/White Trace	64
Auxiliary Output	5	Green w/ Black Trace	81
	3	White w/ Black Trace	82
Reset/Monitoring Circuit	10	Red	MCb
Monitoring Circuit Input	2	Blue	MCa
Remote Reset Push Button	8	Orange w/Black Trace	PB
Power	11	White	Neutral
	12	Black	Line
Ground	9	Green	GND/E

IMPORTANT There is a new terminal connection on the safety outputs of 440F-C28012 mat managers.

See [Figure 29 on page 38](#). [Table 6](#) shows straight style mating cables for the 440F-C28011 and 440F-C28012 mat managers. Additional information and other mating cables can be found on our website (rockwellautomation.com/en-us/products/hardware/allen-bradley/connection-devices.html).

Table 6 - Mat Manager Mating Cables

Wire Color	Rating	Length [m (ft)]	Cat. No.
1 White 2 Green 3 Yellow 4 Gray 5 Rose 6 Red	7 Black 8 Violet 9 Green/Yellow 10 Orange 11 Blue 2 Brown	2 (6.5) 5 (16.4) 10 (32.8)	889N-F12AC-2 889N-F12AC-5 889N-F12AC-10

Interconnection to Machine Safety Circuit

Figure 37 shows an example connection diagram for the 440F-C28011 mat manager.

Example system operation:

- The supply of power is on; there is no presence on the safety mats, the normally open safety outputs are open and the loads are de-energized.
- The mat manager is configured for monitored manual reset.
- When you press and release the Reset button, the safety outputs on the mat manager close and the loads energize.
- When any of the safety mats are stepped on, the safety outputs open and power is removed from the loads.
- After you step off the safety mat, the Reset button must be pressed and released to reenergize the loads.

Figure 37 - Connection Diagram for 440F-C28011 Mat Manager

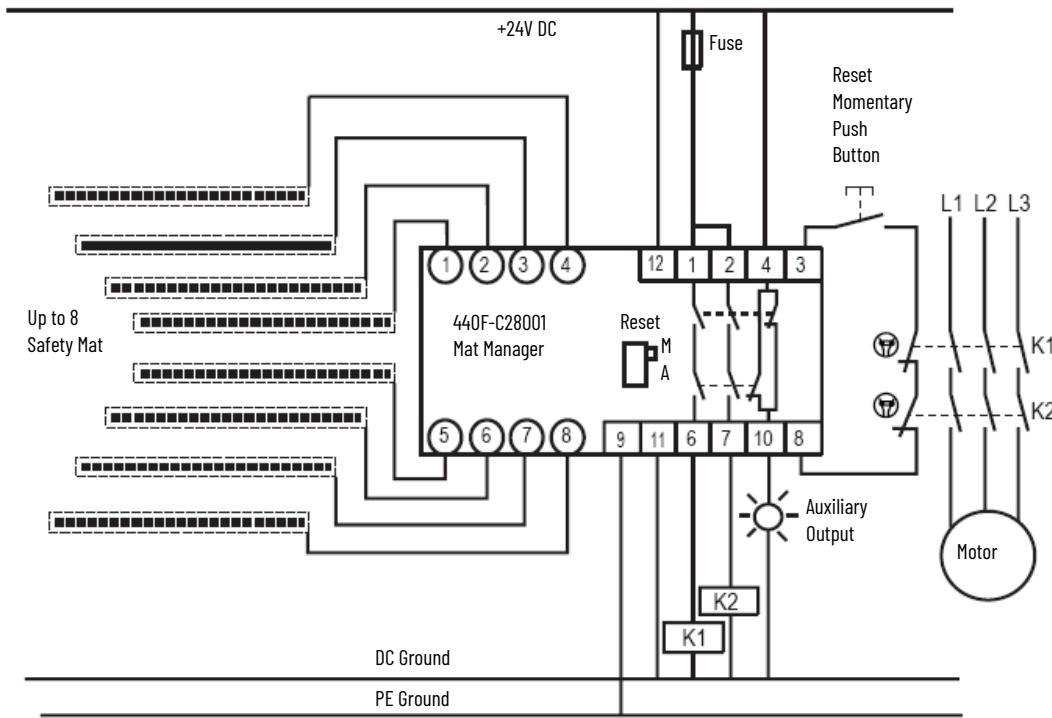
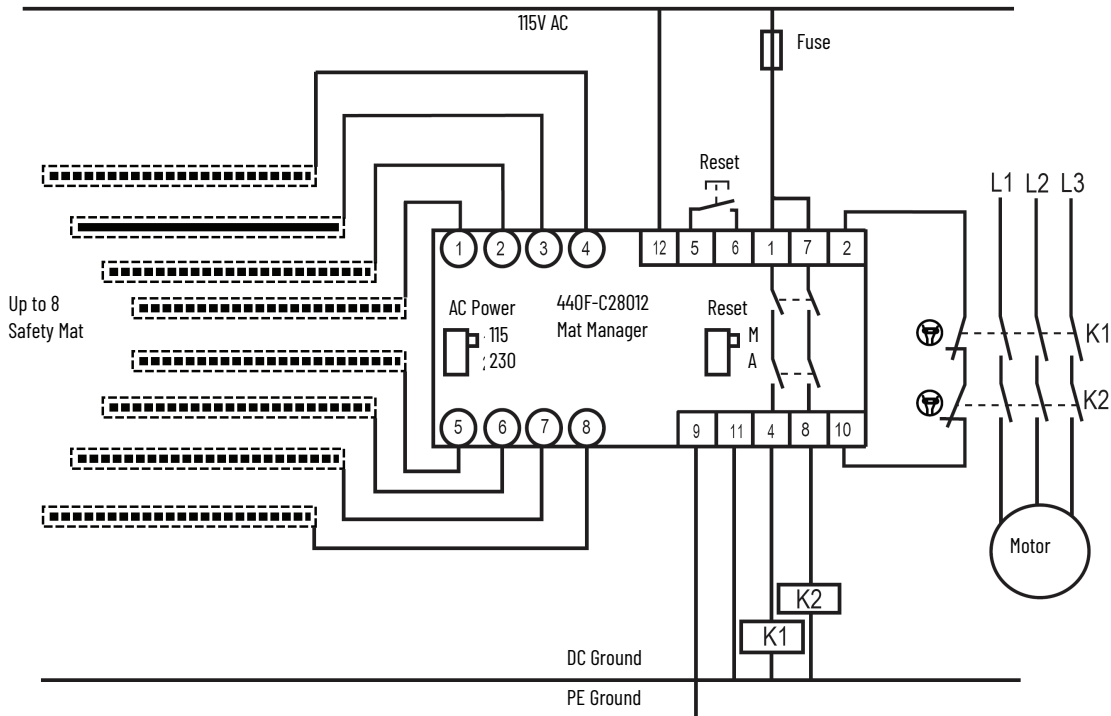

Figure 38 on page 45 shows an example connection diagram for the 440F-C28012 mat manager.

Example system operation:

- The supply of power is on; there is no presence on the safety mats, the normally open safety outputs are open and the loads are de-energized.
- There are new terminal connections on the safety contacts. The mat manager is configured for monitored manual reset.
- Press and release the Reset button to energize the loads.
- When any of the safety mats are stepped on, the safety outputs open and power is removed from the loads.
- After you step off the safety mat, the Reset button must be pressed and released to reenergize the loads.

Figure 38 - Connection Diagram for 440F-C28012 Mat Manager



440F-C28023 Mat Manager

Figure 39 - 24-Pin Harting Connector



See [Figure 29 on page 38](#). The Harting connector on the MatGuard™ Mat Manager consists of the following parts:

- Hood 09300240301
- Crimp terminal 09330242602
- Convex crimp contacts 09330006104

Contact Harting for an appropriate mating assembly.

Pin	440F-C28023
1	Line (L1) 115/230 V AC
2	Neutral (L2)
Case	Ground/E
3	Safety Output #1
4	Safety Output #1
5	Safety Output #2
6	Safety Output #2

Pin	440F-C28023
7	Safety Output #3
8	Safety Output #3
9	Safety Output #4
10	Safety Output #4
11	Safety Output #5
12	Safety Output #5
13	Safety Output #6
14	Safety Output #6
15	N.O. Aux Output #1
16	N.O. Aux Output #1
17	Reset Push Button
18	Reset Push Button
19	No Connection
20	No Connection
21	No Connection
22	No Connection
23	No Connection
24	No Connection

Interconnection to Machine Safety Circuit

[Figure 40 on page 47](#) shows an example connection diagram and 440F-C28023 mat managers.

Example system operation:

- The power supply is on; there is no presence on the safety mats, the normally open safety outputs are open and the loads are de-energized.
- The mat manager is configured for automatic reset.
- Press the Start button to energize the loads. If you step on any of the safety mats, the safety outputs open and power is removed from the loads.
- Contactor K1 drops out and opens the latching circuit.
- After you step off the safety mats, the Start button must be pressed to close the safety outputs and reenergize the loads.

Figure 41 - Connection Diagram for 440F-C28023 Mat Managers with Manual Reset

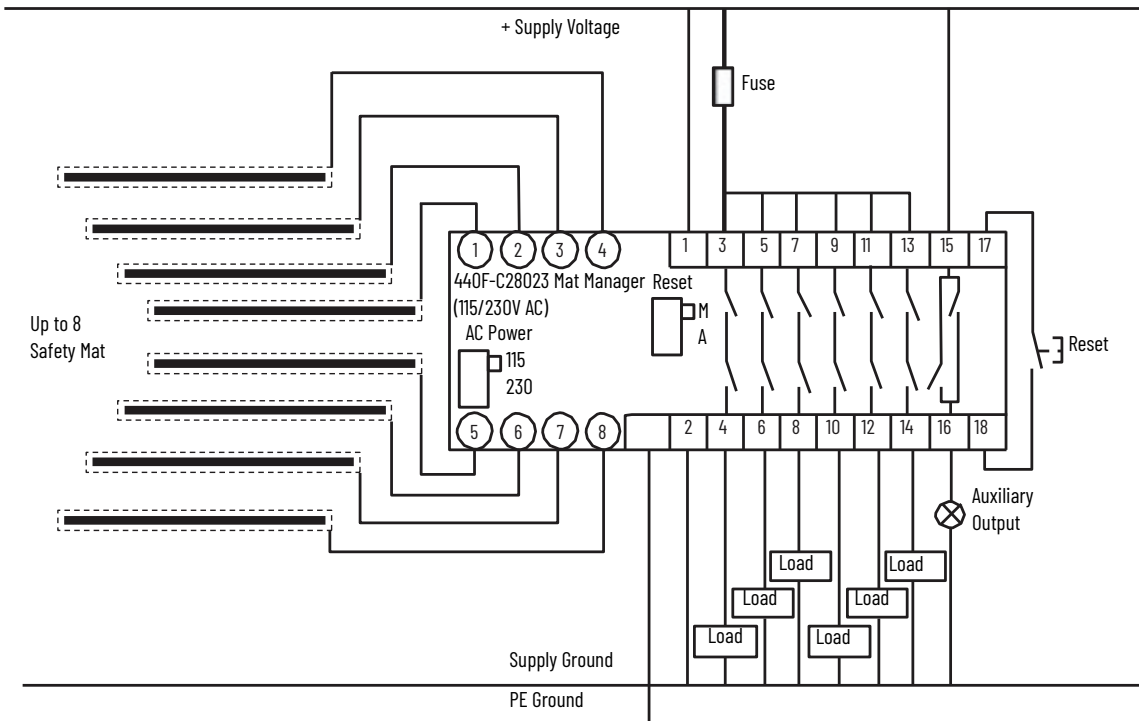

440F-C28024 and 440F-C28025 Mat Managers

Figure 42 - 8-pin Lumberg M12 Micro Connector (RSF-8-1/2-14/1F)

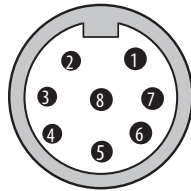

Table 7 - 440F-C28024 and 440F-C28025 Mat Managers

Function	Pin	Wire Color	Controller Connection
Safety Output 1	5	Gray	53
	1	White	54
Safety Output 2	6	Pink	63
	8	Red	64
Power	2	Brown	-ve
	7	Blue	+ve
Ground	3	Green	GND/E
No connection	4	Yellow	No Connection

Interconnection to Machine Safety Circuit

See [Figure 29 on page 38](#). [Figure 43](#) shows an example connection diagram for the 440F-C28024 mat manager.

Example system operation:

- The power supply is on; there is no presence on the safety mats, the normally open safety outputs are open and the loads are de-energized.
- The mat manager is configured for monitored manual reset.
- To energize the loads, press and release the Reset button on the front of the mat manager.
- When any of the safety mats are stepped on, the safety outputs open and power is removed from the loads.
- After you step off the safety mat, the Reset button must be pressed and released to reenergize the loads.

Figure 43 - Connection Diagram for 440F-C28024 Mat Manager

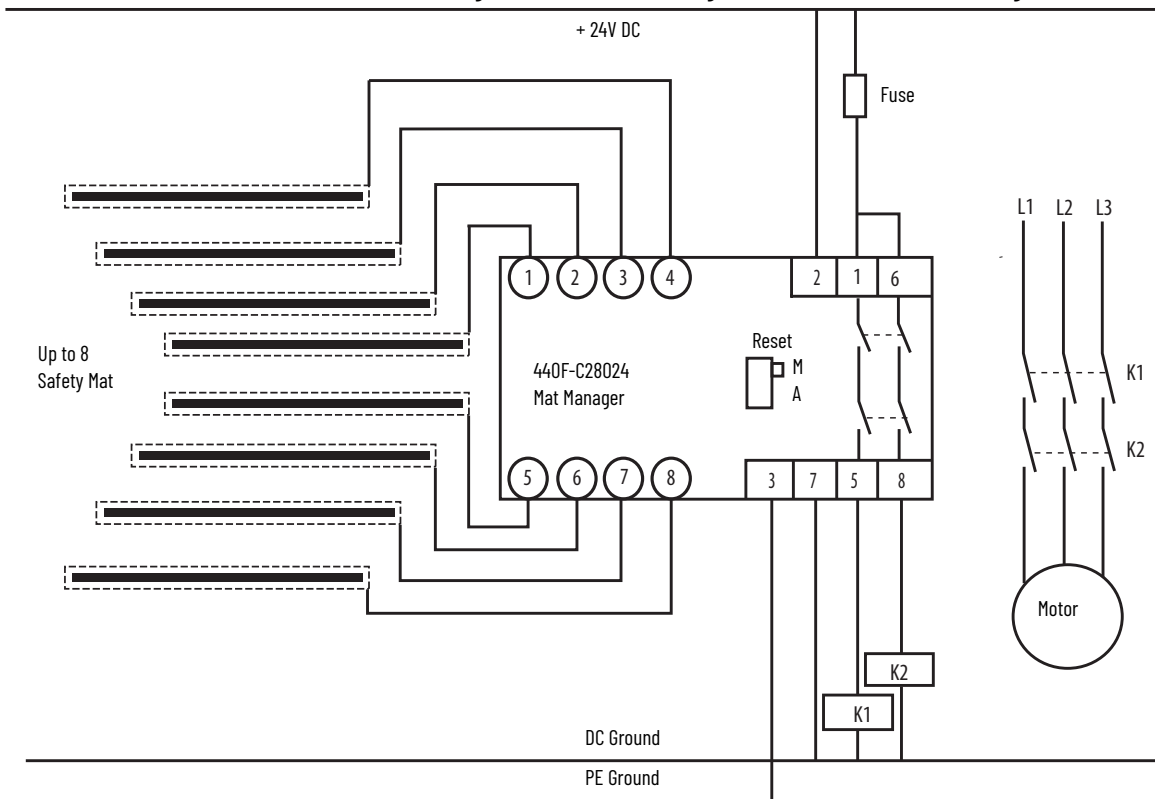

Interconnection to Machine Safety Circuit

[Figure 44 on page 50](#) shows an example connection diagram for the 440F-C28025 mat manager.

Example system operation:

- The power supply is on; there is no presence on the safety mats, the normally open safety outputs are open and the loads are de-energized.
- The mat manager is configured for automatic reset.
- Press and release the Start button to energize the loads.
- When any of the safety mats are stepped on, the safety outputs open and power is removed from the loads.

- After you step off the safety mat, the Reset button must be pressed and released to reenergize the loads.

Figure 44 - Connection Diagram for 440F-C28025 Mat Manager

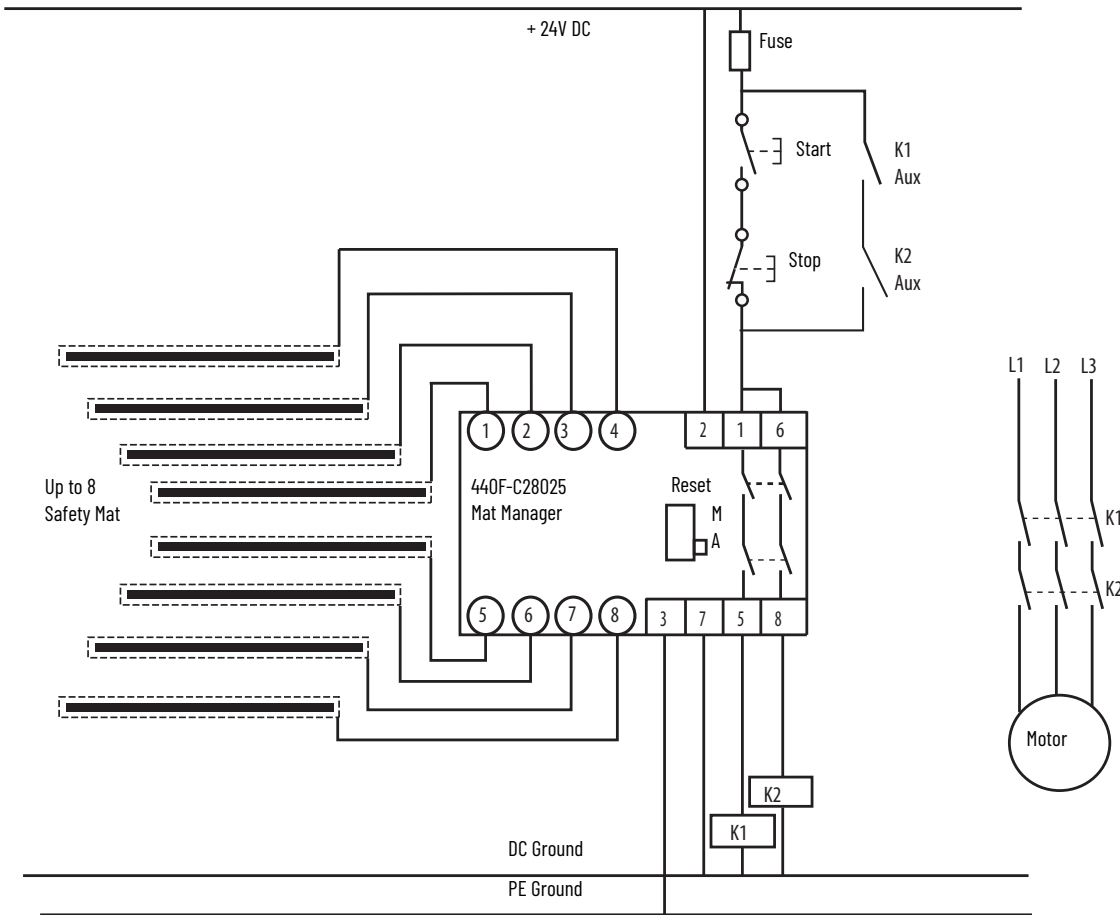

440F-C28026 Mat Manager

Figure 45 - 12-pin M23 Connection

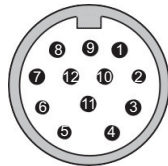

Table 8 - 440F-C28026 Mat Manager

Function	Pin	Wire Color	Controller Connection
Safety Output 1	7	White	53
	3	Gray	54
Safety Output 2	8	Red w/ Yellow Trace	63
	4	Pink	64
Auxiliary Output	9	Black	81
	10	Purple	82
Monitoring circuit	5	Red	MCa
	6	Yellow	MCb
Power	2	Blue	-ue
	1	Brown	+ue
Ground	12	Green	GND/E

See [Figure 29 on page 38](#). [Table 9](#) shows straight style mating cables for the 440F-C28026 mat manager. Additional information and other mating cables can be found on our website (rockwellautomation.com/en-us/products/hardware/allen-bradley/connection-devices.html).

Table 9 - Mat Manager Mating Cables

Wire Color		Rating	Length [m (ft)]	Cat. No.
1 Brown	7 White	18 AWG 300V 4 A	2 (6.5)	889M-F12AH2
2 Blue	8 Red/Blue		5 (16.4)	889M-F12AH-5
3 Gray	9 Black		10 (32.8)	889M-F12AH-10
4 Pink	10 Violet			
5 Red	1 Gray/Pink			
6 Yellow	12 Green			

Interconnection to Machine Safety Circuit

[Figure 46](#) shows an example connection diagram for the 440F-C28026 mat manager.

Example system operation:

- The supply of power is on; there is no presence on the safety mats, the normally open safety outputs are open and the loads are de-energized.
- The mat manager is configured for monitored manual reset.
- Press and release the Reset button to energize the loads.
- When any of the safety mats are stepped on, the safety outputs open and power is removed from the loads.
- After you step off the safety mat, the Reset button must be pressed and released to reenergize the loads.

Figure 46 - Connection Diagram for 440F-C28026 Mat Manager

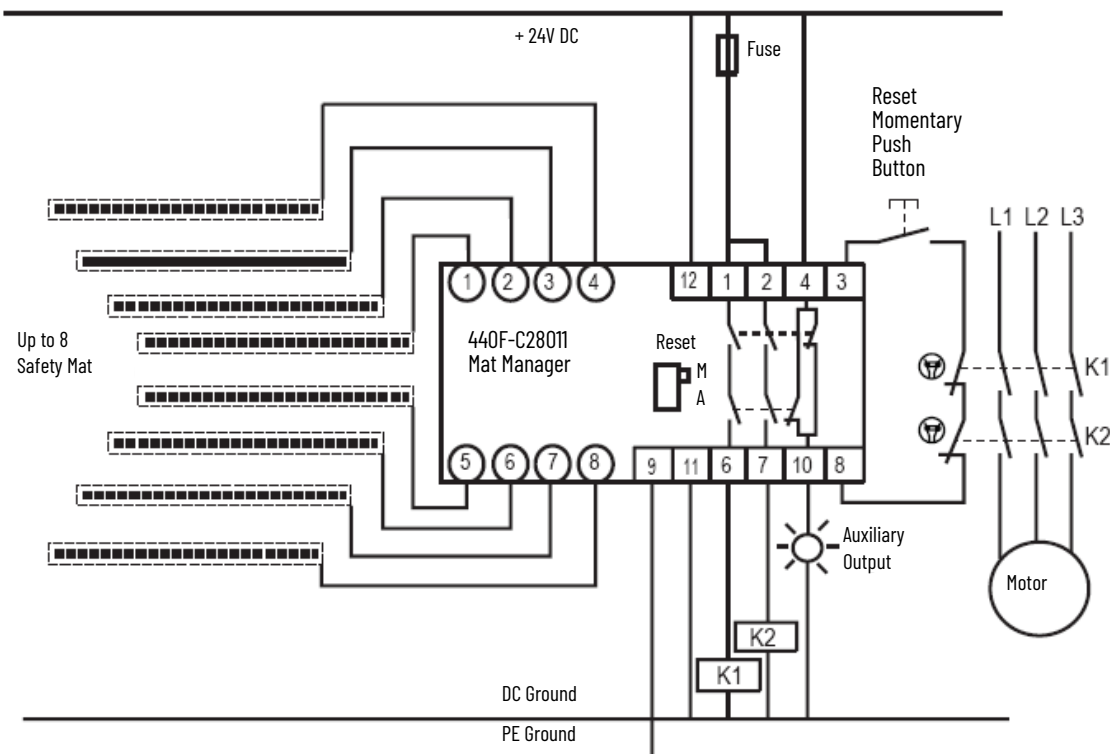

440F-C28013 Mat Manager

Figure 47 - Main Circuit Board of the Matguard Mat Manager

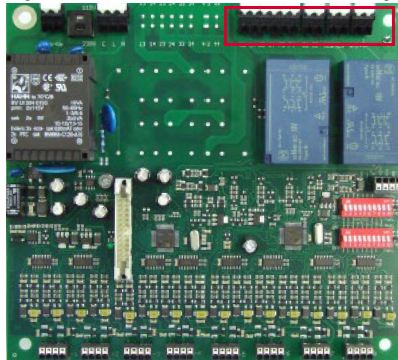

Table 10 - 440F-C28013 Mat Manager

Function	Terminal Number
Safety Output 1	53
	54
Safety Output 2	63
	64
Auxiliary Output	81
	82
Monitoring Circuit	MCa
	MCb
Power	-ue
	+ue
Ground	GND/E

Interconnection to Machine Safety Circuit

[Figure 48 on page 53](#) shows an example connection diagram for the 440F-C28013 mat manager.

Example system operation:

- The supply of power is on; there is no presence on the safety mats, the normally open safety outputs are open and the loads are de-energized.
- The mat manager is configured for monitored manual reset.
- Press and release the Reset button to energize the loads.
- When any of the safety mats are stepped on, the safety outputs open and power is removed from the loads.
- After you step off the safety mat, the Reset button must be pressed and released to reenergize the loads.

Figure 48 - Connection Diagram for 440F-C28013 Mat Manager

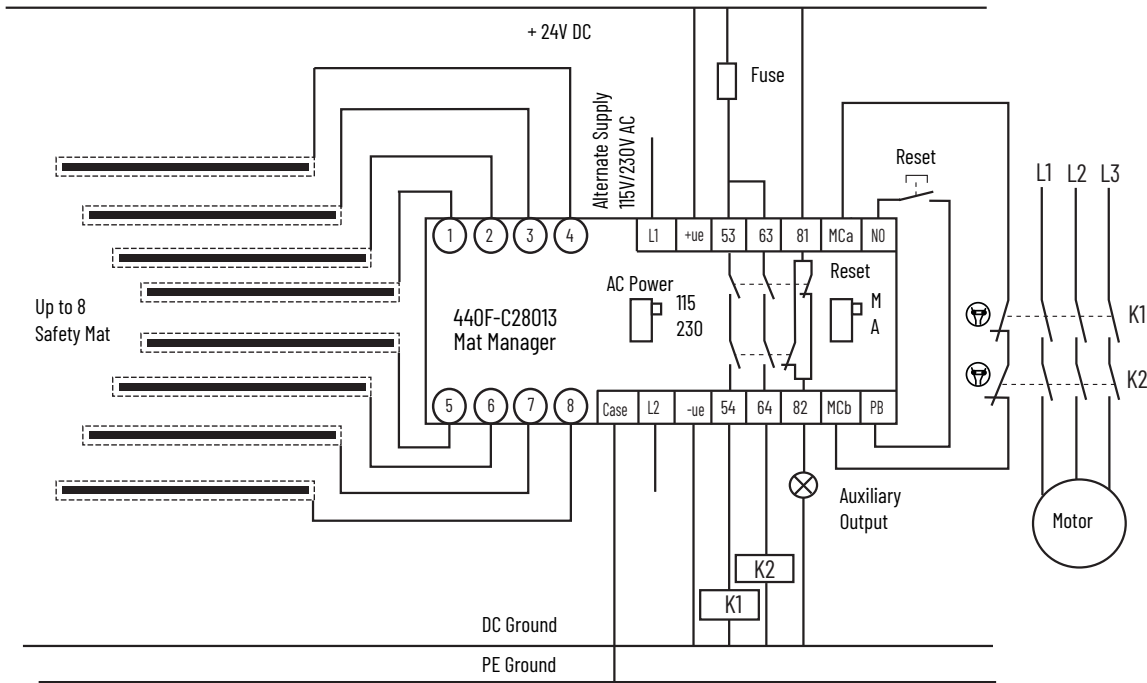

Reset Mode Selection

Two operating modes are available:

- Manual Reset
- Auto Reset

The operating mode is set with DIP switches on the main control board. See [Table 32 on page 41](#).

In Manual Reset mode, the output 'on' signal can only be restored after the actuating force is removed and after a reset. To achieve manual reset, push and release the lid-mounted mat manager reset button or a remote-mounted button. At power-on or following the loss and subsequent restoration of power, the outputs are off until a reset signal is received, even if the safety mat is not actuated.

In Auto Reset mode, only removal of the actuating force can restore the output-on signal. For both reset modes, the safety contacts are always off (open) after the safety mat is actuated.

Mode selection is covered in more detail in [Electrical Functions Check on page 54](#).

Check Mechanical Installation

1. Check that the Guardmaster® safety mats, perimeter trim, and uniting trims are undamaged and correctly positioned and secured.
2. Check that the designed safety distance is achieved.
3. Check that access to the hazardous zone is not possible, other than via the safety mat, and that fixed guards are positioned according to the design and are secure.
4. Check that the presence of a person between the hazardous zone and the safety mat is prevented.

5. Check that the environmental conditions, present or foreseeable, correspond to conditions considered during the design stage.
6. Check that the installation is free of hazards that were not foreseen at the design stage.
7. Check that warning notices are in place.
8. Check that any other required protective measures are installed.

Electrical Functions Check

The tasks that are necessary to complete this check differ, based on the Reset mode.

Manual Reset Mode Only

1. Verify that the safety mat is clear of persons and equipment. Temporarily disconnect any automatic reset function provided by the machine control system. Reinstall the machine power supply, but verify that the machine prime mover is still disconnected from the machine final contactors.
2. Check the mat manager for the following:
 - Power status indicator is illuminated (green)
 - Manual Reset mode status indicator is illuminated (green)
 - The Machine Enabled status indicator is off.
 - Safety Mat status indicators are either green (safety mat is connected) or off (no safety mat is connected, disabled via DIP switches).
3. Press and release the Reset button. Check for the following:
 - The Machine Enabled status indicator is illuminated.
4. Stand on a safety mat and check for the following:
 - The Machine Enabled status indicator turns off.
 - The appropriate safety mat status indicator turns red.
5. Step off the safety mat and check for the following:
 - The Machine Enabled status indicator remains off.
 - The appropriate safety mat status indicator turns green.
6. Press and release the Reset button, check for the following:
 - The Machine Enabled status indicator is illuminated.
7. To check the operation of each individual safety mat, repeat the previous tests.
8. To check the correct operation of any status monitoring that is connected to the Guardmaster system, repeat the previous steps.

Auto Reset Model Only

1. Verify that the safety mat is clear of persons and equipment. Temporarily disconnect any automatic reset function provided by the machine control system. Reinstall the machine power supply, but verify that the machine prime mover is still disconnected from the final contactors of the machine.
2. Check the mat manager for the following:
 - Power status indicator is illuminated (green)
 - Auto Reset mode is illuminated (green)
 - Machine Enabled status indicator is illuminated (green)

- Safety Mat status indicators are either green (safety mat is connected) or off (no safety mat is connected, input is disabled).
3. Stand on the safety mat and check for the following:
 - The Machine Enabled status indicator turns off.
 - The appropriate safety mat status indicator turns red.
 4. Step off the safety mat, check for the following:
 - The Machine Enabled status indicator is illuminated.
 - The appropriate safety mat status indicator turns green.
 5. To check the operation of each individual safety mat, repeat the previous tests.
 6. To check the correct operation of any status monitoring that is connected to the Guardmaster system, repeat the previous steps.

Functional Checkout

Reinstate the machine electrical supply. Check for the following:

1. Machine operation cannot commence until the Guardmaster mat manager is reset. Perform the walking test described in [Routine Inspection and Test on page 57](#).
2. Check that actuation of the safety mat stops hazardous movement.
3. Check that if you step off the safety mat, it does not start machine operation but does enable restart.
4. Check that when you approach the machine at a walking pace, hazardous movement stops before the hazardous zone can be reached. In critical applications, stop-time tests must be conducted.
5. If any type of muting system is installed, check that the Guardmaster system is muted only during non-hazardous parts of the operating cycle and that any mute indicators operate correctly.
6. Test the E-stop function of the machine.

IMPORTANT Verify that the personnel understand that no additional coverings, boards, plates, or planks are to be on the Guardmaster safety mat during operation of the machine.

Before putting the machine into its normal service, verify that operators and supervisors are aware of the nature and purpose of the Guardmaster system and that they understand the functions of the controls and indicators. Verify that the technical specifications, together with inspection, test, and service instructions, are available to the appropriate personnel and that an inspection record system is in place.

Notes:

Maintenance

Read this chapter in full before any maintenance is attempted. Attention is drawn to requirements for planned preventive maintenance. During maintenance operations, disconnect the prime mover of the machine before working on the Guardmaster® system. Observe electrical safety precautions.

Safety Mat Cleaning

IMPORTANT Do not use solvents to clean the safety mats.

The safety mats must be regularly swept to help prevent potential hazards. If you must wash or hose down the safety mats to clean or remove grease, you can use warm water and detergent.

Routine Inspection and Test

We recommend that you conduct weekly routine inspections and tests.

IMPORTANT The test interval depends on the use of the pressure-sensitive safety mat or pressure-sensitive floor and must be specified by the operator, according to the national legislative requirements.

1. Stop the machine.
2. Clean the safety mats and allow them to dry. Inspect the top surface of the safety mat for damage. Minor nicks and abrasions of the vinyl cover are acceptable, but any damage that exposes the metal plate must be dealt with immediately.
3. Check that the perimeter trim and uniting trim are not cracked, broken, or distorted and that the fixings are secure. Damaged parts must be replaced immediately.
4. Test the safety mat operation. Two persons are required, one to walk on the safety mat, the other to observe the mat manager. On systems that use Manual Reset mode, the Reset button must be continuously pressed and released.
 - a. Check that the Machine Enabled status indicator is on before actuation of the safety mat, and goes off as soon as the safety mat is stepped on.
 - b. Walk over each section of the safety mat and each joining section in turn (stand with both feet on the same uniting trim between two sections). The Machine Enabled status indicator must remain off during the entire time.
 - c. Step off the safety mat, operate the Reset button. Check that the Machine Enabled status indicator is illuminated.
 - d. Start the machine, step onto the safety mat and check that the machine stops immediately.
5. Check that all fixed guards, angle plates, and so on, are in place, undamaged, and securely fixed.

IMPORTANT If the inspection/test reveals any problems, do not allow use of the machine until they are resolved. Record the inspection and test in a written log.

Thorough Inspection and Test

We recommend twice yearly inspections or after damage.

Contact your local Allen-Bradley distributor or Rockwell Automation sales office for information on an authorized testing service. A person who is competent in electrical and mechanical engineering must perform the tests. Two persons are required, one to walk on the safety mat, the other to observe the mat manager.

1. Conduct the test in [Routine Inspection and Test on page 57](#).
2. Isolate the power source to the machine and Guardmaster system. Observe electrical safety precautions.
3. Inspect the safety mat components thoroughly for mechanical damage.
4. Disconnect the quick disconnect connectors of the safety mat from the mat manager.
5. Connect the two white wires to one test input of an ohmmeter and connect the two black wires to the other input. One person walks over each section of the safety mat in turn and each joining section in turn (stand with both feet on the same uniting trim between two sections) until all areas of the safety mat are covered. The maximum resistance with presence on the safety mat must not exceed 100 ohms.

IMPORTANT If the inspection/test reveals any problems, do not allow use of the machine until they are resolved. Record the inspection and test in a written log.

Check that the stopping performance of the machine has not deteriorated from the original safety distance calculations (see [Proper Positioning of Safety Mats on page 20](#)). Record the inspection and test in a written log.

Dismantle and Dispose



ATTENTION: Verify that the machine and Guardmaster system power is isolated and locked off at source before starting work.

To dismantle the safety mat system, the procedure is the reverse of the installation, with no extra hazards.

Confirm that the machine and safety mat system power is isolated and locked off at the source before starting work.

If the system is to be reconfigured or relocated, observe the handling precautions that are given in [Handling and Transport on page 9](#). The safety mat does not contain any hazardous materials that require special precautions for disposal.

Status Indicators and Troubleshooting

Disconnect the prime mover before working on the Guardmaster® control system with power applied. Observe electrical safety precautions.

Status Indicators

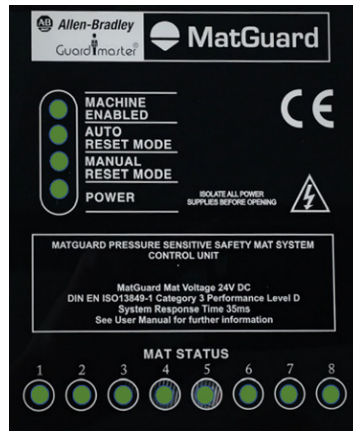

Label	Description	Status Indicator
Machine Enabled	System is ready, no faults	Green
Auto Reset Mode	In Auto Reset mode, the output 'on' signal is achieved solely by the removal of the actuating force. Safety contacts are off (open) after the safety mat is actuated. The control system of the machine requires a separate reset function to help prevent machine startup when stepping off the safety mat, or after a temporary power supply failure or dip.	Indicates which mode is selected
Manual Reset Mode	In Manual Reset mode, the output 'on' signal can only be restored after the actuating force is removed and after a reset. The manual reset is achieved by pushing and releasing a remotely mounted momentary Reset button or by voltage-free contacts within the machine safety-related control system. At power-on or following the loss and subsequent restoration of power, the outputs are off until a reset signal is received, even if the safety mat is not actuated. The safety outputs of the Guardmaster mat manager remain off until reset after power-up, and can require primary/secondary reset circuits in complex systems where other power-up interlocks (start interlocks) are present.	Indicates which mode is selected
Power	Active when AC/DC power is applied to the mat manager	Green
Mat Status 1...8	Green: Run condition, nothing present on safety mat Red: Stop condition, safety mat actuated Off: Safety mat input is not used and is disabled via switches (off)	Green/Red/Off

Internal Error

A flashing status indicator (inside the unit on the main board, beside the 26-pin flat cable connector) indicates an internal error. See [Figure 28 on page 37](#).

If there is an occurring internal error, all relays de-energize and the unit cannot be activated again. In this case, remove the unit from the power supply, try to resolve the fault, and power the unit up again. The following incidents can cause a recoverable internal error.

Problem	Solutions
The number of connected safety mats is higher than the DIP switch selection (for example: DIP switch 1 is on, switches 2...8 are off, but two safety mats are connected).	Check if the number of connected safety mats is equal to the DIP switch settings.
Internal error (flashing status indicator)	<ul style="list-style-type: none"> Settings of DIP switch 1 can differ from DIP switch 2. Confirm that both DIP switches have equal settings. Changes on the DIP switches must not be made while the unit is operating. Any changes must be done while the unit is powered off. Remove the unit from the power supply and power up again.
The Manual Reset button does not work	A permanent link between terminals PB and N.O. is set, even though the DIP switch selects Manual Reset mode. Replace the permanent link by a push button (N.O.).

Faults

Disconnect the prime mover before working on the safety mat control system with power applied. Observe electrical safety precautions.

No Start

The machine cannot be started with no presence on the safety mat and after the correct reset procedure was followed.

Resolution

1. If the Machine Enabled status indicator on the Guardmaster mat manager is on, there is a probable fault on the machine or its control system external to the Guardmaster system.
 - a. Check the external fuses in the safety output wiring of the mat manager and replace if necessary.

IMPORTANT Verify that the fuse is correct (2 A max).

- b. Record the replacement in the inspection log. If either fuse blows immediately or requires early replacement, there is a probable fault in the machine control circuit between the safety output of the Guardmaster mat manager and the final control elements (contactors) of the machine.
2. If the Machine Enabled status indicator on the Guardmaster mat manager is off, take the following actions:
 - a. Check that the Power status indicator is illuminated. If it is not, check the power supply to the Guardmaster mat manager.
 - b. Check that the power supply is connected to the appropriate terminals.
 - c. Check the primary and secondary fuses in the mat manager and replace if necessary. Verify that the correct value of fuse is used (500 mA anti-surge for both primary and secondary fuses).

- d. Record the replacement in the inspection log. If either fuse blows immediately or requires early replacement, contact your local Allen-Bradley distributor or Rockwell Automation sales office.
3. If the Machine Enabled status indicator on the Guardmaster mat manager is off and the Power status indicator is on, there is a fault in the system. On dual-channel systems with contactor monitoring, there can be a fault external to the mat manager even if the external safety output fuses have not blown. One fault in either wiring channel can cause the mat manager to lock off the safety outputs until the fault is rectified and the mat manager is reset.
 - a. Check that all connecting wiring in the system is configured correctly and is not damaged, and that both contactors are functioning correctly.
 - b. Rectify any faults and, if in Manual Reset mode, press and release the mat manager Reset button.
4. If the problem is not resolved, contact your local Allen-Bradley distributor or Rockwell Automation sales office.

No Stop

The machine does not stop or can be started with a presence on the safety mat.



ATTENTION: Do not allow use of the machine until the fault is resolved and tested.

Resolution

1. With a presence on the safety mat, the Machine Enabled status indicator illuminates on the Guardmaster mat manager.
If the Machine Enabled status indicator does not illuminate, there is a probable fault on the machine or its control system external to the Guardmaster system.
2. If the Machine Enabled status indicator is illuminated, do not allow use of the machine and contact your local Allen-Bradley distributor or Rockwell Automation sales office immediately.

Unexpected Stoppage

The machine stops unexpectedly with no presence on the safety mat, but can be restarted after stepping on and off the safety mat (and reset, when in Manual Reset mode).

Resolution

1. Check that all status indicator lights are operating correctly. If they are, a dip in supply power of a certain value and duration is likely causing the problem. The dip in supply power can cause one of the internal relays in the mat manager to drop out, which simulates a fault condition. This condition is an unlikely occurrence, and no remedial action is required.
2. If the problem persists, take measures to achieve a smoother power supply to the safety mat system.

Notes:

Specifications

MatGuard Mat Manager Specifications

Table 11 - General Specifications

Attribute	Value	
Standards	EN 13856-1, EN 61508, EN 13849, IEC/EN 60204-1, ANSI RIA R15.06, ANSI B11.19	
PL, Category, SIL	SIL CL 2 per IEC 62061, PLd per ISO 13849-1	
Approvals	CE Marked for all applicable EU directives UKCA Marked for all applicable regulations	
Power supply	440F-C28011 440F-C28024 440F-C28025 440F-C28026	24V DC, -20...+10%
	440F-C28013	24V DC, 115V AC, or 230V AC, -20...+10
	440F-C28012 440F-C28023	115V AC or 230V AC, -20% +10%
Power consumption	9V A or 12 W	
Fuses	Inputs: Internal electronic short circuit protection Safety outputs (external, user supplied): 10 A, fast blow 6 A slow blow	
Safety mat inputs	440F-C28011 440F-C28012 440F-C28013 440F-C28023 440F-C28026	Eight 4-pin micro-QD M12 inputs
	440F-C28024 440F-C28025	Eight cable grips
Not used open inputs	To be disabled via internal micro switches	
Input capacitance per safety mat input	50nf	
Reset mode	Configurable: Automatic/Manual or Monitored Manual on all versions	
Response time	35 ms	
Status indicators	<ul style="list-style-type: none"> Power: Green Machine Enabled: Green Reset (either automatic or manual): Green 	
Safety mat status indicators	<ul style="list-style-type: none"> Run condition - nothing present on safety mat: Green Stop condition - safety mat actuated: Red Safety mat input not used and disabled via switches (off) 	
Operating temperature	-10...+45 °C (14...113 °F)	
Rated insulation voltage	250V (external wiring must be compatible with the rated insulation voltage)	
Contamination level	II	
Impulse withstand voltage	2500V AC	
Relative humidity	90%	
Enclosure protection	Steel, IP65	
Torque settings - main screw	1.3 N•m	
Vibration	0.15 mm (0.01 in.), 10...55Hz	
Shock	10 g, 11 ms, half-sine	
Enclosure mounting	Four M8 mounting hardware through the enclosure mounting tabs	

Table 12 - Outputs

Attribute	Value	
Safety outputs	440F-C28011 440F-C28012 440F-C28013 440F-C28024 440F-C28025 440F-C28026	2 N.O. independent voltage free
	440F-C28023	6 N.O. independent voltage free
Auxiliary outputs	440F-C28011 440F-C28013 440F-C28026	1 N.C. independent voltage free
	440F-C28012 440F-C28024 440F-C28025	1 N.C. independent voltage free
	440F-C28023	1 N.O. independent voltage free
	440F-C28011 440F-C28012 440F-C28013 440F-C28023	4 A/250V AC/1000VA 3 A/30V DC/90 W
Output ratings, max	440F-C28024 440F-C28025	2 A/30V DC/60 W
	440F-C28026	4 A/250V AC/500VA 3 A/30V DC/90 W
Output ratings, min (all models)	10 mA at 10V	

Safety Mat Specifications

Table 13 - Safety Mat Specifications

Attribute	Value
Standards	ISO 13856-1, ISO 13849-1, IEC/EN 60204-1, ANSI B11.19, ANSI RIA R15.06
PL, Category, SIL	Category 1 per EN ISO 13856-1, Suitable for PLd, Cat 3 systems per ISO 13849-1 and SIL CL 2 per IEC 62061 in combination with 440F-C28x MatGuard™ Mat Manager
Operating voltage	24V DC +10...- 20% provided by the mat manager
Weight of person with achievable detection, min	30 kg (66 lb) on an 80 mm (3.125 in.) diameter circular disk.
Detection zone, max	100 m ² (1076 ft ²)
Number of individual safety mats, max	8
Total length of connection wires, max	200 m (656 ft)
Weight	10.9 kg/m ² (2.2 lb/ft ²)
Environmental protection	IP67 (NEMA 6P)
Mechanical life	1,000,000 operations
Humidity	0...100% RH
Color	<ul style="list-style-type: none"> • Yellow • Black
Operating temperature	-10...+55 °C (-14...+131 °F)
Storage temperature	-40...+70 °C (-40...+158 °F)
Storage Orientation	Safety mats must be stored vertically
Thickness	16 mm (0.63 in.)
Size	Add 6 mm (0.24 in.) to nominal size

Spare Part List

Safety Mat Size		Safety Mat	Standard Perimeter Trim Kit
Millimeters	Inches	Cat. No.	Cat. No.
500 x 500	19.7 x 19.7	440F-M1010BYNN	440F-T1010
500 x 600	19.7 x 23.6	440F-M1012BYNN	440F-T1012
500 x 900	19.7 x 35.4	440F-M1018BYNN	440F-T1018
500 x 1000	19.7 x 39.4	440F-M1020BYNN	440F-T1020
500 x 1200	19.7 x 47.2	440F-M1024BYNN	440F-T1024
500 x 1500	19.7 x 59.1	440F-M1030BYNN	440F-T1030
600 x 600	23.6 x 23.6	440F-M1212BYNN	440F-T1212
600 x 750	23.6 x 29.5	440F-M1215BYNN	440F-T1215
600 x 900	23.6 x 35.4	440F-M1218BYNN	440F-T1218
600 x 1000	23.6 x 39.4	440F-M1220BYNN	440F-T1220
600 x 1200	23.6 x 47.2	440F-M1224BYNN	440F-T1224
600 x 1500	23.6 x 59.1	440F-M1230BYNN	440F-T1230
750 x 500	29.5 x 19.7	440F-M1510BYNN	440F-T1510
750 x 750	29.5 x 29.5	440F-M1515BYNN	440F-T1515
750 x 1500	29.5 x 59.1	440F-M1530BYNN	440F-T1530
800 x 600	31.5 x 23.6	440F-M1612BYNN	440F-T1612
800 x 750	31.5 x 29.5	440F-M1615BYNN	440F-T1615
800 x 900	31.5 x 35.4	440F-M1618BYNN	440F-T1618
800 x 1000	31.5 x 39.4	440F-M1620BYNN	440F-T1620
800 x 1200	31.5 x 47.2	440F-M1624BYNN	440F-T1624
800 x 1500	31.5 x 59.1	440F-M1630BYNN	440F-T1630
900 x 900	35.4 x 35.4	440F-M1818BYNN	440F-T1818
900 x 1000	35.4 x 39.4	440F-M1820BYNN	440F-T1820
900 x 1200	35.4 x 47.2	440F-M1824BYNN	440F-T1824
900 x 1500	35.4 x 59.1	440F-M1830BYNN	440F-T1830
1000 x 750	39.4 x 29.5	440F-M2015BYNN	440F-T2015
1000 x 1000	39.4 x 39.4	440F-M2020BYNN	440F-T2020
1000 x 1200	39.4 x 47.2	440F-M2024BYNN	440F-T2024
1000 x 1250	39.4 x 49.2	440F-M2025BYNN	440F-T2025
1000 x 1500	39.4 x 59.1	440F-M2030BYNN	440F-T2030

Item	Specification	Cat. No.
Standard perimeter trim	2 m (6.56 ft)	440F-T3210
	3 m (9.84 ft)	440F-T3310
	5 m (16.4 ft)	440F-T3510
External corner standard perimeter trim	-	440F-T3012
Internal corner standard perimeter trim	-	440F-T3013
Perimeter trim with cable channel	2 m (6.56 ft)	440F-T3211
	4 m (13.12 ft)	440F-T3411
External corner perimeter trim with cable channel	-	440F-T3014
Internal corner perimeter trim with cable channel	-	440F-T3015
Active uniting trim	-	440F-T3020
Vinyl wire guide	-	440F-T3230
Safety mat controllers	-	440F-C4000P 440F-C4000S 440F-C4000D 440F-C28013
Fuse	500 mA	440R-A31562
Shorting plug	-	440F-A28639

A

active uniting trim 14, 34
application 61
arc suppression 29
auxiliary output 29

B

bypass
measures against 23

C

calculation
safety distance 23
check
electrical function 54
mechanical installation 53
checkout
functional 55
cleaning
mat 57
commission 31
components
system 13
connection
flying lead 42
individual mat 39
mat M12 QD 41

D

design
system 19
dimension
mat manager 67
sensor mat 33, 67
dismantle 58
dispose 58

E

electrical function
check 54
electrical interface 26
environment 20
error
internal 62

F

fixed guard 23
flying lead
connection 42
functional checkout 55

G

good design practice 24
guard
fixed 23

H

hazard
nature 19

I

individual mat
connection 39
inspection
routine 57
thorough 58
install 31
installation
mat 31
mat manager 35
mechanical 53
interface
electrical 26
internal error 62

L

layout
sensor mat 29

M

maintenance 57
mat
cleaning 57
connection 39
dimension 33, 67
installation 31
layout 29
M12 QD connection 41
position 20
selection 40
mat manager
dimension 67
installation 35
wiring 35
MatGuard mat manager
specification 65
mats 14
measures against bypass 23
mechanical installation
check 53

N

nature of hazard 19
nature of safeguarding 19

O

output
auxiliary 29
overview
product 13

P

perimeter trim 14, 34
position
mat 20
power supply
select 27
presence sensing system
guarded perimeter 22
product overview 13

R

repair 59
routine
inspection and test 57

S

safeguarding
nature 19
safety distance
calculation 23
select
power supply 27
selection
mat 40
sensor mat
dimension 33, 67
specification 66
sensor mat layout 29
service 59
specifications 65
MatGuard mat manager 65
sensor mat 66
suppression
arc 29
system
design 19
presence sensing (guarded perimeter) 22
system components 13
system design
requirement 23

T

test
routine 57
thorough 58
thorough
inspection and test 58
trim
perimeter 14, 34
uniting 14, 34
troubleshoot 59

U

uniting trim
active 14, 34
use 55

W

wiring
mat manager 35

Rockwell Automation Support

Use these resources to access support information.

Technical Support Center	Find help with how-to videos, FAQs, chat, user forums, and product notification updates.	rok.auto/support
Knowledgebase	Access Knowledgebase articles.	rok.auto/knowledgebase
Local Technical Support Phone Numbers	Locate the telephone number for your country.	rok.auto/phonesupport
Literature Library	Find installation instructions, manuals, brochures, and technical data publications.	rok.auto/literature
Product Compatibility and Download Center (PCDC)	Download firmware, associated files (such as AOP, EDS, and DTM), and access product release notes.	rok.auto/pcdc

Documentation Feedback

Your comments help us serve your documentation needs better. If you have any suggestions on how to improve our content, complete the form at rok.auto/docfeedback.

Waste Electrical and Electronic Equipment (WEEE)







At the end of life, this equipment should be collected separately from any unsorted municipal waste.

Rockwell Automation maintains current product environmental information on its website at rok.auto/pec.

Allen-Bradley, expanding human possibility, CompactBlock, Guard I/O, GuardLogix, Guardmaster, MatGuard, POINT Guard I/O, Rockwell Automation, and SmartGuard are trademarks of Rockwell Automation, Inc.

Trademarks not belonging to Rockwell Automation are property of their respective companies.

Rockwell Otomasyon Ticaret A.Ş. Kar Plaza İş Merkezi E Blok Kat:6 34752, İçerenköy, İstanbul, Tel: +90 (216) 5698400 EEE Yönetmeliğine Uygundur

Connect with us.    

rockwellautomation.com — expanding **human possibility**[®]

AMERICAS: Rockwell Automation, 1201 South Second Street, Milwaukee, WI 53204-2496 USA, Tel: (1) 414.382.2000

EUROPE/MIDDLE EAST/AFRICA: Rockwell Automation NV, Pegasus Park, De Kleetlaan 12a, 1831 Diegem, Belgium, Tel: (32) 2663 0600

ASIA PACIFIC: Rockwell Automation SEA Pte Ltd, 2 Corporation Road, #04-05, Main Lobby, Corporation Place, Singapore 618494, Tel: (65) 6510 6608

UNITED KINGDOM: Rockwell Automation Ltd., Pitfield, Kiln Farm, Milton Keynes, MK11 3DR, United Kingdom, Tel: (44)(1908) 838-800

Publication 440F-UM001B-EN-P - January 2024

Supersedes Publication Supersedes Publication 440F-UM001A-EN-P - May 2019

Copyright © 2024 Rockwell Automation, Inc. All rights reserved. Printed in the U.S.A.