

version with featherkey

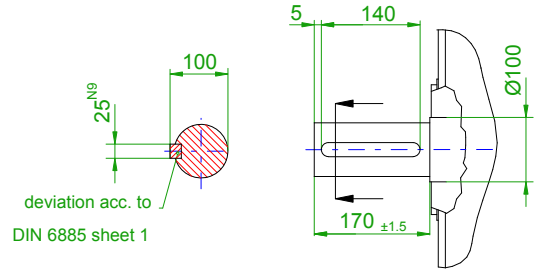
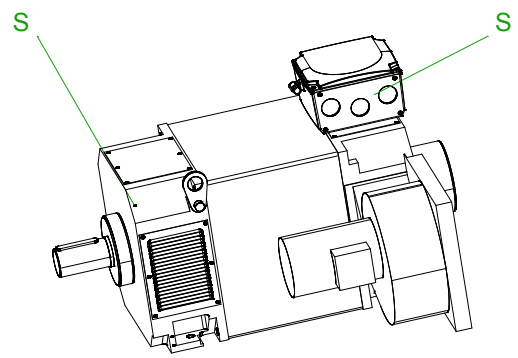

- A - Separately driven fan with grid, FM - fan motor
- GS - Connector for pulse generator and temperature sensor
- XA - Relief groove E2,5x0,4 to DIN509
- K1 - Terminal Box for fan motor
- M10 - Cable Entry 2xM20x1,5
- K - Terminal box
- M - Cable entry 3x M75x1,5
- WA - Shaft extension 95 m6x170-0,5 to DIN 748, tapped centre hole DR M24 to DIN332
- LE - Air inlet, LA - Air outlet
- E - Ground Clamp
- H - Lifting eye - do only with traverse
- S - Greasing nipple

Type of protection IP 23
 Type of construction IM B3 (IM V6)

Einheit / unit: mm	Asynchron-Servomotor Asynchronous Servo Motor
nicht tolerierte Maße / not toleranced dimensions:	Optionen / options: G02
Maßstab / scale: ohne / without	Gewicht / mass: 1200 kg
CAD CREATOR 2.2 (WWW-Version V02.20.00.00)	Bemerkung / notice:
	Druckdatum / print date: 05.02.2020