

SIEMENS



Motion Control Drives

SINAMICS S210 Servo Drive System

Catalog
D 32

US
Edition
April 2019

[siemens.com/drives](https://www.siemens.com/drives)

Related catalogs

<p>Motion Control Drives D 31.1 SINAMICS Inverters for Single-Axis Drives Built-In Units</p> <p>E86060-K5531-A111-A1-7600</p>		<p>Industrial Controls IC 10 SIRIUS</p> <p>PDF (E86060-K1010-A101-A9-7600)</p>	
<p>Motion Control Drives D 31.2 SINAMICS Inverters for Single-Axis Drives Distributed Inverters</p> <p>E86060-K5531-A121-A1-7600</p>		<p>Industrial Controls IC 10 AO SIRIUS Classic</p> <p>PDF (E86060-K1010-A191-A5-7600)</p>	
<p>SINAMICS S120 D 21.3 Chassis Format Converter Units Cabinet Modules</p> <p>SINAMICS S150 Converter Cabinet Units E86060-K5521-A131-A6-7600</p>		<p>Low-Voltage Power Distribution and Electrical Installation Technology LV 10 SENTRON • SIVACON • ALPHA Protection, Switching, Measuring and Monitoring Devices, Switchboards and Distribution Systems</p> <p>PDF (E86060-K8280-A101-A8-7600) Print (E86060-K8280-A101-A6-7600)</p>	
<p>Motion Control Drives D 21.4 SINAMICS S120 and SIMOTICS</p> <p>E86060-K5521-A141-A1-7600</p>		<p>SIMATIC ST 70 Products for Totally Integrated Automation</p> <p>PDF (E86060-K4670-A101-B7-7600)</p>	
<p>SIMOTICS S-1FG1 D 41 Servo geared motors Helical, Parallel shaft, Bevel and Helical worm geared motors</p> <p>PDF (E86060-K5541-A101-A4-7600)</p>		<p>SIMATIC HMI / PC-based Automation ST 80/ST PC Human Machine Interface Systems PC-based Automation</p> <p>E86060-K4680-A101-C6-7600</p>	
<p>SIMOTICS GP, SD, XP, DP D 81.1 Low-Voltage Motors Type series 1FP1, 1LE1, 1LE5, 1MB1 and 1PC1 Frame sizes 63 to 355 Power range 0.09 to 500 kW E86060-K5581-A111-B2-7600</p>		<p>Industrial Communication IK PI SIMATIC NET</p> <p>E86060-K6710-A101-B8-7600</p>	
<p>FLENDER Couplings MD 10.1 Standard Couplings</p> <p>E86060-K5710-A111-A5-7600</p>		<p>Products for Automation and Drives CA 01 Interactive Catalog Download</p> <p>www.siemens.com/automation/ca01</p>	
<p>SIMOGEAR MD 50.1 Geared Motors Helical, parallel shaft, bevel, helical worm and worm geared motors</p> <p>E86060-K5250-A111-A5-7600</p>		<p>Industry Mall Information and Ordering Platform on the Internet:</p> <p>www.siemens.com/industrymall</p>	
<p>Motion Control System PM 21 SIMOTION Equipment for Production Machines</p> <p>E86060-K4921-A101-A4-7600</p>			

SINAMICS S210 Servo Drive System

Motion Control Drives



Catalog D 32 · April 2019

Supersedes:
Catalog D 32 · September 2018

Refer to the Industry Mall for current updates of
this catalog:

www.siemens.com/industrymall

The products contained in this catalog can also be found
in the Interactive Catalog CA 01.

The Catalog CA 01 can be downloaded at:

www.siemens.com/automation/ca01

Please contact your local Siemens branch.

© Siemens 2019

NEW

Click on an Article No. in the catalog PDF to call it up in the
Industry Mall and to obtain all the information.

Article No.

6SL3070-0AA00-0AG0
6SL3072-0AA00-0AG0



Or directly on the Internet, e.g.
www.siemens.com/product?6SL3070-0AA00-0AG0



The products and systems described in
this catalog are manufactured/distributed
under application of a certified quality
management system in accordance with
DIN EN ISO 9001. The certificate is
recognized by all IQNet countries.

System overview

1

SINAMICS S210 servo drive

2

SIMOTICS S-1FK2 servomotors

3

MOTION-CONNECT connection systems

4

Engineering tools

5

Services and documentation

6

Appendix

7

Digital Enterprise

The building blocks that ensure everything works together perfectly in the digital enterprise

Digitalization is already changing all areas of life and existing business models. It is placing greater pressure on industry while at the same time creating new business opportunities. Today, thanks to scalable solutions from Siemens, companies can already become a digital enterprise and ensure their competitiveness.



Industry faces tremendous challenges



Reduce time-to-market

Today manufacturers have to bring products to market at an ever-increasing pace despite the growing complexity of these products. In the past, a major manufacturer would push aside a small one, but now it is a fast manufacturer that overtakes a slow one.



Boost flexibility

Consumers want customized products, but at a price they would pay for a mass-produced item. That only works if production is more flexible than ever before.



Improve quality

To ensure a high level of quality while meeting legal requirements, companies have to establish closed quality loops and enable the traceability of products.

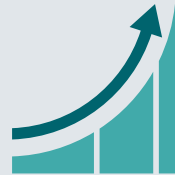

Boost efficiency

Today the product itself needs to be sustainable and environmentally friendly, while energy efficiency in production has become a competitive advantage.



Increase security

Increasing networking escalates the threat to production facilities of cyberattacks. Today more than ever, companies need suitable security measures.



The digital enterprise has already become a reality

To fully benefit from all the advantages of digitalization, companies first have to achieve complete consistency of their data. Fully digitally integrated business processes, including those of suppliers, can help to create a digital representation of the entire value chain. This requires

- the integration of industrial software and automation,
- expansion of the communication networks,
- security in automation,
- and the use of business-specific industrial services.

MindSphere

The cloud-based open IoT operating system from Siemens

With MindSphere, Siemens offers a cost-effective and scalable cloud platform as a service (PaaS) for the development of applications. The platform, designed as an open operating system for the Internet of Things, makes it possible to improve the efficiency of plants by collecting and analyzing large volumes of production data.

Totally Integrated Automation (TIA) Where digitalization becomes reality

Totally Integrated Automation (TIA) ensures the seamless transition from the virtual to the real world. It already encompasses all the necessary conditions for transforming the benefits of digitalization into true added value. The data that will form the digital twin for actual production is generated from a common base.

Digital Plant

Learn more about the digital enterprise for the process industry
www.siemens.com/digitalplant

Digital Enterprise Suite

Learn more about the digital enterprise for the discrete industry
www.siemens.com/digital-enterprise-suite

Integrated Drive Systems

Faster on the market and in the black with Integrated Drive Systems

Integrated Drive Systems are Siemens' trendsetting answer to the high degree of complexity that characterizes drive and automation technology today. The world's only true one-stop solution for entire drive systems is characterized in particular by its threefold integration: Horizontal, vertical, and lifecycle integration ensure that every drive system component fits seamlessly into the whole system, into any automation environment, and even into the entire lifecycle of a plant.

The outcome is an optimal workflow – from engineering all the way to service that entails more productivity, increased efficiency, and better availability. That's how Integrated Drive Systems reduce time to market and time to profit.

Horizontal integration

Integrated drive portfolio: The core elements of a fully integrated drive portfolio are frequency converters, motors, couplings, and gear units. At Siemens, they're all available from a single source. Perfectly integrated, perfectly interacting. For all power and performance classes. As standard solutions or fully customized. No other player in the market can offer a comparable portfolio. Moreover, all Siemens drive components are perfectly matched, so they are optimally interacting.

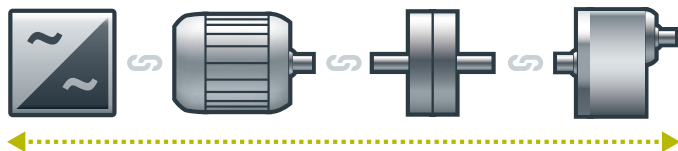

You can boost the availability of your application or plant to up to

99%*

*e.g., conveyor application

Vertical integration

Thanks to **vertical integration**, the complete drive train is seamlessly integrated in the entire automation environment – an important prerequisite for production with maximum value added. Integrated Drive Systems are part of Totally Integrated Automation (TIA), which means that they are perfectly embedded into the system architecture of the entire industrial production process. This enables optimal processes through maximum communication and control.

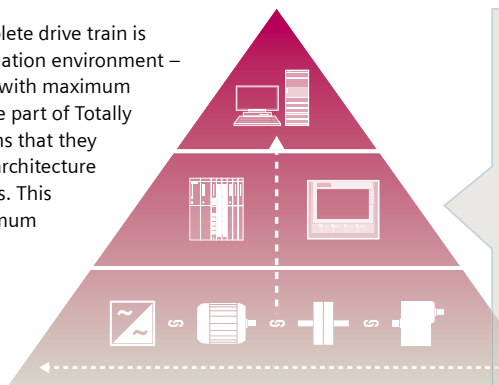

With TIA Portal you can cut your engineering time by up to

30%

Lifecycle integration

Lifecycle integration adds the factor of time: Software and service are available for the entire lifecycle of an Integrated Drive System. That way, important optimization potential for maximum productivity, increased efficiency, and highest availability can be leveraged throughout the system's lifecycle – from planning, design, and engineering to operation, maintenance, and all the way even to modernization.

With Integrated Drive Systems, assets become important success factors. They ensure shorter time to market, maximum productivity and efficiency in operation, and shorter time to profit.

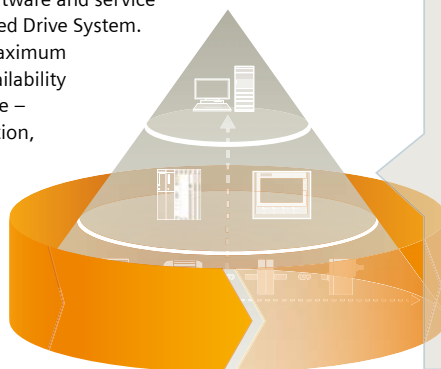

With Integrated Drive Systems you can reduce your maintenance costs by up to

15%

System overview



1/2	The SINAMICS converter family
1/6	Drive selection
1/7	SINAMICS S210 servo drive system
1/13	Order overview
1/18	SINAMICS S210 starter kit

System overview

The SINAMICS converter family

Overview

Integration in automation

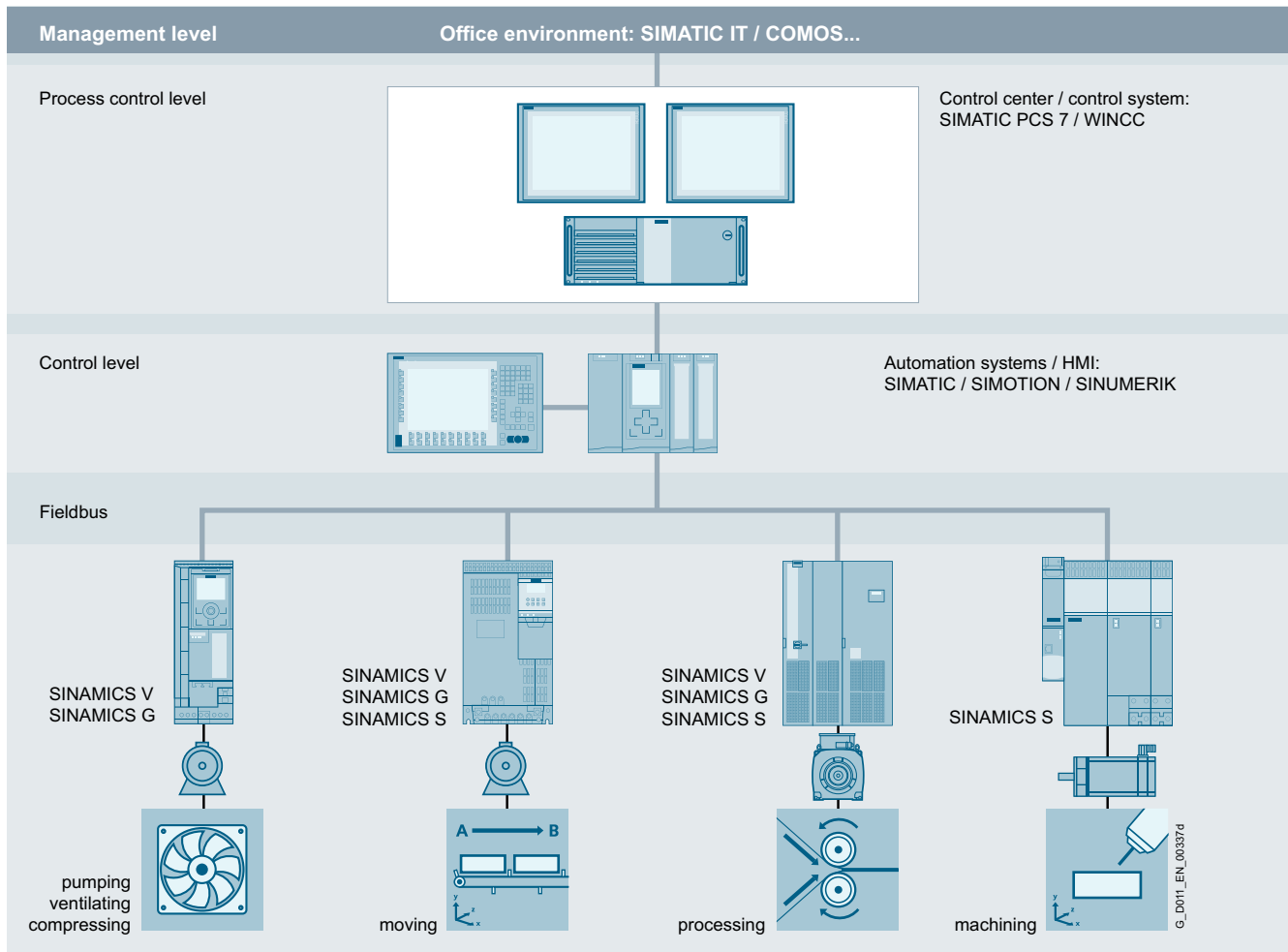

Totally Integrated Automation and communication

SINAMICS is an integral component of the Siemens "Totally Integrated Automation" concept. Integrated SINAMICS systems covering configuration, data storage, and communication at automation level ensure low-maintenance solutions with the SIMATIC, SIMOTION and SINUMERIK control systems.

Depending on the application, the appropriate variable frequency drives can be selected and incorporated in the automation concept. With this in mind, the drives are clearly subdivided into their different applications. A wide range of communication options (depending on the drive type) are available for establishing a communication link to the automation system:

- PROFINET
- PROFIBUS
- EtherNet/IP
- Modbus TCP
- Modbus RTU
- AS-Interface
- BACnet MS/TP

Applications

SINAMICS is the comprehensive converter family from Siemens designed for machine and plant engineering applications. SINAMICS offers solutions for all drive tasks:

- Simple pump and fan applications in the process industry
- Demanding single drives in centrifuges, presses, extruders, elevators, as well as conveyor and transport systems
- Drive line-ups in textile, plastic film, and paper machines as well as in rolling mill plants
- Highly dynamic servo drives for machine tools, as well as packaging and printing machines

Overview (continued)*SINAMICS as part of the Siemens modular automation system****Innovative, energy-efficient and reliable drive systems and applications as well as services for the entire drive train***

The solutions for drive technology place great emphasis on the highest productivity, energy efficiency and reliability for all torque ranges, performance and voltage classes.

Siemens offers not only the right innovative variable frequency drive for every drive application, but also a wide range of energy-efficient low-voltage motors, geared motors, explosion-protected motors and high-voltage motors for combination with SINAMICS.

Furthermore, Siemens supports its customers with global pre-sales and after-sales services, with over 295 service points in 130 countries – and with special services e.g. application consulting or motion control solutions.

Energy efficiency***Energy management process***

Efficient energy management consultancy identifies the energy flows, determines the potential for making savings and implements them with focused activities.

Almost two thirds of the industrial power requirement is from electric motors. This makes it all the more important to use drive technology permitting energy consumption to be reduced effectively even in the configuration phase, and consequently to optimize plant availability and process stability. With SINAMICS, Siemens offers powerful energy efficient solutions which, depending on the application, enable a significant reduction in electricity costs.

System overview

The SINAMICS converter family

Overview (continued)

Up to 70 % potential for savings using variable-speed operation

SINAMICS enables great potential for savings to be realized by controlling the motor speed. In particular, huge potential savings can be recovered from pumps, fans and compressors which are operated with mechanical throttle and valves. Here, changing to variable-speed drives brings enormous economic advantages. In contrast to mechanical control systems, the power consumption at partial load operation is always immediately adjusted to the demand at that time. So energy is no longer wasted, permitting savings of up to 60 % – in exceptional cases even up to 70 %. Variable-speed drives also offer clear advantages over mechanical control systems when it comes to maintenance and repair. Current spikes when starting up the motor and strong torque surges become things of the past – and the same goes for pressure waves in pipelines, cavitation or vibrations which cause sustainable damage to the plant. Smooth starting and ramp-down relieve the load on the mechanical system, ensuring a significantly longer service life of the entire drive train.

Regenerative feedback of braking energy

In conventional drive systems, the energy produced during braking is converted to heat using braking resistors. Energy produced during braking is efficiently recovered to the supply system by versions of SINAMICS G and SINAMICS S drives with regenerative feedback capability and these devices do not therefore need a braking resistor. This permits up to 60 % of the energy requirement to be saved, e.g. in lifting applications. Energy which can be reused at other locations on a machine. Furthermore, this reduced power loss simplifies the cooling of the system, enabling a more compact design.

Energy transparency in all configuration phases

Early on, in the configuration phase, the SIZER for Siemens Drives engineering tool provides information on the specific energy requirement. The energy consumption across the entire drive train is visualized and compared with different plant concepts.

SINAMICS in combination with energy-saving motors

Engineering integration stretches beyond the SINAMICS converter family to higher-level automation systems, and to a broad spectrum of energy-efficient motors with a wide range of performance classes, which, compared to previous motors, are able to demonstrate up to 10 % greater efficiency.

Variants

Depending on the application, the SINAMICS converter family offers the ideal variant for any drive task.

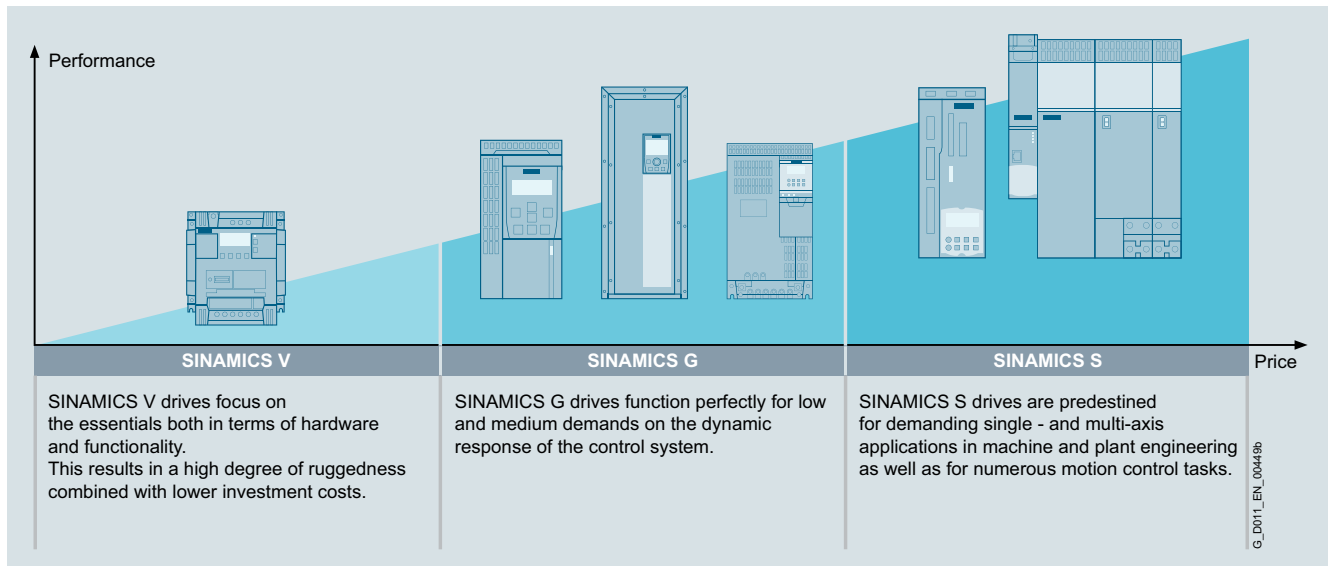

Overview (continued)

Platform concept

All SINAMICS variants are based on a platform concept. Joint hardware and software components, as well as standardized tools for dimensioning, configuration, and commissioning tasks ensure high-level integration across all components. SINAMICS handles a wide variety of drive tasks with no system gaps. The different SINAMICS variants can be easily combined with each other.













Quality management according to EN ISO 9001

SINAMICS conforms to the most exacting quality requirements. Comprehensive quality assurance measures in all development and production processes ensure a consistently high level of quality.

Of course, our quality management system is certified by an independent authority in accordance with EN ISO 9001.

IDS – Integration at its very best

The Siemens Integrated Drive Systems (IDS) solution offers perfectly matched drive components with which you can meet your requirements. The drive components reveal their true strengths as an Integrated Drive System over the full range from engineering and commissioning through to operation: Integrated system configuration is performed using the Drive Technology Configurator: Just select a motor and a converter and design them with the SIZER for Siemens Drives engineering tool. The STARTER and SINAMICS Startdrive commissioning tools integrate the motor data and at the same time simplify efficient commissioning. Integrated Drive Systems are incorporated in the TIA Portal – this simplifies engineering, commissioning and diagnostics.

Low voltage										DC voltage	Medium voltage
Basic performance		General performance					High performance			DC applications	Applications with high outputs
											
SINAMICS V20	SINAMICS V90	SINAMICS G120C G120 G120X	SINAMICS G110D G120D G110M SIMATIC ET 200pro FC-2	SINAMICS G130 G150	SINAMICS G180	SINAMICS S110	SINAMICS S210	SINAMICS S120 S120M	SINAMICS S150	SINAMICS DCM	SINAMICS GH150 GH180 GM150 SM150 GL150 SL150 SM120CM
0.12 kW to 30 kW	0.05 kW to 7 kW	0.37 kW to 630 kW	0.37 kW to 7.5 kW	75 kW to 2700 kW	2.2 kW to 6600 kW	0.55 kW to 132 kW	0.05 kW to 7 kW	0.55 kW to 5700 kW	75 kW to 1200 kW	6 kW to 30 MW	0.15 MW to 85 MW
Pumps, fans, compressors, conveyor belts, mixers, mills, spinning machines, textile machines, refrigerated display counters, fitness equipment, ventilation systems	Handling machines, packaging machines, automatic assembly machines, metal forming machines, printing machines, winding and unwinding units	Pumps, fans, compressors, conveyor belts, mixers, mills, extruders, building management systems, process industry, HVAC, single-axis positioning applications in machine and plant engineering	Conveyor technology, single-axis positioning applications (G120D)	Pumps, fans, compressors, conveyor belts, mixers, mills, extruders	Sector-specific for pumps, fans, compressors, conveyor belts, extruders, mixers, mills, kneaders, centrifuges, separators	Single-axis positioning applications in machine and plant engineering	Packaging machines, handling equipment, feed and withdrawal devices, stacking units, automatic assembly machines, laboratory automation, wood, glass and ceramics industry, digital printing machines	Production machines (packaging, textile and printing machines, paper machines, plastic processing machines), machine tools, plants, process lines and rolling mills, marine drives, test bays	Test bays, cross cutters, centrifuges	Rolling mill drives, wire-drawing machines, extruders and kneaders, cableways and lifts, test bay drives	Pumps, fans, compressors, mixers, crushers, rolling mills, conveyor technology, excavators, test bays, marine drives, blast furnace fans, retrofit
Catalog D 31.1	Catalog D 33	Catalogs D 31.1, D 31.5	Catalog D 31.2	Catalog D 11	Catalog D 18.1	Catalog D 31.1	Catalog D 32	Catalogs D 21.3, D 21.4 NC 62	Catalog D 21.3	Catalog D 23.1	Catalogs D 15.1, D 12

Engineering tools (e.g. Drive Technology Configurator, SIZER for Siemens Drives, STARTER and SINAMICS Startdrive)

G_D011_EN_00450m

System overview

Drive selection

1

Overview

SINAMICS selection guide – typical applications

Use	Requirements for torque accuracy/speed accuracy/position accuracy/coordination of axes/functionality					
	Continuous motion			Non-continuous motion		
	Basic	Medium	High	Basic	Medium	High
Pumping, ventilating, compressing 	Centrifugal pumps Radial / axial fans Compressors V20 G120C G120X	Centrifugal pumps Radial / axial fans Compressors G120X G130/G150 G180 ¹⁾	Eccentric screw pumps S120	Hydraulic pumps Metering pumps G120	Hydraulic pumps Metering pumps S110	Descaling pumps Hydraulic pumps S120
Moving 	Conveyor belts Roller conveyors Chain conveyors V20 G110D G110M G120C ET 200pro FC-2 ²⁾	Conveyor belts Roller conveyors Chain conveyors Lifting/lowering devices Elevators Escalators/moving walkways Indoor cranes Marine drives Cable railways G120 G120D G130/G150 G180 ¹⁾	Elevators Container cranes Mining hoists Excavators for open-cast mining Test bays S120 S150 DCM	Acceleration conveyors Storage and retrieval machines V90 G120 G120D	Acceleration conveyors Storage and retrieval machines Cross cutters Reel changers S110 S210 DCM	Storage and retrieval machines Robotics Pick & place Rotary indexing tables Cross cutters Roll feeds Engagers/disengagers S120 S210 DCM
Processing 	Mills Mixers Kneaders Crushers Agitators Centrifuges V20 G120C	Mills Mixers Kneaders Crushers Agitators Centrifuges Extruders Rotary furnaces G120 G130/G150 G180 ¹⁾	Extruders Winders/unwinders Lead/follower drives Calenders Main press drives Printing machines S120 S150 DCM	Tubular bagging machines Single-axis motion control such as • Position profiles • Path profiles V90 G120	Tubular bagging machines Single-axis motion control such as • Position profiles • Path profiles S110 S210	Servo presses Rolling mill drives Multi-axis motion control such as • Multi-axis positioning • Cams • Interpolations S120 S210 DCM
Machining 	Main drives for • Turning • Milling • Drilling S110	Main drives for • Drilling • Sawing S110 S120	Main drives for • Turning • Milling • Drilling • Gear cutting • Grinding S120	Axis drives for • Turning • Milling • Drilling S110	Axis drives for • Drilling • Sawing S110 S120	Axis drives for • Turning • Milling • Drilling • Lasering • Gear cutting • Grinding • Nibbling and punching S120

Using the SINAMICS selection guide

The varying range of demands on modern variable frequency drives requires a large number of different types. Selecting the optimum drive has become a significantly more complex process. The application matrix shown simplifies this selection process considerably, by suggesting the ideal SINAMICS drive for examples of typical applications and requirements.

- The application type is selected from the vertical column
 - Pumping, ventilating, compressing
 - Moving
 - Processing
 - Machining
- The quality of the motion type is selected from the horizontal row
 - Basic
 - Medium
 - High

More Information

Further information about SINAMICS is available on the Internet at www.siemens.com/sinamics

Practical application examples and descriptions are available on the Internet at www.siemens.com/sinamics-applications

¹⁾ Industry-specific converters.

²⁾ Information on the SIMATIC ET 200pro FC-2 frequency converter is available in Catalog D 31.2 and at: www.siemens.com/et200pro-fc

Overview



Example: SINAMICS S210 converter frame size FSB, 200 V 1 AC, with SIMOTICS S-1FK2 servomotor shaft height 30



Example: SINAMICS S210 converter frame size FSB, 400 V 3 AC, with SIMOTICS S-1FK2 servomotor shaft height 63

The new servo drive system comprises a SINAMICS S210 servo converter, a SIMOTICS S-1FK2 servomotor and a matching One Cable Connection (OCC) for connecting the motor to the converter. The SINAMICS S210 is a single-axis AC/AC servo converter system with high performance and dynamic response for mid-range Motion Control applications.

SINAMICS S210 servo converters are available for the following line voltages:

- 200 V to 240 V 1 AC (1 AC series)
- 200 V to 480 V 3 AC (3 AC series)

The SIMOTICS S-1FK2 servomotors are available for 200 V to 240 V with a torque range from 0.16 Nm to 2.4 Nm and with shaft heights 20 to 40.

For 380 V to 480 V, motors with a torque range from 1.27 Nm to 3.2 Nm and the shaft height 40 are available.

The motors are available in the High Dynamic (HD) and Compact (CT) designs.

Additional SIMOTICS S-1FK2 servomotors with shaft heights of 48 to 100 (up to 40 Nm) and suitable SINAMICS S210 servo converters plus MOTION-CONNECT connection systems will be available soon.

The SINAMICS S210 can be used in numerous applications. Typical applications are:

- Packaging machines
- Handling equipment
- Feed and withdrawal devices
- Stacking units
- Automatic assembly machines
- Laboratory automation
- Woodworking, glass and ceramic industries
- Digital printing machines

Flexible in application

The SINAMICS S210 is a flexible, versatile system. SIMOTICS S-1FK2 series synchronous servomotors are installed in rotary and linear axes. The integrated One Cable Connection (OCC) interface allows user-friendly connection of a SIMOTICS S-1FK2 motor with just one cable. The electronic motor type plate data can be read out, which eliminates the need to parameterize the converter with the motor data. This significantly simplifies and shortens commissioning.

In conjunction with the technological functions of the higher-level controller, there are many possibilities of motion – from continuous operation through positioning and synchronous operation, to coordinated motion of multiple axes via cyclic cams or interpolation – everything is possible.

The SINAMICS S210 converter has an integrated PROFINET communications interface for connecting to a control system.

The data exchange with the higher-level controllers takes place via standardized protocols – the PROFIdrive profile for positioning mode and the PROFIsafe profile for safety-related communication.

Thus, operation is optimally ensured with the SIMATIC S7 automation system. The drive axis is connected via technology objects and Motion Control blocks in the SIMATIC S7 or a SIMOTION controller.

High performance for fast and precise control

The high performance of the SINAMICS S210 servo drive system in conjunction with the SIMOTICS S-1FK2 servomotor derives from the following features:

- Low moment of inertia and high overload capability of the motor
- High-resolution encoder with fast scanning
- Current controller clock cycle of 62.5 μ s and a pulse frequency of 8 kHz of the servo converter

This enables short cycle times on the machine even with complex motion control.

DC link coupling (only 3 AC series)

For devices of the 3 AC series, the DC links of up to six converters can be coupled. Thus, energy balancing between the axes is possible and energy produced during braking can be used by other axes for accelerating. This is not only efficient but also reduces the dissipated heat in the control cabinet, because the energy that is produced no longer has to be converted to heat in the braking resistor.

System overview

SINAMICS S210 servo drive system

1

Overview (continued)

Optimized connection technology with One Cable Connection (OCC)



Example: SINAMICS S210 M12 OCC connecting cable

Motor and converter are simply connected to one another by one instead of the usual two or three cables. With this One Cable Technology, energy supply, encoder signals and braking signal are brought together in a single cable. This results in the following advantages:

- Time-saving by laying only one cable
- Smaller installation space and space requirement in cable collars, tight bending radii
- Only one cable has to be cleaned. This is advantageous, e.g. in the pharmaceutical industry and where higher requirements are placed upon hygiene
- Can be ordered to the decimeter
- M12 (smallest OCC in the world) on the motor side, M17 connection plug (M23 available soon)
- Rotatable connector on the motor side
- Motor with very low interfering contour for restricted installation space.

Cables are available in two different qualities:

- MOTION-CONNECT 500
- MOTION-CONNECT 800PLUS

In addition to the pre-assembled cable, individual components (connectors and products sold by the meter) can be ordered for self-assembly (available soon).

Easy commissioning via web server, One Button Tuning and SINAMICS Startdrive/TIA Portal (V15.1 or higher)

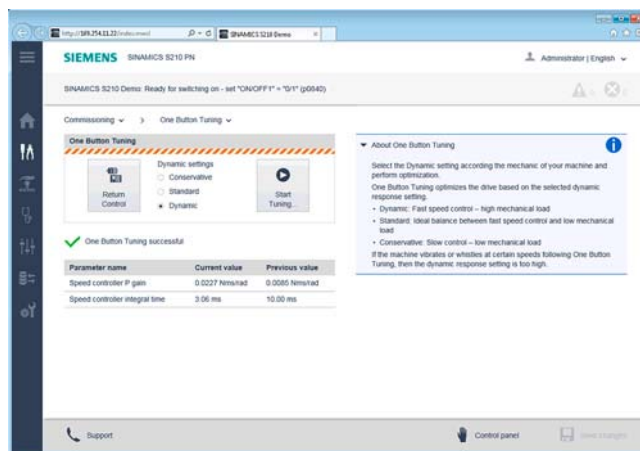

One Button Tuning

The web server of the converter offers a simple means of parameter assignment. The web server allows commissioning purely oriented on the functionality of the drive. With the web server, the SINAMICS S210 servo drive system can be brought into operation with a few clicks.

As a result of reading the electronic type plate of the connected SIMOTICS S-1FK2 servomotor, only a few operator actions, such as automatic controller optimization with One Button Tuning, are necessary, as the motor and encoder are automatically detected. The controller parameters are automatically optimized. The three selectable dynamic levels of the controller can optimally take into account the desired behavior of the connected mechanics.

A motion of the axis can take place directly via the control panel during commissioning.

The customer benefits from the web server in many ways:

- Commissioning can also be easily done in places difficult to access, as the web server in the converter can also be accessed directly via PROFINET from the controller.
- The web server provides full diagnostic capability without the need for additional software.
- Commissioning and diagnostics can also be done without a cable via mobile devices, such as laptops, smart phones and tablets (an additional WLAN access point is necessary).
- Intuitive user interface

In addition to easy commissioning directly via the web server of the converter, engineering is also possible with SINAMICS Startdrive and TIA Portal (V15.1 or higher). The tool for configuration, commissioning and diagnostics has been optimized with regard to the consistent utilization of the TIA Portal advantages – one shared work environment for PLC, HMI and drives. SINAMICS firmware V5.2 or higher is required for SINAMICS S210 devices.

For more information, see the [Engineering tools section](#).

Overview (continued)**Diagnostics**

Faults and warnings are shown on the display located under the front cover, and they can be acknowledged with the Acknowledge button. Extensive diagnostics with plain text messages for cause and remedy information is possible via the web server.

Safety Integrated

The integrated safety functions provide highly effective, application-oriented protection for personnel and machinery (terms as defined in IEC 61800-5-2).

The following Safety Integrated Basic Functions are included as standard:

- Safe Torque Off (STO)
- Safe Brake Control (SBC)
- Safe Stop 1 (SS1)

The following Safety Integrated Extended Functions ¹⁾ are available as options:

- Safe Stop 2 (SS2)
- Safe Operating Stop (SOS)
- Safely-Limited Speed (SLS)
- Safe Speed Monitor (SSM)
- Safe Direction (SDI)
- Safely-Limited Acceleration (SLA)
- Safe Brake Test (SBT) diagnostic function

The Safety Integrated Functions are fully integrated into the drive system. They can be activated via fail-safe digital inputs on the converter (only STO and SS1) or via PROFINET with PROFIsafe.

The Safety Integrated Functions are implemented electronically and therefore require no additional installation effort or space in the control cabinet. Furthermore, the costs are considerably lower than for externally implemented monitoring functions.

The Safety Integrated Functions can be easily commissioned using the web server of the converter or SINAMICS Startdrive/TIA Portal V15.1 or higher.

**Perfect combination with
SIMATIC S7-1500, SIMATIC S7-1500 T-CPU,
SIMATIC ET 200SP Open Controller, and PROFINET**

It communicates with the higher-level control via PROFINET IRT. For optimal interaction between the controller and the SINAMICS S210 servo drive system, SIMATIC S7-1500, SIMATIC S7-1500 T-CPU, SIMATIC ET 200SP Open Controller, and SIMOTION can be used as the control system.

The SINAMICS S210 servo converter has an integrated PROFINET communications interface with a cycle of up to 250 µs for connecting to a control system.

Standardized protocols for linking to a higher-level control with RT and IRT are supported – the PROFIdrive profile with DSC for positioning mode and the PROFIsafe profile for safety-related communication. Functions, such as Shared Device, ring redundancy and PROFInergy, are also possible.

Everything from one source: Through the use of Motion Control functionalities in the controller, the combination of converter and SIMATIC S7 automation system or a SIMOTION controller allows ideally harmonized engineering. As a result, commissioning times are shortened.

Via technology objects and Motion Control blocks of the higher-level controller, there are many possibilities of motion, such as continuous operation, positioning and synchronous operation, and coordinated motion of multiple axes via cyclic cams or interpolation.

Siemens offers tested SIMATIC PLC/HMI application examples for connection of the servo drive system to a SIMATIC controller: www.siemens.com/sinamics-applications

Further information on the SIMATIC S7-1500, SIMATIC S7-1500 T-CPU and SIMATIC ET 200SP Open Controller is available in the ST 70 Catalog and on the Internet under www.siemens.com/simatic-s7-1500

¹⁾ Available in SINAMICS V5.1 SP1 and higher. The Extended Functions require a Safety license as well as Safety-capable SIMOTICS S-1FK2 servomotors (14th data position of the Article No. equal to **S** or **M**).

System overview

SINAMICS S210 servo drive system

Overview (continued)

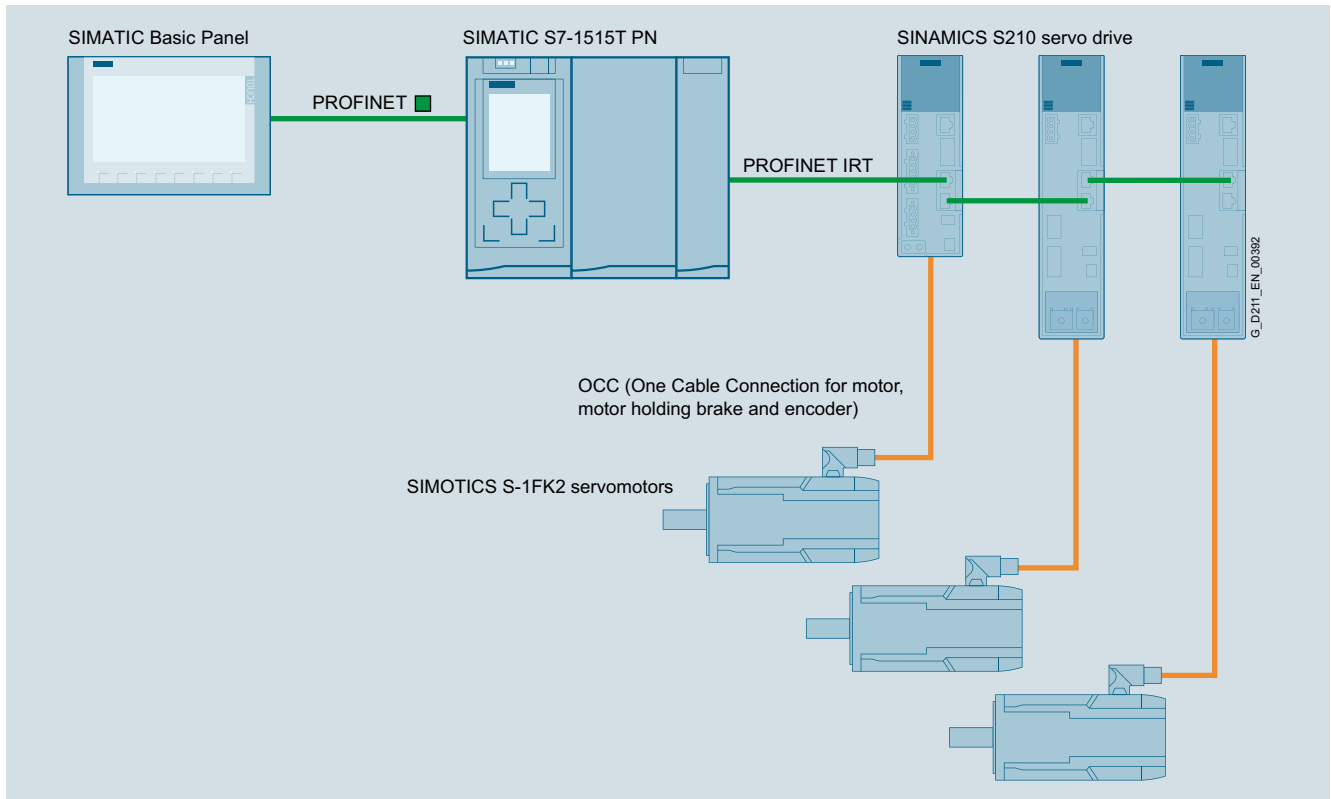

Example: Communication via PROFINET

Ruggedness

The SINAMICS S210 is equipped as standard with varnished or partially varnished modules. The painting on the modules protects the sensitive SMD components against corrosive gases, chemically active dust and moisture.

Can be used worldwide

In addition to the usual approvals, the SINAMICS S210 drive system also has UL approval for the North American market. This means that the drive system, comprising SINAMICS S210 and SIMOTICS S-1FK2, including the One Cable Connection (OCC), can be used worldwide.

More information

A **Quick Installation Guide** is supplied in hard copy form in English with every SINAMICS S210. Further documentation, such as the operating instructions, is available free on the Internet at:

www.siemens.com/sinamics-s210/documentation

Detailed information on the SINAMICS S210 drive system, including the latest technical documentation (brochures, tutorials, dimensional drawings, certificates, manuals and operating instructions), is available on the Internet at:

www.siemens.com/sinamics-s210

and is also available via the Drive Technology Configurator (DT Configurator) on the Internet.

The DT Configurator can be found in the Siemens Industry Mall at the following address:

www.siemens.com/dt-configurator

Overview (continued)

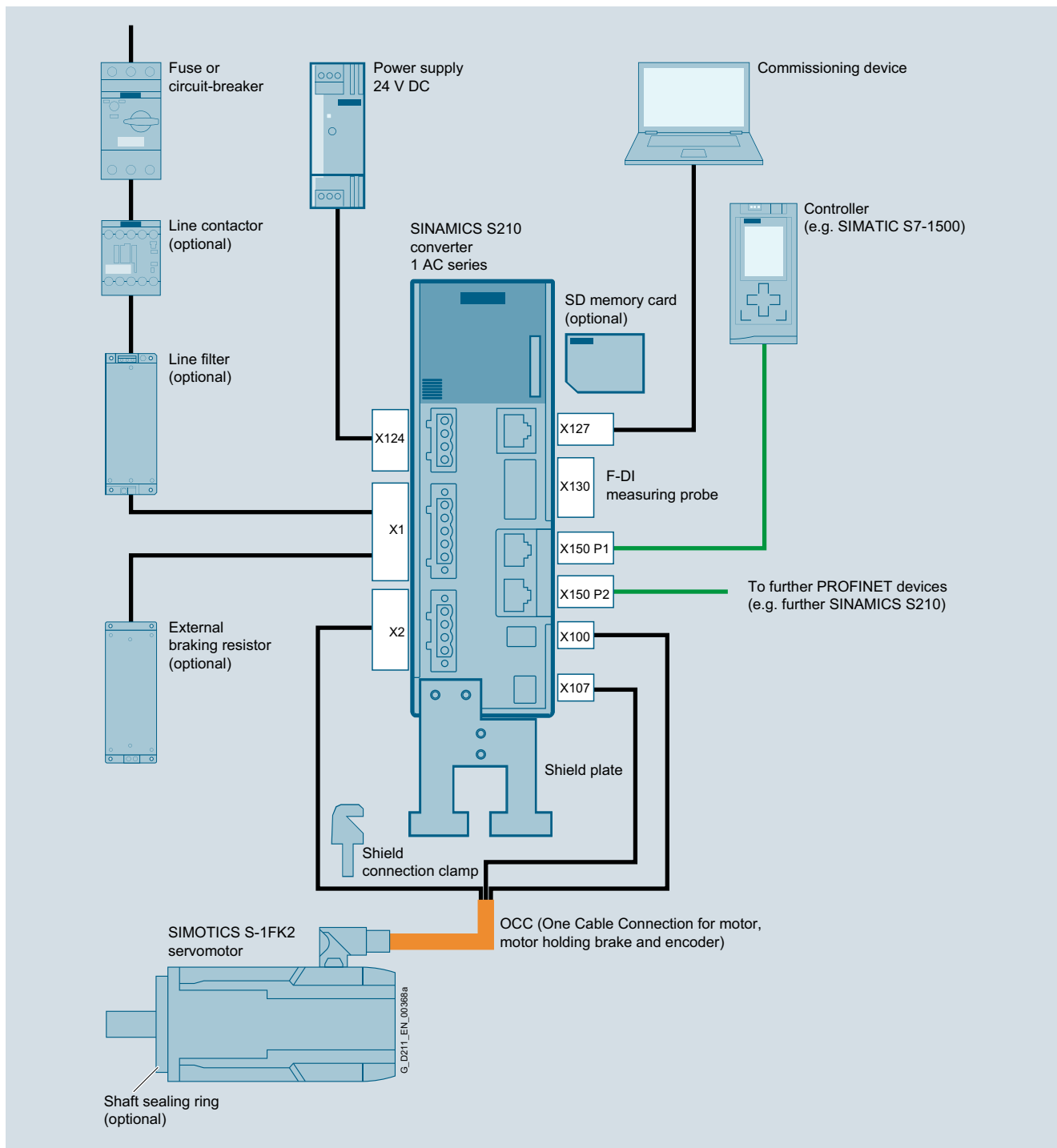

Example for the 1 AC series

System overview

SINAMICS S210 servo drive system

1

Overview (continued)

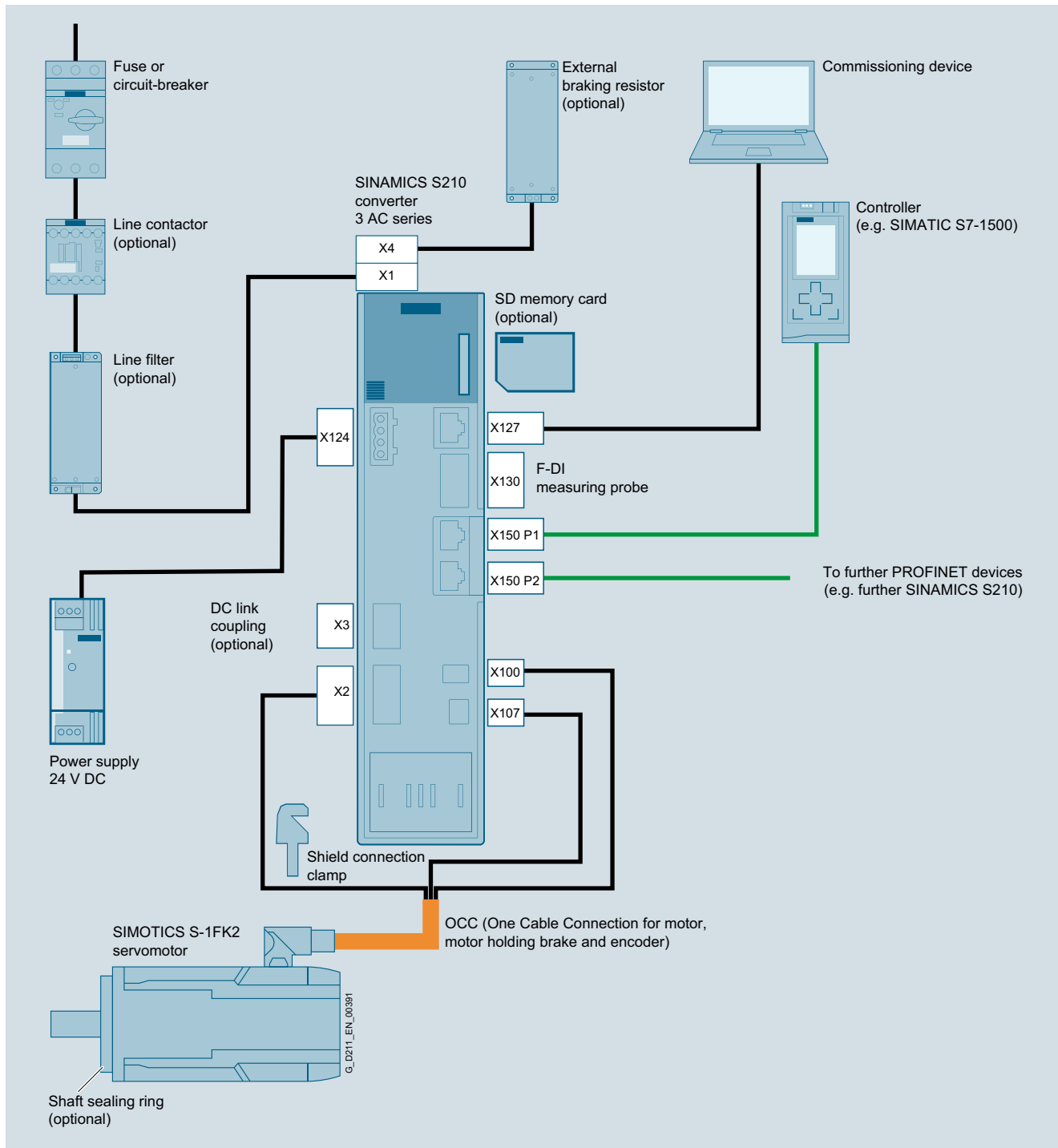

Example for the 3 AC series

Order overview

SINAMICS S210 drive system for line connection 200 ... 240 V 1 AC

SIMOTICS S-1FK2 servomotor							SINAMICS S210 servo converter (1 AC series) Supply voltage 200 ... 240 V 1 AC			MOTION-CONNECT motor connection cable
Static torque	Maximum torque	Maximum speed	Rated power	Rated torque	Rotor moment of inertia	Article No.	Max. motor power	Frame size	Article No.	Article No.
M_0	M_{max}	n_{max}	P_{rated}	M_{rated}	J_{Mot}		P_{rated}			
Nm (lb _f -ft)	Nm (lb _f -ft)	rpm	kW (hp)	Nm (lb _f -ft)	kg cm ² (lb _f -in ²)		kW			
High Dynamic for highly dynamic applications							SINAMICS S210 servo converter			One Cable Connection
Shaft height 20 – rated speed n_{rated} 3000 rpm										
0.16 (0.12)	0.56 (0.41)	8000	0.05 (0.07)	0.16 (0.12)	0.025 (0.009)	1FK2102-0AG-...-...A0	0.1	FSA	6SL3210-5HB10-1UF0	6FX...002-8QN04-1...
0.32 (0.24)	1.11 (0.82)	8000	0.1 (0.13)	0.32 (0.24)	0.036 (0.012)	1FK2102-1AG-...-...A0	0.1	FSA	6SL3210-5HB10-1UF0	6FX...002-8QN04-1...
Shaft height 30 – rated speed n_{rated} 3000 rpm										
0.64 (0.47)	1.95 (1.44)	8000	0.2 (0.27)	0.64 (0.47)	0.093 (0.032)	1FK2103-2AG-...-...A0	0.2	FSA	6SL3210-5HB10-2UF0	6FX...002-8QN04-1...
1.27 (0.94)	4.05 (2.99)	7300	0.4 (0.54)	1.27 (0.94)	0.139 (0.047)	1FK2103-4AG-...-...A0	0.4	FSB	6SL3210-5HB10-4UF0	6FX...002-8QN04-1...
Shaft height 40 – rated speed n_{rated} 3000 rpm										
1.27 (0.94)	3.85 (2.84)	7500	0.4 (0.54)	1.27 (0.94)	0.35 (0.120)	1FK2104-4AK-...-...A0	0.4	FSB	6SL3210-5HB10-4UF0	6FX...002-8QN08-1...
2.4 (1.77)	7.6 (5.61)	7100	0.75 (1.01)	2.4 (1.77)	0.56 (0.191)	1FK2104-5AK-...-...A0	0.75	FSC	6SL3210-5HB10-8UF0	6FX...002-8QN08-1...
Compact for high precision applications							SINAMICS S210 servo converter			One Cable Connection
Shaft height 30 – rated speed n_{rated} 3000 rpm										
0.64 (0.47)	1.85 (1.36)	8000	0.2 (0.27)	0.64 (0.47)	0.2 (0.068)	1FK2203-2AG-...-...A0	0.2	FSA	6SL3210-5HB10-2UF0	6FX...002-8QN04-1...
1.27 (0.94)	3.75 (2.77)	7800	0.4 (0.54)	1.27 (0.94)	0.35 (0.120)	1FK2203-4AG-...-...A0	0.4	FSB	6SL3210-5HB10-4UF0	6FX...002-8QN04-1...
Shaft height 40 – rated speed n_{rated} 3000 rpm										
2.4 (1.77)	7.1 (5.24)	7500	0.75 (1.01)	2.4 (1.77)	1.23 (0.420)	1FK2204-5AK-...-...A0	0.75	FSC	6SL3210-5HB10-8UF0	6FX...002-8QN08-1...

Article No. supplements

Holding brake	
Without brake	0
With brake	1
Degree of protection	
IP64 (without shaft sealing ring)	0
IP65 (with shaft sealing ring)	1
Shaft extension, feather key	
Plain shaft	0
Shaft with feather key	1
Plain shaft $\varnothing 11 \times 23$ mm (0.43 x 0.91 in) (only for 1FK2 . 03 and IP64)	0 2
Encoder	
AS22DQC (absolute encoder 22-bit singleturn)	S
AM22DQC (absolute encoder 22-bit + 12-bit multiturn)	M

Pre-assembled MOTION-CONNECT cable	
MOTION-CONNECT 500	5
MOTION-CONNECT 800PLUS	8
Length code (max. 50 m (164 ft))	
0 m (0 ft)	A
10 m (32.8 ft)	B
20 m (65.6 ft)	C
30 m (98.4 ft)	D
40 m (131 ft)	E
50 m (164 ft)	F
0 m (0 ft)	A
1 m (3.28 ft)	B
2 m (6.56 ft)	C
3 m (9.84 ft)	D
4 m (13.1 ft)	E
5 m (16.4 ft)	F
6 m (19.7 ft)	G
7 m (23.0 ft)	H
8 m (26.2 ft)	J
9 m (29.5 ft)	K
0 m (0 ft)	0
0.1 m (0.33 ft)	1
0.2 m (0.66 ft)	2
0.3 m (0.98 ft)	3
0.4 m (1.31 ft)	4
0.5 m (1.64 ft)	5
0.6 m (1.97 ft)	6
0.7 m (2.30 ft)	7
0.8 m (2.62 ft)	8

The SIMOTICS S-1FK2 servomotors are available for 230 V 1 AC networks with a torque range from 0.16 Nm to 2.4 Nm with shaft heights from 20 to 40.

Order overview (continued)

SINAMICS S210 drive system for line connection 380 ... 480 V 3 AC

SIMOTICS S-1FK2 servomotor							SINAMICS S210 servo converter (3 AC series) Supply voltage 380 ... 480 V 3 AC			MOTION-CONNECT motor connection cable
Static torque	Maximum torque	Maximum speed	Rated power	Rated torque	Rotor moment of inertia	Article No.	Max. motor power	Frame size	Article No.	Article No.
M_0	M_{max}	n_{max}	P_{rated}	M_{rated}	J_{Mot}		P_{rated}			
Nm (lb _f -ft)	Nm (lb _f -ft)	rpm	kW (hp)	Nm (lb _f -ft)	kg cm ² (lb _f -in ²)		kW			
High Dynamic for highly dynamic applications							SINAMICS S210 servo converter			One Cable Connection
Shaft height 40 – rated speed n_{rated} 3000 rpm										
1.3 (0.96)	3.8 (2.80)	7200	0.4 (0.54)	1.27 (0.94)	0.35 (0.120)	1FK2104-4AF-...-A0	0.4	FSA	6SL3210-5HE10-4UF0	6FX002-8QN08-1...
2.4 (1.77)	7.5 (5.53)	6700	0.75 (1.01)	2.4 (1.77)	0.56 (0.191)	1FK2104-5AF-...-A0	0.75	FSA	6SL3210-5HE10-8UF0	6FX002-8QN08-1...
3.2 (2.36)	10 (7.38)	7200	1 (1.34)	3.2 (2.36)	0.76 (0.26)	1FK2104-6AF-...-A0	1	FSA	6SL3210-5HE11-0UF0	6FX002-8QN08-1...
Compact for high precision applications							SINAMICS S210 servo converter			One Cable Connection
Shaft height 40 – rated speed n_{rated} 3000 rpm										
2.4 (1.77)	7.1 (5.24)	7500	0.75 (1.01)	2.4 (1.77)	1.23 (0.420)	1FK2204-5AF-...-A0	0.75	FSA	6SL3210-5HE10-8UF0	6FX002-8QN08-1...
3.2 (2.36)	9.5 (7.01)	7600	1 (1.34)	3.2 (2.36)	1.61 (0.550)	1FK2204-6AF-...-A0	1	FSA	6SL3210-5HE11-0UF0	6FX002-8QN08-1...

Article No. supplements

Holding brake	
Without brake	0
With brake	1
Degree of protection	
IP64 (without shaft sealing ring)	0
IP65 (with shaft sealing ring)	1
Shaft extension, feather key	
Plain shaft	0
Shaft with feather key	1
Plain shaft $\varnothing 11 \times 23$ mm (0.43 \times 0.91 in) (only for 1FK2 . 03 and IP64)	0 2
Encoder	
AS22DQC (absolute encoder 22-bit singleturn)	S
AM22DQC (absolute encoder 22-bit + 12-bit multiturn)	M

Pre-assembled MOTION-CONNECT cable	
MOTION-CONNECT 500	5
MOTION-CONNECT 800PLUS	8

Length code (max. 50 m (164 ft))

0 m (0 ft)	A
10 m (32.8 ft)	B
20 m (65.6 ft)	C
30 m (98.4 ft)	D
40 m (131 ft)	E
50 m (164 ft)	F
0 m (0 ft)	A
1 m (3.28 ft)	B
2 m (6.56 ft)	C
3 m (9.84 ft)	D
4 m (13.1 ft)	E
5 m (16.4 ft)	F
6 m (19.7 ft)	G
7 m (23.0 ft)	H
8 m (26.2 ft)	J
9 m (29.5 ft)	K
0 m (0 ft)	0
0.1 m (0.33 ft)	1
0.2 m (0.66 ft)	2
0.3 m (0.98 ft)	3
0.4 m (1.31 ft)	4
0.5 m (1.64 ft)	5
0.6 m (1.97 ft)	6
0.7 m (2.30 ft)	7
0.8 m (2.62 ft)	8

The SIMOTICS S-1FK2 servomotors are available for 400 V 3 AC networks with a torque range from 1.27 Nm to 3.2 Nm with shaft height 40.

Additional SIMOTICS S-1FK2 servomotors with shaft heights from 48 to 100 and suitable SINAMICS S210 servo converters plus MOTION-CONNECT connection systems will be available soon.

System overview

SINAMICS S210 servo drive system

1

Order overview (continued)

Accessories for SINAMICS S210 servo converters

Description	Article No.
SINAMICS SD card (optional) 512 MB The parameter assignment, firmware and licenses for a converter can be stored on this memory card. Firmware V5.2 or higher is required for the 3 AC series. <ul style="list-style-type: none"> • Empty • With firmware V5.1 • With firmware V5.1 SP1 • With firmware V5.1 SP1 and Safety license (Extended Functions) • With firmware V5.2 • With firmware V5.2 and Safety license (Extended Functions) 	6SL3054-4AG00-2AA0 6SL3054-4FB00-2BA0 6SL3054-4FB10-2BA0 6SL3054-4FB10-2BA0-Z F01 6SL3054-4FC00-2BA0 6SL3054-4FC00-2BA0-Z F01
Safety license (Extended Functions) ¹⁾	6SL3074-0AA10-0AA0
PROFINET patch cable For the networking of concatenated converters <ul style="list-style-type: none"> • 0.3 m • 0.5 m 	6XV1870-3QE30 6XV1870-3QE50
Only for the 1 AC series	
Line filter ²⁾ European standard EN 61008-3 Category C2 can also be achieved for cable lengths up to 25 m (82 ft) with this line filter. Category C3 is reached with cable lengths up to 50 m (164 ft).	6SL3203-0BB21-8VA0
Only for the 3 AC series	
Connector set AC and DC link For coupling the DC link and the line infeed <ul style="list-style-type: none"> • 1 AC bus connector • 1 DC link connector • 2 cover caps Wiring is performed with conventional 16 mm ² cable (not included in scope of delivery) ³⁾	6SL3260-2DC00-0AA0
Connector set AC link individual For coupling the line infeed <ul style="list-style-type: none"> • 1 AC bus connector • 1 cover cap This connector replaces the push-in connector included in the scope of delivery of the converter. Wiring is performed with conventional 16 mm ² cable (not included in scope of delivery) ³⁾	6SL3260-2DC10-0AA0

Accessories for SIMOTICS S-1FK2 servomotors

Description	For motor	Article No.
Shaft sealing ring (optional) To achieve degree of protection IP65 for retrofitting or as spare part	1FK2 . 02	1FK2902-0GC00
	1FK2 . 03	1FK2903-0GC00
	1FK2 . 04	1FK2904-0GC00

¹⁾ Extended function for an existing memory card (firmware V5.1 SP1 or higher). The memory card is not included in the scope of delivery. The Safety license can also be ordered together with a memory card (see above).

²⁾ The line filter does not have UL approval.

³⁾ Permissible cables:
 - 16 mm², class 5 (finely stranded, PVC-insulated) H07V-K according to EN 50525-2-31
 - External diameter 6.7 mm to 8.1 mm

Permissible cables (UL approval):
 - 6 AWG, copper cable with PVC insulation, with or without nylon jacket, 19 strands
 - Types: MTW, THHW, THW, THW-2, THHN, THWN-2, TW, TWN
 - CSA types: TW, TWU, TWN75, TW75, TWU75, T90, no compressed conductors

Order overview (continued)

Accessories for MOTION-CONNECT connection systems

OCC extension cables

Description	Cross-section mm ²	For motor	OCC extension cable (for length code, see SINAMICS S210 drive system table) Article No.
Pre-assembled OCC extension cable MOTION-CONNECT 500 incl. shield connection clamp	0.38	1FK2102, 1FK2 . 03	6FX5002-8QE04-1 ■■■■
	0.75	1FK2 . 04, 1FK2 . 05	6FX5002-8QE08-1 ■■■■
	1.5	1FK2 . 06, 1FK2 . 08, 1FK2 . 10	6FX5002-8QE11-1 ■■■■
	2.5 ²⁾	1FK2 . 06, 1FK2 . 08, 1FK2 . 10	6FX5002-8QE21-1 ■■■■
Pre-assembled OCC extension cable MOTION-CONNECT 800PLUS incl. shield connection clamp	0.38	1FK2102, 1FK2 . 03	6FX8002-8QE04-1 ■■■■
	0.75	1FK2 . 04, 1FK2 . 05	6FX8002-8QE08-1 ■■■■
	1.5	1FK2 . 06, 1FK2 . 08, 1FK2 . 10	6FX8002-8QE11-1 ■■■■
	2.5 ²⁾	1FK2 . 06, 1FK2 . 08, 1FK2 . 10	6FX8002-8QE21-1 ■■■■
Pre-assembled OCC extension cable MOTION-CONNECT 500 With connector supplied on the converter side ¹⁾ incl. shield connection clamp	0.38	1FK2102, 1FK2 . 03	6FX5012-8QE04-1 ■■■■
	0.75	1FK2 . 04, 1FK2 . 05	6FX5012-8QE08-1 ■■■■
	1.5	1FK2 . 06, 1FK2 . 08, 1FK2 . 10	6FX5012-8QE11-1 ■■■■
	2.5 ²⁾	1FK2 . 06, 1FK2 . 08, 1FK2 . 10	6FX5012-8QE21-1 ■■■■
Pre-assembled OCC extension cable MOTION-CONNECT 800PLUS With connector supplied on the converter side ¹⁾ incl. shield connection clamp	0.38	1FK2102, 1FK2 . 03	6FX8012-8QE04-1 ■■■■
	0.75	1FK2 . 04, 1FK2 . 05	6FX8012-8QE08-1 ■■■■
	1.5	1FK2 . 06, 1FK2 . 08, 1FK2 . 10	6FX8012-8QE11-1 ■■■■
	2.5 ²⁾	1FK2 . 06, 1FK2 . 08, 1FK2 . 10	6FX8012-8QE21-1 ■■■■

OCC components for self assembly

Description	Cross-section mm ²	For motor	OCC component (for length code, see SINAMICS S210 drive system table) Article No.
Sold by the meter OCC line MOTION-CONNECT 500¹⁾	0.38	1FK2102, 1FK2 . 03	6FX5008-1BE04-1 ■■■■
	0.75	1FK2 . 04, 1FK2 . 05	6FX5008-1BE08-1 ■■■■
	1.5	1FK2 . 06, 1FK2 . 08, 1FK2 . 10	6FX5008-1BE11-1 ■■■■
	2.5 ²⁾	1FK2 . 06, 1FK2 . 08, 1FK2 . 10	6FX5008-1BE21-1 ■■■■

OCC components for self assembly (continued)

Description	Cross-section mm ²	For motor	OCC component (for length code, see SINAMICS S210 drive system table) Article No.
Sold by the meter OCC line MOTION-CONNECT 800PLUS¹⁾	0.38	1FK2102, 1FK2 . 03	6FX8008-1BE04-1 ■■■■
	0.75	1FK2 . 04, 1FK2 . 05	6FX8008-1BE08-1 ■■■■
	1.5	1FK2 . 06, 1FK2 . 08, 1FK2 . 10	6FX8008-1BE11-1 ■■■■
	2.5 ²⁾	1FK2 . 06, 1FK2 . 08, 1FK2 . 10	6FX8008-1BE21-1 ■■■■
Motor-side SPEED-CONNECT connector¹⁾ • M12 • M17 • M23	0.38	1FK2102, 1FK2 . 03	6FX2003-0LU64
	0.75	1FK2 . 04, 1FK2 . 05	6FX2003-0LU54
	1.5 and 2.5	1FK2 . 06, 1FK2 . 08, 1FK2 . 10	6FX2003-0LU34
	SPEED-CONNECT connector with external thread for extension cable¹⁾ • M12 • M17 • M23		
0.38	1FK2102, 1FK2 . 03	6FX2003-0LA64	
0.75	1FK2 . 04, 1FK2 . 05	6FX2003-0LA54	
1.5 and 2.5	1FK2 . 06, 1FK2 . 08, 1FK2 . 10	6FX2003-0LA34	
Converter-side Siemens IX signal connector¹⁾	–	–	6FX2003-0DE01
Shield clamp (Packing unit: 10 items) • For pre-assembled cables with M12 and M17 and connectors • For pre-assembled cables with M23 connectors ¹⁾	0.38 and 0.75	–	6FX2003-7EX10
	1.5 and 2.5	–	6FX2003-7EX11

Control cabinet bushings

Description	For motor	Article No.
Mounting flange	1FK2102, 1FK2 . 03	6FX2003-7JX00
	1FK2 . 04, 1FK2 . 05	6FX2003-7HX00
	1FK2 . 06, 1FK2 . 08, 1FK2 . 10	Available soon

Recommended SIMATIC S7 controller

Further information about SIMATIC S7-1500 and SIMATIC S7-1500 T-CPU controllers is available in Catalog ST 70 and on the Internet at www.siemens.com/simatic-s7-1500

¹⁾ Available soon.

²⁾ For increased requirement regarding routing type and ambient temperature. See tables in the section MOTION-CONNECT connection systems > More information > Current carrying capacity and derating factors.

System overview

1

SINAMICS S210 starter kit

Overview



The SINAMICS S210 starter kit with Extended Safety with Article No. 6SL3200-0AE61-0AA0 comprises

- a SINAMICS S210 servo converter, 230 V 1 AC, 400 W (Article No. 6SL3210-5HB10-4UF0)
- a Safety-capable SIMOTICS S-1FK2 servomotor, High Dynamic, shaft height 30, 400 W, without brake, shaft with feather key, with absolute encoder multiturn (Article No. 1FK2103-4AG00-1MA0)
- a corresponding One Cable Connection cable (OCC), 3 m (Article No. 6FX5002-8QN04-1AD0)
- a memory card with firmware V5.2 and Safety license (Extended Functions) (Article No. 6SL3054-4FC00-2BA0-Z F01)

The delivery quantity is limited to three per customer.

The SINAMICS S210 starter kit can be perfectly combined with the SIMATIC S7-1500 starter kit. In this way, Motion Control applications can be quickly and easily implemented.

For more information on SIMATIC S7-1500 starter kits, see: www.siemens.com/s7-1500-starterkits

Selection and ordering data

Description	Article No.
SINAMICS S210 starter kit with Extended Safety With SINAMICS S210 servo converter, Safety-capable SIMOTICS S-1FK2 servomotor (power rating 400 W), OCC cable (3 m (9.84 ft)) and memory card with Safety license (Extended Functions)	NEW 6SL3200-0AE61-0AA0

SINAMICS S210 servo drive



2/2	SINAMICS S210 servo drive
2/2	Overview
2/4	Design
2/5	Function
2/5	Configuration
2/6	Integration
2/8	Selection and ordering data
2/10	Technical specifications
2/13	Dimensional drawings
2/14	Accessories
2/15	Line-side components
2/15	Line filters
2/16	Recommended line-side overcurrent protection devices
2/17	DC link components
2/17	External braking resistors
2/18	Supplementary system components
2/18	Memory cards

Detailed technical information on the SINAMICS S210 servo drive system is available on the Internet at www.siemens.com/sinamics-s210/documentation

In addition, the Drive Technology Configurator (DT Configurator) can be used on the Internet at the following address: www.siemens.com/dt-configurator

SINAMICS S210 servo drive

0.1 kW to 7 kW

SINAMICS S210 servo drive

Overview

SINAMICS S210 – the single-axis servo drive for highly dynamic applications



SINAMICS S210, 1 AC series, frame sizes FSA to FSC



SINAMICS S210, 3 AC series, frame sizes FSA to FSC

The SINAMICS S210 servo converter is designed for connection to SIMOTICS S-1FK2 synchronous servomotors. PROFINET RT/IRT is available for connection to a higher-level control system. That allows, above all, SIMATIC S7 and SIMOTION to be used as controllers.

SINAMICS S210 is optimized for operation with SIMATIC S7-1500 and SIMATIC S7-1500T, which have their own positioning functionality. Therefore no additional basic positioner is integrated into the converter.

The converter works with a servo controller with or without Dynamic Servo Control (DSC) and has a torque setpoint limitation. A wide range of internal protection functions are included to protect the converter.

The status of the converter is indicated by two multi-color LEDs and a 7-segment display. Pending faults can be acknowledged with a button under the front cover.

The converter has a web server, which can be called via the service interface or via PROFINET from a web browser on a PC. Both commissioning and diagnostics can be performed through this. With the web server, the converter can be brought into operation in a few steps. As the motor data from the converter is read from the electronic type plate, they do not need to be parameterized. The PROFIdrive telegram is automatically accepted by the controller; so only the controller parameters have to be adjusted. This is simply done with the One Button Tuning function, which automatically determines the parameters.

In addition to easy commissioning directly via the web server of the converter, engineering is also possible with SINAMICS Startdrive and TIA Portal (as of V15.1). The tool for configuration, commissioning and diagnostics has been optimized with regard to user friendliness and the consistent utilization of the TIA Portal advantages of a shared work environment for PLC, HMI and drives (requires SINAMICS S210 firmware V5.2 or higher).

SIMOTICS S-1FK2 servomotors can be connected and operated via a One Cable Connection (OCC) line. Third-party motors cannot be connected because the converter requires the type plate data of the motor.

No additional components are required for controlling the motor holding brake as all the required components are integrated into the converter. In addition, no special power supply is required because the converter optimally sets the voltage for the brake internally. Thus, in combination with the 1FK2 motors, shortened opening and closing times of the brakes are also possible.

The converter can be operated optionally with a memory card. The card is inserted in the card slot behind the front cover. Firmware and drive parameters can be stored on the memory card, so that the converter can easily be replaced without any other aids. This memory card can also be used to perform series commissioning on multiple drives of identical type.

The card is available as an empty memory card or containing the latest drive firmware version. The memory card also contains the licenses for chargeable functions, such as the safety license for the Extended Safety Functions. To use these functions, a memory card containing the corresponding safety license must be permanently inserted.

If necessary, the converter contains an integrated braking resistor. As a result of the generous dimensioning of the resistor and the DC link capacities, an external braking resistor is only necessary to meet very high requirements.

For the 3 AC series, DC link coupling of up to six devices is possible. Thus, the energy that is generated when braking axes can be used for accelerating other axes. This conserves energy and reduces the amount of heat dissipated via the braking resistors.

The converter also features an integrated line filter. For the 1 AC series, it satisfies category C2 for cable lengths up to 10 m and category C3 for cable lengths up to 25 m. With an optional external line filter, cable lengths of up to 25 m are also possible with category C2 and up to 50 m with category C3. For the 3 AC series, category C3 is achieved for cable lengths up to 25 m. For requirements that go beyond this, an external line filter is required (available soon).

Overview (continued)

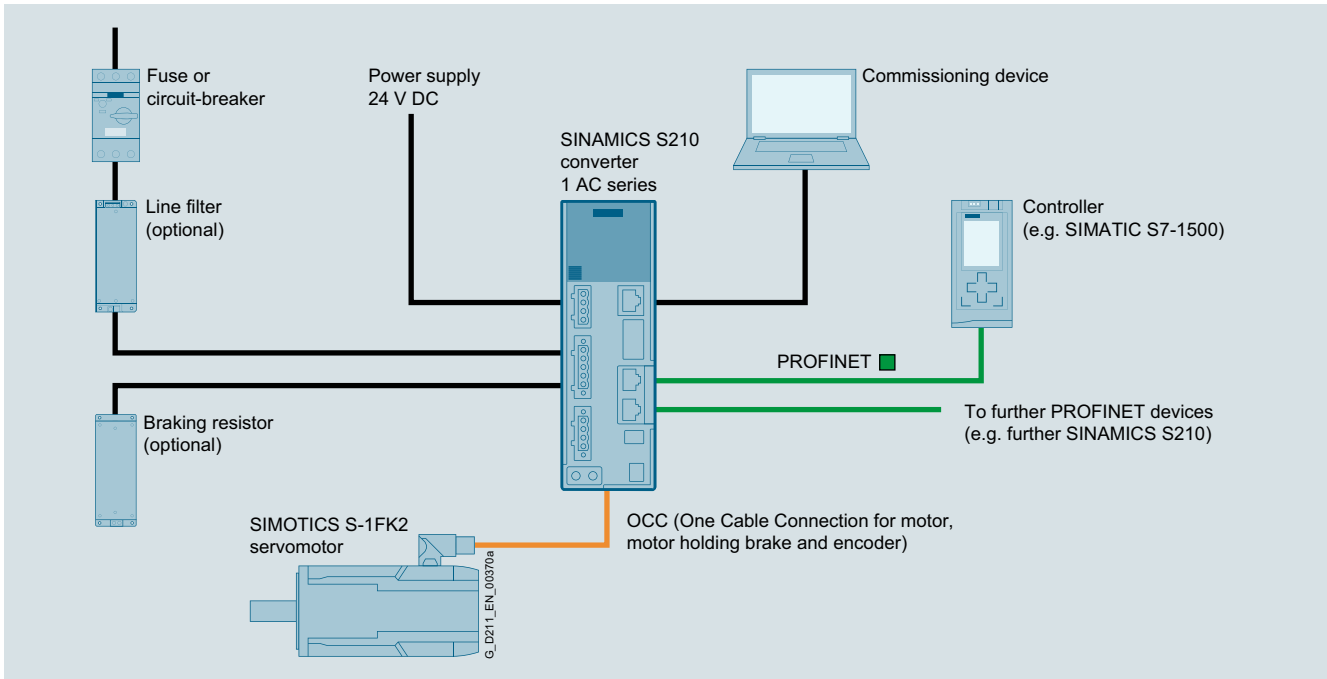

SINAMICS S210 drive system, 1 AC series with optional components

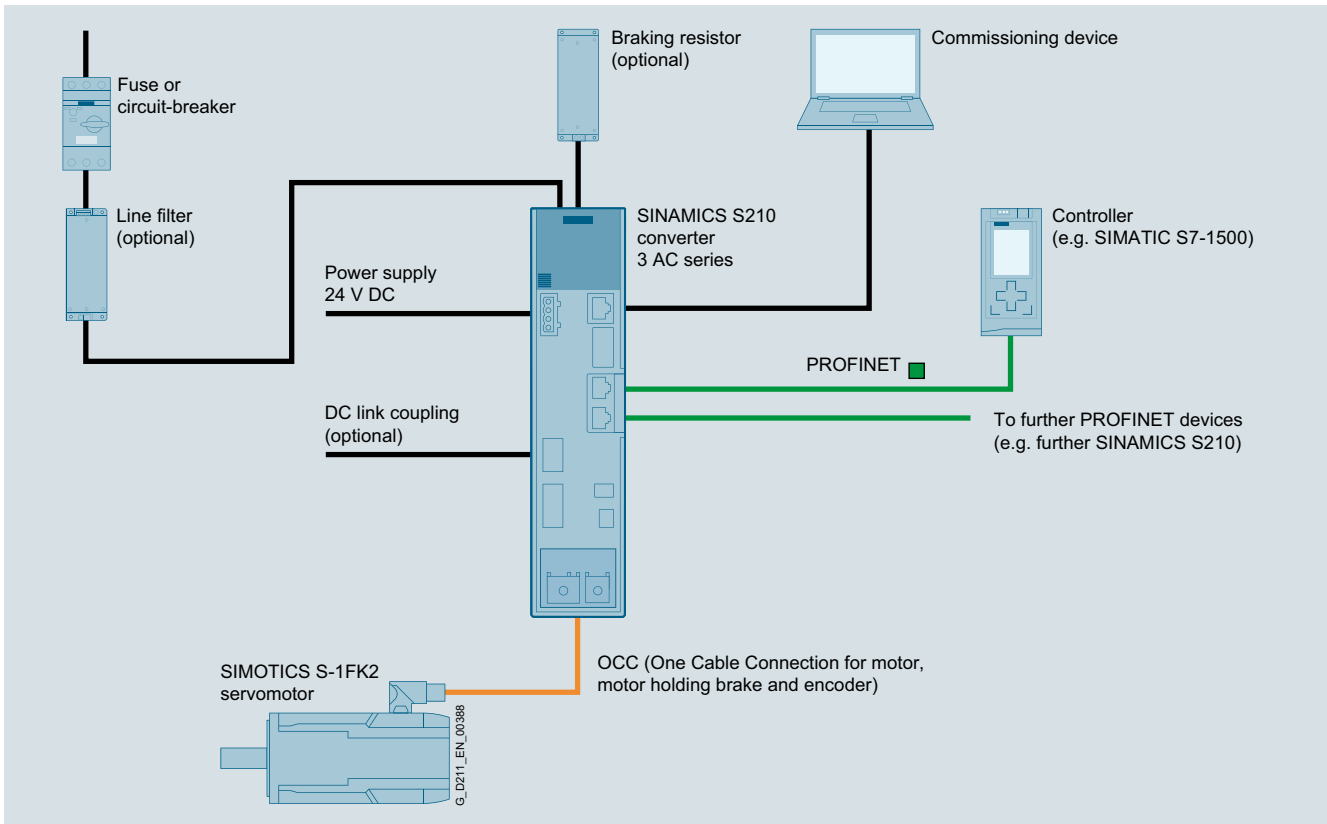

SINAMICS S210 drive system, 3 AC series with optional components

SINAMICS S210 servo drive

0.1 kW to 7 kW

SINAMICS S210 servo drive

Design

The single-axis AC/AC converter contains a power unit and a Control Unit for the powerful communication, open and closed-loop control functions.

The SINAMICS S210 servo converter features the following connections and interfaces as standard:

- Fieldbus interface
 - 1 PROFINET interface with two ports (RJ45 sockets) with PROFIdrive V4 profile
- 1 service interface for Ethernet communications with a service PC
- One Cable Connection (OCC)
 - 1 communications connector for communication with the encoder of the SIMOTICS S-1FK2 motor
 - 1 motor power connector for the power conductors of the SIMOTICS S-1FK2 motor
 - 1 brake connection for the conductors of the motor holding brake of the SIMOTICS S-1FK2 motor
- 1 connection for the electronic power supply via the 24 V DC supply connector (supply can be looped through connectors for several SINAMICS S210)
- 1 connection for the line voltage and an external braking resistor (braking resistor optional, for the 3 AC series via a separate connector)
- 1 connection for the DC link coupling (optional, only for the 3 AC series)
- Digital inputs
 - 1 fail-safe digital input (isolated) for controlling STO and SS1 via terminals
 - 2 high-speed digital inputs for measuring probe or reference marks
 - 1 digital input for monitoring the temperature of an external braking resistor
- 1 slot for a memory card on which the firmware, parameters and licenses can be stored
- 1 display with 3-digit, 7-segment display for indicating faults and two status LEDs
- 1 button for acknowledging errors

DC link coupling (only 3 AC series)

For devices of the 3 AC series, the DC links of up to six converters can be coupled. Thus, energy balancing between the axes is possible and energy produced during braking can be used by other axes for accelerating. This is not only efficient but also reduces the dissipated heat in the control cabinet, because the energy that is produced no longer has to be converted to heat in the braking resistor.

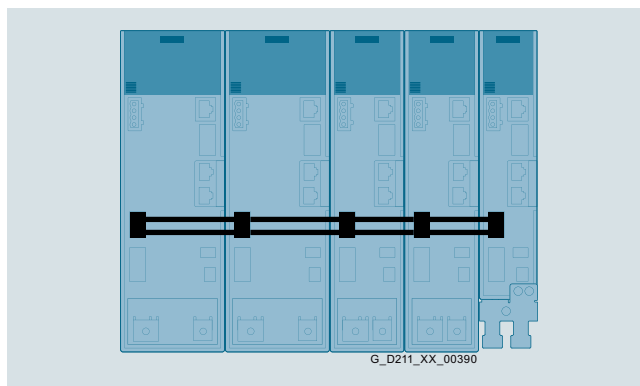

SINAMICS S210, 3 AC series, DC link coupling

Function

Closed-loop control	Servo control with DSC
Control functions	Speed control with encoder Dynamic Servo Control (DSC) Torque setpoint limitation Current controller and current controller adaptation suitably adjusted for SIMOTICS S-1FK2 servomotors One Button Tuning with moment of inertia estimator and reference model Local measuring probe Simple brake control Direction reversal without changing the setpoint channel Travel to fixed stop Vertical axis Speed controller adaptation Thermal monitoring for power unit and servomotor High-performance brake control
Protective functions	Undervoltage DC link voltage Overvoltage DC link voltage Overcurrent power unit Overcurrent motor Overload power unit (I^2t) Short-circuit Ground fault Temperature rise servomotor Temperature rise power unit
Safety Integrated	Safe Torque OFF (STO) Safe Brake Control (SBC) Safe Stop 1 (SS1) Safe Stop 2 (SS2) ¹⁾ Safe Operating Stop (SOS) ¹⁾ Safely-Limited Speed (SLS) ¹⁾ Safe Speed Monitor (SSM) ¹⁾ Safe Direction (SDI) ¹⁾ Safely-Limited Acceleration (SLA) ¹⁾ Safe Brake Test (SBT) diagnostic function ¹⁾
Commissioning	Identification of the SIMOTICS S-1FK2 motors via the electronic type plate Automatic controller optimization

Configuration

The following electronic configuring aids and engineering tools are available for the SINAMICS S210 servo converters:

Drive Technology Configurator (DT Configurator) within the CA 01

The Interactive Catalog CA 01 – the offline Industry Mall of Siemens – contains over 100000 products with approximately 5 million possible drive system product variants. The Drive Technology Configurator (DT Configurator) has been developed to facilitate selection of the correct motor and/or converter from the wide spectrum of drives. It is integrated as a selection tool in the Interactive Catalog CA 01.

Online DT Configurator

In addition, the DT Configurator can be used on the Internet without requiring any installation. The DT Configurator can be found in the Siemens Industry Mall at the following address:
www.siemens.com/dt-configurator

Drive dimensioning of the SINAMICS S210 servo drive system with the TIA Selection Tool

The SINAMICS S210 servo drive system is easily configured with the TIA Selection Tool under the Drive Dimensioning plug-in. It provides support when selecting the hardware and firmware components necessary to implement a drive task. The plug-in encompasses the configuration of the entire drive system and allows the handling of individual drives.

- Intuitive user interface, menu-based operation and help
- Configuration of the SINAMICS S210 servo drive system
- Adjustable traversing cycles and various mechanical systems integrated for single-axis applications
- Interface to the TIA Portal and Industry Mall

The TIA Selection Tool is available for free on the Internet at
www.siemens.com/tia-selection-tool-standalone

Note:

Multi-axis applications and integration into the online version available soon.

SINAMICS web server for SINAMICS S210

The converter can be brought easily and quickly into operation and optimized with the web server. Additional software does not need to be installed as access comes directly from a web browser.

You can find further information about the web server for SINAMICS S210 in the Engineering tools section.

SINAMICS Startdrive commissioning tool (TIA Portal)

SINAMICS Startdrive is a tool for configuring, commissioning, and diagnosing the SINAMICS converter family that is integrated into TIA Portal V15.1.

The SINAMICS Startdrive has been optimized with regard to user friendliness and consistent use of the TIA Portal benefits of a common working environment for PLC, HMI and drives. SINAMICS firmware V5.2 or higher is required for SINAMICS S210.

The SINAMICS Startdrive Advanced license is required for the Safety Integrated acceptance test.

The SINAMICS Startdrive commissioning tool is available free on the Internet at
www.siemens.com/startdrive

¹⁾ Available in firmware V5.1 SP1 and higher. The Extended Functions require a Safety license as well as Safety-capable SIMOTICS S-1FK2 servomotors (14th data position of the Article No. equal to **S** or **M**).

SINAMICS S210 servo drive

0.1 kW to 7 kW

SINAMICS S210 servo drive

Integration

2

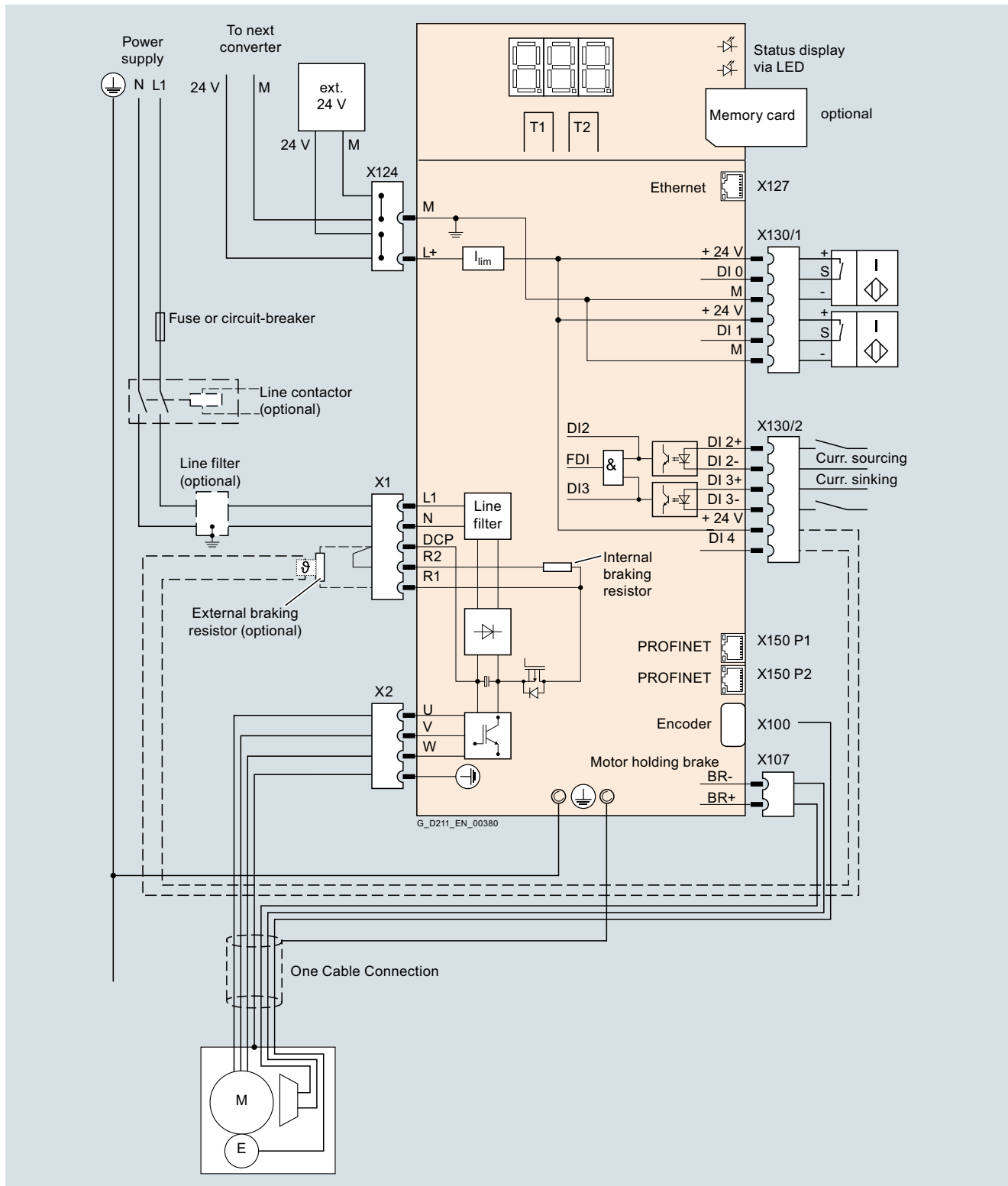

Connection example SINAMICS S210 servo converter, 1 AC series

Integration (continued)

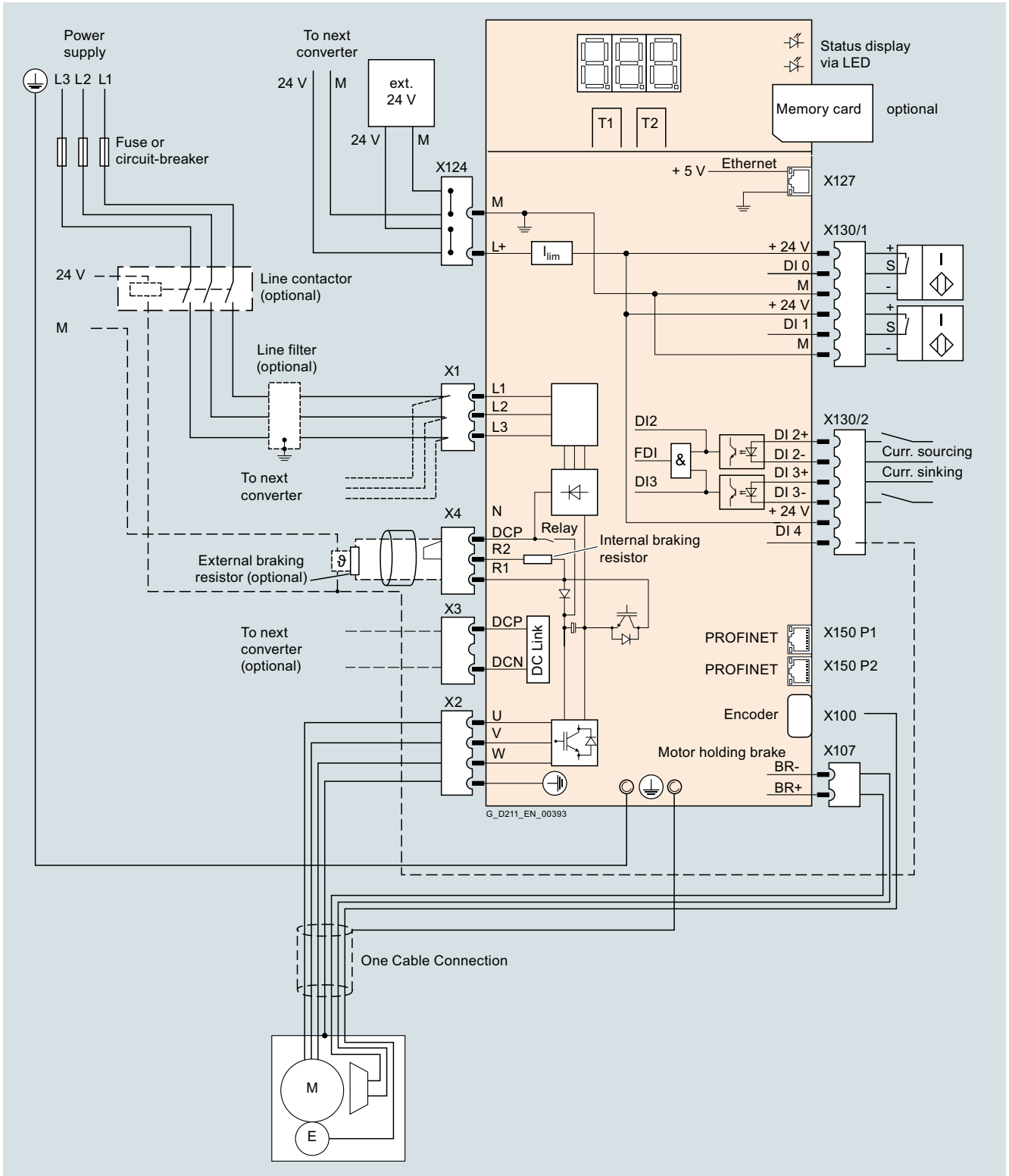

Connection example SINAMICS S210 servo converter, 3 AC series

SINAMICS S210 servo drive



0.1 kW to 7 kW

SINAMICS S210 servo drive

Selection and ordering data

2



Description	Frame size	Article No.
200 ... 240 V 1 AC		
SINAMICS S210 servo converters Incl. shield plate and push-in connector without memory card The shield clamp is included in the scope of delivery of the MOTION-CONNECT cable.		
 <ul style="list-style-type: none"> • 0.1 kW 	FSA	6SL3210-5HB10-1UF0
	FSA	6SL3210-5HB10-2UF0
 <ul style="list-style-type: none"> • 0.4 kW 	FSB	6SL3210-5HB10-4UF0
	FSC	6SL3210-5HB10-8UF0
 <ul style="list-style-type: none"> • 0.75 kW 	FSC	6SL3210-5HB10-8UF0





Description	Frame size	Article No.
200 ... 480 V 3 AC		
SINAMICS S210 servo converters NEW Incl. shield plate and push-in connector without memory card The shield clamp is included in the scope of delivery of the MOTION-CONNECT cable.		
 <ul style="list-style-type: none"> • 0.4 kW • 0.75 kW • 1 kW 	FSA	6SL3210-5HE10-4UF0
	FSA	6SL3210-5HE10-8UF0
	FSA	6SL3210-5HE11-0UF0
 <ul style="list-style-type: none"> • 1.5 kW • 2 kW 	FSB ¹⁾	6SL3210-5HE11-5UF0
	FSB ¹⁾	6SL3210-5HE12-0UF0
 <ul style="list-style-type: none"> • 3.5 kW • 5 kW • 7 kW 	FSC ¹⁾	6SL3210-5HE13-5UF0
	FSC ¹⁾	6SL3210-5HE15-0UF0
	FSC ¹⁾	6SL3210-5HE17-0UF0

¹⁾ Available soon.

Selection and ordering data (continued)

Accessories

Description	Article No.
 <p>SINAMICS SD card (optional) 512 MB</p> <p>The parameter assignment, firmware and licenses for a converter can be stored on this memory card.</p> <p>Firmware V5.2 or higher is required for the 3 AC series.</p> <ul style="list-style-type: none"> • Empty • With firmware V5.1 • With firmware V5.1 SP1 • With firmware V5.1 SP1 and Safety license (Extended Functions) • With firmware V5.2 NEW • With firmware V5.2 and Safety license (Extended Functions) NEW 	<p>6SL3054-4AG00-2AA0</p> <p>6SL3054-4FB00-2BA0</p> <p>6SL3054-4FB10-2BA0</p> <p>6SL3054-4FB10-2BA0-Z F01</p> <p>6SL3054-4FC00-2BA0</p> <p>6SL3054-4FC00-2BA0-Z F01</p>
<p>Safety license (Extended Functions) ¹⁾</p>	6SL3074-0AA10-0AA0
 <p>PROFINET patch cable</p> <p>For the networking of concatenated converters</p> <p>Industrial Ethernet TP cord, CAT 6 A, twisted pair line 4 × 2 cores, pre-assembled with two RJ45 connectors</p> <ul style="list-style-type: none"> • 0.3 m (0.98 ft) • 0.5 m (1.64 ft) 	<p>6XV1870-3QE30</p> <p>6XV1870-3QE50</p>

Description	Article No.
Only for the 1 AC series	
 <p>Line filter ²⁾</p> <p>European standard EN 61008-3 Category C2 can also be achieved for cable lengths up to 25 m (82 ft) with this line filter. Category C3 is reached with cable lengths up to 50 m (164 ft).</p>	6SL3203-0BB21-8VA0
 <p>Replacement connector set</p> <p>For frame sizes FSA, FSB and FSC</p> <p>With a connector set, as in the scope of delivery, and two shield plates</p>	6SL3260-2DB00-0AA0
Only for the 3 AC series	
 <p>Replacement connector set NEW</p> <p>For frame sizes FSA, FSB and FSC</p> <p>With a connector set, as in the scope of delivery, and one shield plate (for FSA)</p>	6SL3260-2DB10-0AA0
 <p>Connector set AC and DC link NEW</p> <p>For coupling the DC link and the line infeed</p> <ul style="list-style-type: none"> • 1 AC bus connector • 1 DC link connector • 2 cover caps <p>Wiring is performed with conventional 16 mm² cable (not included in scope of delivery) ³⁾</p>	6SL3260-2DC00-0AA0
 <p>Connector set AC link individual NEW</p> <p>For coupling the line infeed</p> <ul style="list-style-type: none"> • 1 AC bus connector • 1 cover cap <p>This connector replaces the push-in connector included in the scope of delivery of the converter. Wiring is performed with conventional 16 mm² cable (not included in scope of delivery) ³⁾</p>	6SL3260-2DC10-0AA0
<p>Replacement fan NEW</p> <p>Incl. support</p> <ul style="list-style-type: none"> • Frame size FSA • Frame size FSB ⁴⁾ • Frame size FSC ⁴⁾ 	<p>6SL3260-0AA00-0AA0</p> <p>6SL3260-0AB00-0AA0</p> <p>6SL3260-0AC00-0AA0</p>

¹⁾ Extended function for an existing memory card (firmware V5.1 SP1 or higher). The memory card is not included in the scope of delivery. The Safety license can also be ordered together with a memory card (see above).

²⁾ The line filter does not have UL approval.

³⁾ Permissible cables:
 - 16 mm², class 5 (finely stranded, PVC-insulated) H07V-K according to EN 50525-2-31
 - External diameter 6.7 mm to 8.1 mm

Permissible cables (UL approval):
 - 6 AWG, copper cable with PVC insulation, with or without nylon jacket, 19 strands
 - Types: MTW, THHW, THW, THW-2, THHN, THWN-2, TW, TWN
 - CSA types: TW, TWU, TWN75, TW75, TWU75, T90, no compressed conductors

⁴⁾ Available soon.

SINAMICS S210 servo drive

0.1 kW to 7 kW

SINAMICS S210 servo drive**Technical specifications**

Unless explicitly specified otherwise, the following technical specifications are valid for all SINAMICS S210 servo converters.

General technical specifications**Mechanical specifications****Vibratory load**

- Transport ¹⁾ acc. to IEC/EN 60721-3-2
- Operation acc. to IEC/EN 60721-3-3
 - Test values according to IEC/EN 60068-2-6

Class 2M3
Class 3M2
Test Fc (sinusoidal)

- 9 ... 18 Hz: 1.5 mm deflection amplitude
- 18 Hz ... 200 Hz: 2 × g acceleration amplitude
- 10 frequency cycles per axis

Shock load

- Transport ¹⁾ acc. to IEC/EN 60721-3-2
- Operation acc. to IEC/EN 60721-3-3
 - Test values according to IEC/EN 60068-2-27

Class 2M3
Class 3M2
Test Ea (semisinusoidal)

- 5 × g peak acceleration
- 30 ms duration
- 3 shocks in all three axes in both directions

Environmental conditions**Protection class**

According to IEC/EN 61800-5-1

Class I (with protective bonding circuit) and class III (PELV or SELV)

Degree of protection

According to IEC/EN 60529

IP20
Mounting in control cabinet necessary**Permissible ambient temperature (air) in operation**

0 ... 50 °C (32 ... 122 °F)

Installation altitude

Up to max. 4000 m (13123 ft)

- Up to 1000 m (3281 ft) above sea level without derating
- As from 1000 m (3281 ft) derating 10 % of current or 5 K per 1000 m (3281 ft)
- Isolation transformer required as from 2000 m (6562 ft)

Climatic environmental conditions

- Storage ²⁾ acc. to IEC/EN 60721-3-1
- Transport ¹⁾ acc. to IEC/EN 60721-3-2
- Operation acc. to IEC/EN 60721-3-3

Class 1K4
-25 ... +55 °C (-13 ... +131 °F)

Class 2K4
-40 ... +70 °C (-40 ... +158 °F)
Max. air humidity: 95 % at 40 °C (104 °F)
Better than class 3K3

0 ... 50 °C (32 ... 122 °F)
Relative air humidity: 5 ... 95 %
Condensation, splashwater, and ice formation not permitted (IEC/EN 60204, Part 1)

Environmental class/harmful chemical substances

- Storage ²⁾ acc. to IEC/EN 60721-3-1
- Transport ¹⁾ acc. to IEC/EN 60721-3-2
- Operation acc. to IEC/EN 60721-3-3

Class 1C2
Class 2C2
Class 3C2

Organic/biological influences

- Storage ²⁾ acc. to IEC/EN 60721-3-1
- Transport ¹⁾ acc. to IEC/EN 60721-3-2
- Operation acc. to IEC/EN 60721-3-3

Class 1B2
Class 2B2
Class 3B2

Degree of pollution

According to IEC/EN 61800-5-1

2

Standards**Certificates of suitability**

CE, cULus (UL File No. E355661 for 1 AC series, E192450 for 3 AC series), RCM, EAC, KC (only for 1 AC series, available soon for 3 AC series)

Functional safety

- SIL 2 according to IEC 61508 parts 1 to 3 (2010) and IEC 61800-5-2 (2016)
- PL d according to ISO 13849 part 1 (2015)
- Category 3 according to IEC 60204 (2007)

¹⁾ In transport packaging.

²⁾ In product packaging.

Technical specifications (continued)

Line voltage 200 ... 240 V 1 AC		SINAMICS S210 servo converters, 1 AC series			
		6SL3210-5HB10-1UF0	6SL3210-5HB10-2UF0	6SL3210-5HB10-4UF0	6SL3210-5HB10-8UF0
Line supply connection					
• Supply voltage		200 ... 240 V 1 AC ±10 %			
• Line frequency	Hz	50/60			
• Conductor cross-section, max.	mm ²	2.5			
• Line system configuration		Grounded TN/TT networks and ungrounded IT networks			
Rated current	A	1.4	2.7	5	9.3
Inrush current	A	8	8	8	8
Power loss	W	15.7	23.2	38.5	71.1
Electronic power supply					
• Voltage		24 V -15 % ... +20 %			
• Power requirement, max.	A	0.8 without brake For current consumption of the brake, see section SIMOTICS S-1FK2 servomotors > Technical specifications > Holding brake, page 3/9			
• Conductor cross-section, max.	mm ²	2.5			
Output					
• Rated power for motor	kW	0.1	0.2	0.4	0.75
• Rated current for motor	A	0.8	1.36	2.4	4.4
• Output current for motor, max.	A	3.1	4.8	8.7	16
Pulse frequency power unit	kHz	8			
Output frequency	Hz	0 ... 550			
Line filter		Integrated, category C2 (up to 10 m (32.8 ft) cable length), category C3 (up to 25 m (82.0 ft) cable length)			
Braking resistor		Without ¹⁾	Integrated	Integrated	Integrated
Digital inputs ²⁾					
• Fast inputs for measuring probes, reference marks, temperature monitoring, external braking resistor		3			
- Low level		-30 V ... +5 V and ≤ 2 mA			
- High level		15 V ... 30 V			
- Current consumption	mA	6			
- Delay time, typ., L → H	µs	5			
- Delay time, typ., H → L	µs	50			
- Galvanic isolation		No			
• Fail-safe input		1			
- Low level		-30 V ... +5 V and ≤ 2 mA			
- High level		15 V ... 30 V			
- Current consumption	mA	5			
- Delay time, typ., L → H	µs	50			
- Delay time, typ., H → L	µs	100			
- Galvanic isolation		Yes			
• Conductor cross-section, max.	mm ²	1.5			
Cooling		Convection (without fan)			
Frame size		FSA		FSB	FSC
Dimensions					
• Width	mm (in)	45 (1.77)		55 (2.17)	74.5 (2.93)
• Height	mm (in)	170 (6.69)		170 (6.69)	170 (6.69)
• Depth	mm (in)	170 (6.69)		170 (6.69)	195 (7.68)
Weight, approx.	kg (lb)	1.1 (2.43)		1.2 (2.65)	1.9 (4.19)

¹⁾ An internal braking resistor is not required for normal operation on account of the available DC link capacity.

²⁾ The specified delay times refer to the hardware. The actual reaction time depends on the time slot in which the digital input is processed.

SINAMICS S210 servo drive

0.1 kW to 7 kW

SINAMICS S210 servo drive**Technical specifications (continued)**

Line voltage 200 ... 480 V 3 AC		SINAMICS S210 servo converters, 3 AC series							
		6SL3210-5HE10-4UF0	6SL3210-5HE10-8UF0	6SL3210-5HE11-0UF0	6SL3210-5HE11-5UF0	6SL3210-5HE12-0UF0	6SL3210-5HE13-5UF0	6SL3210-5HE15-0UF0	6SL3210-5HE17-0UF0
Line supply connection		200 ... 480 V 3 AC ±10 %							
• Supply voltage	Hz	50/60							
• Line frequency	mm ²	6							
• Conductor cross-section, max.		Grounded TN/TT networks, ungrounded IT networks and networks with grounded line conductor only with an isolating transformer							
• Line system configuration									
Rated current	A	1.5	2.9	3.8	5.7	6.9	9.1	12.9	16.8
Inrush current	A	4.3	4.3	4.3	8.6	8.6	27.8	27.8	27.8
Power loss	W	36	67.5	90	135	180	315	450	630
Electronic power supply		24 V -15 % ... +20 %							
• Voltage	A	1.2 without brake							
• Power requirement, max.		For current consumption of the brake, see section SIMOTICS S-1FK2 servomotors > Technical specifications > Holding brake, page 3/9							
• Conductor cross-section, max.	mm ²	2.5							
Output									
• Rated power for motor	kW	0.4	0.75	1	1.5	2	3.5	5	7
• Rated current for motor	A	1.2	2.3	3	5	7	9	12	15
• Output current for motor, max.	A	4.2	7.6	10.9	19	24	33	44	55
Pulse frequency power unit	kHz	8							
Output frequency	Hz	0 ... 550							
Line filter		Category C3 (up to 25 m (82.0 ft) cable length for a single axis, for DC link coupling see Accessories/line filters)							
Braking resistor		Integrated							
Digital inputs ¹⁾		3							
• Fast inputs for measuring probes, reference marks, temperature monitoring, external braking resistor		-30 V ... +5 V and ≤ 2 mA							
- Low level		15 V ... 30 V							
- High level	mA	6							
- Current consumption	μs	5							
- Delay time, typ., L → H	μs	50							
- Delay time, typ., H → L		No							
- Galvanic isolation		1							
• Fail-safe input		-30 V ... +5 V and ≤ 2 mA							
- Low level		15 V ... 30 V							
- High level	mA	5							
- Current consumption	μs	50							
- Delay time, typ., L → H	μs	100							
- Delay time, typ., H → L		Yes							
- Galvanic isolation	mm ²	1.5							
• Conductor cross-section, max.									
Cooling		Air cooling with integrated fan							
Frame size		FSA			FSB		FSC		
Dimensions									
• Width	mm (in)	50 (1.97)			70 (2.76)		105 (4.13)		
• Height	mm (in)	231 (9.09)			280 (11.0)		280 (11.0)		
• Depth	mm (in)	223 (8.78)			223 (8.78)		223 (8.78)		
Weight, approx.	kg (lb)	2.1 (4.63)			3.3 (7.28)		5 (11.03)		

¹⁾ Available soon.¹⁾ The specified delay times refer to the hardware. The actual reaction time depends on the time slot in which the digital input is processed.

Dimensional drawings

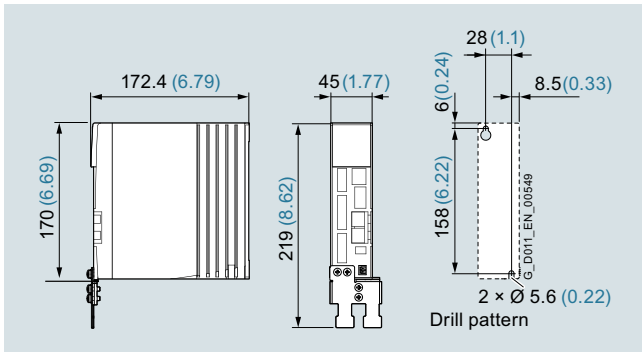

Dimension drawing SINAMICS S210, frame size FSA, 1 AC series

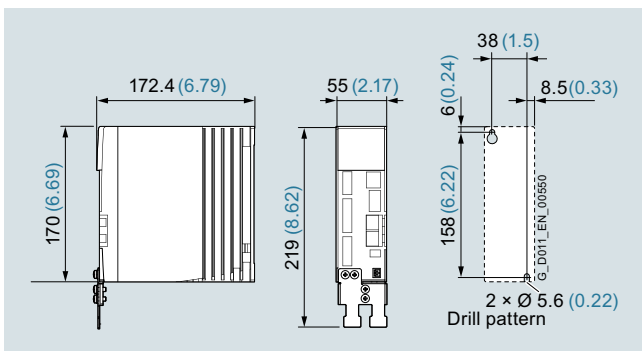

Dimension drawing SINAMICS S210, frame size FSB, 1 AC series

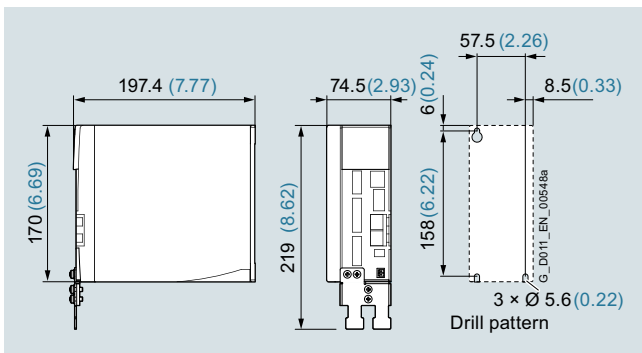

Dimension drawing SINAMICS S210, frame size FSC, 1 AC series

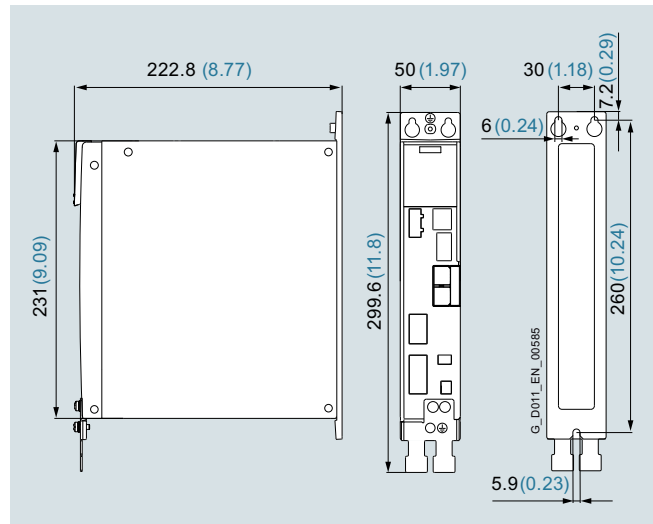

Dimension drawing SINAMICS S210, frame size FSA, 3 AC series

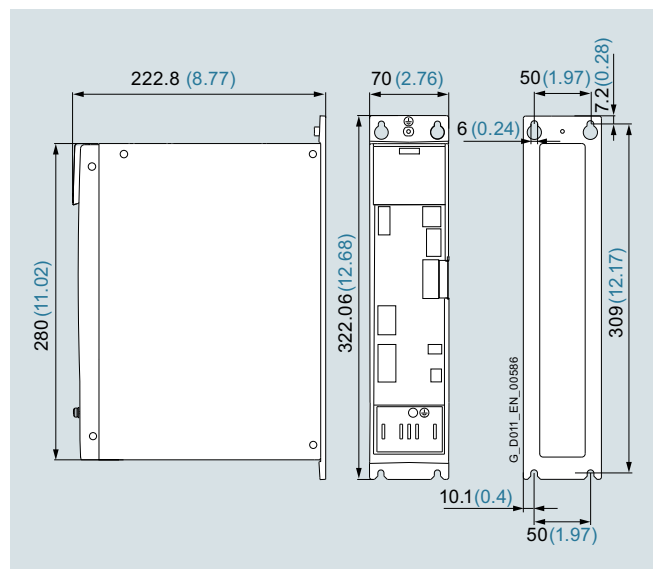

Dimension drawing SINAMICS S210, frame size FSB, 3 AC series

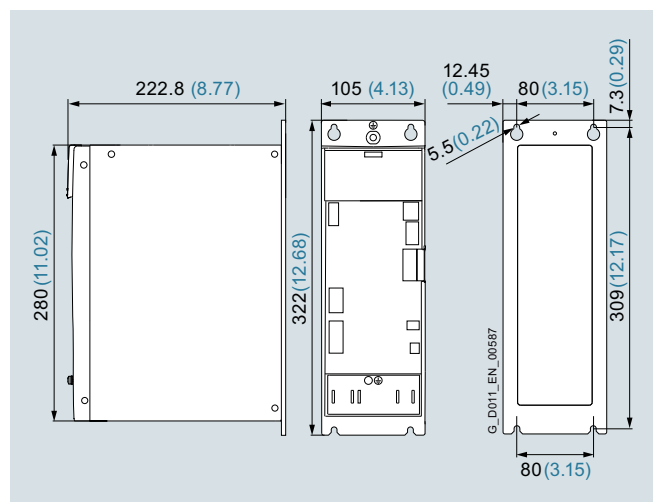

Dimension drawing SINAMICS S210, frame size FSC, 3 AC series

All dimensions in mm (values in brackets are in inches).

With the OCC motor connection cable connected, the overall depth increases by 56.6 mm (2.28 inches).

SINAMICS S210 servo drive

0.1 kW to 7 kW

SINAMICS S210 servo drive

Accessories

Line filters

1 AC series

Filters are already integrated in order to achieve category C2 (for motor cable lengths up to 10 m) or category C3 (for motor cable lengths up to 25 m). Further requirements can be achieved using an external line filter.

1 AC series	Maximum motor cable length	
	for converters without additional line filter	for converters with external line filter
EMC category C2	10 m	25 m
EMC category C3	25 m	50 m

3 AC series

Filters for achieving category C3 are already integrated (for motor cable lengths up to 25 m). Further requirements can be achieved using an external line filter ¹⁾.

3 AC series	DC link coupling	Maximum motor cable length	
		for converters with integrated line filter	for converters with external line filter
EMC category C3	Without DC link coupling	25 m	50 m
	With DC link coupling ≤ 6 converters ²⁾	100 m	250 m

Recommended line-side overcurrent protection devices

Overcurrent protection devices are absolutely necessary for the operation of the converters. The table listed in the section "Recommended line-side overcurrent protection devices" provides recommendations according to IEC and UL regulations, depending on the area of application. Recommendations on further overcurrent protection devices are available at: <https://support.industry.siemens.com/cs/document/109748999>

Additional information about the listed Siemens fuses is available in Catalog LV 10 as well as in the Industry Mall.

Braking resistors

As far as necessary, braking resistors are integrated into the converters. Together with the generously dimensioned DC link capacities, an external braking resistor is not necessary in the normal case.

If the internal braking resistor is inadequate for applications with very high requirements, an external braking resistor can be connected as an alternative.

Memory cards

A memory card (SINAMICS SD card) can be optionally used with SINAMICS S210. The associated slot is located under the front cover of the converter. Not only the firmware but also the device parameterization of a SINAMICS S210 servo converter can be stored on the memory card.

When service is required, e.g. after the converter has been replaced and the data have been downloaded from the memory card, the drive system is immediately ready for use again.

A memory card is only absolutely necessary if functions requiring license, such as the Extended Safety Functions, are used. The necessary license is saved on the memory card.

¹⁾ External line filters available soon.

²⁾ The data is applicable for the complete cable length of the motors, whose associated converters are coupled with one another through the DC link. The maximum cable length for a motor is 50 m (164 ft).

Technical specifications

Line voltage 200 ... 240 V 1 AC		Line filter ¹⁾
		6SL3203-0BB21-8VA0
Rated current	A	18
Line/load connection		Screw terminals
• Conductor cross-section	mm ²	10
PE connection		M5 screw stud
Degree of protection		IP20
Dimensions		
• Width	mm (in)	59 (2.32)
• Height	mm (in)	155 (6.10)
• Depth	mm (in)	53 (2.09)
Weight, approx.	kg (lb)	0.9 (1.98)
Suitable for SINAMICS S210 servo converter		Type
		6SL3210-5HB10-1UF0 (0.1 kW)
		6SL3210-5HB10-2UF0 (0.2 kW)
		6SL3210-5HB10-4UF0 (0.4 kW)
		6SL3210-5HB10-8UF0 (0.75 kW)

Line filter for 200 ... 480 V 3 AC available soon.

Selection and ordering data

Rated power of the servo converter	Suitable for SINAMICS S210	Line filter
kW		Article No.
Line voltage 200 ... 240 V 1 AC		
0.1	6SL3210-5HB10-1UF0	6SL3203-0BB21-8VA0
0.2	6SL3210-5HB10-2UF0	
0.4	6SL3210-5HB10-4UF0	
0.75	6SL3210-5HB10-8UF0	

¹⁾ The line filter does not have UL approval.

SINAMICS S210 servo drive

0.1 kW to 7 kW

Line-side components > Recommended line-side overcurrent protection devices**Selection and ordering data**

Overcurrent protection devices are absolutely necessary for the operation of the converters. The following table lists recommendations for fuses.

- Siemens fuses of type 3NA3 for use in the area of validity of IEC
- UL-listed fuses Class J for use in USA and Canada

Recommendations on further overcurrent protection devices are available at:

<https://support.industry.siemens.com/cs/document/109748999>

The Short Circuit Current Rating (SCCR) according to UL for industrial control cabinet installations to NEC Article 409 or UL 508A/508C or UL 61800-5-1 is as follows for Class J fuses for

- SINAMICS S210: 65 kA

SCCR and ICC values for combination with further overcurrent protection devices are available at:

<https://support.industry.siemens.com/cs/document/109748999>

Notes for installations in Canada:

The converters are intended for line supply systems with overvoltage category III.

More information is available in the technical documentation on the Internet at:

www.siemens.com/sinamics-s210/documentation

Additional information about the listed Siemens fuses is available in Catalog LV 10 as well as in the Industry Mall.

Rated power kW	SINAMICS S210 Type	IEC-compliant Fuse		UL/cUL-compliant Fuse type Rated voltage 600 V AC	
		Current A	3NA3 Article No.	Class	Current A
Line voltage 200 ... 240 V 1 AC					
0.1	6SL3210-5HB10-1UF0	6	3NA3801	J	6
0.2	6SL3210-5HB10-2UF0	6	3NA3801	J	6
0.4	6SL3210-5HB10-4UF0	10	3NA3803	J	10
0.75	6SL3210-5HB10-8UF0	16	3NA3805	J	20
Line voltage 200 ... 480 V 3 AC					
0.4	6SL3210-5HE10-4UF0	16	3NA3805	J	15
0.75	6SL3210-5HE10-8UF0	16	3NA3805	J	15
1	6SL3210-5HE11-0UF0	16	3NA3805	J	15
1.5	6SL3210-5HE11-5UF0	32	3NA3812	J	30
2	6SL3210-5HE12-0UF0	32	3NA3812	J	30
3.5	6SL3210-5HE13-5UF0	63	3NA3822	J	70
5	6SL3210-5HE15-0UF0	63	3NA3822	J	70
7	6SL3210-5HE17-0UF0	63	3NA3822	J	70

Group protection of multiple converters

Further information can be found in the operating instructions on the Internet at

www.siemens.com/sinamics-s210/documentation

Overview

As far as necessary, braking resistors are integrated into the converters. Together with the generously dimensioned DC link capacities, another external braking resistor is not necessary in the normal case.

If the internal braking resistor is inadequate for applications with very high requirements, an external braking resistor can be connected as an alternative.

Only intrinsically safe braking resistors with temperature monitoring may be used in order to minimize the risk of an explosion, the outbreak of fire or melting of the enclosure in the event of a continuous overload, e.g. due to a defect.

Technical specifications

Requirements placed on an external braking resistor

Converter	Braking resistor			
	Rated power kW	Resis- tance Ω	Contin- ous power W	Peak braking power kW
Line voltage 200 ... 240 V 1 AC				
6SL3210-5HB10-1UF0	0.1	150	50	1.09
6SL3210-5HB10-2UF0	0.2	150	100	1.09
6SL3210-5HB10-4UF0	0.4	100	200	1.64
6SL3210-5HB10-8UF0	0.75	50	380	3.28
Line voltage 200 ... 480 V 3 AC				
6SL3210-5HE10-4UF0	0.4	200	200	3
6SL3210-5HE10-8UF0	0.75	200	380	3
6SL3210-5HE11-0UF0	1	200	500	3
6SL3210-5HE11-5UF0	1.75	100	880	6
6SL3210-5HE12-0UF0	2	100	1000	6
6SL3210-5HE13-5UF0	3.5	30	1750	20
6SL3210-5HE15-0UF0	5	30	2500	20
6SL3210-5HE17-0UF0	7	30	3250	20

More Information

Further information is available from the "Siemens Product Partner for Drives Options":

www.siemens.com/drives-options-partner

SINAMICS S210 servo drive

0.1 kW to 7 kW

Supplementary system components > Memory cards

Overview

SINAMICS memory card (SD card)

The parameter assignment, firmware and licenses for a converter can be stored on the SINAMICS memory card (SD card). When service is required, e.g. after the converter has been replaced and the data have been downloaded from the memory card the drive system is immediately ready for use again.

The memory card has the following functions:

- Parameter settings can be written from the memory card to the converter or saved from the converter to the memory card
- The memory card supports series commissioning without the use of a commissioning tool
- If firmware is stored on the memory card, the firmware can be upgraded/downgraded during startup
- It is used for storing licenses when using functions under license, e.g. the license for enabling the Extended Safety Functions
 - Safe Stop 2 (SS2)
 - Safe Operating Stop (SOS)
 - Safely-Limited Speed (SLS)
 - Safe Speed Monitor (SSM)
 - Safe Direction (SDI)
 - Safely-Limited Acceleration (SLA)
 - Safe Brake Test (SBT) diagnostic function

Note:

In general, the converter can be operated without a memory card. However, it is necessary if licenses, such as the Extended Safety license, are required. The card must then remain permanently inserted.

Selection and ordering data

Description	Article No.
SINAMICS SD card 512 MB Firmware V5.2 or higher is required for the 3 AC series.	
• Empty	6SL3054-4AG00-2AA0
• With firmware V5.1	6SL3054-4FB00-2BA0
• With firmware V5.1 SP1	6SL3054-4FB10-2BA0
• With firmware V5.1 SP1 and Safety license (Extended Functions)	6SL3054-4FB10-2BA0-Z F01
• With firmware V5.2 NEW	6SL3054-4FC00-2BA0
• With firmware V5.2 and Safety license (Extended Functions) NEW	6SL3054-4FC00-2BA0-Z F01
Safety license (Extended Functions) ¹⁾	6SL3074-0AA10-0AA0

¹⁾ Extended function for an existing memory card (firmware V5.1 SP1 or higher). The memory card is not included in the scope of delivery. The Safety license can also be ordered together with a memory card (see above).

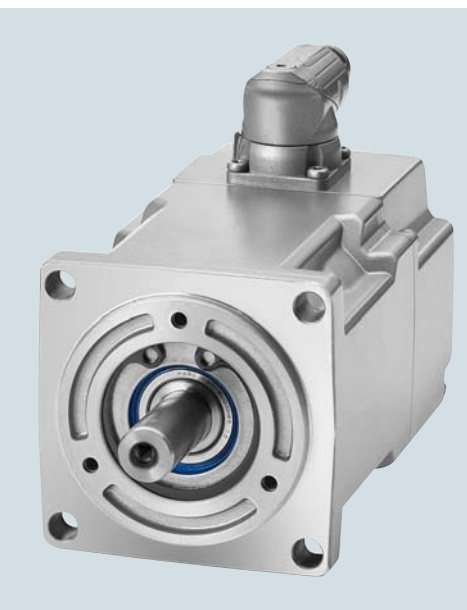
SIMOTICS S-1FK2 servomotors**3/2 SIMOTICS S-1FK2 servomotors for SINAMICS S210**

3/2	Overview
3/2	Benefits
3/2	Application
3/3	Selection and ordering data
3/5	Technical specifications
3/5	General technical specifications
3/10	SIMOTICS S-1FK2 shaft height 20
3/12	SIMOTICS S-1FK2 shaft height 30
3/14	SIMOTICS S-1FK2 shaft height 40

Detailed technical information on the SINAMICS S210 servo drive system is available on the Internet at:

www.siemens.com/sinamics-s210/documentation

In addition, the Drive Technology Configurator (DT Configurator) can be used on the Internet at the following address:

www.siemens.com/dt-configurator

SIMOTICS S-1FK2 servomotors

SIMOTICS S-1FK2 servomotors for SINAMICS S210

Overview

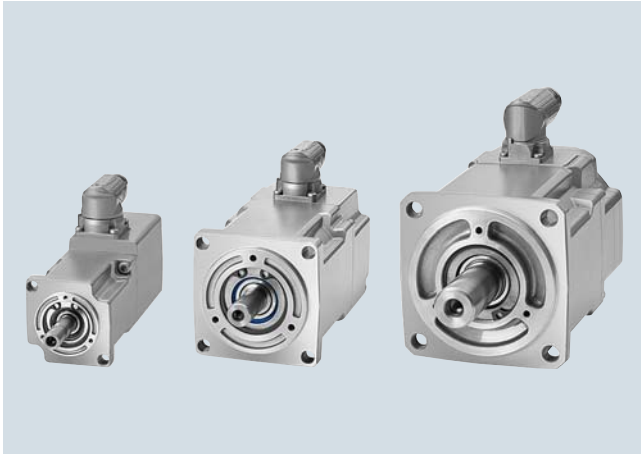

The SIMOTICS S-1FK2 servomotors are compact and highly dynamic synchronous motors for a wide range of uses in an industrial environment. They are characterized by high power density, degree of protection and overload capability.

SIMOTICS S-1FK2 High Dynamic motors

Highest dynamic response through low inertia for highly dynamic applications with low moved masses.

SIMOTICS S-1FK2 Compact motors

Precise, stable control with medium to high masses to be moved with medium moment of inertia.

Benefits

The SIMOTICS S-1FK2 servomotors fully exploit their strengths in the system with the SINAMICS S210 converter:

- Short adjustment and positioning times
- Quick and precise compensation of disturbances
- Stable closed loop control with high dynamic response





This is achieved by:

- Rapid control cycle
- High pulse frequency
- Complex rule algorithms
- High-resolution optical encoder with fast scanning
- Low moment of inertia of the motors
- High overload capability

Application

- Packaging machines
- Handling equipment
- Feed and withdrawal devices
- Stacking units
- Automatic assembly machines
- Laboratory automation
- Woodworking, glass and ceramic industries
- Digital printing machines

Selection and ordering data

	Static torque M_0 Nm (lb _f -ft)	Maximum torque M_{max} Nm (lb _f -ft)	Maximum speed n_{max} rpm	Rated speed for 200 ... 240 V 1/3 AC n_{rated} rpm	Rated speed for 400 ... 480 V 3 AC n_{rated} rpm	Rotor moment of inertia J_{Mot} kg cm ² (lb _f -in ²)	SIMOTICS S-1FK2 servomotor Article No.
High Dynamic for highly dynamic applications							
Shaft height 20 – rated speed n_{rated} 3000 rpm							
	0.16 (0.12)	0.56 (0.41)	8000	3000	–	0.0245 (0.008)	1FK2102-0AG ■■■ ■■■ A0
	0.32 (0.24)	1.11 (0.82)	8000	3000	–	0.036 (0.012)	1FK2102-1AG ■■■ ■■■ A0
Shaft height 30 – rated speed n_{rated} 3000 rpm							
	0.64 (0.47)	1.95 (1.44)	8000	3000	–	0.093 (0.032)	1FK2103-2AG ■■■ ■■■ A0
	1.27 (0.94)	4.05 (2.99)	7300	3000	–	0.139 (0.047)	1FK2103-4AG ■■■ ■■■ A0
Shaft height 40 – rated speed n_{rated} 3000 rpm							
	1.27 (0.94)	3.75 (2.77)	7200	–	3000	0.35 (0.120)	NEW 1FK2104-4AF ■■■ ■■■ A0
	1.27 (0.94)	3.85 (2.84)	7500	3000	–	0.35 (0.120)	1FK2104-4AK ■■■ ■■■ A0
	2.4 (1.77)	7.5 (5.53)	6700	–	3000	0.56 (0.191)	NEW 1FK2104-5AF ■■■ ■■■ A0
	2.4 (1.77)	7.6 (5.61)	7100	3000	–	0.56 (0.191)	1FK2104-5AK ■■■ ■■■ A0
	3.2 (2.36)	10 (7.38)	7200	–	3000	0.76 (0.260)	NEW 1FK2104-6AF ■■■ ■■■ A0
Compact for high precision applications							
Shaft height 30 – rated speed n_{rated} 3000 rpm							
	0.64 (0.47)	1.85 (1.36)	8000	3000	–	0.2 (0.068)	1FK2203-2AG ■■■ ■■■ A0
	1.27 (0.94)	3.75 (2.77)	7800	3000	–	0.35 (0.120)	1FK2203-4AG ■■■ ■■■ A0
Shaft height 40 – rated speed n_{rated} 3000 rpm							
	2.4 (1.77)	7.1 (5.24)	7500	–	3000	1.23 (0.420)	NEW 1FK2204-5AF ■■■ ■■■ A0
	2.4 (1.77)	7.1 (5.24)	7500	3000	–	1.23 (0.420)	NEW 1FK2204-5AK ■■■ ■■■ A0
	3.2 (2.36)	9.5 (7.01)	7600	–	3000	1.61 (0.550)	NEW 1FK2204-6AF ■■■ ■■■ A0

Article No. supplements

Holding brake

Without brake	0
With brake	1

Degree of protection

IP64 (without shaft sealing ring)	0
IP65 (with shaft sealing ring)	1

Shaft extension, feather key

Plain shaft	0
Shaft with feather key	1
Plain shaft Ø11 × 23 mm (0.43 × 0.91 in) (only for 1FK2 . 03 and IP64)	0 2

Encoder

Absolute encoder 22-bit singleturn	S
Absolute encoder 22-bit + 12-bit multiturn	M

Accessories

Design	Description	For motor	Article No.
	Shaft sealing ring	1FK2 . 02	1FK2902-0GC00
	To achieve degree of protection IP65	1FK2 . 03	1FK2903-0GC00
	Degree of protection kit for mounting on the motor for retrofitting or as spare part	1FK2 . 04	1FK2904-0GC00

SIMOTICS S-1FK2 servomotors

SIMOTICS S-1FK2 servomotors for SINAMICS S210

Selection and ordering data (continued)

Structure of the Article No. of the SIMOTICS S-1FK2 servomotors

Data position in Article No.	1	2	3	4	5	6	7	8	9	10	11	12	13	14	15	16		
	1	F	K	2	■	■	■	-	■	A	■	■	■	-	■	■	A	0
1st to 4th position: digit, letter, letter, digit	Motor 1 F K 2																	
5th position: digit	Moment of inertia																	
	High Dynamic				1													
	Compact				2													
6th and 7th positions: digit, digit	Shaft height																	
	20					0	2											
	30					0	3											
	40					0	4											
8th position: digit	Overall length																	
	See specific technical specifications							0 ... 8										
9th position: letter	Reserved								A									
10th position: letter	Winding/rated speed																	
	For converters connected to max. 240 V				For converters connected to max. 480 V													
	3000 rpm at 230 V				Not permissible						G							
	1500 rpm at 230 V				3000 rpm at 400 V						F							
	3000 rpm at 230 V				6000 rpm at 400 V						K							
11th position: digit	Brake																	
	None															0		
	Holding brake															1		
12th position: digit	Degree of protection																	
	IP64 (without shaft sealing ring)															0		
	IP65 (with shaft sealing ring)															1		
13th position: digit	Shaft extension, feather key																	
	Plain shaft																0	
	Shaft with feather key																1	
	Plain shaft Ø11 × 23 mm (0.43 × 0.91 in) (only for 1FK2 . 03 and IP64)																2	
14th position: letter	Encoder																	
	Absolute encoder 22-bit singleturn (AS22DQC)																	S
	Absolute encoder 22-bit + 12-bit multiturn (AM22DQC)																	M
15th position: letter	One Cable Connection																	A
16th position: digit	Reserved																	0

Technical specifications

General technical specifications

SIMOTICS S-1FK2 High Dynamic/Compact motors	
Motor type	Permanent-magnet synchronous motor
Permissible operating conditions without derating • Ambient temperature • Installation altitude, max.	-15 ... +40 °C (5 ... 104 °F) 1000 m (3281 ft)
Degree of protection According to EN 60034-5 (IEC 60034-5)	IP64 IP65 optional or retrofittable
Cooling According to EN 60034-6	Natural cooling (IC410)
Type of construction According to EN 60034-7 (IEC 60034-7)	IM B5 (IM V1, IM V3)
Shaft extension According to DIN 748-3 (IEC 60072-1)	Plain shaft Optional shaft with feather key (half-key balancing)
Shaft and flange accuracy According to DIN 42955 (IEC 60072-1)	Tolerance N In each case for radial eccentricity of the shaft extension, concentricity of the centering ring, and axial eccentricity of the mounting flange to the axis of the shaft extension.
Vibration severity grade According to EN 60034-14 (IEC 60034-14)	Grade A is maintained up to rated speed
Stator winding insulation According to EN 60034-1 (IEC 60034-1) • 1FK2102, 1FK2 . 03 • 1FK2 . 04, 1FK2 . 05, 1FK2 . 06, 1FK2 . 08, 1FK2 . 10	Thermal class 130 (B) for a winding overtemperature of $\Delta T = 80$ K Thermal class 155 (F) for a winding overtemperature of $\Delta T = 100$ K
Sound pressure level L_{pA} (1 m), max. According to ISO 1680 • 1FK2102, 1FK2 . 03, 1FK2 . 04 • 1FK2 . 05 and 1FK2 . 06 • 1FK2 . 08 and 1FK2 . 10	55 dB +3 dB tolerance 65 dB +3 dB tolerance 70 dB +3 dB tolerance
Encoder system	• AS22DQC (absolute encoder 22-bit singleturn) • AM22DQC (absolute encoder 22-bit + 12-bit multiturn)
Holding brake	Optional integrated holding brake
Connection	One Cable Connection (OCC) for signals and power Rotatable connector
Paint finish	RAL 7016 (anthracite gray)
Certificates of suitability	cURus, CE

SIMOTICS S-1FK2 servomotors

SIMOTICS S-1FK2 servomotors for SINAMICS S210

Technical specifications (continued)

Regulations, standards, specifications

The motors comply with the appropriate standards and regulations, see table below.

As a result of the fact that in many countries the national regulations have been completely harmonized with the international IEC 60034-1 recommendation, there are no longer any differences with respect to coolant temperatures, temperature classes and temperature rise limits.

General specifications for rotating electrical machines	IEC 60034-1
Terminal designations and direction of rotation for electrical machines	IEC 60034-8
Types of construction of rotating electrical machines	IEC 60034-7
Cooling methods of rotating electrical machines	IEC 60034-6
Degrees of protection of rotating electrical machines	IEC 60034-5
Vibration severity of rotating electrical machines	IEC 60034-14
Noise limit values for rotating electrical machines	IEC 60034-9
Cylindrical shaft extensions for electrical machines	DIN 748-3/IEC 60072-1



SIMOTICS S-1FK2 motors have UL approval from Underwriters Laboratories Inc. and are marked with the "UL Recognized Component" test symbol. This is used for components which are part of a larger product or system. This confirmed compliance with the corresponding US American and Canadian regulations, and allowed access to the North American market.



For SIMOTICS S-1FK2 motors, conformity with the relevant EC directives 2006/95/EC and 2014/35/EU and the relevant standards EN 60034-1:2010 and EN 60204-1:2006 is confirmed. By applying the CE mark to the product, Siemens AG confirms this for the product, and secures the free movement of goods within the European Union.

Degree of protection acc. to IEC 60034-5

A suitable degree of protection must be selected according to the operating and environmental conditions to protect the machine against damage caused by the ingress of water and other liquids, as well as dust and foreign bodies.

SIMOTICS S-1FK2 motors have degree of protection IP64 as standard.

The motor can be optionally supplied with a radial shaft seal ring in degree of protection IP65. This increases the protection against the ingress of liquids.

The degree of protection designation is composed from the code **IP** (for International Protection) and two code numbers for the protection against touching and penetration of foreign bodies, and the degree of protection against the ingress of water.

First code number

6: Protection against dust ingress and complete protection against touching

Second code number

4: Protection against splashwater from any direction

5: Protection against jet water from any direction

Recommended degrees of protection for AC motors

When cooling lubricants are used, protection against water alone is inadequate. The IP rating should only be considered as a guide value in this case. The motors may have to be protected by suitable covers. Attention must be paid to providing suitable sealing of the motor shaft for the selected degree of protection for the motor.

The following table can serve as a decision aid for selecting the proper degree of protection for motors. A permanent covering of liquid on the flange must be avoided when the motor is mounted with the shaft extension facing upwards (IM V3).

Effect	General workshop environment	Water/ general cooling lubricant (95 % water, 5 % oil)
Dry	IP64	–
Water-enriched environment	–	IP64
Mist	–	IP65
Spray	–	IP65

Technical specifications (continued)

Type of construction, mounting position according to IEC 60034-7

SIMOTICS S-1FK2 motors are designed in type of construction IM B5. It can also be used in mounting positions IM V1 and IM V3.

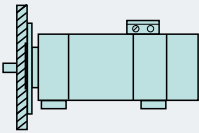
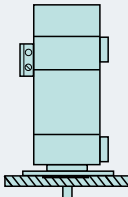
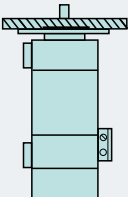
Code 1	IM B5	IM V1	IM V3
Code 2	IM 3001	IM 3011	IM 3031
			
	Horizontal flange mounting	Flange mounting, output shaft pointing vertically downwards	Flange mounting, output shaft pointing vertically upwards

Shaft and flange accuracy in accordance with IEC 60072-1

Radial eccentricity tolerance of shaft in relation to housing axis

(referred to cylindrical shaft extensions)

Motor	Shaft extensions	Radial eccentricity Tolerance N
	D × L	
	mm (in)	µm
1FK2 . 02	8 × 25 (0.31 × 0.98)	30
1FK2 . 03	14 × 30 (0.55 × 1.18)	35
	11 × 23 (0.43 × 0.91)	
1FK2 . 04	19 × 40 (0.75 × 1.57)	40
1FK2 . 05	19 × 40 (0.75 × 1.57)	
1FK2 . 06	24 × 50 (0.94 × 1.97)	
1FK2 . 08	32 × 58 (1.26 × 2.28)	50
1FK2 . 10	38 × 80 (1.50 × 3.15)	

Concentricity and axial eccentricity tolerance of the flange surface for the shaft axis

(referred to the centering diameter of the mounting flange)

Motor	Centering diameter	Concentricity and axial eccentricity Tolerance N
	mm (in)	
	mm (in)	µm
1FK2 . 02	30 (1.18)	80
1FK2 . 03	50 (1.97)	
1FK2 . 04	70 (2.76)	
1FK2205	80 (3.15)	
1FK2105	95 (3.74)	100
1FK2 . 06	110 (4.33)	
1FK2 . 08	130 (5.12)	
1FK2 . 10	130 (5.12)	

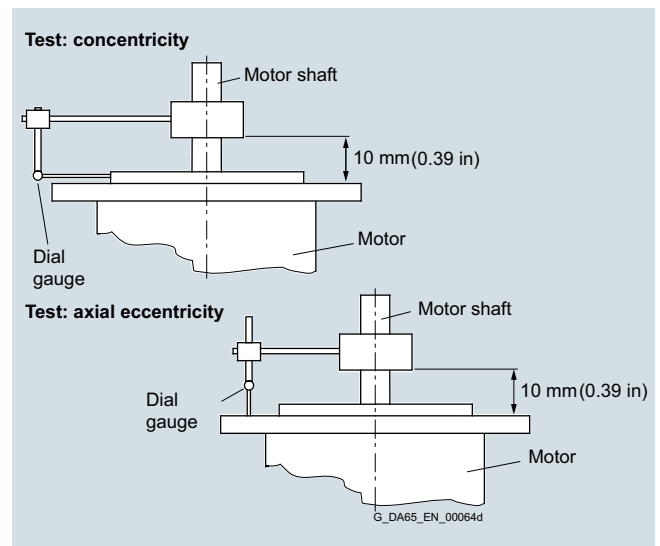
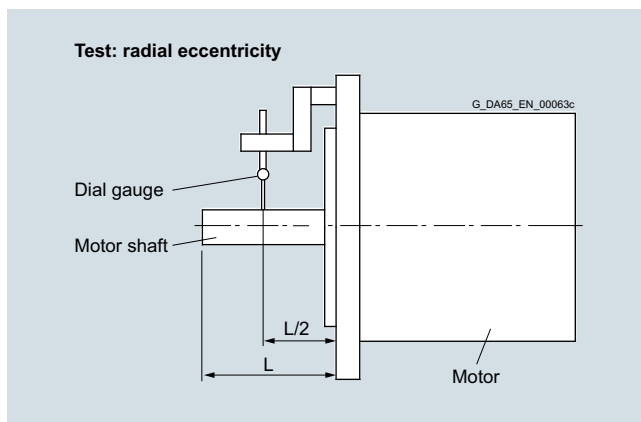

SIMOTICS S-1FK2 servomotors

SIMOTICS S-1FK2 servomotors for SINAMICS S210

Technical specifications (continued)

Vibration severity and vibration severity grade A according to IEC 60034-14

The vibration severity is the RMS value of the vibration velocity (frequency range from 10 Hz to 1000 Hz). The vibration severity is measured using electrical measuring devices according to DIN 45666.

The specified values refer only to the motor. These values can increase as a result of the overall system vibrational behavior due to installation.

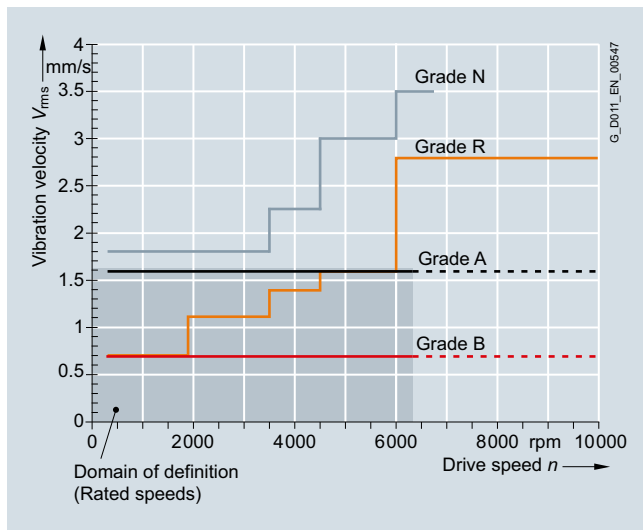

Vibration severity limit values

The speeds of 1800 rpm and 3600 rpm and the associated limit values are specified according to IEC 60034-14. The speeds of 4500 rpm and 6000 rpm and the specified values are defined by the motor manufacturer.

The motors maintain vibration severity grade A up to the rated speed.

Balancing according to ISO 21940-32

Apart from the balance quality of the motor, the vibrational quality of motors with attached pulleys is mainly determined by the balance state of the mounted component. If the motor and the mounted component are balanced separately before being joined, the balancing process of the pulley is to be adapted to the motor's balancing type.

SIMOTICS S-1FK2 motors with feather keys are always half-key balanced. In general, motors with a plain shaft are recommended for systems with the most stringent vibrational quality requirements.

Vibration stress, immitted vibration values

The requirements of environmental class 3M8 (according to EN 60721-3-3 Table 6) must be maintained for proper function and safeguard the bearing life. The following limits are valid for (immitted) vibration values introduced into the motor from outside:

- Vibration velocity V_{rms} according to ISO 10816, max. 4.5 mm/s
- Vibration acceleration a_{peak} axial and radial 50 m/s²

During transport, the motors withstand single shocks (6 ms) of up to 250 m/s².

Ambient temperature and installation altitude

Operating range without restrictions:

Temperature range from -15 °C to +40 °C, installation altitude up to 1000 m.

For all other conditions, the permissible torque must be reduced with the aid of the factors given in the table below. The factors refer to the static torque M_0 . The S1 characteristic must be correspondingly shifted in parallel. Intermediate values must be interpolated correspondingly.

Installation altitude above sea level	Derating factor at an ambient temperature of			
	30 °C (86 °F)	40 °C (104 °F)	45 °C (113 °F)	50 °C (122 °F)
1000 (3281)	1.08	1	0.96	0.91
2000 (6562)	1.02	0.93	0.89	0.84

Encoder systems

In motors with integrated OCC/DRIVE-CLiQ interface, the sensor signal is already digitally prepared in the motor, and then transferred quickly and without loss to the drive system. Motors with an OCC/DRIVE-CLiQ interface simplify commissioning and diagnostics, as the motor parameters and encoder system are identified automatically.

Single-turn absolute encoder

This encoder outputs an absolute angular position between 0° and 360° in the specified resolution. In contrast to the multi-turn absolute encoder, it does not have a revolution counter, and can therefore only supply the position value within one revolution. It does not have a traversing range.

Multi-turn absolute encoder

This encoder outputs an absolute angular position between 0° and 360° in the specified resolution. It can also count 4096 revolutions. So with a ball screw, for example, the absolute position of the slide can be determined over a longer distance.

14th position in the Article No. of the motor	Designation	
1FK2-S..	AS22DQC	Absolute encoder 22-bit singleturn (resolution 4194304)
1FK2-M..	AM22DQC	Absolute encoder 22-bit + 12-bit multiturn (resolution 4194304, traversing range 4096 revolutions)

Technical specifications (continued)**Holding brake**

Many drives need a holding brake with an EMERGENCY STOP function for safety reasons or to meet process requirements. The brakes used on the SIMOTICS S-1FK2 motors function according to the closed-circuit principle. A spring or permanent magnet exerts a tensile force on the brake armature disk, i.e. in a state of zero current, the brake is closed and the motor shaft thereby stopped.

An electric current that flows through a coil generates an opposing field that counteracts the force effect of the spring or permanent magnet and releases or holds open the brake. Only a limited number of braking operations can be performed for an EMERGENCY STOP or power failure without causing excessive wear on the holding brake. The holding brake is not an operational brake. Regular dynamic braking leads to increased wear and premature brake failure. In order to ensure the functionality

and specification of the brake, neither the total operating energy nor the maximum switching energy per braking operation may be exceeded.

The braking signal is already fully integrated into the SINAMICS S210 converter system, so that an external circuit is not necessary.

After an EMERGENCY STOP sequence with the maximum single switching energy, a cooling time of at least 5 minutes must be allowed.

The following table shows the technical specifications of the holding brakes for operation with SINAMICS S210 (for 1 AC devices, hardware version 2 or higher) and firmware V5.2 or higher.

Motor	Shaft height	Holding torque	Dynamic braking torque	Opening time	Closing time	Maximum permissible single switching energy	Total operating energy (service life)	Holding current	Opening current, typ. ¹⁾ for 500 ms
		Nm (lb _f -ft)	Nm (lb _f -ft)	ms	ms	J	kJ	A	A
1FK2 . 02	20	0.32 (0.24)	0.32 (0.24)	25	8	7.4	1.75	0.1	0.6
1FK2 . 03	30	1.3 (0.96)	1.3 (0.96)	40	10	62	17.5	0.15	0.8
1FK2 . 04	40	3.3 (2.43)	3.3 (2.43)	50	15	270	120	0.2	1.2
1FK2 . 05	50	8 (5.90)	5 (3.69)	35	15	570	284	0.3	1.1
1FK2 . 06	63	13 (9.59)	6.5 (4.79)	70	30	1550	774	0.35	1.1
1FK2 . 08-3	80	19 (14.0)	12 (8.85)	70	20	2000	1800	0.4	1.2
1FK2 . 08-4	80	32 (23.6)	17 (12.5)	120	35	4800	2400	0.5	1.4
1FK2208-5	80	32 (23.6)	17 (12.5)	120	35	4800	2400	0.5	1.4
1FK2210-3	100	32 (23.6)	17 (12.5)	120	35	6500	2400	0.5	1.4
1FK2210-4	100	55 (40.6)	26 (19.2)	130	35	8700	3800	0.5	1.5
1FK2210-5	100	55 (40.6)	26 (19.2)	130	35	8700	3800	0.5	1.5

¹⁾ Typical values for an ambient temperature of 20 °C.
At -15 °C, the opening currents may increase by up to 30 %.

SIMOTICS S-1FK2 servomotors

SIMOTICS S-1FK2 servomotors for SINAMICS S210

Technical specifications (continued)

SIMOTICS S-1FK2 shaft height 20

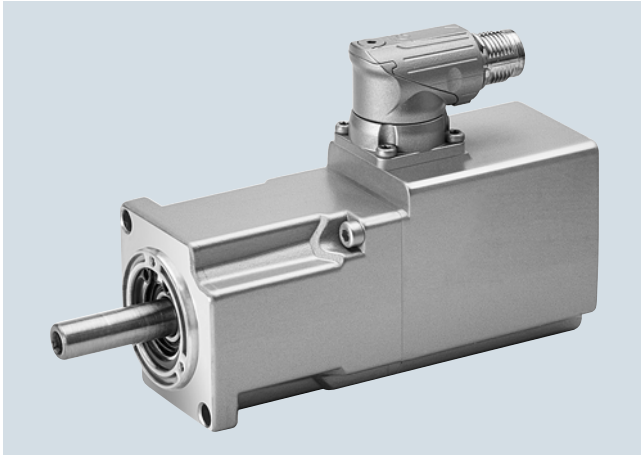

1FK2102-0AG...A0, 50 W

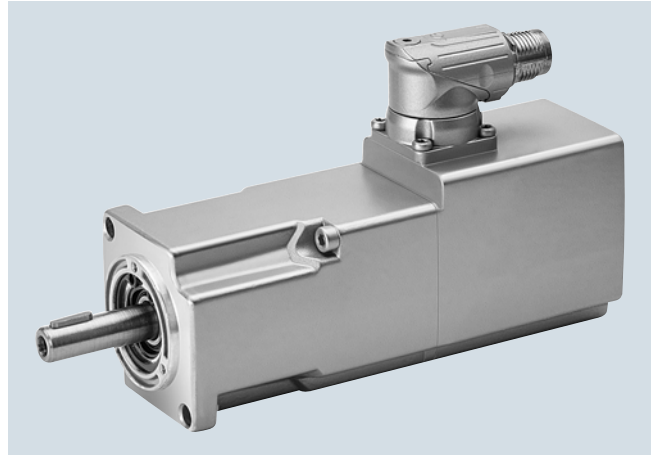

1FK2102-1AG...A0, 100 W

Specific technical specifications

SIMOTICS S-1FK2 servomotors		High Dynamic	
Shaft height 20		1FK2102-0AG...A0	1FK2102-1AG...A0
Static torque M_0	Nm (lb _f -ft)	0.16 (0.12)	0.32 (0.24)
Stall current I_0	A	0.75	0.76
Maximum torque M_{max}	Nm (lb _f -ft)	0.56 (0.41)	1.11 (0.82)
Maximum current I_{max}	A	3.1	2.95
Maximum speed n_{max}	rpm	8000	8000
Rotor moment of inertia J_{Mot}	kg cm ² (lb _f -in ²)	0.0245 (0.008)	0.036 (0.012)
Moment of inertia (with brake) $J_{Mot Br}$	kg cm ² (lb _f -in ²)	0.0285 (0.010)	0.04 (0.014)
Weight m_{Mot}	kg (lb)	0.47 (1.04)	0.60 (1.32)
Weight (with brake) $m_{Mot Br}$	kg (lb)	0.73 (1.61)	0.86 (1.90)
200 ... 240 V 1 AC / 3 AC			
Rated speed n_{rated}	rpm	3000	3000
Rated torque M_{rated}	Nm (lb _f -ft)	0.16 (0.12)	0.32 (0.24)
Rated current I_{rated}	A	0.75	0.76
Rated power P_{rated}	W	50	100
Suitable for SINAMICS S210 servo converter		6SL3210-5HB10-1UF0	6SL3210-5HB10-1UF0

Dimensional drawing

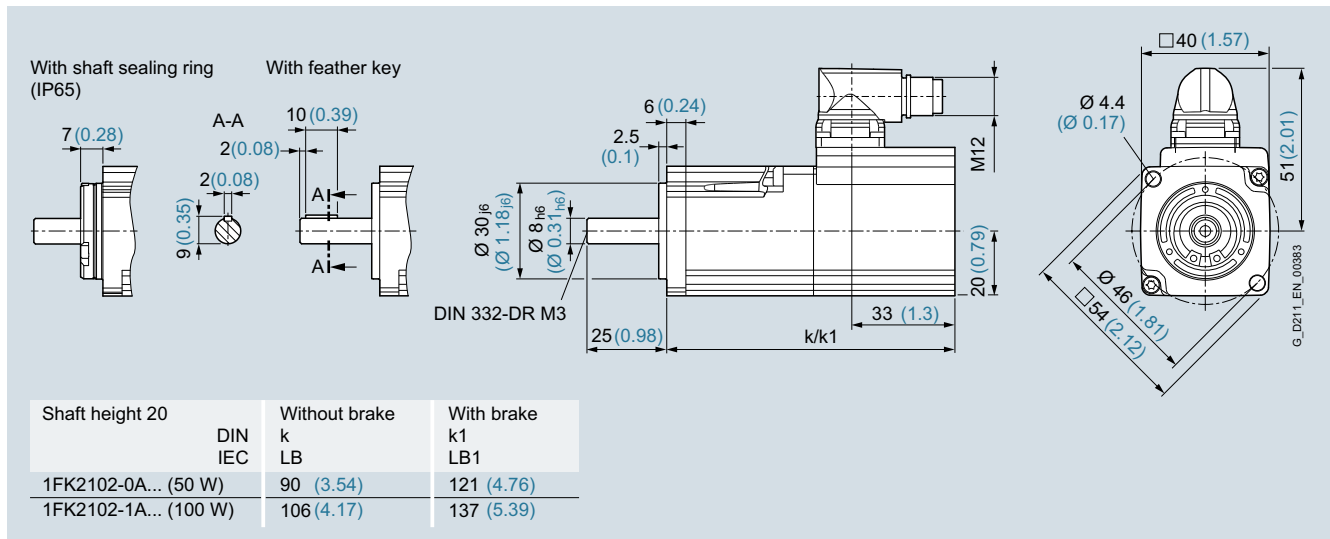

All dimensions in mm (values in brackets are in inches).

Technical specifications (continued)

Speed/torque characteristics

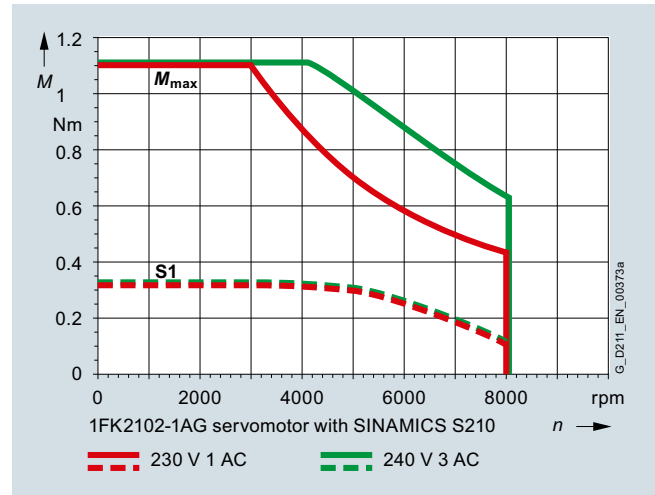
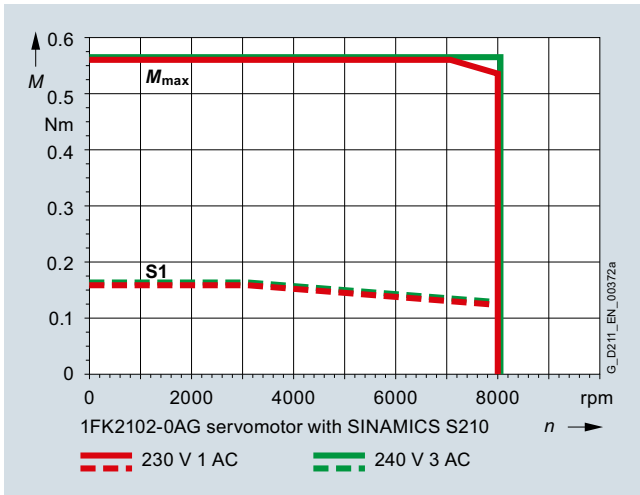

SIMOTICS S-1FK2 servomotors

SIMOTICS S-1FK2 servomotors for SINAMICS S210

Technical specifications (continued)

SIMOTICS S-1FK2 shaft height 30

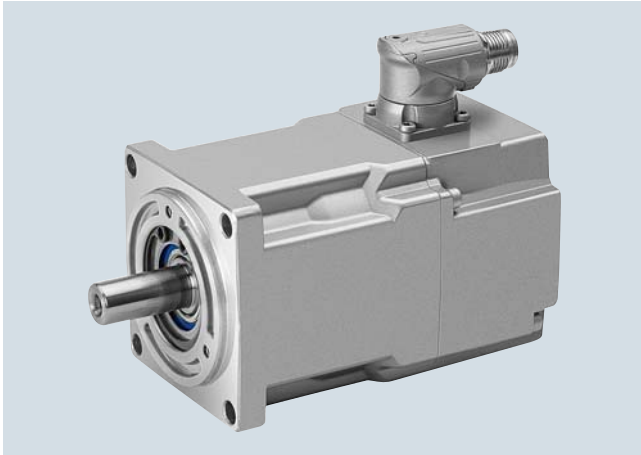

1FK2103-2AG...A0, 200 W

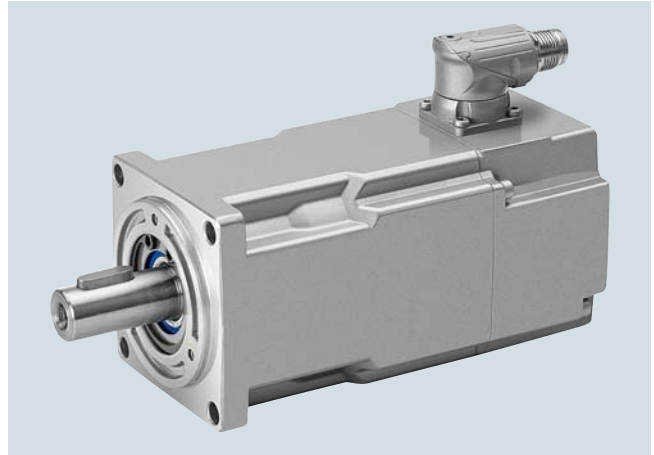

1FK2103-4AG...A0, 400 W

Specific technical specifications

SIMOTICS S-1FK2 servomotors		High Dynamic		Compact	
Shaft height 30		1FK2103-2AG...A0	1FK2103-4AG...A0	1FK2203-2AG...A0	1FK2203-4AG...A0
Static torque M_0	Nm (lb _f -ft)	0.64 (0.47)	1.27 (0.94)	0.64 (0.47)	1.27 (0.94)
Stall current I_0	A	1.36	2.4	1.38	2.52
Maximum torque M_{max}	Nm (lb _f -ft)	1.95 (1.44)	4.05 (2.99)	1.85 (1.36)	3.75 (2.77)
Maximum current I_{max}	A	4.8	8.7	4.2	7.8
Maximum speed n_{max}	rpm	8000	7300	8000	7800
Rotor moment of inertia J_{Mot}	kg cm ² (lb _f -in ²)	0.093 (0.032)	0.139 (0.047)	0.2 (0.068)	0.35 (0.120)
Moment of inertia (with brake) $J_{Mot Br}$	kg cm ² (lb _f -in ²)	0.112 (0.038)	0.158 (0.054)	0.22 (0.075)	0.37 (0.126)
Weight m_{Mot}	kg (lb)	1.16 (2.56)	1.63 (3.59)	1.10 (2.43)	1.57 (3.46)
Weight (with brake) $m_{Mot Br}$	kg (lb)	1.66 (3.66)	2.15 (4.74)	1.60 (3.53)	2.10 (4.63)
200 ... 240 V 1 AC / 3 AC					
Rated speed n_{rated}	rpm	3000	3000	3000	3000
Rated torque M_{rated}	Nm (lb _f -ft)	0.64 (0.47)	1.27 (0.94)	0.64 (0.47)	1.27 (0.94)
Rated current I_{rated}	A	1.36	2.4	1.38	2.52
Rated power P_{rated}	W	200	400	200	400
Suitable for SINAMICS S210 servo converter		6SL3210-5HB10-2UF0	6SL3210-5HB10-4UF0	6SL3210-5HB10-2UF0	6SL3210-5HB10-4UF0

Dimensional drawing

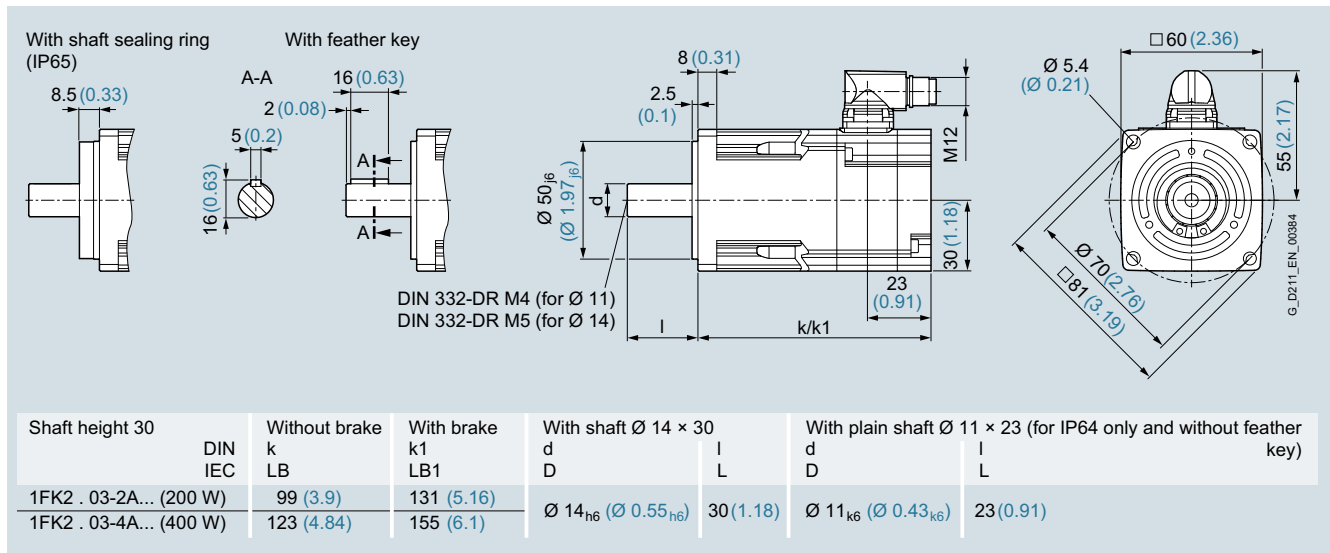

All dimensions in mm (values in brackets are in inches).

Technical specifications (continued)

Speed/torque characteristics

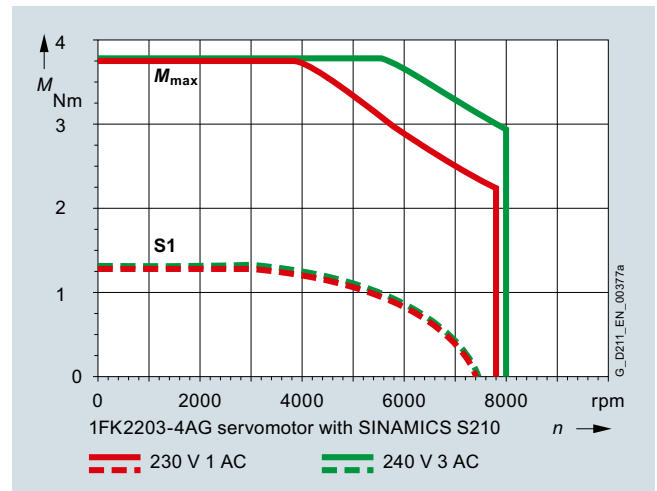
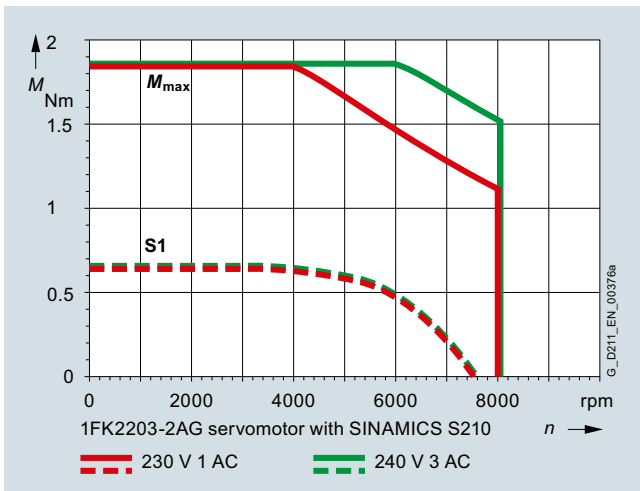
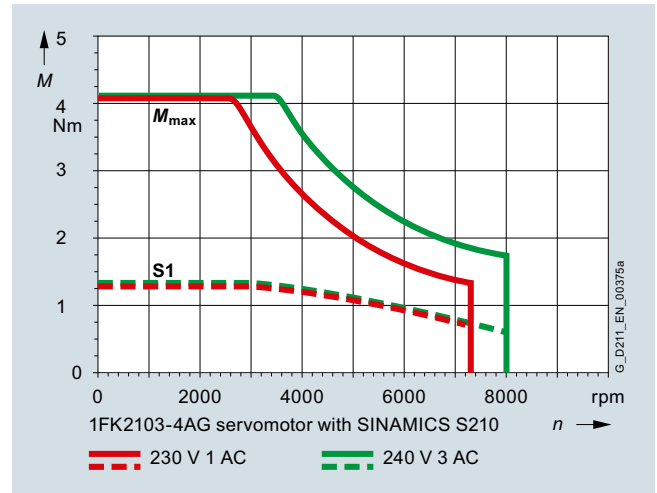
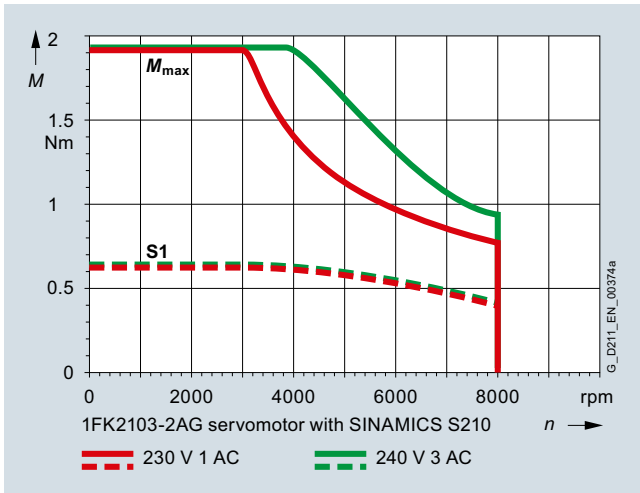

SIMOTICS S-1FK2 servomotors

SIMOTICS S-1FK2 servomotors for SINAMICS S210

Technical specifications (continued)

SIMOTICS S-1FK2 shaft height 40

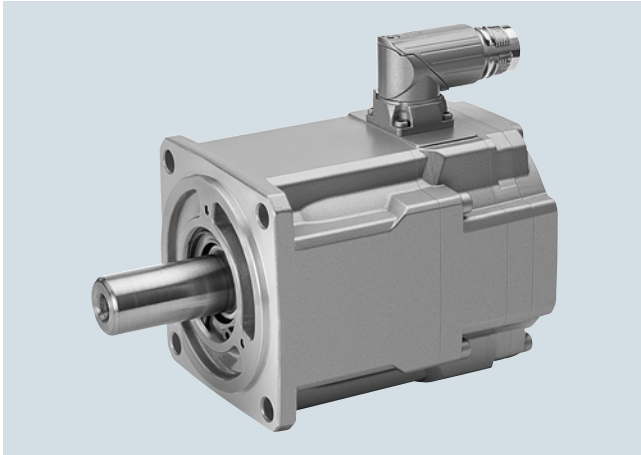

1FK2104-4AK...A0, 400 W

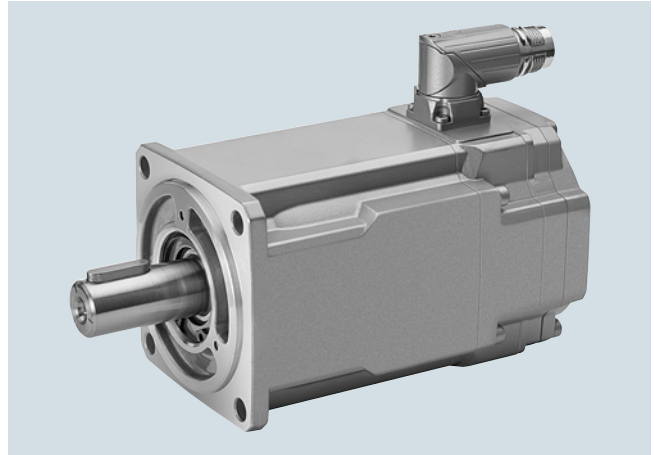

1FK2104-5AK...A0, 750 W

Specific technical specifications

SIMOTICS S-1FK2 servomotors Shaft height 40		High Dynamic					Compact		
		1FK2104-4AF...A0	1FK2104-4AK...A0	1FK2104-5AF...A0	1FK2104-5AK...A0	1FK2104-6AF...A0	1FK2204-5AF...A0	1FK2204-5AK...A0	1FK2204-6AF...A0
Static torque M_0	Nm (lb _F -ft)	1.27 (0.94)	1.27 (0.94)	2.4 (1.77)	2.4 (1.77)	3.2 (2.36)	2.4 (1.77)	2.4 (1.77)	3.2 (2.36)
Stall current I_0	A	1.19	2.4	2.1	4.4	3	2.25	4.4	3
Maximum torque M_{max}	Nm (lb _F -ft)	3.75 (2.77)	3.85 (2.84)	7.5 (5.53)	7.6 (5.61)	10 (7.38)	7.1 (5.24)	7.1 (5.24)	9.5 (7.01)
Maximum current I_{max}	A	4.2	8.7	7.6	16	10.9	7.1	14.2	9.9
Maximum speed n_{max}	rpm	7200	7500	6700	7100	7200	7500	7500	7600
Rotor moment of inertia J_{Mot}	kg cm ² (lb _F -in ²)	0.35 (0.120)	0.35 (0.120)	0.56 (0.191)	0.56 (0.191)	0.76 (0.260)	1.23 (0.420)	1.23 (0.420)	1.61 (0.550)
Moment of inertia (with brake) $J_{Mot Br}$	kg cm ² (lb _F -in ²)	0.43 (0.147)	0.43 (0.147)	0.65 (0.222)	0.65 (0.222)	0.84 (0.287)	1.31 (0.448)	1.31 (0.448)	1.69 (0.577)
Weight m_{Mot}	kg (lb)	2.05 (4.52)	2.05 (4.52)	2.85 (6.28)	2.85 (6.28)	3.4 (7.50)	2.9 (6.39)	2.9 (6.39)	3.5 (7.72)
Weight (with brake) $m_{Mot Br}$	kg (lb)	2.9 (6.39)	2.9 (6.39)	3.7 (8.16)	3.7 (8.16)	4.25 (9.37)	3.75 (8.27)	3.75 (8.27)	4.25 (9.37)
200 ... 240 V 1 AC / 3 AC									
Rated speed n_{rated}	rpm	–	3000	–	3000	–	–	3000	–
Rated torque M_{rated}	Nm (lb _F -ft)	–	1.27 (0.94)	–	2.4 (1.77)	–	–	2.4 (1.77)	–
Rated current I_{rated}	A	–	2.4	–	4.4	–	–	4.4	–
Rated power P_{rated}	W	–	400	–	750	–	–	750	–
Suitable for SINAMICS S210 servo converter		–	6SL3210-5HB10-4UF0	–	6SL3210-5HB10-8UF0	–	–	6SL3210-5HB10-8UF0	–
400 ... 480 V 3 AC									
Rated speed n_{rated}	rpm	3000	6000	3000	–	3000	3000	–	3000
Rated torque M_{rated}	Nm (lb _F -ft)	1.27 (0.94)	0.95 (0.70)	2.4 (1.77)	–	3.2 (2.36)	2.4 (1.77)	–	3.2 (2.36)
Rated current I_{rated}	A	1.19	1.88	2.1	–	3	2.25	–	3
Rated power P_{rated}	W	400	600	750	–	1000	750	–	1000
Suitable for SINAMICS S210 servo converter		6SL3210-5HE10-4UF0	6SL3210-5HE11-0UF0	6SL3210-5HE10-8UF0	–	6SL3210-5HE11-0UF0	6SL3210-5HE10-8UF0	–	6SL3210-5HE11-0UF0

Technical specifications (continued)

Dimensional drawing

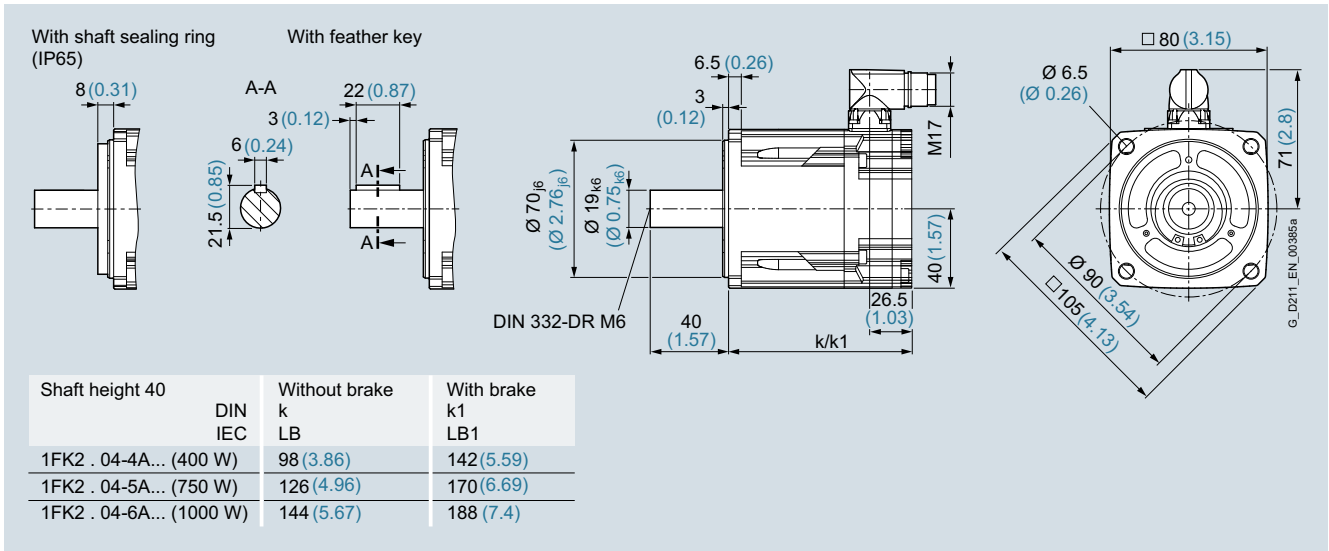

All dimensions in mm (values in brackets are in inches).

Speed/torque characteristics

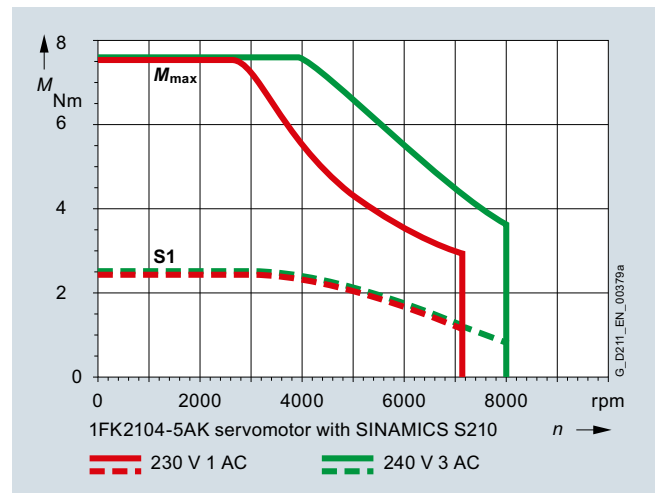
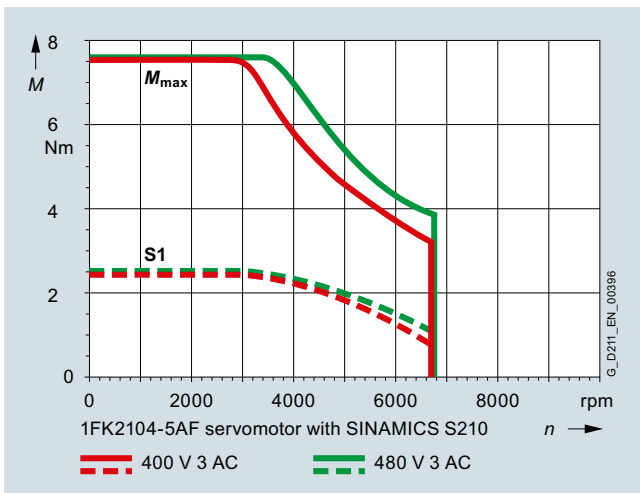
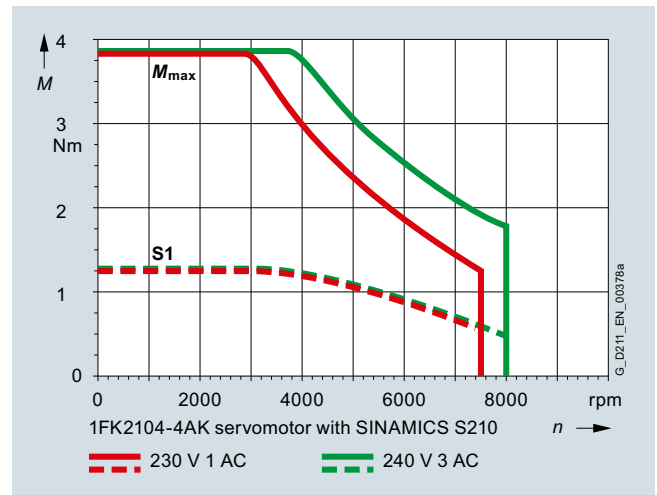
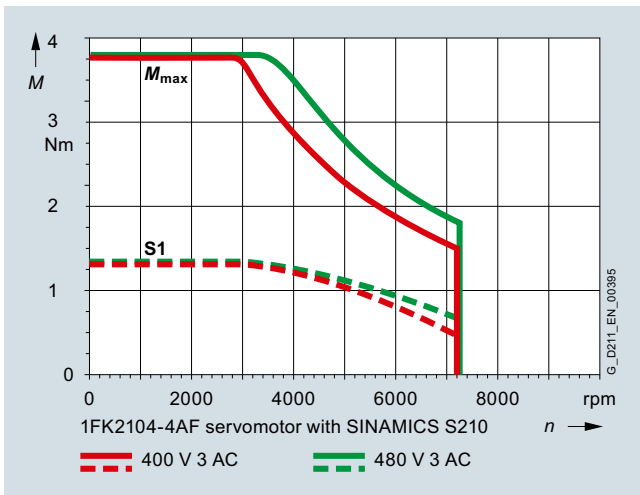

SIMOTICS S-1FK2 servomotors

SIMOTICS S-1FK2 servomotors for SINAMICS S210

Technical specifications (continued)

Speed/torque characteristics (continued)

3

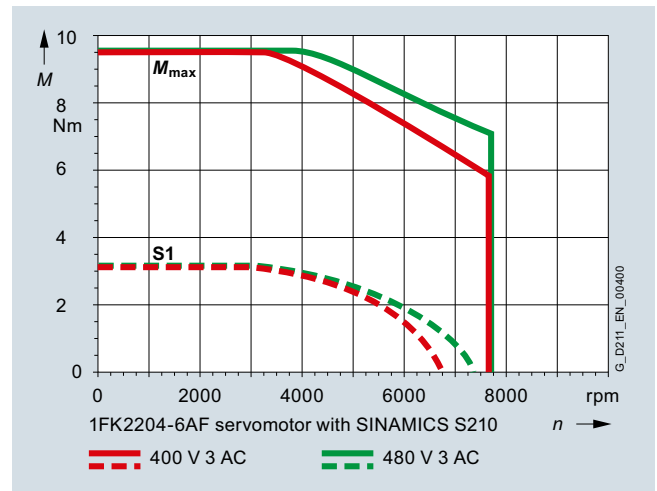
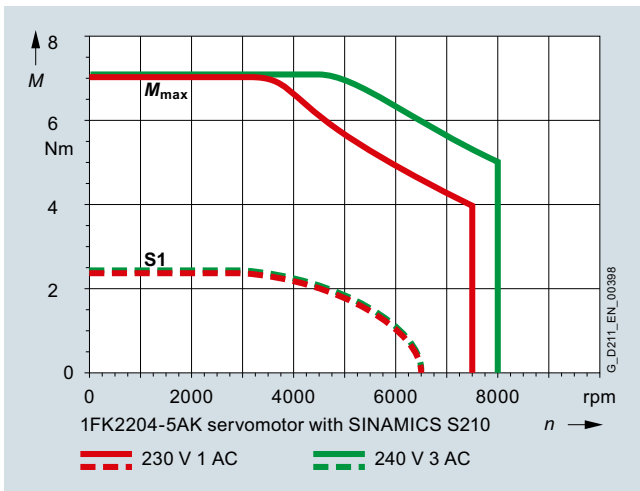
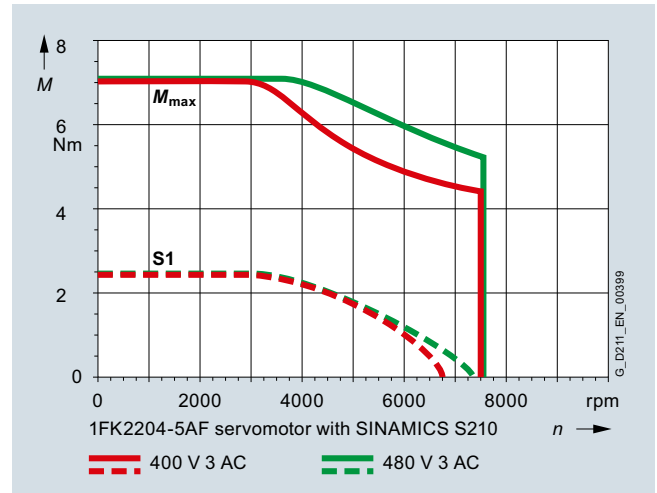
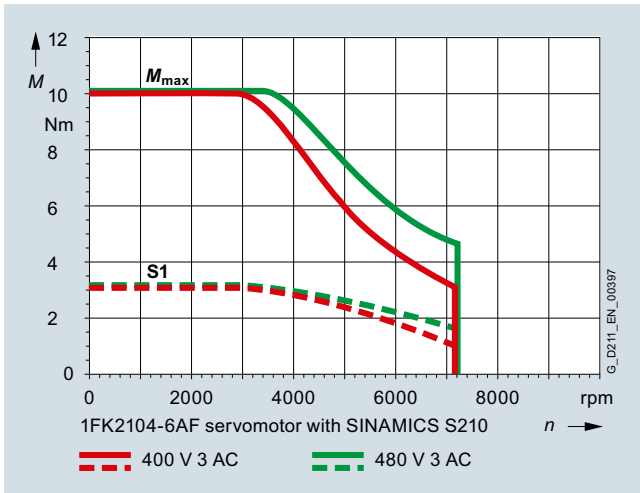

MOTION-CONNECT connection systems**4/2 MOTION-CONNECT connection systems**

- 4/2 Overview
- 4/2 Benefits
- 4/2 Application
- 4/2 Function
- 4/3 Characteristic curves
- 4/4 More information

4/5 One Cable Connection (OCC) technology for SINAMICS S210

- 4/5 Overview
- 4/5 Technical specifications
- 4/6 Selection and ordering data

Detailed technical information on the SINAMICS S210 servo drive system is available on the Internet at:
www.siemens.com/sinamics-s210/documentation

In addition, the Drive Technology Configurator (DT Configurator) can be used on the Internet at the following address:
www.siemens.com/dt-configurator

MOTION-CONNECT connection systems

MOTION-CONNECT connection systems

Overview

MOTION-CONNECT cables are suitable for use with many different types of machine tools and production machinery.

The following variants of MOTION-CONNECT cable are available as fully-assembled power and signal cables or sold by the meter:

- **MOTION-CONNECT 500**
 - Cost-effective solution for predominantly fixed installation
 - Suitable for low mechanical loading
 - Tested for travel distances up to 5 m (16.4 ft)
- **MOTION-CONNECT 800PLUS**
 - Meets requirements for use in cable carriers
 - Suitable for high mechanical loading
 - Oil resistance
 - Tested for travel distances of up to 50 m (164 ft)

Benefits

Pre-assembled MOTION-CONNECT cables provide high quality and impeccable system-tested functionality.

SPEED-CONNECT

Fast, stable and reliable connections can be made with the new, pre-assembled cables with SPEED-CONNECT connectors. With a short rotation as far as the stop, the cap nut of the connector secures the connection.

The cables with SPEED-CONNECT connectors supplement the previous offering of MOTION-CONNECT cables with full-thread connectors.

Application

MOTION-CONNECT cables are intended for use in machines. They are not suitable for building technology applications or outdoor installation.

MOTION-CONNECT cables have been tested in a cable carrier with horizontal travel distance and have also been designed for this type of application. They are not self-supporting.

The pre-assembled cables can be ordered in length units of 10 cm (3.94 in) and can be extended, if necessary.

When cable lengths (basic cables and extensions) are determined for the systems and applications described in this catalog, the technically permissible maximum cable lengths (e.g. 25 m (82 ft)) specified in the catalog must be observed. Malfunctions can occur if longer cables are used. Siemens assumes no liability for correct transmission of signals or power in this case.

Function

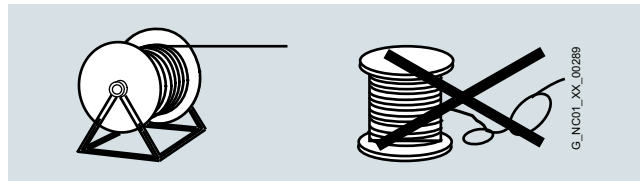

The cables must be removed from the drum without twisting, i.e., the cables must be unwound and must never be lifted over the drum flange in loops.

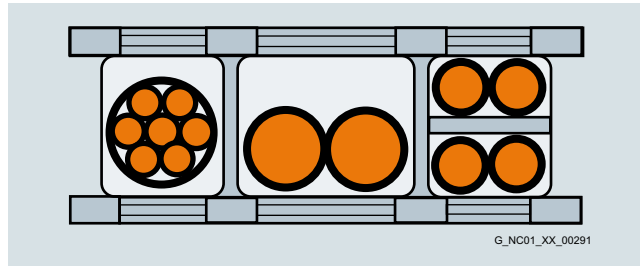

To maximize the service life of the cable carrier and cables, cables in the carrier made from different materials must be separated by spacers in the cable carrier. The spacers must be filled evenly to ensure that the position of the cables does not change during operation. The cables should be distributed as symmetrically as possible according to their weights and dimensions. Cables with very different outer diameters should also be separated by spacers.

When inserting pre-assembled cables into the cable carrier, do not pull at the connector, as this may damage the strain relief or cable clamping.

The cables must not be fixed in the cable carrier. They must be freely movable.

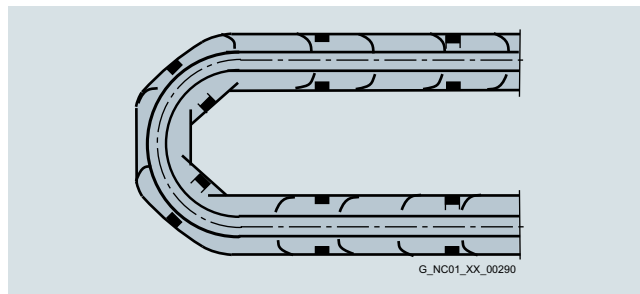

The cables must be able to be moved without applying force in particular in the bending radii of the carrier. The specified minimum bending radius must be adhered to.

Function (continued)

The cable fixings must be attached at both ends at an appropriate distance away from the end points of the moving parts in a dead zone.

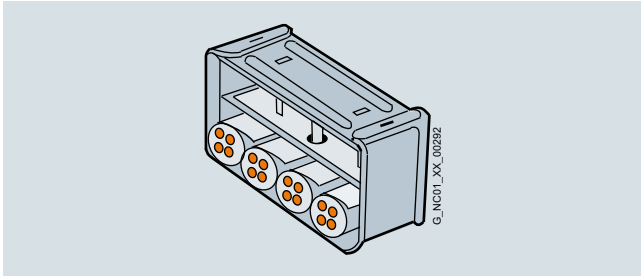

MOTION-CONNECT cables are tested in a cable carrier. The cables are attached at one end by means of strain relief to the moving ends of the cable carrier. Strain relief is applied over a wide area of the cable jacket surface without crimping the cable.

Cables must be installed in accordance with the instructions supplied by the cable carrier manufacturer.

Note:

If, for example, pre-assembled cables are installed in a cable carrier in such a way that the connector would inhibit assembly, pre-assembled cables without assembled connector can also be supplied (power and signal cables¹⁾). Depending on the version, the contacts of the cables are crimped and the connector is supplied separately. After installing the cables, the customer assembles the connector.

In case of vibration load and with horizontal or vertical cable entries, we recommend that the cable is additionally fixed if between the cable strain relief on the cable carrier and the terminal at the motor part of the cable is hanging loose or is not routed. To prevent machine vibrations being transmitted to the connectors, the cable should be fixed at the moving part where the motor is mounted.

Characteristic curves**Characteristic curves for MOTION-CONNECT 800PLUS**

The blue area beneath the characteristic curve represents the potential range of use for the cables. The characteristic curves represent the tested operating points.

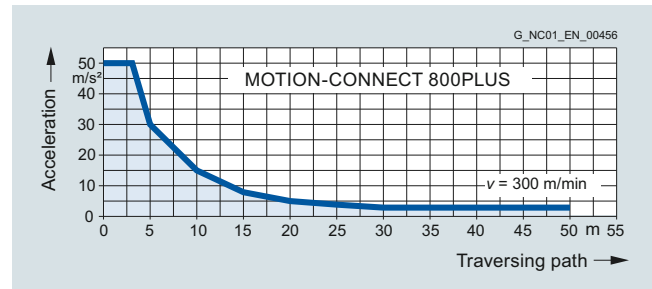

Permissible acceleration for MOTION-CONNECT 800PLUS signal and power cables up to 16 mm²

¹⁾ Not for DRIVE-CLiQ signal cables.

MOTION-CONNECT connection systems

MOTION-CONNECT connection systems

More information

Current carrying capacity for power and signal cables

The current carrying capacity of PVC/PUR-insulated copper cables is specified in the table for installation types B1, B2, C, and E under continuous operating conditions with reference to

an ambient air temperature of 40 °C (104 °F). For other ambient temperatures, the values must be corrected by the derating factors from the table.

Cross-section mm ²	Current carrying capacity rms AC 50/60 Hz or DC in amps for installation type			
	B1 Single-core cables in conduits or installation ducts	B2 Multi-core cables in conduits or installation ducts	C Multi-core cables, vertically or horizontally on walls/open, without conduits and installation ducts/ with contact	E Multi-core cables, horizontally or vertically on perforated cable racks/open, without conduits and installation ducts/ with contact
Electronics ¹⁾				
0.2	–	4.3	4.4	4.4
0.5	–	7.5	7.5	7.8
0.75	–	9	9.5	10
Power ²⁾				
0.38	6.2	6.1	7.1	7.4
0.75	8.6	8.5	9.8	10.4
1	10.3	10.1	11.7	12.4
1.5	13.5	13.1	15.2	16.1
2.5	18.3	17.4	21	22
4	24	23	28	30
6	31	30	36	37
10	44	40	50	52
16	59	54	66	70

Derating factors for power and signal cables

Ambient air temperature °C (°F)	Derating factor acc. to EN 60204-1, Table D.1
30 (86)	1.15
35 (95)	1.08
40 (104)	1
45 (113)	0.91
50 (122)	0.82
55 (131)	0.71
60 (140)	0.58

¹⁾ One control circuit pair.

²⁾ One symmetrically loaded three-phase AC cable.

Overview

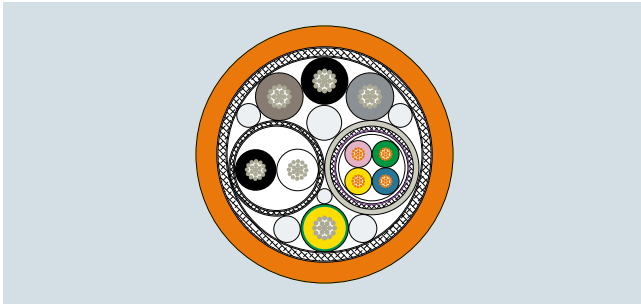

Motor and converter are simply connected to one another by one cable instead of the usual two or three cables. With this One Cable Technology, energy supply, encoder signals and braking signal are brought together in a single cable.

This results in the following advantages:

- Time-saving by laying only one cable
- Smaller installation space and space requirement in cable collars
- Only one cable has to be cleaned. This is advantageous, e.g. in the pharmaceutical industry and where higher requirements are placed upon hygiene
- Can be ordered to the decimeter
- M12 connection plug on the motor side (smallest OCC connector in the world), M17 connection plug (M23 available soon)
- Rotatable connectors on the motor side
- Motor with very low interfering contour for restricted installation space
- Bending radius optimized to $2.5 \times$ cable diameter static or $4 \times$ cable diameter dynamic for MOTION-CONNECT 800PLUS

Technical specifications



MOTION-CONNECT 500	6FX5002-8QN04-1...	6FX5002-8QN08-1...	6FX5002-8QN11-1...	6FX5002-8QN21-1...
Connector				
• Converter side	Siemens IX	Siemens IX	Siemens IX	Siemens IX
• Motor side	M12 (SPEED-CONNECT)	M17 (SPEED-CONNECT)	M23 (SPEED-CONNECT)	M23 (SPEED-CONNECT)
Number of cores	10	10	10	10
Cross-section	0.38 mm ²	0.75 mm ²	1.5 mm ²	2.5 mm ²
Cable length, max.	50 m (164 ft)	50 m (164 ft)	50 m (164 ft)	50 m (164 ft)
Cable structure	4G0.38+1Q0.2+1P0.38	4G0.75+1Q0.2+1P0.5	4G1.5+1Q0.2+1P1.5	4G2.5+1Q0.2+1P1.5
Max. number of bends	100000	100000	100000	100000
Number of disconnection points, max.	3 in 50 m (3 in 164 ft)	3 in 50 m (3 in 164 ft)	3 in 50 m (3 in 164 ft)	3 in 50 m (3 in 164 ft)
Degree of protection				
• Converter side	IP20	IP20	IP20	IP20
• Motor side	IP65	IP65	IP65	IP65
Certificates of suitability	RoHS, cURus, CE	RoHS, cURus, CE	RoHS, cURus, CE	RoHS, cURus, CE
Suitable for SIMOTICS S-1FK2 servomotor	1FK2102 and 1FK2 . 03	1FK2 . 04 and 1FK2 . 05	1FK2 . 06, 1FK2 . 08 and 1FK2 . 10	1FK2 . 06, 1FK2 . 08 and 1FK2 . 10
MOTION-CONNECT 800PLUS	6FX8002-8QN04-1...	6FX8002-8QN08-1...	6FX8002-8QN11-1...	6FX8002-8QN21-1...
Connector				
• Converter side	Siemens IX	Siemens IX	Siemens IX	Siemens IX
• Motor side	M12 (SPEED-CONNECT)	M17 (SPEED-CONNECT)	M23 (SPEED-CONNECT)	M23 (SPEED-CONNECT)
Number of cores	10	10	10	10
Cross-section	0.38 mm ²	0.75 mm ²	1.5 mm ²	2.5 mm ²
Cable length, max.	50 m (164 ft)	50 m (164 ft)	50 m (164 ft)	50 m (164 ft)
Cable structure	4G0.38+1Q0.2+1P0.38	4G0.75+1Q0.2+1P0.5	4G1.5+1Q0.2+1P1.5	4G2.5+1Q0.2+1P1.5
Max. number of bends	10 million	10 million	10 million	10 million
Number of disconnection points, max.	3 in 50 m (3 in 164 ft)	3 in 50 m (3 in 164 ft)	3 in 50 m (3 in 164 ft)	3 in 50 m (3 in 164 ft)
Degree of protection				
• Converter side	IP20	IP20	IP20	IP20
• Motor side	IP65	IP65	IP65	IP65
Certificates of suitability	RoHS, cURus, CE	RoHS, cURus, CE	RoHS, cURus, CE	RoHS, cURus, CE
Suitable for SIMOTICS S-1FK2 servomotor	1FK2102 and 1FK2 . 03	1FK2 . 04 and 1FK2 . 05	1FK2 . 06, 1FK2 . 08 and 1FK2 . 10	1FK2 . 06, 1FK2 . 08 and 1FK2 . 10

MOTION-CONNECT connection systems

One Cable Connection (OCC) technology for SINAMICS S210

Selection and ordering data

Motor connection cable

Design	Description	Connector size	Cross-section mm ²	D _{max} mm (in)	r _{static} mm (in)	r _{dynamic} mm (in)	For motor	Article No. (Length code see table)
	Pre-assembled OCC motor connection cable MOTION-CONNECT 500 for predominantly fixed routing With SPEED-CONNECT connector (shield connection clamp included in the scope of delivery)	M12	0.38	9.7 (0.38)	23.5 (0.93)	195 (7.68)	1FK2102, 1FK2 . 03	6FX5002-8QN04-1 ■■■■
		M17	0.75	10.5 (0.41)	25.5 (1.00)	195 (7.68)	1FK2 . 04, 1FK2 . 05	6FX5002-8QN08-1 ■■■■
		M23	1.5	12.7 (0.50)	30.7 (1.21)	195 (7.68)	1FK2 . 06, 1FK2 . 08, 1FK2 . 10	NEW 6FX5002-8QN11-1 ■■■■
		M23	2.5 ²⁾	13.7 (0.54)	30.7 (1.21)	195 (7.68)	1FK2 . 06, 1FK2 . 08, 1FK2 . 10	NEW 6FX5002-8QN21-1 ■■■■
	Pre-assembled OCC motor connection cable MOTION-CONNECT 800PLUS for use with cable carriers With SPEED-CONNECT connector (shield connection clamp included in the scope of delivery)	M12	0.38	9.7 (0.38)	28.2 (1.11)	38 (1.50)	1FK2102, 1FK2 . 03	6FX8002-8QN04-1 ■■■■
		M17	0.75	10.5 (0.41)	30.6 (1.20)	38 (1.50)	1FK2 . 04, 1FK2 . 05	6FX8002-8QN08-1 ■■■■
		M23	1.5	12.7 (0.50)	36.9 (1.45)	92.2 (3.63)	1FK2 . 06, 1FK2 . 08, 1FK2 . 10	NEW 6FX8002-8QN11-1 ■■■■
		M23	2.5 ²⁾	13.7 (0.54)	39.9 (1.57)	99.7 (3.93)	1FK2 . 06, 1FK2 . 08, 1FK2 . 10	NEW 6FX8002-8QN21-1 ■■■■
	OCC motor connection cable MOTION-CONNECT 500 for predominantly fixed routing With SPEED-CONNECT connector and with connector supplied on the converter side (shield connection clamp included in the scope of delivery) ¹⁾	M12	0.38	9.7 (0.38)	23.5 (0.93)	195 (7.68)	1FK2102, 1FK2 . 03	6FX5012-8QN04-1 ■■■■
		M17	0.75	10.5 (0.41)	25.5 (1.00)	195 (7.68)	1FK2 . 04, 1FK2 . 05	6FX5012-8QN08-1 ■■■■
		M23	1.5	12.7 (0.50)	30.7 (1.21)	195 (7.68)	1FK2 . 06, 1FK2 . 08, 1FK2 . 10	NEW 6FX5012-8QN11-1 ■■■■
		M23	2.5 ²⁾	13.7 (0.54)	30.7 (1.21)	195 (7.68)	1FK2 . 06, 1FK2 . 08, 1FK2 . 10	NEW 6FX5012-8QN21-1 ■■■■
	OCC motor connection cable MOTION-CONNECT 800PLUS for use with cable carriers With SPEED-CONNECT connector and with connector supplied on the converter side (shield connection clamp included in the scope of delivery) ¹⁾	M12	0.38	9.7 (0.38)	28.2 (1.11)	38 (1.50)	1FK2102, 1FK2 . 03	6FX8012-8QN04-1 ■■■■
		M17	0.75	10.5 (0.41)	30.6 (1.20)	38 (1.50)	1FK2 . 04, 1FK2 . 05	6FX8012-8QN08-1 ■■■■
		M23	1.5	12.7 (0.50)	36.9 (1.45)	92.2 (3.63)	1FK2 . 06, 1FK2 . 08, 1FK2 . 10	NEW 6FX8012-8QN11-1 ■■■■
		M23	2.5 ²⁾	13.7 (0.54)	39.9 (1.57)	99.7 (3.93)	1FK2 . 06, 1FK2 . 08, 1FK2 . 10	NEW 6FX8012-8QN21-1 ■■■■

Extension cable

Design	Description	Connector size	Cross-section mm ²	D _{max} mm (in)	r _{static} mm (in)	r _{dynamic} mm (in)	For motor	Article No. (Length code see table)
	Pre-assembled OCC extension cable MOTION-CONNECT 500 for predominantly fixed routing with SPEED-CONNECT connectors	M12	0.38	9.7 (0.38)	23.5 (0.93)	195 (7.68)	1FK2102, 1FK2 . 03	6FX5002-8QE04-1 ■■■■
		M17	0.75	10.5 (0.41)	25.5 (1.00)	195 (7.68)	1FK2 . 04, 1FK2 . 05	6FX5002-8QE08-1 ■■■■
		M23	1.5	12.7 (0.50)	30.7 (1.21)	195 (7.68)	1FK2 . 06, 1FK2 . 08, 1FK2 . 10	NEW 6FX5002-8QE11-1 ■■■■
		M23	2.5 ²⁾	13.7 (0.54)	30.7 (1.21)	195 (7.68)	1FK2 . 06, 1FK2 . 08, 1FK2 . 10	NEW 6FX5002-8QE21-1 ■■■■
	Pre-assembled OCC extension cable MOTION-CONNECT 800PLUS for use with cable carriers with SPEED-CONNECT connectors	M12	0.38	9.7 (0.38)	28.2 (1.11)	38 (1.50)	1FK2102, 1FK2 . 03	6FX8002-8QE04-1 ■■■■
		M17	0.75	10.5 (0.41)	30.6 (1.20)	38 (1.50)	1FK2 . 04, 1FK2 . 05	6FX8002-8QE08-1 ■■■■
		M23	1.5	12.7 (0.50)	36.9 (1.45)	92.2 (3.63)	1FK2 . 06, 1FK2 . 08, 1FK2 . 10	NEW 6FX8002-8QE11-1 ■■■■
		M23	2.5 ²⁾	13.7 (0.54)	39.9 (1.57)	99.7 (3.93)	1FK2 . 06, 1FK2 . 08, 1FK2 . 10	NEW 6FX8002-8QE21-1 ■■■■









¹⁾ Available soon.

²⁾ For increased requirement regarding routing type and ambient temperature.
See tables on page 4/4.

Selection and ordering data (continued)

Accessories

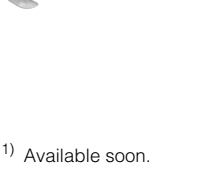
OCC components for customer assembly

Design	Description	Cross-section mm ²	For motor	Article No. (Length code see table)
	Sold by the meter, OCC line MOTION-CONNECT 500 For the self-assembly of motor connection or extension cables MOTION-CONNECT 500 predominantly for fixed routing (see table for length codes) ¹⁾	0.38	1FK2102, 1FK2 . 03	6FX5008-1BE04-1■■■■
		0.75	1FK2 . 04, 1FK2 . 05	6FX5008-1BE08-1■■■■
		1.5	1FK2 . 06, NEW 1FK2 . 08, 1FK2 . 10	6FX5008-1BE11-1■■■■
		2.5 ²⁾	1FK2 . 06, NEW 1FK2 . 08, 1FK2 . 10	6FX5008-1BE21-1■■■■
	Sold by the meter, OCC line MOTION-CONNECT 800PLUS For the self-assembly of motor connection or extension cables MOTION-CONNECT 800PLUS for use with cable carriers (see table for length codes) ¹⁾	0.38	1FK2102, 1FK2 . 03	6FX8008-1BE04-1■■■■
		0.75	1FK2 . 04, 1FK2 . 05	6FX8008-1BE08-1■■■■
		1.5	1FK2 . 06, NEW 1FK2 . 08, 1FK2 . 10	6FX8008-1BE11-1■■■■
		2.5 ²⁾	1FK2 . 06, NEW 1FK2 . 08, 1FK2 . 10	6FX8008-1BE21-1■■■■
	Motor-side M12 SPEED-CONNECT connector 10-pole, including all socket contacts ¹⁾	0.38	1FK2102, 1FK2 . 03	6FX2003-0LU64
	Motor-side M17 SPEED-CONNECT connector 10-pole, including all socket contacts ¹⁾	0.75	1FK2 . 04, 1FK2 . 05	6FX2003-0LU54
	Motor-side M23 SPEED-CONNECT connector 10-pole, including all socket contacts ¹⁾	1.5 and 2.5	1FK2 . 06, NEW 1FK2 . 08, 1FK2 . 10	6FX2003-0LU34
	M12 SPEED-CONNECT connector with external thread for extension cable 10-pole, including all pin contacts ¹⁾	0.38	1FK2102, 1FK2 . 03	6FX2003-0LA64
	M17 SPEED-CONNECT connector with external thread for extension cable 10-pole, including all pin contacts ¹⁾	0.75	1FK2 . 04, 1FK2 . 05	6FX2003-0LA54
	M23 SPEED-CONNECT connector with external thread for extension cable 10-pole, including all pin contacts ¹⁾	1.5 and 2.5	1FK2 . 06, NEW 1FK2 . 08, 1FK2 . 10	6FX2003-0LA34
	Converter-side Siemens IX signal connector Device version in insulation displacement technology for field assembly ¹⁾	–	–	6FX2003-0DE01
	Shield clamp For attaching the connection cables to the shield plate of the converter (packing unit 10 items) • For pre-assembled cables with M12 and M17 connectors • For pre-assembled cables with M23 connectors ¹⁾	–	–	6FX2003-7EX10 NEW 6FX2003-7EX11

¹⁾ Available soon.²⁾ For increased requirement regarding routing type and ambient temperature. See tables on page 4/4.

MOTION-CONNECT connection systems

One Cable Connection (OCC) technology for SINAMICS S210

Selection and ordering data (continued)

Control cabinet bushing

Design	Description	Article No.
	Mounting flange For cabinet bushing <ul style="list-style-type: none"> • For connector size M12 • For connector size M17 • For connector size M23 NEW 	6FX2003-7JX00 6FX2003-7HX00 6FX2003-7BX00

Length code (max. 50 m (164 ft))

Description	Article No. supplement
MOTION-CONNECT cable	6FX . 0 . 2-8Q . 0 . -1
0 m (0 ft)	A
10 m (32.8 ft)	B
20 m (65.6 ft)	C
30 m (98.4 ft)	D
40 m (131 ft)	E
50 m (164 ft)	F
0 m (0 ft)	A
1 m (3.28 ft)	B
2 m (6.56 ft)	C
3 m (9.84 ft)	D
4 m (13.1 ft)	E
5 m (16.4 ft)	F
6 m (19.7 ft)	G
7 m (23.0 ft)	H
8 m (26.2 ft)	J
9 m (29.5 ft)	K
0 m (0 ft)	0
0.1 m (0.33 ft)	1
0.2 m (0.66 ft)	2
0.3 m (0.98 ft)	3
0.4 m (1.31 ft)	4
0.5 m (1.64 ft)	5
0.6 m (1.97 ft)	6
0.7 m (2.30 ft)	7
0.8 m (2.62 ft)	8

Engineering tools

**Security information**

Siemens provides products and solutions with industrial security functions that support the secure operation of plants, systems, machines and networks.

In order to protect plants, systems, machines and networks against cyber threats, it is necessary to implement – and continuously maintain – a holistic, state-of-the-art industrial security concept. Siemens' products and solutions constitute one element of such a concept.

Customers are responsible for preventing unauthorized access to their plants, systems, machines and networks.

Such systems, machines and components should only be connected to an enterprise network or the internet if and to the extent such a connection is necessary and only when appropriate security measures (e.g. firewalls and/or network segmentation) are in place.

For additional information on industrial security measures that may be implemented, please visit

<https://www.siemens.com/industrialsecurity>

Siemens' products and solutions undergo continuous development to make them more secure. Siemens strongly recommends that product updates are applied as soon as they are available and that the latest product versions are used. Use of product versions that are no longer supported, and failure to apply the latest updates may increase customer's exposure to cyber threats.

To stay informed about product updates, subscribe to the Siemens Industrial Security RSS Feed under

<https://www.siemens.com/industrialsecurity>

5/2	Drive Technology Configurator
5/3	TIA Selection Tool
5/4	SINAMICS Web server for SINAMICS S210
5/5	SINAMICS Startdrive commissioning tool

Engineering tools

Drive Technology Configurator

Overview

The Drive Technology Configurator (DT Configurator) helps you to configure the optimum drive technology products for your application – starting with gear units, motors, converters as well as the associated options and components and ending with controllers, software licenses and connection systems. Whether with little or detailed knowledge of products: preselected product groups, deliberate navigation through selection menus and direct product selection through entry of the article number support quick, efficient and convenient configuration.

In addition, comprehensive documentation comprising technical data sheets, 2D dimensional drawings/3D CAD models, operating instructions, certificates, etc. can be selected in the DT Configurator. Immediate ordering is possible by simply transferring a parts list to the shopping cart of the Industry Mall.

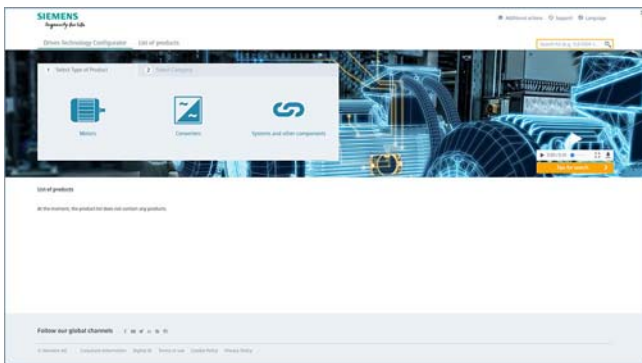

Drive Technology Configurator for efficient drive configuration with the following functions

- Quick and easy configuration of drive products and associated components – gear units, motors, converters, controllers, connection systems
- Configuration of drive systems for pump, fan and compressor applications from 1 kW to 2.6 MW
- Retrievable documentation for configured products and components, such as
 - Data sheets in up to 9 languages in PDF or RTF format
 - 2D dimensional drawings/3D CAD models in various formats
 - Terminal box drawing and terminal connection diagram
 - Operating instructions
 - Certificates
 - Start-up calculation for SIMOTICS motors
 - EPLAN macros
- Support with retrofitting in conjunction with Spares On Web www.siemens.com/sow
- Ability to order products directly through the Siemens Industry Mall

Access to the Drive Technology Configurator

The Drive Technology Configurator can be called up without registration and without a login:

www.siemens.com/dt-configurator

Selection and ordering data

Description	Article No.
Interactive Catalog CA 01 Including Drive Technology Configurator <ul style="list-style-type: none"> • German (DVD-ROM – Germany edition) • German, English, French, Spanish (download – without prices) 	E86060-D4001-A500-D9 www.siemens.com/automation/ca01

More information

Online access to the Drive Technology Configurator

More information about the Drive Technology Configurator is available on the Internet at www.siemens.com/dtconfigurator

Offline access to the Drive Technology Configurator in the Interactive Catalog CA 01

In addition, the Drive Technology Configurator is also included in the Interactive Catalog CA 01 – the offline version of the Siemens Industry Mall.

The Interactive Catalog CA 01 can be ordered from the relevant Siemens sales office or via the Internet: www.siemens.com/automation/CA01

Overview

Selection guide and configurator for automation technology

Error-free configuration without expert knowledge through intelligent configurators and selection wizards. Desktop and cloud versions enable cross-team collaboration with maximum flexibility.

There are two versions of the TIA Selection Tool:

- One for downloading and execution on Windows PCs (from Microsoft Windows 7)
- One for running from the cloud, which is launched from mobile devices directly in the browser (we recommend Safari, Chrome and Firefox)

Projects stored in the cloud can be edited with both tools. This makes it possible to work on-the-go using a tablet, at home on a PC – and vice versa, or together with colleagues and customers.

In order to use the full functionality, we recommended setting up a Siemens Industry Mall account for both cases. This gives you access to prices and enables you to save your projects to our cloud.

You can find additional information about the TIA Selection Tool at:

www.siemens.com/tia-selection-tool

Engineering tools

SINAMICS Web server for SINAMICS S210

Overview

Web server for efficient commissioning, diagnostics and maintenance – available anywhere, anytime

Thanks to the web server, the SINAMICS S210 drive system offers efficient commissioning, diagnostics and maintenance options. The web server provides access to a multi-faceted range of new options for parameter assignment, drive diagnostics and remote maintenance for any networked PC with a web browser or for tablets and smartphones (via a separate WLAN access point), including:

- Simple and fast commissioning
- Drive traversing via the control panel
- Downloading/uploading a configuration
- Providing a status overview of the drive
- Evaluating warnings and fault messages
- Monitoring and adapting parameter setting

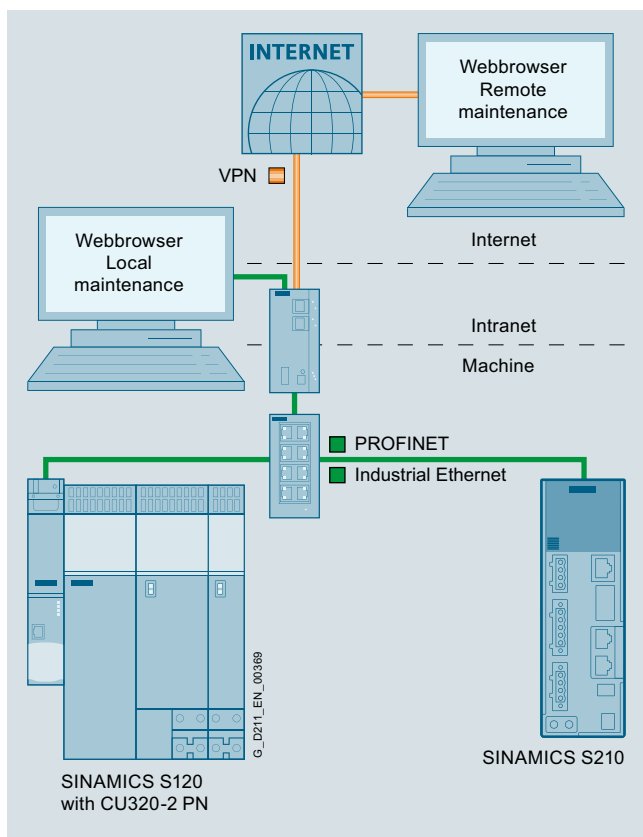

Integration of the SINAMICS web server as shown by the example of SINAMICS S120, SINAMICS S210 and PROFINET communication

The SINAMICS web server is available as of SINAMICS S210 firmware V5.1.

Benefits

Simple and fast commissioning

- No installation of additional commissioning software
- Simple controller optimization with One Button Tuning
- Easy parameterization of Safety Integrated Functions
- Standard pages for limit values and settings
- Comprehensive fault diagnosis
- Firmware update

Shorter machine downtimes

- Efficient diagnostics and maintenance

Direct language selection

- English, French, German, Italian, Spanish, Chinese Simplified

Accessibility

- Via all LAN or PROFINET interfaces
- Tablet and smartphone access via WLAN with separate access point

Two users with different rights profiles

- e.g. for operators and service personnel

Diagnostic functions

- Quick overview of the current configuration and the state of the drive
- Understandable diagnostic information and messages, including the causes of issues and possible remedies, are displayed in plain text in multiple languages

Freely configurable parameter lists

- Monitoring parameters for diagnostic purposes, for example for operating personnel
- Adjustment of the parameter lists using filters, parameter groups and the configuration of personal lists

Access security

- Protection against unauthorized access to the drive information

Application

The web server is ideal for applications in which special commissioning software or version dependencies are not desired. Easy commissioning, diagnostics and maintenance are possible both locally and remotely, provided appropriate security measures are applied.

Overview

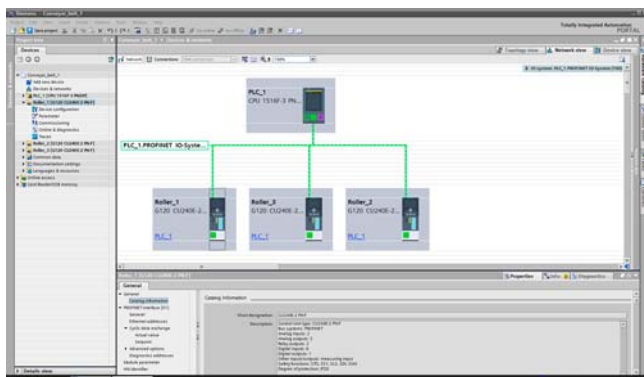

SINAMICS Startdrive is a tool for configuring, commissioning, and diagnosing the SINAMICS converter family and is integrated into the TIA Portal.

The SINAMICS Startdrive commissioning tool has been optimized with regard to user friendliness and consistent use of the TIA Portal benefits of a common working environment for PLC, HMI and drives.

Performance features

Efficient commissioning with easy configuration and powerful tools:

- High degree of usability thanks to task-based navigation through the engineering workflow
 - Hardware configuration
 - Parameterization
 - Commissioning
 - Diagnostics
- Time-saving and guided step-by-step commissioning (only for SINAMICS G)
- User-friendly graphic function view for all drive functions
- List of drive parameters structured according to functions
- Easy integration of SIMOTICS motors
- Integrated control panel for direct operation of the converter from the TIA Portal
- Powerful realtime trace for commissioning and drive diagnostics
- Intuitive and efficient drive diagnostics through automatic display of messages
- Context-sensitive online help, e.g. for drive messages
- Integrated detailed drive diagnostic functions
 - Control/status words
 - Parameter status
 - Operating conditions
 - Communication states
- Simple configuration for drive-end Safety Integrated
- Drive-internal basic positioning function (EPos, not for SINAMICS S210)
- Support of One Button Tuning for the simplest optimization of the drive (only for SINAMICS S)
- Integrated safety acceptance test to facilitate the required documentation

Integration

Integration of the SINAMICS converter family with SIMATIC in the TIA Portal

The software packages based on the TIA Portal are harmonized with each other and offer important benefits. The TIA Portal enables simple integration of SINAMICS converters in your automation solution:

- Reduction in training costs thanks to cross-tool uniformity of the operator inputs
- Device configuration and network connection of the converters in the TIA Portal-wide configuration/network editor
- Device access to the drives via the PLC across network boundaries (dataset routing)
- Automatic frame comparison between converters and SIMATIC S7 PLC
- Reduction of standstill times through the integration of converter messages in the SIMATIC S7 system diagnostics:
 - The drive messages are part of the SIMATIC S7 system diagnostics without previous configuration effort
 - The drive messages are therefore automatically available as plain text in the TIA Portal, the web server of the SIMATIC S7 PLC and the HMI
- Time savings thanks to simple and guided configuration of the drives for operation with SIMATIC S7 Motion Control
- Short familiarization time for SIMATIC STEP 7 users due to common use of editors. Realtime trace and the drive control panel are identical to the editors in STEP 7
- Reuse of the drive configuration and parameterization is possible with the assistance of the TIA Portal library
- Standard TIA Portal functions for converters, e.g. Undo, Redo
- Block library supplied for easy integration of SINAMICS drives into the user programs of the SIMATIC S7-300, S7-400, S7-1200, S7-1500
 - SINAMICS G120: Control Unit and Power Module supported with EPLAN V2.8
 - SINAMICS S120: Control Unit only
- Shared project storage for all devices in the project
- Use of the Openness interface for remote control of the TIA Portal with external applications
- Generation of a TIA Portal project by an AML-based import from EPLAN or data import/export from/to EPLAN
 - SINAMICS G120: Control Unit and Power Module supported with EPLAN V2.8
 - SINAMICS S120: Control Unit only

Supported frequency converters

The following frequency converters can be configured with SINAMICS Startdrive

- SINAMICS V90
- SINAMICS G120
- SINAMICS G120C
- SINAMICS G120D
- SINAMICS G120P
- SINAMICS G110M
- SINAMICS G130
- SINAMICS G150
- SINAMICS S120
- SINAMICS S150
- SINAMICS S210
- SINAMICS medium voltage converters

All of the available Control Units with SINAMICS Firmware V4.4 and later are supported for the SINAMICS G120, G120C, G120D, G120P and G110M devices (including PROFINET, PROFIBUS, Safety Integrated). All combinable Power Modules up to 400 kW can be configured.

Control Unit CU320-2 PN from SINAMICS Firmware V4.8 is supported for the SINAMICS S120, G130, G150, S150 devices and for the SINAMICS medium voltage converters.

SINAMICS S210 is supported from firmware V5.2.

Engineering tools

SINAMICS Startdrive commissioning tool

Integration (continued)

SINAMICS Startdrive Advanced

- Advanced functions for SINAMICS Startdrive V15.1:
 - Safety acceptance test for the SINAMICS G120 family, SINAMICS S120 and SINAMICS S210
 - Prompted acceptance test wizard for all drive-based Safety Integrated Functions (Basic and Extended Safety)
 - Automatic and safety function-specific generation of traces to analyze the machine behavior
 - Generation of an acceptance report as Excel file (xlsx format, can also be used with OpenOffice)
 - Available for SINAMICS G110M, G120, G120C, G120D, G120P, S120 and S210
- Also contains all Startdrive Basic functions
- Only a license key is required, no additional installation
- A trial license is available free-of-charge without a license key (21 days)

Installation versions

SINAMICS Startdrive can be installed as an optional package to SIMATIC STEP 7 or as a stand-alone application (without SIMATIC STEP 7).

System requirements

The following table shows the recommended hardware and system equipment for the operation of SINAMICS Startdrive.

Hardware	Recommendation
Computer	As of SIMATIC FIELD PG M5 Advanced (or comparable PC)
Processor	Intel Core i5-6440EQ (up to 3.4 GHz)
RAM	16 GB or more (32 GB for large projects)
Hard disk	SSD with at least 50 GB available memory
Screen resolution	15.6" Full HD display (1920 × 1080 or larger)
Operating systems	<ul style="list-style-type: none"> Windows 7 (64 bit) <ul style="list-style-type: none"> Windows 7 Professional SP1 Windows 7 Enterprise SP1 Windows 7 Ultimate SP1 Windows 10 (64 bit) <ul style="list-style-type: none"> Windows 10 Professional Version 1703 Windows 10 Enterprise Version 1703 Windows 10 Enterprise 2016 LTSC Windows 10 IoT Enterprise 2015 LTSC Windows 10 IoT Enterprise 2016 LTSC Windows Server (64 bit) <ul style="list-style-type: none"> Windows Server 2012 R2 StdE (full installation) Windows Server 2016 Standard (full installation)

Compatibility with other products

- Startdrive V15.1 operates with STEP 7, WinCC and Scout TIA V15 in one framework
- Startdrive V15.1 can be installed on the same computer as other versions of Startdrive V12 to V14 SP1
- Startdrive can be installed on the same computer as SINAMICS MICROMASTER STARTER

Integration (continued)

Supported virtualization platforms

SINAMICS Startdrive can be installed in a virtual machine. For this purpose, one of the following virtualization platforms in the specified version or a newer version can be used:

- VMware vSphere Hypervisor (ESXi) 6.5
- VMware Workstation 12.5.5
- VMware Player 12.5.5
- Microsoft Hyper-V Server 2016

Supported security programs

The following security programs have been tested with SINAMICS Startdrive V15.1:

- Virus scanners:
 - Symantec Endpoint Protection 14
 - Trend Micro OfficeScan Corporate Edition 12.0/XGen
 - McAfee Endpoint Security 10.x
 - Kaspersky Anti-Virus 2018
 - Windows Defender
 - Qihoo 360 „Safe Guard 11.4“ + „Virus Scanner 5.0“
- Encryption software:
 - Microsoft Bitlocker
- Host-based Intrusion Detection System
 - McAfee Application Control 8.0

Selection and ordering data

Description	Article No.
SINAMICS Startdrive Basic V15.1 commissioning tool Single license and certificate of license English, French, German, Italian, Spanish, Chinese Simplified <ul style="list-style-type: none"> On DVD-ROM NEW On the Internet as a download NEW 	6SL3072-4FA02-0XA0 6SL3072-4FA02-0XG0
SINAMICS Startdrive Advanced V15.1 commissioning tool License key (floating license) English, French, German, Italian, Spanish, Chinese Simplified <ul style="list-style-type: none"> On DVD-ROM with license key on USB flash drive NEW On the Internet as a download NEW 	6SL3072-4FA02-0XA5 6SL3072-4FA02-0XG5

More information

The SINAMICS Startdrive Basic commissioning tool is available free on the Internet at www.siemens.com/startdrive

Services and documentation

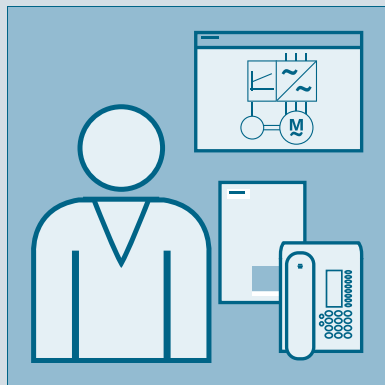

6/2	Partner
6/3	Industry Services
6/4	Industry Services – Portfolio overview
6/5	Online Support
6/6	Training
6/6	SITRAIN – Digital Industry Academy
6/7	SINAMICS S210 training case
6/8	Applications
6/9	Drives Options Partner
6/10	mySupport documentation
6/11	Documentation
6/12	General documentation
6/12	SINAMICS S210 documentation

Services and documentation

Partner

Partner at Siemens

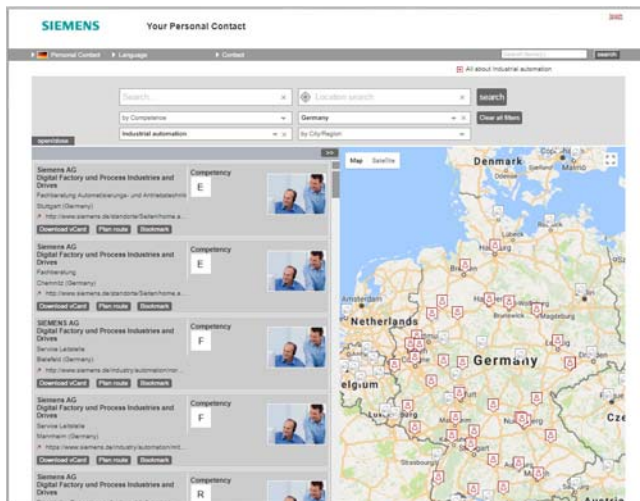

At your service locally, around the globe for consulting, sales, training, service, support, spare parts on the entire portfolio of Digital Industries.

Your partner can be found in our Personal Contacts Database at: www.siemens.com/automation-contact

You start by selecting

- the required competence,
- products and branches,
- a country and a city

or by a

- location search or free text search.

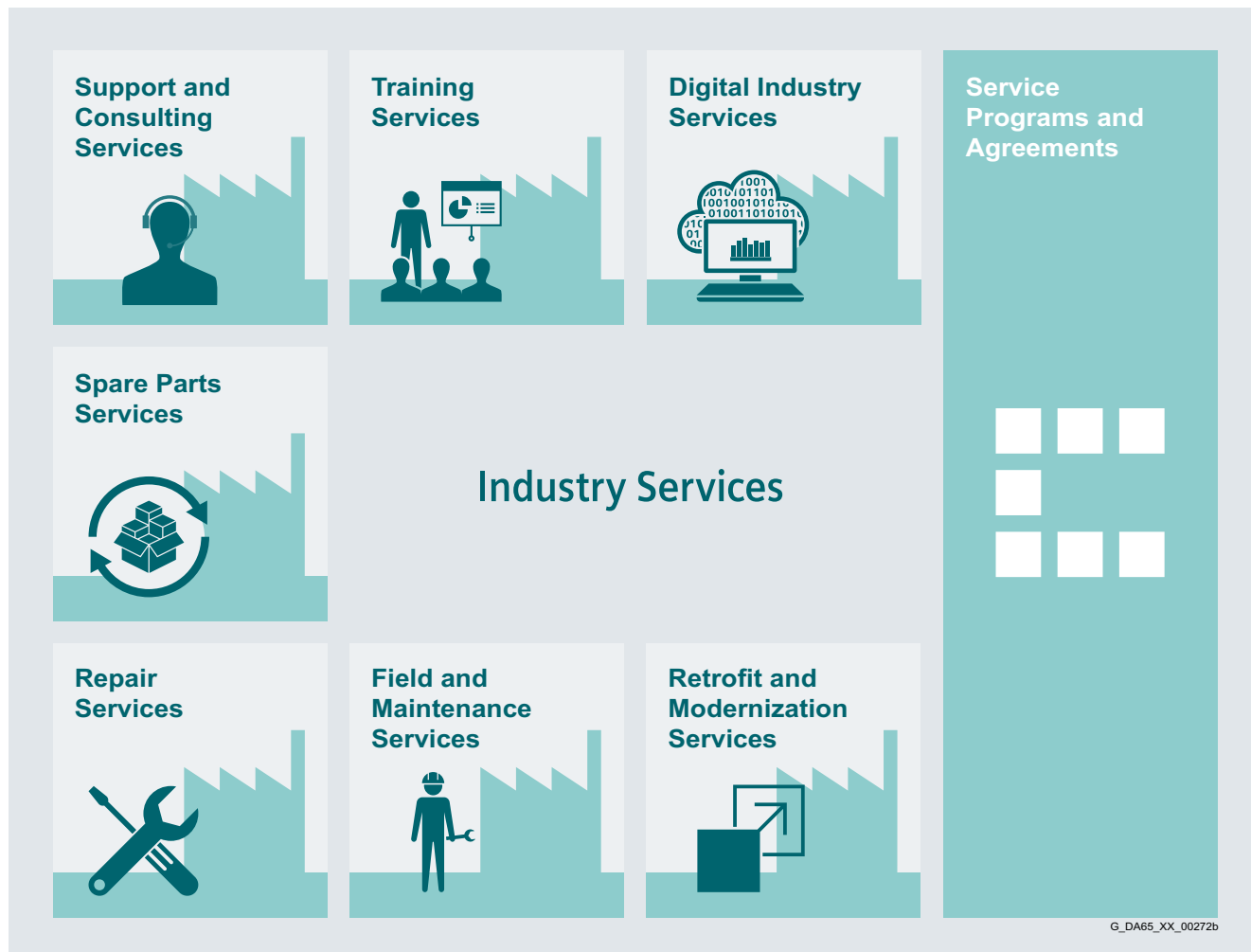
Overview

Keep your business running and shaping your digital future – with Industry Services

Optimizing the productivity of your equipment and operations can be a challenge, especially with constantly changing market conditions. Working with our service experts makes it easier. We understand your industry's unique processes and provide the services needed so that you can better achieve your business goals.

You can count on us to maximize your uptime and minimize your downtime, increasing your operations' productivity and reliability. When your operations have to be changed quickly to meet a new demand or business opportunity, our services give you the flexibility to adapt. Of course, we take care that your production is protected against cyber threats. We assist in keeping your operations as energy and resource efficient as possible and reducing your total cost of ownership. As a trendsetter, we ensure that you can capitalize on the opportunities of digitalization and by applying data analytics to enhance decision making: You can be sure that your plant reaches its full potential and retains this over the longer lifespan.

You can rely on our highly dedicated team of engineers, technicians and specialists to deliver the services you need – safely, professionally and in compliance with all regulations. We are there for you, where you need us, when you need us.

www.siemens.com/industryservices

Services and documentation

Industry Services

Industry Services – Portfolio overview

Overview



Digital Industry Services

Digital Industry Services

Digital Industry Services make your industrial processes transparent to gain improvements in productivity, asset availability, and energy efficiency.

Production data is generated, filtered and translated with intelligent analytics to enhance decision-making.

This is done whilst taking data security into consideration and with continuous protection against cyber-attack threats.

<https://www.siemens.com/global/en/home/products/services/industry/digital-services.html>

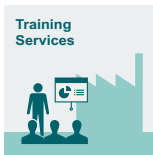

Training Services

Training Services

From the basics and advanced to specialist skills, SITRAIN courses provide expertise right from the manufacturer – and encompass the entire spectrum of Siemens products and systems for the industry.

Worldwide, SITRAIN courses are available wherever you need a training course in more than 170 locations in over 60 countries.

<https://support.industry.siemens.com/cs/ww/en/sc/2226>

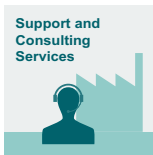

Support and Consulting Services

Support and Consulting Services

Industry Online Support site for comprehensive information, application examples, FAQs and support requests.

Technical and Engineering Support for advice and answers for all inquiries about functionality, handling, and fault clearance. The Service Card as prepaid support for value added services such as Priority Call Back or Extended Support offers the clear advantage of quick and easy purchasing.

Information & Consulting Services, e.g. SIMATIC System Audit; clarity about the state and service capability of your automation system or Lifecycle Information Services; transparency on the lifecycle of the products in your plants.

<https://support.industry.siemens.com/cs/ww/en/sc/2235>



Spare Parts Services

Spare Parts

Spare Parts Services are available worldwide for smooth and fast supply of spare parts – and thus optimal plant availability. Genuine spare parts are available for up to ten years. Logistic experts take care of procurement, transport, custom clearance, storage and order management.

Reliable logistics processes ensure that components reach their destination as needed.

Since not all spare parts can be kept in stock at all times, Siemens offers a preventive measure for spare parts provisioning on the customer's premises with optimized **Spare Parts Packages** for individual products, custom-assembled drive components and entire integrated drive trains – including risk consulting.

Asset Optimization Services help you design a strategy for parts supply where your investment and carrying costs are reduced and the risk of obsolescence is avoided.

<https://support.industry.siemens.com/cs/ww/en/sc/2110>



Repair Services

Repair Services

Repair Services are offered on-site and in regional repair centers for fast restoration of faulty devices' functionality.

Also available are extended repair services, which include additional diagnostic and repair measures, as well as emergency services.

<https://support.industry.siemens.com/cs/ww/en/sc/2154>

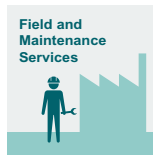

Field and Maintenance Services

Field and Maintenance Services

Siemens specialists are available globally to provide expert field and maintenance services, including commissioning, functional testing, preventive maintenance and fault clearance.

All services can be included in customized service agreements with defined reaction times or fixed maintenance intervals.

<https://support.industry.siemens.com/cs/ww/en/sc/2265>



Retrofit and Modernization Services

Retrofit and Modernization Services

Provide a cost-effective solution for the expansion of entire plants, optimization of systems or upgrading existing products to the latest technology and software, e.g. migration services for automation systems.

Service experts support projects from planning through commissioning and, if desired over the entire extended lifespan, e.g. Retrofit for Integrated Drive Systems for an extended lifetime of your machines and plants.

<https://support.industry.siemens.com/cs/ww/en/sc/2286>



Service Programs and Agreements

Service Programs and Agreements

A technical Service Program or Agreement enables you to easily bundle a wide range of services into a single annual or multi-year agreement.

You pick the services you need to match your unique requirements or fill gaps in your organization's maintenance capabilities.

Programs and agreements can be customized as KPI-based and/or performance-based contracts.

<https://support.industry.siemens.com/cs/ww/en/sc/2275>

Overview

Online Support – fast, intuitive, whenever you want, wherever you need

Web
support.industry.siemens.com

App

Get it on Google Play | Get it on the App Store | Download on the Microsoft Store

Scan the QR code for information on our Online Support app.

FAQ / Application examples
Information about industrial products, programming and configuration as well as application examples

Technical information
Videos, documentation, manuals, updates, product notes, compatibility tool, certificates, planning data such as dimensional drawings, product data, 3D models

Forum
Exchange information and experience with other users and experts

Online Support for Siemens Industry Products

Siemens Industry and Online Support with some 1.7 million visitors per month is one of the most popular web services provided by Siemens. It is the central access point for comprehensive technical know-how about products, systems and services for automation and drives applications as well as for process industries.

In connection with the challenges and opportunities related to digitalization you can look forward to continued support with innovative offerings.

Services and documentation

Training

SITRAIN – Digital Industry Academy

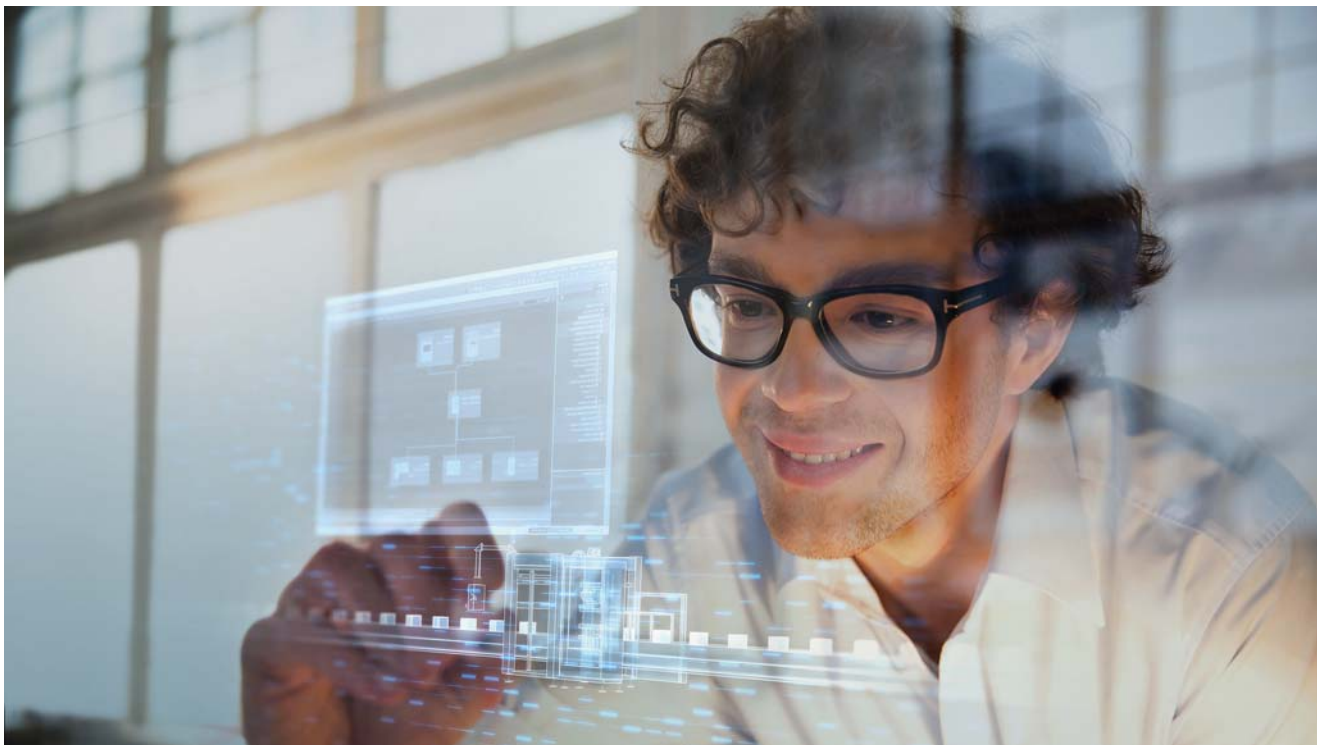

Time for learning

Today's demands on our knowledge are every bit as diverse and dynamic as our profession itself. We keep learning more and longer – for our work, for our career and for ourselves. Advancing digitalization entails new topics and is also changing the way we absorb and process knowledge. SITRAIN – Digital Industry Academy offers the right source of knowledge here, which we can use anytime in just the way we need it. The time for learning is now.

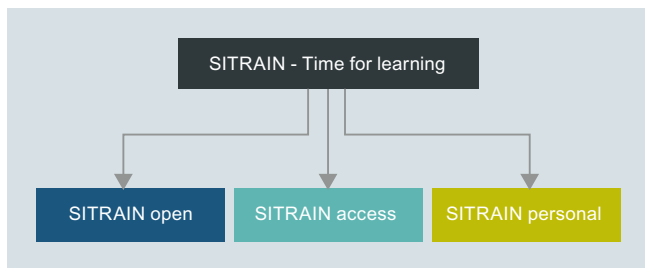

Knowledge for every need

With its three areas – SITRAIN open, SITRAIN access and SITRAIN personal – SITRAIN offers you an all-encompassing range of options for an ongoing expansion of your knowledge and skills, suited for every type of learner. And SITRAIN uses advancing digitalization to continuously expand content and offer new training methods.

Knowledge you can always find

SITRAIN open bundles useful information, worthwhile data and up-to-date expert knowledge about Siemens products for industry. Search it anytime, find anything – and always the right stuff.

Knowledge that gets you ahead

SITRAIN access is learning in the digital age. It offers you individualized ways to build your knowledge and access to exclusive digital training courses. Take advantage of sustainable learning success with a wide range of learning methods. Improve your skills – whether working in groups with others, or by yourself. Whenever, wherever and however you need to.

Knowledge you can experience

We all want to learn from the best. And SITRAIN personal's training courses let you benefit from our well-practiced trainers' expert knowledge, along with direct access to our training equipment. That's the best way to convey knowledge – whether at your company or in our training classrooms.

Find
your local
offer here



SITRAIN – Digital Industry Academy
Customer Support Germany

Tel.: +49 911 895-7575

E-Mail: sitrain.digital.industry.academy.de@siemens.com

SITRAIN – Digital Industry Academy

www.siemens.com/sitrain

- SITRAIN open:
www.siemens.com/sitrain-open
- SITRAIN access:
www.siemens.com/sitrain-access
- SITRAIN personal:
www.siemens.com/sitrain-personal

Overview



SINAMICS S210 training case

The SINAMICS S210 training case is a convincing demonstration system thanks to its compact design. It is suitable for direct presentations as well as for tests in technical departments. The training case enables the functions of SINAMICS S210 servo drive system to be demonstrated and tested quickly and easily.

It contains the following components:

- 2 × SINAMICS S210 servo converters, 0.1 kW, 230 V 1 AC
- 2 × SIMOTICS S-1FK2 servomotors, High Dynamic
- 2 × One Cable Connection (OCC) motor connection cable
- Rail, prepared for installation of a controller, e.g. SIMATIC S7-1500 (controller not included in scope of supply)

The SINAMICS S210 training case is supplied as a trolley with a hood.

Technical specifications

SINAMICS S210 training case	6AG1067-1AA33-0AA0
Supply voltage	230 V 1 AC
Dimensions	
• Width	420 mm (16.54 in)
• Height	580 mm (22.83 in)
• Depth	340 mm (13.39 in)
Weight, approx.	21 kg (46.3 lb)

Selection and ordering data

Description	Article No.
SINAMICS S210 training case	6AG1067-1AA33-0AA0

Services and documentation

Applications

Overview



Our understanding of an application is the customer-specific solution of an automation task based on standard hardware and software components. In this respect, industry knowledge and technological expertise are just as important as expert knowledge about how our products and systems work. We are setting ourselves this challenge with more than 280 application engineers in 20 countries.

Application centers

We currently have application centers in:

- Germany: Head Office in Erlangen and in other German regions, e.g. in Munich, Nuremberg, Stuttgart, Mannheim, Frankfurt, Chemnitz, Cologne, Bielefeld, Bremen, Hanover, Hamburg
- Belgium: Brussels
- Brazil: Sao Paulo
- China: Beijing and 12 regions
- Denmark: Ballerup
- France: Paris
- Great Britain: Manchester
- India: Mumbai
- Italy: Bologna, Milan
- Japan: Tokyo, Osaka
- The Netherlands: The Hague
- Austria: Vienna
- Poland: Warsaw
- Sweden: Göteborg
- Switzerland: Zurich, Lausanne
- Spain: Madrid
- South Korea: Seoul
- Taiwan: Taipei
- Turkey: Istanbul
- USA: Atlanta

These application centers specialize in the use of SIMATIC/SIMOTION/SINAMICS. You therefore can rely on automation and drive specialists for implementing successful applications. By involving your personnel at an early stage in the process, we can provide a solid basis for rapid knowledge transfer, maintenance and further development of your automation solution.

Advice on applications and implementation

We offer a variety of consultation services to help you find the optimum solution for the SIMATIC/SIMOTION/SINAMICS application you want to implement:

The quotation phase includes

- clarification of technical questions,
- discussion of machine concepts and customer-specific solutions,
- selection of suitable technology and
- suggestions for implementation.

A technical feasibility study is also performed at the outset. In this way, difficult points of the application can be identified and solved early on. We can also configure and implement your application as a complete solution from a single source.

A large number of proven standard applications are available for use during the implementation phase. This saves engineering costs.

The system can be commissioned by experienced, competent personnel, if required. This saves time and trouble.

If servicing is required, we can support you on site or remotely. For further information about servicing, please see the section "Industry Services".

On-site application training

Training for the implemented applications can also be organized and carried out on site. This training for machine manufacturers and their customers does not deal with individual products, but the entire hardware and software system (for example, automation, drives and visualization).

From an initial concept to successful installation and commissioning: We provide complete support for SIMATIC/SIMOTION/SINAMICS! Contact your Siemens representative.

You can find further information at www.siemens.com/machinebuilding

Overview

Siemens Product Partners for Drives Options

Individual options for our drives

In order to meet as many customer requirements as possible in the field of drive technology, in addition to its own products, Siemens also relies on the individual and complementary services of selected partners.

We are increasingly focusing on the standard drive options, and our Siemens Product Partners for Drives Options supplement our drives with individual drive options.

This gives Siemens a unique flexibility to meet all application requirements. Naturally, we support our Siemens Product Partners for Drives Options in tailoring their options perfectly to our drives.

For you as our customer, there are multiple benefits:

- The Siemens Product Partners for Drives Options meet the same high standards of quality and performance that we place on our own products
- Drive options can be adapted to individual requirements/designs
- The Siemens Product Partners for Drives Options know our Siemens converter portfolio and can advise you individually and quickly

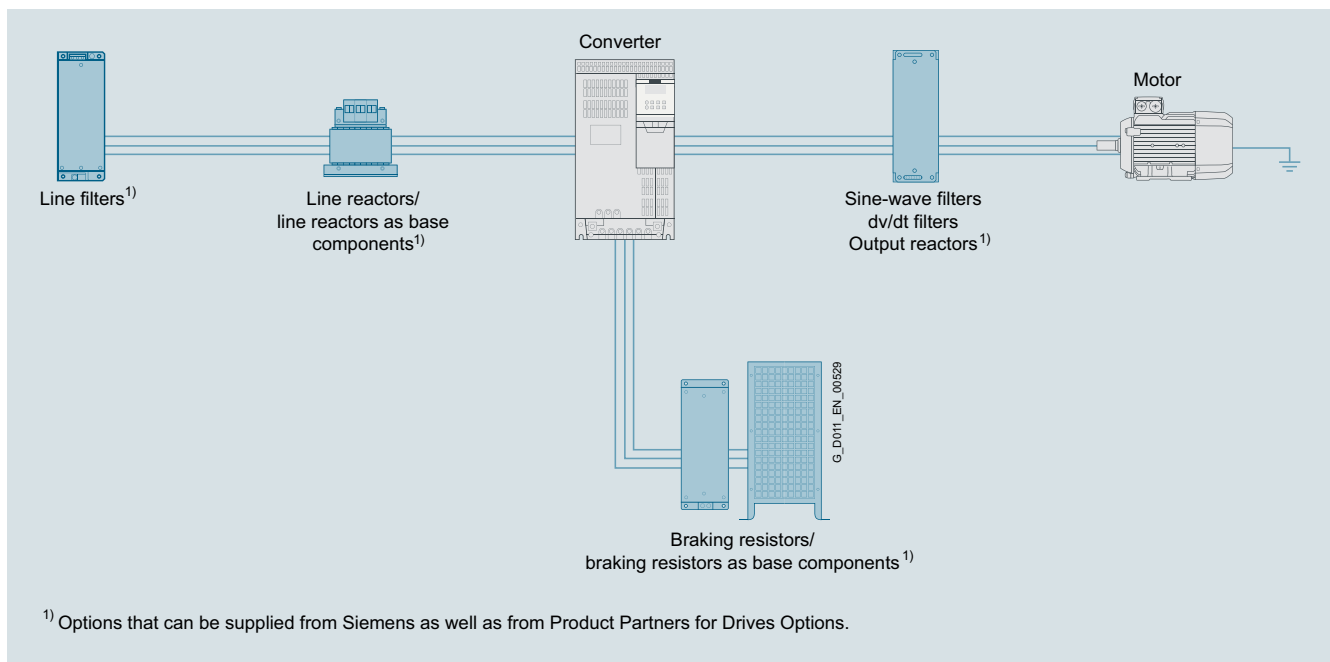

More information

You can find more information on the Internet at www.siemens.com/drives-options-partner

Services and documentation

mySupport documentation

Overview

mySupport documentation – Compiling personal documents

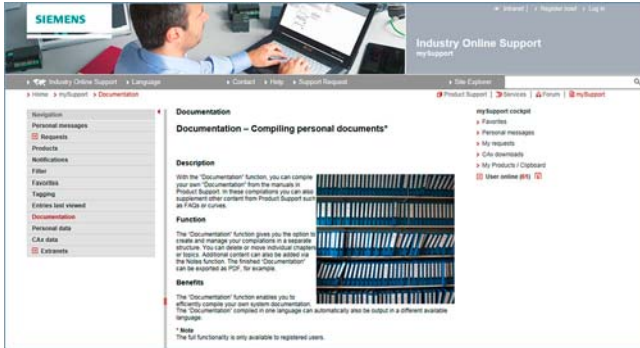

mySupport documentation is a web-based system for generating personalized documentation based on standard documents and is part of the Siemens Industry Online Support portal.

In mySupport, a personal document library can be created in the "Documentation" category. This library can be accessed online in mySupport or also be generated in various formats for offline use.

Previously, this functionality was available in the My Documentation Manager for configurable manuals. Due to the integration in mySupport, all entries of the Industry Online Support can now be imported into the personal document library, including FAQs or product notifications.

If you have already worked with the My Documentation Manager, all of the previously created libraries will continue to be available without restrictions in mySupport.

In addition, the personal library in mySupport can be shared with other mySupport users. In this way, a collection of relevant documents can be created very effectively and used together with other mySupport users all over the world.

You must register/log in for configuring and generating/managing.

Benefits

- Display
View, print or download standard documents or personalized documents
- Configure
Transfer standard documents or parts of them to personalized documents
- Generate/Manage
Generate and manage personalized documents in the formats PDF, RTF or XML in all available languages

Function

Opening mySupport documentation in the Industry Online Support portal

- Via the product support, entry type "Manual":
<https://support.industry.siemens.com/cs/ww/en/ps/manual>
By clicking on the required version of the manual and then "Show and configure", the manual opens in a modular view, where you can navigate from topic to topic. Here the direct link to a topic can be used and made available to other users. The selected document can be added to the personal library via "mySupport Cockpit" > "Add to mySupport documentation".
- Via the direct link
<https://support.industry.siemens.com/my/ww/en/documentation/advanced>
After logon/registration, the online help is displayed as the current document.

More information

You can find additional information on the Internet at

- <https://support.industry.siemens.com/my/ww/en/documentation>
- https://support.industry.siemens.com/cs/helpcenter/en/index.htm?#persoenliche_bibliothek_aufbauen.htm

Overview

A high-quality programmable control or drive system can be used to maximum effect only if the user is aware of the performance of the products used as a result of intensive training and good technical documentation.

This is becoming more important due to the shorter innovation cycles of modern automation products and the convergence of electronics and mechanical engineering.

A comprehensive range of documentation is available which includes a Getting Started guide, operating instructions, installation manuals and a list manual.

The documents are available in hardcopy form or as a PDF file for downloading from the Internet.

Information and documentation relating to SINUMERIK, SINAMICS, SIMOTION and SIMOTICS are available on the Internet at

<https://support.industry.siemens.com/cs/document/109476679>

In addition to many other useful documents, the Information and Download Center also contains catalogs about the following systems:

- SINUMERIK: NC 62, NC 81.1, NC 82
- SINAMICS: D 11, D 12, D 21.3, D 21.4, D 23.1, D 23.2, D 31.1, D 31.2, D 31.5, D 32, D 33, D 35
- SIMOTION: PM 21
- SIMOTICS: D 21.4, D 41, D 81.1, D 81.8, D 83.1

You can download these catalogs in PDF format – you don't need to log on. You can perform a targeted search using the filter box above the first displayed catalog. By entering the search term "NC 8", for example, you can locate Catalog NC 81.1 and Catalog NC 82, and by entering "ST 70" you will find Catalog ST 70 as well as the relevant news and add-ons (if available).

www.siemens.com/industry/infocenter

Application

Explanations of the manuals:

- **Operating Instructions**
contain all the information needed to install the device and make electrical connections, information about commissioning and a description of the converter functions.
Phases of use: Control cabinet construction, commissioning, operation, maintenance and servicing.
- **Hardware Installation Manual**
contains all relevant information about the intended use of the components of a system (technical specifications, interfaces, dimensional drawings, characteristics, or possible applications), information about installation and electrical connections and information about maintenance and servicing.
Phases of use: Control cabinet configuration/construction, maintenance and servicing.
- **Operating and Installation Instructions**
(for converter and accessories)
contain all relevant information about the intended use of the components, such as technical specifications, interfaces, dimensional drawings, characteristics, or possible applications.
Phases of use: Control cabinet configuration/construction.
- **Manual/Configuration Manual**
contains all necessary information about the intended use of the components of a system, e.g. technical specifications, interfaces, dimensional drawings, characteristics, or possible applications.
Phases of use: Cabinet configuration/setup, circuit diagram configuration/drawing.
- **Commissioning Manual**
contains all information relevant to commissioning after installation and wiring. It also contains all safety and warning notices relevant to commissioning in addition to overview drawings.
Phases of use: Commissioning of components that have already been connected, configuration of system functions.
- **List Manual**
contains all parameters, function diagrams, and faults/alarms for the product/system as well as their meanings and setting options. It contains parameter data and fault/alarm descriptions with functional correlations.
Phases of use: Commissioning of components that have already been connected, configuration of system functions, fault cause/diagnosis.
- **Getting Started**
provides information about getting started for the first-time user as well as references to additional information. It contains information about the basic steps to be taken during commissioning. The information in the other documentation should be carefully observed for all of the other work required.
Phases of use: Commissioning of components that have already been connected.
- **Function Manual Drive Functions**
contains all the relevant information about individual drive functions: Description, commissioning and integration in the drive system.
Phases of use: Commissioning of components that have already been connected, configuration of system functions.

Services and documentation

Documentation

General documentation

Overview

Description	Article No.
Decentralization with PROFIBUS DP/DPV1 <ul style="list-style-type: none"> • German • English 	Via bookstore ISBN 978-3-89578-189-6 ISBN 978-3-89578-218-3
Automating with PROFINET: Industrial Communication Based on Industrial Ethernet <ul style="list-style-type: none"> • German • English 	Via bookstore ISBN 978-3-89578-293-0 ISBN 978-3-89578-294-7
Configuration Manual EMC Installation Guideline SIMOCRANE, SIMOTICS, SIMOTION, SINAMICS, SINUMERIK <ul style="list-style-type: none"> • German • English • Italian • French • Spanish • Chinese Simplified 	 6FC5297-0AD30-0AP3 6FC5297-0AD30-0BP3 6FC5297-0AD30-0CP3 6FC5297-0AD30-0DP3 6FC5297-0AD30-0EP3 6FC5297-0AD30-0RP3

SINAMICS S210 documentation

Overview

A **Quick Installation Guide** is supplied in hard copy form in English with every SINAMICS S210. Further documentation, such as the operating instructions, is available free on the Internet at:

www.siemens.com/sinamics-s210/documentation

Detailed information on the SINAMICS S210 drive system, including the latest technical documentation (brochures, tutorials, dimensional drawings, certificates, manuals and operating instructions), is available on the Internet at:

www.siemens.com/sinamics-s210

and is also available via the Drive Technology Configurator (DT Configurator) on the Internet.

The DT Configurator can be found in the Siemens Industry Mall at the following address:

www.siemens.com/dt-configurator

Appendix



7/2	Certificates of suitability (approvals)
7/4	Software licenses
7/6	Conversion tables
7/8	Metal surcharges
7/11	Conditions of sale and delivery

Appendix

Certificates of suitability (approvals)







Overview

Many of the products in this catalog fulfill requirements, e.g. for UL, CSA or FM and are labeled with the corresponding approval designation.

All of the certificates of suitability, approvals, certificates, declarations of conformity, test certificates, e.g. CE, UL, Safety Integrated etc. have been performed with the associated system components as they are described in the Catalogs and Configuration Manuals.

The certificates are only valid if the products are used with the described system components, are installed according to the Installation Guidelines and used for their intended purpose.

In other cases, the vendor of these products is responsible for arranging for the issue of new certificates.

Test code	Tested by	Device series/ Component	Test standard	Product category/ File-No.
UL: Underwriters Laboratories Independent public testing body in North America				
	UL according to UL standard	SINUMERIK	Standard UL 508, CSA C22.2 No. 142	NRAQ/7.E164110 NRAQ/7.E217227
		SIMOTION	Standard UL 508, CSA C22.2 No. 142	NRAQ/7.E164110
	UL according to CSA standard	SINAMICS	Standard UL 508, 508C, 61800-5-1 CSA C22.2 No. 142, 274	NRAQ/7.E164110, NMMS/2/7/8.E192450, NMMS/7.E214113, NMMS/7.E253831
	UL according to UL and CSA standards			NMMS/2/7/8.E121068 NMMS/7.E355661 NMMS/7.E323473
	UL according to UL standard	SIMODRIVE	Standard UL 508C, CSA C22.2 No. 274	NMMS/2/7/8.E192450 NMMS/7.E214113
	UL according to CSA standard	SIMOTICS	Standard UL 1004-1, 1004-6, 1004-8, CSA C22.2 No. 100	PRGY2/8.E227215 PRHZ2/8.E93429 PRHJ2/8.E342747 PRGY2/8.E253922 PRHZ2/8.E342746
	UL according to UL and CSA standards			
		Line/motor reactors	Standard UL 508, 506, 5085-1, 5085-2, 1561, CSA C22.2 No. 14, 47, 66.1-06, 66.2-06	XQNX2/8.E257859 NMTR2/8.E219022 NMMS2/8.E333628 XPTQ2/8.E257852 XPTQ2/8.E103521 NMMS2/8.E224872 XPTQ2/8.E354316 XPTQ2/8.E198309 XQNX2/8.E475972
		Line filters, dv/dt filters, sine-wave filters	UL 1283, CSA C22.2 No. 8	FOKY2/8.E70122
		Resistors	UL 508, 508C, CSA C22.2 No. 14, 274	NMTR2/8.E224314 NMMS2/8.E192450 NMTR2/8.E221095 NMTR2/8.E226619
TUV: TÜV Rheinland of North America Inc. Independent public testing body in North America, Nationally Recognized Testing Laboratory (NRTL)				
TÜV: TÜV SÜD Product Service Independent public testing body in Germany, Nationally Recognized Testing Laboratory (NRTL) for North America				
	TUV according to UL and CSA standards	SINAMICS	NRTL listing according to standard UL 508C	U7V 12 06 20078 013 U7 11 04 20078 009 U7 11 04 20078 010 U7 11 04 20078 011
		SIMOTION	NRTL listing according to standard UL 508	U7V 13 03 20078 01
		SIMODRIVE	NRTL listing according to standard UL 508C, CSA C22.2. No. 14	CU 72090702
		Motion Control Encoder	NRTL listing according to UL 61010-1 CSA C22.2 No. 61010-1	U8V 10 06 20196 024

Certificates of suitability (approvals)

Overview (continued)

Test code	Tested by	Device series/ Component	Test standard	Product category/ File-No.
CSA: Canadian Standards Association Independent public testing body in Canada				
	CSA according to CSA standard	SINUMERIK	Standard CSA C22.2 No. 142	2252-01 : LR 102527
FMRC: Factory Mutual Research Corporation Independent public testing body in North America				
	FM according to FM standard	SINUMERIK	Standard FMRC 3600, FMRC 3611, FMRC 3810, ANSI/ISA S82.02.1	-
EAC: Ivanovo-Certificate Independent public testing body in the Russian Federation				
	EAC in accordance with the EAC Directive	SINAMICS SINUMERIK SIMOTION	Standard IEC 61800-5-1/-2, IEC 61800-3	-
RCM: Australian Communications and Media Authority Independent public testing body in Australia				
	RCM according to EMC standard	SINAMICS SINUMERIK SIMOTION	Standard IEC AS 61800-3, EN 61800-3	-
KC: National Radio Research Agency Independent public testing body in South Korea				
	KC according to EMC standard	SINAMICS SINUMERIK SIMOTION	Standard KN 11	-
BIA Federal Institute for Occupational Safety				
-	Functional safety	SINAMICS SINUMERIK SIMOTION	Standard EN 61800-5-2	-
TÜV SÜD Rail				
-	Functional safety	SINAMICS SINUMERIK SIMOTION	Standard EN 61800-5-2	-

More information about certificates can be found online at:
<https://support.industry.siemens.com/cs/ww/en/ps/cert>

Appendix

Software licenses

Overview

Software types

Software requiring a license is categorized into types. The following software types have been defined:

- Engineering software
- Runtime software

Engineering software

This includes all software products for creating (engineering) user software, e.g. for configuring, programming, parameterizing, testing, commissioning or servicing. Data generated with engineering software and executable programs can be duplicated for your own use or for use by third-parties free-of-charge.

Runtime software

This includes all software products required for plant/machine operation, e.g. operating system, basic system, system expansions, drivers, etc.

The duplication of the runtime software and executable programs created with the runtime software for your own use or for use by third-parties is subject to a charge.

You can find information about license fees according to use in the ordering data (e.g. in the catalog). Examples of categories of use include per CPU, per installation, per channel, per instance, per axis, per control loop, per variable, etc.

Information about extended rights of use for parameterization/configuration tools supplied as integral components of the scope of supply can be found in the readme file supplied with the relevant product(s).

License types

Siemens Industry Automation & Drive Technologies offers various types of software license:

- Floating license
- Single license
- Rental license
- Rental floating license
- Trial license
- Demo license
- Demo floating license

Floating license

The software may be installed for internal use on any number of devices by the licensee. Only the concurrent user is licensed.

The concurrent user is the person using the program. Use begins when the software is started.

A license is required for each concurrent user.

Single license

Unlike the floating license, a single license permits only one installation of the software per license.

The type of use licensed is specified in the ordering data and in the Certificate of License (CoL). Types of use include for example per instance, per axis, per channel, etc.

One single license is required for each type of use defined.

Rental license

A rental license supports the "sporadic use" of engineering software. Once the license key has been installed, the software can be used for a specific period of time (the operating hours do not have to be consecutive).

One license is required for each installation of the software.

Rental floating license

The rental floating license corresponds to the rental license, except that a license is not required for each installation of the software. Rather, one license is required per object (for example, user or device).

Trial license

A trial license supports "short-term use" of the software in a non-productive context, e.g. for testing and evaluation purposes. It can be transferred to another license.

Demo license

The demo license support the "sporadic use" of engineering software in a non-productive context, for example, use for testing and evaluation purposes. It can be transferred to another license. After the installation of the license key, the software can be operated for a specific period of time, whereby usage can be interrupted as often as required.

One license is required per installation of the software.

Demo floating license

The demo floating license corresponds to the demo license, except that a license is not required for each installation of the software. Rather, one license is required per object (for example, user or device).

Certificate of License (CoL)

The CoL is the licensee's proof that the use of the software has been licensed by Siemens. A CoL is required for every type of use and must be kept in a safe place.

Downgrading

The licensee is permitted to use the software or an earlier version/release of the software, provided that the licensee owns such a version/release and its use is technically feasible.

Delivery versions

Software is constantly being updated.

The following delivery versions

- PowerPack
- Upgrade

can be used to access updates.

Existing bug fixes are supplied with the ServicePack version.

PowerPack

PowerPacks can be used to upgrade to more powerful software.

The licensee receives a new license agreement and CoL (Certificate of License) with the PowerPack. This CoL, together with the CoL for the original product, proves that the new software is licensed.

A separate PowerPack must be purchased for each original license of the software to be replaced.

Overview (continued)**Upgrade**

An upgrade permits the use of a new version of the software on the condition that a license for a previous version of the product is already held.

The licensee receives a new license agreement and CoL with the upgrade. This CoL, together with the CoL for the previous product, proves that the new version is licensed. A separate upgrade must be purchased for each original license of the software to be upgraded.

ServicePack

ServicePacks are used to debug existing products. ServicePacks may be duplicated for use as prescribed according to the number of existing original licenses.

License key

Siemens Industry Automation & Drive Technologies supplies software products with and without license keys. The license key serves as an electronic license stamp and is also the "switch" for activating the software (floating license, rental license, etc.). The complete installation of software products requiring license keys includes the program to be licensed (the software) and the license key (which represents the license).

Software Update Service (SUS)

As part of the SUS contract, all software updates for the respective product are made available to you free of charge for a period of one year from the invoice date. The contract will automatically be extended for one year if it is not canceled three months before it expires.

The possession of the current version of the respective software is a basic condition for entering into an SUS contract.

You can download explanations concerning license conditions from www.siemens.com/automation/salesmaterial-as/catalog/en/terms_of_trade_en.pdf

Appendix

Conversion tables

Rotary inertia (to convert from A to B, multiply by entry in table)

A \ B	lb-in ²	lb-ft ²	lb-in-s ²	lb-ft-s ² slug-ft ²	kg-cm ²	kg-cm-s ²	gm-cm ²	gm-cm-s ²	oz-in ²	oz-in-s ²
lb-in ²	1	6.94×10^{-3}	2.59×10^{-3}	2.15×10^{-4}	2.926	2.98×10^{-3}	2.92×10^3	2.984	16	4.14×10^{-2}
lb-ft ²	144	1	0.3729	3.10×10^{-2}	421.40	0.4297	4.21×10^5	429.71	2304	5.967
lb-in-s ²	386.08	2.681	1	8.33×10^{-2}	1.129×10^3	1.152	1.129×10^6	1.152×10^3	6.177×10^3	16
lb-ft-s ² slug-ft ²	4.63×10^3	32.17	12	1	1.35×10^4	13.825	1.355×10^7	1.38×10^4	7.41×10^4	192
kg-cm ²	0.3417	2.37×10^{-3}	8.85×10^{-4}	7.37×10^{-5}	1	1.019×10^{-3}	1000	1.019	5.46	1.41×10^{-2}
kg-cm-s ²	335.1	2.327	0.8679	7.23×10^{-2}	980.66	1	9.8×10^5	1000	5.36×10^3	13.887
gm-cm ²	3.417×10^{-4}	2.37×10^{-6}	8.85×10^{-7}	7.37×10^{-8}	1×10^{-3}	1.01×10^{-6}	1	1.01×10^{-3}	5.46×10^{-3}	1.41×10^{-5}
gm-cm-s ²	0.335	2.32×10^{-3}	8.67×10^{-4}	7.23×10^{-5}	0.9806	1×10^{-3}	980.6	1	5.36	1.38×10^{-2}
oz-in ²	0.0625	4.34×10^{-4}	1.61×10^{-4}	1.34×10^{-5}	0.182	1.86×10^{-4}	182.9	0.186	1	2.59×10^{-3}
oz-in-s ²	24.13	0.1675	6.25×10^{-2}	5.20×10^{-3}	70.615	7.20×10^{-2}	7.09×10^4	72.0	386.08	1

Torque (to convert from A to B, multiply by entry in table)

A \ B	lb-in	lb-ft	oz-in	N-m	kg-cm	kg-m	gm-cm	dyne-cm
lb-in	1	8.333×10^{-2}	16	0.113	1.152	1.152×10^{-2}	1.152×10^3	1.129×10^6
lb-ft	12	1	192	1.355	13.825	0.138	1.382×10^4	1.355×10^7
oz-in	6.25×10^{-2}	5.208×10^{-3}	1	7.061×10^{-3}	7.200×10^{-2}	7.200×10^{-4}	72.007	7.061×10^4
N-m	8.850	0.737	141.612	1	10.197	0.102	1.019×10^4	1×10^7
kg-cm	0.8679	7.233×10^{-2}	13.877	9.806×10^{-2}	1	10^{-2}	1000	9.806×10^5
kg-m	86.796	7.233	1.388×10^3	9.806	100	1	1×10^5	9.806×10^7
gm-cm	8.679×10^{-4}	7.233×10^{-5}	1.388×10^{-2}	9.806×10^{-5}	1×10^{-3}	1×10^{-5}	1	980.665
dyne-cm	8.850×10^{-7}	7.375×10^{-8}	1.416×10^{-5}	10^{-7}	1.0197×10^{-6}	1.019×10^{-8}	1.019×10^{-3}	1

Length (to convert from A to B, multiply by entry in table)

A \ B	inches	feet	cm	yd	mm	m
inches	1	0.0833	2.54	0.028	25.4	0.0254
feet	12	1	30.48	0.333	304.8	0.3048
cm	0.3937	0.03281	1	1.09×10^{-2}	10	0.01
yd	36	3	91.44	1	914.4	0.914
mm	0.03937	0.00328	0.1	1.09×10^{-3}	1	0.001
m	39.37	3.281	100	1.09	1000	1

Force (to convert from A to B, multiply by entry in table)

A \ B	lb	oz	gm	dyne	N
lb	1	16	453.6	4.448×10^5	4.4482
oz	0.0625	1	28.35	2.780×10^4	0.27801
gm	2.205×10^{-3}	0.03527	1	1.02×10^{-3}	N.A.
dyne	2.248×10^{-6}	3.59×10^{-5}	980.7	1	0.00001
N	0.22481	3.5967	N.A.	100000	1

Mass (to convert from A to B, multiply by entry in table)

A \ B	lb	oz	gm	kg	slug
lb	1	16	453.6	0.4536	0.0311
oz	6.25×10^{-2}	1	28.35	0.02835	1.93×10^{-3}
gm	2.205×10^{-3}	3.527×10^{-2}	1	10^{-3}	6.852×10^{-5}
kg	2.205	35.27	10^3	1	6.852×10^{-2}
slug	32.17	514.8	1.459×10^4	14.59	1

Rotation (to convert from A to B, multiply by entry in table)

A \ B	rpm	rad/s	degrees/s
rpm	1	0.105	6.0
rad/s	9.55	1	57.30
degrees/s	0.167	1.745×10^{-2}	1

Power (to convert from A to B, multiply by entry in table)

A \ B	hp	Watts
hp (English)	1	745.7
(lb-in) (deg./s)	2.645×10^{-6}	1.972×10^{-3}
(lb-in) (rpm)	1.587×10^{-5}	1.183×10^{-2}
(lb-ft) (deg./s)	3.173×10^{-5}	2.366×10^{-2}
(lb-ft) (rpm)	1.904×10^{-4}	0.1420
Watts	1.341×10^{-3}	1

Temperature Conversion

°F	°C	°C	°F
0	-17.8	-10	14
32	0	0	32
50	10	10	50
70	21.1	20	68
90	32.2	30	86
98.4	37	37	98.4
212	100	100	212
subtract 32 and multiply by $\frac{5}{9}$		multiply by $\frac{9}{5}$ and add 32	

Mechanism Efficiencies

Acme-screw with brass nut	~0.35–0.65
Acme-screw with plastic nut	~0.50–0.85
Ball-screw	~0.85–0.95
Chain and sprocket	~0.95–0.98
Preloaded ball-screw	~0.75–0.85
Spur or bevel-gears	~0.90
Timing belts	~0.96–0.98
Worm gears	~0.45–0.85
Helical gear (1 reduction)	~0.92

Friction Coefficients

Materials	μ
Steel on steel (greased)	~0.15
Plastic on steel	~0.15–0.25
Copper on steel	~0.30
Brass on steel	~0.35
Aluminum on steel	~0.45
Steel on steel	~0.58
Mechanism	μ
Ball bushings	<0.001
Linear bearings	<0.001
Dove-tail slides	~0.2++
Gibb ways	~0.5++

Material Densities

Material	lb-in ³	gm-cm ³
Aluminum	0.096	2.66
Brass	0.299	8.30
Bronze	0.295	8.17
Copper	0.322	8.91
Hard wood	0.029	0.80
Soft wood	0.018	0.48
Plastic	0.040	1.11
Glass	0.079–0.090	2.2–2.5
Titanium	0.163	4.51
Paper	0.025–0.043	0.7–1.2
Polyvinyl chloride	0.047–0.050	1.3–1.4
Rubber	0.033–0.036	0.92–0.99
Silicone rubber, without filler	0.043	1.2
Cast iron, gray	0.274	7.6
Steel	0.280	7.75

Wire Gauges¹⁾

Cross-section mm ²	Standard Wire Gauge (SWG)	American Wire Gauge (AWG)
0.2	25	24
0.3	23	22
0.5	21	20
0.75	20	19
1.0	19	18
1.5	17	16
2.5	15	13
4	13	11
6	12	9
10	9	7
16	7	6
25	5	3
35	3	2
50	0	1/0
70	000	2/0
95	00000	3/0
120	0000000	4/0
150	–	6/0
185	–	7/0

¹⁾ The table shows approximate SWG/AWG sizes nearest to standard metric sizes; the cross-sections do not match exactly.

Appendix

Metal surcharges

Explanation of the raw material/metal surcharges ¹⁾

Surcharge calculation

To compensate for variations in the price of the raw materials silver, copper, aluminum, lead, gold, dysprosium ²⁾ and/or neodym ²⁾, surcharges are calculated on a daily basis using the so-called metal factor for products containing these raw materials. A surcharge for the respective raw material is calculated as a supplement to the price of a product if the basic official price of the raw material in question is exceeded.

The surcharges are calculated in accordance with the following criteria:

- Basic official price of the raw material
Basic official price from the day prior to receipt of the order or prior to release order (daily price) for ³⁾
- Silver (sales price, processed)
- Gold (sales price, processed)
and for ⁴⁾
- Copper (lower DEL notation + 1 %)
- Aluminum (aluminum in cables)
- Lead (lead in cables)
- Metal factor of the products
Certain products are displayed with a metal factor. The metal factor determines the official price (for those raw materials concerned) as of which the metal surcharges are applied and the calculation method used (weight or percentage method). An exact explanation is given below.

Structure of the metal factor

The metal factor consists of several digits; the first digit indicates whether the percentage method of calculation refers to the list price or a possible discounted price (customer net price) (L = list price / N = customer net price).

The remaining digits indicate the method of calculation used for the respective raw material. If no surcharge is added for a raw material, a "-" is used.

1st digit	List or customer net price using the percentage method
2nd digit	for silver (AG)
3rd digit	for copper (CU)
4th digit	for aluminum (AL)
5th digit	for lead (PB)
6th digit	for gold (AU)
7th digit	for dysprosium (Dy) ²⁾
8th digit	for neodym (Nd) ²⁾

Weight method

The weight method uses the basic official price, the daily price and the raw material weight. In order to calculate the surcharge, the basic official price must be subtracted from the daily price. The difference is then multiplied by the raw material weight.

The basic official price can be found in the table below using the number (1 to 9) of the respective digit of the metal factor. The raw material weight can be found in the respective product descriptions.

Percentage method

Use of the percentage method is indicated by the letters A-Z at the respective digit of the metal factor.

The surcharge is increased - dependent on the deviation of the daily price compared with the basic official price - using the percentage method in "steps" and consequently offers surcharges that remain constant within the framework of this "step range". A higher percentage rate is charged for each new step. The respective percentage level can be found in the table below.

Metal factor examples

L E A - - - - -	Basis for % surcharge: List price
	Silver Basis 150 €, Step 50 €, 0.5 %
	Copper Basis 150 €, Step 50 €, 0.1 %
	No surcharge for aluminum
	No surcharge for lead
	No surcharge for gold
	No surcharge for dysprosium
	No surcharge for neodym

N - A 6 - - - - -	Basis for % surcharge: Customer net price
	No surcharge for silver
	Copper Basis 150 €, Step 50 €, 0.1 %
	Aluminum acc. to weight, basic offic. price 225 €
	No surcharge for lead
	No surcharge for gold
	No surcharge for dysprosium
	No surcharge for neodym

- - 3 - - - - -	No basis necessary
	No surcharge for silver
	Copper acc. to weight, basic official price 150 €
	No surcharge for aluminum
	No surcharge for lead
	No surcharge for gold
	No surcharge for dysprosium
	No surcharge for neodym

¹⁾ Refer to the separate explanation on the next page regarding the raw materials dysprosium and neodym (= rare earths).

²⁾ For a different method of calculation, refer to the separate explanation for these raw materials on the next page.

³⁾ Source: Umicore, Hanau (www.metalsmanagement.umicore.com).

⁴⁾ Source: Schutzvereinigung DEL-Notiz e.V. (www.del-notiz.org).

Explanation of the raw material/metal surcharges for dysprosium and neodym (rare earths)

Surcharge calculation

To compensate for variations in the price of the raw materials silver ¹⁾, copper ¹⁾, aluminum ¹⁾, lead ¹⁾, gold ¹⁾, dysprosium and/or neodym, surcharges are calculated on a daily basis using the so-called metal factor for products containing these raw materials. The surcharge for dysprosium and neodym is calculated as a supplement to the price of a product if the basic official price of the raw material in question is exceeded.

The surcharge is calculated in accordance with the following criteria:

- Basic official price of the raw material ²⁾
Three-month basic average price (see below) in the period before the quarter in which the order was received or the release order took place (= average official price) for
- dysprosium (Dy metal, 99 % min. FOB China; USD/kg)
- neodym (Nd metal, 99 % min. FOB China; USD/kg)
- Metal factor of the products
Certain products are displayed with a metal factor. The metal factor indicates (for those raw materials concerned) the basic official price as of which the surcharges for dysprosium and neodym are calculated using the weight method. An exact explanation of the metal factor is given below.

Three-month average price

The prices of rare earths vary according to the foreign currency, and there is no freely accessible stock exchange listing. This makes it more difficult for all parties involved to monitor changes in price. In order to avoid continuous adjustment of the surcharges, but to still ensure fair, transparent pricing, an average price is calculated over a three-month period using the average monthly foreign exchange rate from USD to EUR (source: European Central Bank). Since not all facts are immediately available at the start of each month, a one-month buffer is allowed before the new average price applies.

Examples of calculation of the average official price:

Period for calculation of the average price:	Period during which the order/release order is effected and the average price applies:
Sep 2012 - Nov 2012	Q1 in 2013 (Jan - Mar)
Dec 2012 - Feb 2013	Q2 in 2013 (Apr - Jun)
Mar 2013 - May 2013	Q3 in 2013 (Jul - Sep)
Jun 2013 - Aug 2013	Q4 in 2013 (Oct - Dec)

Structure of the metal factor

The metal factor consists of several digits; the first digit is not relevant to the calculation of dysprosium and neodym.

The remaining digits indicate the method of calculation used for the respective raw material. If no surcharge is added for a raw material, a "-" is used.

1st digit	List or customer net price using the percentage method
2nd digit	for silver (AG) ¹⁾
3rd digit	for copper (CU) ¹⁾
4th digit	for aluminum (AL) ¹⁾
5th digit	for lead (PB) ¹⁾
6th digit	for gold (AU) ¹⁾
7th digit	for dysprosium (Dy)
8th digit	for neodym (Nd)

Weight method

The weight method uses the basic official price, the average price and the raw material weight. In order to calculate the surcharge, the basic official price must be subtracted from the average price. The difference is then multiplied by the raw material weight.

The basic official price can be found in the table below using the number (1 to 9) of the respective digit of the metal factor. Your Sales contact can inform you of the raw material weight.

Metal factor examples

Metal factor	Description
-----71	No basis necessary
	No surcharge for silver
	No surcharge for copper
	No surcharge for aluminum
	No surcharge for lead
	No surcharge for gold
	Dysprosium acc. to weight, basic official price 300 €
	Neodym acc. to weight, basic official price 50 €

¹⁾ For a different method of calculation, refer to the separate explanation for these raw materials on the previous page.

²⁾ Source: Asian Metal Ltd (www.asianmetal.com)

Appendix

Metal surcharges

Values of the metal factor

Percentage method	Basic official price in €	Step range in €	% surcharge 1st step	% surcharge 2nd step	% surcharge 3rd step	% surcharge 4th step	% surcharge per additional step	
			Price in € 150.01 - 200.00	Price in € 200.01 - 250.00	Price in € 250.01 - 300.00	Price in € 300.01 - 350.00		
A	150	50	0.1	0.2	0.3	0.4	0.1	
B	150	50	0.2	0.4	0.6	0.8	0.2	
C	150	50	0.3	0.6	0.9	1.2	0.3	
D	150	50	0.4	0.8	1.2	1.6	0.4	
E	150	50	0.5	1.0	1.5	2.0	0.5	
F	150	50	0.6	1.2	1.8	2.4	0.6	
G	150	50	1.0	2.0	3.0	4.0	1.0	
H	150	50	1.2	2.4	3.6	4.8	1.2	
I	150	50	1.6	3.2	4.8	6.4	1.6	
J	150	50	1.8	3.6	5.4	7.2	1.8	
			175.01 - 225.00	225.01 - 275.00	275.01 - 325.00	325.01 - 375.00		
O	175	50	0.1	0.2	0.3	0.4	0.1	
P	175	50	0.2	0.4	0.6	0.8	0.2	
R	175	50	0.5	1.0	1.5	2.0	0.5	
			225.01 - 275.00	275.01 - 325.00	325.01 - 375.00	375.01 - 425.00		
S	225	50	0.2	0.4	0.6	0.8	0.2	
U	225	50	1.0	2.0	3.0	4.0	1.0	
V	225	50	1.0	1.5	2.0	3.0	1.0	
W	225	50	1.2	2.5	3.5	4.5	1.0	
			150.01 - 175.00	175.01 - 200.00	200.01 - 225.00	225.01 - 250.00		
Y	150	25	0.3	0.6	0.9	1.2	0.3	
			400.01 - 425.00	425.01 - 450.00	450.01 - 475.00	475.01 - 500.00		
Z	400	25	0.1	0.2	0.3	0.4	0.1	
Price basis (1st digit)								
L	Calculation based on the list price							
N	Calculation based on the customer net price (discounted list price)							
Weight method	Basic official price in €							
1	50	Calculation based on raw material weight						
2	100							
3	150							
4	175							
5	200							
6	225							
7	300							
8	400							
9	555							
Miscellaneous								
-	No metal surcharge							

1. General Provisions

By using this catalog you can purchase products (hardware, software and services) described therein from Siemens Aktiengesellschaft subject to the following Terms and Conditions of Sale and Delivery (hereinafter referred to as "T&C"). Please note that the scope, the quality and the conditions for supplies and services, including software products, by any Siemens entity having a registered office outside Germany, shall be subject exclusively to the General Terms and Conditions of the respective Siemens entity. The following T&C apply exclusively for orders placed with Siemens Aktiengesellschaft, Germany.

1.1 For customers with a seat or registered office in Germany

For customers with a seat or registered office in Germany, the following terms and conditions apply subordinate to T&C:

- for products, which include specific terms and conditions in the description text, these specific terms and conditions shall apply and subordinate thereto,
- for installation work the "General Conditions for Erection Works – Germany" ("Allgemeine Montagebedingungen – Deutschland" (currently only available in German)) and/or
- for stand-alone software products and software products forming a part of a product or project, the "General License Conditions for Software Products for Automation and Drives for Customers with a Seat or registered Office in Germany" ¹⁾ and/or
- for consulting services the "General Terms and Conditions for Consulting Services of the Division DF – Germany" ¹⁾ and/or
- for other supplies and/or services the "General Conditions for the Supply of Products and Services of the Electrical and Electronics Industry" ¹⁾.

In case such supplies and/or services should contain Open Source Software, the conditions of which shall prevail over the "General Conditions for the Supply of Products and Services of the Electrical and Electronics Industry" ¹⁾, a notice will be contained in the scope of delivery in which the applicable conditions for Open Source Software are specified. This shall apply mutatis mutandis for notices referring to other third party software components.

1.2 For customers with a seat or registered office outside Germany

For customers with a seat or registered office outside Germany, the following terms and conditions apply subordinate to T&C:

- for products, which include specific terms and conditions in the description text, these specific terms and conditions shall apply and subordinate thereto,
- for services the "International Terms & Conditions for Services" ¹⁾ supplemented by "Software Licensing Conditions" ¹⁾ and/or
- for consulting services the "General Terms and Conditions for Consulting Services of the Division DF – Germany" ¹⁾ and/or
- for other supplies of hard- and software the "International Terms Conditions for Products" ¹⁾ supplemented by "Software Licensing Conditions" ¹⁾

1.3 For customers with master or framework agreement

To the extent our supplies and/or services offered are covered by an existing master or framework agreement, the terms and conditions of that agreement shall apply instead of T&C.

2. Prices

The prices are in € (Euro) ex point of delivery, exclusive of packaging.

The sales tax (value added tax) is not included in the prices. It shall be charged separately at the respective rate according to the applicable statutory legal regulations.

Prices are subject to change without prior notice. We will charge the prices valid at the time of delivery.

To compensate for variations in the price of raw materials (e.g. silver, copper, aluminum, lead, gold, dysprosium and neodym), surcharges are calculated on a daily basis using the so-called metal factor for products containing these raw materials.

A surcharge for the respective raw material is calculated as a supplement to the price of a product if the basic official price of the raw material in question is exceeded.

The metal factor of a product indicates the basic official price (for those raw materials concerned) as of which the surcharges on the price of the product are applied, and with what method of calculation.

You will find a detailed explanation of the metal factor on the page headed "Metal surcharges".

To calculate the surcharge (except in the cases of dysprosium and neodym), the official price from the day prior to that on which the order was received or the release order was effected is used.

To calculate the surcharge applicable to dysprosium and neodym ("rare earths"), the corresponding three-month basic average price in the quarter prior to that in which the order was received or the release order was effected is used with a one-month buffer (details on the calculation can be found in the explanation of the metal factor).

3. Additional Terms and Conditions

The dimensions are in mm. In Germany, according to the German law on units in measuring technology, data in inches apply only to devices for export.

Illustrations are not binding.

Insofar as there are no remarks on the individual pages of this catalog – especially with regard to data, dimensions and weights given – these are subject to change without prior notice.

¹⁾ The text of the Terms and Conditions of Siemens AG can be downloaded at www.siemens.com/automation/salesmaterial-as/catalog/en/terms_of_trade_en.pdf

Appendix

Conditions of sale and delivery

4. Export Regulations

We shall not be obligated to fulfill any agreement if such fulfillment is prevented by any impediments arising out of national or international foreign trade or customs requirements or any embargoes and/or other sanctions.

Export may be subject to license. We shall indicate in the delivery details whether licenses are required under German, European and US export lists.

Our products are controlled by the U.S. Government (when labeled with "ECCN" unequal "N") and authorized for export only to the country of ultimate destination for use by the ultimate consignee or end-user(s) herein identified. They may not be resold, transferred, or otherwise disposed of, to any other country or to any person other than the authorized ultimate consignee or end-user(s), either in their original form or after being incorporated into other items, without first obtaining approval from the U.S. Government or as otherwise authorized by U.S. law and regulations.

The export indications can be viewed in advance in the description of the respective goods on the Industry Mall, our online catalog system. Only the export labels "AL" and "ECCN" indicated on order confirmations, delivery notes and invoices are authoritative.

Products labeled with "AL" unequal "N" are subject to European / national export authorization. Products without label, with label "AL:N" / "ECCN:N", or label "AL:9X9999" / "ECCN: 9X9999" may require authorization from responsible authorities depending on the final end-use, or the destination.

If you transfer goods (hardware and/or software and/or technology as well as corresponding documentation, regardless of the mode of provision) delivered by us or works and services (including all kinds of technical support) performed by us to a third party worldwide, you must comply with all applicable national and international (re-)export control regulations.

If required for the purpose of conducting export control checks, you (upon request by us) shall promptly provide us with all information pertaining to the particular end customer, final disposition and intended use of goods delivered by us respectively works and services provided by us, as well as to any export control restrictions existing in this relation.

The products listed in this catalog may be subject to European / German and/or US export regulations. Any export requiring approval is therefore subject to authorization by the relevant authorities.

Errors excepted and subject to change without prior notice.

Selection and ordering at Siemens Industry Mall, Catalog CA 01, downloading and ordering catalogs

Easy product selection and ordering: Industry Mall and Interactive Catalog CA 01

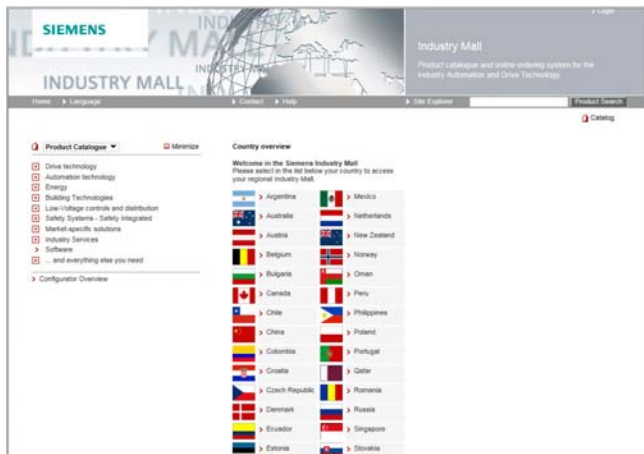

Industry Mall

The Industry Mall is a Siemens AG Internet ordering platform. It provides you with online access to a comprehensive product spectrum that is presented in an informative, well-organized way.

Powerful search functions help you select the required products, while configurators enable you to configure complex product and system components quickly and easily. CAx data are also available for you to use.

Data transfer allows the entire procedure, from selection through ordering to tracking and tracing, to be carried out online. Availability checks, individual customer discounting, and quotation preparation are also possible.

www.siemens.com/industrymall

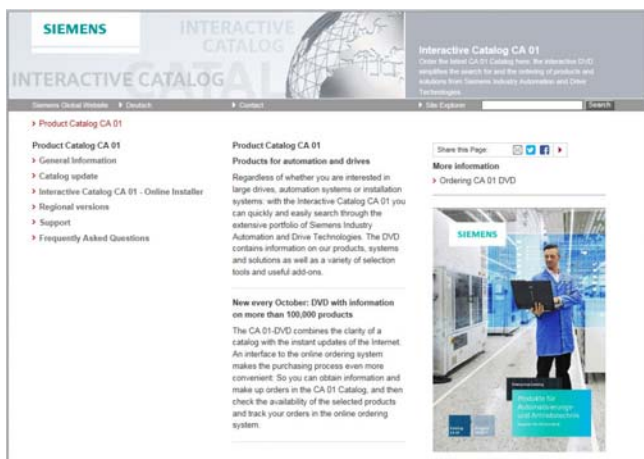

Interactive Catalog CA 01 – Products for automation and drives

The Interactive Catalog CA 01 combined with the Siemens Industry Mall unites the benefits of offline and online media in one application – the performance of an offline catalog with the availability of a wide range of up-to-date information on the Internet.

Select products and assemble orders using the CA 01, determine the availability of the selected products, and track and trace them via the Industry Mall.

Information and download:

www.siemens.com/automation/ca01

Downloading catalogs

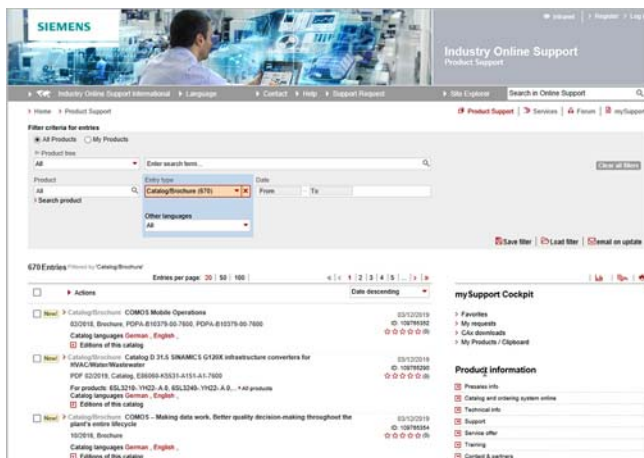

Siemens Industry Online Support

You can download catalogs and brochures in PDF format from Siemens Industry Online Support without having to register.

The filter box makes it possible to perform targeted searches.

www.siemens.com/industry-catalogs

Ordering printed catalogs



Please contact your local Siemens branch if you are interested in ordering printed catalogs.

Addresses can be found at

www.siemens.com/automation-contact

Get more information

SINAMICS S210 servo drive system:
usa.siemens.com/sinamics-s210

SIMOTICS electric motors:
usa.siemens.com/simotics

Motion Control Systems and Solutions
for production machine and machine tool equipment:
www.usa.siemens.com/motioncontrol

Local partners worldwide:
www.siemens.com/automation-contact

For the U.S. published by
Siemens Industry Inc.

5300 Triangle Parkway
Norcross, GA 30092
United States

Article No. DRCA-D32PDF-0419
V6.MKKATA.GMC.170
KG 0619 RIF 94 En
Produced in Germany
© Siemens 2019

Subject to changes and errors. The information given in this catalog only contains general descriptions and/or performance features which may not always specifically reflect those described, or which may undergo modification in the course of further development of the products. The requested performance features are binding only when they are expressly agreed upon in the concluded contract.

All product designations may be trademarks or product names of Siemens AG or other companies whose use by third parties for their own purposes could violate the rights of the owners.

Security information

Siemens provides products and solutions with industrial security functions that support the secure operation of plants, systems, machines and networks.

In order to protect plants, systems, machines and networks against cyber threats, it is necessary to implement – and continuously maintain – a holistic, state-of-the-art industrial security concept. Siemens' products and solutions constitute one element of such a concept.

Customers are responsible for preventing unauthorized access to their plants, systems, machines and networks. Such systems, machines and components should only be connected to an enterprise network or the internet if and to the extent such a connection is necessary and only when appropriate security measures (e.g. firewalls and/or network segmentation) are in place.

For additional information on industrial security measures that may be implemented, please visit
usa.siemens.com/industrialsecurity

Siemens' products and solutions undergo continuous development to make them more secure. Siemens strongly recommends that product updates are applied as soon as they are available and that the latest product versions are used. Use of product versions that are no longer supported, and failure to apply the latest updates may increase customer's exposure to cyber threats.

To stay informed about product updates, subscribe to the Siemens Industrial Security RSS Feed under
usa.siemens.com/industrialsecurity