



Pump control panel, NEMA Size 3, Three phase full voltage, 100A/250V fusible disconnect, Solid-state overload relay, OLR amp range 25-100A, 110/120 V AC 50/60Hz coil, HOA selector switch, Start push button, Enclosure NEMA type 3R, Weather proof outdoor use, Standards: UL 60947-1, Certifications: cULus, Listed Service Entrance Equip

design of the product	Pump control panel with fused disconnect switch
special product feature	ESP200 overload relay
<b>General technical data</b>	
weight [lb]	78 lb(av)
Height x Width x Depth [in]	41 × 24 × 8 in
touch protection against electrical shock	(NA for enclosed products)
installation altitude [ft] at height above sea level maximum	6560 ft
ambient temperature [°F]	
• during storage	-22 ... +149 °F
• during operation	-4 ... +104 °F
ambient temperature	
• during storage	-30 ... +65 °C
• during operation	-20 ... +40 °C
country of origin	Mexico
<b>Horsepower ratings</b>	
yielded mechanical performance [hp] for 3-phase AC motor	
• at 200/208 V rated value	20 hp
• at 220/230 V rated value	30 hp
• at 460/480 V rated value	0 hp
• at 575/600 V rated value	0 hp
<b>Contactors</b>	
size of contactor	NEMA controller size 3
number of NO contacts for main contacts	3
operating voltage for main current circuit at AC at 60 Hz maximum	240 V
operational current at AC at 600 V rated value	90 A
mechanical service life (operating cycles) of the main contacts typical	10000000
<b>Auxiliary contact</b>	
number of NC contacts at contactor for auxiliary contacts	1
number of NO contacts at contactor for auxiliary contacts	1
number of total auxiliary contacts maximum	4
contact rating of auxiliary contacts of contactor according to UL	10A@600VAC (A600), 5A@600VDC (P600)
<b>Coil</b>	
type of voltage of the control supply voltage	AC
control supply voltage	
• at DC rated value	0 ... 0 V
• at AC at 50 Hz rated value	110 ... 127 V
• at AC at 60 Hz rated value	110 ... 127 V
apparent pick-up power of magnet coil at AC	326 VA
apparent holding power of magnet coil at AC	22 VA

operating range factor control supply voltage rated value of magnet coil	0.8 ... 1.1
ON-delay time	13 ... 50 ms
OFF-delay time	10 ... 21 ms
<b>Overload relay</b>	
product function	
• overload protection	Yes
• phase failure detection	Yes
• asymmetry detection	Yes
• ground fault detection	Yes
• test function	Yes
• external reset	Yes
reset function	Manual, automatic and remote
trip class	Class 5 / 10 (factory set) / 20 / 30
adjustable current response value current of the current-dependent overload release	25 ... 100 A
tripping time at phase-loss maximum	3 s
relative repeat accuracy	1 %
product feature protective coating on printed-circuit board	Yes
number of NC contacts of auxiliary contacts of overload relay	1
number of NO contacts of auxiliary contacts of overload relay	1
operational current of auxiliary contacts of overload relay	
• at AC at 600 V	5 A
• at DC at 250 V	1 A
contact rating of auxiliary contacts of overload relay according to UL	5A@600VAC (B600), 1A@250VDC (R300)
insulation voltage (Ui)	
• with single-phase operation at AC rated value	600 V
• with multi-phase operation at AC rated value	300 V
<b>Disconnect Switch</b>	
response value of switch disconnecter	100A / 250V
design of fuse holder	Class H fuse clips
operating class of the fuse link	Class H, K and R
<b>Enclosure</b>	
degree of protection NEMA rating of the enclosure	NEMA Type 3R enclosure
design of the housing	Weather proof for outdoor use
<b>Standard Control Devices</b>	
product component Hand-Off-Auto selector switch	Yes
type of Hand-Off-Auto selector switch	30mm metal housing with matte finish
product component start push button	Yes
type of start push button	30mm metal housing with matte finish
<b>Mounting/wiring</b>	
mounting position	Vertical
fastening method	Surface mounting and installation
type of electrical connection for supply voltage line-side	Box lug
tightening torque [lbf-in] for supply	120 ... 120 lbf-in
type of connectable conductor cross-sections at line-side for AWG cables single or multi-stranded	1 x (14 ... 1/0 AWG)
temperature of the conductor for supply maximum permissible	75 °C
material of the conductor for supply	AL or CU
type of electrical connection for load-side outgoing feeder	Screw-type terminals
tightening torque [lbf-in] for load-side outgoing feeder	40 ... 53 lbf-in
type of connectable conductor cross-sections for AWG cables for load-side outgoing feeder single or multi-stranded	2x (10 ... 1/0), 1x (10 ... 2)
temperature of the conductor for load-side outgoing feeder maximum permissible	75 °C
material of the conductor for load-side outgoing feeder	CU
type of electrical connection of magnet coil	Screw-type terminals
tightening torque [lbf-in] at magnet coil	7 ... 10 lbf-in
type of connectable conductor cross-sections of magnet coil for AWG cables single or multi-stranded	2x (20 ... 16), 2x (18 ... 14)
temperature of the conductor at magnet coil maximum permissible	75 °C

material of the conductor at magnet coil	CU
type of electrical connection at contactor for auxiliary contacts	Screw-type terminals
tightening torque [lbf-in] at contactor for auxiliary contacts	7 ... 10 lbf-in
type of connectable conductor cross-sections at contactor for AWG cables for auxiliary contacts single or multi-stranded	2x (20 ... 16), 2x (18 ... 14)
temperature of the conductor at contactor for auxiliary contacts maximum permissible	75 °C
material of the conductor at contactor for auxiliary contacts	CU
type of electrical connection at overload relay for auxiliary contacts	Screw-type terminals
tightening torque [lbf-in] at overload relay for auxiliary contacts	7 ... 10 lbf-in
type of connectable conductor cross-sections at overload relay for AWG cables for auxiliary contacts single or multi-stranded	2 x (20 ... 14 AWG)
temperature of the conductor at overload relay for auxiliary contacts maximum permissible	75 °C
material of the conductor at overload relay for auxiliary contacts	CU

#### Short-circuit current rating

design of the fuse link for short-circuit protection of the main circuit required	10kA@600V (Class H or K); 100kA@600V (Class R or J)
certificate of suitability	NEMA ICS 2; UL 508

#### Approvals Certificates

General Product Approval	Test Certificates	other	Environment
--------------------------	-------------------	-------	-------------



[Confirmation](#)

[Environmental Confirmations](#)

#### Further information

**Industrial Controls - Product Overview (Catalogs, Brochures,...)**

[www.usa.siemens.com/iccatalog](http://www.usa.siemens.com/iccatalog)

**Industry Mall (Online ordering system)**

<https://mall.industry.siemens.com/mall/en/us/Catalog/product?mlfb=3RE4803-0GL36-4GA0>

**Service&Support (Manuals, Certificates, Characteristics, FAQs,...)**

<https://support.industry.siemens.com/cs/US/en/ps/3RE4803-0GL36-4GA0>

**Image database (product images, 2D dimension drawings, 3D models, device circuit diagrams, EPLAN macros, ...)**

[http://www.automation.siemens.com/bilddb/cax\\_de.aspx?mlfb=3RE4803-0GL36-4GA0&lang=en](http://www.automation.siemens.com/bilddb/cax_de.aspx?mlfb=3RE4803-0GL36-4GA0&lang=en)

**Certificates/approvals**

<https://support.industry.siemens.com/cs/US/en/ps/3RE4803-0GL36-4GA0/certificate>

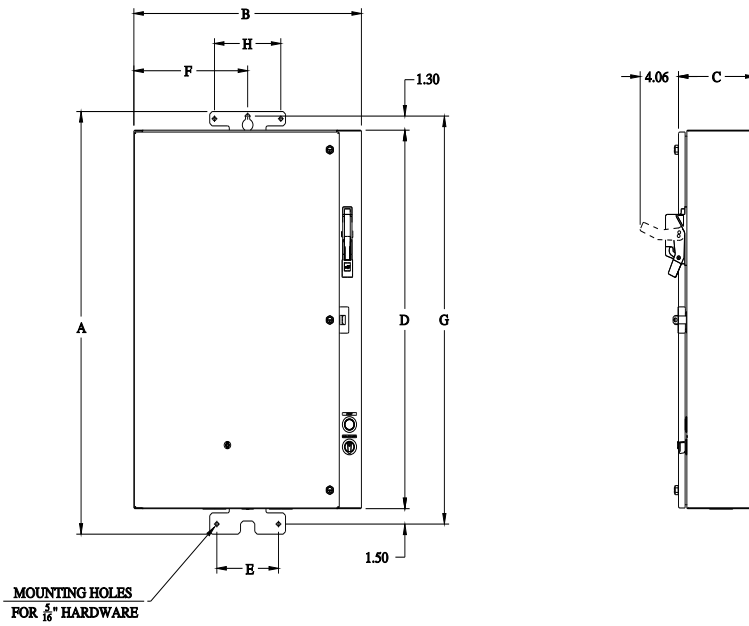

MOUNTING HOLES  
FOR  $\frac{1}{16}$ " HARDWARE

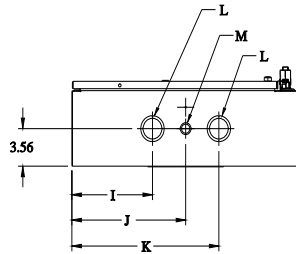

OUTLINE DIMENSIONS				
A	B	C		
40.20	24.00	8.06		
MOUNTING DIMENSIONS				
D	E	F	G	H
36.00	6.50	12.00	38.80	7.00
CONDUIT KNOCKOUT				
I	J	K	L	M
8.50	12.00	15.50	2.46-1.96	1.12-.875

A5E51602392A/B87010A0547-T005-A4

last modified:

1/18/2024