

Cable for COMPRO20 / COMMOD21  
Cable para COMPRO20 / COMMOD21  
Câble pour COMPRO20 / COMMOD21

<b>U.S. Cat. No.</b>	<b>Order No.</b>
COMKIT3	3VL9300-8AQ61
COMKIT4	3VL9400-8AQ61
COMKIT5	3VL9800-8AQ61
COMKIT6	3VL9300-8AQ71
COMKIT7	3VL9400-8AQ71
COMKIT8	3VL9800-8AQ71

For use with Frame DG, FG, JG, LG, MG, NG, PG  
Para usar con caja Base DG, FG, JG, LG, MG, NG, PG

Betriebsanleitung Instruções de Serviço	Operating Instructions İşletme kılavuzu	Instructions de service Инструкция по эксплуатации	Instructivo 使用说明	Istruzioni operative
<b>Deutsch</b>	<b>English</b>	<b>Français</b>		
Vor der Installation, dem Betrieb oder der Wartung des Geräts muss diese Anleitung gelesen und verstanden werden.	Read and understand these instructions before installing, operating, or maintaining the equipment.	Ne pas installer, utiliser ou intervenir sur cet équipement avant d'avoir lu et assimilé les présentes instructions et notamment les conseils de sécurité et mises en garde qui y figurent.		
 <b>⚠ GEFÄHR</b> <b>Gefährliche Spannung. Lebensgefahr oder schwere Verletzungsgefahr.</b> Vor Beginn der Arbeiten Anlage und Gerät spannungsfrei schalten.	 <b>⚠ DANGER</b> <b>Hazardous voltage. Will cause death or serious injury.</b> Turn off and lock out all power supplying this device before working on this device.	 <b>⚠ DANGER</b> <b>Tension électrique. Danger de mort ou risque de blessures graves.</b> Mettre hors tension avant d'intervenir sur l'appareil.		
<b>VORSICHT</b>	<b>CAUTION</b>	<b>PRUDENCE</b>		
Eine sichere Gerätefunktion ist nur mit zertifizierten Komponenten gewährleistet.	Reliable functioning of the equipment is only ensured with certified components.	La sécurité de fonctionnement de l'appareil n'est garantie qu'avec des composants certifiés.		
<b>Español</b>	<b>Italiano</b>	<b>Português</b>		
Leer y comprender este instructivo antes de la instalación, operación o mantenimiento del equipo.	Leggere con attenzione queste istruzioni prima di installare, utilizzare o eseguire manutenzione su questa apparecchiatura.	Ler e compreender estas instruções antes da instalação, operação ou manutenção do equipamento.		
 <b>⚠ PELIGRO</b> <b>Tensión peligrosa. Puede causar la muerte o lesiones graves.</b> Desconectar la alimentación eléctrica antes de trabajar en el equipo.	 <b>⚠ PERICOLO</b> <b>Tensione pericolosa. Può provocare morte o lesioni gravi.</b> Scollegare l'alimentazione prima di eseguire interventi sull'apparecchiatura.	 <b>⚠ PERIGO</b> <b>Tensão perigosa. Perigo de morte ou ferimentos graves.</b> Desligue a alimentação elétrica e proteja contra o religamento, antes de iniciar o trabalho no equipamento.		
<b>PRECAUCIÓN</b>	<b>CAUTELA</b>	<b>CUIDADO</b>		
El funcionamiento seguro del aparato sólo está garantizado con componentes certificados.	Il funzionamento sicuro dell'apparecchiatura è garantito soltanto con componenti certificati.	O funcionamento seguro do aparelho apenas pode ser garantido se forem utilizados os componentes certificados.		
<b>Türkçe</b>	<b>Русский</b>	<b>中文</b>		
Cihazın kurulumundan, çalıştırılmasından veya bakıma tabi tutulmasından önce, bu kılavuzun okunmuş ve anlaşılmış olması gerekmektedir.	Перед установкой, вводом в эксплуатацию или обслуживанием устройства необходимо прочесть и понять данное руководство.	安装、使用和维修本设备前必须先阅读并理解本说明。		
 <b>⚠ TEHLİKE</b> <b>Tehlikeli gerilim. Ölüm tehlikesi veya ağır yaralanma tehlikesi.</b> Çalışmalara başlamadan önce, sistemin ve cihazın gerilim beslemesini kapatınız.	 <b>⚠ ОПАСНО</b> <b>Опасное напряжение. Опасность для жизни или возможность тяжелых травм.</b> Перед началом работ отключить подачу питания к установке и к устройству.	 <b>⚠ 危险</b> <b>危险电压。可能导致生命危险或重伤危险。</b> 操作设备时必须确保切断电源。		
<b>ÖNEMLİ DİKKAT</b>	<b>ОСТОРОЖНО</b>	<b>小心</b>		
Cihazın güvenli çalışması ancak sertifikalı bileşenler kullanılması halinde garanti edilebilir.	Безопасность работы устройства гарантируется только при использовании сертифицированных компонентов.	只有使用经过认证的部件才能保证设备的正常运转。		
<b>Technical Support:</b> Internet: <a href="http://www.siemens.com/lowvoltage/technical-support">http://www.siemens.com/lowvoltage/technical-support</a>				

**Use only with Siemens certified Components.**  
**Utilizar únicamente con componentes certificados de Siemens.**  
**A utiliser uniquement avec les composants certifiés Siemens.**

**NOTE**

These instructions do not purport to cover all details or variations in equipment, or to provide for every possible contingency to be met in connection with installation, operation or maintenance. Should further information be desired or should particular problems arise, which are not covered sufficiently for the purchaser's purposes, the matter should be referred to the local Siemens sales office. The contents of this Instruction manual shall not become part of or modify any prior or existing agreement, commitment or relationship. The sales contract contains the entire obligation of Siemens. The warranty contained in the contract between the parties is the sole warranty of Siemens. Any statements contained herein do not create new warranties or modify the existing warranty.

Trademarks - Unless otherwise noted, all names identified by ® are registered trademarks of Siemens AG or Siemens Industry, Inc. The remaining trademarks in this publication may be trademarks whose use by third parties for their own purposes could violate the rights of the owner.

DE	Notwendige Werkzeuge für Montage
EN	Necessary assembly tools
FR	Outils nécessaires pour le montage
ES	Herramientas requeridas para el montaje
IT	Utensili necessari per il montaggio
PT	Ferramentas necessárias para a montagem
TR	Montaj için gerekli aletler
PY	Инструменты, необходимые для монтажа
中文	安装所需工具

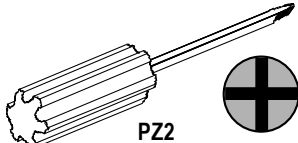

**PZ2**  
cal. ISO 6789

**3ZW1012-0VL02-2AA0**

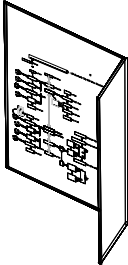

DE	Lieferumfang
EN	Quantity of delivery
FR	Composition de la fourniture
ES	Alcance del suministro
IT	Configurazione di fornitura
PT	Escopo de fornecimento
TR	Teslimat hacmi
PY	Комплект поставки
中文	供货范围

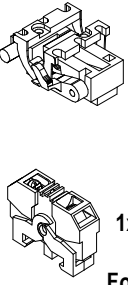

**U.S. Cat. No.**  
COMKIT3  
COMKIT6

**Order No.**  
3VL9300-8AQ61  
3VL9300-8AQ71

**1x**

**For Use With Frame DG, FG**  
**Para Usar Con Caja Base DG, FG**

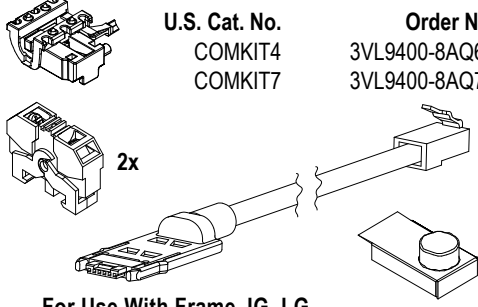

**U.S. Cat. No.**  
COMKIT4  
COMKIT7

**Order No.**  
3VL9400-8AQ61  
3VL9400-8AQ71

**2x**

**For Use With Frame JG, LG**  
**Para Usar Con Caja Base JG, LG**

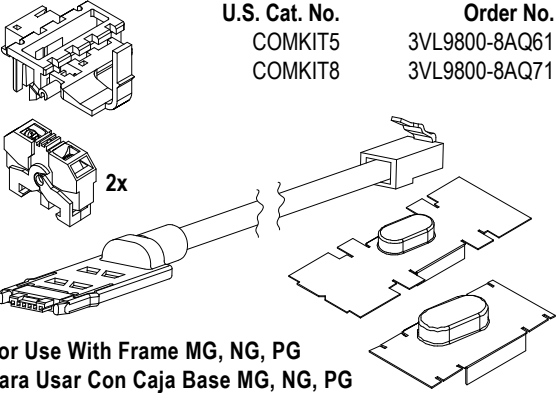



**U.S. Cat. No.**  
COMKIT5  
COMKIT8

**Order No.**  
3VL9800-8AQ61  
3VL9800-8AQ71

**2x**

**For Use With Frame MG, NG, PG**  
**Para Usar Con Caja Base MG, NG, PG**

⚠ DANGER		⚠ PELIGRO		⚠ DANGER	
	<b>Hazardous voltage.</b> Will cause death or serious injury.	<b>Tensión peligrosa.</b> Puede causar la muerte o lesiones graves.		<b>Tension électrique.</b> Danger de mort ou risque de blessures graves.	
	Turn off and lock out all power supplying this device before working on this device.	Desconectar la alimentación eléctrica antes de trabajar en el equipo.		Mettre hors tension avant d'intervenir sur l'appareil.	

DE	Montage	ES	Montaje	TR	Montaj
EN	Assembly	IT	Montaggio	PY	Монтаж
FR	Montage	PT	Montagem	中文	安装

**COMPRO20 / COMMOD21**  
Applications - Steps 1-10 [Refiérase al paso 1-10]

1

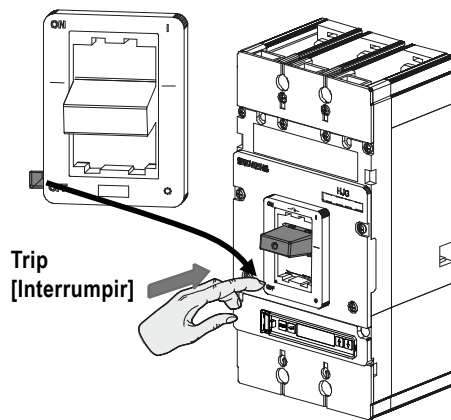

2

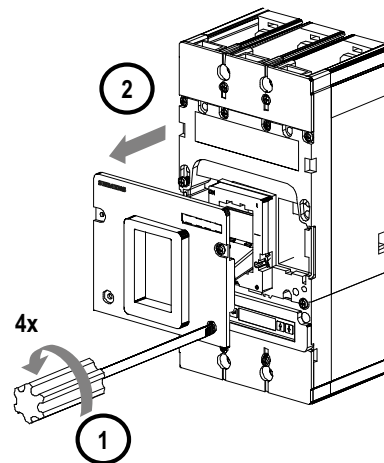

3

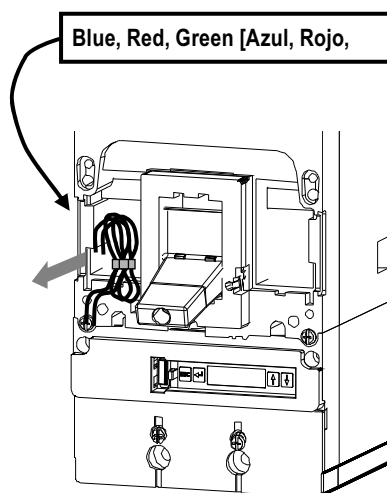

4

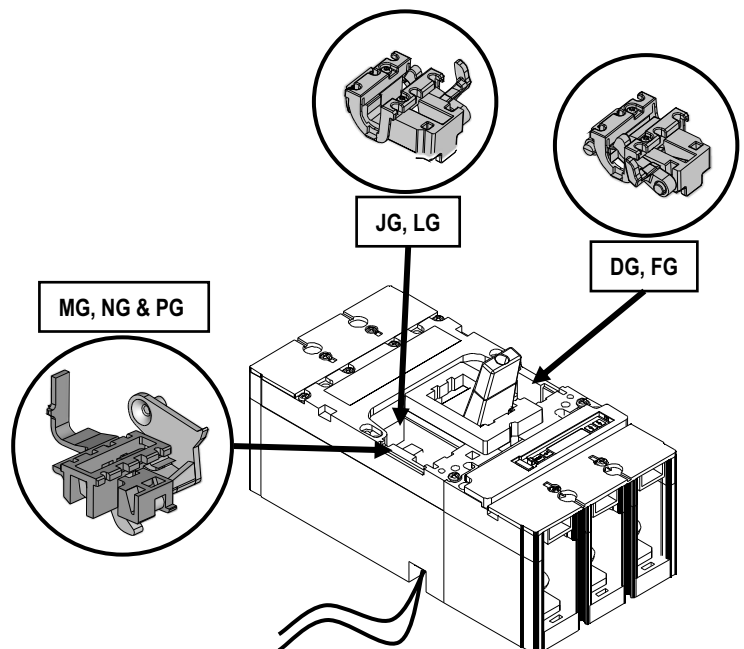

5a

DG, FG

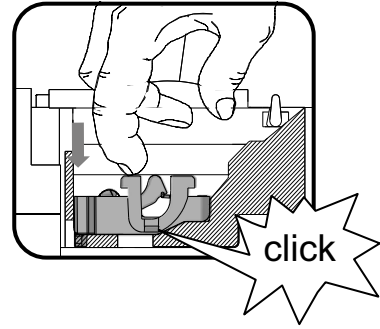
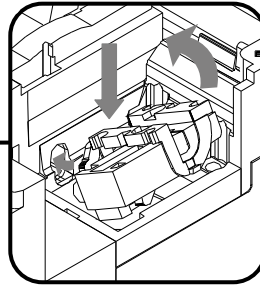
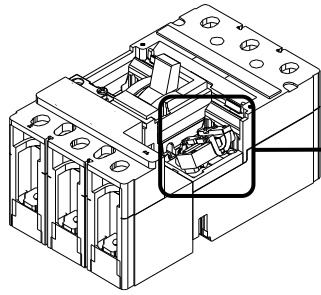

5b

JG, LG

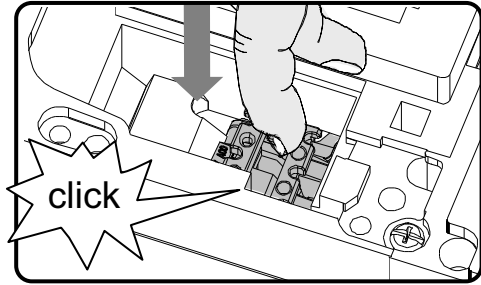
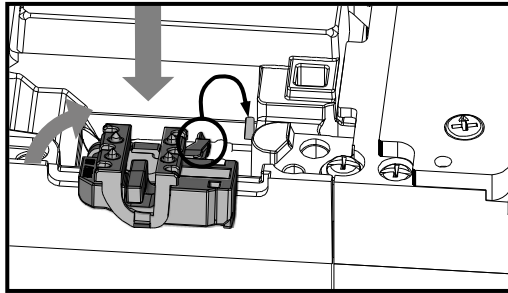

5c

MG, NG & PG

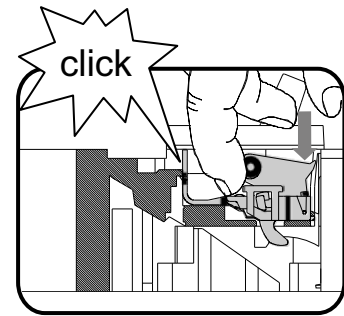
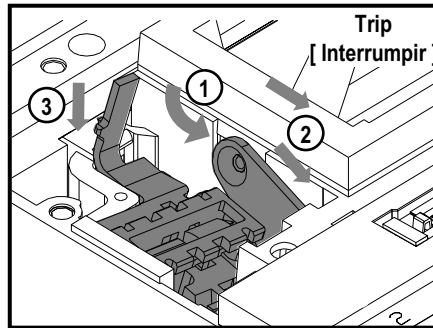
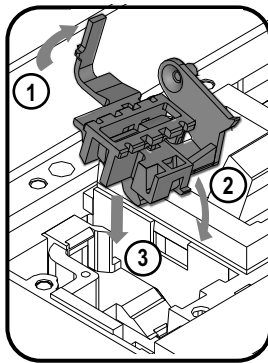

6

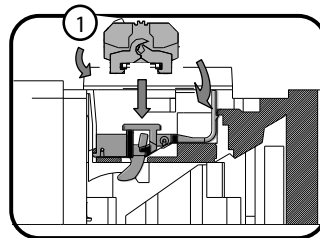
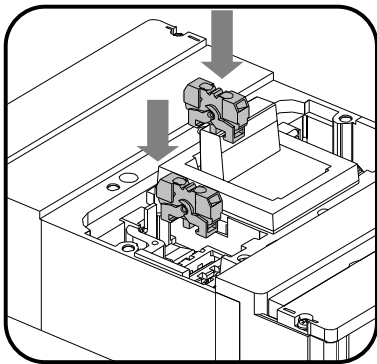

DG, FG

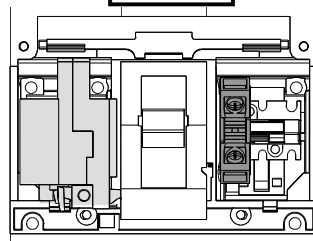

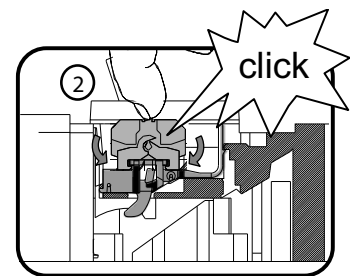
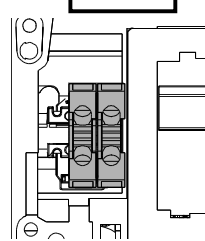

JG, LG

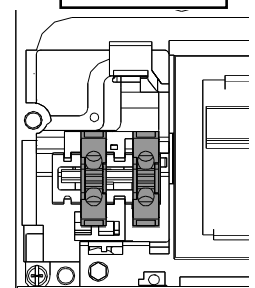

MG, NG & PG



⚠ DANGER	⚠ PELIGRO	⚠ DANGER
 <b>Hazardous voltage.</b> Will cause death or serious injury.	<b>Tensión peligrosa.</b> Puede causar la muerte o lesiones graves.	<b>Tension électrique.</b> Danger de mort ou risque de blessures graves.
 Turn off and lock out all power supplying this device before working on this device.	Desconectar la alimentación eléctrica antes de trabajar en el equipo.	Mettre hors tension avant d'intervenir sur l'appareil.

7a

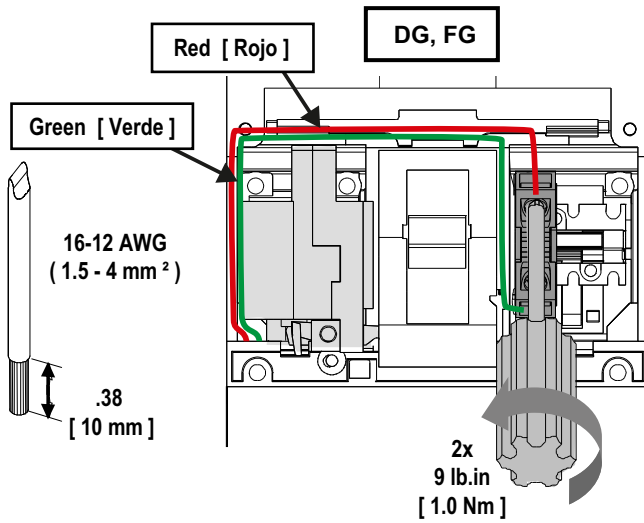

7b

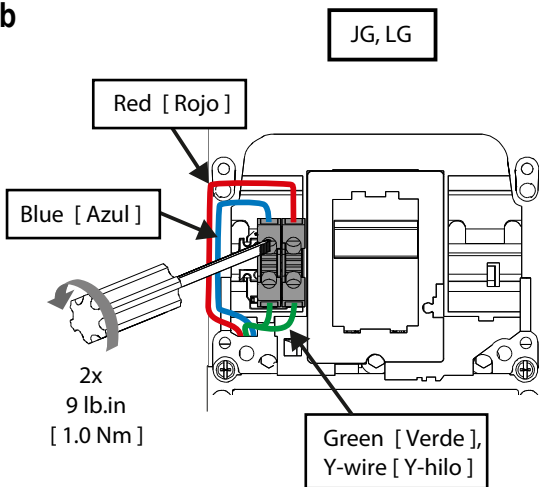

7c

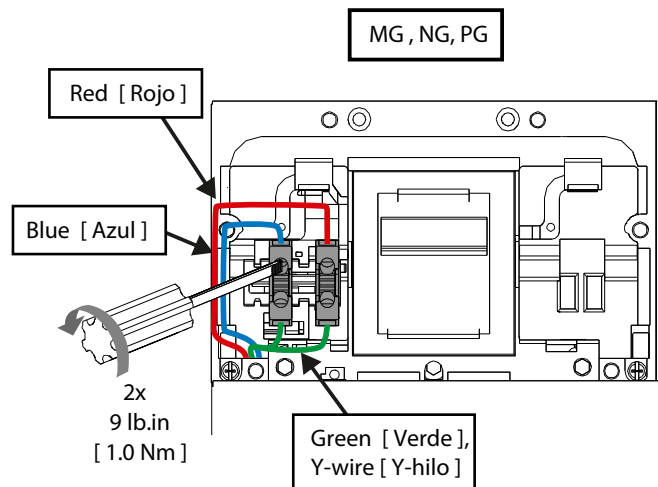

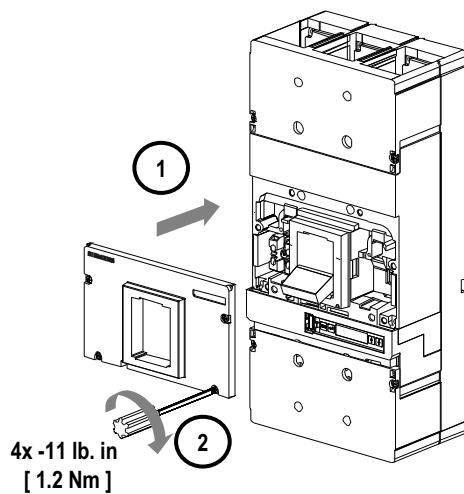

8

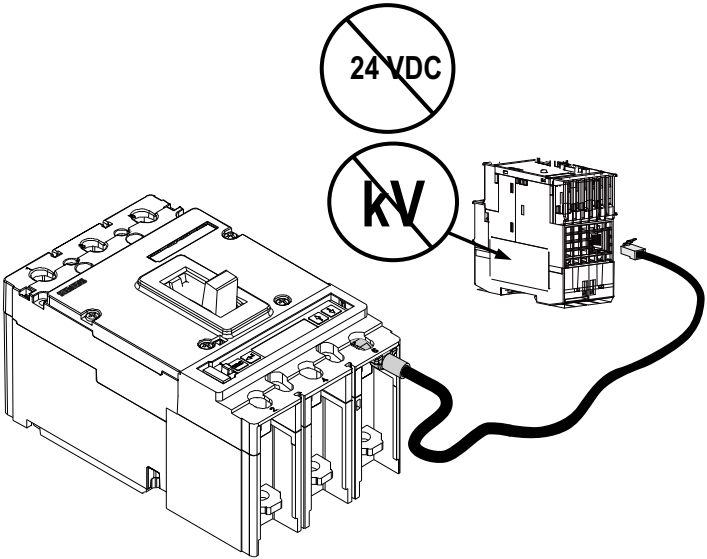
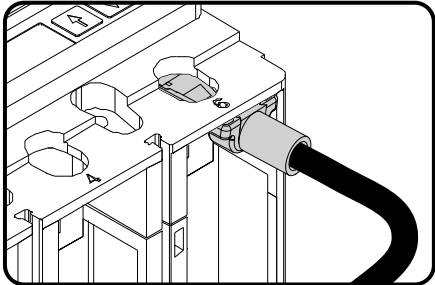
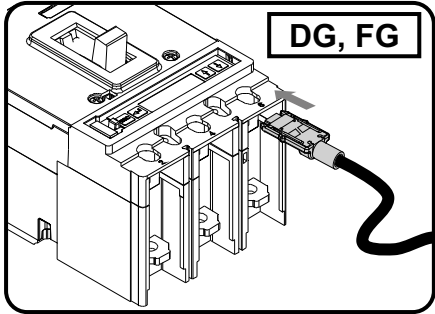
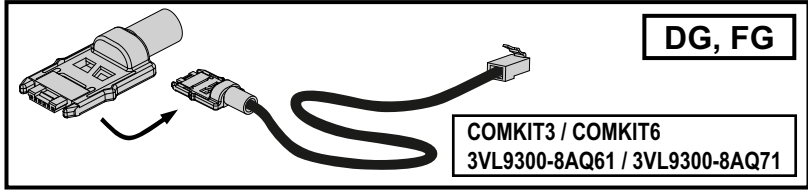

COMPRO20 / COMMOD21 Applications - Steps 1 - 10 [ Refiérase al paso 1 - 10 ]



<b>⚠ DANGER</b>	<b>⚠ PELIGRO</b>	<b>⚠ DANGER</b>
 <b>Hazardous voltage.</b> Will cause death or serious injury.	<b>Tensión peligrosa.</b> Puede causar la muerte o lesiones graves.	<b>Tension électrique.</b> Danger de mort ou risque de blessures graves.
 Turn off and lock out all power supplying this device before working on this device.	Desconectar la alimentación eléctrica antes de trabajar en el equipo.	Mettre hors tension avant d'intervenir sur l'appareil.

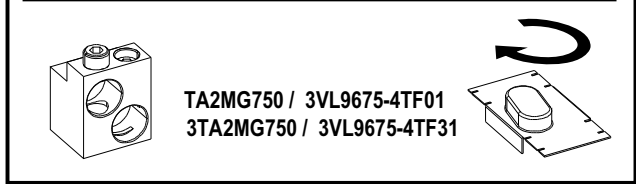
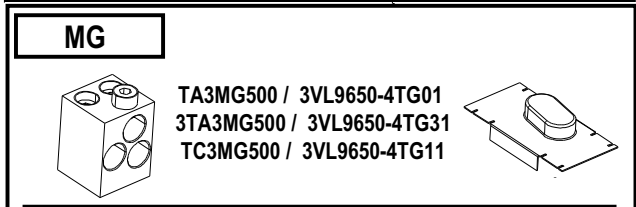
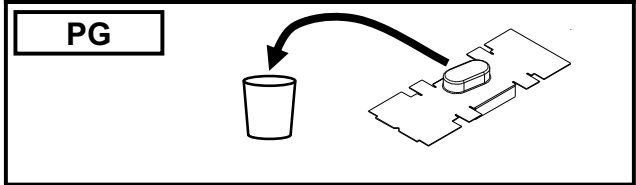
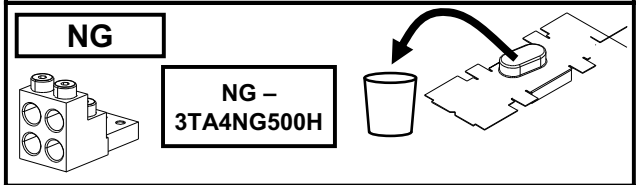
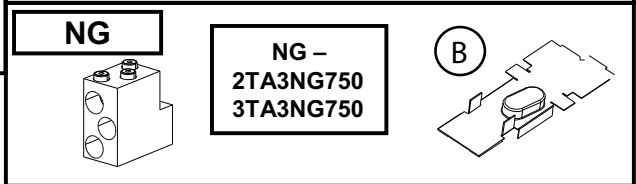
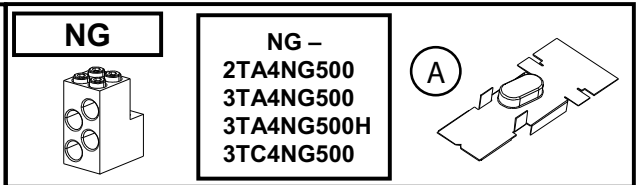
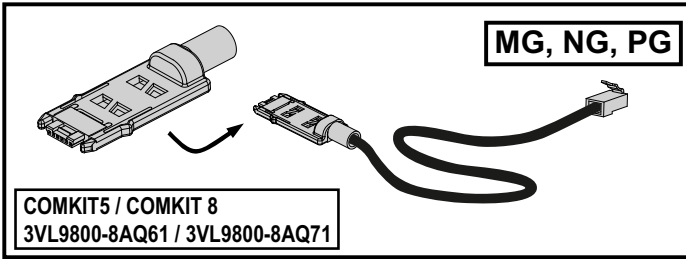

9b

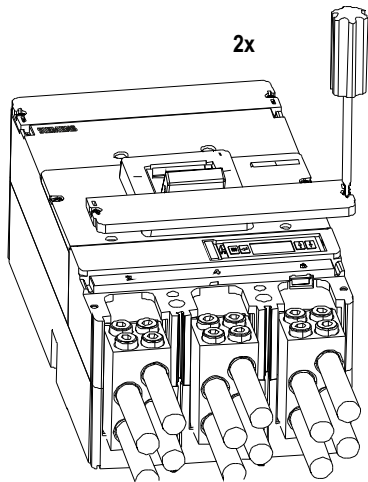

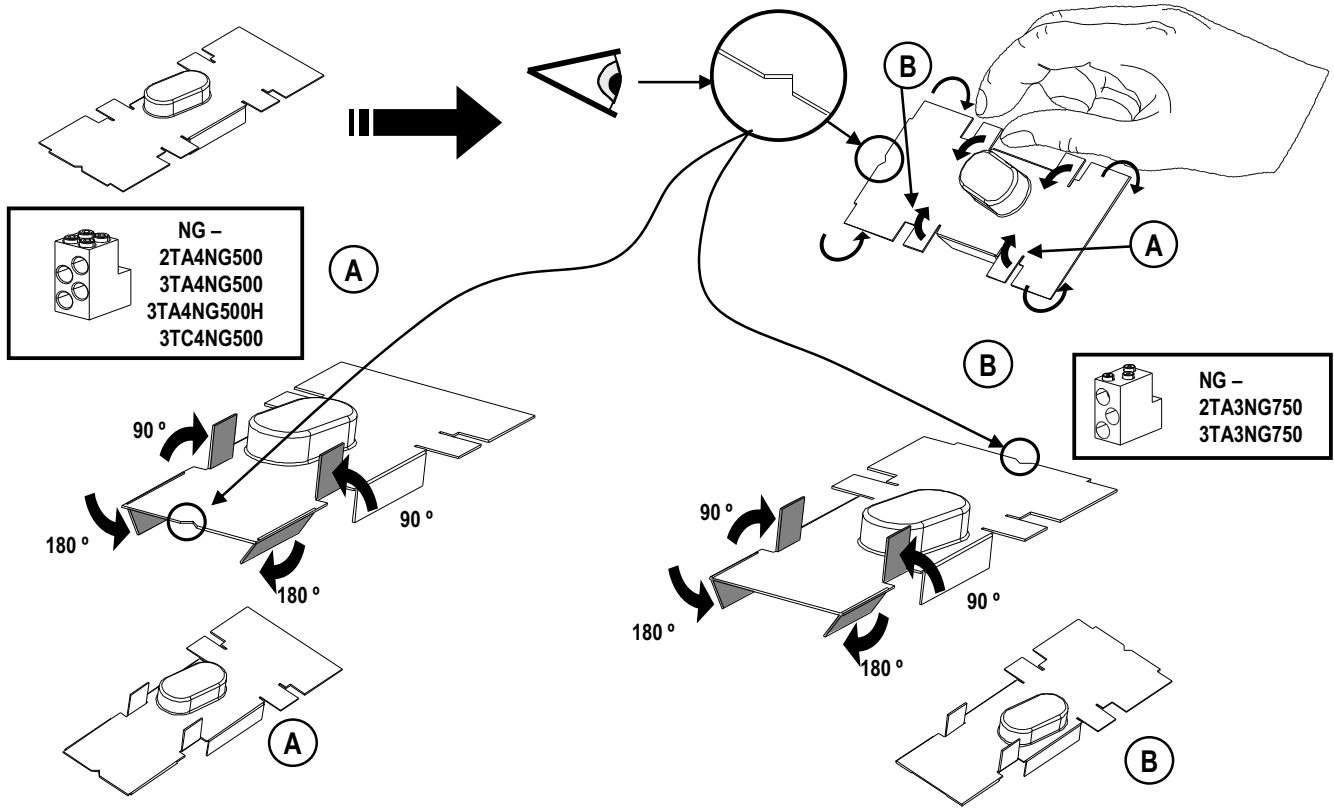

9c

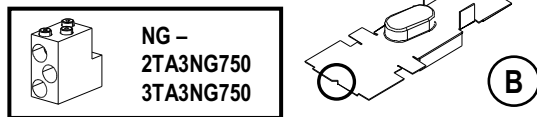

9d





⚠ DANGER	⚠ PELIGRO	⚠ DANGER
 <p><b>Hazardous voltage.</b> Will cause death or serious injury.</p>	<p><b>Tensión peligrosa.</b> Puede causar la muerte o lesiones graves.</p>	<p><b>Tension électrique.</b> Danger de mort ou risque de blessures graves.</p>
 <p>Turn off and lock out all power supplying this device before working on this device.</p>	<p>Desconectar la alimentación eléctrica antes de trabajar en el equipo.</p>	<p>Mettre hors tension avant d'intervenir sur l'appareil.</p>

9e

Example / ejemplo:

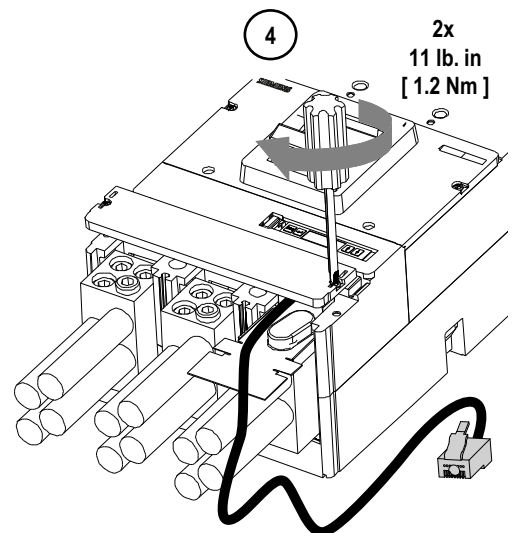
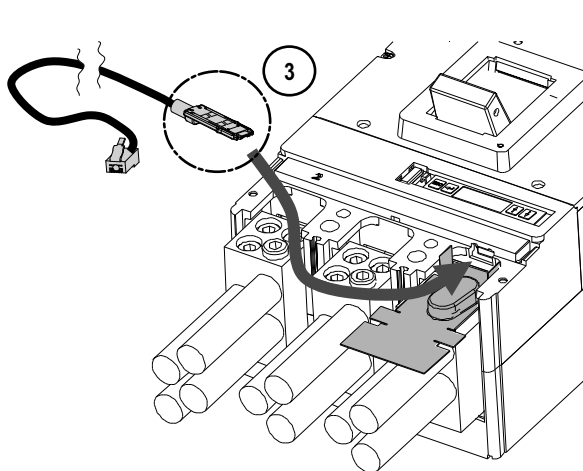
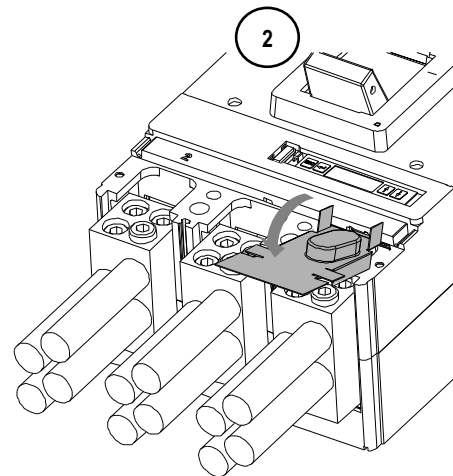
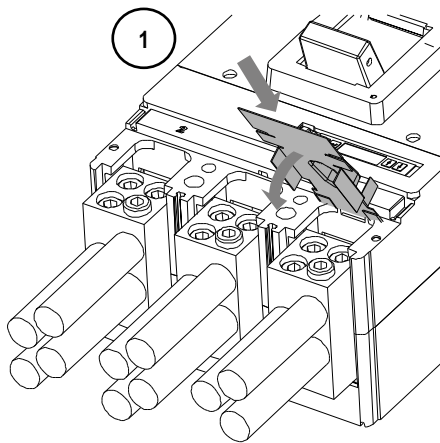
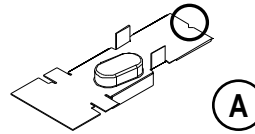
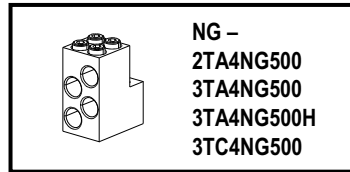

# MG

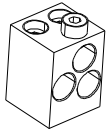

TA3MG500 / 3VL9650-4TG01  
3TA3MG500 / 3VL9650-4TG31  
TC3MG500 / 3VL9650-4TG11

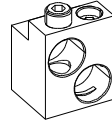
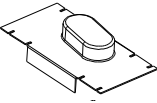

TA2MG750 / 3VL9675-4TF01  
3TA2MG750 / 3VL9675-4TF31

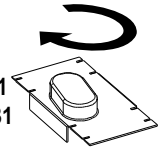

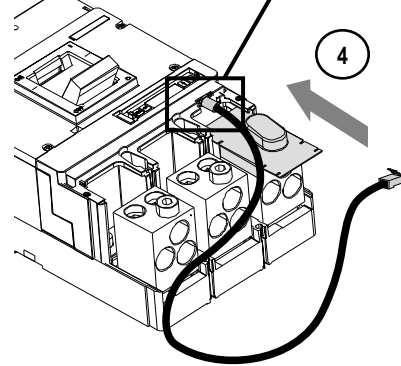
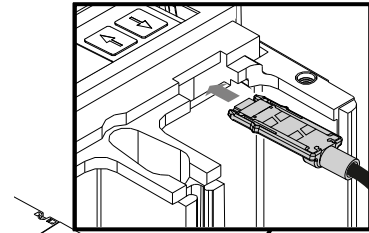
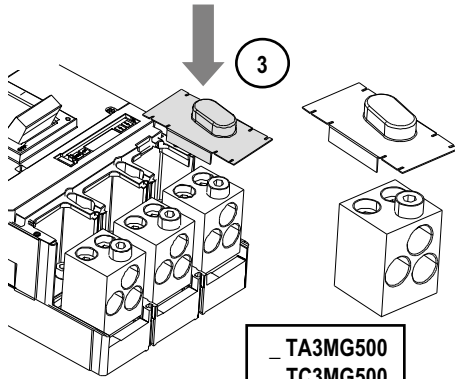
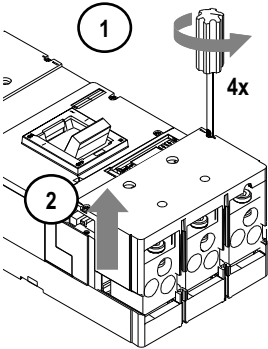

9f

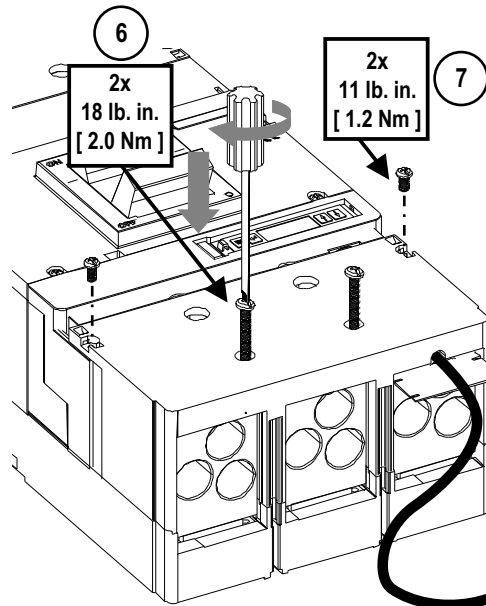
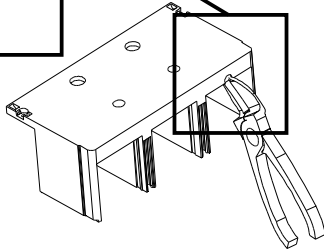
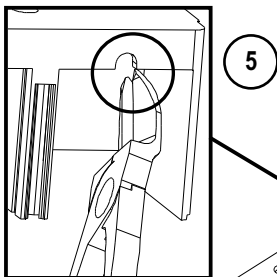
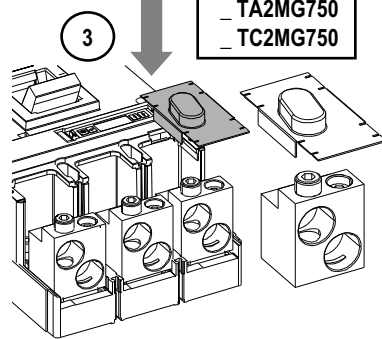

— TA3MG500  
— TC3MG500

— TA2MG750  
— TC2MG750



<b>⚠ DANGER</b>	<b>⚠ PELIGRO</b>	<b>⚠ DANGER</b>
 <b>Hazardous voltage.</b> <b>Will cause death or serious injury.</b>	<b>Tensión peligrosa.</b> <b>Puede causar la muerte o lesiones graves.</b>	<b>Tension électrique.</b> <b>Danger de mort ou risque de blessures graves.</b>
 Turn off and lock out all power supplying this device before working on this device.	Desconectar la alimentación eléctrica antes de trabajar en el equipo.	Mettre hors tension avant d'intervenir sur l'appareil.

**COMPRO20 / COMMOD21 Applications - Steps 1-10 [ Refiérase al paso 1-10 ]**

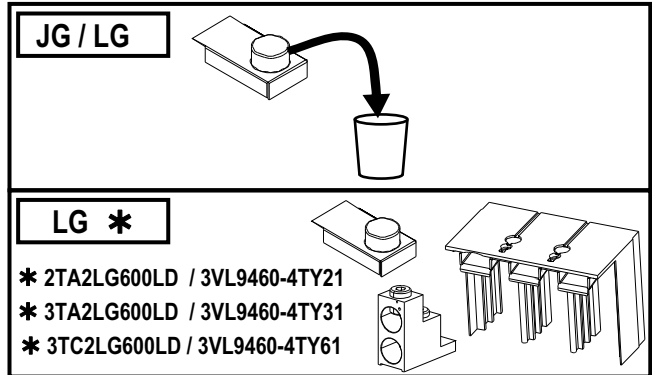

**10a**

**Example [ejemplo]: LG**

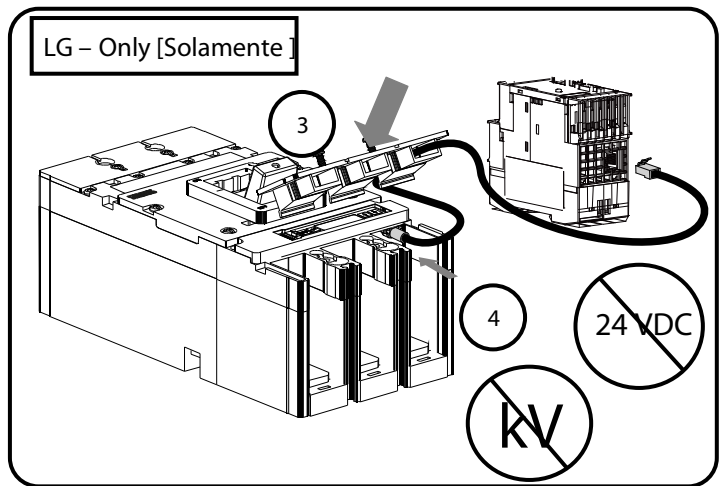
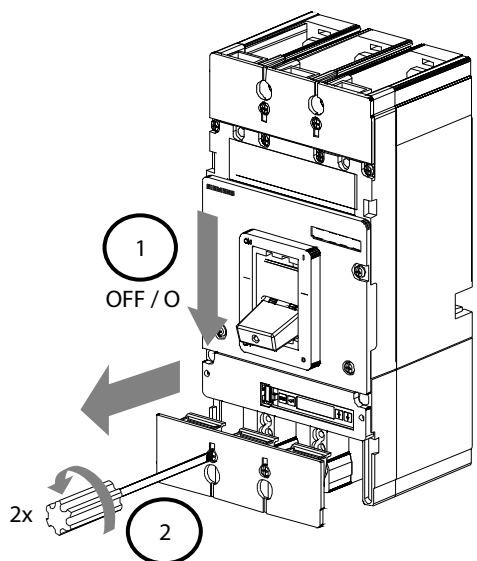

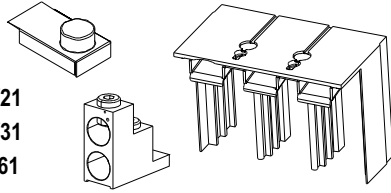

**LG \***

- \* 2TA2LG600LD / 3VL9460-4TY21
- \* 3TA2LG600LD / 3VL9460-4TY31
- \* 3TC2LG600LD / 3VL9460-4TY61

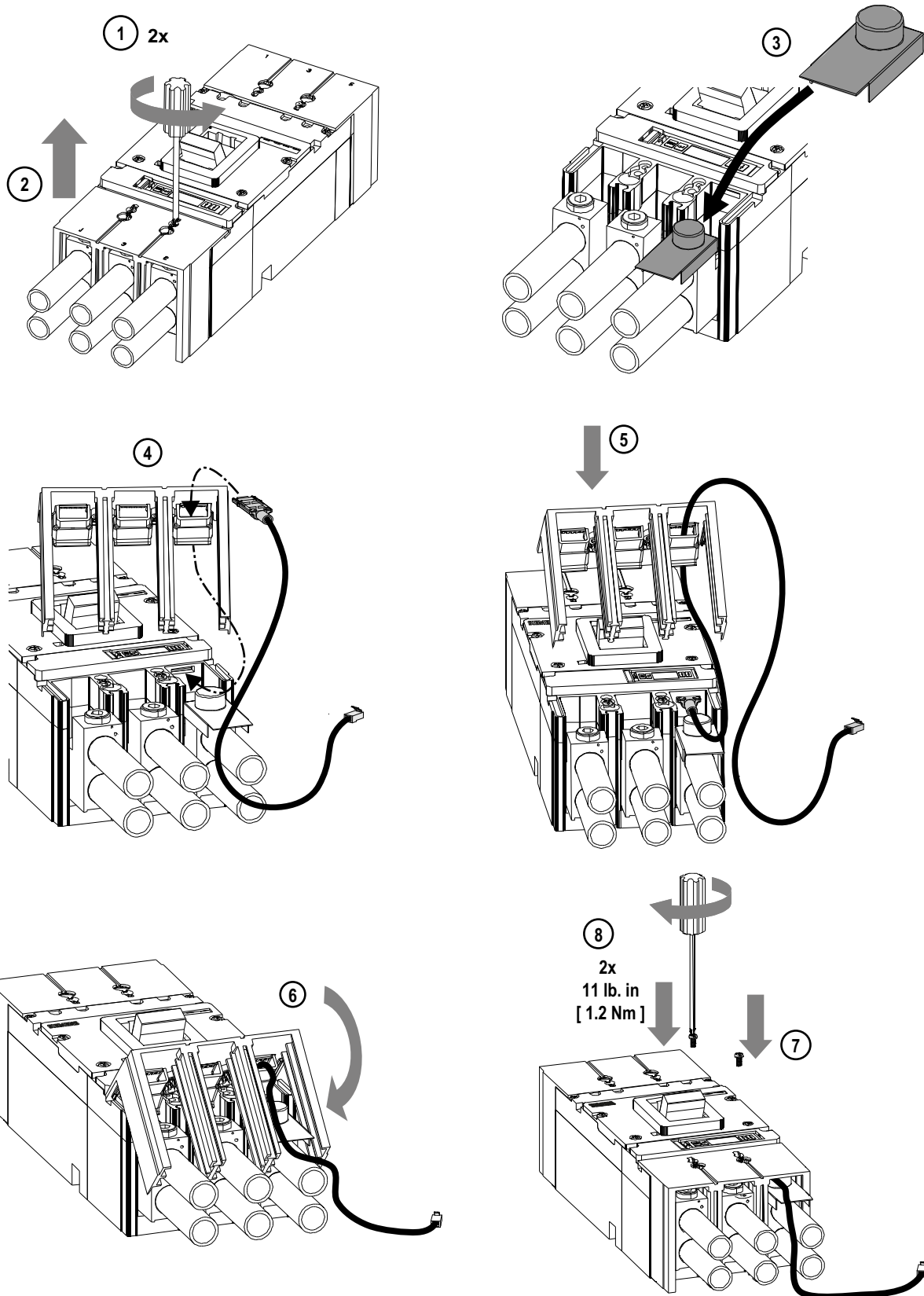

10b



⚠ DANGER	⚠ PELIGRO	⚠ DANGER
 <p><b>Hazardous voltage.</b> Will cause death or serious injury. Turn off and lock out all power supplying this device before working on this device.</p>	<p><b>Tensión peligrosa.</b> Puede causar la muerte o lesiones graves. Desconectar la alimentación eléctrica antes de trabajar en el equipo.</p>	<p><b>Tension électrique.</b> Danger de mort ou risque de blessures graves. Mettre hors tension avant d'intervenir sur l'appareil.</p>

Option:  
Opción:

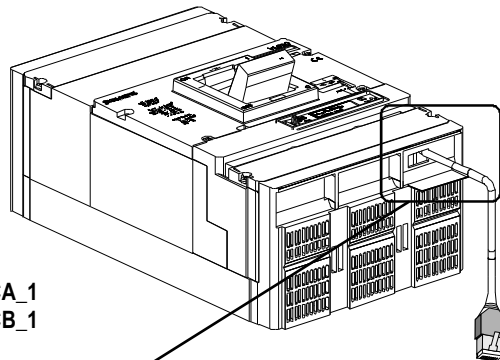

TSL\_\_ | 3VL9\_00-8CA\_1  
TSS\_\_ | 3VL9\_00-8CB\_1

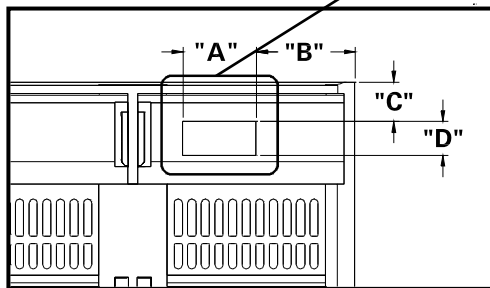

	"A"	"B"	"C"	"D"
DG / FG	.79" [ 20 mm ]	.26" [ 6.5 mm ]	.22" [ 5.5 mm ]	.51" [ 13 mm ]
JG / LG	.79" [ 20 mm ]	.49" [ 12.5 mm ]	.16" [ 4 mm ]	.35" [ 9 mm ]
MG	.79" [ 20 mm ]	.89" [ 22.5 mm ]	.26" [ 6.5 mm ]	.35" [ 9 mm ]
NG / PG	.79" [ 20 mm ]	.92" [ 23.5 mm ]	1.97" [ 50 mm ]	.51" [ 13 mm ]

DE	Weitere Informationen finden Sie im 3VL-Handbuch im Internet unter: <a href="http://www.siemens.com/lowvoltage/manuals">www.siemens.com/lowvoltage/manuals</a> <a href="http://www.usa.siemens.com/powerdistribution">www.usa.siemens.com/powerdistribution</a> (nur in Deutsch und Englisch)
EN	Further information can be found in the 3VL manual on the internet at <a href="http://www.siemens.com/lowvoltage/manuals">www.siemens.com/lowvoltage/manuals</a> <a href="http://www.usa.siemens.com/powerdistribution">www.usa.siemens.com/powerdistribution</a> (only in German and English)
FR	Vous trouverez des informations supplémentaires dans le manuel 3VL sur le site Internet <a href="http://www.siemens.com/lowvoltage/manuals">www.siemens.com/lowvoltage/manuals</a> <a href="http://www.usa.siemens.com/powerdistribution">www.usa.siemens.com/powerdistribution</a> (seulement en allemand et en anglais)
ES	Para más información, consulte el manual 3VL que está disponible en nuestra página web <a href="http://www.siemens.com/lowvoltage/manuals">www.siemens.com/lowvoltage/manuals</a> <a href="http://www.usa.siemens.com/powerdistribution">www.usa.siemens.com/powerdistribution</a> (sólo en alemán e inglés)
IT	Ulteriori informazioni sono disponibili in Internet nel manuale 3VL su <a href="http://www.siemens.com/lowvoltage/manuals">www.siemens.com/lowvoltage/manuals</a> <a href="http://www.usa.siemens.com/powerdistribution">www.usa.siemens.com/powerdistribution</a> (solo in tedesco e in inglese)
PT	Mais informações encontram-se no manual 3VL na Internet, sob <a href="http://www.siemens.com/lowvoltage/manuals">www.siemens.com/lowvoltage/manuals</a> <a href="http://www.usa.siemens.com/powerdistribution">www.usa.siemens.com/powerdistribution</a> (somente em alemão e em inglês)
TR	Ayrıntılı bilgiyi aşağıdaki internet adresindeki 3VL kullanma kılavuzundan edinebilirsiniz: <a href="http://www.siemens.com/lowvoltage/manuals">www.siemens.com/lowvoltage/manuals</a> <a href="http://www.usa.siemens.com/powerdistribution">www.usa.siemens.com/powerdistribution</a> (sadece Almanca ve İngilizce olarak)
PY	Дальнейшую информацию Вы сможете найти в инструкции по эксплуатации 3VL в интернете по адресу: <a href="http://www.siemens.com/lowvoltage/manuals">www.siemens.com/lowvoltage/manuals</a> <a href="http://www.usa.siemens.com/powerdistribution">www.usa.siemens.com/powerdistribution</a> (только на немецком и английском языке)
中文	其他相关信息参见 3VL 使用手册，请登陆互联网： <a href="http://www.siemens.com/lowvoltage/manuals">www.siemens.com/lowvoltage/manuals</a> （德、英文）