

SIEMENS

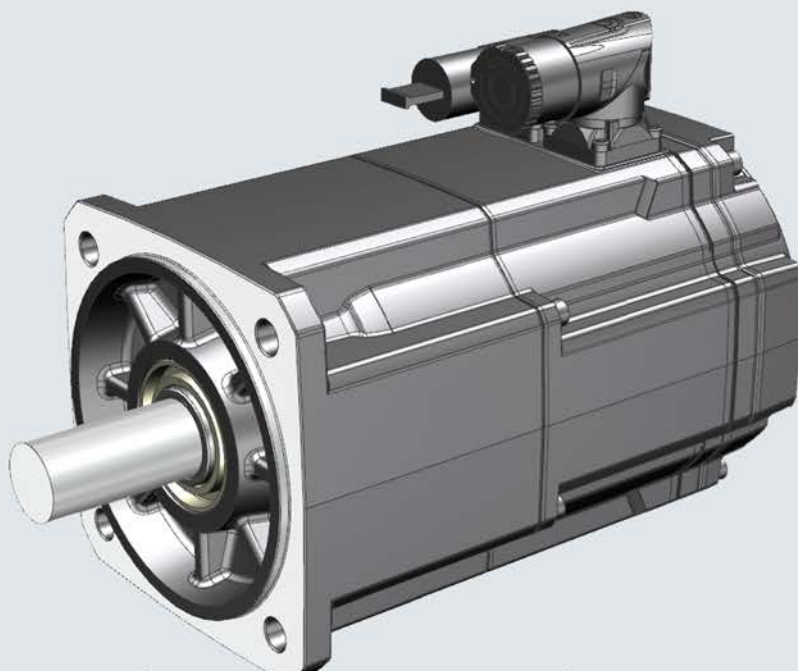

Operating Instructions

SIMOTICS

SIMOTICS S-1FK2 synchronous motors

For SINAMICS S120

Edition

12/2018

www.siemens.com

SIMOTICS

Drive technology SIMOTICS S-1FK2 for S120 synchronous motors

Operating Instructions

Introduction

Fundamental safety instructions for the SIMOTICS documentation **1**

Description of the motors **2**

Mounting and options **3**

Preparing for use **4**

Mounting **5**

Connecting **6**

Commissioning **7**

Operation **8**

Faults and their rectification **9**

Maintenance **10**

Decommissioning and disposal **11**



Technical data and characteristics **12**

Dimension drawings **13**

Legal information

Warning notice system

This manual contains notices you have to observe in order to ensure your personal safety, as well as to prevent damage to property. The notices referring to your personal safety are highlighted in the manual by a safety alert symbol, notices referring only to property damage have no safety alert symbol. These notices shown below are graded according to the degree of danger.

 DANGER
indicates that death or severe personal injury will result if proper precautions are not taken.
 WARNING
indicates that death or severe personal injury may result if proper precautions are not taken.
 CAUTION
indicates that minor personal injury can result if proper precautions are not taken.
NOTICE
indicates that property damage can result if proper precautions are not taken.

If more than one degree of danger is present, the warning notice representing the highest degree of danger will be used. A notice warning of injury to persons with a safety alert symbol may also include a warning relating to property damage.

Qualified Personnel

The product/system described in this documentation may be operated only by **personnel qualified** for the specific task in accordance with the relevant documentation, in particular its warning notices and safety instructions. Qualified personnel are those who, based on their training and experience, are capable of identifying risks and avoiding potential hazards when working with these products/systems.

Proper use of Siemens products

Note the following:

 WARNING
Siemens products may only be used for the applications described in the catalog and in the relevant technical documentation. If products and components from other manufacturers are used, these must be recommended or approved by Siemens. Proper transport, storage, installation, assembly, commissioning, operation and maintenance are required to ensure that the products operate safely and without any problems. The permissible ambient conditions must be complied with. The information in the relevant documentation must be observed.

Trademarks

All names identified by ® are registered trademarks of Siemens AG. The remaining trademarks in this publication may be trademarks whose use by third parties for their own purposes could violate the rights of the owner.

Disclaimer of Liability

We have reviewed the contents of this publication to ensure consistency with the hardware and software described. Since variance cannot be precluded entirely, we cannot guarantee full consistency. However, the information in this publication is reviewed regularly and any necessary corrections are included in subsequent editions.

Introduction

Keeping the documentation safe

This documentation should be kept in a location where it can be easily accessed and made available to the personnel responsible.

Target group and use

Target group

These Operating Instructions are intended for installation engineers, commissioners, machine operators, and service and maintenance personnel.

Utilization phase

Planning and engineering phase, implementation phase, installation and commissioning phase, application phase, maintenance and service phase.

About these operating instructions

These operating instructions apply to the SIMOTICS S-1FK2 servo motor, referred to as "1FK2" in this document.

The Operating Instructions provide information about the components that enable the target group to install, set up, test, commission, operate, and troubleshoot the products and systems correctly and safely.

The operating instructions inform you about how to handle the 1FK2 from delivery to final disposal.

You will find additional information in the configuration manual for the 1FK2.

Before you start using the motor, you must read these Operating Instructions to ensure safe, problem-free operation and to maximize the service life.

Siemens strives continually to improve the quality of information provided in these Operating Instructions.

- If you find any mistakes or would like to offer suggestions about how this document could be improved, contact the Siemens Service Center.
- Always follow the safety instructions and notices in this Product Information.

The warning notice system is explained on the rear of the inside front.

Text features

In addition to the notes that you must observe for your own personal safety as well as to avoid material damage, in this document you will find the following text features:

Operating instructions

Handling instructions with a specified sequence start with the word "Procedure":

The individual handling steps are numbered.

1. Execute the operating instructions in the specified sequence.



The square indicates the end of the operating instruction.

Operating instructions without a specified sequence are identified using a bullet point:

- Execute the operating instructions.

Enumerations

- Enumerations are identified by a bullet point without any additional symbols.
 - Enumerations at the second level are hyphenated.

Notes

Notes are shown as follows:

Note

A Note is an important item of information about the product, handling of the product or the relevant section of the document. Notes provide you with help or further suggestions/ideas.

More information

Information on the following topics is available at:

- Ordering documentation / overview of documentation
- Additional links to download documents
- Using documentation online (find and search in manuals / information)

More information (<https://support.industry.siemens.com/cs/de/en/view/108998034>)

If you have any questions regarding the technical documentation (e.g. suggestions, corrections), please send an e-mail to the following address E-mail (<mailto:docu.motioncontrol@siemens.com>).

My support

The following link provides information on how to create your own individual documentation based on Siemens content, and adapt it for your own machine documentation:

My support (<https://support.industry.siemens.com/My/de/en/documentation>)

Note

If you want to use this function, you must first register.

Later, you can log on with your login data.

Training

The following link provides information on SITRAIN - training from Siemens for products, systems and automation engineering solutions:

SITRAIN (<http://siemens.com/sitrain>)

Technical Support

Country-specific telephone numbers for technical support are provided on the Internet under Contact:

Technical Support (<https://support.industry.siemens.com/sc/ww/en/sc/2090>)

Internet address for products

Products (<http://www.siemens.com/motioncontrol>)

Websites of third parties

This publication contains hyperlinks to websites of third parties. Siemens does not take any responsibility for the contents of these websites or adopt any of these websites or their contents as their own, because Siemens does not control the information on these websites and is also not responsible for the contents and information provided there. Use of these websites is at the risk of the person doing so.

Table of contents

	Introduction	3
1	Fundamental safety instructions for the SIMOTICS documentation.....	11
1.1	Fundamental safety instructions	11
1.1.1	General safety instructions	11
1.1.2	Equipment damage due to electric fields or electrostatic discharge	16
1.1.3	Industrial security	17
1.1.4	Residual risks of power drive systems.....	19
2	Description of the motors	21
2.1	Use for the intended purpose	21
2.2	Technical features and environmental conditions	22
2.2.1	Directives and standards	22
2.2.2	General technical features	24
2.2.3	Environmental conditions.....	25
2.2.4	Degree of protection	26
2.2.5	Noise emission.....	26
2.3	Structure of the article number	27
2.4	Rating plate data.....	29
3	Mounting and options.....	31
3.1	Safety symbols on the motor	31
3.2	Shaft extension	31
3.3	Bearing version	32
3.4	Permissible radial and axial forces	32
3.5	Thermal motor protection.....	32
3.6	Encoder.....	33
3.7	Cooling.....	33
3.8	Holding brake	34
4	Preparing for use	37
4.1	Shipping and packaging	37
4.2	Transportation and storage.....	38
4.2.1	Transport.....	38
4.2.2	Storage	41
5	Mounting.....	43
5.1	Safety instructions.....	43
5.2	Checklists prior to mounting	45
5.3	Mounting instructions	46

5.4	Mounting the drive elements.....	47
5.5	Vibration response	49
6	Connecting	51
6.1	Safety instructions.....	51
6.2	Permissible line system types.....	52
6.3	System integration	52
6.3.1	Connection notes	52
6.3.1.1	Motor connection.....	52
6.3.1.2	Rotating the connector on the motor	54
6.3.1.3	Routing cables in a damp environment	57
6.3.2	Line connection	58
6.3.3	Signal connection.....	58
6.3.4	Connecting to a converter	59
7	Commissioning	65
7.1	Safety instructions.....	65
7.2	Checklists for commissioning.....	68
7.3	Commissioning procedure	70
7.4	Switching on and switching off.....	71
8	Operation.....	73
8.1	Safety instructions.....	73
8.2	Switching on and switching off.....	74
8.3	During operation.....	74
8.4	Stoppages	75
8.5	Cleaning	75
9	Faults and their rectification	77
10	Maintenance	79
10.1	Safety instructions.....	79
10.2	Inspection and maintenance	82
10.2.1	Service and inspection intervals	82
10.2.2	Cleaning	83
10.2.3	Motor replacement on reaching the bearing life	83
10.3	Repair.....	84
10.3.1	How to replace a 1FK2 motor	84
11	Decommissioning and disposal	87
11.1	Safety instructions.....	87
11.2	Decommissioning.....	88
11.2.1	Removing the motor.....	88
11.2.2	Dismantling the motor	88
11.3	Disposal	88

12	Technical data and characteristics	89
13	Dimension drawings.....	91
	Index.....	93

Fundamental safety instructions for the SIMOTICS documentation

1

1.1 Fundamental safety instructions

1.1.1 General safety instructions



WARNING

Electric shock and danger to life due to other energy sources

Touching live components can result in death or severe injury.

- Only work on electrical devices when you are qualified for this job.
- Always observe the country-specific safety rules.

Generally, the following six steps apply when establishing safety:

1. Prepare for disconnection. Notify all those who will be affected by the procedure.
2. Isolate the drive system from the power supply and take measures to prevent it being switched back on again.
3. Wait until the discharge time specified on the warning labels has elapsed.
4. Check that there is no voltage between any of the power connections, and between any of the power connections and the protective conductor connection.
5. Check whether the existing auxiliary supply circuits are de-energized.
6. Ensure that the motors cannot move.
7. Identify all other dangerous energy sources, e.g. compressed air, hydraulic systems, or water. Switch the energy sources to a safe state.
8. Check that the correct drive system is completely locked.

After you have completed the work, restore the operational readiness in the inverse sequence.



WARNING

Electric shock due to connection to an unsuitable power supply

When equipment is connected to an unsuitable power supply, exposed components may carry a hazardous voltage that might result in serious injury or death.

- Only use power supplies that provide SELV (Safety Extra Low Voltage) or PELV- (Protective Extra Low Voltage) output voltages for all connections and terminals of the electronics modules.



! WARNING

Electric shock due to damaged motors or devices

Improper handling of motors or devices can damage them.

Hazardous voltages can be present at the enclosure or at exposed components on damaged motors or devices.

- Ensure compliance with the limit values specified in the technical data during transport, storage and operation.
- Do not use any damaged motors or devices.



! WARNING

Electric shock due to unconnected cable shield

Hazardous touch voltages can occur through capacitive cross-coupling due to unconnected cable shields.

- As a minimum, connect cable shields and the conductors of power cables that are not used (e.g. brake cores) at one end at the grounded housing potential.



! WARNING

Electric shock if there is no ground connection

For missing or incorrectly implemented protective conductor connection for devices with protection class I, high voltages can be present at open, exposed parts, which when touched, can result in death or severe injury.

- Ground the device in compliance with the applicable regulations.



! WARNING

Arcing when a plug connection is opened during operation

Opening a plug connection when a system is operation can result in arcing that may cause serious injury or death.

- Only open plug connections when the equipment is in a voltage-free state, unless it has been explicitly stated that they can be opened in operation.

NOTICE**Property damage due to loose power connections**

Insufficient tightening torques or vibration can result in loose power connections. This can result in damage due to fire, device defects or malfunctions.

- Tighten all power connections to the prescribed torque.
- Check all power connections at regular intervals, particularly after equipment has been transported.

 **WARNING****Unexpected movement of machines caused by radio devices or mobile phones**

When radio devices or mobile phones with a transmission power > 1 W are used in the immediate vicinity of components, they may cause the equipment to malfunction.

Malfunctions may impair the functional safety of machines and can therefore put people in danger or lead to property damage.

- If you come closer than around 2 m to such components, switch off any radios or mobile phones.
- Use the "SIEMENS Industry Online Support app" only on equipment that has already been switched off.

 **WARNING****Unrecognized dangers due to missing or illegible warning labels**

Dangers might not be recognized if warning labels are missing or illegible. Unrecognized dangers may cause accidents resulting in serious injury or death.

- Check that the warning labels are complete based on the documentation.
- Attach any missing warning labels to the components, where necessary in the national language.
- Replace illegible warning labels.

 **WARNING**

Unexpected movement of machines caused by inactive safety functions

Inactive or non-adapted safety functions can trigger unexpected machine movements that may result in serious injury or death.

- Observe the information in the appropriate product documentation before commissioning.
- Carry out a safety inspection for functions relevant to safety on the entire system, including all safety-related components.
- Ensure that the safety functions used in your drives and automation tasks are adjusted and activated through appropriate parameterizing.
- Perform a function test.
- Only put your plant into live operation once you have guaranteed that the functions relevant to safety are running correctly.

Note

Important safety notices for Safety Integrated functions

If you want to use Safety Integrated functions, you must observe the safety notices in the Safety Integrated manuals.

 **WARNING**

Active implant malfunctions due to electromagnetic fields

Electromagnetic fields (EMF) are generated by the operation of electrical power equipment, such as transformers, converters, or motors. People with pacemakers or implants are at particular risk in the immediate vicinity of this equipment.

- If you have a heart pacemaker or implant, maintain the minimum distance specified in chapter "Correct usage" from such motors.

 **WARNING**

Active implant malfunctions due to permanent-magnet fields

Even when switched off, electric motors with permanent magnets represent a potential risk for persons with heart pacemakers or implants if they are close to converters/motors.

- If you have a heart pacemaker or implant, maintain the minimum distance specified in chapter "Correct usage".
- When transporting or storing permanent-magnet motors always use the original packing materials with the warning labels attached.
- Clearly mark the storage locations with the appropriate warning labels.
- IATA regulations must be observed when transported by air.

! WARNING**Injury caused by moving or ejected parts**

Contact with moving motor parts or drive output elements and the ejection of loose motor parts (e.g. feather keys) out of the motor enclosure can result in severe injury or death.

- Remove any loose parts or secure them so that they cannot be flung out.
- Do not touch any moving parts.
- Safeguard all moving parts using the appropriate safety guards.

! WARNING**Fire due to inadequate cooling**

Inadequate cooling can cause the motor to overheat, resulting in death or severe injury as a result of smoke and fire. This can also result in increased failures and reduced service lives of motors.

- Comply with the specified cooling requirements for the motor.

! WARNING**Fire due to incorrect operation of the motor**

When incorrectly operated and in the case of a fault, the motor can overheat resulting in fire and smoke. This can result in severe injury or death. Further, excessively high temperatures destroy motor components and result in increased failures as well as shorter service lives of motors.

- Operate the motor according to the relevant specifications.
- Only operate the motors in conjunction with effective temperature monitoring.
- Immediately switch off the motor if excessively high temperatures occur.

**! CAUTION****Burn injuries caused by hot surfaces**

In operation, the motor can reach high temperatures, which can cause burns if touched.

- Mount the motor so that it is not accessible in operation.

Measures when maintenance is required:

- Allow the motor to cool down before starting any work.
- Use the appropriate personnel protection equipment, e.g. gloves.

1.1.2 Equipment damage due to electric fields or electrostatic discharge

Electrostatic sensitive devices (ESD) are individual components, integrated circuits, modules or devices that may be damaged by either electric fields or electrostatic discharge.



NOTICE

Equipment damage due to electric fields or electrostatic discharge

Electric fields or electrostatic discharge can cause malfunctions through damaged individual components, integrated circuits, modules or devices.

- Only pack, store, transport and send electronic components, modules or devices in their original packaging or in other suitable materials, e.g. conductive foam rubber or aluminum foil.
- Only touch components, modules and devices when you are grounded by one of the following methods:
 - Wearing an ESD wrist strap
 - Wearing ESD shoes or ESD grounding straps in ESD areas with conductive flooring
- Only place electronic components, modules or devices on conductive surfaces (table with ESD surface, conductive ESD foam, ESD packaging, ESD transport container).

1.1.3 Industrial security

Note

Industrial security

Siemens provides products and solutions with industrial security functions that support the secure operation of plants, systems, machines and networks.

In order to protect plants, systems, machines and networks against cyber threats, it is necessary to implement – and continuously maintain – a holistic, state-of-the-art industrial security concept. Siemens' products and solutions constitute one element of such a concept.

Customers are responsible for preventing unauthorized access to their plants, systems, machines and networks. Such systems, machines and components should only be connected to an enterprise network or the Internet if and to the extent such a connection is necessary and only when appropriate security measures (e.g. firewalls and/or network segmentation) are in place.

For additional information on industrial security measures that may be implemented, please visit:

Industrial security (<http://www.siemens.com/industrialsecurity>)

Siemens' products and solutions undergo continuous development to make them more secure. Siemens strongly recommends that product updates are applied as soon as they are available and that the latest product versions are used. Use of product versions that are no longer supported, and failure to apply the latest updates may increase customer's exposure to cyber threats.

To stay informed about product updates, subscribe to the Siemens Industrial Security RSS Feed at:

Industrial security (<http://www.siemens.com/industrialsecurity>)

Further information is provided on the Internet:

Industrial Security Configuration Manual
(<https://support.industry.siemens.com/cs/ww/en/view/108862708>)

 **WARNING**

Unsafe operating states resulting from software manipulation

Software manipulations (e.g. viruses, trojans, malware or worms) can cause unsafe operating states in your system that may lead to death, serious injury, and property damage.

- Keep the software up to date.
- Incorporate the automation and drive components into a holistic, state-of-the-art industrial security concept for the installation or machine.
- Make sure that you include all installed products into the holistic industrial security concept.
- Protect files stored on exchangeable storage media from malicious software by with suitable protection measures, e.g. virus scanners.
- Protect the drive against unauthorized changes by activating the "know-how protection" drive function.

1.1.4 Residual risks of power drive systems

When assessing the machine- or system-related risk in accordance with the respective local regulations (e.g., EC Machinery Directive), the machine manufacturer or system installer must take into account the following residual risks emanating from the control and drive components of a drive system:

1. Unintentional movements of driven machine or system components during commissioning, operation, maintenance, and repairs caused by, for example,
 - Hardware and/or software errors in the sensors, control system, actuators, and cables and connections
 - Response times of the control system and of the drive
 - Operation and/or environmental conditions outside the specification
 - Condensation/conductive contamination
 - Parameterization, programming, cabling, and installation errors
 - Use of wireless devices/mobile phones in the immediate vicinity of electronic components
 - External influences/damage
 - X-ray, ionizing radiation and cosmic radiation
2. Unusually high temperatures, including open flames, as well as emissions of light, noise, particles, gases, etc., can occur inside and outside the components under fault conditions caused by, for example:
 - Component failure
 - Software errors
 - Operation and/or environmental conditions outside the specification
 - External influences/damage
3. Hazardous shock voltages caused by, for example:
 - Component failure
 - Influence during electrostatic charging
 - Induction of voltages in moving motors
 - Operation and/or environmental conditions outside the specification
 - Condensation/conductive contamination
 - External influences/damage
4. Electrical, magnetic and electromagnetic fields generated in operation that can pose a risk to people with a pacemaker, implants or metal replacement joints, etc., if they are too close
5. Release of environmental pollutants or emissions as a result of improper operation of the system and/or failure to dispose of components safely and correctly
6. Influence of network-connected communication systems, e.g. ripple-control transmitters or data communication via the network

For more information about the residual risks of the drive system components, see the relevant sections in the technical user documentation.

Description of the motors

2.1 Use for the intended purpose

 WARNING
<p>Motors not used for the intended purpose</p> <p>If you do not use the motors correctly, there is a risk of death, severe injury and/or material damage.</p> <ul style="list-style-type: none"> • Only use the motors for their intended purpose. • Make sure that the conditions at the location of use comply with all the rating plate data. • Make sure that the conditions at the location of use comply with the conditions specified in this documentation. When necessary, take into account deviations regarding approvals or country-specific regulations.

 WARNING
<p>Malfunctions of active active implants due to magnetic and electrical fields</p> <p>Electric motors endanger people with active implants, for example heart pacemakers, who come close to the motors.</p> <ul style="list-style-type: none"> • If you are affected, stay a minimum distance of 300 mm from the motors (tripping threshold for static magnetic fields of 0.5 mT according to Directive 2013/35/EU).

If you wish to use special versions and design variants whose specifications vary from the motors described in this document, then contact your local Siemens office.

If you have any questions regarding the intended usage, please contact your local Siemens office.

The 1FK2 motor is intended for industrial or commercial plants.

The motor is designed for operation in sheltered areas under normal climatic conditions, such as those found on shop floors.

For more detailed information, refer to Chapter "Environmental conditions (Page 25)".

The 1FK2 motor is certified only for operation through a converter.

Any other use of the motor is considered to be incorrect use.

Compliance with all specifications in the operating instructions is part of correct usage.

Observe the details on the rating plate.

2.2 Technical features and environmental conditions

2.2.1 Directives and standards

Standards that are complied with

The motors of the type series SIMOTICS S, SIMOTICS M, SIMOTICS L, SIMOTICS T, SIMOTICS A, called "SIMOTICS motor series" below, fulfill the requirements of the following directives and standards:

- EN 60034-1 - Rotating electrical machines – Dimensioning and operating behavior
- EN 60204-1 - Safety of machinery – Electrical equipment of machines; general requirements

Where applicable, the SIMOTICS motor series are in conformance with the following parts of EN 60034:

Feature	Standard
Degree of protection	EN 60034-5
Cooling ¹⁾	EN 60034-6
Type of construction	EN 60034-7
Connection designations	EN 60034-8
Noise levels ¹⁾	EN 60034-9
Temperature monitoring	EN 60034-11
Vibration severity grades ¹⁾	EN 60034-14

¹⁾ Standard component, e.g. cannot be applied to built-in motors

Relevant directives

The following directives are relevant for SIMOTICS motors.

European Low-Voltage Directive

SIMOTICS motors comply with the Low-Voltage Directive 2014/35/EU.

European Machinery Directive

SIMOTICS motors do not fall within the scope covered by the Machinery Directive.

However, the use of the products in a typical machine application has been fully assessed for compliance with the main regulations in this directive concerning health and safety.

European EMC Directive

SIMOTICS motors do not fall within the scope covered by the EMC Directive. The products are not considered as devices in the sense of the directive. Installed and operated with a converter, the motor - together with the Power Drive System - must comply with the requirements laid down in the applicable EMC Directive.



European RoHS Directive

The SIMOTICS motor series complies with the Directive 2011/65/EU regarding limiting the use of certain hazardous substances.

European Directive on Waste Electrical and Electronic Equipment (WEEE)

The SIMOTICS motor series complies with the 2012/19/EU directive on taking back and recycling waste electrical and electronic equipment.

Eurasian conformity

SIMOTICS motors comply with the requirements of the Russia/Belarus/Kazakhstan (EAC) customs union.

**China Compulsory Certification**

SIMOTICS motors do not fall within the scope covered by the China Compulsory Certification (CCC).

CCC negative certification:

CCC product certification

<https://support.industry.siemens.com/cs/products?search=CCC&ctp=Certificate&mf=ps&=DefaultRankingDesc&pnid=13347&lc>

**Underwriters Laboratories**

SIMOTICS motors are generally in compliance with UL and cUL as components of motor applications, and are appropriately listed.

Specifically developed motors and functions are the exceptions in this case. Here, it is important that you carefully observe the contents of the quotation and that there is a cUL mark on the rating plate!

**Quality systems**

Siemens AG employs a quality management system that meets the requirements of ISO 9001 and ISO 14001.

Certificates for SIMOTICS motors can be downloaded from the Internet at the following link:

Certificates for SIMOTICS motors

<https://support.industry.siemens.com/cs/ww/de/ps/13347/cert>

2.2.2 General technical features

Property	Version
Type of motor	Permanent-magnet synchronous motor
Degree of protection according to EN 60034-5 (IEC 60034-5)	IP64, optionally IP65
Cooling acc. to EN 60034-6	Natural cooling (IC410)
Type of construction according to EN 60034-7 (IEC 60034-7)	IM B5 (IM V1, IM V3)
Shaft extension according to DIN 748-3 (IEC 60072-1)	Plain shaft, optionally with feather key (balanced with half feather key)
Shaft and flange accuracy acc. to DIN 42955 (IEC 60072-1)	Tolerance N (normal), for radial eccentricity of the shaft extension, concentricity of centering edge, and axial eccentricity of the mounting flange to the axis of the shaft extension
Vibration severity grade according to EN 60034-14 (IEC 60034-14)	Grade A is maintained up to rated speed
Insulation of the stator winding according to EN 60034-1 (IEC 60034-1)	1FK2□03: Temperature class 130 (B) for a winding temperature of $\Delta T = 80$ K at an ambient temperature of +40 °C 1FK2□04 ... 1FK2□10: Temperature class 155 (F) for a winding temperature of $\Delta T = 100$ K at an ambient temperature of +40 °C
Sound pressure level L_{pA} (1 m) according to DIN EN ISO 1680, max. tolerance + 3 dB(A)	1FK2□03, 1FK2□04: 55 dB (A); 1FK2□05, 1FK2□06: 65 dB (A); 1FK2□08, 1FK2□10: 70 dB (A)
Encoder systems, built-in with DRIVE-CLiQ interface	<ul style="list-style-type: none"> AS22DQC absolute encoder, singleturn, 22-bit AM22DQC absolute encoder 22-bit + 12-bit multiturn
Holding brake	optionally installed, 24 V DC
Connection	Connectors for power and signals, rotatable
Paint finish	RAL7016 (anthracite)

2.2.3 Environmental conditions

You can classify the environmental conditions for stationary use at weather-protected locations according to the standard DIN EN 60721-3-3.

With the exception of environmental influences "Low air temperature", "Low air pressure", and "Condensation", the motor complies with climate class 3K4.

Table 2- 1 Permissible environmental conditions for the motor based on climate class 3K4

Environmental parameter		Unit	Value
a)	Low air temperature	°C	- 15
b)	High air temperature	°C	+ 40
c)	Low relative humidity	%	5
d)	High relative humidity	%	95
e)	Low absolute humidity	g/m ³	1
f)	High absolute humidity	g/m ³	29
g)	Rate of temperature change ¹⁾	°C/min	0.5
h)	Low air pressure ⁴⁾	kPa	89
i)	High air pressure ²⁾	kPa	106
j)	Solar radiation	W/m ²	700
k)	Thermal radiation	-	-
l)	Air movement ³⁾	m/s	1.0
m)	Condensation	-	Not permissible
n)	Wind-driven precipitation (rain, snow, hail, etc.)	-	-
o)	Water (other than rain)	-	See protection class
p)	Formation of ice	-	-

¹⁾ Averaged over a period of 5 min

²⁾ Conditions in mines are not considered.

³⁾ A cooling system based on natural convection can be disturbed by unforeseen air movements.

⁴⁾ The limit value of 89 kPa covers applications at altitudes up to 1000 m.

Note

Installation instructions

The motor is not suitable for operation

- In salt-laden or aggressive atmospheres
- Outdoors
- In a vacuum
- In hazardous areas with a danger of explosion

You will find additional data on the environmental conditions, such as for transport and storage of the motor, in Chapter "Transportation and storage (Page 38)".

2.2.4 Degree of protection

1FK2 motors can be designed with degree of protection IP64 or IP65.

The degree of protection is stated on the rating plate.

The motors with IP65 degree of protection have a radial shaft seal.

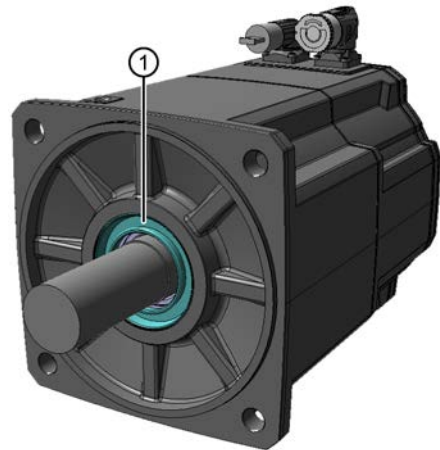
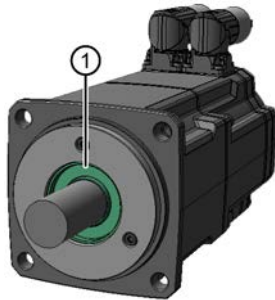

1FK2□03 ... 1FK2□04

1FK2□05 ... 1FK2□10

① Shaft sealing ring

The radial shaft seal ring shortens the useful shaft extension on the 1FK2□03 and 1FK2□04.

Note

It is permissible that the radial shaft sealing ring runs dry.

With degree of protection IP65, it is not permissible for liquid to collect in the flange.

The service life of the radial shaft sealing ring is approximately 25000 operating hours.

You will find further information in Chapter

 "Shaft extension (Page 31)"

2.2.5 Noise emission

When operated in the speed range 0 to rated speed, 1FK2 motors can reach the following measuring surface sound pressure level L_p :

Table 2- 2 Sound pressure level

Cooling method	Size	Measuring surface sound pressure level L_p
Naturally cooled	1FK2□03 1FK2□04	55 dB(A) + 3 dB tolerance
	1FK2□05 1FK2□06	65 dB(A) + 3 dB tolerance
	1FK2□08 1FK2□10	70 dB(A) + 3 dB tolerance

The motors are certified for a wide range of installation and operating conditions. These conditions such as rigid or vibration-isolated foundation design influence noise emission, sometimes significantly.

2.3 Structure of the article number

The article number describes the motor with the following structure.

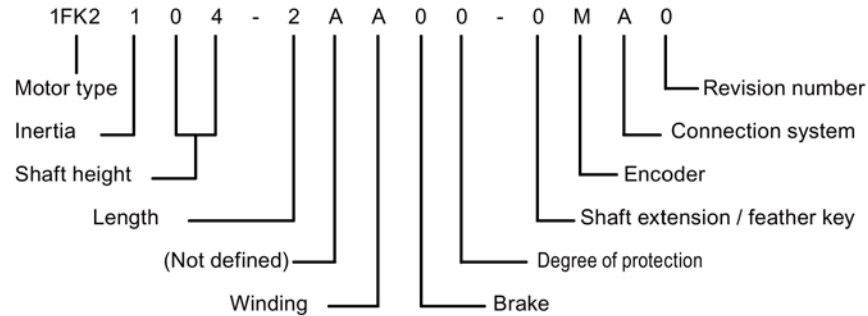

You can find possible combinations in the relevant catalog.
Please note that not every theoretical combination is possible.

Description	Position of the article number																		
	1	2	3	4	5	6	7	-	8	9	10	11	12	-	13	14	15	16	
SIMOTICS S-1FK2 synchronous servomotors	1	F	K	2															
Version	High Dynamic				1														
	Compact				2														
	High Inertia				3														
Frame size / shaft height	SH 30				0	3													
	SH 40				0	4													
	SH 48 CT SH 52 HD				0	5													
	SH 63				0	6													
	SH 80				0	8													
	SH 100				1	0													
	Overall length	0 ... 8							-	<input type="checkbox"/>									
(Not defined)										A									
Test voltage (line voltage for the converter)	max. 240 V 1 AC																		
	3000 rpm @ 230 V										G								
	max. 480 V 3 AC																		
	1500 rpm @ 400 V										B								
	2000 rpm @ 400 V					1000 rpm @ 230 V					C								
	3000 rpm @ 400 V					1500 rpm @ 230 V					F								
	6000 rpm @ 400 V					3000 rpm @ 230 V					K								
Holding brake	None											0							
	with											1							
Protection class	IP64											0							
	IP65 with radial shaft seal ring, without spring											1							
Shaft geometry	Plain shaft (without keyway)														0				
	Shaft with feather key														1				

Description of the motors

2.3 Structure of the article number

Description	Position of the article number																		
	1	2	3	4	5	6	7	-	8	9	10	11	12	-	13	14	15	16	
	Plain shaft, alternative shaft extension (11 mm x 23 mm), for 1FK2□03 only					0	3						0		2				
Encoder	Absolute encoder, singleturn, 22-bit (encoder AS22DQC)														S				
	Absolute encoder, multiturn, 22-bit + 12-bit (encoder AM22DQC),														M				
Connection type	2CC (two-wire technology) for S 120														B				
Revision number	Start																	0	

1) More detailed information is provided in the relevant catalog.

2.4 Rating plate data

The rating plate contains the article number and the technical data of the motor.

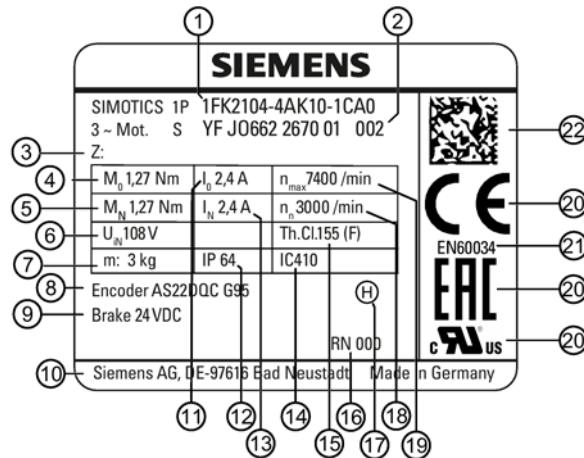

Figure 2-1 Rating plate

Position	Description / technical specifications	Position	Description / technical specifications
1	Article number	12	Degree of protection
2	ID No., serial number	13	Rated current I_{rated} / A
3	Additional options specified as a supplement to the article number	14	Cooling mode according to EN 60034-6
4	Static torque M_0 / Nm	15	Thermal class of the insulation system
5	Rated torque M_{rated} / Nm	16	Revision
6	Induced voltage at rated speed V_N / V	17	Type of balancing (only for motors with feather key)
7	Motor weight m / kg	18	Rated speed n_{rated} / rpm
8	Marking of encoder type	19	Maximum speed n_{max} / rpm
9	Data of the holding brake	20	Certifications
10	Manufacturer's address	21	Standard for all rotating electrical machines
11	Stall current I_0 / A	22	Data matrix code

Mounting and options

3.1 Safety symbols on the motor

The following warnings and notices are attached to the motor.

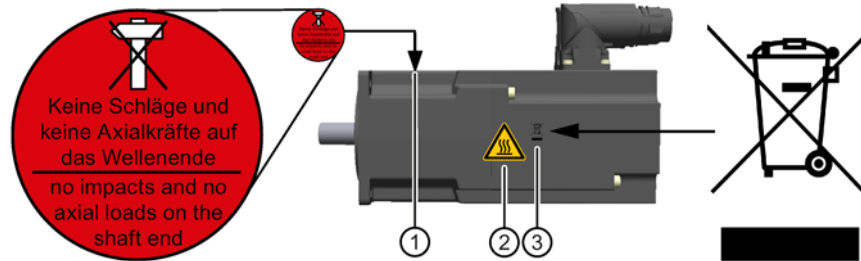

- 1 Notice "No impacts and no axial loads on the shaft end"
- 2 Warning symbol "Warning against hot surface"
- 3 WEEE mark
Dispose of the motor in accordance with WEEE Directive 2012/19/EU.

3.2 Shaft extension

The motors are supplied with cylindrical shaft extensions. The shaft extension usually has a centering thread according to DIN 332, form DR.

Optionally, a shaft extension with a keyway and feather key can be supplied.

For the 1FK2□03 and 1FK2□04 with degree of protection IP65, the radial shaft seal ring shortens the useful shaft extension.

Size	Shaft dimensions Diameter × length in mm	Shaft dimensions with IP65 Diameter × length in mm	Feather key Width × height × length in mm	Centering thread DIN 332-DR
1FK2□03	14 × 30	14 × 21.5	5 × 5 × 16	M5
	11 × 23 ¹⁾	-	-	M4
1FK2□04	19 × 40	19 × 32	6 × 6 × 22	M6
1FK2□05	19 × 40		6 × 6 × 32	M6
1FK2□06	24 × 50		8 × 7 × 40	M8
1FK2□08	32 × 58		10 × 8 × 45	M12
1FK2□10	38 × 80		10 × 8 × 70	M12

¹⁾ The shaft extension 11 mm × 23 mm can only be supplied without a keyway and without a shaft sealing ring (IP65).

3.3 Bearing version

The 1FK2 motors have deep-groove ball bearings with life grease lubrication

3.4 Permissible radial and axial forces

NOTICE

Damage to the motor due to axial forces on the shaft extension

Axial forces on the shaft extension can damage motors with an integrated holding brake.

- Avoid impermissible forces on the shaft extension.

The following axial and radial forces are permitted.

Motor	Radial forces with reference type in N	Dynamic axial forces in N	Static axial forces in N
1FK2□03	280	40	75
1FK2□04	400	60	100
1FK2105	800	75	120
1FK2106	1150	125	200
1FK2205	700	75	120
1FK2□06	900	125	200
1FK2□08	1600	250	300
1FK2210	2200	400	450

3.5 Thermal motor protection

To protect the motor from overheating, a thermal motor type is implemented in the SINAMICS S120 converter.

If the motor is operated within the permissible ambient temperature range and the ambient temperature is correctly set in the converter, the converter protects the motor from overheating.

Before the motor reaches the maximum temperature, the converter outputs the warning "Motor overtemperature".

If the motor exceeds the maximum temperature, the converter switches off the motor with the error message "Motor overtemperature".

You must set the ambient temperature on the converter for the thermal motor type.

For ambient temperatures > 40 °C, you must adapt the ambient temperature in the thermal motor type.

You will find precise information on this in the converter manual.

3.6 Encoder

Motors with DRIVE-CLiQ interface are designed to operate with the SINAMICS converter system.

Signal transmission to the converter is performed digitally.

The motors have an electronic rating plate that simplifies commissioning and diagnostics.

The motor and encoder system are automatically identified and all motor parameters are automatically set.

You will find further information in the relevant SINAMICS manual.

NOTICE
Damage to electrostatic sensitive devices
The contacts of the DRIVE-CLiQ interface have direct contact with components that can be destroyed by electrostatic discharge (ESDS).
<ul style="list-style-type: none"> • Avoid touching the terminals directly with hands or tools. They may be electrostatically charged and damage components.

The encoders are suitable for the extended safety functions.

Table 3- 1 The 1FK2 can be supplied with the following encoders:

	Absolute encoder, singleturn, 22 bit	Absolute encoder 22 bit +12 bit multiturn
Encoder designation	AS22DQ	AM22DQ
Description	Absolute encoder 22-bit single-turn	Absolute encoder 22-bit + 12-bit multiturn
Identifier at the 14th digit of the article number	S	M
Operating voltage	24 V	24 V
Maximum current consumption	70 mA	70 mA
Resolution	4,194,304 = 22 bit	4,194,304 = 22 bit
Absolute position	Yes, one revolution	Yes, 4096 revolutions (12 bits)
Angular error	± 100 "	± 100 "

3.7 Cooling

The motor is naturally cooled. The power loss is dissipated through thermal conduction, thermal radiation and natural convection.

Note the specifications on thermally non-insulated mounting and on thermally insulated mounting.

You will find information on this in the relevant configuration manual.

3.8 Holding brake

The type of holding brake installed depends on the size of the motor.

Type of the holding brake	Spring-loaded brake	Permanent-magnet brake
installed in the motors	1FK2□03 ... 1FK2□04	1FK2□05 ... 1FK2□10
Method of operation	<p>The spring exerts a tensile force on the brake armature disk. This means that in the no-current condition, the brake is closed and the motor shaft is held.</p> <p>When 24 V DC rated voltage is applied to the brake, the current-carrying coil produces an opposing field. This neutralizes the force of the spring and the brake opens without any residual torque.</p> <p>The spring-loaded brake has a torsional backlash less than 1°.</p>	<p>The magnetic field of the permanent magnets exerts a pulling force on the brake armature disk. This means that in the no-current condition, the brake is closed and the motor shaft is held.</p> <p>When 24 V DC rated voltage is applied to the brake, the current-carrying coil produces an opposing field. This neutralizes the force of the permanent magnets and the brake opens without any residual torque.</p> <p>The permanent magnet brake has a torsionally stiff connection to the motor rotor.</p>

NOTICE

Damage to the motor due to axial forces on the shaft extension

Axial forces on the shaft extension can damage motors with an integrated holding brake.

- Avoid impermissible forces on the shaft extension. You will find detailed information in Chapter:
 -  Permissible radial and axial forces (Page 32)

- The holding brake is used to clamp the motor shaft when the motor is at a standstill. The holding brake is **not** a working brake for braking the rotating motor.
- A limited number of Emergency Stop operations is permissible.

 **WARNING**

Danger to life caused by unintended movements of the machine or installation

If the number of permissible braking operations is exceeded, the holding brake wears and no longer works properly. The resulting inadvertent motion of your machine or system can cause death or severe injury.

- Observe the permissible number of braking operations.
- Operate the motor only in conjunction with an intact brake.

- Do not exceed the maximum operating energy per emergency braking.

NOTICE**Premature wear of the motor holding brake when operated outside its permissible voltage range**

Operating the motor holding brake outside its permissible voltage range at the motor connection will damage the brake.

- Ensure that the motor holding brake is only operated within its permissible voltage range.

- The rated voltage of the holding brake is 24 V DC +/- 10 %. Voltages outside this tolerance range can cause disturbances.

NOTICE**Faulty brake function due to inadmissible wear**

Inadmissible wear means that the braking function can no longer be guaranteed.

- Comply with the Emergency Stop characteristics stated above.
- Avoid repeated brief acceleration of the motor against a holding brake that is still closed. Consider the operating times of the brakes and the relays in the drive control and enable.

Note

Subsequent conversion of motors with or without a holding brake is not possible.

The technical data for the holding brake is contained in the Configuration Manual of the motor.





Preparing for use

4.1 Shipping and packaging

The drive systems are put together on an individual basis.

Please pay attention to the handling notes on the packaging in which the motor is delivered.

Table 4- 1 Handling notes and their meaning

Symbol	Meaning	Symbol	Meaning
	Fragile (ISO 7000, No. 0621)		Keep dry (ISO 7000, No. 0626)
	Top (ISO 7000, No. 0623)		Do not stack (ISO 7000, No. 2402)

Checking the delivery for completeness

- Upon receipt of the delivery, check immediately whether the items delivered match the accompanying documents.

Note

Siemens will not accept any claims for missing or incorrect items submitted at a later date.

- Report any visible transportation damage to the delivery company immediately.
- Report any visible defects or missing items to the competent Siemens office immediately.

The items supplied include a second rating plate. The second rating plate can be used to post the motor data additionally in the vicinity of the motor.

The additional rating plate is in the material safety data sheet.

The inserts with the safety instructions are part of the scope of delivery.

Note

Keep the sheets with the safety instructions in an accessible location at all times.

4.2 Transportation and storage

4.2.1 Transport

Note

Comply with the local national regulations for the transportation of motors.

- Use suitable load suspension devices when transporting and installing the motor.
- Do not lift the motor by the connector.
- Transport the motor carefully.

Lifting and transporting with lifting slings

You can lift and transport the motor using lifting slings.

 WARNING
Incorrectly dimensioned or incorrectly used lifting slings
If lifting slings are incorrectly dimensioned or incorrectly used, the motor can fall and cause death, severe injury and/or damage to property.
<ul style="list-style-type: none">• Only use lifting slings that are suitable for the weight of the motor.• Attach the lifting slings as shown in the figure "Lifting and transporting with lifting slings".

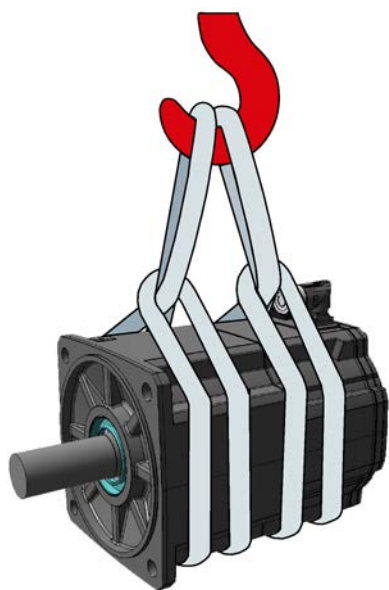

Figure 4-1 Lifting and transporting with lifting slings (example diagram)

Lifting and transporting the motor with eyebolts

For the 1FK2□10 motors, you can use eyebolts and a lifting beam for lifting and transporting.

! WARNING

Incorrect or unused lifting points

Due to incorrect or unused lifting points, the motor can fall and cause death, severe injury and/or damage to property.

- Only lift and transport larger motors using the eyebolts screwed on to the end shields.
- Completely screw in the eyebolts and tighten by hand (approx. 8 Nm).
- Do not use bent or damaged eyebolts.
- Only use eyebolts with laminated fiber washers.
- Loads applied transversely to the plane of the eyebolts are not permitted.

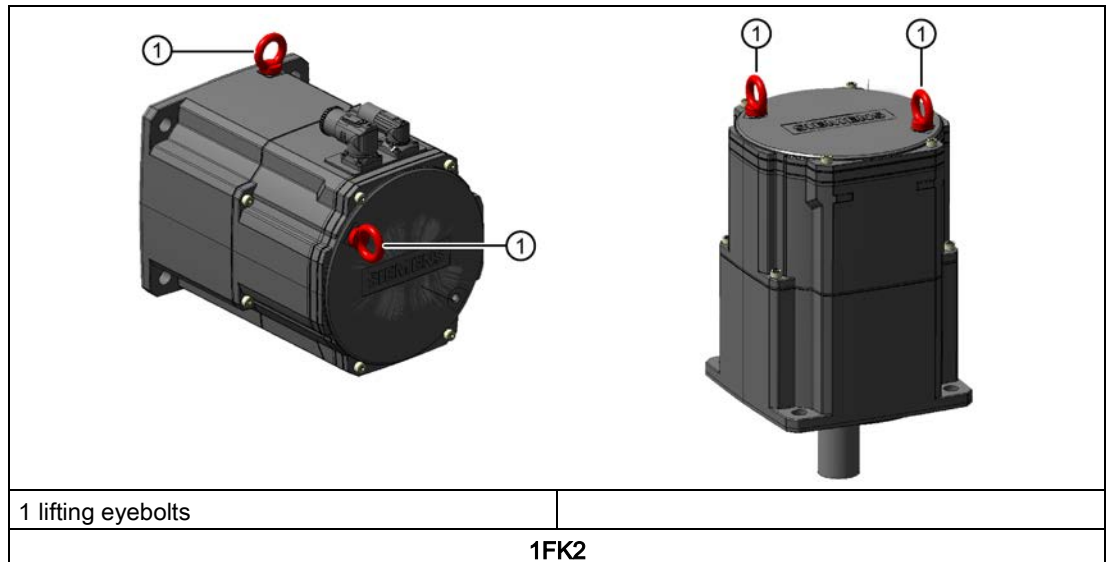

Procedure

1. Screw the lifting eyes (eyebolts) in at appropriate locations for the orientation of the motor during transportation.
2. Hook the beam into the lifting eyes (eyebolts).

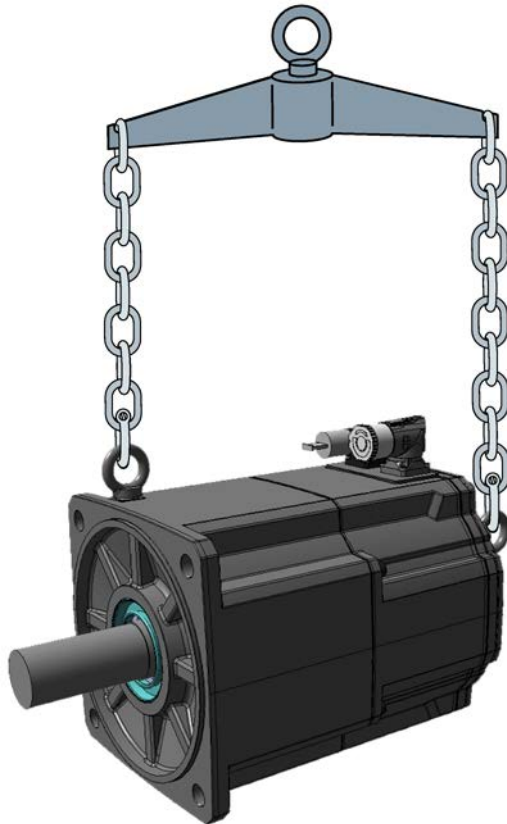

Figure 4-2 Transporting the motor with a beam (example)

3. Set the motor down on a hard, level surface.

<p>! WARNING</p> <p>Danger of severe injury due to unintentional movements of the motor</p> <p>If the motor is not secured after being set down, unintentional movements of the motor can cause serious injury.</p> <ul style="list-style-type: none">• After the motor has been set down, secure it in position.• Do not release the lifting devices until the motor has been secured in position.
--

4. Secure the motor against unintentional movements.

4.2.2 Storage

Note

If possible, store the motor in its original packaging.

Preserve the free shaft extensions, sealing elements, and flange surfaces with a protective coating.

NOTICE

Seizure damage to bearings

If the motors are stored incorrectly, bearing seizure damage can occur, e.g. brinelling, as a result of vibration.
--

- | |
|---|
| <ul style="list-style-type: none">• Comply with the storage conditions. |
|---|

Storage conditions

Please observe the warning instructions on the packaging and labels.

Store the motor in a dry, dust-free, and vibration-free indoor storage facility.

Adhere to the following values:

- $v_{rms} < 0.2 \text{ mm/s}$
- Max. temperatures: -15° C to 55° C
- Mean relative humidity $< 75\%$

Long-term storage

Note

Storage time up to two years

The storage time affects the properties of the roller bearing grease.

- Store the motor for up to two years at -15° C to 55° C.
-

If you intend to place the motor in storage for longer than six months, you must ensure that the storage area satisfies the following conditions.

Table 4- 2 **Environmental conditions for long-term storage in the product packaging according to Class 1K3 to EN 60721-3-1 - with the exception of influencing environmental variables "Air temperature", "Highest relative humidity" and "Condensation"**

Climatic ambient conditions	- 15 °C ... + 55 °C
Highest relative humidity	< 60 %, condensation not permissible
Mechanical ambient conditions	vibration-free storage room $v_{rms} < 0.2$ mm/s
Protection against chemical substances	Protected in acc. with Class 1C2
Biological ambient conditions	Suitable in acc. with Class 1B2
Duration	<ul style="list-style-type: none">• Six months for the conditions listed above.• Special preservation measures are required for storage times of 6 months up to maximum of two years.

Check the correct state of the motor every six months.

- Check the motor for any damage.
- Perform any necessary maintenance work.
- Check the state of the dehydrating agent and replace when necessary.
- Record the preservation work so that all preservation coating can be removed prior to the commissioning.

Condensation

The following ambient conditions encourage the formation of condensation:

- Large fluctuations of the ambient temperature
- Direct sunshine
- High air humidity during storage.

Avoid these ambient conditions.

Use a dehydrating agent in the packaging.

5.1 Safety instructions

 WARNING
Danger of the motor down due to incorrect transport and/or lifting Due to incorrect transport and/or lifting, the motor can fall and cause death, severe injury and/or damage to property. <ul style="list-style-type: none">• Lifting devices, ground conveyors, and load suspension equipment must comply with requirements.• The maximum capacity of the lifting equipment and the load suspension device must correspond to the weight of the motor (see the rating plate).• Do not attach any additional loads to the lifting equipment.• To hoist the motor, use suitable cable-guidance or spreading equipment, particularly if the motor is equipped with built-on assemblies.• The motor must not be lifted or transported by means of the power connector or signal connector.• Do not stand in the slewing range of hoisting gear or under suspended loads.

 WARNING
Danger to life from permanent magnet fields Even when switched off, electric motors with permanent magnets pose a potential risk for persons with heart pacemakers or implants if they are close to inverters/motors. <ul style="list-style-type: none">• If you have a heart pacemaker or implant, keep a minimum distance of 20 cm.• When transporting or storing permanent magnet motors always use the original packing materials with the warning labels attached.• Clearly mark the storage locations with the appropriate warning labels.• IATA regulations must be observed when transporting by air.

 WARNING
Danger to life due to freely rotating parts Contact with rotating parts can cause death or severe injury. <ul style="list-style-type: none">• Do not touch any rotating parts.• Mount a cover cap or protective shroud over freely rotating parts.

 WARNING
Danger to life due to unpredictable movements of the system The system can perform unpredictable movements under load that can cause death or severe injury. <ul style="list-style-type: none">• De-energize the system before starting work.• Disconnect all loads from the system.• Secure the system against accidental reclosure.

NOTICE
Damage to shaft sealing rings caused by solvent If shaft sealing rings come into contact with solvents when preservation coating is removed, the shaft sealing rings can be damaged. <ul style="list-style-type: none">• Avoid contact between solvents and shaft sealing rings.

NOTICE
Thermal damage to temperature-sensitive parts Some parts of the electrical motor enclosure can reach temperatures that exceed 100 °C. If temperature-sensitive parts, for instance electric cables or electronic components, come into contact with hot surfaces then these parts can be damaged. <ul style="list-style-type: none">• Ensure that no temperature-sensitive parts come into contact with hot surfaces.

5.2 Checklists prior to mounting

Note

Required checks

The checklists below do not purport to be complete. It may be necessary to perform additional checks and tests in accordance with the situation specific to the particular installation site.

Assemble the motor as described in the following chapters of the operating instructions.

Thoroughly familiarize yourself with the safety instructions and observe the checklists below before starting any work.

Table 5- 1 Checklist (1) - general checks

Check	OK
Are all of the necessary components of the configured drive line-up available, correctly dimensioned, installed and connected?	
Are the environmental conditions in the permissible range?	

Table 5- 2 Checklist (2) - checks regarding the mechanical system

Check	OK
Is the motor free of visible damage?	
Have the mounting surfaces (e.g. flange, shaft) on the customer machine and on the motor been cleaned?	
Are the mounting surfaces free of corrosion?	
Do the mounting dimensions (e.g. shaft diameter, shaft length, true run) on the customer machine meet the specification?	

5.3 Mounting instructions

NOTICE

Damage to the motor due to runout on the shaft extension

Runout and thrust on the shaft extension of the motor can damage the motor.

- Mount the motor without runout and thrust on the shaft extension.

Note

Note the technical data on the rating plate on the motor frame.

- Comply with the data on the rating plate, warnings, and notices on the motor.
- Check the permissible ambient conditions (e.g. temperatures, installation altitude) at the installation location.
Their use is prohibited in hazardous zones.
- Thoroughly clean the shaft extension of corrosion protection. Use commercially available solvents.
- Ensure sufficient dissipation of heat. See Chapter "Cooling (Page 33)"
- If the motor is installed vertically with the end of the shaft facing up, ensure that no liquid can enter the upper bearing.
- Ensure that the flange is in even contact with the mounting surface.
- Use the hexagon socket-head screws, property class at least 8.8.
- When tightening the fastening bolts avoid any uneven stressing.
- Observe the tightening torques of the fastening bolts of the motor flange. See table "Tightening torques for fastening bolts")

Tightening torques for fastening bolts

The general tolerance for the tightening torque is 10%. The tightening torque is based on a friction coefficient of $\mu = 0.14$.

Motor	Bolt DIN 7984	Washer ISO 7092 [mm]	Tightening torque for bolts (not for electrical connections)
1FK2□03	M5	5 (d2 = 9)	4 Nm
1FK2□04	M6	6 (d2 = 11)	8 Nm
1FK2□05	M8	8 (d2 = 15)	20 Nm
1FK2□06	M8	8 (d2 = 15)	20 Nm
1FK2□08	M10	10 (d2 = 18)	35 Nm
1FK2□10	M12	12 (d2 = 20)	60 Nm

Tightening torques for fastening bolts

5.4 Mounting the drive elements

Overview

NOTICE

Damage to the motor due to runout on the shaft extension

Runout and thrust on the shaft extension of the motor can damage the motor.

- Mount the motor without knocking it or exerting force on the shaft extension.

Description of functions

Assemble the input and output elements in such a way as to minimize the stress on shafts and bearings from transverse forces.

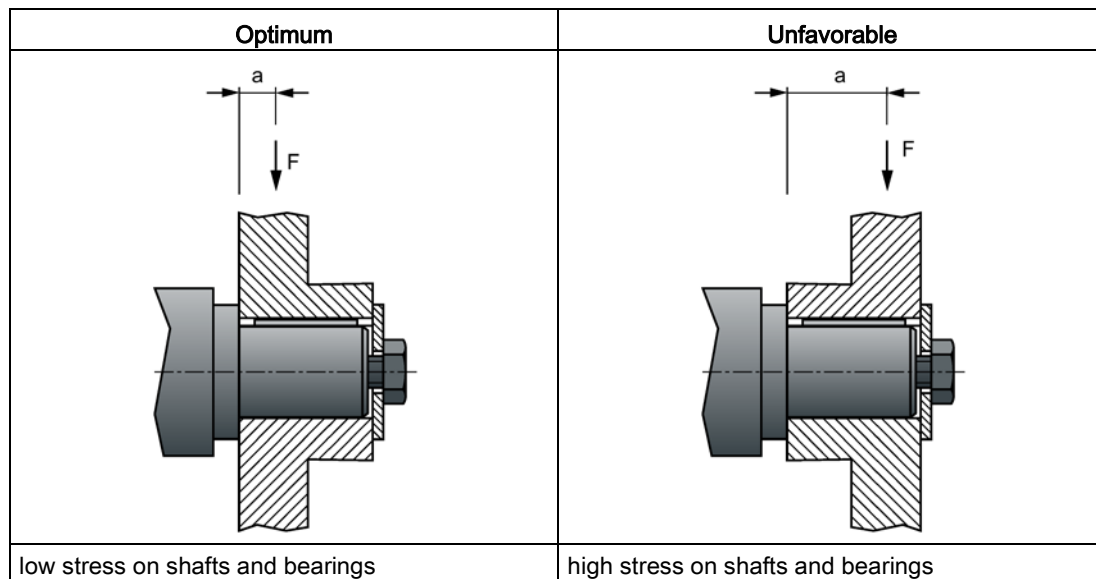

Mount or remove the power output elements (e.g. couplings, gear wheels, belt pulleys) using suitable devices only (see figure).

- Use the threaded hole in the shaft extension.
- If required, heat up the output elements before mounting or removing.

- When removing the output elements, use an intermediate disk to protect the centering in the shaft extension.
- If necessary, completely balance the motor together with the output elements according to ISO 1940.

Note

Motors with feather key are half-key balanced. The motors have been balanced with half a feather key.

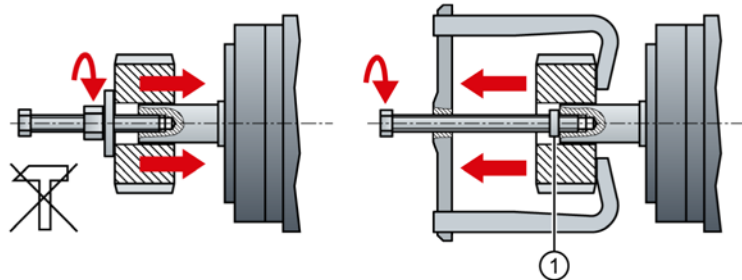

1 Intermediate washer/disk (to protect the centering in the shaft extension)

Figure 5-1 Mounting and removing output elements

You will find the dimensions of the motor in Chapter:

 "Dimension drawings (Page 91)" or in the relevant catalog

5.5 Vibration response

Vibration severity grade

Motors with a keyway are balanced with a half fitted key by the manufacturer.

The vibration response of the system at the location of use is influenced by output elements, any built-on parts, the alignment, the installation, and external vibrations. This can change the vibration values of the motor.

The motors conform to vibration severity grade A according to EN 60034-14 (IEC 60034-14).

The specified values refer only to the motor. The conditions at the installation location can influence the system vibration response and increase the vibration values on the motor.

The vibration severity grade is maintained up to the rated speed (n_N).

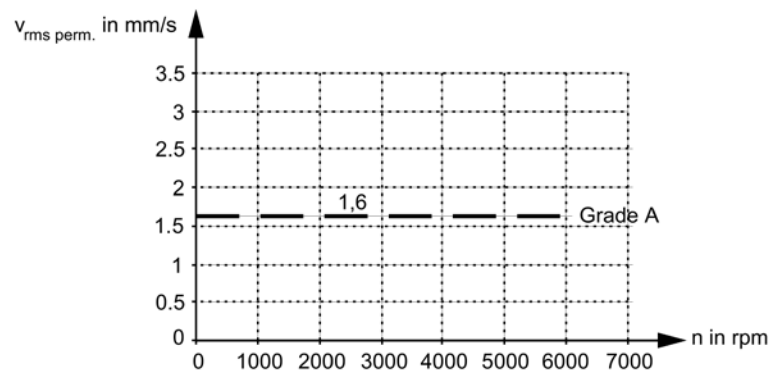

Figure 5-2 Vibration severity grades

Vibration response

Comply with the vibration values in the following table to ensure perfect functioning of the motor and a long service life.

Table 5- 3 Vibration values

Vibration velocity V_{rms} to ISO 10816	max. 4.5 mm/s
Vibration acceleration a_{peak} axial	50 m/s ²
Vibration acceleration a_{peak} radial	50 m/s ²

To evaluate the vibration velocity, the measuring equipment must meet the requirements of ISO 2954.

Select the measuring locations according to ISO 10816-1, Section 3.2.

The vibration acceleration is evaluated in the frequency range from 10 Hz to 2000 Hz. The maximum peak in the measurement time range is considered.

The vibration values must not exceed the specified limits at any measuring location.

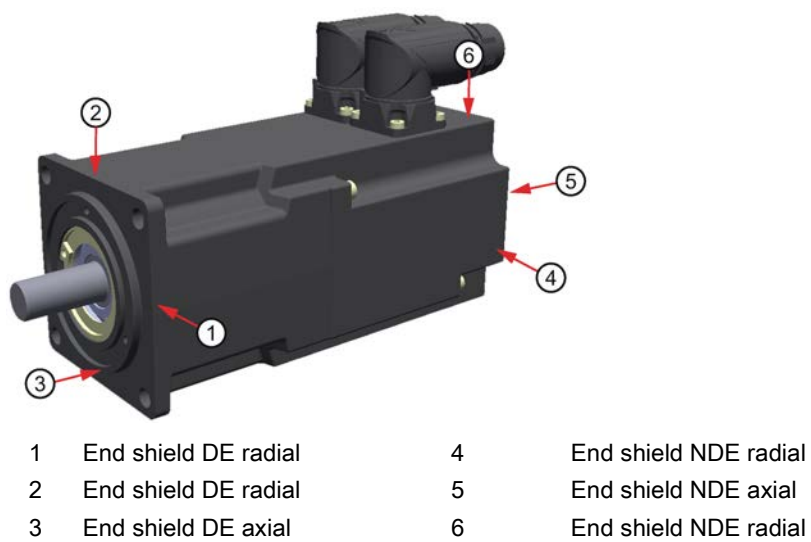

Figure 5-3 Measuring points for vibration values

Connecting

6.1 Safety instructions



! WARNING
<p>Electric shock and danger to life due to other energy sources</p> <p>Touching live components can result in death or severe injury.</p> <ul style="list-style-type: none"> • Only work on electrical devices when you are qualified for this job. • Always observe the country-specific safety rules. <p>Generally, the following six steps apply when establishing safety:</p> <ol style="list-style-type: none"> 1. Prepare for disconnection. Notify all those who will be affected by the procedure. 2. Isolate the drive system from the power supply and take measures to prevent it being switched back on again. 3. Wait until the discharge time specified on the warning labels has elapsed. 4. Check that there is no voltage between any of the power connections, and between any of the power connections and the protective conductor connection. 5. Check whether the existing auxiliary supply circuits are de-energized. 6. Ensure that the motors cannot move. 7. Identify all other dangerous energy sources, e.g. compressed air, hydraulic systems, or water. Switch the energy sources to a safe state. 8. Check that the correct drive system is completely locked. <p>After you have completed the work, restore the operational readiness in the inverse sequence.</p>

! WARNING
<p>Electric shock when connected to inadequately grounded line supplies</p> <p>Connecting a motor to an inadequately grounded line supply can result in death, severe injury and damage to the motor if a fault occurs.</p> <ul style="list-style-type: none"> • Connect motors, as part of the drive system, to TN and TT line supplies with a grounded neutral point or to IT line supplies. • Ensure that the SINAMICS devices and motors are compatible with the residual current device according to EN 61800-5-1 before you connect the devices and motors to the line supply using residual current devices (RCDs). • For line supplies with grounded line conductor, e.g. TT line supplies, use an isolating transformer with grounded neutral point (on the secondary side) between the line supply and the drive system, so that the motor insulation is not overstressed. • When connected to IT line supplies, a monitoring device must signal the first fault between an active part and ground. Eliminate this fault immediately.

6.2 Permissible line system types

In combination with the drive system, the motors are generally approved for operation on TN and TT systems with **grounded neutral** and on IT systems.

In operation on IT systems, the occurrence of a first fault between an active part and ground must be signaled by a monitoring device. According to IEC 60364-4-41, it is recommended that the first fault is removed as quickly as is practically possible.

In systems with a **grounded external conductor**, an isolating transformer with grounded neutral (secondary side) must be connected between the line supply and the drive system to protect the motor insulation from excessive stress. The majority of TT systems have a grounded external conductor, so in this case an isolating transformer must be used.

6.3 System integration

6.3.1 Connection notes

6.3.1.1 Motor connection

Overview

NOTICE
Destruction of the motor if it is directly connected to the three-phase line supply
The motor will be destroyed if it is directly connected to the three-phase line supply.
<ul style="list-style-type: none"> • Only operate the motors with the appropriately configured converters.

NOTICE
Damage to electronic components as a result of electrostatic discharge
Electrostatically sensitive devices (ESD) can be damaged or destroyed by electrostatic discharge.
<ul style="list-style-type: none"> • Observe the ESD protection measures. • Only grounded personnel with grounded tools may touch the component connections. • Heed the EMC information provided by the manufacturer of the converter.

- The manufacturer of the plant/machine is responsible for the ensuring that the installation is performed correctly.
- Observe the data on the rating plate and the circuit diagrams.
- Adapt the connecting cables to the type of use and the voltages and currents that occur.

- Use prefabricated cables from SIEMENS (not in the scope of delivery). These cables reduce installation costs and increase operational reliability (see the Product Information).
- Make sure that the inside of the connector is clean and free of cable cuttings and moisture.
- Check that the degree of protection is complied with at the seals and sealing surfaces of the connectors.
- Secure connecting cables against torsion, tensile and compressive strain, and protect them against kinking. It is not permissible to subject the connector to continuous force.

Current-carrying capacity for power and signal cables

The current-carrying capacity of PVC/PUR-insulated copper cables is specified for routing types B1, B2 and C under continuous operating conditions in the table with reference to an ambient air temperature of 40° C. For other ambient temperatures, the values must be corrected by the factors from the "Derating factors" table.

Table 6- 1 Cable cross-section and current-carrying capacity

Cross-section in mm ²	Current-carrying capacity rms; AC 50/60 Hz or DC for routing type		
	B1 in A	B2 in A	C in A
Electronics (according to EN 60204-1)			
0.20	-	4.3	4.4
0.50	-	7.5	7.5
0.75	-	9	9.5
Power (according to EN 60204-1)			
0.75	8.6	8.5	9.8
1.00	10.3	10.1	11.7
1.50	13.5	13.1	15.2
2.50	18.3	17.4	21

Table 6- 2 Derating factors for power and signal cables

Ambient air temperature in °C	Derating factor according to EN 60204-1 Table D1
30	1.15
35	1.08
40	1.00
45	0.91
50	0.82
55	0.71
60	0.58

6.3.1.2 Rotating the connector on the motor

You can rotate power connectors and signal connectors within a limited range of angles.

Use a suitable socket connector to rotate the angle plug.

Unscrew and open the socket connector completely to avoid damaging the pin contacts.

Note

Rotating the connectors

- Do not exceed the permissible range of rotation.
- To ensure the degree of protection, do not rotate more than 10 times.

Rotatability of the power connector and signal connector

Table 6- 3 Rotation range of the power connector ①

Motor	Connector size of the power connector ①	Angle α	Angle α'	Drawing
1FK2□03	M17	205	29	
1FK2□04		205	25	
1FK2□05		228	35	
1FK2□06	M23	222	40	
1FK2□08		222	46	
1FK2□10	M40	228	48	

Table 6- 4 Rotation range of the signal connector ②

Motor	Connector size of the signal connector ②	Angle β	Angle β'	Drawing
1FK2□03	M17	209	25	See table "Rotation range of the power connector"
1FK2□04		205	25	
1FK2□05		215	48	
1FK2□06		215	41	
1FK2□08		215	46	
1FK2□10		215	57	
		210	48	

Table 6- 5 Maximum rotating torque for the connectors

Connectors	Max. torque when rotating
Connector M17	8 Nm
Connector M23	12 Nm
Connector M40	20 Nm

The motors are equipped with SPEED-CONNECT connectors.

You can also connect quick-connection cables with SPEED-CONNECT to motor connectors as conventional cables with screw locks (fully threaded).

Note

We recommend cables with SPEED-CONNECT because they are easier to use.

Establishing a SPEED-CONNECT connection

Procedure

Note

- Only tighten the connector by hand.
- Do not use any wrenches or similar tools.

1. Ensure that the union nut of the SPEED-CONNECT connector is rotated to the end stop in the direction of the "open" arrow.
2. Align the SPEED-CONNECT connector so that the triangles on the top of the connectors are opposite one another.



3. Push the power connector onto the motor connecting socket as far as it will go.
4. Turn the union nut by hand in the direction of "close" through at least 45° (position A) or up to the end stop (position B)



- A Minimum locking
- B Maximum locking up to the end stop

Note

A secure connection is only guaranteed from position A onward.

You have established a secure connection.

Releasing a SPEED-CONNECT connection

Procedure

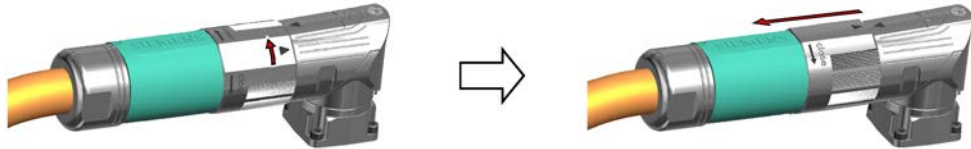

1. Turn the union nut of the SPEED-CONNECT connector in the direction of "open" to the end stop. The triangles on the top of the connectors must be opposite one another.
2. Withdraw the connector.

Note

Pull out the connector at the connector itself, do not pull on the cable.

You have disconnected the SPEED-CONNECT connection.



6.3.1.3 Routing cables in a damp environment

Note

If the motor is mounted in a humid environment, the power and signal cables must be routed as shown in the following figure.

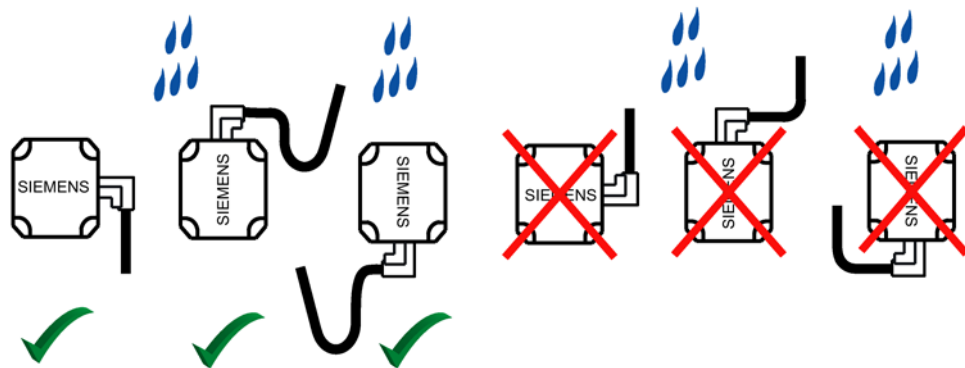
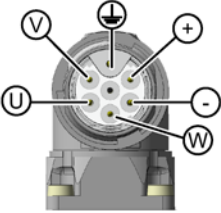
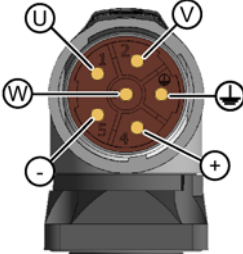
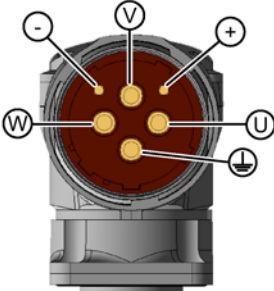

Figure 6-1 Routing cables in a damp environment

6.3.2 Line connection

Designs of the power connectors

The 1FK2 is equipped with the following power connectors depending on the size and power rating.

Round connector M17	Round connector M23	Round connector M40
		
Brake connection 24 V: "+" = BD1+; "-" = BD2-		

The power connectors can be rotated within a certain range.

You will find precise information on the equipment of the motors and the rotation angles in Chapter:

 Rotating the connector on the motor (Page 54)

6.3.3 Signal connection

Design of the signal connector

The signal connector of the 1FK2 is an M17 round connector.
The connector pin assignment is as follows.

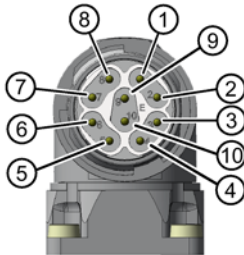
M17 signal connector, with DRIVE-CLiQ			
			
1	TX-P	6	RX-N
2	TX-N	7	-
3	-	8	-
4	-	9	24 V
5	RX-P	10	0 V

The signal connectors can be rotated within a certain range.

You will find precise information on the rotation angle in Chapter:

 Rotating the connector on the motor (Page 54)

6.3.4 Connecting to a converter

Selecting and connecting the cables

- Use prefabricated MOTION CONNECT cables from SIEMENS or shielded connecting cables.
- The prefabricated MOTION CONNECT cables reduce installation costs and increase the operational reliability

Note

The cable shielding, made up of as many strands as possible, must have a high electrical conductivity. Braided shields made of copper or aluminum are well suited.

When connecting, comply with the following:

- Connect the shield to the converter.
- Keep the unshielded cable ends as short as possible.
- To ensure good discharging of high-frequency currents, provide contacting over a large surface area.

Connection diagram for connection of the 1FK2 motor to the S120 Power Module and Motor Module Booksize and Compact with a MOTION-CONNECT cable

For connector size M17

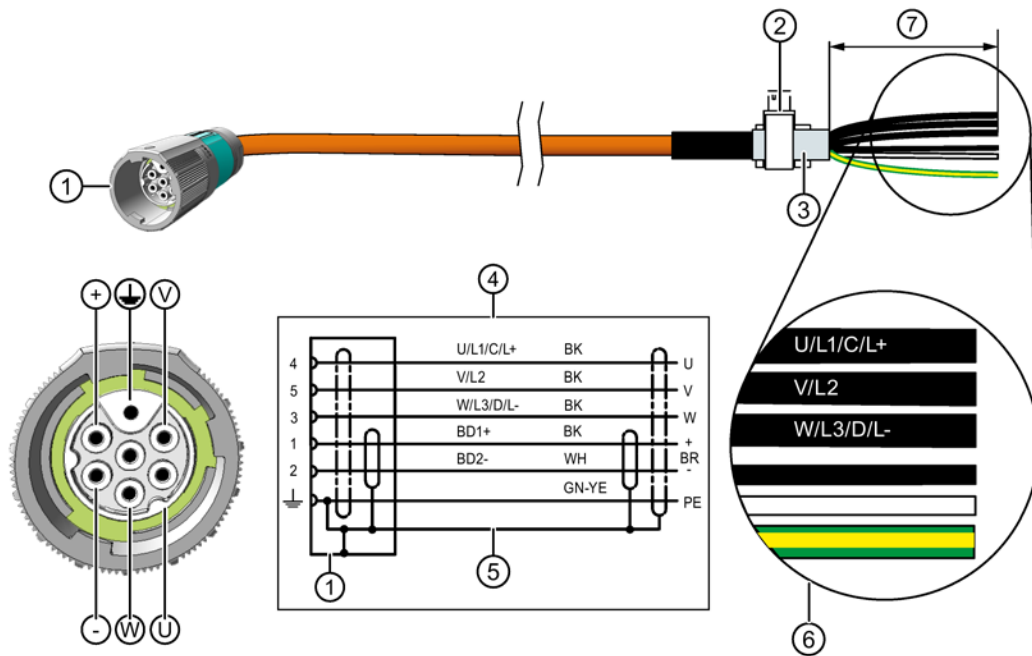

- 1 SPEED CONNECT connector, size M17
- 2 Terminal for the cable shield
- 3 Cable shield
- 4 Connection diagram
 U; V; W = power cables, 1.5 mm², each cable with separate shielding
 BD1+ and BD2- = brake cable without lettering, 1.5 mm², shielded together
 PE = protective conductor
- 5 Cable shield
- 6 Conductor designations
- 7 Recommended length of the cable ends: 105 mm

For connector size M23

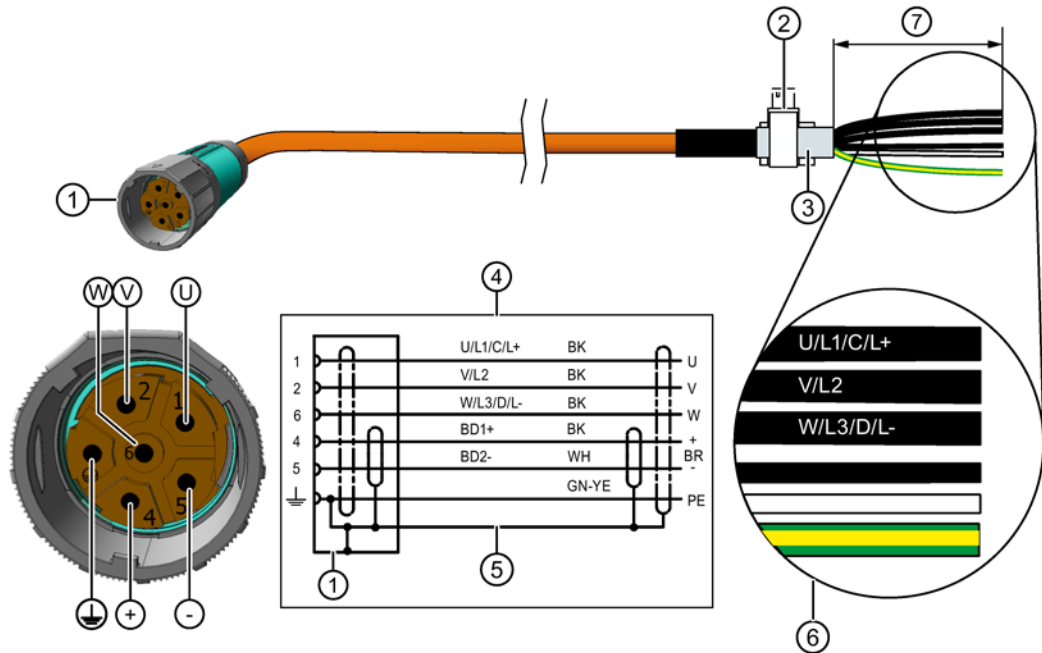

- 1 SPEED CONNECT connector, size M23
- 2 Terminal for the cable shield
- 3 Cable shield
- 4 Connection diagram
U; V; W = power cables, 1.5 mm², each cable with separate shielding
BD1+ and BD2- = brake cable without lettering, 1.5 mm², shielded together
PE = protective conductor
- 5 Cable shield
- 6 Conductor designations
- 7 Recommended length of the cable ends: 105 mm

For connector size M40

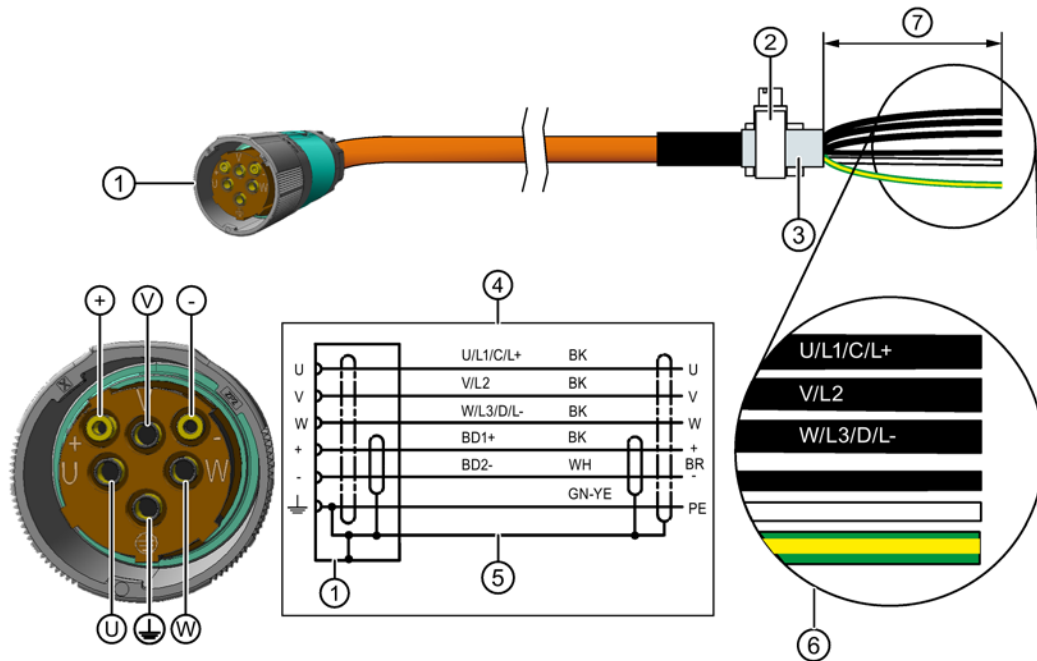

- 1 SPEED CONNECT connector, size M40
- 2 Terminal for the cable shield
- 3 Cable shield
- 4 Connection diagram
 U; V; W = power cables, 1.5 mm², each cable with separate shielding
 BD1+ and BD2- = brake cable without lettering, 1.5 mm², shielded together
 PE = protective conductor
- 5 Cable shield
- 6 Conductor designations
- 7 Recommended length of the cable ends: 105 mm

Lock the round connector properly on the motor

You will find information on locking in Chapter:

 Rotating the connector on the motor (Page 54)

Connection diagram for connection of the signal line for motor 1FK2 on the S120

The connection is made on a signal line with connector M17, 10-pin and RJ45 connector

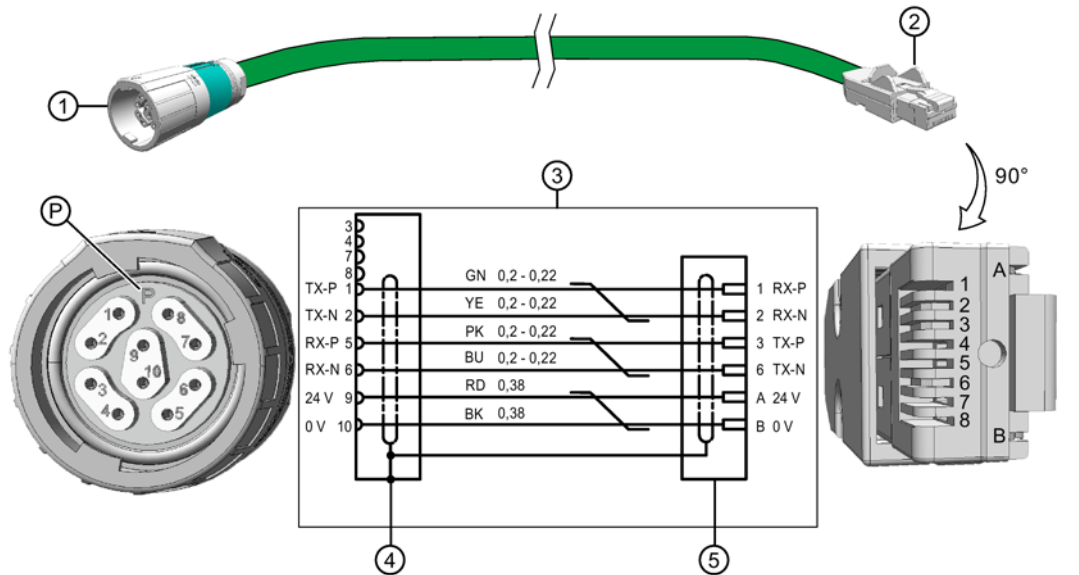

- | | | | |
|---|-----------------------------|---|---|
| 1 | M17 round connector, 10-pin | 4 | Pin assignment of M17 round connector, 10-pin |
| 2 | RJ45/IP20 connector | 5 | Pin assignment of the RJ45 connector |
| 3 | Connection diagram | P | 0° coded |

Lock the round connector properly on the motor

You will find information on the locking in Chapter

 Rotating the connector on the motor (Page 54)

7.1 Safety instructions

 WARNING
Electric shock when connected to inadequately grounded line supplies Connecting a motor to an inadequately grounded line supply can result in death, severe injury and damage to the motor if a fault occurs. <ul style="list-style-type: none">• Connect motors, as part of the drive system, to TN and TT line supplies with a grounded neutral point or to IT line supplies.• Ensure that the SINAMICS devices and motors are compatible with the residual current device according to EN 61800-5-1 before you connect the devices and motors to the line supply using residual current devices (RCDs).• For line supplies with grounded line conductor, e.g. TT line supplies, use an isolating transformer with grounded neutral point (on the secondary side) between the line supply and the drive system, so that the motor insulation is not overstressed.• When connected to IT line supplies, a monitoring device must signal the first fault between an active part and ground. Eliminate this fault immediately.

 WARNING
Electric shock caused by high touch voltages for brake cables For motor cables with integrated brake cable, when the motor is operated, the motor can charge the brake cable up to hazardous voltage levels. Coming into contact with the conductors or the shield of the brake cable can result in death or serious injury. <ul style="list-style-type: none">• Use motor cables with separate, shielded brake cables and connect the shield of the brake cable at both ends.

 **WARNING**

Electric shock when checking the insulation resistance

During the measurement and immediately afterward, high voltages can be present at the terminals that can cause death or severe injury as result of an electric shock.

Contact with live parts causes electric shocks.

- Work on power installations must only be performed by qualified personnel.
- Before you begin measuring the insulation resistance, read the operating manual for the insulation resistance meter you are going to use.
- Never touch the terminals when making measurements or immediately after the measurement.
- Check the connected supply feeder cables to ensure that the line supply voltage cannot be connected.

 **WARNING**

Danger to life due to unintentional starting of the drive unit

Unintentional starting of the drive unit can cause death or severe injury.

- Make sure that the drive unit cannot be started accidentally.
- Post a warning notice to this effect at the point where the switch is located.

 **WARNING**

Danger to life caused by machine movement and loose objects

Machine movement and loose objects that can fall out or be ejected can cause death or severe injury.

- Ensure that the machine has been completely installed and all of the setting work completed.
- Ensure that nobody is at risk when the machine is switched on.
- Before switching on, check that there are no loose objects in or on the motor that can fall or be flung off.
- Before switching on, check that all safety guard covers are installed and all safety equipment functions correctly.

 **CAUTION**

Burns as a result of touching hot surfaces

In operation, the motor enclosure can reach high temperatures, which can cause burns if touched.

- Do not touch any hot surfaces.
- Allow the motor to cool down before starting any work.
- Use the appropriate personnel protective equipment, e.g. gloves.

NOTICE

Thermal damage to temperature-sensitive parts

Some parts of the frame of electric motors can reach temperatures that exceed 100° C. If temperature-sensitive parts, e.g. electric cables or electronic components, come into contact with hot surfaces, these parts could be damaged.

- Ensure that no temperature-sensitive parts are in contact with hot surfaces.

NOTICE

Motor damage when the maximum speed is exceeded

The maximum speed n_{\max} is the highest permissible operating speed. The maximum speed is specified on the rating plate.

Impermissible speeds can cause damage to the motor.

- Ensure that the maximum permissible speed is not exceeded. Realize this using a suitable control system or activate the speed monitoring function in the drive.

NOTICE

Motor damage caused by uneven running or abnormal noise

The motor can be damaged by improper handling during transport, storage or installation. If a damaged motor is operated, this can damage the winding or bearings and could even destroy the system.

- In case of uneven running or abnormal noise, switch off the motor.
- Identify the cause.

NOTICE

Premature wear of the motor holding brake when operated outside its permissible voltage range

Operating the motor holding brake outside its permissible voltage range at the motor connection will damage the brake.

- Ensure that the motor holding brake is only operated within its permissible voltage range.

7.2 Checklists for commissioning

Note

Required checks

The lists below do not purport to be complete. It may be necessary to perform additional checks and tests appropriate for the situation specific to the particular installation site.

Before commissioning the system, check that it is properly installed and connected.

Commission the drive system according to the Operating Instructions of the converter or inverter being used.

Checklists for commissioning 1FK2 motors

Thoroughly familiarize yourself with the safety instructions and observe the checklists below before starting any work.

Table 7- 1 Checklist (1) - general checks

Check	OK
Are all of the necessary components of the configured drive line-up available, correctly dimensioned, installed and connected?	
Is the manufacturer documentation for the system components (e.g. drive system, brake) available?	
Is the motor type to be commissioned known? (e.g. 1FK2 ___-____-____)	
Are the environmental conditions in the permissible range?	

Table 7- 2 Checklist (2) - checks regarding the mechanical system

Check	OK
Have all touch protection measures for moving and live parts been fitted and are they functional?	
Has the motor been correctly mounted and aligned?	
Can you rotate the rotor without it touching the stator?	
Have all fastening screws, fastening elements, and electrical connections been tightened with the prescribed torques and properly attached?	
Do the operating conditions correspond to the data specified on the rating plate?	
Do the output elements have the correct setting conditions according to type? Examples: <ul style="list-style-type: none"> • Have the couplings been aligned and balanced? • Has the belt drive tension been correctly adjusted? • Have the gear tooth flank and gear tooth tip play as well as radial play been correctly adjusted for geared outputs? 	

Table 7- 3 Checklist (3) - checks regarding the electrical system

Check	OK
Has the motor been connected so that it rotates in the specified direction?	
Have the minimum insulation resistance values been maintained?	
Have the grounding and equipotential bonding connections been correctly established?	
Is the specified limit speed n_{max} maintained during the operation on the converter?	

Table 7- 4 Checklist (4) - Monitoring equipment checks

Check	OK
Has it been ensured that speeds higher than the maximum speed n_{max} cannot be reached?	
Have all supplementary motor monitoring devices been correctly connected and are they working properly?	

Table 7- 5 Checklist (5) - Cooling system checks

Check	OK
<p>Natural cooling</p> <p>Have you adapted the torque and power of the motor to the ambient conditions? You will find information on the derating in the configuration manual. Observe the information provided in the converter operating instructions.</p>	

Table 7- 6 Checklist (6) - Checks regarding the optional brake

Check	OK
Is the brake open when the operating voltage is applied?	
Does the brake open and close correctly?	

7.3 Commissioning procedure

Preconditions

- You have mounted and connected the motor correctly.
- Make sure that the frequency converter is correctly parameterized.

Procedure

- Launch the commissioning tool in the converter.
- Follow the steps of the commissioning tool to commission the motor.

You have commissioned the motor.

□

Switching off

- Switch off the motor at the frequency converter.

7.4 Switching on and switching off

Note**EMERGENCY OFF**

To avoid accidents, inform yourself about the EMERGENCY OFF function before you switch on the system.

The motor is switched on and off using the frequency converter.

- For more information on this topic, see the chapter in the Operating Instructions for the converter.

Switching on

Precondition

- Ensure that the frequency converter is correctly parameterized.
- Check whether sufficient heat is dissipated from the motor.

Procedure

1. Switch on the motor at the frequency converter.
2. Observe any uneven running and abnormal noise of the motor.
3. Check the function of the safety equipment.
4. Check whether the motor reaches the required parameters

You have switched on the motor.





Switching off

- Switch off the motor at the frequency converter.

8.1 Safety instructions

 WARNING
Do not remove covers when the motor is running Rotating or live parts are dangerous. Death, serious injury, or material damage can result if the required covers are removed. All covers that prevent personnel from coming into contact with active or rotating parts, ensure compliance with the required degree of protection, or ensure proper air guidance and, in turn, effective cooling must not be opened/removed during operation.

 WARNING
Faults in operation Deviations from normal operation (e.g. increased power consumption, temperature, or vibration levels, unusual noises or smells, tripping of monitoring equipment, etc.) indicate that the machine is not functioning properly. This can cause faults that can result in eventual or immediate death, severe personal injury, or material damage. Immediately inform the maintenance personnel. If in doubt, shut down the motor immediately, taking into account the plant-specific safety regulations.

 CAUTION
Danger of burns The temperature of certain parts of the motor can exceed 100 °C. Physical contact can cause serious burns. Check the temperature of the parts before touching them and take appropriate protective measures if necessary.

8.2 Switching on and switching off

Note

EMERGENCY OFF

To avoid accidents, inform yourself about the EMERGENCY OFF function before you switch on the system.

The motor is switched on and off using the frequency converter.

- For more information on this topic, see the chapter in the Operating Instructions for the converter.

Switching on

Precondition

- Ensure that the frequency converter is correctly parameterized.
- Check whether sufficient heat is dissipated from the motor.

Procedure

1. Switch on the motor at the frequency converter.
2. Observe any uneven running and abnormal noise of the motor.
3. Check the function of the safety equipment.
4. Check whether the motor reaches the required parameters

You have switched on the motor.



Switching off

- Switch off the motor at the frequency converter.

8.3 During operation

While the motor is operating, ensure that the specified parameters are maintained.

Make sure that:

- The power consumption is in the specified range
- Cooling is ensured
- There is no abnormal motor noise
- The motor does not overheat

8.4 Stoppages



Measures for stationary motors that are ready for operation

- Operate the motor regularly, at least once a month, in the event of longer non-operational periods.

NOTICE

Damage due to improper storage

The motor can be damaged if it is not stored properly.

- Before taking the motor out of service for extended periods of time, take suitable anti-corrosion and preservation measures and ensure that the motor is kept dry.
- If the motor is out of service for extended periods of time, follow the instructions in Chapter:
 Storage (Page 41)
 - On recommissioning after an extended period out of service, perform the inspections and measures described in the chapter stated.
 Commissioning (Page 65)
 - Before switching on for recommissioning, follow the instructions in Chapter:
 Switching on and switching off (Page 71)

8.5 Cleaning

WARNING

Electric shock when cleaning due to failing to observe the protection class

When cleaning, especially with high-pressure cleaning equipment, water can enter energized parts and cause an electric shock.

- Clean the motor in a manner appropriate for its protection class.
- Avoid pressurized water on connectors, terminal boxes, and other live parts.

Clean the motor of dust and dirt as required. In this way, you ensure adequate heat dissipation.

Faults and their rectification

⚠ WARNING

Operation without functioning protective devices

Operation without functioning protective devices can cause death or severe injury.

- Operate the motor, even in test operation, only with functioning protective devices.

NOTICE

Motor damage caused by faults

Faults can cause damage to the motor.

- Correct the fault cause as specified in the remedial measures.
- Repair any damage to the machine/motor.

If there are deviations from normal operation or if faults occur, proceed as follows.

- Identify the fault using the "Possible faults" table.
Also observe the converter messages.
- Try to correct the fault using the "Fault causes and remedial measures" key table.

Table 9- 1 Possible faults

Fault	Fault cause (see "Fault causes and remedial measures" key table)																	
	A	B	C	D	E	F	G	H	I	J	K	L	M	N	O	P	Q	R
Motor does not start	A	B																
Motor starts slowly	A		C		F													
Humming sound when starting			C		F													
Humming sound in operation	A		C		F													
High temperature rise under no-load operation				D		I												
High temperature rise under load	A		C			I												
Uneven running								J	K									
Grinding sound, running noise											L							
Radial vibrations												M	N	O	P			R
Axial vibrations														O		Q		R

Table 9- 2 "Fault causes and remedial measures" key table

No.	Fault cause	Remedial measures
A	Overload	Reduce load
B	Interruption of a phase in the supply cable / motor winding	Check the frequency converter and supply cables, measure the winding resistances and insulation resistances, repair after consultation with manufacturer
C	Interrupted phase in the feeder cable after switching on	Check the frequency converter, supply cables and the winding resistances
D	Converter output voltage too high, frequency too low	Check the settings on the frequency converter, perform automatic motor identification
F	Winding short-circuit or phase short-circuit in stator winding	Measure the winding resistances and insulation resistances, repair after consultation with the manufacturer, if required, replace the motor
I	Heat dissipation impeded by dirt	Clean the surface of the drives and ensure that the cooling air can flow in and out unimpeded
	Cooling air inlet/outlet is blocked by foreign bodies	Remove the reason for the blocking and ensure that the cooling air can flow in and out unimpeded
J	Insufficient shielding for motor and/or encoder cable	Check the shielding and grounding
K	Excessive drive controller gain	Adjust the controller
L	Rotating parts are grinding	Determine cause and adjust parts
	Foreign bodies inside the motor	Replace the motor
	Bearing damage	Replace the motor
M	Rotor not balanced	Replace the motor
N	Rotor out of true, shaft bent	Consult the manufacturer
O	Poor alignment	Align motor set, check coupling
P	Coupled machine not balanced	Re-balance coupled machine
Q	Shocks from coupled machine	Check coupled machine
R	Fault originating from the gearbox	Adjust/repair gearbox

If the fault still cannot be resolved after taking the measures stated above, please contact the manufacturer or the Siemens Service Center.

10.1 Safety instructions

If you have any questions, please contact the manufacturer, quoting the machine type and serial number.

<p> WARNING</p> <p>Danger to life when live parts are touched</p> <p>Death or serious injury can result when live parts are touched.</p> <ul style="list-style-type: none">• Only work on electrical equipment if you are appropriately qualified.• Always comply with the local national safety regulations when working on electrical equipment. <p>Generally, six steps apply when establishing safety:</p> <ol style="list-style-type: none">1. Prepare for shutdown and notify all those who will be affected by the procedure.2. Disconnect the machine from the power supply.<ul style="list-style-type: none">– Switch off the machine.– Wait until the discharge time specified on the warning labels has elapsed.– Check that it really de-energized, from phase to phase and phase to protective conductor.– Check that every auxiliary circuit is de-energized.– Ensure that the motors cannot move.3. Secure SIMOTICS S motors against unintentional movements that generate a voltage at the terminals.4. Identify all other dangerous energy sources, e.g. compressed air, hydraulic systems or water.5. Isolate or neutralize all hazardous energy sources, for example by closing switches, grounding or short-circuiting, or closing valves.6. Take measures to prevent reconnection of the energy sources.7. Make sure that the machine is completely locked ... and that you have the right machine. <p>After you have completed the work, restore operational readiness by performing the above steps in the reverse order.</p>
--

 **WARNING**

Danger to life due to slipping on leaked oil

Leaked oil can result in slipping or falling and cause death or severe injury.

- Prevent oil from leaking
- Absorb leaked oil immediately with a binding agent for oil or similar.
- Rough up the hazardous location.
- Mark the hazardous location.

 **WARNING**

Danger to life due to unintentional starting of the drive unit

Unintentional starting of the drive unit can cause death or severe injury.

- Make sure that the drive unit cannot be started accidentally.
- Post a warning notice to this effect at the point where the switch is located.

 **CAUTION**

Burning hazard caused by hot surfaces

Some parts of the frame of electrical machines can reach temperatures in excess of 100°C. Touching components when the machine is in operation can cause burns.

- Do not touch frame parts while the machine is in operation or immediately after machine operation.
- Allow frame parts to cool off before starting any work.

 **CAUTION**

Danger of scalding from the hot oil exiting the unit

Exiting hot oil can cause burns.

- Before starting any work, wait until the oil has cooled down to below 30° C.

 **CAUTION**

Chemical burns and irritations caused by chemical cleaning agents

Chemical cleaning agents can be caustic or emit dangerous fumes. If these come into contact with skin or if you inhale the fumes, this can cause injuries (e.g. chemical burns on the skin or respiratory passages, or skin irritation).

- During cleaning, make sure that appropriate methods of extracting fumes are in place and that you wear the appropriate protective gear (e.g. gloves, goggles, face masks).
- If using chemical cleaning agents, observe the instructions and any warnings provided in the relevant safety data sheet. Chemical cleaning agents must be suitable for use with the machine's components, particularly where plastic components are concerned.

 CAUTION**Injuries caused by stirred-up foreign bodies and dust when working with compressed air**

When you clean using compressed air, this can stir up dust, metal chips and cleaning agents, and so cause injuries.

- When cleaning using compressed air, make sure you use suitable extraction equipment and wear protective equipment (safety goggles, protective suit, etc.).

 WARNING**Danger to life when lifting and transporting**

Incorrect lifting and transport operations, devices and equipment that are unsuitable or damaged can result in death, severe injury and/or damage to property.

- The motor must not be lifted or transported by means of the power connector or signal connector.

10.2 Inspection and maintenance

10.2.1 Service and inspection intervals

General

To avoid motor faults, perform maintenance work, inspections and overhauls at regular intervals.

Note

Inspection if there are faults or unusual conditions

Unusual conditions or faults that represent overstressing of the motor, e.g. overload or short-circuit, can result in consequential damage to the machine.

Immediately perform an inspection when faults or exceptional conditions occur.

Maintenance measures, inspection/maintenance times intervals

The maintenance intervals depend on the operating conditions.

- Adapt the maintenance intervals to match the local conditions, such as pollution/dirt, switching frequency, load, etc.
- Perform the following maintenance measures as specified in the table.

Maintenance and repair of the motor can be performed by Siemens Service Centers throughout the world.

Contact your personal Siemens contact if you require this service.

NOTICE
Improper maintenance
Service and maintenance must only be performed by properly authorized qualified personnel.
Use original Siemens parts only.

Table 10- 1 Maintenance measures after operating times or intervals

Operating times and intervals	Measure
Operation	
Daily; if possible, more frequently during operation.	Monitor and check the motor for unusual noise, vibrations, and changes.
When required or after 25000 hours of operation	Replace motor

10.2.2 Cleaning



WARNING

Electric shock when cleaning due to failing to observe the protection class

When cleaning, especially with high-pressure cleaning equipment, water can enter energized parts and cause an electric shock.

- Clean the motor in a manner appropriate for its protection class.
- Avoid pressurized water on connectors, terminal boxes, and other live parts.

Clean the motor of dust and dirt as required. In this way, you ensure adequate heat dissipation.

10.2.3 Motor replacement on reaching the bearing life

Motor bearings are wearing parts. They must be replaced after a defined number of operating hours.

At medium loads, the motor bearings last approx. 25000 h.

The procedure for replacing the motor bearing depends on the size of the motor.

For 1FK2□03 ... 1FK2□05 motors, it is not possible to replace the motor bearings. Replace these motors in their entirety.

Replacement of the motor bearings is only intended as from 1FK2□06.

Note

To maintain the functional reliability of the motor, you must also replace the encoder when you replace the motor bearings.

You will find information on replacing the motor bearings and the encoder in the following chapter.



Repair (Page 84)

Especially favorable ambient conditions, such as low average speed, low radial force (transverse force) and vibration load can prolong the interval until motor replacement.

Note

Premature bearing and motor replacement

Harsh operating conditions, e.g. continuous operation at n_{max} , high vibration/shock loads, frequent reversing duty reduce the bearing or motor replacement interval by up to 50 %.

10.3 Repair

10.3.1 How to replace a 1FK2 motor

Requirement

The new motor has the same article number as the motor to be replaced.

Note

You can replace a motor with a singleturn encoder AS22DQC (1FK2□□□_□□□□□-□S□□) with an otherwise identical motor with a multiturn encoder AM22DQC (1FK2□□□_□□□□□-□M□□) without recommissioning.

Note

If you want to replace the motor with a motor with a different article number, you must perform converter commissioning after replacing the motor.

You will find more precise information in the manual for the converter in question

Procedure

1. Verify absence of operating voltage to the converter.

 WARNING
--

Danger to life due to unintentional starting of the drive unit

Unintentional starting of the drive unit can cause death or severe injury.
--

- | |
|--|
| <ul style="list-style-type: none">• Make sure that the drive unit cannot be started accidentally.• Post a warning notice to this effect at the point where the switch is located. |
|--|

2. Replace the motor.

CAUTION

Burns as a result of touching hot surfaces

In operation, the motor enclosure can reach high temperatures, which can cause burns if touched.

- Do not touch any hot surfaces.
- Allow the motor to cool down before starting any work.
- Use the appropriate personnel protection equipment, e.g. gloves.

- Release the motor connector. More detailed information is provided in Chapter:



Notes for connecting the round connector to the motor (Page 54)

- Release the motor mounting screws.

- Remove the motor.

- Mount and install the new motor. More detailed information is provided in Chapter:



Mounting instructions (Page 46)

- Connect the motor plug. You will find detailed information in Chapter:



Notes on connecting the round connectors to the motor (Page 54)

3. Switch the converter on.

You have replaced the motor.



Decommissioning and disposal

11.1 Safety instructions



WARNING

Risk of injury through falling motors or machine components

Motors and machine components can fall when being dismantled from the machine. They can cause serious injury or property damage.

- Secure the machine components being dismantled to prevent them falling.

11.2 Decommissioning

11.2.1 Removing the motor

The removal of the motor must be performed and/or supervised by qualified personnel with appropriate expert knowledge.

Removing the motor from the machine

Procedure

1. Check that all parts of the motor are in a no voltage condition.
2. Let the motor cool down enough so that you are not burnt.
3. Disconnect all electrical connections. You will find information about this in Chapter  Rotating the connector on the motor (Page 54)
4. Remove the fixing elements from the motor.
5. Transport the motor to a suitable location for disposal.

You have removed the motor.



Dispose of the motor in accordance with the local legal requirements.

11.2.2 Dismantling the motor

Note

The rotor in a motor containing permanent magnets must only be removed by the manufacturer.

Contact the Siemens Service Center.

11.3 Disposal

Recycling and disposal



For environmentally-friendly recycling and disposal of your old device, please contact a company certified for the disposal of waste electrical and electronic equipment, and dispose of the old device as prescribed in the respective country of use.

Technical data and characteristics

You will find the technical data for the various frame sizes of the motors in the configuration manual in Chapter "Technical data and characteristics".

Dimension drawings

The motor has the following dimensions in the following frame sizes:

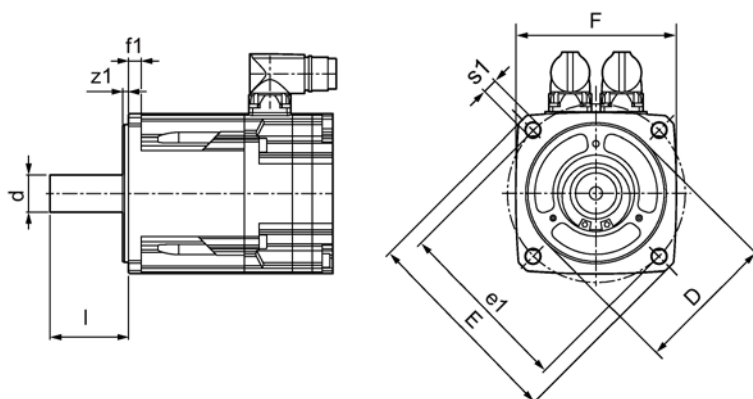

Frame size (shaft height) in mm	Identification letter in the dimension draw- ing	Unit	30	40	48	52	63	80	100
Flange width	F	mm	60	80	95	105	125	155	192
Width across corners	E	mm	81	105	120	135	158	200	252
Centering diam- eter	D	mm	50	70	80	95	110	130	180
Centering edge length	z1	mm	2.5	3	3	3	3.5	3.5	4
Pitch circle	e1	mm	70	90	100	115	130	165	215
Through-hole	s1	mm	5.5	6.5	6.5	9	9	11	14
Flange thickness	f1	mm	5	7	9	10	11	12	13
Bolts for mount- ing by customer			M5 × 16	M6 × 20	M6 × 20	M8 × 25	M8 × 25	M10 × 25	M12 × 30
Washers ISO 7092		mm	9	11	11	15	15	18	20
Shaft extension	d × l	mm	14 × 30 1) 11 × 23 2)	19 × 40	19 × 40	19 × 40	24 × 50	32 × 50	38 × 80
Fit of the shaft			h6	k6					

1) Standard

2) Alternative shaft extension

You will find further dimensions in the dimension drawings in the relevant catalog.

Index

C

Certificates
 EAC, 23
 EC Declaration of Conformity, 23
 UL and cUL, 23
Commissioning, 68
Correct usage, 21, 21

D

Degree of protection, 26

H

Holding brake, 34
Hotline, 5

I

Inspection and maintenance, 79

L

Lifting and transporting the motor, 38

M

Maintenance intervals, 82
Motor replacement
 Bearing damage, 83

N

Noise emission, 26

R

Rating plate, 29
RoHS, 23

S

Siemens Service Center, 5
Sound pressure level, 26

T

Target group, 3
Technical features, 24
Technical Support, 5
Training, 5
Transportation, 38

V

Vibration response, 49
Vibration severity grade, 49

Siemens AG
Digital Factory
Motion Control
P.O. Box 3180
91050 ERLANGEN
GERMANY

Subject to change without prior notice

For more info on
SIMOTICS,
please scan the QR
code.



www.siemens.com/automation