

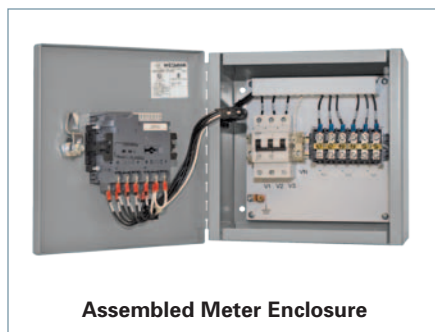

WinPM.Net



Powermanager Software



Assembled Meter Enclosure



Power Meters

Scan to connect online to the most up-to-date version of this Section of SPEEDFAX.



## contents

### Power Distributions Solutions

#### Introduction

Power Monitoring Systems Overview	9-2
Intelligent Metering and Control Devices	9-3

#### Power Meters

PAC3100	9-4
PAC3200	9-5
PAC4200	9-6
9410	9-7
9810	9-8 – 9-9
Enclosed Meters	9-10
Branch Circuit Monitoring /SEM3 Embedded Metering	9-11 – 9-18
Enclosures for External Applications	9-19 – 9-20
MD Meter – BACnet MSTP/IP standalone meter	9-21
Low-voltage Current Transformers	9-22 – 9-23

#### Energy Management Software

Powermanager Software	9-24
WinPM.Net Software	9-25

#### Application Engineering

Digitalization for Smart Infrastructure	9-26
Services	9-27

Siemens recognizes that high performance facilities make for high performance business. Energy is the lifeline of your business, and better efficiency and sustainability can have a large positive impact on your bottom line.

Energy Management and Control Systems from Siemens are complete enterprise solutions that help you manage the energy costs and availability of your business. With our advanced meters and controls, you can be sure to use only the energy you need, when you need it.

Siemens Power Distribution Solutions contribute toward achieving LEED® certification and provides the needed energy metering data for federal/local government energy reductions programs.

### Features and Benefits of Siemens Power Distribution Solutions:

- |   |  |
|---|--|
| <ul style="list-style-type: none"> <li>■ Power Quality Reliability &amp; Analysis</li> <li>■ Utilities Cost Allocation &amp; Billing</li> <li>■ Utilities Usage Aggregation</li> <li>■ Load Preservation</li> <li>■ Equipment Monitoring</li> <li>■ Facility Monitoring &amp; Automation</li> <li>■ Sequence of Event Recording</li> <li>■ Preventative Maintenance</li> <li>■ Electrical Asset Management</li> </ul> | <h4>Additional Products/Services</h4> <ul style="list-style-type: none"> <li>■ Branch Circuit Monitoring</li> <li>■ Sub-Billing and Cost Allocation</li> <li>■ Application Engineering</li> <li>■ Services Agreements</li> <li>■ Network/Communication Components</li> <li>■ Integration with Existing</li> <li>■ SCADA/BAS Systems</li> <li>■ Incorporation of Third Party Devices</li> </ul> |
|---|--|

For Technical Assistance Contact: **1-800-333-7421**

Create Support Ticket Online:

<https://support.industry.siemens.com/my/WW/en/requests#createRequest>

PDS Request for Information / Request for Quote:

[www.usa.siemens.com/pds-request](http://www.usa.siemens.com/pds-request)

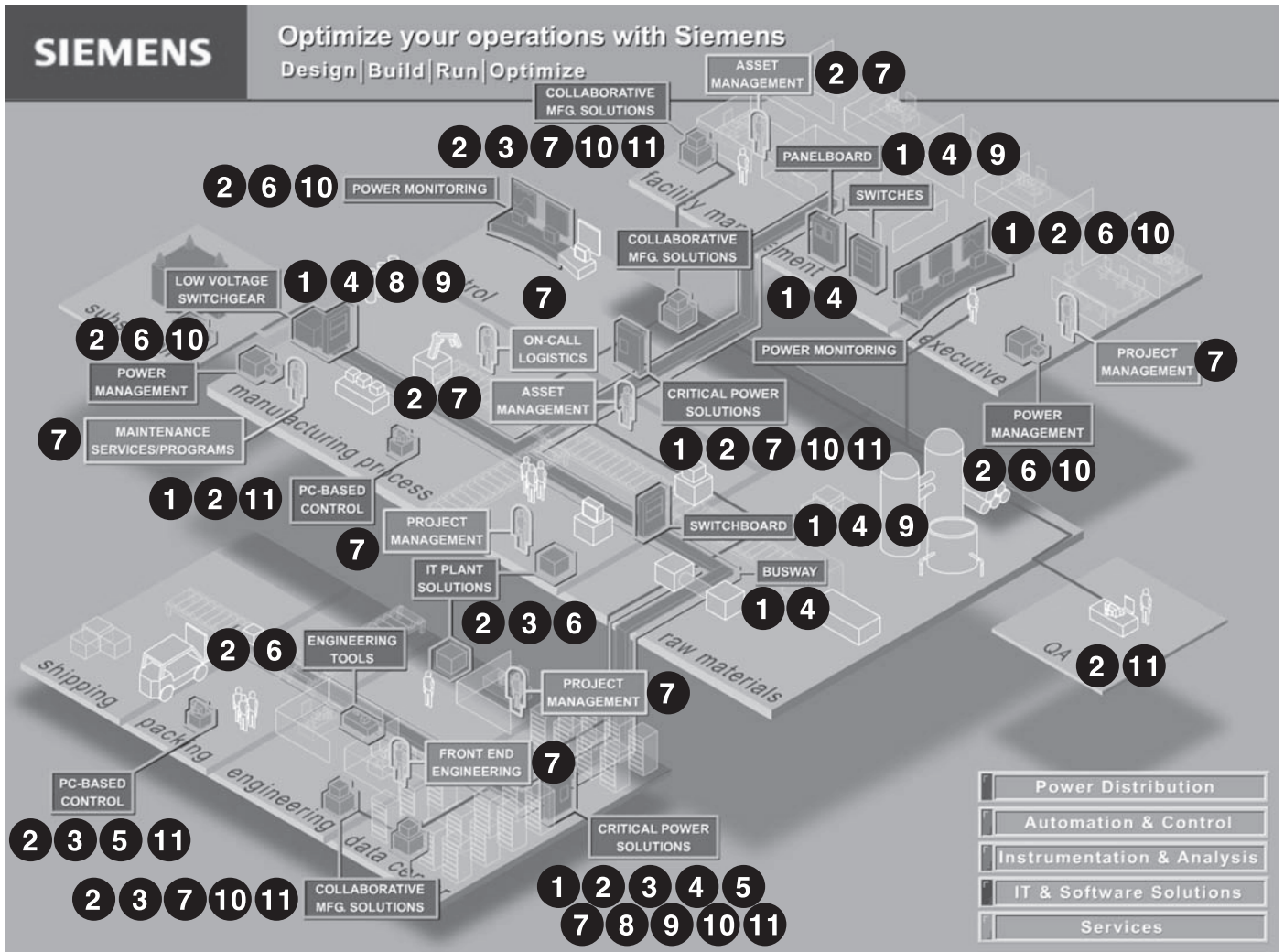

## 1. Power Meters

Siemens power monitors combine the best of new technologies and proven practices. Monitor critical loads, power quality, and demand via the web directly from the meters.

## 2. Power Monitoring Software

WinPM.Net and Powermanager web-enabled software facilitates easy, enterprise-wide connection to power monitoring equipment, circuit breakers, and other devices from Siemens and third parties. Access information via the web with unlimited no-cost clients using built-in Web Client via your web browser.

## 3. Communications Networks

Utilize existing Ethernet or RS-485 communications networks to extract the information you need and get it where it needs to go.

## 4. Components

Current Transformers (CTs), Voltage/Potential Transformers (PTs), Power Supplies, Ethernet Switches, Protocol Converters. Siemens can provide everything required for your system.

## 5. Intelligent I/O

Our S7 I/O enables plug-n-play communications with Modbus devices and expands digital and analog input and output functionality of Siemens Systems.

## 6. Billing and Load Allocation Software

Powermanager is the simplified solution for cost allocation, billing & load/demand analysis using your web browser.

## 7. Engineering Services

PDS Application Engineers can help from design through commissioning of even the most demanding power quality and monitoring systems.

## 8. Motor Control Centers

Monitor mains and feeders for critical or power-intensive loads. Communicate with WL, VL and 3VA breakers, SIMOCODE, I/O and devices from other manufacturers. Use Siemens power meters to web-enable new as well as existing MCCs.

## 9. Low- & Medium-Voltage Switchgear

Web-enable switchgear by having Siemens power monitoring as well as breaker status and upload the information to a corporate Intranet or to the Internet. Use MeterMail™ directly from meters for alarm conditions or simple reporting.

## 10. Facility Management Systems

Tie into building automation systems to provide the required power and energy information. Many communications options are available ranging from legacy protocols to XML directly from the power monitors.

## 11. Distributed Control Systems, Automation, and SCADA/Human Machine Interface

Siemens power monitors and/or software can talk to all major vendors' systems.

# Power Distribution Solutions

## Intelligent Metering and Control Devices



	PAC3100	MD Meter	SEM3	PAC3200	PAC4200	9410	9810
<b>Power, energy and demand</b>							
Voltage/current: per phase, average	■	■	■	■	■	■	■
Voltage/current: unbalance	■	■	■	■	■	■	■
Power: real(kW), reactive(kVAR), apparent(kVA), power factor, frequency	■	■	■	■	■	■	■
Energy: bi-directional, import, export	■	■	■	■	■	■	■
Energy kWh: total, net	■	■	■	■	■	■	■
Demand: block, sliding window	■	■	■	■	■	■	■
Demand: thermal predicted	■	■	■	■	■	■	■
<b>Power quality analysis</b>							
Sag(Dip)/Swell disturbances monitoring	■	■	■	■	■	■	■
Voltage disturbance direction detection	■	■	■	■	■	■	■
High speed transient capture	■	■	■	■	■	■	17 µs @ 60 Hz/ 20 µs @ 50 Hz
Harmonics (individual, even, odd, total) up to				THD only	63rd	63rd	63rd
Sampling rate, maximum samples/cycle	64		166	64	204	256	1024
Flicker, harmonics to EN50160, IEC 6100-4-7 / 4-15	■	■	■	■	■	■	■
Configurable for IEEE 519-2014, SEMI/ITIC	■	■	■	■	■	■	■
<b>Data and waveform logs</b>							
Triggered by setpoint, schedule, or external signal	■	■	■	■	■	■	■
Sequence-of-event logs or alarm logs, variable log depth	■	■	■	■	■	■	■
Minimum/maximum logs	■	■	■	■	■	■	■
Onboard Historical logging Memory			4GB (6 mos.)			320MB	2GB
Email data and event logs	■	■	■	■	■	■	■
Waveform recording	■	■	■	■	■	■	■
Waveform in COMTRADE format with FTP	■	■	■	■	■	■	■
GPS time synchronization	■	■	NTP	■	SNTP	NTP/SNTP	NTP/SNTP
Time-stamps, resolution in seconds	■	■	±1 sec	■	±0.1 sec.	±0.1 millisecond.	±0.1 millisecond.
Time synchronization - IEEE1588/IEC61588/PTP	■	■	■	■	■	■	■
<b>Communication ports, protocols and I/O</b>							
( ) = Optional							
USB ports							2 (not activated)
RS-485-only ports	1	1	1	(1)	(1)	1	2
Ethernet ports		1	1	1	1	2 (UTP)	2 (UTP)
PROFIBUS ports				(1)	(1)		
PROFINET ports				(2)	(2)		
Modbus RTU Slave on serial	1	■	■	(1)	(1)	■	■
Modbus RTU Master on serial ports	1	■	■	(1)	(1)	■	■
Modbus/TCP on Ethernet ports	■	■	■	■	■	■	■
Modbus TCP Master over Ethernet	■	■	■	■	■	■	■
BACnet MS/TP	■	■	■	■	■	■	■
BACnet IP on Ethernet ports	■	■	■	■	■	■	■
SNMP	■	■	■	■	■	■	■
DNP 3	■	■	■	■	■	■	■
IEC 61850	■	■	■	■	■	■	■
DHCP	■	■	■	■	■	■ (IP v4/IP v6)	■ (IP v4/IP v6)
RSTP	■	■	■	■	■	■	■
Secure protocols (HTTPS, SFTP, SSH, Secure Modbus)	■	■	■	■	■	■	HTTPS
Ethernet Gateway: 31 other meters accessible via RS-485	■	■	■	■	■	■	■
Multiple masters over Ethernet	2	4	4	3	8	8	8
On-board web server - Realtime, Trending	■	■	■ (CSV output)	■	■	■	■
On-board web server - Waveform display	■	■	■	■	■	■	■
Analog inputs						(16)	(16)
Analog outputs						(8)	(8)
Digital status/counter inputs (standard/optional add-ons)	2		2/(44)	1	2 / (8)	3 / (24)	8 / (24)
Digital relay outputs (control/pulse)	2	1	1	1	2 / (4)	1 / (8)	4 FA/2RO (8RO)®
Integrated display	B/W	B/W	Opt. Color	B/W	B/W	Color	Color
<b>Setpoints, alarming and control</b>							
Setpoints, minimum response time	■	■	■	■	■	½ cycle	½ cycle
Math, logic, trig, log, linearization formulas	■	■	grouping	and/or, > <	and/or, > <	■	■
Multi-condition alarms	■	■	■	■	■	■	■
Email on alarm	■	■	■	■	■	■	■
<b>Revenue metering</b>							
ANSI C12.16 accuracy compliant	1S	■	■	■	■	■	■
ANSI C12.20		0.2	0.2	0.5	0.2	0.2 <sup>2)</sup>	0.2
EN50160 Compliance Reporting	■	■	■	■	■	■	■ (Ed4)
IEC 61000-4-30 Class A/S	■	■	■	■	■	■ (Class S Meter)	■ (Class A Ed3)
IEC 62053-22 replaces IEC 60687 0.2S compliant	■	■	■	■	■	■	■ (0.1S)
IEC 62053-23, 24 compliant for Reactive Energy accuracy	■	■	■	■	■	■	■ (0.2S)
IEC 62586-1 (new Power Quality standard)	■	■	■	■	■	■	■
IEC 60687 accuracy class compliant	■ (0.5)	■	■ (0.2)	■ (0.2)	■ (0.2)	■ (0.2)	■ (0.2)
ANSI class 10, IEC 1/10 (1A nominal, 10A max)	■	■	■	■	■	■	■
ANSI class 20, IEC 5/20 (5A nominal, 20A max)	■	■	■	■	■	■	■
Time-of-use	■	■	■	■	■	■	■
Transformer/line loss compensation	■	■	■	■	■	■	■

Some features are optional. Refer to datasheets for allowable port configurations. Products meet or exceed the accuracy requirements of the standards listed; due to form factors, not all ANSI/IEC compliance tests may apply. Some products certified by third-party laboratory.  
 © FA - Form A contact output, RO - Relay output      © This meter is 0.2S compliant at 5A nominal CT, and 0.5S compliant at 1A nominal CT

# Power Distribution Solutions

## PAC3100 Power Meter

### Basic Monitoring of Electrical Power Systems

The **PAC3100** is a powerful compact power monitoring device that is suitable for use in industrial, government and commercial applications, where basic metering and energy monitoring is required. The meter may be used as a stand alone device monitoring over 25 parameters or as part of an industrial control, building automation or global power monitoring system. Metering and monitoring applications range from simple analog volt and amp meter replacements to stand-alone sub-billing or cost allocation installations.

The PAC3100 has many features not usually found in this price class of meters. A large graphical display supports multiple languages and easy to use menus that can be used to set up the meter. The meter also has built in Modbus RTU communications via a RS485 interface. The meter comes standard with two digital inputs and outputs. One output is suitable for pulse output for export/import real and reactive energy. The other output is controllable from an outside source by way of a Modbus register.

#### Precision

- ANSI C12.16 Class1s
- Energy Measurement
  - Voltage +/- 1%
  - Current +/- 1%
  - Power Factor +/- 1%
  - Sampling Rate 64/per cycle
- Revenue Accurate
  - Sub Billing
  - Cost Allocation
- Cost Effective

#### Energy Management

- Energy Consumption
- Demand Control
- Automation Integration
- Solution for LEED® credit
- Monitors Critical Equipment
- Sub Metering

#### Reliability

- Economical Measurement
  - Commercial
  - Industrial
  - Residential
- Degree of Protection
  - Front – IP65
  - Rear – IP20
- 480V Connected Voltage
- Simple Retrofit Installation
- Integration with Existing Systems

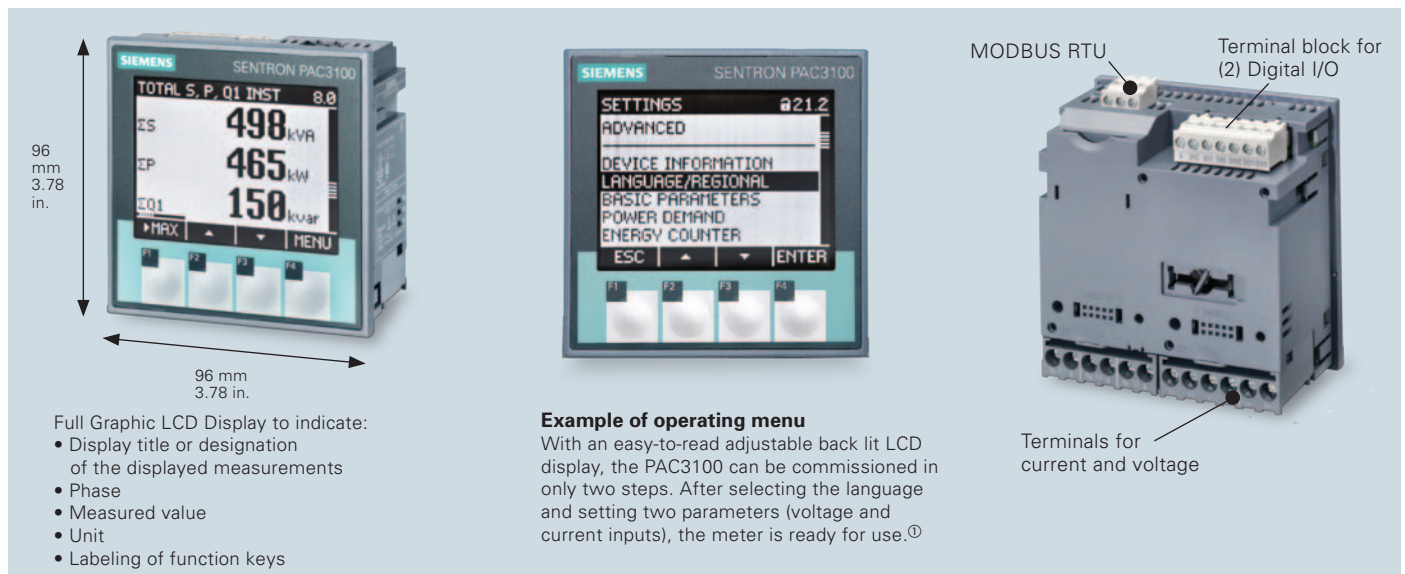

#### Order information

Product	Catalog Number
PAC3100 compression terminals AC/DC	7KM3133-0BA00-3AA0
Adapter Plate for 4700/4720 meter cutout	93-47ADAPTER
PAC32/4200 Meter DIN Rail adapter – Meter display will not be seen	7KM9900-0YA00-0AA0
PAC32/4200 Meter DIN Rail 2-adapter – Meter display will not be seen	7KM9900-0XA00-0AA0

① Languages included as standard in the meter are English, German, French, Spanish, Italian, Portuguese, Turkish, Russian and Chinese.

# Power Distribution Solutions

## PAC3200 Power Meter

### Reliable and Precise Monitoring of Electrical Power Systems

The **PAC3200** is a powerful compact power monitoring device that is suitable for use in industrial, government and commercial applications where basic metering and energy monitoring is required. The meter may be used as a stand alone device monitoring over 50 parameters or as part of an industrial control, building automation or global power monitoring system. Metering and monitoring applications range from simple analog volt and amp meter

replacements to stand-alone sub billing or cost allocation installations with multiple tariffs.

The PAC3200 provides open communications using Modbus RTU/TCP, PROFIBUS-DP, and PROFINET protocols for easy integration into any local or remote monitoring system. Simple configuration of the meter can be done from the front display.

#### Precision

- ANSI C12.20 Class 0.5s
- Energy Measurement
  - Voltage +/- .3%
  - Current +/- .2%
  - Power Factor +/- .5%
  - Sampling Rate 64/per cycle
  - Total Harmonic Distortion (THD)
- Revenue Accurate
  - Sub Billing
  - Cost Allocation
- Cost Effective

#### Energy Management

- Serves two masters via the TCP connection
- Energy Consumption
- Automation Integration
- Solution for LEED® credit
- Monitors Critical Equipment
- Modbus TCP/RTU
- Industrial Systems
  - PROFIBUS
  - PROFINET

#### Reliability

- Economical Measurement
  - Commercial
  - Industrial
  - Residential
- Degree of Protection
  - Front – IP65
  - Rear – IP20
- 600V Connected Voltage
- Simple Retrofit Installation
- Integration with Existing Systems

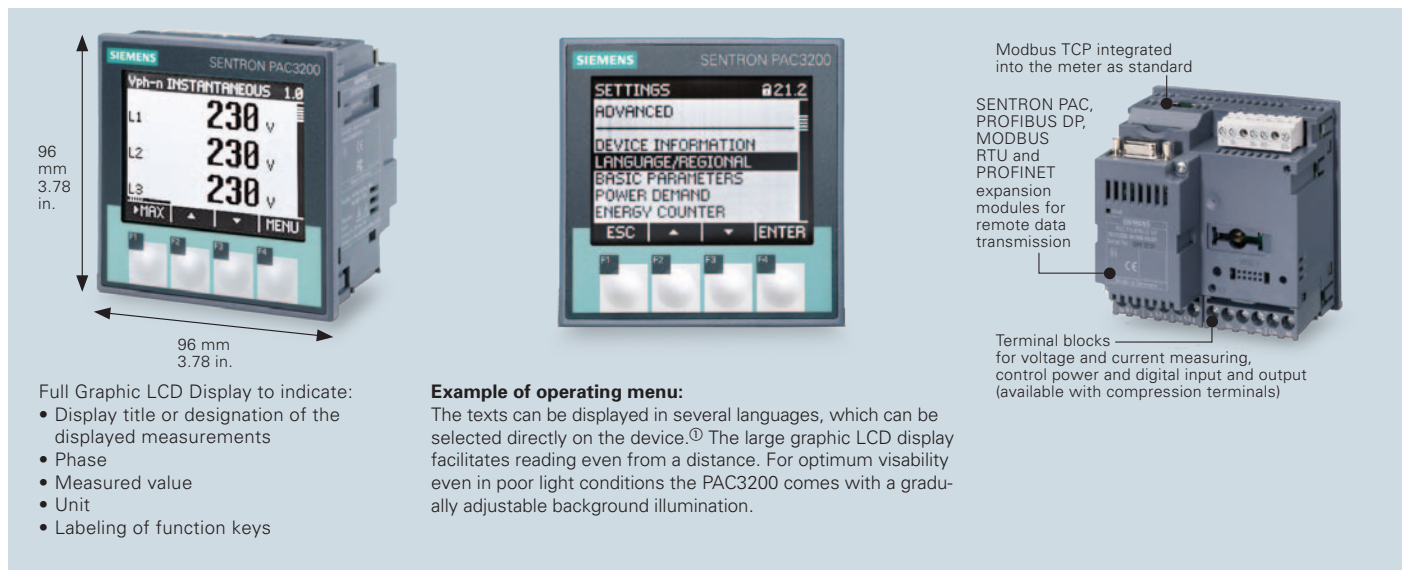

The image shows the Siemens SENTRON PAC3200 power meter. On the left, a side view shows the meter's dimensions: 96 mm (3.78 in.) in height and 96 mm (3.78 in.) in width. The front display shows 'Vph-n INSTANTANEOUS 1.0' and three phase voltage readings: L1 230 V, L2 230 V, and L3 230 V. On the right, an example of the operating menu is shown, displaying 'SETTINGS' with a value of 21.2, and options for 'ADVANCED', 'DEVICE INFORMATION', 'LANGUAGE/REGIONAL', 'BASIC PARAMETERS', 'POWER DEMAND', and 'ENERGY COUNTER'. Below the menu are four function keys labeled P1, P2, P3, and P4. To the right of the meter, a detailed view shows the terminal blocks for voltage and current measuring, control power and digital input and output (available with compression terminals). It also indicates that Modbus TCP is integrated into the meter as standard, and that expansion modules for Modbus RTU and PROFINET are available for remote data transmission.

Full Graphic LCD Display to indicate:

- Display title or designation of the displayed measurements
- Phase
- Measured value
- Unit
- Labeling of function keys

**Example of operating menu:**  
The texts can be displayed in several languages, which can be selected directly on the device.<sup>①</sup> The large graphic LCD display facilitates reading even from a distance. For optimum visibility even in poor light conditions the PAC3200 comes with a gradually adjustable background illumination.

#### Order information

Product	Catalog Number
PAC3200 compression terminals (not suitable for use with ring tongue terminals), AC/DC	7KM21120BA003AA0
PAC3200 compression terminals (not suitable for use with ring tongue terminals), DC only	7KM21111BA003AA0
PAC PROFIBUS DP expansion module	7KM93000AB010AA0
PAC PROFINET expansion module	7KM93000AE010AA0
PAC MODBUS RTU expansion module	7KM93000AM000AA0
PAC3200/4200 Meter DIN Rail adapter – Meter display will not be seen	7KM99000YA000AA0
PAC3200/4200 Meter DIN Rail 2-Tier adapter – Meter display will not be seen	7KM99000XA000AA0
Power Supply. Input: 120-230V AC / 110-300V DC Output: 24 V DC 4 Amps. DIN Rail mounted.	US2:PWRSP4A
Adapter Plate for 4700/4720 meter cutout	93-47ADAPTER

① Languages included as standard in the meter are English, German, French, Spanish, Italian, Portuguese, Turkish, Russian and Chinese.

# Power Distribution Solutions

## PAC4200 Power Meter

### Reliable and Precise Monitoring of Electrical Power Systems

The **PAC4200** is a feature packed power monitoring device that is suitable for use in industrial, government and commercial applications where basic to advanced metering, logging, and I/O is required. The meter may be used as a stand alone device monitoring over 200 parameters or as part of an industrial control, building automation or global enterprise wide monitoring system.

Advanced power quality monitoring and logging applications range from single low-voltage breaker / building metering to sub-station main feeder monitoring, sub-billing or cost allocation installations with multiple tariffs. Whether your goal

is to reduce operation cost, reduce your carbon footprint or to maintain your power assets, the PAC4200 meter should be an important part of your power monitoring system.

The PAC4200 provides open communication using the standard built-in Ethernet Modbus TCP and has the capability of communicating through Optional Modbus RTU, PROFIBUS-DP, and PROFINET protocol modules simultaneously. This allows for easy integration into any local or remote monitoring system. The gateway functionality of this device reduces installation cost by replacing other gateway devices and simplifying wiring.

#### Precision

- ANSI C12.20 Class .2s
- Energy Measurement
  - Voltage +/- .2%
  - Current +/- .2%
  - Power Factor +/- .5%
  - Sampling Rate 204/per cycle
  - Individual Harmonics up to 63rd
- Power Quality
- Revenue Accurate
  - Sub Billing
  - Cost Allocation
- Cost Effective

#### Energy Management

- Serves three masters via the TCP connection
- Energy Consumption
- Min/Max and Event Logs
  - Storage Capacity 40 days at 15 min intervals
  - Event Logging 4000 events
- Demand Control
- Automation Integration
- Modbus Gateway
- Modbus TCP/RTU
- Industrial Systems
  - PROFIBUS
  - PROFINET

#### Reliability

- Monitors Critical Equipment
- Economical Measurement
  - Commercial
  - Industrial
- Degree of Protection
  - Front – IP65
  - Rear – IP20
- 600V Connected Voltage
- Customizable Displays
- Simple Retrofit Installation
- Integration with Existing Systems
- Solution for LEED® credit

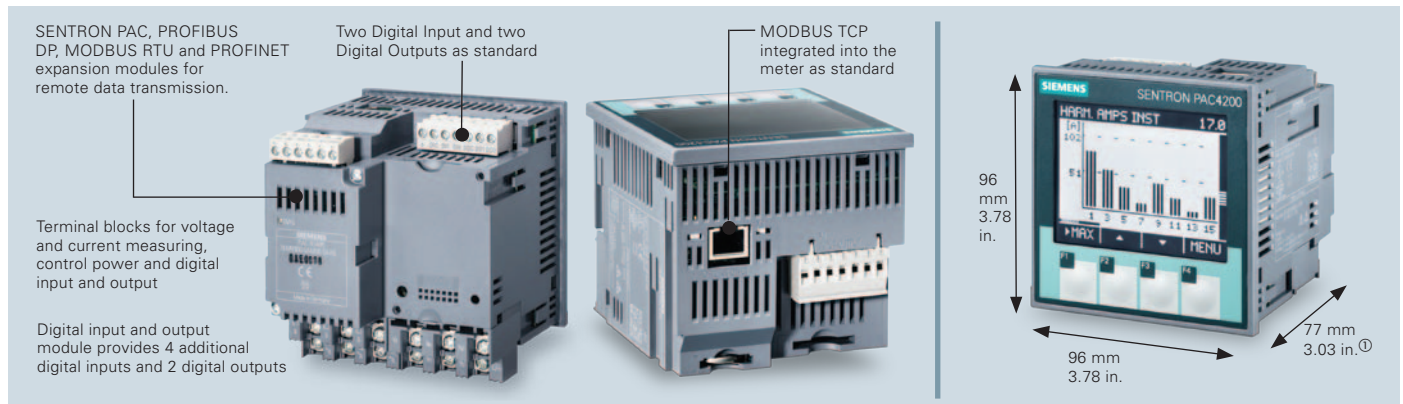

#### Order information

Product	Catalog Number
PAC4200 compression terminals (not suitable for use with ring tongue terminals), AC/DC	7KM42120BA003AA0
PAC4200 compression terminals (not suitable for use with ring tongue terminals), DC only	7KM42111BA003AA0
PAC PROFIBUS DP expansion module	7KM93000AB010AA0
PAC PROFINET expansion module	7KM93000AE010AA0
PAC I/O expansion module	7KM92000AB000AA0
PAC MODBUS RTU expansion module	7KM93000AM000AA0
PAC3200/4200 Meter DIN Rail adapter – Meter display will not be seen	7KM99000YA000AA0
PAC3200/4200 Meter DIN Rail 2-Tier adapter – Meter display will not be seen	7KM99000XA000AA0
Power Supply. Input: 120-230V AC / 110-300V DC Output: 24 V DC 4 Amps. DIN Rail mounted.	US2:PWRSP4A
Adapter Plate for 4700/4720 meter cutout	93-47ADAPTER

① 99mm, 3.90 in., with expansion module

# Power Distribution Solutions

## 9410 Web-Enabled Power Quality & Analysis Meter

### Reliable and Precise Monitoring of Electrical Power Systems

The 9410 series meters are ideally suited to local and remote monitoring of low- or high-voltage electrical installations in industrial facilities, commercial buildings, utility networks or critical power environments. Facility and operations personnel will benefit in energy-related costs while avoiding power quality conditions that can reduce equipment life and productivity.

The 9410 series meter is easy to install and use, offering integrated or remote high-visibility displays. A range of expansion modules help match features to the application and support field-upgrading of meters as required. Serial and Ethernet communication enable the meter to be used within a WinPM.Net power management system or with third-party management systems.

#### Precision

- ANSI C12.20 Class 0.2s
  - Energy Measurement
  - Voltage +/- .1%
  - Current +/- .1%
  - Power Factor +/- .5%
  - Sampling Rate 256/ per cycle
  - Individual Harmonics up to 63rd
  - Sags / Swells Detection
  - Programmable Math / Logic Function
- Revenue Accurate
  - Sub Billing
  - Cost Allocation

#### Energy Management

- Energy Consumption
- 9410 Waveform Capture
- Onboard Waveform Display Webpages
- Customizable Webpages
- Min/Max and Event Logs
- Demand Control
- Automation Integration
- Solution for LEED® credit
- Monitors Critical Equipment
- Modbus Gateway
- Modbus TCP/RTU
- Modbus Master
- Industrial Systems
- IEC 61850 Protocol

#### Reliability

- Economical Measurement
  - Commercial
  - Industrial
- Degree of Protection
  - Front – IP54, UL type 12
  - Rear – IP30
- 600V Connected Voltage
- Customizable Displays
- Email Alarms through Ethernet
- Field Addable Modules
- Simple Retrofit Installation
- Integration with Existing Systems

#### Order information

Product	Catalog Number
9410 AC Powered Panel meter with integrated color display, 1 DO, 3 DI, dual port Ethernet	US2:9410DC
9410 AC Powered DIN transducer meter packaged with remote display (includes 3m cable)	US2:9410RC
9410 AC Powered Meter without display (DIN rail mount transducer version) with 1 DO, 3 DI, dual port Ethernet	US2:9410TC
9410 DC Powered Panel meter with integrated color display, 1 DO, 3 DI, dual port Ethernet, 20Vdc-60Vdc PS	US2:9410D24VDC
9410 DC Powered DIN transducer meter packaged with remote display (includes 3m cable), 20Vdc-60Vdc PS	US2:9410R24VDC
9410 DC Powered Meter without display (DIN rail mount transducer version) with 1 DO, 3 DI, dual port Ethernet, 20Vdc-60Vdc PS	US2:9410T24VDC
9410 Panel meter with integrated color display, 1 DO, 3 DI, dual port Ethernet. Measurement Canada - Ready to be Hardware/Firmware sealable. SIEMENS Canada to work with local sealing house for actual hardware sealing	US2:9410DCAN
Accessories	Catalog Number
9410 Remote color LCD display, 96 mm x 96 mm, with 3 m cable	US2:948DISP96
9410 I/O Module with 2 relay outputs, and 6 digital inputs (wetted)	US2:948M2DO6DI
9410 I/O Module, 2 analog outputs (4 - 20 mA, 0- 10 VDC), and 4 analog inputs (4 - 20 mA, 0 - 30 VDC)	US2:948M2AO4AI
9410 Voltage and Current Sealing Kit (included with base meter)	US2:9410SK
9410 Remote display cable, 10 meters	US2:948DCAB10
9410 Remote Display Mounting Adapter kit for 4" round hole - requires 9410RC	US2:94PMIAK
9410 Replacement hardware kit for 9410 meter	US2:94PMHWK
9410 Replacement hardware kit for remote display	US2:94PMRDHWK
9410 24Vdc Meter replacement hardware kit for remote display	US2:94PMHWKDC

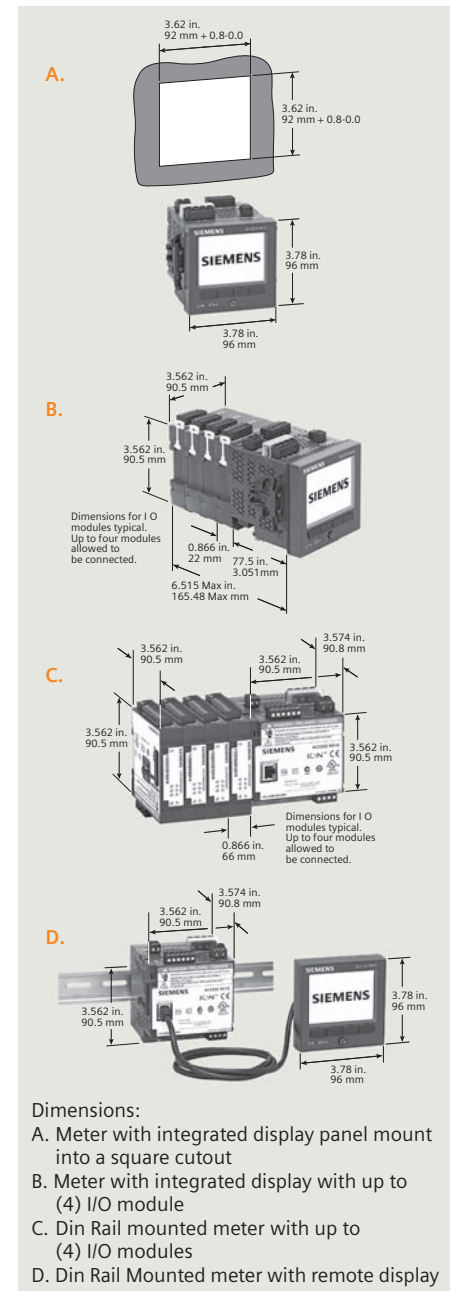

Dimensions:  
 A. Meter with integrated display panel mount into a square cutout  
 B. Meter with integrated display with up to (4) I/O module  
 C. Din Rail mounted meter with up to (4) I/O modules  
 D. Din Rail Mounted meter with remote display

# Power Distribution Solutions

## 9810 High Accuracy Advanced Power Quality and Analysis Meter

### Power Quality Meter with Web Server Technology

The Siemens 9810 series high accuracy and advanced power quality meter combines accurate; 3-phase energy and power measurement with data logging, power quality analysis, e-mail, alarming, Modbus mastering, Transient detection, Disturbance Direction Detection (DDD), Pre-Event/Post-Event Waveform capture and extensive I/O capabilities in a highly flexible and modular format. Analysis results are captured in the event log, along with a time-stamp and confidence level indicating level of certainty. The 9810 base meter includes 8 digital inputs capable of providing  $\pm 1$  millisecond time stamping and 4 digital outputs. The 9810 meters support numerous protocols including Modbus, ION, DNP3, IEC 61850, HTTP, HTTPS, DLMS, FTP, SNMP, SMTP, DPWS, RSTP, PTP, NTP/SNTP, GPS, Syslog, and DHCP protocols.

Fast sampling rates and extensive memory make this the perfect choice for critical power systems making analysis of issues possible for correction and prevention. As a data accumulator, the 9810 meter can also save money and time by simplifying wiring and networking. Information from the meter and downstream devices can be displayed on the large capacitive 7" touch display or smaller 3.5" display, on customizable web pages in reports and screens.

Applications for the 9810 meter range from critical power applications such as data centers to industrial, commercial and government power and power quality monitoring systems. The 9810 meter is offered in a number of forms from single meter enclosures integrated into Siemens switchgear, switchboard and panelboards. Place this high end power quality meter throughout the power distribution system where critical information is desired. Know what is happening in your facility and get maximum efficiency.

#### Precision

- ANSI C12.20 Class .1s
- Energy Measurement
  - Voltage +/- .1%
  - Current +/- .1%
  - Power Factor +/- .5%
  - 9810 Sampling Rate  
1024 samples per cycle
  - 9810 Individual Harmonics  
up to 63rd
  - Sags / Swells Detection
  - Programmable Math /  
Logic Function
- Revenue Accurate
  - Sub Billing
  - Cost Allocation

#### Reliability

- Economical Measurement
  - Commercial
  - Industrial
- 600V Connected Voltage
- Email Alarms
- Customizable Displays
- Password Protected
- Hardware Lockable
- Supports Copper Ethernet
- Integration with Existing Systems



#### Energy Management

- Energy Consumption
- Waveform Capture
- Transient Capture 17  $\mu$ s @ 60 Hz
- Disturbance Direction Detection (DDD)
- Customizable Webpages
- Extensive data logging, trending and forecasting  
Non-volatile on-board logging of min/max values, energy and demand, maintenance data, alarms, and any measured parameters. Trending and short-term forecasting of energy, demand, and measured parameters.
- Demand Control
- Automation Integration
- Monitors Critical Equipment
- Modbus Master / Gateway
- Supports Multiple Protocols
- Supports Multiple Master via Ethernet

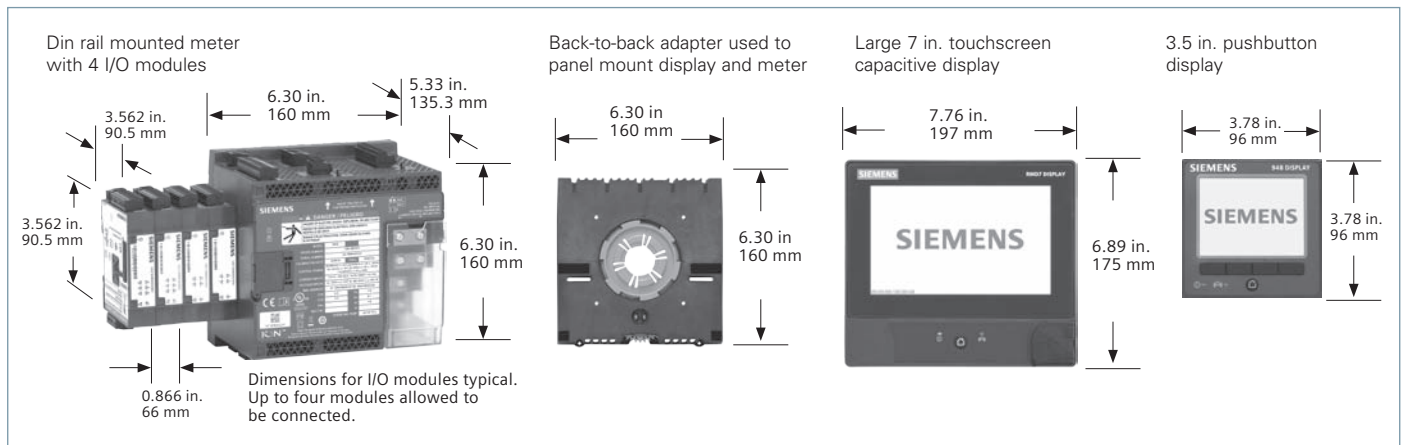



# Power Distribution Solutions

## 9810 High Accuracy Advanced Power Quality and Analysis Meter

### Order information

Product	Catalog Number
9810 with 7" display (either din rail or panel mount)	US2:9810RC
9810 without display	US2:9810TC
Accessories	Catalog Number
Large 7" display	US2:9810R7DISP
Small 3.5" display + 3M cable	US2:948DISP96
Remote display cable 10 M	US2:948DCAB10
Remote display hardware kit	US2:9810PMRDHWK
Expansion Modules	Catalog Number
I/O Module-Digital (6IN/2OUT)	US2:948M2DO6DI
I/AI Module-Analog (4IN/2OUT)	US2:948M2AO4AI
Miscellaneous	Catalog Number
9810 Hardware Kit	US2:9810PMHWK
9810 Back to Back adapter	US2:9810BBADAPTER
9810 Current Input Green Connectors Hardware Kit.	US2:9810CTHWK
9610/9510/ADR to 9810 mounting adapter	US2:9810MADAPTER

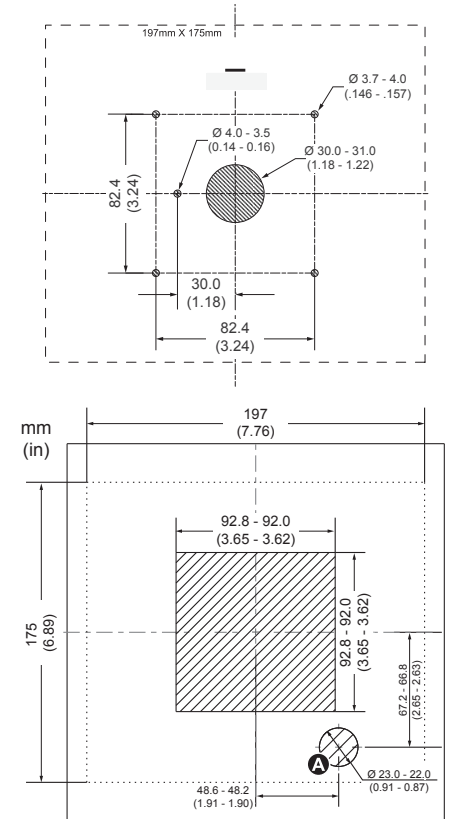

### Electrical Characteristics

Measurement accuracy	Current and voltage	Class 0.1 as per IEC 61557-12
	Active power	Class 0.1 as per IEC 61557-12
	Power factor	Class 0.5 as per IEC 61557-12
	Frequency	Class 0.02 as per IEC 61557-12
	Active energy	Class 0.1S IEC 62053-22 (In=5A) Class 0.1 IEC 61557-12, ANSI C12.20 Class 0.1
	Reactive energy	Class 0.5S IEC 62053-24
Data update rate	1/2 cycle or 1 second	
Input-voltage characteristics	Specified accuracy voltage	57 VLN/100 VLL TO 400 VLN/690 VLL
	Impedance	5MΩ per phase
	Specified accuracy frequency	42 to 69Hz (50/60Hz nominal)
	Limit range of operation -frequency	20 to 450Hz
Input-current characteristics	Rated nominal current	1A (0.1S), 5A (0.1S), 20A (0.1ANSI)
	Specified accuracy current range	Starting Current: 1mA (No Accuracy) Accurate Range: 10mA-20A
	Permissible overload	500A rms for 1s
	Impedance	0.0003Ω per phase
	Burden	0.01 VA max at 5A
Power supply	AC	90-480V AC ±10% (50/60Hz ± 10%), 90-120V AC ±10% (400Hz)
	DC	110-480V DC ±15%
	Ride-through time	100 ms (6 cycles at 60Hz) typical, 120V AC 400 ms (24 cycles at 60Hz) typical, 240V AC 1200 ms (72 cycles at 60Hz) typical, 480V AC
	Burden	Meter Only: 16.5W/38 VA max at 480V AC (50/60 Hz) Fully optioned meter: 40W/80 VA max at 480V AC (50/60 Hz)
Input/outputs	Meter Base Only	Meter Base Only 8 form A digital inputs (30V AC/60V DC) 4 form A (KY) solid state digital output (30V AC/60V, 75mA) 2 form C relay outputs (8 A at 250 V AC/ 5 A at 24 V DC)
	Optional	Digital - 6 form A digital inputs (30V AC/60V DC) 8 A at 250V AC or 5A at 24V DC) Analog - 4 analog inputs (4-20mA, 0-30V DC) +2 analog outputs (4-20mA 0-10V DC)

### Mechanical Characteristics

Weight	DIN rail mounted Model	1.5 kg
	I/O modules	0.140 kg
	7" Touchscreen display:	0.861 kg
IP degree of protection	3.5" Display:	0.300 kg
	IP 65, UL type 12: Panel mount and touchscreen display, front.	
	IP 30: Panel mount rear, DIN rail mount, I/O modules.	
Dimensions	Panel mount model: Color remote display (2 options): 197 x 175 x 27.5 mm touchscreen 96 x 96 x 27 mm pushbutton	160 x 160 x 135.3 mm
	DIN model	160 x 160 x 135.3 mm
	I/O modules	90.5 x 90.5 x 22 mm
	Touchscreen Display(s)	192 mm and 96 mm

# Power Distribution Solutions

## Enclosed Meters

### Convenience and Reliability with Siemens Meter Enclosures

The Siemens meter enclosure offering is available to order with the SENTRON PAC series meters, the ACCESS series meters, and a combination of both power meter product offerings. The enclosed meter offering provides the required energy and basic metering information needed for a typical sub-billing / cost allocation application, as well as providing a simple retrofit solution for any project.

With Safety being paramount, Siemens has designed the meter enclosure product offering with many safety and convenience features in mind. These include a single circuit breaker for both the control voltage & voltage taps to protect internal wiring and the power meters from damage and allowing a "single source" disconnect from outside power, separate CT shorting blocks for each meter, a grounding lug, and the Modbus serial communications will be terminated to one location for ease of network installation.

The Siemens meter enclosure solutions are delivered with all the required components pre-installed prior to shipment. All components will be mounted to a back plate in the enclosure and for applications above 240 volts, a CPT will be provided for control.

For low cost and simple tenant monitoring, sub-billing or industrial cost allocation, turn to Siemens metering units. Installed in rugged NEMA 1 or NEMA 12 enclosures, these metering units are ideal for:

- Property Management Firms
- Government Applications
- Universities
- Corporate Campus Facilities
- Malls
- Food Courts
- Building Retrofits



#### Features:

- Rugged design and small footprint for easy installation
- Bright, easy-to-read LCD display
- Multiple configurations
- Packaged by voltage and current ratings to accommodate any installation
- Utilizes 5A secondary current input for improved accuracy and increased compatibility

#### Benefits:

- Replace multiple utility meters with one enclosure, saves wall space
- Consolidate utility bills for sub-billing and energy management, bill tenants on actual usage
- Improve energy efficiency
- Aggregate energy purchases for reduced rates
- Improve productivity when coupled with Siemens software solutions or third party billing software

#### Catalog Logic:

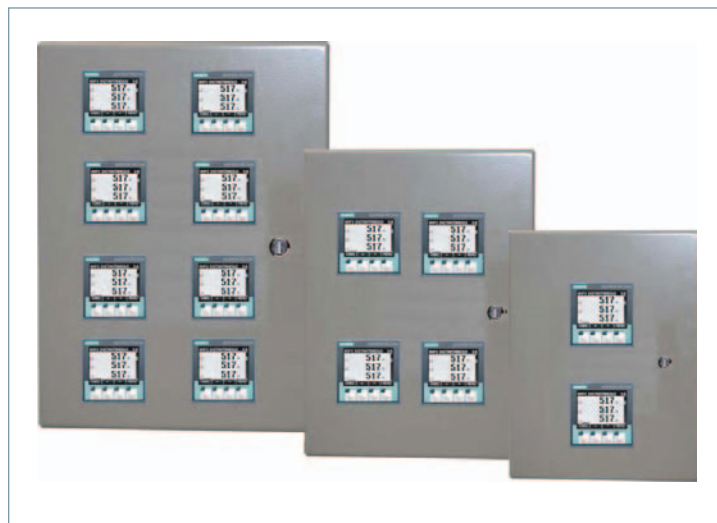
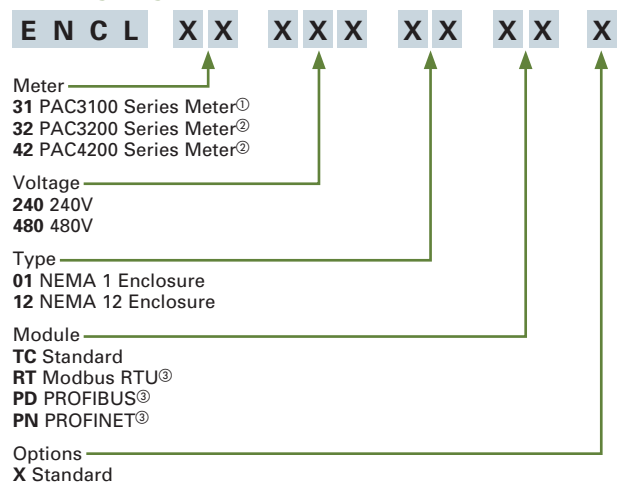

Meter Enclosure Without Meter	
Catalog Number	Description
US2:ENCL3124001TCX	PAC3100,240V, NEMA1
US2:ENCL3148012TCX	PAC3100,480V, NEMA12
US2:ENCL3224001TCX	PAC3200,240V, NEMA 1
US2:ENCL3248012TCX	PAC3200,480V, NEMA12

① PAC3100 standard is Modbus RTU.  
 ② PAC3200 and PAC4200 Standard is Modbus TCP.  
 ③ Modules not available on PAC3100.

# Power Distribution Solutions

## Branch Circuit Monitoring/ SEM3 Embedded Metering

### Space Savings, Convenience, and Reliability with Siemens Branch Circuit Monitoring



In a world where tenant square footage is a premium in commercial building designs, the area for electrical metering is being drastically reduced, and critical power is being relied upon in data centers applications, Siemens Branch Circuit Monitoring provides the solution.

The Siemens Branch Circuit Monitoring Solution utilizes the metering and monitoring technology integrated into the space saving panelboards from Siemens. When compared to the typical external wall mounted metering installations, considerable savings in space, installation costs, and data collection are realized with the Siemens Branch Circuit Monitoring Solution.

In addition, contractor labor costs for installation of sub-metering systems continues to increase. Still, building owners and property management companies must face the challenges of how to cost effectively provide tenant sub-metering in the constrained spaces.

To meet the sub-metering challenges of designers, contractors and property management companies, Siemens offers a proven cost-effective solution for Branch Circuit Monitoring/Embedded Metering. This solution combines a fully integrated metering system factory installed into the Siemens Panelboards, Switchboards, Bus Plug and remote external wall mount enclosures, which along with the required local or remote sub-billing software, provides a "Total" sub-metering system.

#### Siemens Branch Circuit Monitoring / Embedded Metering Solution

- Saves you money – A tenant billing system improves cash flow, allows immediate pass-on of electric rate increases and helps building owners control costs. Tenants are confident they are paying their fair share for energy use and are saving money through energy conservation.
- Fast, low-cost installation – The embedded Siemens solution provides a faster and lower cost installation compared to other external systems.
- Lower space requirements – The embedded panelboard construction design requires no additional wall space to provide tenant metering. Conventional metering requires an external metering enclosure and possibly a current transformer transition cabinet.
- Reliable and accurate – Many Siemens systems are already in operation in large commercial and residential buildings around the country. Their accuracy exceeds utility industry and government standards for revenue grade meters.
- LEED certification – Provides the energy monitoring and logging required to achieve additional LEED points.
- Automated billing – With automated billing services the responsibility to acquire the data, store the data and bill the tenants is removed from the property management company, thus saving manpower and time.
- Responsive service – With remote monitoring, continuous 24/7 monitoring can be done by the property management company or tenants. The service can also relay consumption changes to the owners for immediate investigation.

#### Designer and contractor benefits include:

- Much smaller footprint versus the traditional socket meter combo units
- Factory pre-wired – less installation time
- Drastically less installation wiring
- No CT installation required in the field
- All equipment fits into the standard Siemens panel design
- Additional utilities like water, air and gas can be easily integrated into the system for a comprehensive monitoring system
- Hardwire and wireless communication options
- All components factory calibrated to meet revenue metering requirements
- Additional meters can be added in the field
- UL, IEC, BTL, ANSI and CSA approved
- NY & CA State Approved Meter.
- Embedded web-server for on-site configuration and real time data view.
- Monitor 1 to 45 branch circuits.

#### Branch Circuit Monitoring applications include:

- Mixed Tenant & Retail
- Industrial Manufacturing
- Higher Ed
- Strip Malls
- Critical Power
- Government
- LEEDS buildings
- Airports

**Please Contact Your Siemens Sales Engineer for additional information regarding Branch Circuit Monitoring / Embedded Metering**

# Power Distribution Solutions

## Branch Circuit Monitoring/ SEM3 Embedded Micro Sub Metering

### Powerful embedded metering at the source of consumption!

The new Siemens Embedded Micro Metering Module (SEM3) is a modular metering solution for energy monitoring, data analysis, and sub billing applications. The flexible design allows for low, medium, and high density metering requirements to be met efficiently and economically using only a few standardized components integrated into Siemens Panelboard and Switchboard products. SEM3 is pre-engineered to integrate into new Siemens Panelboards and Switchboards but has also been designed to be implemented in OEM and retrofit applications as well.

The SEM3 provides an innovative and cost effective metering solution that can be incorporated into existing applications such as power monitoring, building automation, and sub-billing systems. SEM3 also has the flexibility to be installed as a standalone solution with real time data available from the controller's standard built-in web pages. This metering product has two levels of accuracy to meet the market's differing requirements and price points. This versatile system allows you to meter just the loads you need without the excess hardware and space requirements of traditional or competing solutions.

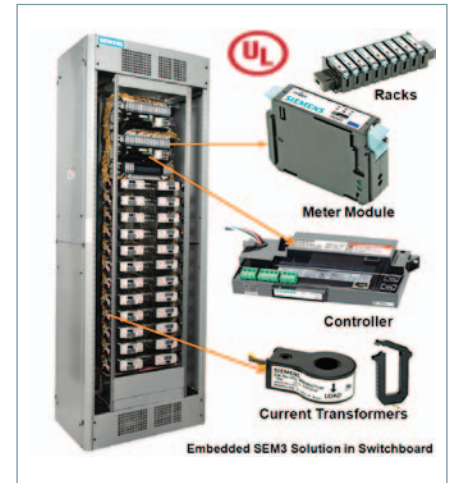

### Order Information

#### Features & Benefits:

- System designed to meter up to 45 metering points
- Easy retrofit and plug-n-play expansion features
- High metering accuracy up to 0.2%; standard 1.0%
- Installed and configured in SIEMENS engineered Panel boards, Switchboards, and Bus Plugs at SIEMENS Plants. SIEMENS ONE SOLUTION!
- Built-in HTML web pages for easy configuration & real-time data monitoring for Voltage, Current, Power, Energy, Water, and, Gas
- Modbus RTU, Modbus TCP, SNMP, NTP, BACnet IP & MSTP protocols
- Utilizes milliamp CT's reducing hardware and increasing safety
- Solid core CT's for high accuracy and split core CT's for easy retrofit.
- Emailing, Alarming, Trending, Totalizing, Event Logging & Data Logging
- Offline Configuration for improving Field and Factory engineering time
- 4 Language support includes English, German, French, and Spanish

Controller	Catalog Number	
Main Controller	US2:SEM3CONTROLLER	
<b>Meter Modules</b>		
Meter - Standard Accuracy 1% with Pulse Output	US2:SEM3PLAMETER	
Meter - High Accuracy 0.2% with Pulse Output	US2:SEM3PHAMETER	
<b>Meter Modules</b>		
Meter Rack 3 Position	US2:SEM3RACK3	
Meter Rack 6 Position	US2:SEM3RACK6	
Meter Rack 9 Position	US2:SEM3RACK9	
Meter Rack 15 Position	US2:SEM3RACK15	
Meter Rack 21 Position	US2:SEM3RACK21	
<b>Cables</b>		
Controller to Rack Cable - 6 Inch	US2:SEM3CAB6INCH	
Controller to Rack Cable - 12 Inch	US2:SEM3CAB12INCH	
Controller to Rack Cable - 24 Inch	US2:SEM3CAB24INCH	
Controller to Rack Cable - 36 Inch	US2:SEM3CAB36INCH	
Controller to Rack Cable - 5 Foot	US2:SEM3CAB5FT	
Controller to Rack Cable - 10 Foot	US2:SEM3CAB10FT	
Controller to Rack Cable - 20 Foot	US2:SEM3CAB20FT	
<b>Solid Core CT's</b>		
Solid Core CT 50:0.1	US2:SEM3SCCT50	
Solid Core CT 125:0.1	US2:SEM3SCCT125	
Solid Core CT 250:0.1	US2:SEM3SCCT250	
Solid Core CT 400:0.1	US2:SEM3SCCT400	
Solid Core CT 600:0.1	US2:SEM3SCCT600	
Solid Core CT 800:0.1	US2:SEM3SCCT800	
Solid Core CT 1200:0.1	US2:SEM3SCCT1200	
Solid Core CT 1600:0.1	US2:SEM3SCCT1600	
Solid Core CT 2000:0.1	US2:SEM3SCCT2000	
<b>Split Core CT's</b>		
Split Core CT 50:0.1	US2:4LSF0050	
Split Core CT 125:0.1	US2:4LSF0125	
Split Core CT 250:0.1	US2:4LSF0250	
Split Core CT 400:0.1	US2:4LSF0400	
Split Core CT 600:0.1	US2:4LSF0600	
Split Core CT 800:0.1	US2:4LSF0800	
Split Core CT 1200:0.1	US2:4LSF1200	
Split Core CT 1600:0.1	US2:4LSF1600	
Split Core CT 2000:0.1	US2:4LSF2000	

# Power Distribution Solutions

Embedded Micro Metering Module™

Selection

Meter Rack  
(3, 9, 15, 21)

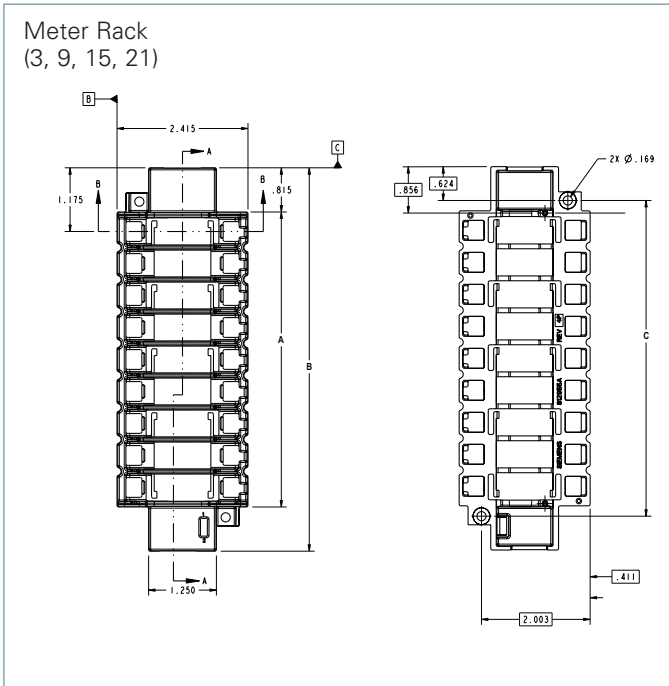

Meter Rack  
(3, 9, 15, 21)

Catalog Number	Description	Variable Dimensions (inches)		
		A	B	C
US2:SEM3RACK3	3 position rack	1.900	3.570	2.282
US2:SEM3RACK6	6 position rack	3.670	5.340	4.050
US2:SEM3RACK9	9 position rack	5.440	7.070	5.822
US2:SEM3RACK15	15 position rack	8.980	10.610	9.362
US2:SEM3RACK21	21 position rack	12.520	14.150	12.902

Controller Dimensions

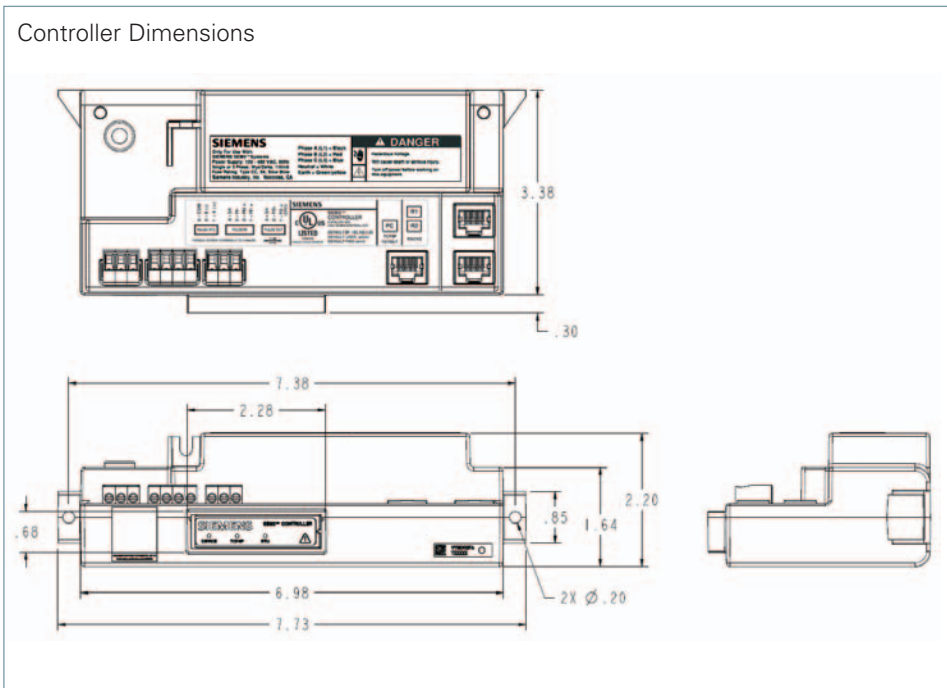

Controller

Catalog no.
US2:SEM3CONTROLLER

# Power Distribution Solutions

## Embedded Micro Metering Module™

Selection

### Current Transformer – Solid Core

Description	Catalog Number	Dimensions (Inches)						
		A	B	C	D	E	F	G
Solid Core CT 50:0.1	US2:SEM3SCCT50	1.40	0.38	0.20	0.92	2.12	0.74	0.37
Solid Core CT 125:0.1	US2:SEM3SCCT125	1.40	0.66	0.20	0.92	2.16	0.74	0.37
Solid Core CT 250:0.1	US2:SEM3SCCT250	1.90	0.93	0.20	0.92	2.75	0.78	0.39
Solid Core CT 400:0.1	US2:SEM3SCCT400	2.62	1.60	0.20	0.92	3.62	0.78	0.39
Solid Core CT 600:0.1	US2:SEM3SCCT600	3.74	2.30	0.24	0.92	4.66	0.78	0.39
Solid Core CT 800:0.1	US2:SEM3SCCT800	4.05	2.60	0.24	0.92	5.05	0.98	0.49
Solid Core CT 1200:0.1	US2:SEM3SCCT1200	4.56	2.80	0.24	0.92	5.57	0.98	0.49
Solid Core CT 1600:0.1	US2:SEM3SCCT1600	6.00	4.25	0.28	1.07	7.15	1.05	0.50
Solid Core CT 2000:0.1	US2:SEM3SCCT2000	6.00	4.25	0.28	1.07	7.15	1.05	0.50

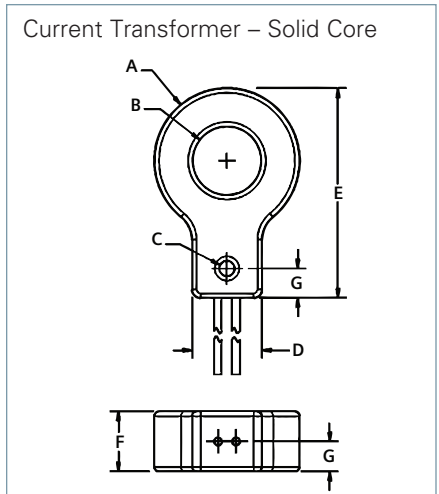

### Current Transformer – Split Core

Description	Catalog Number	A	B	C	D	E	F
50A Split Core CT	US2:4LSF0050	0.50	0.58	2.62	2.49	0.85	0.97
125A Split Core CT	US2:4LSF0125	0.75	0.76	2.59	2.43	0.83	0.94
250A Split Core CT	US2:4LSF0250	1.02	1.01	3.29	2.90	0.95	1.14
400A Split Core CT	US2:4LSF0400	1.50	1.52	3.78	3.67	0.93	1.12
600A Split Core CT	US2:4LSF0600	2.14	2.15	4.69	4.29	1.07	1.15
800A Split Core CT	US2:4LSF0800	3.01	3.15	5.56	5.28	1.07	1.15
1200A Split Core CT	US2:4LSF1200	3.05	3.24	5.94	6.28	1.06	1.47
1600A Split Core CT	US2:4LSF1600	4.51	4.60	7.72	7.28	1.06	1.47
2000A Split Core CT	US2:4LSF2000	4.51	4.60	7.72	7.28	1.06	1.47

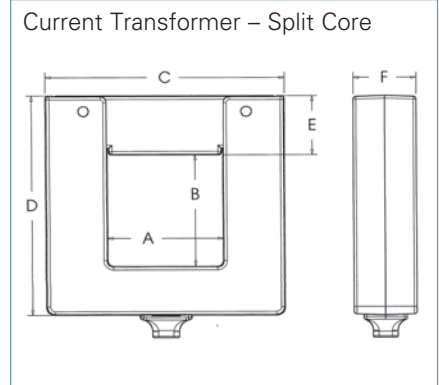

### Meter Module

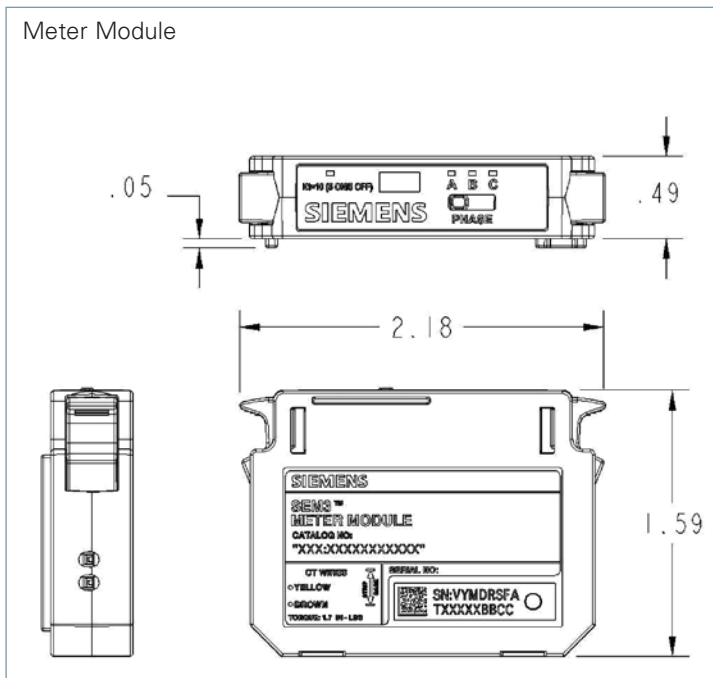

### Meter Module

Description	Catalog No.
Meter - Standard Accuracy 1% with Pulse Output	US2:SEM3PLAMETER
Meter - High Accuracy 0.2% with Pulse Output	US2:SEM3PHAMETER

## SEM3 System configured in Panelboards

The Siemens SEM3 system can be configured for factory installation in branch circuit monitoring applications using the Siemens COMPAS configuration tool. This option can lower the installation time of the system for the installer while providing a factory warranted solution.

The SEM3 system can be factory installed in unit space in type P2, P4, & P5 Siemens panel boards and SB1, SB2, & SB3 type Siemens switchboards. Please note P1 and P3 configurations are not available at this time and the amount of unit space needed varies depending upon the application. Please note that lead time adders will apply and may vary depending upon the configuration of the system.

## SEM3 for use in Siemens Panelboards

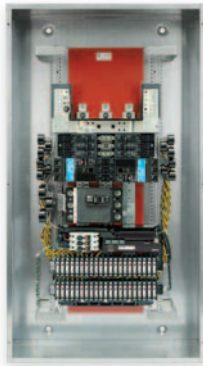

### Type P2: Enclosure

- Available in a NEMA 1, 3R, or 12 rated enclosure.
- Minimum width & depth: 24" width x 5.75" depth
- Height: Up to 74" depending on branch breaker selection
  - Addition of monitoring on some mains (primary and subfeed) may require additional box length. In these cases the box will be increased to the next size available as a standard design.
  - In cases where enclosure size is increased all multi-section panels will be increased to match the largest section.



### Controller

SEM3 controller is mounted in unit space opposite of the feed location specified in COMPAS (i.e., bottom mount for top feed) and will require 3" of unit space. Each controller will be powered by direct tap connection to the panel section bus. Each controller can monitor up to 45 circuits. Applications that require monitoring more than 45 circuits will require additional controllers.



### Current Transformers (CTs)

Five sizes of CTs are available for use in the P2 panel: 50, 125, 250, 400 & 600 amp. All CTs are pre-mounted to a support bracket that attaches to the base rail of the interior of the panel board. Each bracket supports a maximum of 3 CTs and is designed for the breaker selected (brackets are not interchangeable between breaker frames). Each CT will be attached to a data module that is placed in the meter racks.



### Meter Racks

Each meter rack requires 3" of unit space. All meter racks will be installed next to the SEM3 controller in unit space. The COMPAS configuration tool will select the appropriate meter rack configuration according to the user's application and will use the 21 space meter rack as a default option where possible. Only one meter rack (regardless of number of positions) can be installed in 3" of unit space.

**NOTE:** Monitoring of 45 circuits will require 9" of unit space: two 21 position racks and one 3 position rack

## SEM3 System configured in Distribution Panels and Switchboards

The information below pertains to panelboard types P4, P5 and switchboard types SB2, and SB3. Please note SEM3 is not available for P3 panelboards or SB1 switchboards. SEM3 is available in NEMA type 1, 3R, and 12 enclosures. SEM3 specifics to P4, P4, SB2, and SB3 are:

### SEM3 for use in Siemens Switchboards

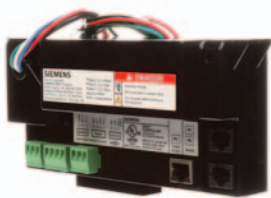

#### Controller

SEM3 controller is mounted in unit space. For P4 and P5 panels it will be mounted opposite of the feed location specified in COMPAS (i.e., bottom mount for top feed). The controller will require 3.75" of unit space in P4/5 and SB2/3. Each controller will be powered by direct tap connection to the section bus and can monitor up to 45 circuits. Applications that require monitoring more than 45 circuits will require additional controllers. For multi-section applications each controller will only be connected to meter racks in the same section as the controller.



#### Current Transformers (CTs)

Six sizes of CTs are available for use in P4/5 & SB2/3 applications: 50, 125, 250, 400, 600, and 1200 amp. All CTs are pre-mounted to a support bracket that attaches to the interior. Each bracket supports a maximum of 3 CTs and is designed for the breaker selected (brackets are not interchangeable between breaker frames). Each CT will be attached to a data module that is placed in the meter racks.



#### Meter Racks

Each meter rack requires 3.75" of unit space. All meter racks will be installed next to the SEM3 controller in unit space. The COMPAS configuration tool will select the appropriate meter rack configuration according to the user's application and will use the 21 space meter rack as a default option where possible. Only one meter rack (regardless of number of positions) can be installed in 3.75" of unit space. For multi-section applications each rack will only be connected to data modules from CTs in that section. Racks will not be setup to monitor CTs from adjacent sections.

**NOTE:** Monitoring of 45 circuits will require 9" of unit space: two 21 position racks and one 3 position rack

#### Other Considerations

**Configuration:** Data modules from CTs monitoring a circuit breaker must be mounted adjacent to one another in the meter rack. Any field changes to the factory configuration must take this into account.

**Start-up & Commissioning:** Siemens can provide these services. Contact your local SIEMENS PDS Power Solutions Business Developer for more details.

**Billing Services for sub billing applications:** Billing services are available. Contact your local SIEMENS PDS Power Solutions Business Developer for more details.



## P2 Devices Enclosure sizes

### Example P2 Panel with SEM3 Type 1 Enclosure (24" Wide x 5.75" Deep)

Enclosure heights are in 6" increments from 26" thru 74".  
Enclosure heights: 26", 32", 38", 44", 50", 56", 62", 68", 74"

The COMPAS configuration tool can provide actual dimensions based on the configuration.  
Example below is largest standard P2 enclosure for factory assembled panel with all small (1") branch breakers installed.

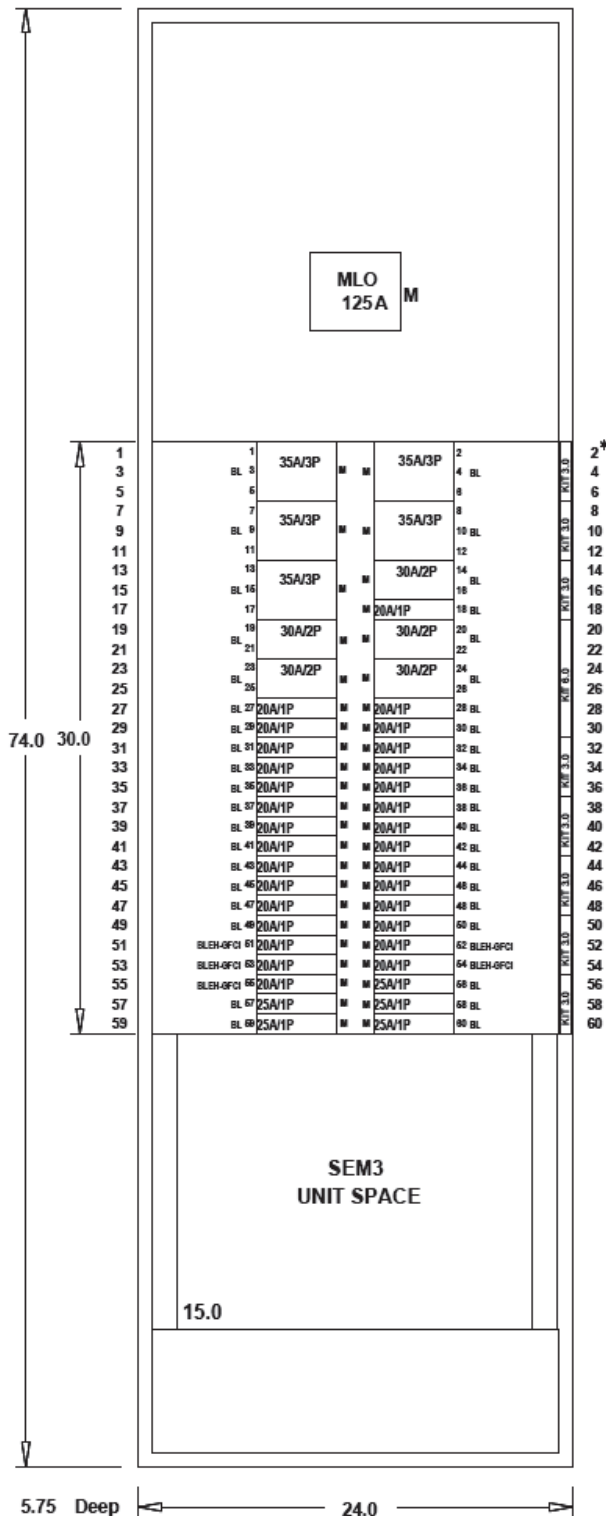

← 24" std. width →

**Main Breaker / Main Lug space varies based on selected options**

Unit space varies based on selected options

**Note:** All circuits do not have to be monitored by SEM3 - user can select any circuits in this space to be monitored.

Based on smallest branch breakers and a 3-phase main being monitored. There is a maximum of 63 circuits that can be monitored with the configuration shown. Some selections of main breakers and other subfeed options could limit this further.

In this situation there is 30" of unit space available - so 60 branch circuits could be monitored. If monitoring the main three additional circuits could be monitored with a total of 63 circuits.

This requires two controllers and three 21 position racks using 15" of unit space. - see below -

**SEM3 space varies by number of circuits monitored - this uses unit space.**

- == > 6" of space for up to 21 circuits monitored one controller and one 21-pos rack
- == > 9" of space for up to 42 circuits monitored one controller and two 21-pos racks
- == > 12" of space for up to 45 circuits monitored one controller and two 21-pos racks plus one 3-pos rack
- == > 15" of space for up to 63 circuits monitored two controllers and three 21-pos racks

**Note:** If subfeed space is needed - it will take away from available unit space.

## P4 and P5 Devices Enclosure sizes

### Example P4 and P5 Panel with SEM3 Type 1 Enclosure P4 = (32" Wide x 10" Deep) P5 = (38" or 46" Wide x 10" Deep)

Enclosure heights are in 15" increments from 60" thru 90".  
Enclosure heights: 60", 75", 90" (there are optional depths also)

The COMPAS configuration tool can provide actual dimensions based on the configuration. Example below is largest standard P4 enclosure for factory assembled panel - unit space is in 3.75" increments - up to 6 circuits can occupy each 3.75" of unit space.

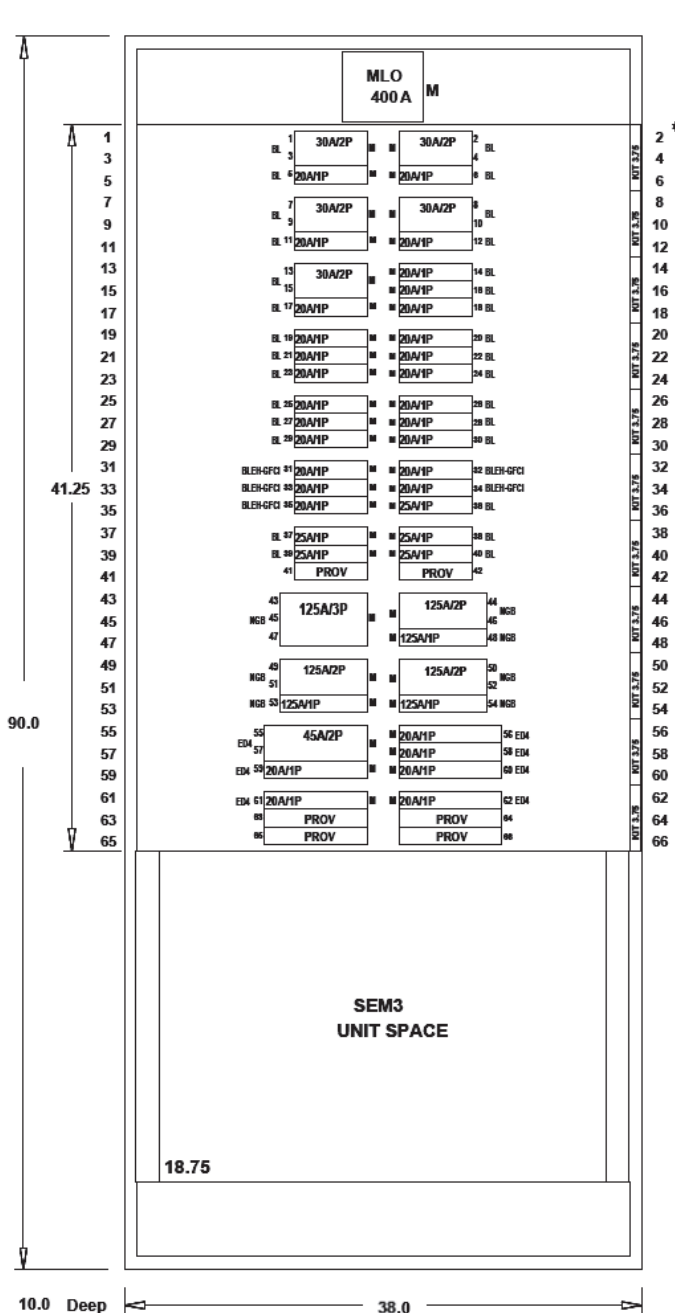

← 32" std. width for P4 →

**Main Breaker / Main Lug space varies based on selected options**

**Unit space varies based on selected options**

**Note:** All circuits do not have to be monitored by SEM3 - user can select any circuits in this space to be monitored.

Based on smallest branch breakers and a 3-phase main being monitored. There is a maximum of 63 circuits that can be monitored with the configuration shown. Some selections of main breakers and other subfeed options could limit this further.

In this situation there is 37.5" of unit space available - so 60 branch circuits could be monitored.  
If monitoring the main three additional circuits could be monitored with a total of 63 circuits.

This requires two controllers and three 21 position racks using 18.75" of unit space.  
- see below -

**SEM3 space varies by number of circuits monitored - this uses unit space.**

- == > 7.5" of space for up to 21 circuits monitored one controller and one 21-pos rack
- == > 11.25" of space for up to 42 circuits monitored one controller and two 21-pos racks
- == > 15" of space for up to 45 circuits monitored one controller and two 21-pos racks plus one 3-pos rack
- == > 18.75" of space for up to 63 circuits monitored two controllers and three 21-pos racks

**Note:** If subfeed space is needed - it will take away from available unit space.

# Power Distribution Solutions

## Enclosures for External Applications

Selection

### Standard Enclosures for External Applications

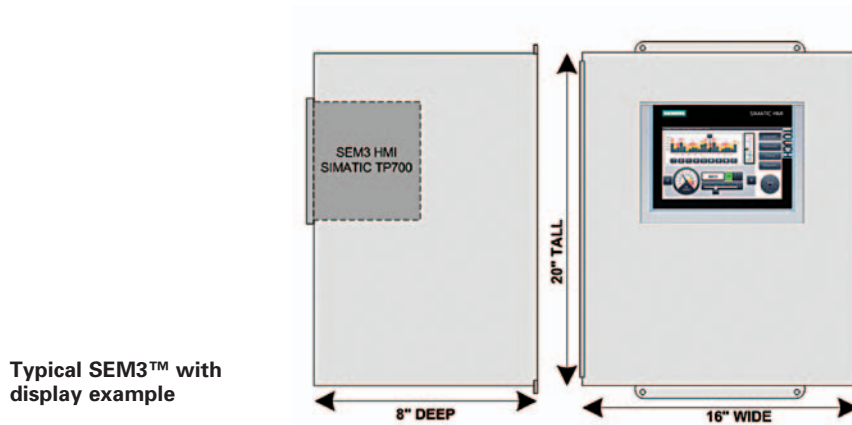

Typical SEM3™ with display example

The SEM3 standalone enclosure is ideal for retrofit/external wall mount applications, as it requires minimal modification of existing systems while gaining full functionality of the SEM3 branch circuit monitoring solution. Installation of the required milliamp current transformers (CT) is minimized by utilizing the Siemens Split Core CTs ranging from 50 to 2000 Amps. See "Split Core CT" section. SEM3 standard enclosures are available with NEMA 1, 4 and 12 ratings. The

SEM3 meter enclosure is shipped with all the required components installed. The control voltage is wired to a fusible disconnect switch to protect the system and to provide a disconnect from outside power to the meter. SEM3 Solid Core CTs are self shorting, not requiring a shorting block in the enclosure/panel. Shorting blocks are recommended for SEM3 Split Core CT's installed in an enclosure/panel. The enclosure has a ground lug for equipment grounding. When the

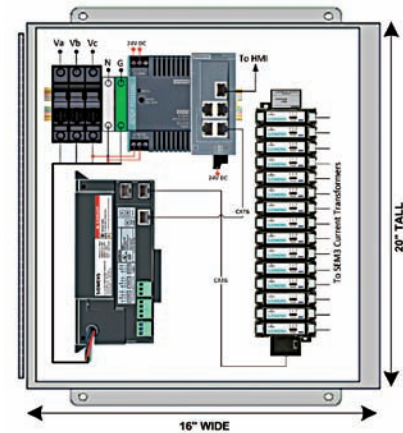

control voltage is greater than 480 volts, a CPT is provided between the disconnect switch and SEM3 controller. The enclosure is pre-drilled to make mounting quick and easy. The standard enclosure comes with the controller, power supply, disconnect, meter racks, communication cables, and shorting blocks. Meter modules and CTs are added separately. As mentioned previously, the display is available as an option.

#### No Display Standard Enclosure for External Application – HMI, SEM3 Meter Modules, and CT's are not included

Description	Catalog Numbers
SEM3 3M ENCL Type 1 16T x 12W X 6D	US2:SEM303ENCL1
SEM3 3M ENCL Type 12 16T x 12W X 6D	US2:SEM303ENCL12
SEM3 3M ENCL Type 4 16T x 12W X 6D	US2:SEM303ENCL4
SEM3 9M ENCL Type 1 16DT x 12W X 6D	US2:SEM309ENCL1
SEM3 9M ENCL Type 12W 16DT x 12W X 6D	US2:SEM309ENCL12
SEM3 9M ENCL Type 4 16DT x 12W X 6D	US2:SEM309ENCL4
SEM3 15M ENCL Type 1 16DT x 12W X 6D	US2:SEM315ENCL1
SEM3 15M ENCL Type 12W 16DT x 12W X 6D	US2:SEM315ENCL12
SEM3 15M ENCL Type 4 16DT x 12W X 6D	US2:SEM315ENCL4
SEM3 18M ENCL Type 1 20T x 12W x 6D	US2:SEM318ENCL1
SEM3 18M ENCL Type 12W 20T x 12W x 6D	US2:SEM318ENCL12
SEM3 18M ENCL Type 4 20T x 12W x 6D	US2:SEM318ENCL4
SEM3 21M ENCL Type 1 20T x 12W x 6D	US2:SEM321ENCL1
SEM3 21M ENCL Type 12W 20T x 12W x 6D	US2:SEM321ENCL12
SEM3 21M ENCL Type 4 20T x 12W x 6D	US2:SEM321ENCL4
SEM3 30M ENCL Type 1 20T x 16W x 6.62D	US2:SEM330ENCL1
SEM3 30M ENCL Type 12W 20T x 16W x 6.62D	US2:SEM330ENCL12
SEM3 30M ENCL Type 4 20T x 16W x 6.62D	US2:SEM330ENCL4
SEM3 42M ENCL Type 1 20T x 16W x 6.62D	US2:SEM342ENCL1
SEM3 42M ENCL Type 12W 20T x 16W x 6.62D	US2:SEM342ENCL12
SEM3 42M ENCL Type 4 20T x 16W x 6.62D	US2:SEM342ENCL4
SEM3 45M ENCL Type 1 20T x 16W x 6.62D	US2:SEM345ENCL1
SEM3 45M ENCL Type 12W 20T x 16W x 6.62D	US2:SEM345ENCL12
SEM3 45M ENCL Type 4 20T x 16W x 6.62D	US2:SEM345ENCL4

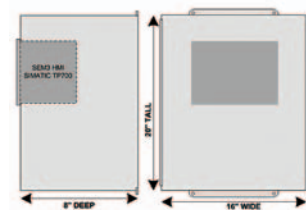

SEM3 Enclosure without display

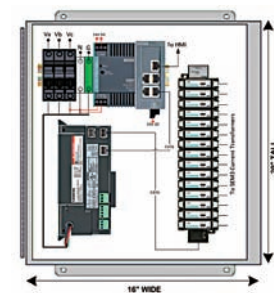

SEM3 Enclosure without meter modules installed

# Power Distribution Solutions

## Standard Enclosure with HMI Display & Switch for External Application – SEM3 Meter Modules, and CT's are not included

Description	Catalog Numbers
SEM3 3M w/display/switch 16 x 16 x 6.5	US2:SEM303ENCL1DS
SEM3 3M w/display 16 x 16 x 6.5	US2:SEM303ENCL1D
SEM3 9M w/display/switch 16 x 16 x 6.5	US2:SEM309ENCL1DS
SEM3 9M w/display 16 x 16 x 6.5	US2:SEM309ENCL1D
SEM3 15M w/display/switch 20 x 16 x 8	US2:SEM315ENCL1DS
SEM3 15M w/display 20 x 16 x 8	US2:SEM315ENCL1D
SEM3 18M w/display/switch 20 x 16 x 8	US2:SEM318ENCL1DS
SEM3 18M w/display 20 x 16 x 8	US2:SEM318ENCL1D
SEM3 21M w/display/switch 20 x 16 x 8	US2:SEM321ENCL1DS
SEM3 21M w/display 20 x 16 x 8	US2:SEM321ENCL1D
SEM3 30M w/display/switch 20 x 20 x 8	US2:SEM330ENCL1DS
SEM3 30M w/display 20 x 20 x 8	US2:SEM3301ENCL1D
SEM3 42M w/display/switch 20 x 20 x 8	US2:SEM342ENCL1DS
SEM3 42M w/display 20 x 20 x 8	US2:SEM342ENCL1D
SEM3 45M w/display/switch 20 x 20 x 8	US2:SEM345ENCL1DS
SEM3 45M w/display 20 x 20 x 8	US2:SEM345ENCL1D

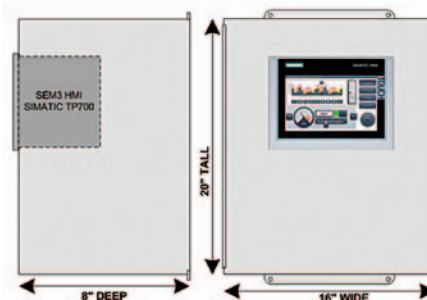

## Remote Touch Display Enclosure Package - No SEM3 parts included

Description	Catalog Numbers
SEM3 ENCL 7" Touch Display 24 VDC/1.3 Amp Power Supply	US2:SEM3TP7SEN
SEM3 ENCL 7" Touch Display 24 VDC/1.3 Amp PS UL Listed	US2:SEM3TP7SENU
SEM3 ENCL 7" Touch Display 24 VDC/1.3 Amp PS + 8 Port Switch	US2:SEM3TP7AEN
SEM3 ENCL 7" Touch Display 24 VDC/1.3 Amp PS + 8 Port Switch UL Listed	US2:SEM3TP7AENUL
SEM3 ENCL 9" Touch Display 24 VDC/1.3 Amp Power Supply	US2:SEM3TP9SEN
SEM3 ENCL 9" Touch Display 24 VDC/1.3 Amp PS UL Listed	US2:SEM3TP9SENU
SEM3 ENCL 9" Touch Display 24 VDC/1.3 Amp PS + 8 Port Switch	US2:SEM3TP9AEN
SEM3 ENCL 9" Touch Display 24 VDC/1.3 Amp PS + 8 Port Switch UL Listed	US2:SEM3TP9AENUL
SEM3 ENCL 12" Touch Display 24 VDC/1.3 Amp Power Supply	US2:SEM3TP12SEN
SEM3 ENCL 12" Touch Display 24 VDC/1.3 Amp PS UL Listed	US2:SEM3TP12SENU
SEM3 ENCL 12" Touch Display 24 VDC/1.3 Amp PS + 8 Port Switch	US2:SEM3TP12AEN
SEM3 ENCL 12" Touch Display 24 VDC/1.3 Amp PS + 8 Port Switch UL Listed	US2:SEM3TP12AENUL



## Optional Loose Remote Touch Display and Power Supply

Description	Catalog Numbers
SEM3 7" TD 100-240VAC + SITOP PS 24VDC	US2:SEM3TOUCHP7
SEM3 9" TD 100-240VAC + SITOP PS 24VDC	US2:SEM3TOUCHP9
SEM3 12" TD 100-240VAC + SITOP PS 24VDC	US2:SEM3TOUCHP12
SEM3 15" TD 100-240VAC + SITOP PS 24VDC	US2:SEM3TOUCHP15
SEM3 19" TD 100-240VAC + SITOP PS 24VDC	US2:SEM3TOUCHP19



# Power Distribution Solutions

## MD Series Power Meter

### MD BM and MD BMD Model Power Meters

Siemens Industry's MD BM and MD BMD Model Power Meters are sub metering devices designed to provide real time, accurate electricity metering to enable proper control over energy costs. The meter can capture kWh/kW energy and demand data, as well as virtually all relevant energy parameters for diagnostics and monitoring on three-phase or single-phase circuit installations. The meters' flexibility, size, and ease-of-use make them ideal tools for gathering detailed consumption information in commercial, industrial, governmental, and retail environments. The meters use direct connections to each phase of the voltage and various interchangeable current transformer (CT) options such as split-core CTs or flexible Rogowski Coils (for large loads or large cables and buss bars) to monitor current on each phase. All of Siemens' current transformers are internally shunted for intrinsically safe operation on energized conductors.

The power meters make over 75 total electrical measurements which are derived from the voltage and current inputs. Electrical load diagnostic parameters such as power factor and line frequency are captured in addition to energy and demand values. The Siemens MD BM and MD BMD Power Meters require no external power and the power supplies can accommodate service voltages ranging from 80 to 600V (phase-to-phase). The simple installation is accomplished by connecting the color-coded voltage leads and clearly labeled CTs. A three-LED indicator display confirms proper CT-to-phase installation. The meters automatically adjust for CT orientation—greatly reducing set-up time and all but eliminating installation errors.



Product Description	Catalog Number
MD Meter BACnet-Modbus	US2:MDBM
MD Meter Modbus-BACnet IP	US2:MDBMIP
MD Meter BACnet-Modbus w/display	US2:MDBMD
MD Meter Modbus-BACnet IP w/display	US2:MDBMIPD
Mini SplitCore 0.4 Opening 50A	US2:SCTHSC0050U
Mini SplitCore 0.4 Opening 100A	US2:SCTHMC0100U
Mini SplitCore 0.4 Opening 200A	US2:SCTHMC0200U
Small SplitCore 0.75 Opening 50A	US2:SCTSCS0050U
Small SplitCore 0.75 Opening 100A	US2:SCTSCS0100U
Medium SplitCore 1.25 Opening 100A	US2:SCTSCM0100U
Medium SplitCore 1.25 Opening 200A	US2:SCTSCM0200U
Medium SplitCore 1.25 Opening 400A	US2:SCTSCM0400U
Medium SplitCore 1.25 Opening 600A	US2:SCTSCM0600U
Large SplitCore 2.00 Opening 600A	US2:SCTSCL0600U
Large SplitCore 2.00 Opening 1000A	US2:SCTSCL1000U
Rogowski Coil Current Transformer, 16" (40 cm); 4.5" (11.5 cm) opening; 4000A	US2:SCTR161310U
Rogowski Coil Current Transformer, 24" (60 cm); 7.0" (18 cm) opening; 4000A	US2:SCTR241310U
Rogowski Coil Current Transformer, 36" (90 cm); 10.8 (28 cm) opening; 4000A	US2:SCTR361310U

# Power Distribution Solutions

## Low-voltage Current Transformers

Comprehensive metering grade CT offering split-core, flexible and solid core designs

### Split core – Rectangular Window

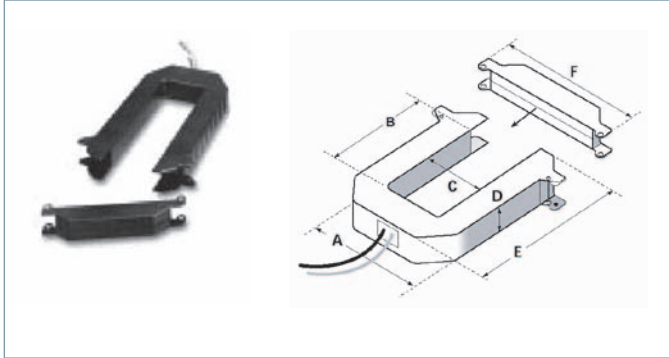

200A – 300A	400A – 800A	1000A – 1200A
A = 3.75" (95mm)	A = 4.90" (124mm)	A = 4.90" (124mm)
B = 1.51" (38mm)	B = 2.89" (73mm)	B = 5.50" (140mm)
C = 1.25" (32mm)	C = 2.45" (62mm)	C = 2.45" (62mm)
D = 1.13" (29mm)	D = 1.13" (29mm)	D = 1.13" (29mm)
E = 4.20" (107mm)	E = 5.57" (141mm)	E = 8.13" (207mm)
F = 4.75" (121mm)	F = 5.91" (150mm)	F = 5.92" (150mm)

Siemens Instrument Grade Current Transformers (CT) have a split-core construction and provide a safe 5A secondary output. These split-core current transformers allow for easy installation, retrofit, and service. CT's come with 4' leads (18 gauge). Use on low-voltage applications of 600V or less.

**Accuracy 0.5%.**

Amps	Window (C x B)	Catalog Number
200A	1.25"x1.51"	PDS-CTSC-021
300A	1.25"x1.51"	PDS-CTSC-031
400A	2.45"x2.89"	PDS-CTSC-042
600A	2.45"x2.89"	PDS-CTSC-062
800A	2.45"x2.89"	PDS-CTSC-083
1000A	2.45"x5.50"	PDS-CTSC-013
1200A	2.45"x5.50"	PDS-CTSC-123
1600A	2.45"x5.50"	PDS-CTSC-163
2000A	2.45"x5.50"	PDS-CTSC-200
3000A	2.75"x6.625"	PDS-CTSC-03R

### Split-core – Round Window

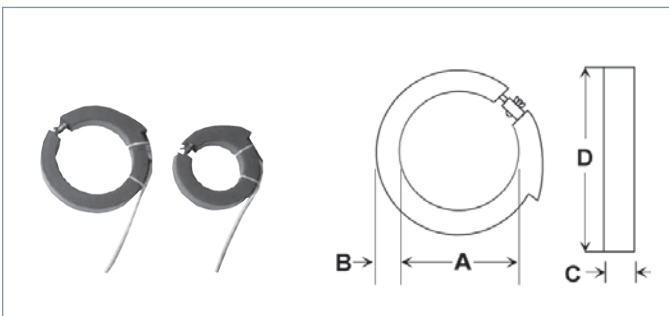

200A – 1200A	3000A – 4000A
A = 4.00"	A = 6.00"
B = 1.25"	B = 1.25"
C = 1.50"	C = 1.50"
D = 6.50"	D = 8.50"

Split-core round rubber insulated flexible CT's with 12' heavy duty leads (18 AWG) and 5A secondary output for use on low-voltage applications of 600V.

**Accuracy is 4% for 200/400A, 3% for 400A, and 2% for 600A and above.**

Amps	Window (A)	Catalog Number
200A	4.00"	PDS-CTHC-024
300A	4.00"	PDS-CTHC-034
400A	4.00"	PDS-CTHC-044
600A	4.00"	PDS-CTHC-064
800A	4.00"	PDS-CTHC-084
1200A	4.00"	PDS-CTSC-123
2000A	6.00"	PDS-CTHC-206
3000A	6.00"	PDS-CTHC-306
4000A	6.00"	PDS-CTHC-406

# Power Distribution Solutions

## Low-voltage Current Transformers

### Comprehensive metering grade CT offering split-core, flexible and solid core designs

#### Solid-core – Round with Round Window

The small size solid core Current Transformer (CT) are designed for tight locations and new installations providing a safe 5 amp secondary for use on voltage applications of 600V or less.

**Accuracy is 0.3%.**

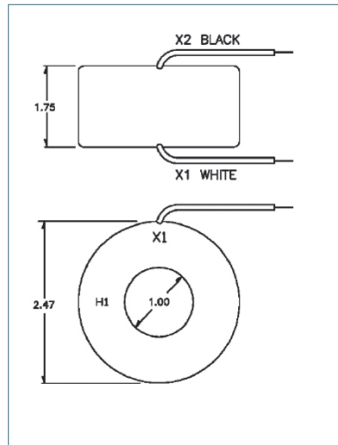

Solid core – Round metering grade, 600V		
Catalog Number	Primary	Size
SMU-CT-011	100A	1.75" x 2.47", 1" Window
SMU-CT-021	200A	1.75" x 2.47", 1" Window
SMU-CT-025	250A	1.75" x 2.47", 1" Window
SMU-CT-031	300A	1.75" x 2.47", 1" Window
SMU-CT-041	400A	1.1" x 3.56", 1.56" Window
SMU-CT-061	600A	1.1" x 3.56", 1.56" Window
SMU-CT-081	800A	1.1" x 3.56", 1.56" Window
SMU-CT-123	1000A	1.1" x 3.56", 1.56" Window
SMU-CT-02R	2000A	1.15" x 5.73", 3.25" Window

#### Solid-core – Square with Round Window

Siemens Instrument Grade Current Transformers (CT) are designed as solid-core construction and provide a safe 5A secondary output. Solid-core CT's come with terminals for attaching leads. Use on low-voltage applications of 600V or less.

**Accuracy is 0.3%.**

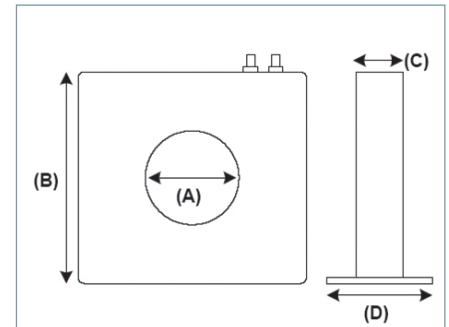

Amps	Dimension (A x B x C x D)	Catalog Number
200:5	1.25" x 4.88" x 2.19" x 4.68"	PDS-CTRC-021
300:5	1.25" x 4.88" x 2.19" x 4.68"	PDS-CTSC-031
400:5	1.25" x 4.88" x 2.19" x 4.68"	PDS-CTRC-041
500:5	1.25" x 5.10" x 3.00" x 5.50"	PDS-CTRC-051
600:5	1.25" x 5.10" x 3.00" x 5.50"	PDS-CTRC-061
800:5	1.25" x 5.10" x 3.00" x 5.50"	PDS-CTRC-081
1000:5	1.25" x 5.10" x 3.00" x 5.50"	PDS-CTRC-101
100:5	2.25" x 6.31" x 3.00" x 5.82"	PDS-CTRC-012
200:5	2.25" x 6.31" x 3.00" x 5.82"	PDS-CTRC-022
300:5	2.25" x 6.31" x 3.00" x 5.82"	PDS-CTRC-032
400:5	2.25" x 6.31" x 3.00" x 5.82"	PDS-CTRC-042
800:5	4.00" x 6.44" x 3.25" x 3.25"	PDS-CTRC-084
1000:5	4.00" x 6.44" x 3.25" x 3.25"	PDS-CTRC-104
1200:5	4.00" x 6.44" x 3.25" x 3.25"	PDS-CTRC-124
1600:5	4.00" x 6.44" x 3.25" x 3.25"	PDS-CTRC-164
2000:5	4.00" x 6.44" x 3.25" x 3.25"	PDS-CTRC-204
3200:5	6.50" x 9.88" x 7.00" x 7.00"	PDS-CTRC-326
4000:5	6.50" x 9.88" x 7.00" x 7.00"	PDS-CTRC-426

#### Shorting Block

All low-voltage current transformers should be installed with a shorting block to allow for easy removal of the metering unit and to provide a safe method for disconnecting the CT signal. One shorting block is required per meter. Various size shorting blocks are available; 4, 6, and 8 pole configurations are available with four slotted shorting screws and cover. Wire size is 18-10 AWG.

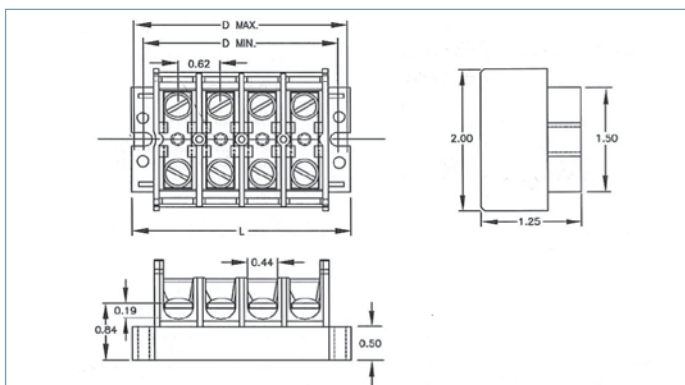

Catalog Number	Ckts.	Mounting		
		L	D min.	D max.
IKU4SC	4	3.25	2.88	3.00
IKU6SC	6	4.50	4.12	4.25
IKU8SC	8	5.75	5.38	5.50
IKU12SC	12	8.25	7.88	8.00

#### Typical electrical meter CT and shorting block installation

This example shows a common three phase, three wire installation where three CT's and one shorting block are used.

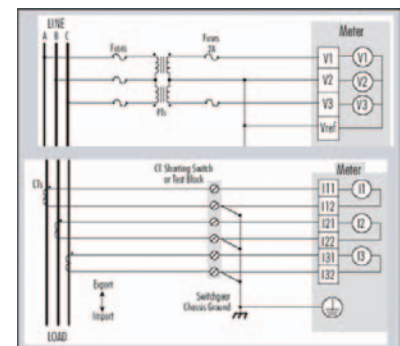

# Power Distribution Solutions

## Powermanager

**A power management system that can be customized to your needs. View and control your facilities' infrastructure condition from anywhere.**

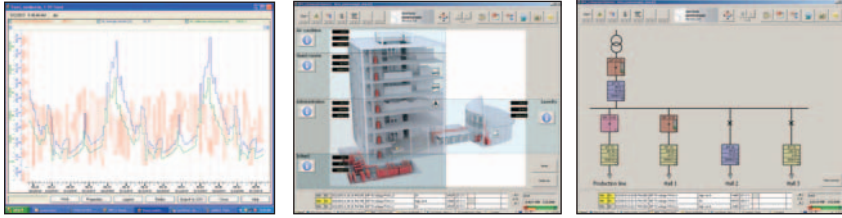

**SENTRON Powermanager** software, combined with Siemens power meters and low-voltage protective devices, provides a complete energy management solution for your business. It allows you to measure, process, analyze, store and share energy usage and status information across your entire enterprise. It offers control capabilities, comprehensive energy usage and reliability, and detailed reporting that will help you reduce energy related costs.

### Cost allocation and Sub-billing Reports

Cost allocation and sub-billing functionality in the Powermanager software allows the user to track energy related costs by building, floor, tenant, feeder or location. Match virtually any fixed rate billing structure and use comprehensive multi-year scheduling and time-of-use features to manage the energy costs.

### Load Studies and Asset Management

Trend power usage data to take full advantage of your electrical distribution system capacity and avoid over-design. Create usage profiles that will allow you to distribute loads and avoid demand peak which helps to identify energy leaks such as equipment running during down time.

### Equipment Monitoring and Control

Powermanager allows you to meter all your utilities including gas, steam, air and water and set up general condition alarming and pre-event alarms for impending or imminent conditions. Interface with other energy management and SCADA systems through multiple communication channels and protocols like OPC.

### Reports

Standard reports provide models of daily electricity usage so you can distribute loads and avoid demand peaks. This enables you to allocate energy consumption and/or costs to individual areas and identify expensive processes that need attention. The historic trending report compiles data from load circuits over a users predefined period. This enables the user to fully utilize the power distribution system and run at near rated tolerances.

### Benefits

- Visibility and control of power flows
- Exact knowledge of the consumption profile
- Increase of energy efficiency
- Optimization of power supply contracts
- Compliance with contractual terms or regulations
- Allocation of costs to individual cost centers
- Optimization of plant maintenance
- Identification of critical systems conditions

### The Powermanager software:

- Is available in a stand-alone or LAN/WAN based configuration that can also exchange information with other supervisory systems like building automation software
- Can utilize any Ethernet or serial based connections
- Is expandable from the basic monitoring application to a fully customized enterprise management system
- Is fully scalable with regard to the connected devices and to the software's function to meet current and future needs
- Ensures the seamless integration of power monitoring devices from the Siemens SENTRON PAC Series Meter, SEM3, and SENTRON WL/WL/3VA circuit breakers as well as other Modbus communicating devices
- Is designed to collect, archive, monitor, display and evaluate any kind of energy related device data
- Provides web based reporting and detailed graphics construction utilities as standard

### Ordering information

Powermanager Software and Device License	Catalog Number
POWERMANAGER BASIC 10 DEVICES	3ZS27110CC300YA0
POWERMANAGER 10 DEVICES with Expert MODE	3ZS27118CC300YA0
POWERMANAGER 20 ADTNL.DEVICES	3ZS27110CC300YD0
POWERMANAGER 50 ADTNL.DEVICES	3ZS27120CC300YD0
POWERMANAGER 100 ADTNL.DEVICES	3ZS27130CC300YD0
POWERMANAGER 200 ADTNL.DEVICES	3ZS27140CC300YD0
POWERMANAGER 500 ADTNL.DEVICES	3ZS27150CC300YD0
POWERMANAGER 1000 ADTNL.DEVICES	3ZS27160CC300YD0
Powermanager Add Ons and Upgrades	Catalog Number
POWERMANAGER OPT PACKAGE EXPERT	3ZS27102CC200YH0
POWERMANAGER OPT PACKAGE CLIENT5	3ZS27103CC000YD0
POWERMANAGER OPT PACKAGE 2 x DISTRIBUTION SYS	3ZS27181CC000YH0
POWERMANAGER OPT PACKAGE 5 x DISTRIBUTION SYS	3ZS27182CC000YH0
POWERMANAGER OPT PACKAGE 10 x DISTRIBUTION SYS	3ZS27183CC000YH0

Contact Siemens for upgrade information



# Power Distribution Solutions

## WinPM.Net Enhanced Web-Enabled Energy Management Software



**WinPM.Net** is a complete energy information management solution for your business allowing you to process, analyze, store and share energy usage and power quality data across your entire enterprise. It offers control capabilities, comprehensive power quality and reliability analysis and can help you reduce energy-related costs. WinPM.net allows you to manage intelligent metering and protective devices, analyze data, and decide on new courses of action to help you save money and keep your business up and running.

Its cutting-edge flexibility and compatibility means you can add one piece at a time, at your own pace, while still maintaining your original investments. Interface to your existing systems through industry-standard protocols and choose newer components as they become available.

### The WinPM.Net software:

- Provides detailed analysis of the power quality and overlays waveforms to correlate phase-to-phase relationships between voltages and currents and cascading failures
- Pinpoints the sources of transients, harmonics, or sags, whether external or internal to your facility, allowing you to decide on the right corrective actions. By monitoring circuits 24 hours a day, you can develop strategies to avoid interruptions
- Provides a comprehensive graphics utility as standard to build and edit any graphical screen whether it is a standard screen or a customized one. These custom screens can display real-time and historical data, alarms, status indications, meter, relay and third party equipment information
- Supports Modbus RTU, Modbus TCP, ION, XML, OPC, FTP, and PQDIF compliant systems, so you can unify your diverse operations into one system. Interface to other energy management software, or include transducers, PLCs, and RTUs in a WinPM.net network. OPC can extract values from other software databases then combine these values with up-to-date readings from WinPM.net to perform real time calculations
- Offers easy, cost effective and fast system expansion. The system grows as your needs grow. Add one piece at a time, at your own pace, within your own budget

### Cost allocation and sub-billing

Track energy-related costs by building, feeder, or tool. Match virtually any billing structure and use comprehensive multi-year scheduling and time-of-use activity profiles.

### Load studies and asset management

Trend power usage data to take full advantage of your electrical distribution system capacity and avoid over-design. Create usage profiles so you can distribute loads and avoid demand peak.

### Demand and power factor control

Eliminate penalties through automated power factor correction, load shedding, or peak shaving.

### Equipment monitoring and control

Meter all your utilities including gas, steam, air and water. Set up alarms for pending problems, pre-alarm on impending or imminent conditions. Interface with other energy management and SCADA systems through multiple communication channels and protocols.

### Ordering information

Software	Catalog Number
WinPM.NET V8.0 DVD New (Includes 5 meter device licenses, 1 Eng Client, 2 Web Clients, New! Dashboards & PQDIF)	3ZS67100CC800BA0
WinPM.NET V8.0 DVD Replacement	3ZS67100CC800BC0
<b>Device License</b>	
WinPM.Net V8.0 9xxx Meter Device License Limit 6 to 50	3ZS68120CC800BA2
WinPM.Net V8.0 9xxx Meter Device License Limit 51 to 100	3ZS68130CC800BA2
WinPM.Net V8.0 9xxx Meter Device License Limit 101 to 1000	3ZS68140CC800BA2
WinPM.Net V8.0 3rd Party device/Modbus/SeaBus Dev. Lic. Limit 1 to 50	3ZS68220CC800BA2
WinPM.Net V8.0 3rd Party device/Modbus/SeaBus Dev. Lic. Limit 51 to 100	3ZS68230CC800BA2
WinPM.Net V8.0 3rd Party device/Modbus/SeaBus Dev. Lic. Limit 101 to 1000	3ZS68240CC800BA2
<b>Options</b>	
WinPM.Net V8.0 Engineering Client License Limit 1 to 50	3ZS67220CC800BA2
WinPM.Net V8.0 Engineering Client License Limit 51 to 100	3ZS67230CC800BA2
WinPM.Net V8.0 Web Client License	3ZS67420CC800BA2
WinPM.Net V8.0 OPC Server License	3ZS67520CC800BA2
WinPM.NetSQL Server 2017 – 2 CORE License increment (***) Minimum of 4 cores per server is required (2 x 3ZS67317CC800BA0)	3ZS67317CC800BA0
<b>Software upgrade</b>	
Contact your local SIEMENS DSS Business Developer for ordering information and upgrade. Allows remote configuration of base WinPM.Net software. Excel is required for excel base reports using Reporter. Outlook is required for e-mailing reports.	

# Power Distribution Solutions

Digitalization for Smart Infrastructure

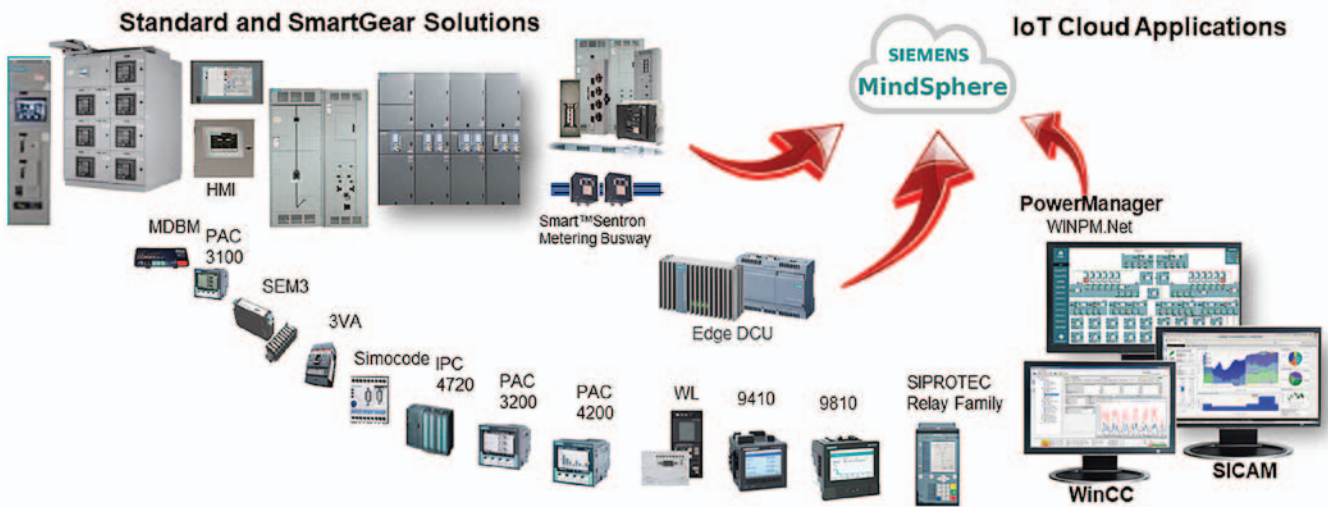

## Cloud & IIoT Solution Offerings

The Siemens Digital Solutions & Services team offers a complete portfolio of digitally enabled products that provide access to data for customers to manage and monitor their assets, as well as analytical insights into their electrical infrastructure.

### Provides:

- Edge Connectivity for Cloud Applications
- Plug & Play for Siemens LP Products
- Simplified Dashboarding of Connected Assets
- Mobile, Tablet, & Desktop Compatible
- Multiple Data Export Options
- MindSphere Enabled

## Edge Data Collection Unit (DCU)

- Collects field-level device data and stores locally at the edge
- Predefined asset model for automatic configuration of MindSphere assets
- Custom Dashboarding of live data
- Dual Ethernet ports for local and external networks
- Easily connect and monitor standard modbus devices
- Standard device drivers for LP equipment::
  - PAC Power Meters
  - ACCESS Power Meters
  - SEM3
  - 3WL, 3VA, 3VL
- Energy usage and cost breakdown for sub-billing
- One-time or scheduled data export via FTP, USB, and Email
- On-board storage options with or without local display



## Cloud Connectivity and Applications

Data aggregated in the Edge DCU can be pushed to an external server or cloud platform for long-term storage. The Edge DCU also offers greater flexibility in configuring and creating a hierarchy of your assets. By doing configuration at the local level and pushing this structure to cloud platforms, such as MindSphere, it removes the need of programming the traditional MindConnect devices in the cloud, transferring the configuration files to USB, before loading directly onto hardware. Cloud connectivity empowers customers to realize value from their data by giving them access to their data outside of their facility. This allows customer to interact with

their data using applications built by Siemens experts, or develop new applications for specific requirements. Using the Siemens cloud applications, users have the ability to choose and change displays to the specific metrics of interest, view and compare time-series data of similar devices, and configure and export reports.

# Power Distribution Solutions

## Services



### Advantages to You...

- Technical experts
- Single source supplier
- Available 24/7, 365 days a year
- Reduced total cost of ownership (TCO)
- Avoid unscheduled downtime with preventive maintenance

## Service Products

Modular service products enable you to customize a technical service agreement to meet your organization's maintenance needs over the entire life cycle of your installation. Including Service products in your TSA will provide the following benefits:

- Substantial savings versus "on demand" purchases
- Optimized scaling of your maintenance organization
- Assurance that your installation is operating at maximum performance and availability

### Telephone and Internet

Priority support

When you need help right now, choose the support coverage that fits your business:

- 24 hours x 7 days a week
- 8 hours x 5 days a week

### Extended support

With extended support, you can request blocks of support hours for specific projects and tasks. We can customize this support service to meet your individual needs.

### Remote service

Remote service provides support and diagnostics via data line to save you time and money. Technical support specialists directly access your system for real-time troubleshooting to provide maximum uptime.

### Technical account liaison

A technical account liaison provides consulting and guidance on all aspects of support through familiarity with the application, your business goals and processes, and your maintenance and engineering staff.

In addition to a site visit to assess your installation and support requirements, the technical account liaison will conduct monthly reviews with your staff to ensure you are receiving maximum payback on your investment.

### Field services

Block of hours

Purchase field service hours in 40 hour increments for preventative, predictive or emergency services.

### Maintenance programs

Packaged maintenance programs available for:

- System performance checks
- Run diagnostics
- Analyze power quality
- Visual inspections of key system components
- Database trim and backup

### Training

Operation and maintenance  
Siemens training offers a broad range of educational services, providing quality and excellence to the automation industry. Targeted product and system training provides the student with practical, hands-on experience.

### Customized on-site training

On-site training is excellent for large groups or when individual, one-on-one instruction is needed. When the trainer visits your facility, product training will be conducted on your specific installation. Classroom lectures, and trouble-shooting techniques specific to your installation are covered in detail during the training session.

### Software update service

The software update service enables you to take advantage of enhancements to the most current software versions. A site evaluation is conducted to determine necessary upgrade requirements prior to the Software Update Service.

# Power Distribution Solutions

Notes

9

POWER  
MONITORING