

# PowerFlex 755TS Products with TotalFORCE Control

Catalog Numbers 20G2, 20GE



Topic	Page
Summary of Changes	2
Introduction	2
Catalog Number Explanation	3
Product Selection—200...240V PowerFlex 755TS Drives	8
Product Selection—480V PowerFlex 755TS Drives	14
Certifications and Specifications	22
Design Considerations	31
Approximate Watts Loss	32
Derating Guidelines	35
Minimum Dynamic Brake Resistance	205
Fuse and Circuit Breaker Ratings	208
Cable Considerations	220
Motor Considerations	221
Dimensions and Weights	221
Enclosure Options	224
Pollution Degree Ratings According to EN 61800-5-1	224
Product Enclosure Ratings	224
Minimum Mounting Clearances	225
PowerFlex 755TS Drives Approximate Dimensions	226
Drive Options	244
Additional Resources	255

## Summary of Changes

This publication contains the following new or updated information. This list includes substantive updates only and is not intended to reflect all changes.

Topic	Page
Added 208V, 240V, 600V, and 690V product ratings.	Throughout
Added Calculate Effective Rating section.	35
Redesigned and expanded the Derating Guidelines section.	35...204

## Introduction

PowerFlex® 755TS products with TotalFORCE® technology offer precise motor control and the ability to adapt to the dynamics experienced in industrial applications. TotalFORCE technology delivers exceptional motor control through precise, adaptive control of position, velocity, and torque for electric motors. It incorporates several patented features that are designed to help optimize your system and maintain productivity.

Maximize your productivity by taking advantage of the following key features that are offered in the PowerFlex 755TS products with TotalFORCE technology:

- **DeviceLogix™** – Embedded control technology that supports the manipulation of discrete outputs and drive control functions, while using discrete inputs and drive status information onboard the drive.
- **Predictive Maintenance** – Helps improve productivity by estimating the remaining life span of drive components so preventive action can be taken before component wear-out causes unplanned downtime.
- **Option Cards** – Each drive has a slot-based architecture. Supported hardware control options are available for both products, to help reduce your inventory and spare parts requirements.
- **I/O** – Option cards are available for additional analog and digital I/O.
- **Patented slot-based hardware structure** – Allows you to select option modules for safety, feedback, communications, and I/O.
- **Safe Torque Off and Safe Speed Monitor** – Provide a choice for safety levels depending on your application requirements.
- **Load Observer** – Maintain productivity with control that adapts to operating conditions.
- **Ride-Through** – Helps keep equipment running through power quality disturbances.
- **TorqProve™** – Patented control coordinates motor torque and brake operation in hoist applications.
- **Communications** – The PowerFlex 755TS products feature built-in Gigabit EtherNet/IP™ ports.
- **Packaging** – Factory and field-installable enclosure options are available to meet most environmental requirements. Options include Open Type and flange mount to support cabinet mount requirements, extra protection wall-mount for harsh environments, and debris hoods and conduit plate kits.



# Catalog Number Explanation

Catalog number positions 1..7 identify the product type and voltage rating.

1..3	4	5	6	7	8..10	11	12	13	14	15	16	17	18
20G	2	A	N	D	248	J	N	O	N	N	N	N	N
	A	B	C	D	E								

## A

Drive		
Code	Type	Frames
20G	PowerFlex 755TS Drives	1..7

## B

Corrosive Gas Protection and Cooling Type		
Code	Description	Frames
2	Standard Protection, Forced Air	1..7
E	Corrosive Gas Protection (XT), Forced Air	1..7

## C

Input Type		
Code	Description	Frames
1	AC Input with Precharge, includes DC terminals	1..5
4	DC Input with Precharge	5..7
A	AC Input with Precharge, no DC terminals	6 and 7 <sup>(1)</sup>

(1) The DC Bus Bar kit (20-750-DCBB3-Fn) is available for Frames 6 and 7 AC input drives that require DC bus terminals.

## D

Enclosure		
Code	Description	Frames
R	IP20, NEMA/UL Open Type, Frame 1	1
F <sup>(1)</sup>	Flange, NEMA/UL Type 4X/12 back	2..5
G	IP54, NEMA/UL Type 12	2..7
N <sup>(2)</sup>	IP20/IP00, NEMA/UL Open Type	2..7

(1) For Frames 6..7, a user installed flange kit (20-750-FLNG4-Fn) is available to convert a Code N drive that provides a NEMA/UL Type 4X/12 back.

(2) Frames 2..5 are IP20, Frames 6..7 are IP00.

## E

Voltage Rating	
Code	Voltage
B	240V AC (208V AC) <sup>(1)(2)</sup>
C	400V AC/540V DC
D	480V AC/650V DC
E	600V AC/810V DC
F	690V AC/932V DC (not UL Listed)

(1) Drive must be programmed to obtain low (208V AC) voltage rating.

(2) 240V AC (208V AC) Code B drives do not support Code 4 input type (DC Input with Precharge).

Catalog number positions 8...10 identify the product normal duty rating.

1...3 4 5 6 7 8...10 11 12 13 14 15 16 17 18  
 20G 2 A N D 248 J N O N N N N N

F1...F6

**F1**

PowerFlex 755TS ND Drive Ratings						
208V, 60 Hz Input						
Code	Amps	kW	Frame			
			Enclosure Code			
			F	G	N	R
2P2	2.5	0.37				
4P2	4.8	0.75				
6P8	7.8	1.5	-	-	-	1
9P6	11	2.2				
015	15.3	4				
2P2	2.5	0.37				
4P2	4.8	0.75				
6P8	7.8	1.5	2	2	2	
9P6	11	2.2				
015	17.5	4				
022	22	5.5				
028	32.2	7.5	3	3	3	
042	43	11				
054	60	15	4	4	4	
055	61	15	-	-	3	
070	78.2	18.2	5	5	5	-
071	79	18.2	4	-	4	
080	92	22	5		5	
104	120	30				
130	150	37		6		
154	177	45	6 <sup>(1)</sup>		6	
192	221	55				
260	260	66				
312	359	90		7		
360	414	110	7 <sup>(1)</sup>		7	
477	477	132		-		

**F2**

PowerFlex 755TS ND Drive Ratings						
240V, 60 Hz Input						
Code	Amps	Hp	Frame			
			Enclosure Code			
			F	G	N	R
2P2	2.2	0.5				
4P2	4.2	1				
6P8	6.8	2	-	-	-	1
9P6	9.6	3				
015	15.3	5				
2P2	2.2	0.5				
4P2	4.2	1				
6P8	6.8	2	2	2	2	
9P6	9.6	3				
015	15.3	5				
022	22	7.5				
028	28	10	3	3	3	
042	42	15				
054	54	20	4	4	4	
055	55	20	-	-	3	
070	70	25	5	5	5	-
071	71	25	4	-	4	
080	80	30	5		5	
104	104	40				
130	130	50		6		
154	154	60	6 <sup>(1)</sup>		6	
192	192	75				
260	260	100				
312	312	125		7		
360	360	150	7 <sup>(1)</sup>		7	
477	477	200		-		

(1) For Frames 6 and 7, a field-installed flange kit (20-750-TFLNG1-Fn) is available to convert a Code N drive to provide a NEMA/UL Type 4X/12 back.

**F3**

PowerFlex 755TS ND Drive Ratings						
400V, 50 Hz Input						
Code	Amps	kW	Frame			
			Enclosure Code			
			F	G	N	R
2P1	2.1	0.75	2	2	2	1
3P5	3.5	1.5				
5P0	5.0	2.2				
8P7	8.7	4				
011	11.5	5.5				
015	15.4	7.5				
022	22	11				
030	30	15				
037	37	18.5	3	3	3	
043	43	22				
060	60	30				
061	61	30	—	—	3	
072	72	37	4	5	4	
073	73	37	—	4	—	
085	85	45	5	5	5	
086	86	45	4	—	4	—
104	104	55	5	6 <sup>(1)</sup>	6	
140	140	75				
170	170	90				
205	205	110				
260	260	132				
302	302	160	7 <sup>(1)</sup>	7	7	
367	367	200				
456	456	250				
477	477	270				

**F4**

PowerFlex 755TS ND Drive Ratings						
480V, 60 Hz Input						
Code	Amps	Hp	Frame			
			Enclosure Code			
			F	G	N	R
2P1	2.1	1	2	2	2	1
3P4	3.4	2				
5P0	5.0	3				
8P0	8.0	5				
011	11	7.5				
014	14	10				
022	22	15				
027	27	20				
034	34	25	3	3	3	
040	40	30				
052	52	40				
053	53	40	—	—	3	
065	65	50	4	5	4	
066	66	50	—	4	—	
077	77	60	5	5	5	
078	78	60	4	—	4	—
096	96	75	5	6 <sup>(1)</sup>	6	
125	125	100				
156	156	125				
186	186	150				
248	248	200				
302	302	250	7 <sup>(1)</sup>	7	7	
361	361	300				
415	415	350				
477	477	400				

(1) For Frames 6 and 7, a field-installed flange kit (20-750-TFLNG1-Fn) is available to convert a Code N drive to provide a NEMA/UL Type 4X/12 back.

**F5**

PowerFlex 755TS ND Drive Ratings						
600V, 60 Hz Input						
Code	Amps	Hp	Frame			
			Enclosure Code			
			F	G	N	R
1P7	1.7	1				
2P7	2.7	2				
3P9	3.9	3				
6P1	6.1	5				
9P0	9	7.5				
011	11	10				
012	12	10	—	6	6	
017	17	15	3	3	3	
018	18	15	—	6	6	
022	22	20	3	3	3	
023	23	20				
024	24	20	—	6	6	
027	27	25	4	4	4	
028	28	25	—	6	6	
032	32	30	4	4	4	—
033	33	30	—	6	6	
041	41	40	5	5	5	
042	42	40	—	6	6	
052	52	50	5	—	5	
053	53	50				
063	63	60				
077	77	75				
099	99	100	6 <sup>(1)</sup>	6	6	
125	125	125				
144	144	150				
192	192	200				
242	242	250	7 <sup>(1)</sup>	7	7	
289	289	300				

**F6**

PowerFlex 755TS ND Drive Ratings						
690V, 50 Hz Input						
Code	Amps	kW	Frame			
			Enclosure Code			
			F	G	N	R
012	12	7.5				
015	15	11				
020	20	15				
023	23	18.5				
030	30	22				
034	34	30				
046	46	37	6 <sup>(1)</sup>	6	6	
050	50	45				
061	61	55				—
082	82	75				
098	98	90				
119	119	110				
142	142	132				
171	171	160				
212	212	200	7 <sup>(1)</sup>	7	7	
263	263	250				

(1) For Frames 6 and 7, a field-installed flange kit (20-750-TFLNG1-Fn) is available to convert a Code N drive to provide a NEMA/UL Type 4X/12 back.

Catalog number positions 11...13 identify additional product configuration.

1...3 4 5 6 7 8...10 11 12 13 14 15 16 17 18  
 20G 2 A N D 248 J N O N N N N N N  
 G H I

**G**

**Filtering and CM Cap Configuration**

Code	Filtering	Default CM Cap Connection	Frames
J	Yes	Jumper Installed	1...7

**H**

**Dynamic Braking**

Code	Internal Resistor <sup>(1)</sup>	Internal Transistor <sup>(2)</sup>	Frames
A	No	Yes	1...7
N	No	No	6 and 7

(1) Frames 1...2 only. Internal Resistor kits (20-750-DB1-Dn) sold separately.

(2) Standard on Frames 1...5, optional on 6 and 7.

**I**

**Human Interface Module (HIM) <sup>(1)</sup>**

Code	Operator Interface	Frames
O	No HIM	1...7

(1) Order a HIM option (20-HIM-A6 handheld/local or 20-HIM-C6S IP66, NEMA Type 4X/12) separately for PowerFlex 755TS products.

Catalog number positions 14...18 are not used.

1...3 4 5 6 7 8...10 11 12 13 14 15 16 17 18  
 20G 2 A N D 248 J N O N N N N N N

# Product Selection—200...240V PowerFlex 755TS Drives

## 200...240V AC, Three-phase Drives—IP00/IP20, NEMA/UL Type Open <sup>(1)</sup>

Normal Duty				Heavy Duty				Cat. No. <sup>(3) (4) (5)</sup>	Frame Size
Output Amps: 240V (208V) <sup>(2)</sup>			Hp (kW)	Output Amps: 240V (208V) <sup>(2)</sup>			Hp (kW)		
Cont.	1 min	3 s		Cont.	1 min	3 s			
2.2 (2.5)	2.4 (2.8)	3.3 (3.8)	0.5 (0.37)	2.2 (2.5)	4.6 (2.8)	6.3 (3.8)	0.5 (0.37)	20G21RB2P2JA0NNNNN	1
4.2 (4.8)	4.6 (5.3)	6.3 (7.2)	1 (0.75)	2.2 (2.5)	7.5 (5.3)	10.2 (7.2)	0.5 (0.37)	20G21RB4P2JA0NNNNN	
6.8 (7.8)	7.5 (8.6)	10.2 (11.7)	2 (1.5)	4.2 (4.8)	10.6 (8.6)	14.4 (11.7)	1 (0.75)	20G21RB6P8JA0NNNNN	
9.6 (11)	10.6 (12.1)	14.4 (16.5)	3 (2.2)	6.8 (7.8)	16.8 (12.1)	23 (16.5)	2 (1.5)	20G21RB9P6JA0NNNNN	
15.3 (15.3)	16.8 (16.9)	23 (23)	5 (4)	9.6 (11)	16.9 (16.9)	23 (23)	3 (2.2)	20G21RB015JA0NNNNN	
2.2 (2.5)	3.3 (3.8)	4 (4.5)	0.5 (0.37)	2.2 (2.5)	3.3 (3.8)	4 (4.5)	0.5 (0.37)	20G21NB2P2JA0NNNNN	2
4.2 (4.8)	6.3 (7.2)	7.6 (8.6)	1 (0.75)	4.2 (4.8)	6.3 (7.2)	7.6 (8.6)	1 (0.75)	20G21NB4P2JA0NNNNN	
6.8 (7.8)	10.2 (11.7)	12.2 (14)	2 (1.5)	6.8 (7.8)	10.2 (11.7)	12.2 (14)	2 (1.5)	20G21NB6P8JA0NNNNN	
9.6 (11)	14.4 (16.5)	17.3 (19.8)	3 (2.2)	9.6 (11)	14.4 (16.5)	17.3 (19.8)	3 (2.2)	20G21NB9P6JA0NNNNN	
15.3 (17.5)	16.8 (19.3)	23 (26.3)	5 (4)	9.6 (17.5)	16.8 (16.9)	23 (23)	3 (2.2)	20G21NB015JA0NNNNN	
22 (22)	24.2 (24.2)	33 (33)	7.5 (5.5)	15 (15.3)	24.2 (24.2)	33 (33)	5 (4)	20G21NB022JA0NNNNN	3
28 (32.2)	30.8 (35.4)	42 (48.3)	10 (7.5)	22 (32.2)	33 (35.4)	42 (48.3)	7.5 (5.5)	20G21NB028JA0NNNNN	
42 (43)	46.2 (47.3)	63 (64.5)	15 (11)	28 (43)	46.2 (48.3)	63 (64.5)	10 (7.5)	20G21NB042JA0NNNNN	
55 (61)	60.5 (67.1)	82.5 (91.5)	20 (15)	42 (61)	63 (64.5)	81 (90)	15 (11)	20G21NB055JA0NNNNN	4
54 (60)	59.4 (66)	81 (90)	20 (15)	42 (60)	63 (64.5)	81 (90)	15 (11)	20G21NB054JA0NNNNN	
71 (79)	78.1 (86.9)	106.5 (117.3)	25 (18.5)	54 (79)	81 (90)	105 (117.3)	20 (15)	20G21NB071JA0NNNNN	5
70 (78.2)	77 (86)	105 (117.3)	25 (18.5)	54 (78.2)	81 (90)	105 (117.3)	20 (15)	20G21NB070JA0NNNNN	
80 (92)	88 (101.2)	120 (138)	30 (22)	70 (92)	105 (117.3)	126 (140.8)	25 (18.5)	20G21NB080JA0NNNNN	6
104 (120)	114.4 (132)	156 (180)	40 (30)	80 (120)	120 (138)	156 (180)	30 (22)	20G2ANB104JA0NNNNN <sup>(6)</sup>	
130 (150)	143 (165)	195 (225)	50 (37)	104 (150)	156 (180)	195 (225)	40 (30)	20G2ANB130JA0NNNNN <sup>(6)</sup>	
154 (177)	169.4 (194.7)	231 (265.5)	60 (45)	130 (177)	195 (225)	234 (270)	50 (37)	20G2ANB154JA0NNNNN <sup>(6)</sup>	
192 (221)	211.2 (243.1)	288 (331.5)	75 (55)	154 (221)	231 (265.5)	288 (331.5)	60 (45)	20G2ANB192JA0NNNNN <sup>(6)</sup>	
260 (260)	286 (286)	390 (390)	100 (66)	192 (260)	288 (331.5)	390 (390)	75 (55)	20G2ANB260JA0NNNNN <sup>(6)</sup>	7
312 (359)	343.2 (394.9)	468 (538.5)	125 (90)	260 (359)	390 (394.9)	468 (646.2)	100 (66)	20G2ANB312JA0NNNNN <sup>(6)</sup>	
360 (414)	396 (455.4)	540 (621)	150 (110)	312 (414)	468 (538.5)	561.6 (646.2)	125 (90)	20G2ANB360JA0NNNNN <sup>(6)</sup>	
477 (477)	524.7 (524.7)	715.5 (715.5)	200 (132)	312 (414)	468 (538.5)	561.6 (646.2)	125 (90)	20G2ANB477JA0NNNNN <sup>(6)</sup>	

(1) Frames 1...5 are IP20, NEMA/UL Type Open. Frames 6...7 are IP00, NEMA/UL Type Open. Frames 1...7 can be converted to IP20, NEMA/UL Type 1 with optional kit (20-750-NEMA1-Fn), where n is the frame size.

(2) Drive must be programmed to lower voltage to obtain the currents shown in parentheses.

(3) The 4th character determines corrosive gas protection; "2" = standard protection, and "E" = corrosive gas protection (XT).

(4) The 5th character determines Input Type; "1" = AC input with precharge and DC terminals for frames 1...5, "4" = DC input with precharge for frames 5...7, and "A" = AC input with precharge and no DC terminals for frames 6 and 7. For DC input drives, see [PFLX-SG002](#), the PowerFlex Low Voltage Drives Selection Guide.

(5) The 11th character indicates the default Filtering and Common Mode Cap jumper configuration. All products ship with jumpers installed, code "J".

(6) The 12th character determines whether an internal dynamic braking IGBT is included; "A" = Internal dynamic braking transistor installed, and "N" = No internal dynamic braking transistor.

## 200...240V AC, Three-phase Drives—IP54, NEMA/UL Type 12

Normal Duty				Heavy Duty				Cat. No. <sup>(2) (3) (4)</sup>	Frame Size
Output Amps: 240V (208V) <sup>(1)</sup>			Hp (kW)	Output Amps: 240V (208V) <sup>(1)</sup>			Hp (kW)		
Cont.	1 min	3 s		Cont.	1 min	3 s			
2.2 (2.5)	3.3 (3.8)	4 (4.5)	0.5 (0.37)	2.2 (2.5)	3.3 (3.7)	3.9 (4.5)	0.5 (0.37)	20G21GB2P2JAONNNNN	2
4.2 (4.8)	6.3 (7.2)	7.6 (8.6)	1 (0.75)	4.2 (4.8)	6.3 (7.2)	7.5 (8.6)	1 (0.75)	20G21GB4P2JAONNNNN	
6.8 (7.8)	10.2 (11.7)	12.2 (14)	2 (1.5)	6.8 (7.8)	10.2 (11.7)	12.2 (14)	2 (1.5)	20G21GB6P8JAONNNNN	
9.6 (11)	14.4 (16.5)	17.2 (19.8)	3 (2.2)	9.6 (11)	14.4 (16.5)	17.3 (19.8)	3 (2.2)	20G21GB9P6JAONNNNN	
15.3 (17.5)	16.8 (19.2)	22.9 (26.2)	5 (4)	9.6 (11)	16.8 (19.2)	22.9 (26.2)	3 (2.2)	20G21GB015JAONNNNN	
22 (22)	24.2 (24.2)	33 (33)	7.5 (5.5)	15.3 (17.5)	24.2 (24.2)	33 (33)	5 (4)	20G21GB022JAONNNNN	
28 (32.2)	30.8 (35.4)	42 (48.3)	10 (7.5)	22 (22)	33 (35.4)	42 (48.3)	7.5 (5.5)	20G21GB028JAONNNNN	3
42 (43)	46.2 (47.3)	63 (64.5)	15 (11)	28 (32.2)	46.2 (48.3)	63 (64.5)	10 (7.5)	20G21GB042JAONNNNN	
55 (61)	60.5 (67.1)	82.5 (91.5)	20 (15)	42 (61)	63 (64.5)	81 (90)	15 (11)	20G21GB055JAONNNNN	
54 (60)	59.4 (66)	81 (90)	20 (15)	42 (43)	63 (64.5)	81 (90)	15 (11)	20G21GB054JAONNNNN	4
71 (79)	78.1 (86.9)	106.5 (117.3)	25 (18.5)	54 (79)	81 (90)	105 (117.3)	20 (15)	20G21GB071JAONNNNN	
70 (78.2)	77 (86)	105 (117)	25 (18.5)	54 (60)	81 (90)	105 (117)	20 (15)	20G21GB070JAONNNNN	5
80 (92)	88 (101)	120 (138)	30 (22)	70 (78.2)	105 (117)	126 (140)	25 (18.5)	20G21GB080JAONNNNN	
104 (120)	114 (132)	156 (180)	40 (30)	80 (92)	120 (138)	156 (180)	30 (22)	20G2AGB104JAONNNNN	6
130 (150)	143 (165)	195 (225)	50 (37)	104 (120)	156 (180)	195 (225)	40 (30)	20G2AGB130JAONNNNN <sup>(5)</sup>	
154 (177)	169 (194)	231 (265)	60 (45)	130 (150)	195 (225)	234 (270)	50 (37)	20G2AGB154JAONNNNN <sup>(5)</sup>	
192 (221)	211.2 (243.1)	288 (331)	75 (55)	154 (177)	231 (265)	288 (331)	60 (45)	20G2AGB192JAONNNNN <sup>(5)</sup>	
260 (260)	286 (286)	390 (390)	100 (66)	192 (221)	288 (331)	390 (390)	75 (55)	20G2AGB260JAONNNNN <sup>(5)</sup>	
312 (359)	343. (394)	468 (538)	125 (90)	260 (260)	390 (394)	468 (538)	100 (66)	20G2AGB312JAONNNNN <sup>(5)</sup>	
360 (414)	396 (455)	540 (621)	150 (110)	312 (359)	468 (538)	561 (646)	125 (90)	20G2AGB360JAONNNNN <sup>(5)</sup>	7
477 (477)	524.7 (524.7)	715.5 (715.5)	200 (132)	312 (414)	468 (538.5)	561.6 (646.2)	125 (90)	20G2AGB477JAONNNNN <sup>(5)</sup>	

(1) Drive must be programmed to lower voltage to obtain the currents shown in parentheses.

(2) The 4th character determines corrosive gas protection; "2" = standard protection, and "E" = corrosive gas protection (XT).

(3) The 5th character determines Input Type; "1" = AC input with precharge and DC terminals for frames 1...5, "4" = DC input with precharge for frames 5...7, and "A" = AC input with precharge and no DC terminals for frames 6 and 7. For DC input drives, see [PFLX-SG002](#), the PowerFlex Low Voltage Drives Selection Guide.

(4) The 11th character indicates the default Filtering and Common Mode Cap jumper configuration. All products ship with jumpers installed, code "J".

(5) The 12th character determines whether an internal dynamic braking IGBT is included; "A" = Internal dynamic braking transistor installed, and "N" = No internal dynamic braking transistor.

**200...240V AC, Three-phase Drives—Flange Mount (Front: IP20, NEMA/UL Type Open; Back/Heatsink: IP66, NEMA/UL Type 4X/12)**

Normal Duty				Heavy Duty				Cat. No. <sup>(2) (3) (4)</sup>	Frame Size
Output Amps: 240V (208V) <sup>(1)</sup>			Hp (kW)	Output Amps: 240V (208V) <sup>(1)</sup>			Hp (kW)		
Cont.	1 min	3 s		Cont.	1 min	3 s			
2.2 (2.5)	3.3 (3.7)	3.9 (4.5)	0.5 (0.37)	2.2 (2.5)	3.3 (3.7)	3.9 (4.5)	0.5 (0.37)	20G21FB2P2JA0NNNNN	2
4.2 (4.8)	6.3 (7.2)	7.5 (8.6)	1 (0.75)	4.2 (4.8)	6.3 (7.2)	7.5 (8.6)	1 (0.75)	20G21FB4P2JA0NNNNN	
6.8 (7.8)	10.2 (11.7)	12.2 (14)	2 (1.5)	6.8 (7.8)	10.2 (11.7)	12.2 (14)	2 (1.5)	20G21FB6P8JA0NNNNN	
9.6 (11)	14.4 (16.5)	17.2 (19.8)	3 (2.2)	9.6 (11)	14.4 (16.5)	17.3 (19.8)	3 (2.2)	20G21FB9P6JA0NNNNN	
15.3 (17.5)	16.8 (19.2)	22.9 (26.2)	5 (4)	9.6 (11)	16.8 (19.2)	22.9 (26.2)	3 (2.2)	20G21FB015JA0NNNNN	
22 (22)	24.2 (24.2)	33 (33)	7.5 (5.5)	15.3 (17.5)	24.2 (24.2)	33 (33)	5 (4)	20G21FB022JA0NNNNN	
28 (32.2)	30.8 (35.4)	42 (48.3)	10 (7.5)	22 (22)	33 (35.4)	42 (48.3)	7.5 (5.5)	20G21FB028JA0NNNNN	3
42 (43)	46.2 (47.3)	63 (64.5)	15 (11)	28 (32.2)	46.2 (48.3)	63 (64.5)	10 (7.5)	20G21FB042JA0NNNNN	
55 (61)	60.5 (67.1)	82.5 (91.5)	20 (15)	42 (61)	63 (64.5)	81 (90)	15 (11)	20G21FB055JA0NNNNN	
54 (60)	59.4 (66)	81 (90)	20 (15)	42 (43)	63 (64.5)	81 (90)	15 (11)	20G21FB054JA0NNNNN	4
71 (79)	78.1 (86.9)	106.5 (117.3)	25 (18.5)	54 (79)	81 (90)	105 (117.3)	20 (15)	20G21FB071JA0NNNNN	
70 (78.2)	77 (86)	105 (117)	25 (18.5)	54 (60)	81 (90)	105 (117)	20 (15)	20G21FB070JA0NNNNN	5
80 (92)	88 (101)	120 (138)	30 (22)	70 (78.2)	105 (117)	126 (140)	25 (18.5)	20G21FB080JA0NNNNN	

- (1) Drive must be programmed to lower voltage to obtain the currents shown in parentheses.
- (2) The 4th character determines corrosive gas protection; "2" = standard protection, and "E" = corrosive gas protection (XT).
- (3) The 5th character determines Input Type; "1" = AC input with precharge and DC terminals for frames 1...5, "4" = DC input with precharge for frames 5...7, and "A" = AC input with precharge and no DC terminals for frames 6 and 7. For DC input drives, see [PFLX-SG002](#), the PowerFlex Low Voltage Drives Selection Guide.
- (4) The 11th character indicates the default Filtering and Common Mode Cap jumper configuration. All products ship with jumpers installed, code "J".

# Product Selection—380...400V PowerFlex 755TS Drives

380...400V AC, Three-phase Drives—IP00/IP20, NEMA/UL Type Open <sup>(1) (2)</sup>

Normal Duty				Heavy Duty				Cat. No. <sup>(3) (4) (5)</sup>	Frame Size
Output Amps			kW	Output Amps			kW		
Cont.	1 min	3 s		Cont.	1 min	3 s			
2.1	2.3	3.2	0.75	1.3	2.3	3.2	0.37	20G21RC2P1JAONNNNN	1
3.5	3.9	5.3	1.5	2.1	3.9	5.3	0.75	20G21RC3P5JAONNNNN	
5	5.5	7.5	2.2	3.5	5.5	7.5	1.5	20G21RC5P0JAONNNNN	
8.7	9.6	13.1	4	5	9.6	13.1	2.2	20G21RC8P7JAONNNNN	
11.5	12.7	17.3	5.5	8.7	13.1	17.3	4	20G21RC011JAONNNNN	
15.4	16.9	23.1	7.5	11.5	17.3	23.1	5.5	20G21RC015JAONNNNN	
2.1	3.1	3.7	0.75	2.1	3.1	3.7	0.75	20G21NC2P1JAONNNNN	2
3.5	5.2	6.3	1.5	3.5	5.2	6.3	1.5	20G21NC3P5JAONNNNN	
5	7.5	9	2.2	5	7.5	9	2.2	20G21NC5P0JAONNNNN	
8.7	13	15.6	4	8.7	13	15.6	4	20G21NC8P7JAONNNNN	
11.5	17.2	20.7	5.5	11.5	17.2	20.7	5.5	20G21NC011JAONNNNN	
15.4	16.9	23.1	7.5	11.5	17.3	23.1	5.5	20G21NC015JAONNNNN	
22	24.2	33	11	15.4	24.3	33	7.5	20G21NC022JAONNNNN	3
30	33	45	15	22	33	45	11	20G21NC030JAONNNNN	
37	40.7	55.5	18.5	30	45	55.5	15	20G21NC037JAONNNNN	
43	47.3	64.5	22	37	55.5	66.6	18.5	20G21NC043JAONNNNN	4
61	67.1	91.5	30	43	66	90	22	20G21NC061JAONNNNN	
60	66	90	30	43	66	90	22	20G21NC060JAONNNNN	5
72	79.2	108	37	60	90	108	30	20G21NC072JAONNNNN	
86	94.6	129	45	72	108	129.6	37	20G21NC086JAONNNNN	6
85	93.5	127.5	45	72	108	129.6	37	20G21NC085JAONNNNN	
104	114.4	156	55	85	127.5	156	45	20G21NC104JAONNNNN	7
140	154	210	75	104	156	210	55	20G2ANC140JAONNNNN <sup>(6)</sup>	
170	187	255	90	140	210	255	75	20G2ANC170JAONNNNN <sup>(6)</sup>	
205	225	307.5	110	170	255	307.5	90	20G2ANC205JAONNNNN <sup>(6)</sup>	
260	286	390	132	205	307.5	390	110	20G2ANC260JAONNNNN <sup>(6)</sup>	
302	332.2	453	160	260	390	468	132	20G2ANC302JAONNNNN <sup>(6)</sup>	
367	403.5	550.5	200	302	453	550.5	160	20G2ANC367JAONNNNN <sup>(6)</sup>	
456	501.6	684	250	367	550.5	684	200	20G2ANC456JAONNNNN <sup>(6)</sup>	
477	524.7	715.5	270	367	550.5	684	200	20G2ANC477JAONNNNN <sup>(6)</sup>	

(1) Frames 1...7 can be converted to IP20, NEMA/UL Type 1 with an optional conversion kit (20-750-TNEMA1-Fn), where n is the frame size of the drive.  
(2) Frames 2...7 IP20/IP00, NEMA/UL Type Open drives can be converted to a flange mount drive (back/heatsink: IP66, NEMA/UL Type 4X) with an optional user-installed flange-mount adapter kit (20-750-TFLNG1-Fn), where n is the frame size of the drive.  
(3) The 4th character determines corrosive gas protection; "2" = standard protection, and "E" = corrosive gas protection (XT).  
(4) The 5th character determines Input Type; "1" = AC input with precharge and DC terminals for frames 1...5, "4" = DC input with precharge for frames 5...7, and "A" = AC input with precharge and no DC terminals for frames 6 and 7. For DC input drives, see [PFLX-S6002](#), the PowerFlex Low Voltage Drives Selection Guide.  
(5) The 11th character indicates the default Filtering and Common Mode Cap jumper configuration. All products ship with jumpers installed, code "J".  
(6) The 12th character determines whether an internal dynamic braking IGBT is included; "A" = internal dynamic braking transistor installed, and "N" = No internal dynamic braking transistor.

### 380...400V AC, Three-phase Drives—IP54, NEMA/UL Type 12

Normal Duty				Heavy Duty				Cat. No. (1) (2) (3)	Frame Size
Output Amps			kW	Output Amps			kW		
Cont.	1 min	3 s		Cont.	1 min	3 s			
2.1	3.1	3.7	0.75	2.1	3.1	3.7	0.75	20G21GC2P1JA0NNNNN	2
3.5	5.2	6.3	1.5	3.5	5.2	6.3	1.5	20G21GC3P5JA0NNNNN	
5	7.5	9	2.2	5	7.5	9	2.2	20G21GC5P0JA0NNNNN	
8.7	13	15.6	4	8.7	13	15.6	4	20G21GC8P7JA0NNNNN	
11.5	17.2	20.7	5.5	11.5	17.2	20.7	5.5	20G21GC011JA0NNNNN	
15.4	16.9	23.1	7.5	11.5	17.3	23.1	5.5	20G21GC015JA0NNNNN	
22	24.2	33	11	15.4	24.3	33	7.5	20G21GC022JA0NNNNN	
30	33	45	15	22	33	45	11	20G21GC030JA0NNNNN	3
37	40.7	55.5	18.5	30	45	55.5	15	20G21GC037JA0NNNNN	
43	47.3	64.5	22	37	55.5	66.6	18.5	20G21GC043JA0NNNNN	
60	66	90	30	43	66	90	22	20G21GC060JA0NNNNN	4
73	80.3	109.5	37	60	90	108	30	20G21GC073JA0NNNNN	
72	79.2	108	37	60	90	108	30	20G21GC072JA0NNNNN	5
85	93.5	127.5	45	72	108	129.6	37	20G21GC085JA0NNNNN	
104	114.4	156	55	85	127.5	156	45	20G2AGC104JA0NNNNN <sup>(4)</sup>	6
140	154	210	75	104	156	210	55	20G2AGC140JA0NNNNN <sup>(4)</sup>	
170	187	255	90	140	210	255	75	20G2AGC170JA0NNNNN <sup>(4)</sup>	
205	225	307.5	110	170	255	307.5	90	20G2AGC205JA0NNNNN <sup>(4)</sup>	
260	286	390	132	205	307.5	390	110	20G2AGC260JA0NNNNN <sup>(4)</sup>	7
302	332.2	453	160	260	390	468	132	20G2AGC302JA0NNNNN <sup>(4)</sup>	
367	403.5	550.5	200	302	453	550.5	160	20G2AGC367JA0NNNNN <sup>(4)</sup>	
456	501.6	684	250	367	550.5	684	200	20G2AGC456JA0NNNNN <sup>(4)</sup>	

(1) The 4th character determines corrosive gas protection; "Z" = standard protection, and "E" = corrosive gas protection (XT).

(2) The 5th character determines Input Type; "I" = AC input with precharge and DC terminals for frames 1...5, "4" = DC input with precharge for frames 5...7, and "A" = AC input with precharge and no DC terminals for frames 6 and 7. For DC input drives, see [PFLX-SG002](#), the PowerFlex Low Voltage Drives Selection Guide.

(3) The 11th character indicates the default Filtering and Common Mode Cap jumper configuration. All products ship with jumpers installed, code "J".

(4) The 12th character determines whether an internal dynamic braking IGBT is included; "A" = Internal dynamic braking transistor installed, and "N" = No internal dynamic braking transistor.

**380...400V AC, Three-phase Drives—Flange Mount (Front: IP20, NEMA/UL Type Open; Back/Heatsink: IP66, NEMA/UL Type 4X)**

Normal Duty				Heavy Duty				Cat. No. (1) (2) (3)	Frame Size
Output Amps			kW	Output Amps			kW		
Cont.	1 min	3 s		Cont.	1 min	3 s			
2.1	3.1	3.7	0.75	2.1	3.1	3.7	0.75	20G21FC2P1JA0NNNNN	2
3.5	5.2	6.3	1.5	3.5	5.2	6.3	1.5	20G21FC3P5JA0NNNNN	
5	7.5	9	2.2	5	7.5	9	2.2	20G21FC5P0JA0NNNNN	
8.7	13	15.6	4	8.7	13	15.6	4	20G21FC8P7JA0NNNNN	
11.5	17.2	20.7	5.5	11.5	17.2	20.7	5.5	20G21FC011JA0NNNNN	
15.4	16.9	23.1	7.5	11.5	17.3	23.1	5.5	20G21FC015JA0NNNNN	
22	24.2	33	11	15.4	24.3	33	7.5	20G21FC022JA0NNNNN	
30	33	45	15	22	33	45	11	20G21FC030JA0NNNNN	3
37	40.7	55.5	18.5	30	45	55.5	15	20G21FC037JA0NNNNN	
43	47.3	64.5	22	37	55.5	66.6	18.5	20G21FC043JA0NNNNN	
60	66	90	30	43	66	90	22	20G21FC060JA0NNNNN	4
72	79.2	108	37	60	90	108	30	20G21FC072JA0NNNNN	
86	94.6	129	45	72	108	129.6	37	20G21FC086JA0NNNNN	
85	93.5	127.5	45	72	108	129.6	37	20G21FC085JA0NNNNN	5
104	114.4	156	55	85	127.5	156	45	20G21FC104JA0NNNNN	

- (1) The 4th character determines corrosive gas protection; "2" = standard protection, and "E" = corrosive gas protection (XT).
- (2) The 5th character determines Input Type; "1" = AC input with precharge and DC terminals for frames 1...5, "4" = DC input with precharge for frames 5...7, and "A" = AC input with precharge and no DC terminals for frames 6 and 7. For DC input drives, see [PFLEX-S6002](#), the PowerFlex Low Voltage Drives Selection Guide.
- (3) The 11th character indicates the default Filtering and Common Mode Cap jumper configuration, All products ship with jumpers installed, code "J".

# Product Selection—480V PowerFlex 755TS Drives

480V AC, Three-phase Drives—IP00/IP20, NEMA/UL Type Open <sup>(1) (2)</sup>

Normal Duty			Heavy Duty				Cat. No. <sup>(3) (4) (5)</sup>	Frame Size	
Output Amps		Hp	Output Amps			Hp			
Cont.	1 min		3 s	Cont.	1 min				3 s
2.1	2.3	3.2	1	1.1	2.3	3.2	0.5	20G21RD2P1JAONNNNN	1
3.4	3.7	5.1	2	2.1	3.7	5.1	1	20G21RD3P4JAONNNNN	
5	5.5	7.5	3	3.4	5.5	7.5	2	20G21RD5P0JAONNNNN	
8	8.8	12	5	5	8.8	12	3	20G21RD8P0JAONNNNN	
11	12.1	16.5	7.5	8	12.1	16.5	5	20G21RD0T1JAONNNNN	
14	15.4	21	10	11	16.5	21	7.5	20G21RD014JAONNNNN	
2.1	3.1	3.7	1	1	3.1	3.7	1	20G21ND2P1JAONNNNN	
3.4	5.1	6.1	2	3.4	5.1	6.1	2	20G21ND3P4JAONNNNN	
5	7.5	9	3	5	7.5	9	3	20G21ND5P0JAONNNNN	
8	12	14.4	5	8	12	14.4	5	20G21ND8P0JAONNNNN	
11	16.5	19.8	7.5	11	16.5	19.8	7.5	20G21ND0T1JAONNNNN	
14	15.4	21	10	11	16.5	21	7.5	20G21ND014JAONNNNN	
22	24.2	33	15	14	21	33	10	20G21ND022JAONNNNN	3
27	29.7	40.5	20	22	33	40.5	15	20G21ND027JAONNNNN	
34	37.4	51	25	27	40.5	51	20	20G21ND034JAONNNNN	
40	44	60	30	34	51	61.2	25	20G21ND040JAONNNNN	
53	58.3	79.5	40	40	60	78	30	20G21ND053JAONNNNN	
52	57.2	78	40	40	60	78	30	20G21ND052JAONNNNN	
65	71.5	97.5	50	52	78	97.5	40	20G21ND065JAONNNNN	
78	85.8	117	60	65	97.5	117	50	20G21ND078JAONNNNN	
77	84.7	115.5	60	65	97.5	117	50	20G21ND077JAONNNNN	5
96	105.6	144	75	77	115.5	144	60	20G21ND096JAONNNNN	
125	137.5	187.5	100	96	144	187.5	75	20G2AND125JAONNNNN <sup>(6)</sup>	6
156	171.6	234	125	125	187.5	234	100	20G2AND156JAONNNNN <sup>(6)</sup>	
186	204.6	279	150	156	234	280.8	125	20G2AND186JAONNNNN <sup>(6)</sup>	
248	272.8	372	200	186	279	372	150	20G2AND248JAONNNNN <sup>(6)</sup>	
302	332.2	453	250	248	372	453	200	20G2AND302JAONNNNN <sup>(6)</sup>	7
361	397.1	541.5	300	302	453	543.6	250	20G2AND361JAONNNNN <sup>(6)</sup>	
415	456.5	622.5	350	361	541.5	649.8	300	20G2AND415JAONNNNN <sup>(6)</sup>	
477	524.7	715.5	400	361	541.5	649.8	300	20G2AND477JAONNNNN <sup>(6)</sup>	

- (1) Frames 1..5 are IP20, NEMA/UL Type Open. Frames 6...7 are IP00, NEMA/UL Type Open. Frames 1...7 can be converted to IP20, NEMA/UL Type 1 with optional kit (20-750-NEMA1-Fn), where n is the frame size of the drive.
- (2) Frames 2...7 IP20/IP00, NEMA/UL Type Open drives can be converted to a flange mount drive (back/heatsink: IP66, NEMA/UL Type 4X) with an optional user-installed flange-mount adapter kit (20-750-TFLNG1-Fn), where n is the frame size of the drive.
- (3) The 4th character determines corrosive gas protection; "2" = standard protection, and "E" = corrosive gas protection (XT).
- (4) The 5th character determines Input Type; "T" = AC input with precharge and DC terminals for frames 1..5, "4" = DC input with precharge for frames 5...7, and "A" = AC input with precharge and no DC terminals for frames 6 and 7. For DC input drives, see [PFLX-S6002](#), the PowerFlex Low Voltage Drives Selection Guide.
- (5) The 11th character indicates the default Filtering and Common Mode Cap jumper configuration. All products ship with jumpers installed, code "J".
- (6) The 12th character determines whether an internal dynamic braking IGBT is included; "A" = Internal dynamic braking transistor installed, and "N" = No internal dynamic braking transistor.

## 480V AC, Three-phase Drives—IP54, NEMA/UL Type 12

Normal Duty				Heavy Duty				Cat. No. <sup>(1) (2) (3)</sup>	Frame Size
Output Amps			Hp	Output Amps			Hp		
Cont.	1 min	3 s		Cont.	1 min	3 s			
2.1	3.1	3.7	1	2.1	3.1	3.7	1	20G21GD2P1JA0NNNNN	2
3.4	5.1	6.1	2	3.4	5.1	6.1	1	20G21GD3P4JA0NNNNN	
5	5.5	7.5	3	3.4	5.1	6.1	2	20G21GD5P0JA0NNNNN	
8	12	14.4	5	8	12	14.4	5	20G21GD8P0JA0NNNNN	
11	16.5	19.8	7.5	11	16.5	19.8	7.5	20G21GD011JA0NNNNN	
14	15.4	21	10	11	16.5	21	7.5	20G21GD014JA0NNNNN	
22	24.2	33	15	14	21	33	10	20G21GD022JA0NNNNN	
27	29.7	40.5	20	22	33	40.5	15	20G21GD027JA0NNNNN	3
34	37.4	51	25	27	40.5	51	20	20G21GD034JA0NNNNN	
40	44	60	30	34	51	61.2	25	20G21GD040JA0NNNNN	
52	57.2	78	40	40	60	78	30	20G21GD052JA0NNNNN	4
66	72.5	99	50	52	78	97.5	40	20G21GD066JA0NNNNN	
65	71.5	97.5	50	52	78	97.5	40	20G21GD065JA0NNNNN	5
77	84.7	115.5	60	65	97.5	117	50	20G21GD077JA0NNNNN	
96	105.6	144	75	77	115.5	144	60	20G2AGD096JA0NNNNN <sup>(4)</sup>	6
125	137.5	187.5	100	96	144	187.5	75	20G2AGD125JA0NNNNN <sup>(4)</sup>	
156	171.6	234	125	125	187.5	234	100	20G2AGD156JA0NNNNN <sup>(4)</sup>	
186	204.6	279	150	156	234	280.8	125	20G2AGD186JA0NNNNN <sup>(4)</sup>	
248	272.8	372	200	186	279	372	150	20G2AGD248JA0NNNNN <sup>(4)</sup>	7
302	332.2	453	250	248	372	453	200	20G2AGD302JA0NNNNN <sup>(4)</sup>	
361	397.1	541.5	300	302	453	543.6	250	20G2AGD361JA0NNNNN <sup>(4)</sup>	
415	456.5	622.5	350	361	541.5	649.8	300	20G2AGD415JA0NNNNN <sup>(4)</sup>	

- (1) The 4th character determines corrosive gas protection; "2" = standard protection, and "E" = corrosive gas protection (XT).
- (2) The 5th character determines Input Type; "1" = AC input with precharge and DC terminals for frames 1..5, "4" = DC input with precharge and no DC terminals for frames 6 and 7. For DC input drives, see [PFLEX-S6002](#), the PowerFlex Low Voltage Drives Selection Guide.
- (3) The 11th character indicates the default Filtering and Common Mode Cap jumper configuration. All products ship with jumpers installed, code "J".
- (4) The 12th character determines whether an internal dynamic braking IGBT is included; "A" = Internal dynamic braking transistor installed, and "N" = No internal dynamic braking transistor.

**480V AC, Three-phase Drives—Flange Mount (Front: IP20, NEMA/UL Type Open; Back/Heatsink: IP66, NEMA/UL Type 4X)**

Normal Duty				Heavy Duty				Cat. No. (1) (2) (3)	Frame Size
Output Amps			Hp	Output Amps			Hp		
Cont.	1 min	3 s		Cont.	1 min	3 s			
2.1	3.1	3.7	1	2.1	3.1	3.7	1	20G21FD2P1JA0NNNNN	2
3.4	5.1	6.1	2	3.4	5.1	6.1	2	20G21FD3P4JA0NNNNN	
5	7.5	9	3	5	7.5	9	3	20G21FD5P0JA0NNNNN	
8	12	14.4	5	8	12	14.4	5	20G21FD8P0JA0NNNNN	
11	16.5	19.8	7.5	11	16.5	19.8	7.5	20G21FD011JA0NNNNN	
14	15.4	21	10	11	16.5	21	7.5	20G21FD014JA0NNNNN	
22	24.2	33	15	14	21	33	10	20G21FD022JA0NNNNN	
27	29.7	40.5	20	22	33	40.5	15	20G21FD027JA0NNNNN	3
34	37.4	51	25	27	40.5	51	20	20G21FD034JA0NNNNN	
40	44	60	30	34	51	61.2	25	20G21FD040JA0NNNNN	
52	57.2	78	40	40	60	78	30	20G21FD052JA0NNNNN	4
65	71.5	97.5	50	52	78	97.5	40	20G21FD065JA0NNNNN	
78	85.8	117	60	65	97.5	117	50	20G21FD078JA0NNNNN	
77	84.7	115.5	60	65	97.5	117	50	20G21FD077JA0NNNNN	5
96	105.6	144	75	77	115.5	144	60	20G21FD096JA0NNNNN	

- (1) The 4th character determines corrosive gas protection; "2" = standard protection, and "E" = corrosive gas protection (XT).
- (2) The 5th character determines Input Type; "1" = AC input with precharge and DC terminals for frames 1...5, "4" = DC input with precharge for frames 5...7, and "A" = AC input with precharge and no DC terminals for frames 6 and 7. For DC input drives, see [PFLX-S6002](#), the PowerFlex Low Voltage Drives Selection Guide.
- (3) The 11th character determines default Filtering and Common Mode Cap jumper configuration; "J" = Installed, and "A" = Removed.

# Product Selection—575...600V PowerFlex 755TS Drives

Frames 3, 4, and 5 are only 575...600V AC drives. Frames 6 and 7 are dual-voltage drives, and can be operated at 575...600V or 660...690V AC. See [Product Selection—660...690V PowerFlex 755TS Drives on page 20](#).

**IMPORTANT** When frames 3, 4, and 5 are used in common DC input-sharing applications with frame 6 or larger drives, set the overvoltage for the frame 6 or larger drives to the value that corresponds with a 600V AC input.

## 575...600V AC, Three-phase Drives—IP00/IP20, NEMA/UL Type Open <sup>(1) (2)</sup>

Normal Duty				Heavy Duty				Cat. No. <sup>(3) (4) (5)</sup>	Frame Size
Output Amps			Hp	Output Amps			Hp		
Cont.	1 min	3 s		Cont.	1 min	3 s			
1.7	1.9	2.6	1	1.7	1.4	2.6	1	20G21NE1P7JAONNNNN	3
2.7	3	4.1	2	1.7	2.6	4.1	1	20G21NE2P7JAONNNNN	
3.9	4.29	5.85	3	2.7	4.1	5.9	2	20G21NE3P9JAONNNNN	
6.1	6.7	9.2	5	3.9	5.9	9.2	3	20G21NE6P1JAONNNNN	
9	9.9	13.5	7.5	6.1	9.2	13.5	5	20G21NE9POJAONNNNN	
11	12.1	16.5	10	9	13.5	16.5	7.5	20G21NE011JAONNNNN	
17	18.7	25.5	15	11	16.5	25.5	10	20G21NE017JAONNNNN	
22	24.2	33	20	17	25.5	33	15	20G21NE022JAONNNNN	4
27	29.7	40.5	25	22	33	40.5	20	20G21NE027JAONNNNN	
32	35.2	48	30	27	40.5	48.6	25	20G21NE032JAONNNNN	
41	45.1	61.5	40	32	48	61.5	30	20G21NE041JAONNNNN	5
52	57.2	78	50	41	61.5	78	40	20G21NE052JAONNNNN	
12	13.2	18	10	9.1	13.7	18	7.5	20G2ANE012JAONNNNN <sup>(6)</sup>	6
18	19.8	27	15	12	18	27	10	20G2ANE018JAONNNNN <sup>(6)</sup>	
23	25.3	34.5	20	18	27	34.5	15	20G2ANE023JAONNNNN <sup>(6)</sup>	
24	26.4	36	20	22	33	39.6	20	20G2ANE024JAONNNNN <sup>(6)</sup>	
28	30.8	42	25	23	34.5	42	20	20G2ANE028JAONNNNN <sup>(6)</sup>	
33	36.3	49.5	30	28	42	50.4	25	20G2ANE033JAONNNNN <sup>(6)</sup>	
42	46.2	63	40	33	49.5	63	30	20G2ANE042JAONNNNN <sup>(6)</sup>	
53	58	80	50	42	63	80	40	20G2ANE053JAONNNNN <sup>(6)</sup>	
63	69	95	60	52	78	95	50	20G2ANE063JAONNNNN <sup>(6)</sup>	
77	85	116	75	63	95	116	60	20G2ANE077JAONNNNN <sup>(6)</sup>	
99	109	149	100	77	116	149	75	20G2ANE099JAONNNNN <sup>(6)</sup>	7
125	138	188	125	99	149	188	100	20G2ANE125JAONNNNN <sup>(6)</sup>	
144	158	216	150	125	188	225	125	20G2ANE144JAONNNNN <sup>(6)</sup>	
192	211	288	200	144	216	288	150	20G2ANE192JAONNNNN <sup>(6)</sup>	
242	266	363	250	192	288	363	200	20G2ANE242JAONNNNN <sup>(6)</sup>	
289	318	434	300	242	363	436	250	20G2ANE289JAONNNNN <sup>(6)</sup>	

- (1) Frames 3...5 are IP20, NEMA/UL Type Open. Frames 6...7 are IP00, NEMA/UL Type Open. Frames 3...7 can be converted to IP20, NEMA/UL Type 1 with optional kit (20-750-NEMA1-Fn), where *n* is the frame size of the drive.
- (2) Frames 2...7 IP20/IP00, NEMA/UL Type Open drives can be converted to a flange mount drive (back/heatsink: IP66, NEMA/UL Type 4X) with an optional user-installed flange-mount adapter kit (20-750-TFLNG1-Fn), where *n* is the frame size of the drive.
- (3) The 4th character determines corrosive gas protection; "2" = standard protection, and "E" = corrosive gas protection (XT).
- (4) The 5th character determines Input Type; "1" = AC input with precharge and DC terminals for frames 1...5, "4" = DC input with precharge for frames 5...7, and "A" = AC input with precharge and no DC terminals for frames 6 and 7. For DC input drives, see [PFLX-SG002](#), the PowerFlex Low Voltage Drives Selection Guide.
- (5) The 11th character indicates the default Filtering and Common Mode Cap jumper configuration. All products ship with jumpers installed, code "J".
- (6) The 12th character determines whether an internal dynamic braking IGBT is included; "A" = internal dynamic braking transistor installed, and "N" = No internal dynamic braking transistor.

Frames 3, 4, and 5 are only 575...600V AC drives. Frames 6 and 7 are dual-voltage drives, and can be operated at 575...600V or 660...690V AC. See [Product Selection—660...690V PowerFlex 755TS Drives on page 20](#).

**IMPORTANT** When frames 3, 4, and 5 are used in common DC input-sharing applications with frame 6 or larger drives, set the overvoltage for the frame 6 or larger drives to the value that corresponds with a 600V AC input.

**575...600V AC, Three-phase Drives—IP54, NEMA/UL Type 12**

Normal Duty				Heavy Duty				Cat. No. (1) (2) (3)	Frame Size
Output Amps			Hp	Output Amps			Hp		
Cont.	1 min	3 s		Cont.	1 min	3 s			
1.7	1.9	2.6	1	1.7	1.4	2.6	1	20G21GE1P7JA0NNNNN	3
2.7	3	4.1	2	1.7	2.6	4.1	1	20G21GE2P7JA0NNNNN	
3.9	4.29	5.85	3	2.7	4.1	5.9	2	20G21GE3P9JA0NNNNN	
6.1	6.7	9.2	5	3.9	5.9	9.2	3	20G21GE6P1JA0NNNNN	
9	9.9	13.5	7.5	6.1	9.2	13.5	5	20G21GE9P0JA0NNNNN	
11	12.1	16.5	10	9	13.5	16.5	7.5	20G21GE0T1JA0NNNNN	
17	18.7	25.5	15	11	16.5	25.5	10	20G21GE017JA0NNNNN	
22	24.2	33	20	17	25.5	33	15	20G21GE022JA0NNNNN	
27	29.7	40.5	25	22	33	40.5	20	20G21GE027JA0NNNNN	4
32	35.2	48	30	27	40.5	48.6	25	20G21GE032JA0NNNNN	
41	45.1	61.5	40	32	48	61.5	30	20G21GE041JA0NNNNN	5
12	13.2	18	10	9.1	13.7	18	7.5	20G2AGE012JA0NNNNN <sup>(4)</sup>	6
18	19.8	27	15	12	18	27	10	20G2AGE018JA0NNNNN <sup>(6)</sup>	
23	25.3	34.5	20	18	27	34.5	15	20G2AGE023JA0NNNNN <sup>(6)</sup>	
24	26.4	36	20	22	33	39.6	20	20G2AGE024JA0NNNNN <sup>(6)</sup>	
28	30.8	42	25	23	34.5	42	20	20G2AGE028JA0NNNNN <sup>(6)</sup>	
33	36.3	49.5	30	28	42	50.4	25	20G2AGE033JA0NNNNN <sup>(6)</sup>	
42	46.2	63	40	33	49.5	63	30	20G2AGE042JA0NNNNN <sup>(6)</sup>	
53	58	80	50	42	63	80	40	20G2AGE053JA0NNNNN <sup>(6)</sup>	
63	69	95	60	52	78	95	50	20G2AGE063JA0NNNNN <sup>(6)</sup>	7
77	85	116	75	63	95	116	60	20G2AGE077JA0NNNNN <sup>(6)</sup>	
99	109	149	100	77	116	149	75	20G2AGE099JA0NNNNN <sup>(6)</sup>	
125	138	188	125	99	149	188	100	20G2AGE125JA0NNNNN <sup>(6)</sup>	
144	158	216	150	125	188	225	125	20G2AGE144JA0NNNNN <sup>(6)</sup>	
192	211	288	200	144	216	288	150	20G2AGE192JA0NNNNN <sup>(6)</sup>	
242	266	363	250	192	288	363	200	20G2AGE242JA0NNNNN <sup>(6)</sup>	
289	318	434	300	242	363	436	250	20G2AGE289JA0NNNNN <sup>(6)</sup>	

- (1) The 4th character determines corrosive gas protection; "2" = standard protection, and "E" = corrosive gas protection (XT).
- (2) The 5th character determines Input Type; "1" = AC input with precharge and DC terminals for frames 1...5, "4" = DC input with precharge for frames 5...7, and "A" = AC input with precharge and no DC terminals for frames 6 and 7. For DC input drives, see [PFLEX-SG002](#), the PowerFlex Low Voltage Drives Selection Guide.
- (3) The 11th character indicates the default Filtering and Common Mode Cap jumper configuration. All products ship with jumpers installed, code "J".
- (4) The 12th character determines whether an internal dynamic braking IGBT is included; "A" = internal dynamic braking transistor installed, and "N" = No internal dynamic braking transistor.

**600V AC, Three-phase Drives—Flange Mount (Front: IP20, NEMA/UL Type Open; Back/Heatsink: IP66, NEMA/UL Type 4X)**

Normal Duty				Heavy Duty				Cat. No. (1) (2)	Frame Size
Output Amps			Hp	Output Amps			Hp		
Cont.	1 min	3 s		Cont.	1 min	3 s			
1.7	1.9	2.6	1	1.7	1.4	2.6	1	20G21FE1P7JA0NNNNN	3
2.7	3	4.1	2	1.7	2.6	4.1	1	20G21FE2P7JA0NNNNN	
3.9	4.29	5.85	3	2.7	4.1	5.9	2	20G21FE3P9JA0NNNNN	
6.1	6.7	9.2	5	3.9	5.9	9.2	3	20G21FE6P1JA0NNNNN	
9	9.9	13.5	7.5	6.1	9.2	13.5	5	20G21FE9P0JA0NNNNN	
11	12.1	16.5	10	9	13.5	16.5	7.5	20G21FE011JA0NNNNN	
17	18.7	25.5	15	11	16.5	25.5	10	20G21FE017JA0NNNNN	
22	24.2	33	20	17	25.5	33	15	20G21FE022JA0NNNNN	
27	29.7	40.5	25	22	33	40.5	20	20G21FE027JA0NNNNN	4
32	35.2	48	30	27	40.5	48.6	25	20G21FE032JA0NNNNN	
41	45.1	61.5	40	32	48	61.5	30	20G21FE041JA0NNNNN	5
52	57.2	78	50	41	61.5	78	40	20G21FE052JA0NNNNN	

- (1) The 5th character determines Input Type; "1" = AC input with precharge and DC terminals for frames 1...5, "4" = DC input with precharge for frames 5...7, and "A" = AC input with precharge and no DC terminals for frames 6 and 7. For DC input drives, see [PFLEX-S6002](#), the PowerFlex Low Voltage Drives Selection Guide.
- (2) The 11th character indicates the default Filtering and Common Mode Cap jumper configuration, All products ship with jumpers installed, code "J".

# Product Selection—660...690V PowerFlex 755TS Drives

660...690V AC, Three-phase Drives—IP00/IP20, NEMA/UL Type Open <sup>(1) (2)</sup>

Normal Duty				Heavy Duty				Cat. No. <sup>(3) (4) (5)</sup>	Frame Size
Output Amps			kW	Output Amps			kW		
Cont.	1 min	3 s		Cont.	1 min	3 s			
12	13.2	18	7.5	9	13.5	18	5.5	20G2ANF012JA0NNNNN <sup>(6)</sup>	6
15	16.5	22.5	11	12	18	22.5	7.5	20G2ANF015JA0NNNNN <sup>(6)</sup>	
20	22	30	15	15	22.5	30	11	20G2ANF020JA0NNNNN <sup>(6)</sup>	
23	25.3	34.5	18.5	20	30	36	15	20G2ANF023JA0NNNNN <sup>(6)</sup>	
30	33	45	22	23	34.5	45	18.5	20G2ANF030JA0NNNNN <sup>(6)</sup>	
34	37.4	51	30	30	45	54	22	20G2ANF034JA0NNNNN <sup>(6)</sup>	
46	40.6	69	37	34	51	69	30	20G2ANF046JA0NNNNN <sup>(6)</sup>	
50	55	75	45	46	69	83	37	20G2ANF050JA0NNNNN <sup>(6)</sup>	
61	67	92	55	50	75	92	45	20G2ANF061JA0NNNNN <sup>(6)</sup>	
82	90	123	75	61	92	123	55	20G2ANF082JA0NNNNN <sup>(6)</sup>	
98	108	147	90	82	123	148	75	20G2ANF098JA0NNNNN <sup>(6)</sup>	
119	131	179	110	98	147	179	90	20G2ANF119JA0NNNNN <sup>(6)</sup>	
142	156	213	132	119	179	214	110	20G2ANF142JA0NNNNN <sup>(6)</sup>	
171	188	257	160	142	213	257	132	20G2ANF171JA0NNNNN <sup>(6)</sup>	
212	233	318	200	171	257	318	160	20G2ANF212JA0NNNNN <sup>(6)</sup>	
263	289	395	250	212	318	395	200	20G2ANF263JA0NNNNN <sup>(6)</sup>	

- (1) Frames 1...5 are IP20, NEMA/UL Type Open. Frames 6...7 are IP00, NEMA/UL Type Open. Frames 1...7 can be converted to IP20, NEMA/UL Type 1 with optional kit (20-750-NEMA1-Fn), where n is the frame size of the drive.
- (2) Frames 2...7 IP20/IP00, NEMA/UL Type Open drives can be converted to a flange mount drive (back/heatsink: IP66, NEMA/UL Type 4X) with an optional user-installed flange-mount adapter kit (20-750-TFLNG1-Fn), where n is the frame size of the drive.
- (3) The 4th character determines corrosive gas protection; "2" = standard protection, and "E" = corrosive gas protection (XT).
- (4) The 5th character determines Input Type; "1" = AC input with precharge and DC terminals for frames 1...5, "4" = DC input with precharge for frames 5...7, and "A" = AC input with precharge and no DC terminals for frames 6 and 7. For DC input drives, see [PFLEX-S6002](#), the PowerFlex Low Voltage Drives Selection Guide.
- (5) The 11th character indicates the default Filtering and Common Mode Cap jumper configuration. All products ship with jumpers installed, code "J".
- (6) The 12th character determines whether an internal dynamic braking IGBT is included; "A" = Internal dynamic braking transistor installed, and "N" = No internal dynamic braking transistor.

## 660...690V AC, Three-phase Drives—IP54, NEMA/UL Type 12

Normal Duty				Heavy Duty				Cat. No. <sup>(1)</sup> <sup>(2)</sup> <sup>(3)</sup>	Frame Size
Output Amps			kW	Output Amps			kW		
Cont.	1 min	3 s		Cont.	1 min	3 s			
12	13.2	18	7.5	9	13.5	18	5.5	20G2AGE012JA0NNNNN <sup>(4)</sup>	6
15	16.5	22.5	11	12	18	22.5	7.5	20G2AGE015JA0NNNNN <sup>(6)</sup>	
20	22	30	15	15	22.5	30	11	20G2AGE020JA0NNNNN <sup>(6)</sup>	
23	25.3	34.5	18.5	20	30	36	15	20G2AGE023JA0NNNNN <sup>(6)</sup>	
30	33	45	22	23	34.5	45	18.5	20G2AGE030JA0NNNNN <sup>(6)</sup>	
34	37.4	51	30	30	45	54	22	20G2AGE034JA0NNNNN <sup>(6)</sup>	
46	40.6	69	37	34	51	69	30	20G2AGE046JA0NNNNN <sup>(6)</sup>	
50	55	75	45	46	69	83	37	20G2AGE050JA0NNNNN <sup>(6)</sup>	
61	67	92	55	50	75	92	45	20G2AGE061JA0NNNNN <sup>(6)</sup>	
82	90	123	75	61	92	123	55	20G2AGE082JA0NNNNN <sup>(6)</sup>	
98	108	147	90	82	123	148	75	20G2AGE098JA0NNNNN <sup>(6)</sup>	
119	131	179	110	98	147	179	90	20G2AGE119JA0NNNNN <sup>(6)</sup>	
142	156	213	132	119	179	214	110	20G2AGE142JA0NNNNN <sup>(6)</sup>	
171	188	257	160	142	213	257	132	20G2AGE171JA0NNNNN <sup>(6)</sup>	7
212	233	318	200	171	257	318	160	20G2AGE212JA0NNNNN <sup>(6)</sup>	
263	289	395	250	212	318	395	200	20G2AGE263JA0NNNNN <sup>(6)</sup>	

(1) The 4th character determines corrosive gas protection; "2" = standard protection, and "E" = corrosive gas protection (XT).

(2) The 5th character determines Input Type; "1" = AC input with precharge and DC terminals for frames 1...5, "4" = DC input with precharge and no DC terminals for frames 6 and 7. For DC input drives, see [PFLX-S6002](#), the PowerFlex Low Voltage Drives Selection Guide.

(3) The 11th character indicates the default Filtering and Common Mode Cap jumper configuration. All products ship with jumpers installed, code "J".

(4) The 12th character determines whether an internal dynamic braking IGBT is included; "A" = Internal dynamic braking transistor installed, and "N" = No internal dynamic braking transistor.

## 660...690V AC, Three-phase Drives—IP54, NEMA/UL Type 12



Frame 6...7 IP00, NEMA Type Open drives can be converted to a flange mount drive (Back/Heatsink: IP66, NEMA/UL Type 4X) with an optional user installed flange kit (kit 20-750-TFLNG1-F6 for Frame 6, and kit 20-750-TFLNG1-F7 for Frame 7).

## Certifications and Specifications

This section provides information for certifications and specifications.

### Certifications

Certification	Description
Product certifications	Rockwell Automation maintains current product certification information on its website at: <a href="http://rok.auto/certifications">rok.auto/certifications</a>
CE	In conformity with these European Directives EMC Directive (2014/30/EU) EN 61800-3 Low Voltage Directive (2014/35/EU) EN 61800-5-1 ATEX Directive (2014/34/EU) EC-Type-Examination Certificate Number TÜV 12 ATEX 7990 X EN 50495
cULus	Listed to UL61800-5-1 and CSA C22.2 No. 274 up to 600V AC
EAC	Low Voltage TP TC 004/2011 EMC TP TC 020/2011
Ecodesign	Ecodesign Directive (2009/125/EC) as implemented by EU 2019/1781.
EMC	In conformity with EMC Directive (2014/30/EU).
Functional Safety	TÜV Rheinland – Certification applies to 20-750-S, 20-750-S1, 20-750-S3, and 20-750-S4 Safety Options when installed in drive. Standards applied EN 61800-3, EN 61508 PARTS 1-7 EN 61800-5-1, EN 62061 EN 61800-5-2, EN 60204-1 EN ISO 13849-1
KCC	R-R-RAA-Drive, R-R-RAA-750-M See the certificate of registration for specific drive catalog numbers that have this certification. <sup>(1)</sup>
Morocco	Arrêté ministériel n° 6404-15 du 1 er muharram 1437 (15 octobre 2015) NM EN 61800-5-1 Arrêté ministériel n° 6404-15 du 29 ramadan 1436 (16 juillet 2015) NM EN 61800-3
RCM	Australian Communications and Media Authority In conformity with the following items Radiocommunications Act: 1992 (including Amendments up to 2018) Radiocommunications (Electromagnetic Compatibility) Standard 2017 Radiocommunications Labeling (Electromagnetic Compatibility) Notice 2017 Standards applied EN 61800-3
SEMI F47	Certified compliant with the following standards SEMI F47 IEC 61000-4-34
UKCA	2016 No. 1101 Electrical Equipment (Safety) Regulations (LV) 2016 No. 1091 Electromagnetic Compatibility Regulations (EMC) 2012 No. 3032 Restriction of the Use of Certain Hazardous Substances in Electrical and Electronic Equipment Regulations (RoHS)

(1) See the product certifications website, [rok.auto/certifications](http://rok.auto/certifications), for declarations of conformity, certificates, and other certification details.

## Environmental Specifications

Category	Specification																																											
Altitude Based on load  Based on voltage	<p>See derating guidelines starting on <a href="#">page 35</a>.</p> <p>Based on EN61800-5-1 (Electro-thermal Safety Standard for drives)</p> <table border="1"> <thead> <tr> <th rowspan="2">System and Ground Configuration</th> <th rowspan="2">Overvoltage Category <sup>(3)</sup></th> <th colspan="4">Altitude Limit Above Sea Level [m (ft)] <sup>(4)(5)</sup></th> </tr> <tr> <th>208/240V AC</th> <th>400/480V AC</th> <th>600V AC</th> <th>690V AC</th> </tr> </thead> <tbody> <tr> <td rowspan="2">Center grounded (Y neutral) (TN or TT) <sup>(1)</sup></td> <td>Category II</td> <td>9000 (29,527.5) <sup>(6)</sup></td> <td>9000 (29,527.5) <sup>(6)</sup></td> <td>7500 (24,606.3) <sup>(6)</sup></td> <td>7500 (24,606.3) <sup>(6)</sup></td> </tr> <tr> <td>Category III</td> <td>9000 (29,527.5) <sup>(6)</sup></td> <td>4800 (15,748.0)</td> <td>4800 (15,748.0)</td> <td>4800 (15,748.0)</td> </tr> <tr> <td rowspan="2">Ungrounded or impedance ground <sup>(2)</sup> (IT) <sup>(1)</sup></td> <td>Category II</td> <td>9000 (29,527.5) <sup>(6)</sup></td> <td>4800 (15,748.0)</td> <td>7500 (24,606.3) <sup>(6)</sup></td> <td>4800 (15,748.0)</td> </tr> <tr> <td>Category III</td> <td>4800 (15,748.0)</td> <td>2000 (6,561.7)</td> <td>4800 (15,748.0)</td> <td>2000 (6,561.7)</td> </tr> <tr> <td rowspan="2">Corner grounded (TN or TT) <sup>(2)</sup></td> <td>Category II</td> <td>9000 (29,527.5) <sup>(6)</sup></td> <td>4800 (15,748.0)</td> <td>7500 (24,606.3) <sup>(6)</sup></td> <td>4800 (15,748.0)</td> </tr> <tr> <td>Category III</td> <td>4800 (15,748.0)</td> <td>2000 (6,561.7)</td> <td>4800 (15,748.0)</td> <td>2000 (6,561.7)</td> </tr> </tbody> </table> <p>(1) IEC Standard 60364-1                      (2) Frame 1 drives do not support Category III ungrounded, impedance, or corner grounded distribution.                      (3) Category II (Isolation Transformer Level) - Typically two levels of isolation or protection from outdoor power lines. Category III (most common) Distribution Level Inside a Building - Typically one level of isolation or protection from outdoor power lines.                      (4) Excluding failure from cosmic radiation. Cosmic radiation increases rate of semiconductor malfunction at altitudes greater than 3000 m (9842.6 ft) above sea level. Concrete walls and ceilings or concrete walls and large bottles of water overhead are examples of ways to shield against cosmic radiation.                      (5) Frame 1 drives are limited to a maximum of 2000 m (6,561.7 ft) thermally. See <a href="#">Derating Guidelines on page 35</a>.                      (6) Drive is limited to a maximum of 4800 m (15,748.0 ft) thermally. See <a href="#">Derating Guidelines on page 35</a>.</p>	System and Ground Configuration	Overvoltage Category <sup>(3)</sup>	Altitude Limit Above Sea Level [m (ft)] <sup>(4)(5)</sup>				208/240V AC	400/480V AC	600V AC	690V AC	Center grounded (Y neutral) (TN or TT) <sup>(1)</sup>	Category II	9000 (29,527.5) <sup>(6)</sup>	9000 (29,527.5) <sup>(6)</sup>	7500 (24,606.3) <sup>(6)</sup>	7500 (24,606.3) <sup>(6)</sup>	Category III	9000 (29,527.5) <sup>(6)</sup>	4800 (15,748.0)	4800 (15,748.0)	4800 (15,748.0)	Ungrounded or impedance ground <sup>(2)</sup> (IT) <sup>(1)</sup>	Category II	9000 (29,527.5) <sup>(6)</sup>	4800 (15,748.0)	7500 (24,606.3) <sup>(6)</sup>	4800 (15,748.0)	Category III	4800 (15,748.0)	2000 (6,561.7)	4800 (15,748.0)	2000 (6,561.7)	Corner grounded (TN or TT) <sup>(2)</sup>	Category II	9000 (29,527.5) <sup>(6)</sup>	4800 (15,748.0)	7500 (24,606.3) <sup>(6)</sup>	4800 (15,748.0)	Category III	4800 (15,748.0)	2000 (6,561.7)	4800 (15,748.0)	2000 (6,561.7)
System and Ground Configuration	Overvoltage Category <sup>(3)</sup>			Altitude Limit Above Sea Level [m (ft)] <sup>(4)(5)</sup>																																								
		208/240V AC	400/480V AC	600V AC	690V AC																																							
Center grounded (Y neutral) (TN or TT) <sup>(1)</sup>	Category II	9000 (29,527.5) <sup>(6)</sup>	9000 (29,527.5) <sup>(6)</sup>	7500 (24,606.3) <sup>(6)</sup>	7500 (24,606.3) <sup>(6)</sup>																																							
	Category III	9000 (29,527.5) <sup>(6)</sup>	4800 (15,748.0)	4800 (15,748.0)	4800 (15,748.0)																																							
Ungrounded or impedance ground <sup>(2)</sup> (IT) <sup>(1)</sup>	Category II	9000 (29,527.5) <sup>(6)</sup>	4800 (15,748.0)	7500 (24,606.3) <sup>(6)</sup>	4800 (15,748.0)																																							
	Category III	4800 (15,748.0)	2000 (6,561.7)	4800 (15,748.0)	2000 (6,561.7)																																							
Corner grounded (TN or TT) <sup>(2)</sup>	Category II	9000 (29,527.5) <sup>(6)</sup>	4800 (15,748.0)	7500 (24,606.3) <sup>(6)</sup>	4800 (15,748.0)																																							
	Category III	4800 (15,748.0)	2000 (6,561.7)	4800 (15,748.0)	2000 (6,561.7)																																							
Corrosive atmosphere (Standard protection) IEC  ISA	<p>Conformity with IEC 60721-3-3, 3C3 and 3S2, for components manufactured by Rockwell Automation. A suitable IP54, NEMA/UL Type 12 Cabinet is required to meet the 3S2 requirement.</p> <p>Harsh environments with a copper or silver reactivity level greater than 1000 angstroms per 30 days exposure are not allowed.                      No condensation is allowed. Maximum allowable humidity is 60% in the presence of corrosive gases. See ISA-71.04-2013 for details on how to measure reactivity levels on copper and silver test coupons.</p>																																											
Corrosive atmosphere (Corrosive gas protection) <ul style="list-style-type: none"> <li>ASTM B845-97 Method K Accelerated Test (30-day Exposure)</li> <li>Rockwell Automation proprietary accelerated corrosion test for industries with sources of gaseous sulfur compounds, including tire and rubber</li> </ul>	<p>Severity Level GX per ANSI/ISA 71.03-2013, Airborne contaminants-gases. Severity level GX is defined as up to 2100 angstroms of film growth per 30 days of copper or silver reactivity.                      Severity Level CX per IEC 60721-3-3: 2019, Chemically Active Substances.                      For the product to meet the corrosive atmosphere rating, these conditions must be met:</p> <ul style="list-style-type: none"> <li>Protective covers must remain installed in unused connectors during storage and operation.</li> <li>The product or kit must be stored in the original packaging.</li> </ul>																																											

## Environmental Specifications (Continued)

Category	Specification																																																			
Surrounding Air Temperatures	<table border="1"> <thead> <tr> <th>Enclosure Rating</th> <th>Operating Range without Derating</th> <th>Maximum Operating Temperature with Derating (1)</th> <th>Frames</th> </tr> </thead> <tbody> <tr> <td colspan="4">Stand-alone/Wall-mount</td> </tr> <tr> <td>IP20, NEMA/UL Open Type</td> <td>-20...+50 °C (-4...+122 °F)</td> <td>60 °C (140 °F)</td> <td>1...5, All ratings</td> </tr> <tr> <td>IP00, NEMA/UL Open Type</td> <td>-20...+50 °C (-4...+122 °F)</td> <td>60 °C (140 °F)</td> <td>6 and 7, All ratings</td> </tr> <tr> <td>IP20, NEMA/UL Type 1 (with hood)</td> <td>-20...+40 °C (-4...+104 °F)</td> <td>50 °C (104 °F)</td> <td>1...5, All ratings</td> </tr> <tr> <td>IP20, NEMA/UL Type 1 (with option kit)</td> <td>-20...+40 °C (-4...+104 °F)</td> <td>50 °C (104 °F)</td> <td>6 and 7, All ratings</td> </tr> <tr> <td>IP54, NEMA/UL Type 12</td> <td>-20...+40 °C (-4...+104 °F)</td> <td>50 °C (104 °F)</td> <td>2...5, All ratings</td> </tr> <tr> <td colspan="4">Flange mount – front</td> </tr> <tr> <td>IP20, NEMA/UL Open Type</td> <td>-20...+50 °C (-4...+122 °F)</td> <td>60 °C (140 °F)</td> <td>2...5, All ratings</td> </tr> <tr> <td>IP00, NEMA/UL Open Type</td> <td>-20...+50 °C (-4...+122 °F)</td> <td>60 °C (140 °F)</td> <td>6 and 7, All ratings</td> </tr> <tr> <td colspan="4">Flange mount – back/heatsink</td> </tr> <tr> <td>IP66, NEMA/UL Type 4X/12</td> <td>-20...+40 °C (-4...+104 °F)</td> <td>50 °C (104 °F)</td> <td>2...5, All ratings (2)</td> </tr> </tbody> </table>				Enclosure Rating	Operating Range without Derating	Maximum Operating Temperature with Derating (1)	Frames	Stand-alone/Wall-mount				IP20, NEMA/UL Open Type	-20...+50 °C (-4...+122 °F)	60 °C (140 °F)	1...5, All ratings	IP00, NEMA/UL Open Type	-20...+50 °C (-4...+122 °F)	60 °C (140 °F)	6 and 7, All ratings	IP20, NEMA/UL Type 1 (with hood)	-20...+40 °C (-4...+104 °F)	50 °C (104 °F)	1...5, All ratings	IP20, NEMA/UL Type 1 (with option kit)	-20...+40 °C (-4...+104 °F)	50 °C (104 °F)	6 and 7, All ratings	IP54, NEMA/UL Type 12	-20...+40 °C (-4...+104 °F)	50 °C (104 °F)	2...5, All ratings	Flange mount – front				IP20, NEMA/UL Open Type	-20...+50 °C (-4...+122 °F)	60 °C (140 °F)	2...5, All ratings	IP00, NEMA/UL Open Type	-20...+50 °C (-4...+122 °F)	60 °C (140 °F)	6 and 7, All ratings	Flange mount – back/heatsink				IP66, NEMA/UL Type 4X/12	-20...+40 °C (-4...+104 °F)	50 °C (104 °F)	2...5, All ratings (2)
	Enclosure Rating	Operating Range without Derating	Maximum Operating Temperature with Derating (1)	Frames																																																
	Stand-alone/Wall-mount																																																			
	IP20, NEMA/UL Open Type	-20...+50 °C (-4...+122 °F)	60 °C (140 °F)	1...5, All ratings																																																
	IP00, NEMA/UL Open Type	-20...+50 °C (-4...+122 °F)	60 °C (140 °F)	6 and 7, All ratings																																																
	IP20, NEMA/UL Type 1 (with hood)	-20...+40 °C (-4...+104 °F)	50 °C (104 °F)	1...5, All ratings																																																
	IP20, NEMA/UL Type 1 (with option kit)	-20...+40 °C (-4...+104 °F)	50 °C (104 °F)	6 and 7, All ratings																																																
	IP54, NEMA/UL Type 12	-20...+40 °C (-4...+104 °F)	50 °C (104 °F)	2...5, All ratings																																																
	Flange mount – front																																																			
	IP20, NEMA/UL Open Type	-20...+50 °C (-4...+122 °F)	60 °C (140 °F)	2...5, All ratings																																																
	IP00, NEMA/UL Open Type	-20...+50 °C (-4...+122 °F)	60 °C (140 °F)	6 and 7, All ratings																																																
	Flange mount – back/heatsink																																																			
	IP66, NEMA/UL Type 4X/12	-20...+40 °C (-4...+104 °F)	50 °C (104 °F)	2...5, All ratings (2)																																																
	Storage temperature (all constructions)	-40...+70 °C (-40...+158 °F)																																																		
UV radiation	The HIM and IP54, NEMA/UL Type 12 drive plastics are not UV rated.																																																			
Relative humidity	<ul style="list-style-type: none"> <li>Standard protection</li> <li>Corrosive gas protection</li> </ul>																																																			
Shock – operating	Frames 1...6 Frame 7	15 g peak for 11 ms duration (±1.0 ms) 10 g peak for 11 ms duration (±1.0 ms)																																																		
Shock – packaged for shipment	Frames 1 and 2 Frames 3 and 4 Frame 5 Frames 6 and 7	381 mm (15 in.) drop height 330 mm (13 in.) drop height 305 mm (12 in.) drop height Meets International Safe Transit Association (ISTA) test procedure 2B																																																		
Vibration – operating	Frames 1 and 2 Frames 3...5 Frames 6 and 7	1.000 mm (0.040 in.) displacement, 2 g peak 1.000 mm (0.040 in.) displacement, 1.5 g peak 1.000 mm (0.040 in.) displacement, 1 g peak																																																		
Vibration – packaged for shipment, sinusoidal loose load	Frames 1...5 Frames 6 and 7	20.0 mm (0.8 in.) peak to peak, 2...5.186 Hz; 1.1 g peak from 5.186...20 Hz Meets ISTA 2B packaging standards																																																		
Vibration – packaged for shipment, random secured	Frames 1...5          Frames 6 and 7	Frequency (Hz) 1 4 16 40 80 200	PSD (g <sup>2</sup> /Hz) 0.00005 0.01 0.01 0.001 0.001 0.00001	Meets International Safe Transit Association (ISTA) test procedure 2B.																																																
Required airflow	Frame 1 and 2 3 4	Total fan airflow 84.95 m <sup>3</sup> /h (50 CFM) 135.92 m <sup>3</sup> /h (80 CFM) 543.68 m <sup>3</sup> /h (320 CFM)	Frame 5 6 7	Total fan airflow 883.49 m <sup>3</sup> /h (520 CFM) 856.30 m <sup>3</sup> /h (504 CFM) 1284.45 m <sup>3</sup> /h (756 CFM)																																																
Sound <b>IMPORTANT:</b> Sound pressure level is measured at 2 m (6.6 ft).	Frame 1 and 2 3 4	Sound level 63 dB 64 dB 72 dB	Frame 5 6 7	Sound level 77 dB 73 dB 74 dB																																																
Surrounding environment pollution degree Pollution Degree 1 and 2 Pollution Degree 3 and 4	All enclosures acceptable. Enclosure that meets or exceeds IP54, NEMA/UL Type 12 required.  See <a href="#">page 224</a> for descriptions of each pollution degree rating.																																																			

## Technical Specifications

Category	Specification	
Protection	<b>Motor Voltage</b>	
	<b>200/208V</b>	
	<b>240V</b>	
	<b>380/400V</b>	
	<b>480V</b>	
	<b>600V</b>	
	<b>690V</b>	
	AC input overvoltage trip	288V AC      288V AC      576V AC      576V AC      725V AC      825V AC
	AC input undervoltage trip	125V AC      150V AC      250V AC      300V AC      350V AC      400V AC
	Bus overvoltage trip	408V DC      408V DC      815V DC      815V DC      1026V DC      1172V DC
	Bus undervoltage shutoff	150V DC      150V DC      200V DC      200V DC      200V DC      200V DC
	Nominal bus voltage (full load)	281V DC      324V DC      540V DC      648V DC      810V DC      932V DC
	Drive overcurrent trip Software overcurrent trip Instantaneous current limit Hardware overcurrent trip	200% of drive rated 100% of 3 s rating (158...210%) 143% of 3 s rating (215...287%)
	Line transients	Up to 6000V peak per IEEE C62.41-1991
	Control logic noise immunity	Showering arc transients up to 1500V peak
Power ride-through	15 ms at full load	
Logic control ride-through	0.5 s min, 2 s typical	
Ground fault trip	Phase-to-ground on drive output	
Short circuit trip	Phase-to-phase on drive output	
Electrical	AC input voltage tolerance	See <a href="#">Input Voltage Tolerance on page 31</a> for full power and operating range.
	Frequency tolerance	47...63 Hz
	Input phases	Three-phase input provides full rating for all drives. For single-phase operation, see <a href="#">Single-Phase Drive Ratings on page 28</a> for rated current at 25 °C (77 °F) surrounding air temperature.
	DC input voltage tolerance	±10% of nominal bus voltage (see <a href="#">Nominal bus voltage (full load) on page 25</a> )
	Displacement power factor	0.98 across entire speed range
	DC link impedance	≤ 4%
	Efficiency	97.5% at rated amps, nominal line volts
	Maximum short circuit rating	100,000 A RMS symmetrical
	Actual short circuit rating	Determined by AIC rating of installed fuse/circuit breaker.
	Drive to motor power ratio Min Max	Recommended not less than 1:2 ratio Recommended not greater than 2:1 ratio
	Brake IGBT rating	100% of motor-rated torque
	Control POD current draw	5 A
	Digital inputs Nominal Maximum High state Low state	DC                      AC 24V DC              120V AC 30V DC              132V AC 20...24V DC      100...132V AC 0...5V DC           0...30V AC
	PTC inputs Standard Trip resistance Nominal resistance Reset resistance Short circuit trip resistance	22-Series I/O      ATEX option module for 11-Series I/O option module option module      IEC 6094-8 DIN 44082           3.2 kΩ 3.1 kΩ              1.6 kΩ 1.8 kΩ              N/A <sup>(1)</sup> 2.2 kΩ              100 Ω 80 Ω
		(1) No hysteresis, fault is latched.

## Technical Specifications (Continued)

Category	Specification	
Control	Method	Sine coded PWM with programmable carrier frequency. Ratings apply to all drives.
	Carrier frequency	Default settings Frames 1...3    4 kHz Frames 4...7    2 kHz Settings Frames 1...6    2, 4, 8, and 12 kHz Frame 7        2, 4, and 8 kHz
	Output voltage range	0 to rated motor voltage
	Output frequency range	0...325 Hz at 2 kHz carrier 0...590 Hz at 4 kHz carrier
	Frequency accuracy Digital input Analog input	Within $\pm 0.01\%$ of set output frequency Within $\pm 0.4\%$ of maximum output frequency
	Frequency control	Speed regulation – with slip compensation (V/Hz and Sensorless Vector modes) 0.5% of base speed across 40:1 speed range, 40:1 operating range
	Speed control	Without feedback (Flux Vector mode), 0.1% of base speed across 120:1 speed range, 120:1 operating range
		With feedback (Flux Vector mode), 0.001% of base speed across 120:1 speed range, 1000:1 operating range
	Torque accuracy	1.2% motor rated torque with encoder feedback and optional torque accuracy module, Cat. No. 20-750-TSTAM-CD-XT
	Selectable motor control	<ul style="list-style-type: none"> <li>Flux vector (with and without encoder feedback) for induction motors, surface permanent magnet (SPM) motors, and Interior permanent magnet (IPM) motors.</li> <li>Sensorless vector for induction motors, permanent magnet motors (both IPM and SPM), and synchronous reluctance motors.</li> <li>Volts per hertz for induction motors, permanent magnet motors (both IPM and SPM), and synchronous reluctance motors.</li> <li>Economizer for induction motors.</li> </ul>
	Stop modes	Multiple programmable stop modes including: Ramp, Coast, DC-Brake, Ramp-to-Hold, Fast Braking, and Current Limit Stop.
	Accel/Decel	Two independently programmable accel and decel times. Each time can be programmed from 0...3600 seconds in 0.1 second increments (0 to motor nameplate speed).
	S-curve time	Adjustable from 0...100% of ramp time (normal duty rating)
	Intermittent overload	Normal duty
Heavy duty		150% overload capability for up to 1 minute out of 10 minutes 180% overload capability for up to 3 seconds out of 60 seconds
Current limit capability	Proactive current limit programmable from 20...160% of rated output current. Independently programmable proportional and integral gain.	
Electronic motor overload protection	Class 1 to class 60 motor overload protection according to NEC article 430 and motor over-temperature protection according to NEC article 430.126 (A) (2). UL File E59272.	

# RF Emission Compliance and Installation Requirements

## PowerFlex 755TS 208V/240V and 400V/480V Input Drives

Drive Frame Catalog Number	EN 61800-3 Category C3 <sup>(1)</sup> <sup>(2)</sup> (I ≤ 100 A) CISPR11 Group 1 Class A (Input Power > 20 kVA)	EN 61800-3 Category C3 <sup>(1)</sup> <sup>(2)</sup> I > 100 A
Frame 1 20G...B2P2 through 20G...B015 20G...C2P1 through 20G...C015 20G...D2P1 through 20G...D014	150 m (492.1 ft) motor cable limit with no filter. Requires installation of the supplied C3 bracket to ground the motor cable shield.	N/A
Frame 2 20G...B2P2 through 20G...B022 20G...C2P1 through 20G...C022 20G...D2P1 through 20G...D022	150 m (492.1 ft) motor cable limit with no filter. Requires using the factory installed C3 bracket to ground the motor cable shield.	N/A
Frame 3 20G...B028 through 20G...B055 20G...C030 through 20G...C061 20G...D027 through 20G...D053	150 m (492.1 ft) motor cable limit with no filter. Requires using the factory installed C3 bracket to ground the motor cable shield.	N/A
Frame 4 20G...B054 through 20G...B071 20G...C060 through 20G...C086 20G...D052 through 20G...D078	150 m (492.1 ft) motor cable limit with no filter. Requires using the factory installed C3 bracket to ground the motor cable shield.	N/A
Frame 5 20G...B070 through 20G...B080 20G...C085 through 20G...C104 20G...D077 through 20G...D096	150 m (492.1 ft) motor cable limit with no filter. Requires using the factory installed C3 bracket to ground the motor cable shield.	150 m (492.1 ft) motor cable limit with no filter. Requires using the factory installed C3 bracket to ground the motor cable shield.
Frame 6 20G...B080 through 20G...B260 20G...C104 through 20G...C260 20G...D125 through 20G...D248	150 m (492.1 ft) motor cable limit with no filter. Requires a 20-750-EMC6-F6 EMC C3 option kit or other means of shield termination within the installation.	150 m (492.1 ft) motor cable limit with no filter. Requires a 20-750-EMC6-F6 EMC C3 option kit or other means of shield termination within the installation.
Frame 7 20G...B260 through 20G...B477 20G...C302 through 20G...C477 20G...D302 through 20G...D477	N/A	150 m (492.1 ft) motor cable limit with no filter. Requires a 20-750-EMC6-F7 EMC C3 option kit or other means of shield termination within the installation.

(1) Intended to be powered from an industrial power network that is supplied by a dedicated power transformer or generator and not from LV power lines that supply other customers.

(2) See the PowerFlex 755TS Products with TotalFORCE Control Installation Instructions, publication [750-IN119](#) for shield termination requirements.

# Single-Phase Drive Ratings

## 208V AC Input Single-Phase Ratings at 25 °C (77 °F) Surrounding Air Temperature

Drive		Without AC Line Reactor			With AC Line Reactor			AC Line Reactor
Frame	Cat. No.	Output Power [kW]	Output Current [A]	Input Current [A]	Output Power [kW]	Output Current [A]	Input Current [A]	Cat. No.
1, 2	20G...B2P2	0.18	1.3	2.4	0.18	1.3	2.1	1321-3R4-D
1, 2	20G...B4P2	0.37	2.4	4.4	0.37	2.4	3.9	1321-3R4-D
1, 2	20G...B6P8	0.75	3.9	7.1	0.75	3.9	6.4	1321-3R8-D
1, 2	20G...B9P6	1.1	5.5	10.1	1.1	5.5	9.0	1321-3R12-C
1, 2	20G...B015	2	8.7	16	2	8.7	14.1	1321-3R18-C
2	20G...B022	2.75	11.5	21	2.75	11.5	18.8	1321-3R25-C
3	20G...B028	3.75	15.4	28	3.75	15.4	25.3	1321-3R35-C
3	20G...B042	5.5	22	40	5.5	22	36.0	1321-3R45-C
4	20G...B054	7.5	30	54	7.5	30	50.0	1321-3R55-C
3	20G...B055							
5	20G...B070	7.5	30	54	15	30	50.0	1321-3R55-C
4	20G...B071							
5	20G...B080	11	43	80	11	43	72.0	1321-3R80-C
6	20G...B104	15	60	111	15	60	101.5	1321-3R100-C
6	20G...B130	18.5	72	133	18.5	72	121.8	1321-3R130-C
6	20G...B154	22.5	85	157	37	85	143.8	1321-3R160-C
6	20G...B192	33	104	192	33	104	176.6	1321-3R200-C
6	20G...B260	33	104	192	33	104	176.6	1321-3R200-C
7	20G...B312	45	170	317	45	170	317	1321-3R320-C
7	20G...B360	55	205	383	55	205	349.7	1321-3R400-C
7	20G...B477	55	205	383	66	260	443.5	1321-3R500-C

## 240V AC Input Single-Phase Ratings at 25 °C (77 °F) Surrounding Air Temperature

Drive		Without AC Line Reactor			With AC Line Reactor			AC Line Reactor
Frame	Cat. No.	Output Power [Hp]	Output Current [A]	Input Current [A]	Output Power [Hp]	Output Current [A]	Input Current [A]	Cat. No.
1, 2	20G...B2P2	0.25	1.1	2.1	0.25	1.1	1.8	1321-3R2-B
1, 2	20G...B4P2	0.5	2.1	3.9	0.5	2.1	3.4	1321-3R4-D
1, 2	20G...B6P8	1	3.4	6.4	1	3.4	5.5	1321-3R8-D
1, 2	20G...B9P6	1.5	4.8	9.0	1.5	4.8	7.8	1321-3R12-C
1, 2	20G...B015	2.5	8	15	5	8	13	1321-3R18-C
2	20G...B022	3.75	11	20	7.5	11	18	1321-3R25-C
3	20G...B028	5	14	25	10	14	23	1321-3R25-C
3	20G...B042	7.5	22	40	7.5	22	36	1321-3R45-C
4	20G...B054	10	27.5	49	10	27	45	1321-3R55-C
3	20G...B055							
5	20G...B070	15	40	75	15	40	67	1321-3R80-C
4	20G...B071							
5	20G...B080	20	52	97	20	52	88	1321-3R100-C
6	20G...B104	20	52	97	20	52	88	1321-3R100-C
6	20G...B130	25	65	121	25	65	110	1321-3R130-C
6	20G...B154	30	78	146	30	78	132	1321-3R160-C
6	20G...B192	37.5	96	179	37.5	96	163	1321-3R200-C
6	20G...B260	37.5	96	179	37.5	96	163	1321-3R200-C
7	20G...B312	62.5	156	291	62.5	156	264	1321-3R320-C
7	20G...B360	75	186	347	75	186	315	1321-3R320-C
7	20G...B477	75	186	347	100	248	423	1321-3R500-C

### 400V AC Input Single-Phase Ratings at 25 °C (77 °F) Surrounding Air Temperature

Drive		Without AC Line Reactor			With AC Line Reactor			AC Line Reactor
Frame	Cat. No.	Output Power [kW]	Output Current [A]	Input Current [A]	Output Power [kW]	Output Current [A]	Input Current [A]	Cat. No.
1	20G...C2P1	0.18	0.6	1.1	0.18	0.6	1	1321-3R2-B
1, 2	20G...C2P1	0.37	1	1.8	0.37	1	1.6	1321-3R2-B
1, 2	20G...C3P5	0.75	1.7	3.1	0.75	1.7	2.8	1321-3R4-D
1, 2	20G...C5P0	1.1	2.5	4.6	1.1	2.5	4.1	1321-3R8-D
1, 2	20G...C8P7	2	4.3	7.9	2	4.3	7	1321-3R12-C
1, 2	20G...C011	2.75	5.7	10.5	2.75	5.7	9.3	1321-3R12-C
1, 2	20G...C015	4	8.7	16	4	8.7	14.1	1321-3R18-C
2	20G...C021	5.5	11.5	21	5.5	11.5	18.8	1321-3R25-C
3	20G...C030	7.5	15.4	28	7.5	15.4	25.3	1321-3R25-C
3	20G...C037	9.25	18.5	33	9.25	18.5	30.5	1321-3R35-C
3	20G...C043	11	22	40	11	22	36	1321-3R45-C
3	20G...C061	15	30	54	15	30	50	1321-3R55-C
4	20G...C060							
4	20G...C072	18.5	37	67	18.5	37	62	1321-3R80-C
4	20G...C086	22	43	80	22	43	72	1321-3R80-C
5	20G...C085							
5	20G...C104	30	60	111	30	60	101.5	1321-3R100-C
6	20G...C140	37	72	133	37	72	121.8	1321-3R130-C
6	20G...C170	45	85	157	45	85	143.8	1321-3R160-C
6	20G...C205	55	104	192	55	104	176.6	1321-3R200-C
6	20G...C260	55	104	192	55	104	176.6	1321-3R200-C
7	20G...C302	75	140	261	75	140	236.9	1321-3R320-C
7	20G...C367	90	170	317	90	170	287.9	1321-3R320-C
7	20G...C456	110	205	383	110	205	349.7	1321-3R400-C
7	20G...C477	110	205	383	132	260	443.5	1321-3R500-C

### 480V AC Input Single-Phase Ratings at 25 °C (77 °F) Surrounding Air Temperature

Drive		Without AC Line Reactor			With AC Line Reactor			AC Line Reactor
Frame	Cat. No.	Output Power [Hp]	Output Current [A]	Input Current [A]	Output Power [Hp]	Output Current [A]	Input Current [A]	Cat. No.
1	20G...D2P1	0.25	0.5	1	0.25	0.5	0.8	1321-3R2-B
1, 2	20G...D2P1	0.5	1.1	2.1	0.5	1.1	1.8	1321-3R4-D
1, 2	20G...D3P4	1	1.7	3.2	1	1.7	2.8	1321-3R4-D
1, 2	20G...D5P0	1.5	2.5	4.7	1.5	2.5	4.1	1321-3R8-D
1, 2	20G...D8P0	2.5	4	7.5	2.5	4	6.5	1321-3R12-C
1, 2	20G...D011	3.75	5.5	10.3	3.75	5.5	8.9	1321-3R12-C
1, 2	20G...D014	5	8	15	5	8	13	1321-3R18-C
2	20G...D022	7.5	11	20	7.5	11	18	1321-3R25-C
3	20G...D027	10	14	25	10	14	23	1321-3R25-C
3	20G...D034	12.5	17	31	12.5	17	28	1321-3R35-C
3	20G...D040	15	22	40	15	22	36	1321-3R45-C
3	20G...D053	20	27	49	20	27	45	1321-3R55-C
4	20G...D052							
4	20G...D065	25	34	62	25	34	57	1321-3R80-C
4	20G...D078	30	40	75	30	40	67	1321-3R80-C
5	20G...D077							
5	20G...D096	40	52	97	40	52	88	1321-3R100-C
6	20G...D125	50	65	121	50	65	110	1321-3R130-C
6	20G...D156	60	78	146	60	78	132	1321-3R160-C
6	20G...D186	75	96	179	75	96	163	1321-3R200-C
6	20G...D248	75	96	179	75	96	163	1321-3R200-C
7	20G...D302	125	156	291	125	156	264	1321-3R320-C
7	20G...D361	150	186	347	150	186	315	1321-3R320-C
7	20G...D415	150	186	347	200	248	423	1321-3R500-C
7	20G...D477	150	186	347	200	248	423	1321-3R500-C

### 600V AC Input Single-Phase Ratings at 25 °C (77 °F) Surrounding Air Temperature

Drive		Without AC Line Reactor			With AC Line Reactor			AC Line Reactor
Frame	Cat. No.	Output Power [kW]	Output Current [A]	Input Current [A]	Output Power [kW]	Output Current [A]	Input Current [A]	Cat. No.
3	20G...E1P7	0.5	0.9	1.7	0.5	0.9	1.5	1321-3R2-B
3	20G...E2P7	1	1.4	2.7	1	1.4	2.4	1321-3R4-C
3	20G...E3P9	1.5	2	3.8	1.5	2	3.4	1321-3R4-C
3	20G...E6P1	2.5	3.1	5.9	2.5	3.1	5.3	1321-3R8-C
3	20G...E9P0	3.75	4.5	8.6	3.75	4.5	7.7	1321-3R12-C
3	20G...E011	5	5.5	10.5	5	5.5	9.5	1321-3R12-C
6	20G...E012	5	5.5	10.5	5	5.5	9.5	1321-3R12-C
3	20G...E017	7.5	9	17.1	7.5	9	15.5	1321-3R18-C
6	20G...E018	7.5	9	17.1	7.5	9	15.5	1321-3R18-C
3	20G...E022	10	12	21	10	12	19	1321-3R25-C
6	20G...E023	10	12	21	10	12	19	1321-3R25-C
6	20G...E024	10	12	21	10	12	19	1321-3R25-C
4	20G...E027	12.5	14	26.3	12.5	14	23.7	1321-3R25-C
6	20G...E028	12.5	14	26.3	12.5	14	23.7	1321-3R25-C
4	20G...E032	15	16.5	30	15	16.5	27	1321-3R35-C
6	20G...E033	15	16.5	30	15	16.5	27	1321-3R35-C
5	20G...E041	20	21	39.5	20	21	35.5	1321-3R45-C
6	20G...E042	20	21	39.5	20	21	35.5	1321-3R45-C
5	20G...E052	25	26	49	25	26	44	1321-3R55-C
6	20G...E053	25	26	49	25	26	44	1321-3R55-C
6	20G...E063	30	31.5	59.2	30	31.5	53.9	1321-3R80-C
6	20G...E077	37.5	38.5	72.4	37.5	38.5	65.8	1321-3R80-C
6	20G...E099	50	49.5	93.1	50	49.5	84.6	1321-3R100-C
6	20G...E125	62.5	62.5	117.5	62.5	62.5	106.9	1321-3R130-C
6	20G...E144	75	72	135	75	72	123	1321-3R130-C
7	20G...E192	100	96	179.5	100	96	164.2	1321-3R200-C
7	20G...E242	125	121	226.3	125	121	206.9	1321-3R250-C
7	20G...E289	150	145	271	150	145	248	1321-3R250-C

### 690V AC Input Single-Phase Ratings at 25 °C (77 °F) Surrounding Air Temperature

Drive		Without AC Line Reactor			With AC Line Reactor			AC Line Reactor
Frame	Cat. No.	Output Power [kW]	Output Current [A]	Input Current [A]	Output Power [kW]	Output Current [A]	Input Current [A]	Cat. No.
6	20G...F012	3.75	6	11	3.75	6	10.3	1321-3R12-C
6	20G...F015	5.5	7.5	14.1	5.5	7.5	12.9	1321-3R18-C
6	20G...F020	7.5	10	18.8	7.5	10	17.2	1321-3R25-C
6	20G...F023	9.25	11.5	21.6	9.25	11.5	19.8	1321-3R25-C
6	20G...F030	11	15	28.2	11	15	25.8	1321-3R35-C
6	20G...F034	15	17	32	15	17	29.2	1321-3R45-C
6	20G...F046	18.5	23	43.2	18.5	23	39.6	1321-3R55-C
6	20G...F050	22	25	47	22	25	43	1321-3R55-C
6	20G...F061	27.5	30.5	57	27.5	30.5	52.2	1321-3R80-C
6	20G...F082	37.5	41	76.7	37.5	41	70.1	1321-3R80-C
6	20G...F098	45	49	91.6	45	49	83.8	1321-3R100-C
6	20G...F119	55	59.5	113	55	59.5	101.7	1321-3R130-C
6	20G...F142	66	71	133	66	71	121	1321-3R130-C
7	20G...F171	80	85	159	80	85	145	1321-3R160-C
7	20G...F212	100	106	199	100	106	181.3	1321-3R200-C
7	20G...F263	125	132	247	125	132	226	1321-3R250-C

# Design Considerations

This section provides information for design considerations.

## Input Voltage Tolerance

Drive Rating	Nominal Line Voltage	Nominal Motor Voltage	Drive Full Power Range	Drive Operating Range
200...240	200	200	200...264	180...264
	208	208	208...264	
	240	230	230...264	
380...480	380	361	380...528	342...528
	400	380	400...528	
	480	460	460...528	
600...690	600	575	575...759	517...759
	690	660	660...759	

Drive Full Power Range = Nominal Motor Voltage to Nominal Line Voltage + 10%.  
 Rated current is available across the entire Drive Full Power Range

Drive Operating Range = Nominal Line Voltage - 10% to Drive Rated Voltage + 10%. Drive Output is linearly derated when Actual Line Voltage is less than the Nominal Motor Voltage

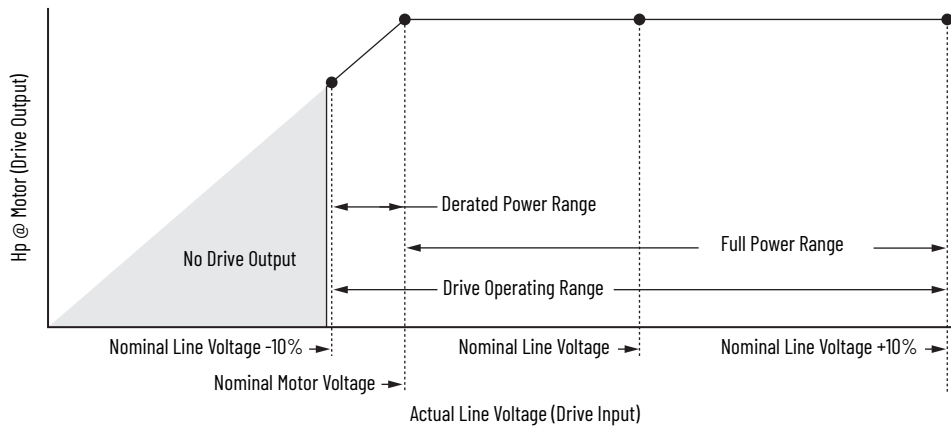

**EXAMPLE** Calculate the maximum power of a 5.0 Hp, 460V motor connected to a 480V-rated drive supplied with 342V Actual Line Voltage input.

- Actual Line Voltage / Nominal Motor Voltage = 74.3%
- 74.3% x 5.0 Hp = 3.7 Hp
- 74.3% x 60 Hz = 44.6 Hz

At 342V Actual Line Voltage, the maximum power the 5.0 Hp, 460V motor can produce is 3.7 Hp at 44.6 Hz.

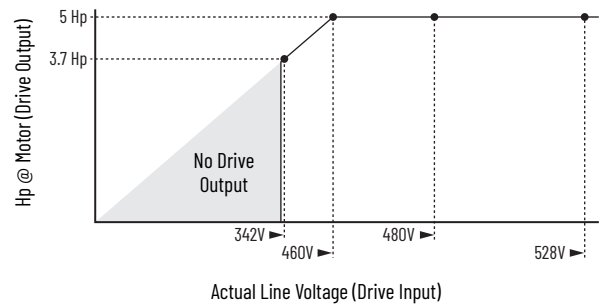

## Approximate Watts Loss

The following table lists watts loss data for PowerFlex 755TS drives running at full load, full speed, and default carrier frequency.

Internal watts are the watts that the control structure of the drive dissipates into the cabinet, regardless of mounting style. External watts are the watts that are dissipated directly through the heatsink and are outside the cabinet for flange mount, and inside the cabinet for other mounting types.

### Watts Loss for 208/240V Drives

Cat. No.	Normal Duty		Frame	External Watts	Internal Watts	Total Watts	Cat. No.	Normal Duty		Frame	External Watts	Internal Watts	Total Watts
	kW	Continuous Output Amps						Hp	Continuous Output Amps				
<b>208 Volt</b>							<b>240 Volt</b>						
20G...B2P2	0.37	2.5	2 (1)	34 (23)	57 (57)	91 (80)	20G...B2P2	0.5	2.2	2 (1)	29 (20)	61 (56)	90 (76)
20G...B4P2	0.75	4.8	2 (1)	63 (46)	60 (62)	123 (108)	20G...B4P2	1	4.2	2 (1)	52 (40)	63 (60)	115 (100)
20G...B6P8	1.5	7.8	2 (1)	80 (72)	64 (75)	144 (147)	20G...B6P8	2	6.8	2 (1)	67 (61)	66 (71)	133 (132)
20G...B9P6	2.2	11	2 (1)	110 (99)	70 (82)	180 (181)	20G...B9P6	3	9.6	2 (1)	92 (84)	71 (76)	163 (160)
20G...B015	4	17.5 (15.3)	2 (1)	169 (157)	76 (79)	245 (236)	20G...B015	5	15	2 (1)	141 (158)	76 (80)	217 (238)
20G...B022	5.5	22	2	237	87	324	20G...B022	7.5	22	2	240	92	331
20G...B028	7.5	32.2	3	328	104	432	20G...B028	10	28	3	272	98	370
20G...B042	11	43	3	459	122	581	20G...B042	15	42	3	458	125	583
20G...B054	15	60	4	505	132	637	20G...B054	20	54	4	439	128	567
20G...B055	15	61	3	505	132	637	20G...B055	20	55	3	439	128	567
20G...B070	18.5	78.2	5	643	152	796	20G...B070	25	70	5	557	146	703
20G...B071	18.5	79	4	643	152	796	20G...B071	25	71	4	557	146	703
20G...B080	22	92	5	788	181	969	20G...B080	30	80	5	653	163	816
20G...B104	30	120	6	1054	274	1327	20G...B104	40	104	6	874	252	1126
20G...B130	37	150	6	1184	266	1449	20G...B130	50	130	6	997	248	1245
20G...B154	45	177	6	1492	317	1808	20G...B154	60	154	6	1250	288	1538
20G...B192	55	221	6	1921	403	2324	20G...B192	75	192	6	1597	355	1952
20G...B260	66	260	6	2418	499	2917	20G...B260	100	260	6	2426	513	2939
20G...B312	90	359	7	3120	561	3681	20G...B312	125	312	7	2602	491	3094
20G...B360	110	414	7	3384	646	4029	20G...B360	150	360	7	2817	557	3373
20G...B477	132	477	7	4135	789	4924	20G...B477	200	477	7	4156	810	4966

## Watts Loss for 400/480V Drives

Cat. No.	Normal Duty		Frame	External Watts	Internal Watts	Total Watts	Cat. No.	Normal Duty		Frame	External Watts	Internal Watts	Total Watts
	kW	Continuous Output Amps						Hp	Continuous Output Amps				
<b>400 Volt</b>							<b>480 Volt</b>						
20G...C2P1	0.75	2.1	2 (1)	16 (16)	55 (56)	71 (72)	20G...D2P1	1.0	2.1	2 (1)	17 (21)	60 (61)	77 (82)
20G...C3P5	1.5	3.5	2 (1)	26 (33)	57 (60)	83 (93)	20G...D3P4	2.0	3.4	2 (1)	27 (39)	61 (64)	88 (103)
20G...C5P0	2.2	5	2 (1)	39 (44)	58 (62)	97 (106)	20G...D5P0	3.0	5	2 (1)	41 (54)	63 (67)	104 (121)
20G...C8P7	4.0	8.7	2 (1)	75 (79)	64 (80)	139 (159)	20G...D8P0	5.0	8	2 (1)	71 (91)	68 (82)	139 (173)
20G...C011	5.5	11.5	2 (1)	108 (107)	70 (80)	178 (187)	20G...D011	7.5	11	2 (1)	108 (118)	74 (88)	182 (206)
20G...C015	7.5	15.4	2 (1)	161 (166)	80 (80)	241 (246)	20G...D014	10	14	2 (1)	149 (152)	81 (81)	230 (233)
20G...C022	11	22	2	225	86	311	20G...D022	15	22	2	237	91	328
20G...C030	15	30	3	300	103	403	20G...D027	20	27	3	273	101	374
20G...C037	18.5	37	3	362	115	477	20G...D034	25	34	3	368	115	483
20G...C043	22	43	3	505	126	631	20G...D040	30	40	3	503	126	629
20G...C060	30	60	4	540	152	692	20G...D052	40	52	4	455	135	590
20G...C061	30	61	3	619	158	777	20G...D053	40	53	3	537	142	679
20G...C072	37	72	5 (4)	549 (615)	162 (151)	711 (766)	20G...D065	50	65	5 (4)	502 (559)	155 (148)	657 (707)
20G...C073	37	73	4	487	134	621	20G...D066	50	66	4	422	129	551
20G...C085	45	85	5	705	166	871	20G...D077	60	77	5	646	162	808
20G...C086	45	86	4	661	177	838	20G...D078	60	78	4	596	162	758
20G...C104	55	104	6 (5)	825 (928)	261 (205)	1086 (1133)	20G...D096	75	96	6 (5)	781 (855)	248 (193)	1029 (1048)
20G...C140	75	140	6	1239	329	1568	20G...D125	100	125	6	1109	309	1418
20G...C170	90	170	6	1381	310	1691	20G...D156	125	156	6	1299	304	1603
20G...C205	110	205	6	1893	391	2284	20G...D186	150	186	6	1718	368	2086
20G...C260	132	260	7 (6)	2061 (2449)	437 (512)	2498 (2961)	20G...D248	200	248	7 (6)	2058 (2384)	464 (501)	2522 (2885)
20G...C302	160	302	7	2566	471	3037	20G...D302	250	302	7	2704	501	3205
20G...C367	200	367	7	3322	596	3918	20G...D361	300	361	7	3409	616	4025
20G...C456	250	456	7	3472	765	4237	20G...D415	350	415	7	3232	693	3925
20G...C477	270	477	7	3647	808	4455	20G...D477	400	477	7	3823	822	4645

## Watts Loss for 600/690V Drives

Cat. No.	Normal Duty		Frame	External Watts	Internal Watts	Total Watts	Cat. No.	Normal Duty		Frame	External Watts	Internal Watts	Total Watts
	Hp	Continuous Output Amps						kW	Continuous Output Amps				
<b>600 Volt</b>							<b>690 Volt</b>						
20G...E1P7	1	1.7	3	23	15	38							
20G...E2P7	2	2.7	3	40	17	57							
20G...E3P9	3	3.9	3	51	18	69							
20G...E6P1	5	6.1	3	80	22	102							
20G...E9P0	7.5	9	3	122	29	151							
20G...E011	10	11	3	152	34	186							
20G...E012	10	12	6	168	50	218	20G...F012	7.5	12	6	169	50	219
20G...E017	15	17	3	249	54	303							
20G...E018	15	18	6	269	61	330	20G...F015	11	15	6	226	56	282
20G...E022	20	22	3	329	74	403							
20G...E023	20	23	6	332	70	402	20G...F020	15	20	6	296	65	361
20G...E024	20	24	6	326	71	397	20G...F023	18.5	23	6	327	70	397
20G...E027	25	27	4	411	84	495							
20G...E028	25	28	6	375	79	454	20G...F030	22	30	6	428	85	513
20G...E032	30	32	4	503	105	608							
20G...E033	30	33	6	439	90	529	20G...F034	30	34	6	478	94	572
20G...E041	40	41	5	590	128	718							
20G...E042	40	42	6	555	112	667	20G...F046	37	46	6	649	126	775
20G...E052	50	52	5	784	176	959							
20G...E053	50	53	6	711	144	855	20G...F050	45	50	6	699	138	837
20G...E063	60	63	6	757	132	889	20G...F061	55	61	6	760	130	890
20G...E077	75	77	6	935	166	1101	20G...F082	75	82	6	1044	182	1226
20G...E099	100	99	6	1269	229	1498	20G...F098	90	98	6	1310	231	1541
20G...E125	125	125	6	1678	318	1996	20G...F119	110	119	6	1658	302	1960
20G...E144	150	144	6	1960	389	2349	20G...F142	132	142	6	2003	387	2390
20G...E192	200	192	7	2801	433	3234	20G...F171	160	171	7	2655	389	3044
20G...E242	250	242	7	3642	593	4235	20G...F212	200	212	7	3375	513	3888
20G...E289	300	289	7	4437	762	5199	20G...F263	250	263	7	4286	690	4976

# Derating Guidelines

The following sections describe conditional derating guidelines for low frequency operation, ambient temperature, and altitude operational limits.

Low Frequency Derating Section	Page
Low Frequency Derating—208V	37
Low Frequency Derating—240V	46
Low Frequency Derating—400V	55
Low Frequency Derating—480V	66
Low Frequency Derating—600V	77
Low Frequency Derating—690V	87

Ambient Temperature Derating Section	Page
Ambient Temperature Derating—208V	93
Ambient Temperature Derating—240V	102
Ambient Temperature Derating—400V	111
Ambient Temperature Derating—480V	122
Ambient Temperature Derating—600V	133
Ambient Temperature Derating—690V	143

Altitude Derating Section	Page
Altitude Derating—208V	149
Altitude Derating—240V	158
Altitude Derating—400V	167
Altitude Derating—480V	178
Altitude Derating—600V	189
Altitude Derating—690V	199

## Calculate Effective Rating

When you have to consider a combination of ambient temperature, altitude, PWM frequency, and output fundamental frequency, we use this calculation to find the effective rating.

$$\text{Effective Rating} = \text{Amps}_{\text{BASE}} \times F_{\text{AMB}} \times F_{\text{ALT}} \times F_{\text{LS}}$$

For this example the drive is: 480V, 53A (code D053), 40 Hp, frame 3, with 2 kHz default PWM. Find the derating at 8 kHz, 40 °C, 2000 m, and 6 Hz output.

- Note the drive base current rating ( $\text{Amps}_{\text{BASE}}$ ). In this example it is 53.
- Look up the ambient derating ( $F_{\text{AMB}}$ ) specified at 0 m altitude and rated (60 Hz) output fundamental frequency. This data is absolute.
  - From the ambient derating graph for code D053, the rating at 8 kHz, 40 °C, 0 m, 60 Hz = 0.9

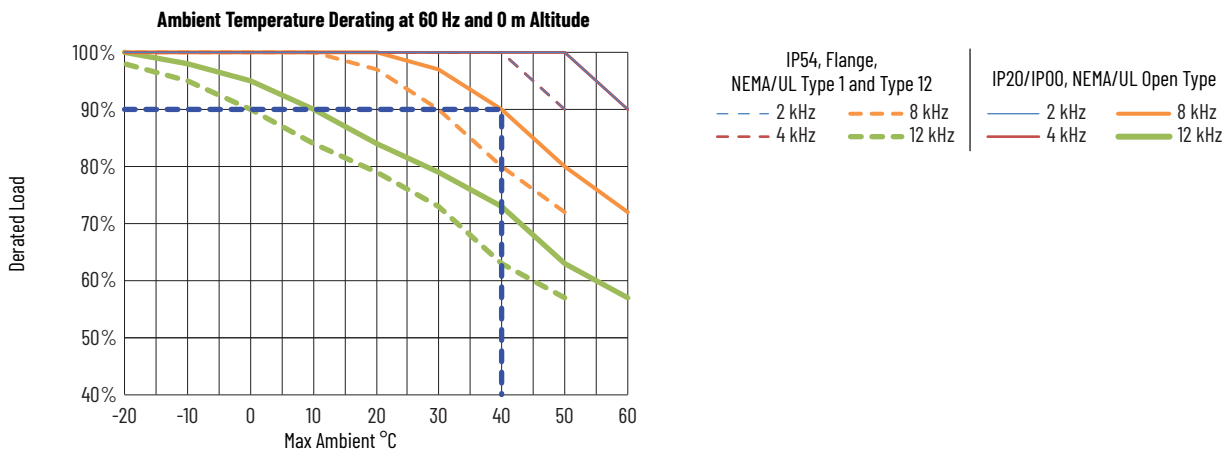

3. Look up the altitude derating ( $F_{ALT}$ ) specified at maximum rated ambient temperature and rated (60 Hz) output fundamental frequency. This data is normalized such that rating at 0 m is always 100%.

- From the altitude derating graph for code D053, the rating at 8 kHz, 40 °C, 2000 m, 60 Hz =  $0.9 \times 0.71 (2000 \text{ m}) / 0.8 (0 \text{ m}) = 0.8$

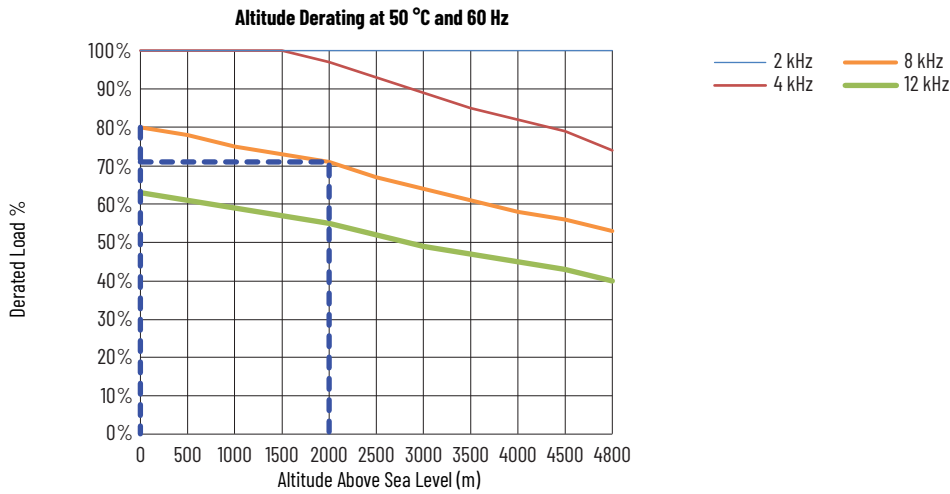

4. Look up the low frequency derating ( $F_{LS}$ ) specified at maximum rated ambient temperature and 0m altitude. Data is normalized such that the rating at 60 Hz is always 100%.

- From the low frequency derating graph for code D053, the rating at 8 kHz, 40 °C, 2000 m, 6 Hz =  $0.8 \times 0.72 (6 \text{ Hz}) / 0.8 (60 \text{ Hz}) = 0.72$

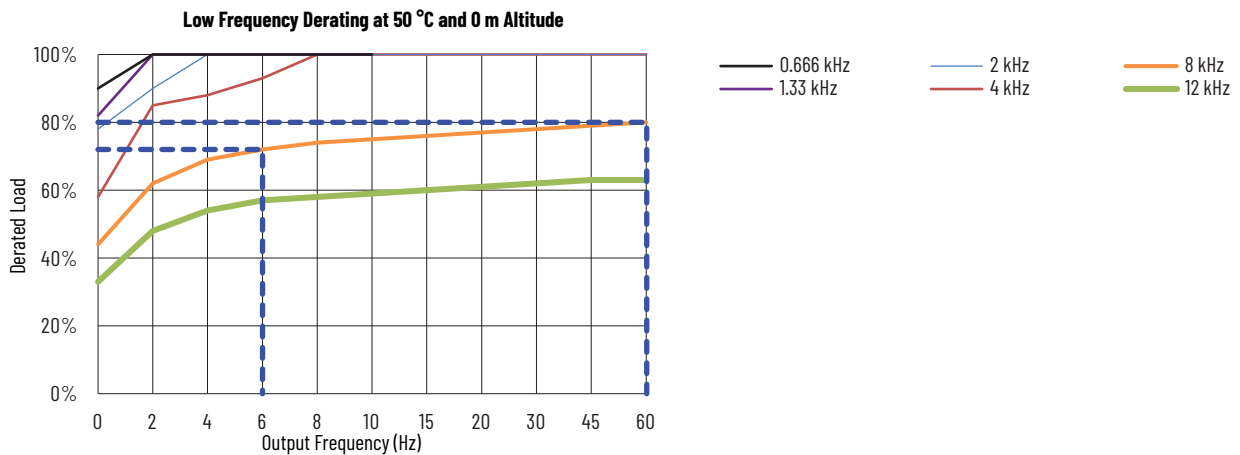

5. Plug the base current rating and derating values into the equation to find the effective rating.

- $Amps_{BASE} = 53$
- $F_{AMB} = 0.9$
- $F_{ALT} = 0.8$
- $F_{LS} = 0.72$

Effective Rating =  $53 \times 0.9 \times 0.8 \times 0.72 = 27.5$

## Low Frequency Derating—208V

The following graphs show the low frequency deratings for 208V PowerFlex 755TS drives specified at the maximum rated ambient temperature at 0 meters altitude.

### Low Frequency Derating Curves—208V AC Frames 1..7

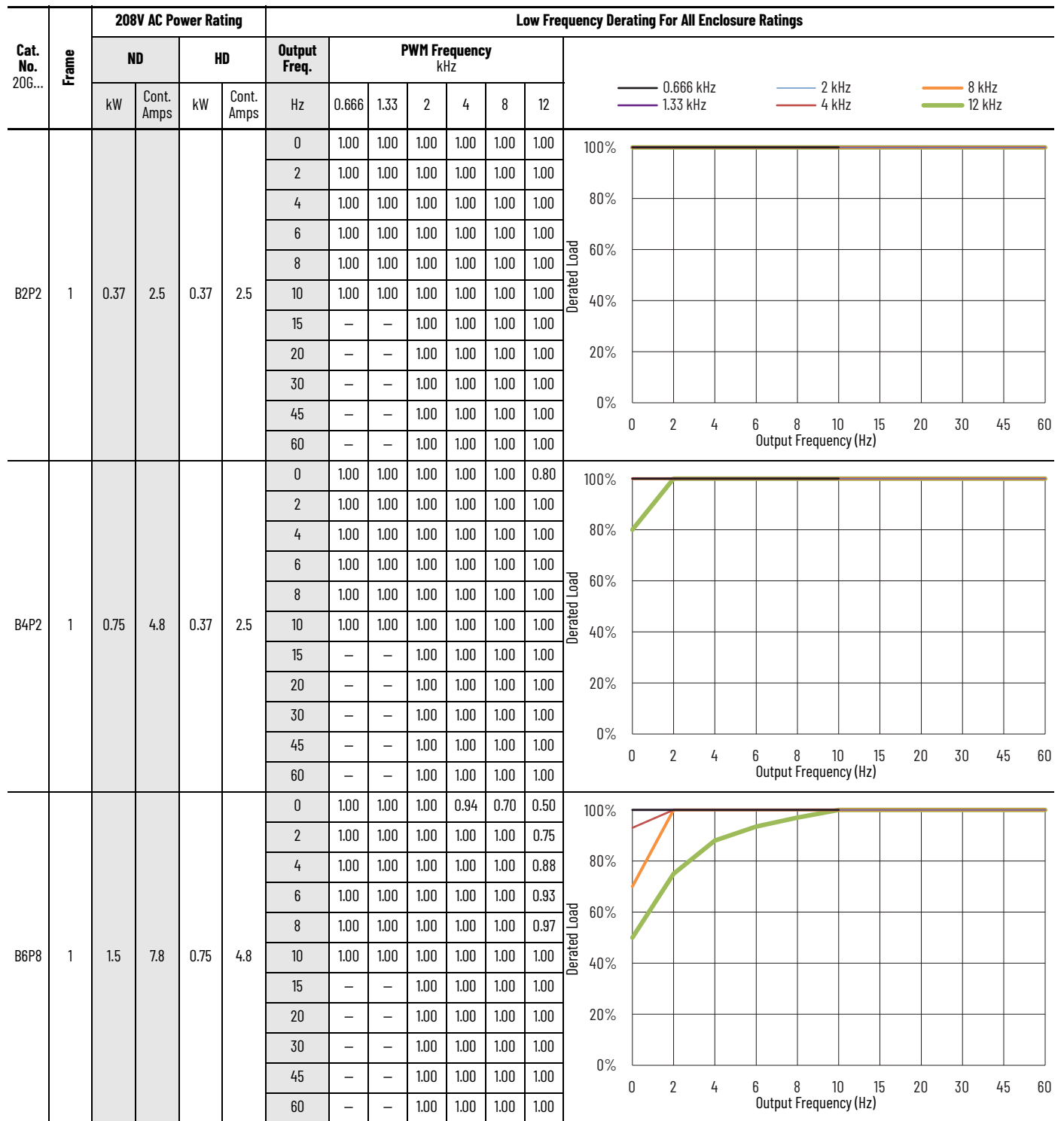

### Low Frequency Derating Curves—208V AC Frames 1...7 (Continued)

Cat. No. 20G...	Frame	208V AC Power Rating				Low Frequency Derating For All Enclosure Ratings							
		ND		HD		Output Freq. Hz	PWM Frequency kHz						
		kW	Cont. Amps	kW	Cont. Amps		0.666	1.33	2	4	8	12	
B9P6	1	2.2	11	1.5	7.8	0	1.00	1.00	1.00	1.00	1.00	0.77	
						2	1.00	1.00	1.00	1.00	1.00	0.82	
						4	1.00	1.00	1.00	1.00	1.00	0.88	
						6	1.00	1.00	1.00	1.00	1.00	0.92	
						8	1.00	1.00	1.00	1.00	1.00	0.95	
						10	1.00	1.00	1.00	1.00	1.00	0.98	
						15	—	—	1.00	1.00	1.00	1.00	
						20	—	—	1.00	1.00	1.00	1.00	
						30	—	—	1.00	1.00	1.00	1.00	
						45	—	—	1.00	1.00	1.00	1.00	
60	—	—	1.00	1.00	1.00	1.00							
B015	1	4	15.3	2.2	11	0	1.00	1.00	1.00	1.00	0.80	0.60	
						2	1.00	1.00	1.00	1.00	0.83	0.65	
						4	1.00	1.00	1.00	1.00	0.88	0.69	
						6	1.00	1.00	1.00	1.00	0.92	0.72	
						8	1.00	1.00	1.00	1.00	0.95	0.75	
						10	1.00	1.00	1.00	1.00	0.97	0.77	
						15	—	—	1.00	1.00	1.00	0.80	
						20	—	—	1.00	1.00	1.00	0.82	
						30	—	—	1.00	1.00	1.00	0.85	
						45	—	—	1.00	1.00	1.00	0.86	
60	—	—	1.00	1.00	1.00	0.87							
B2P2	2	0.37	2.5	0.37	2.5	0	1.00	1.00	1.00	1.00	1.00	1.00	
						2	1.00	1.00	1.00	1.00	1.00	1.00	
						4	1.00	1.00	1.00	1.00	1.00	1.00	
						6	1.00	1.00	1.00	1.00	1.00	1.00	
						8	1.00	1.00	1.00	1.00	1.00	1.00	
						10	1.00	1.00	1.00	1.00	1.00	1.00	
						15	—	—	1.00	1.00	1.00	1.00	
						20	—	—	1.00	1.00	1.00	1.00	
						30	—	—	1.00	1.00	1.00	1.00	
						45	—	—	1.00	1.00	1.00	1.00	
60	—	—	1.00	1.00	1.00	1.00							

### Low Frequency Derating Curves—208V AC Frames 1...7 (Continued)

Cat. No. 20G...	Frame	208V AC Power Rating				Low Frequency Derating For All Enclosure Ratings								
		ND		HD		Output Freq. Hz	PWM Frequency kHz							
		kW	Cont. Amps	kW	Cont. Amps		0.666	1.33	2	4	8	12		
B4P2	2	0.75	4.8	0.75	4.8	0	1.00	1.00	1.00	1.00	1.00	1.00		
						2	1.00	1.00	1.00	1.00	1.00	1.00		1.00
						4	1.00	1.00	1.00	1.00	1.00	1.00		1.00
						6	1.00	1.00	1.00	1.00	1.00	1.00		1.00
						8	1.00	1.00	1.00	1.00	1.00	1.00		1.00
						10	1.00	1.00	1.00	1.00	1.00	1.00		1.00
						15	–	–	1.00	1.00	1.00	1.00		1.00
						20	–	–	1.00	1.00	1.00	1.00		1.00
						30	–	–	1.00	1.00	1.00	1.00		1.00
						45	–	–	1.00	1.00	1.00	1.00		1.00
60	–	–	1.00	1.00	1.00	1.00	1.00							
B6P8	2	1.5	7.8	1.5	7.8	0	1.00	1.00	1.00	1.00	1.00	0.80		
						2	1.00	1.00	1.00	1.00	1.00	1.00		1.00
						4	1.00	1.00	1.00	1.00	1.00	1.00		1.00
						6	1.00	1.00	1.00	1.00	1.00	1.00		1.00
						8	1.00	1.00	1.00	1.00	1.00	1.00		1.00
						10	1.00	1.00	1.00	1.00	1.00	1.00		1.00
						15	–	–	1.00	1.00	1.00	1.00		1.00
						20	–	–	1.00	1.00	1.00	1.00		1.00
						30	–	–	1.00	1.00	1.00	1.00		1.00
						45	–	–	1.00	1.00	1.00	1.00		1.00
60	–	–	1.00	1.00	1.00	1.00	1.00							
B9P6	2	2.2	11	2.2	11	0	1.00	1.00	1.00	1.00	0.75	0.60		
						2	1.00	1.00	1.00	1.00	1.00	0.83		0.83
						4	1.00	1.00	1.00	1.00	1.00	0.95		0.95
						6	1.00	1.00	1.00	1.00	1.00	1.00		1.00
						8	1.00	1.00	1.00	1.00	1.00	1.00		1.00
						10	1.00	1.00	1.00	1.00	1.00	1.00		1.00
						15	–	–	1.00	1.00	1.00	1.00		1.00
						20	–	–	1.00	1.00	1.00	1.00		1.00
						30	–	–	1.00	1.00	1.00	1.00		1.00
						45	–	–	1.00	1.00	1.00	1.00		1.00
60	–	–	1.00	1.00	1.00	1.00	1.00							

### Low Frequency Derating Curves—208V AC Frames 1...7 (Continued)

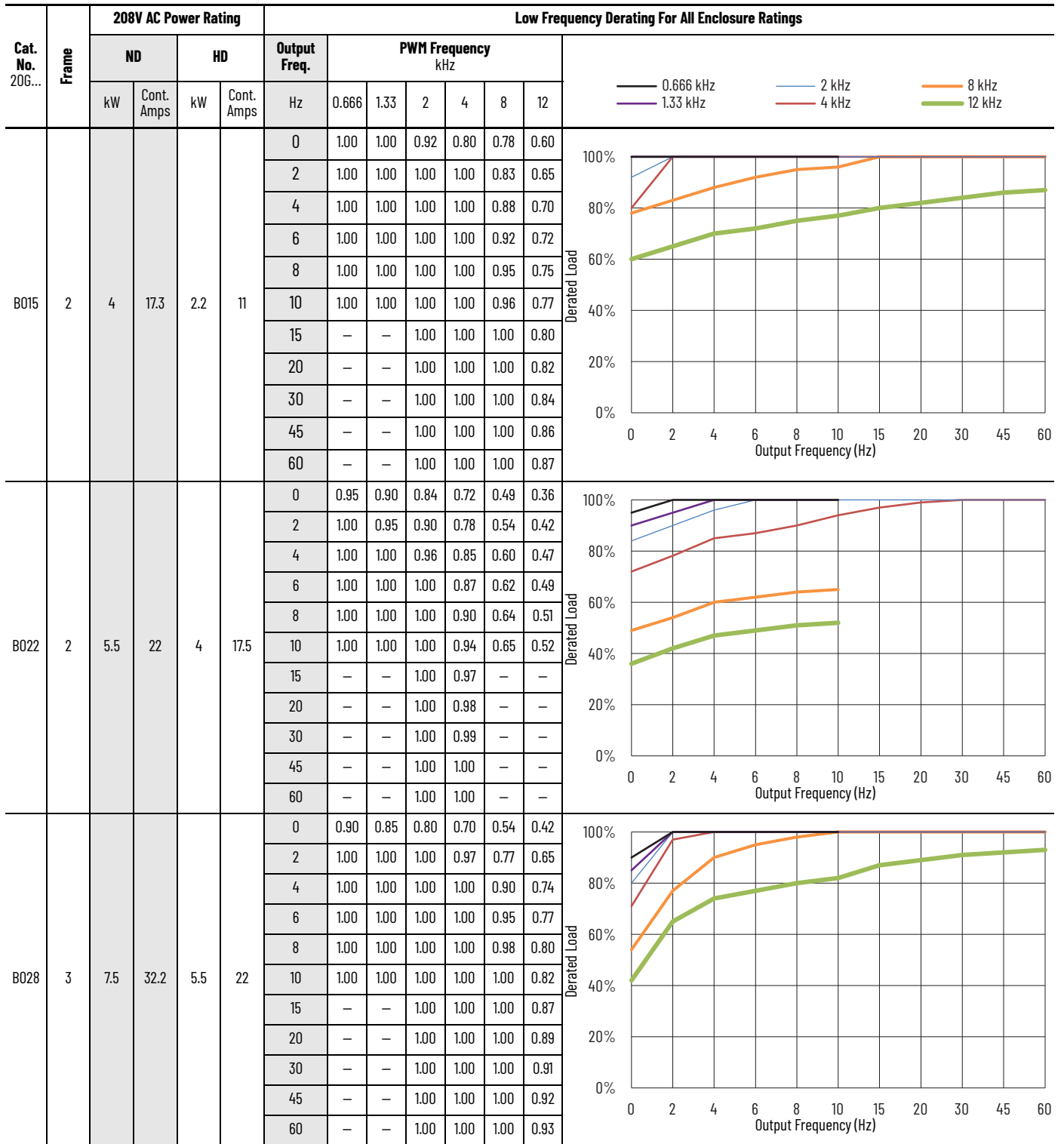

### Low Frequency Derating Curves—208V AC Frames 1...7 (Continued)

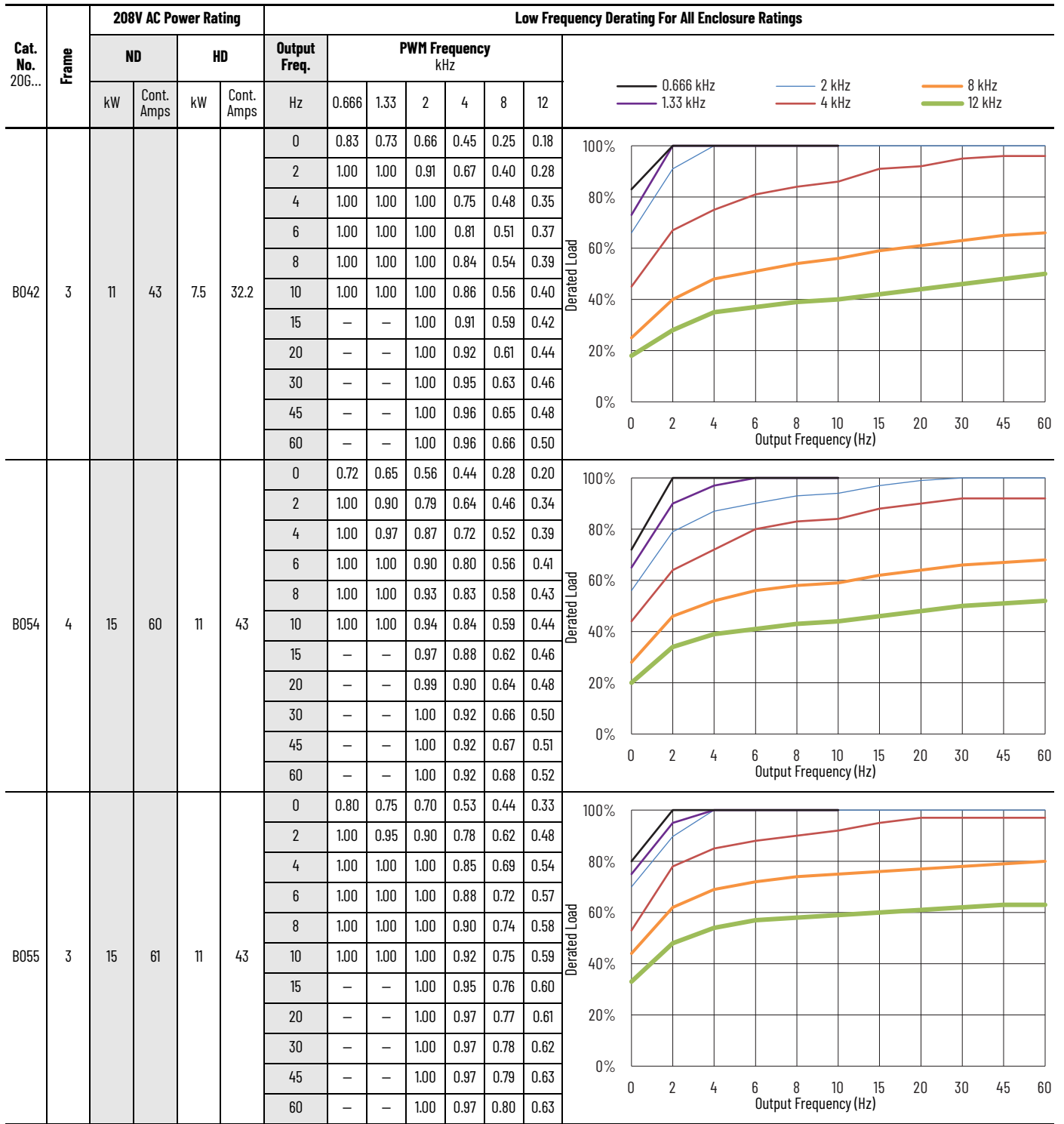

**Low Frequency Derating Curves—208V AC Frames 1...7 (Continued)**

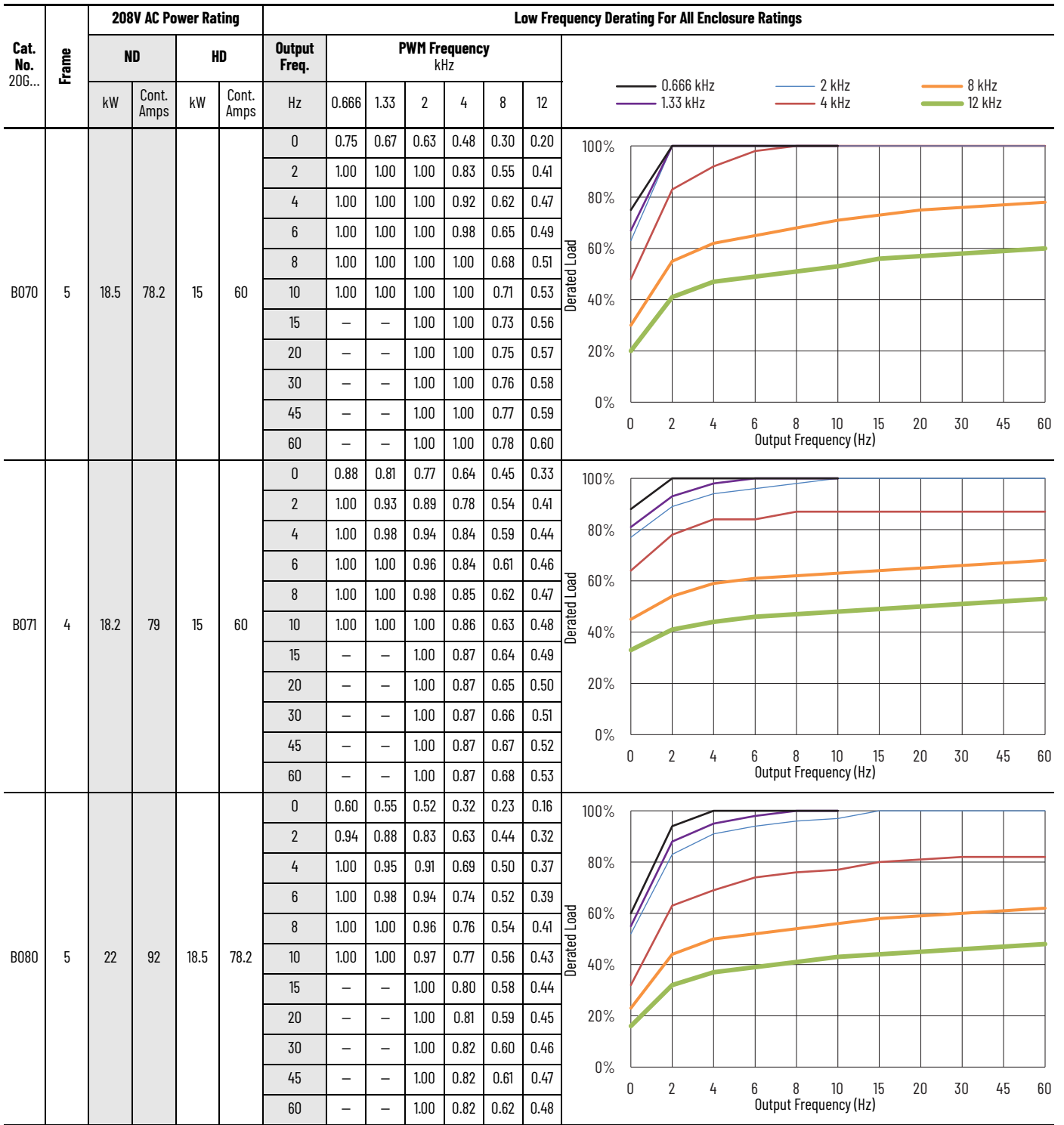

### Low Frequency Derating Curves—208V AC Frames 1...7 (Continued)

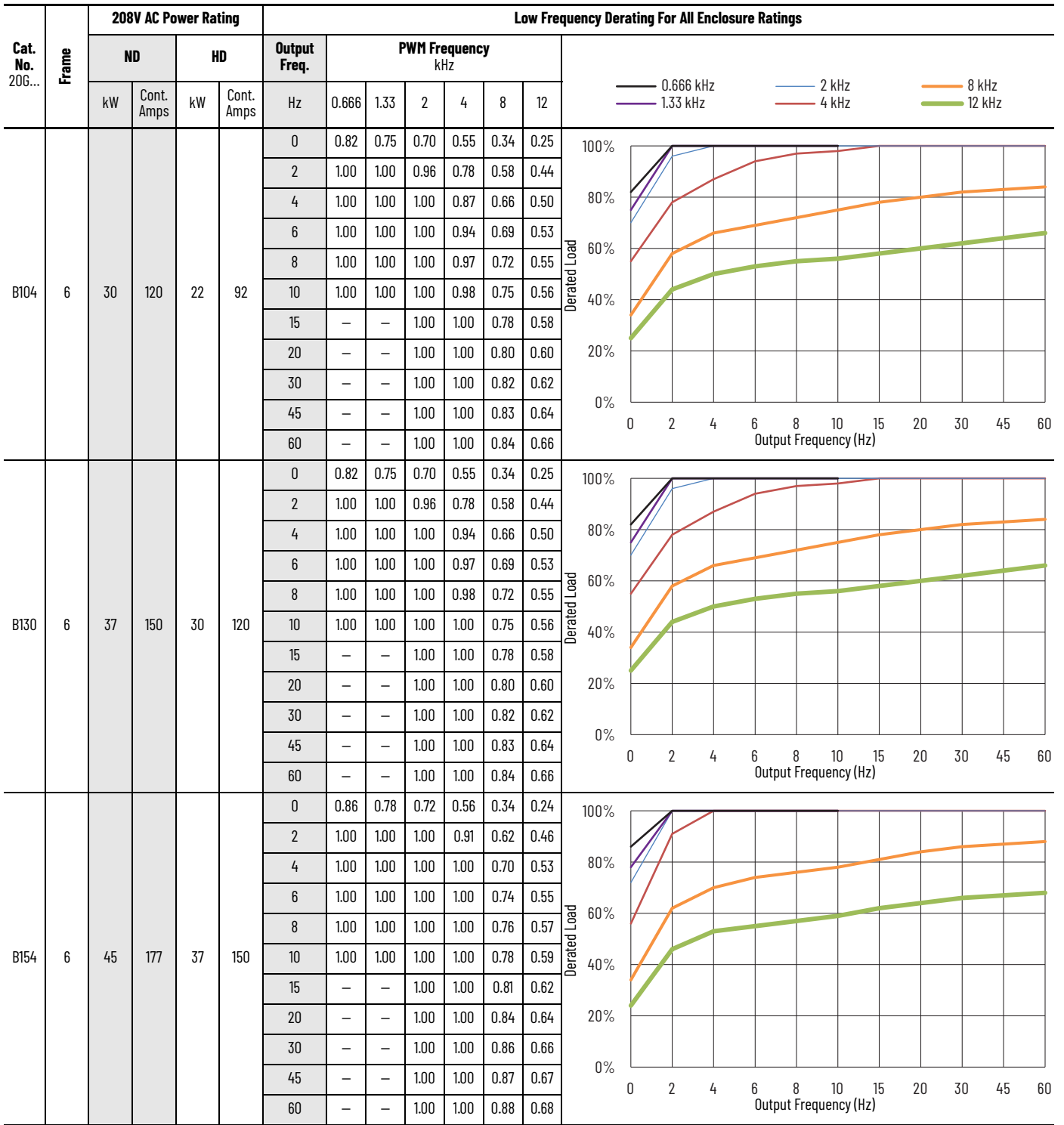

## Low Frequency Derating Curves—208V AC Frames 1...7 (Continued)

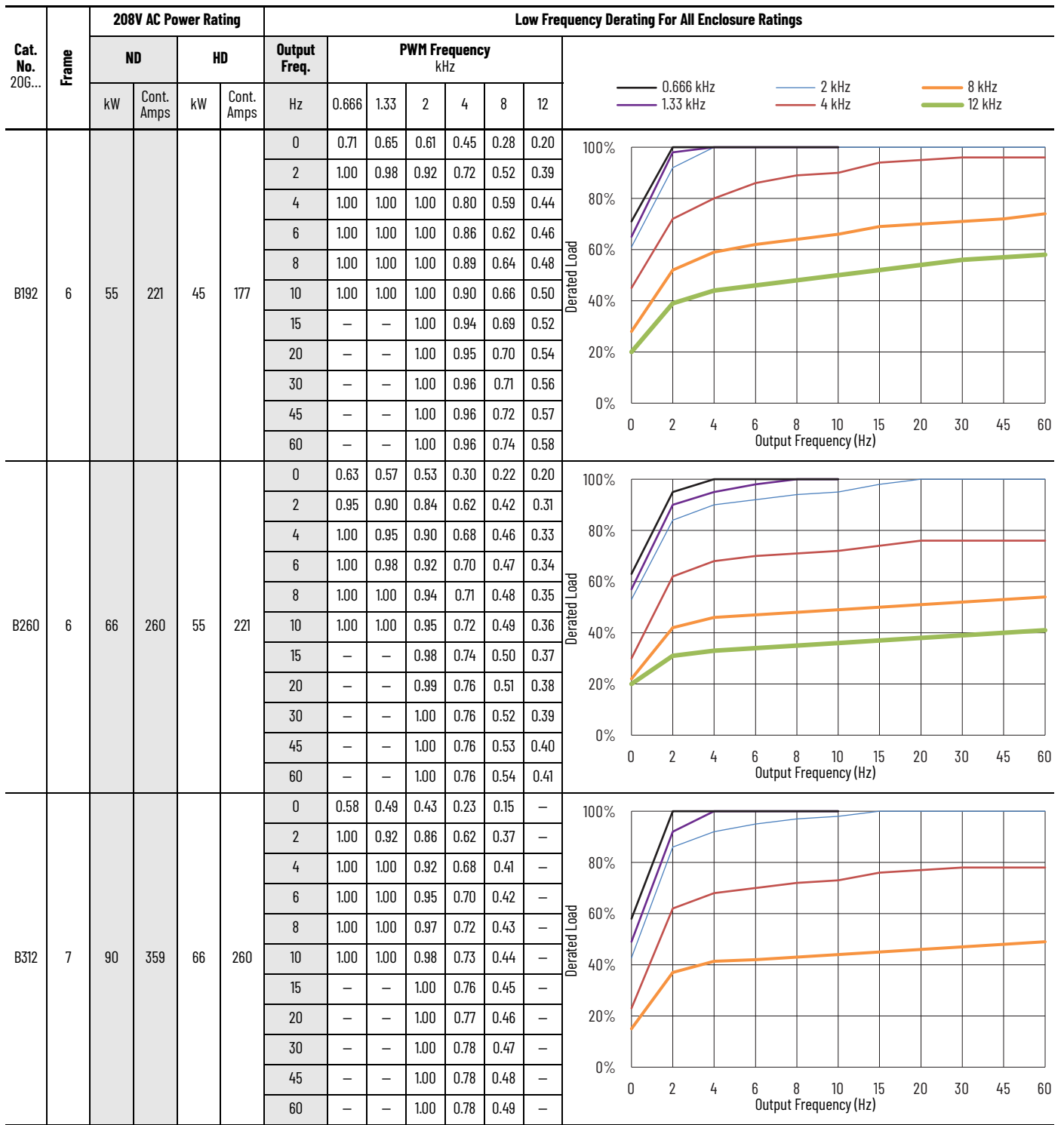

### Low Frequency Derating Curves—208V AC Frames 1...7 (Continued)

Cat. No. 206...	Frame	208V AC Power Rating				Low Frequency Derating For All Enclosure Ratings							
		ND		HD		Output Freq. Hz	PWM Frequency kHz						
		kW	Cont. Amps	kW	Cont. Amps		0.666	1.33	2	4	8	12	
B360	7	110	414	90	359	0	0.58	0.49	0.43	0.23	0.15	—	
						2	1.00	0.92	0.86	0.62	0.37	—	
						4	1.00	1.00	0.92	0.68	0.41	—	
						6	1.00	1.00	0.95	0.70	0.42	—	
						8	1.00	1.00	0.97	0.72	0.43	—	
						10	1.00	1.00	0.98	0.73	0.44	—	
						15	—	—	1.00	0.76	0.45	—	
						20	—	—	1.00	0.77	0.46	—	
						30	—	—	1.00	0.78	0.47	—	
						45	—	—	1.00	0.78	0.48	—	
60	—	—	1.00	0.78	0.49	—							
B477	7	132	477	90	359	0	0.63	0.55	0.50	0.34	0.18	—	
						2	1.00	1.00	0.90	0.70	0.39	—	
						4	1.00	1.00	0.95	0.73	0.40	—	
						6	1.00	1.00	0.96	0.74	0.41	—	
						8	1.00	1.00	0.98	0.75	0.42	—	
						10	1.00	1.00	0.99	0.76	0.43	—	
						15	—	—	1.00	0.77	0.44	—	
						20	—	—	1.00	0.78	0.45	—	
						30	—	—	1.00	0.78	0.46	—	
						45	—	—	1.00	0.78	0.47	—	
60	—	—	1.00	0.78	0.48	—							

# Low Frequency Derating—240V

The following graphs show the low frequency deratings for 240V PowerFlex 755TS drives specified at the maximum rated ambient temperature at 0 meters altitude.

## Low Frequency Derating Curves—240V AC Frames 1..7

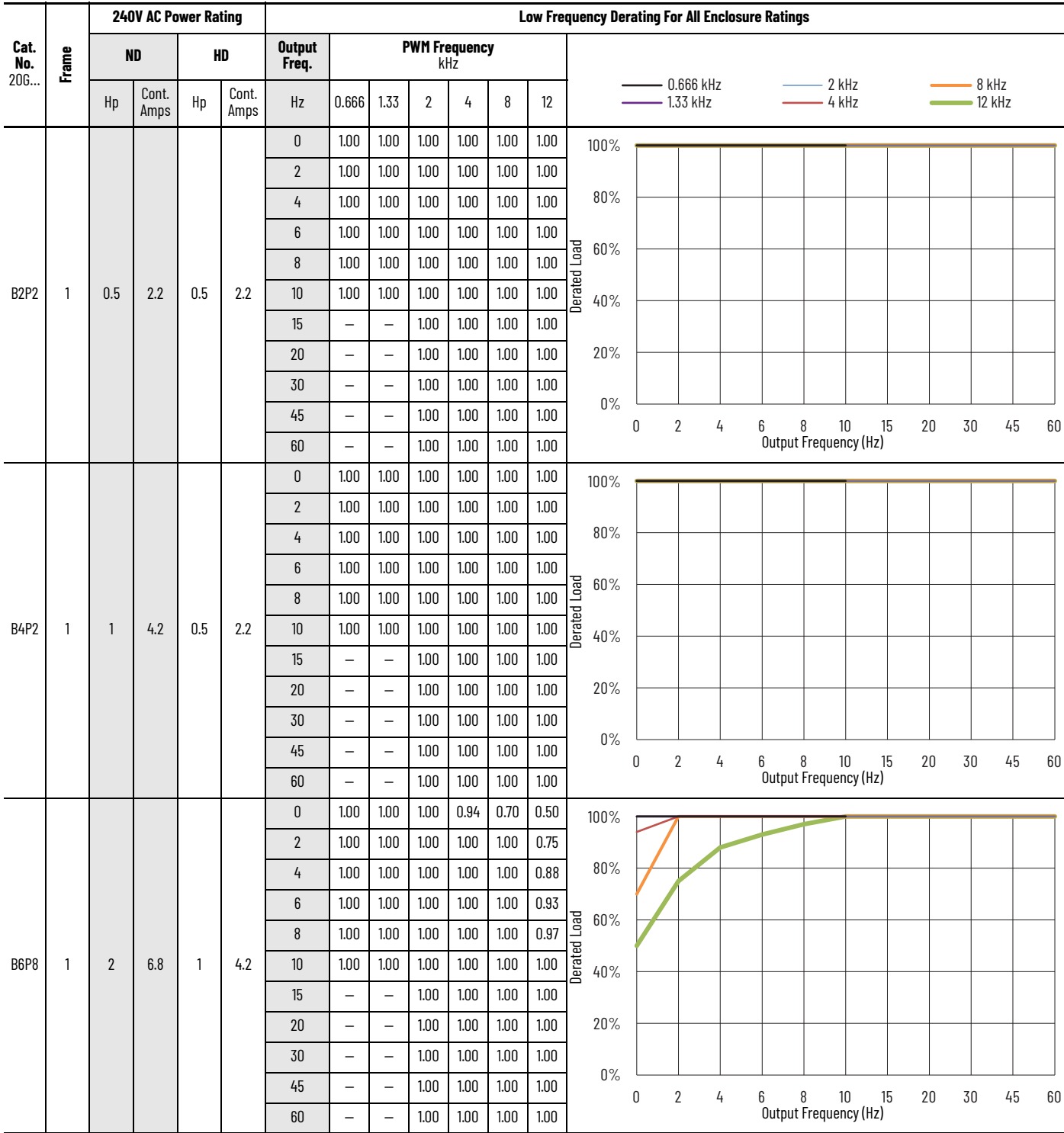

## Low Frequency Derating Curves—240V AC Frames 1..7 (Continued)

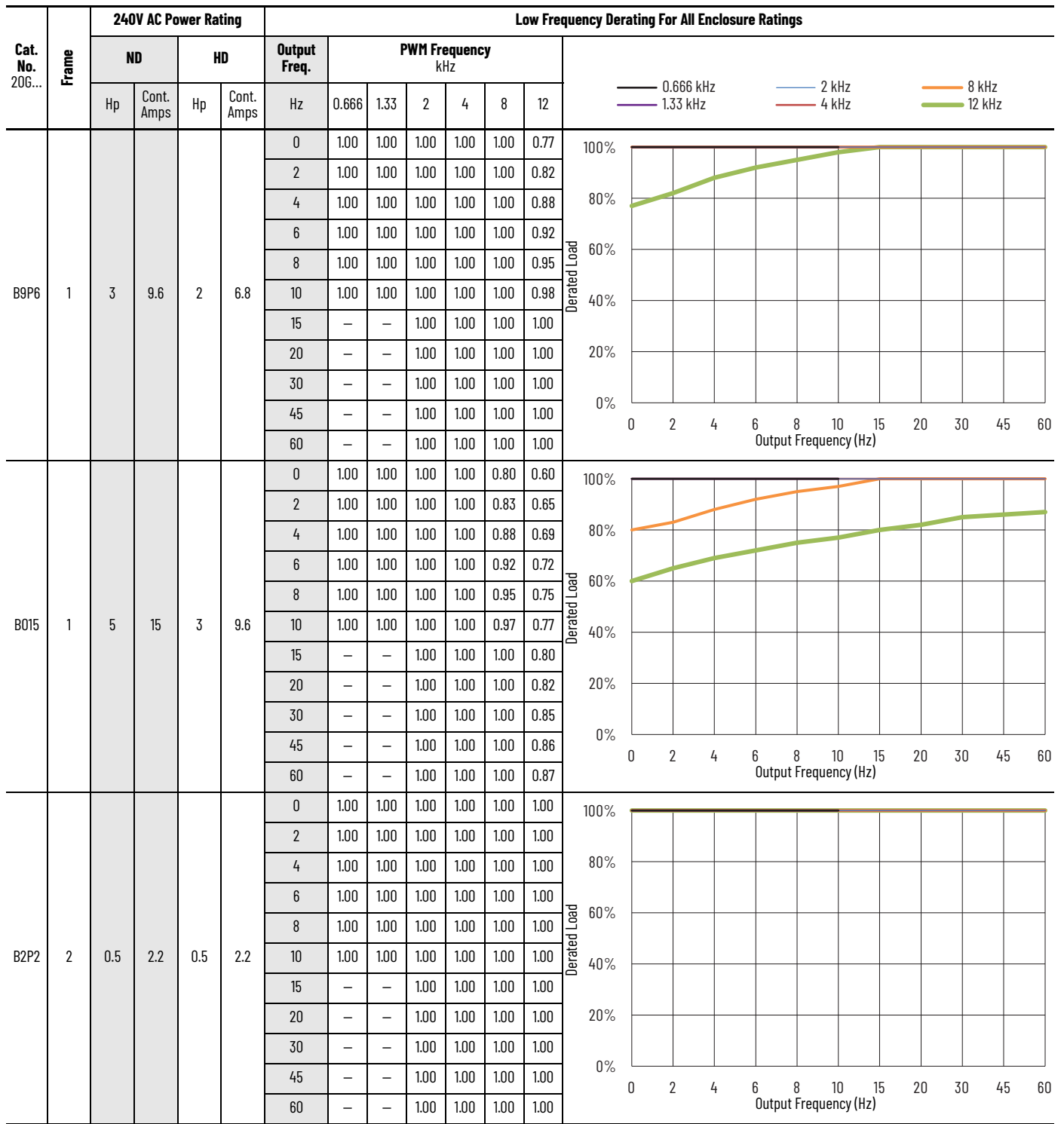

## Low Frequency Derating Curves—240V AC Frames 1..7 (Continued)

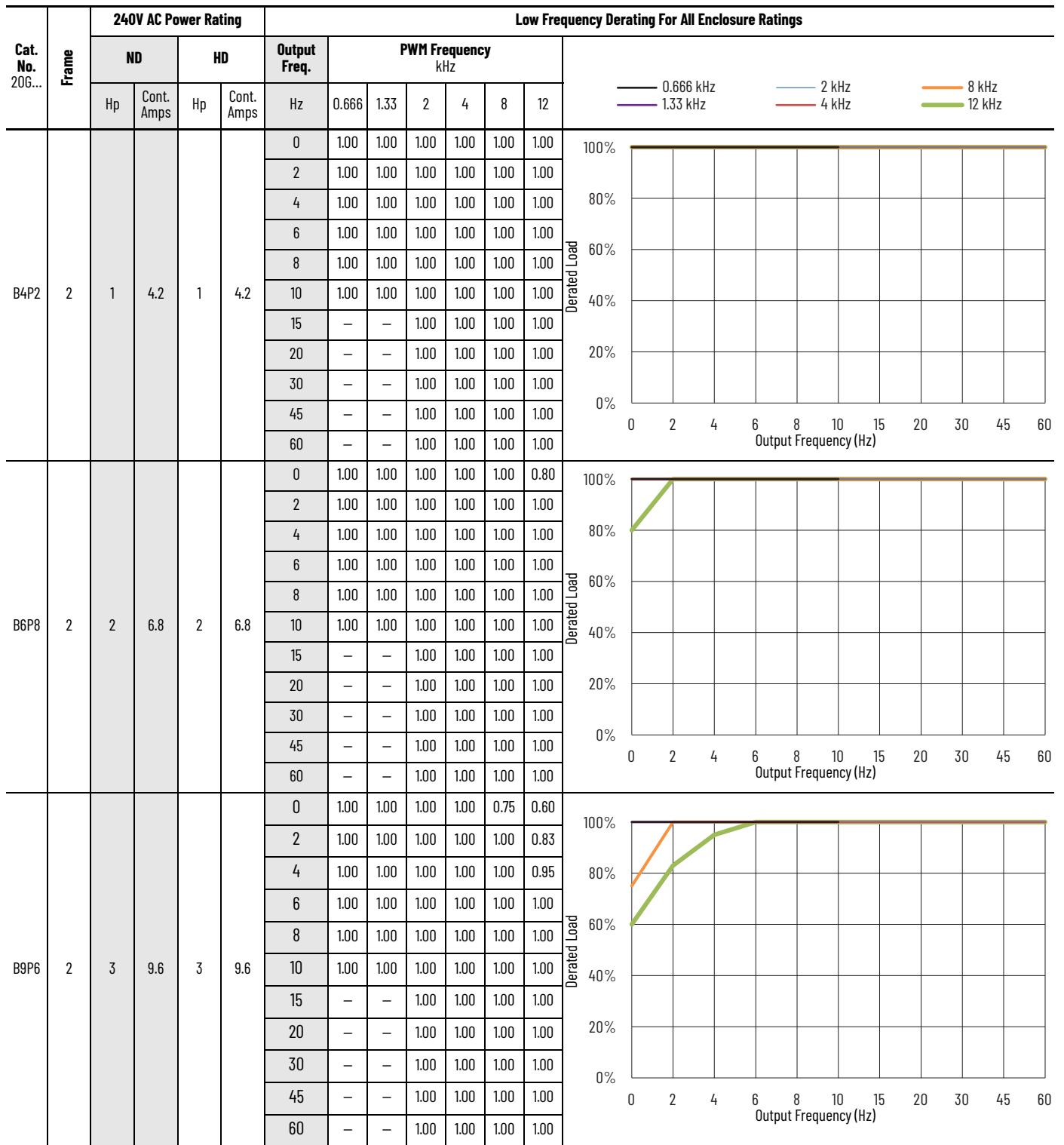

### Low Frequency Derating Curves—240V AC Frames 1..7 (Continued)

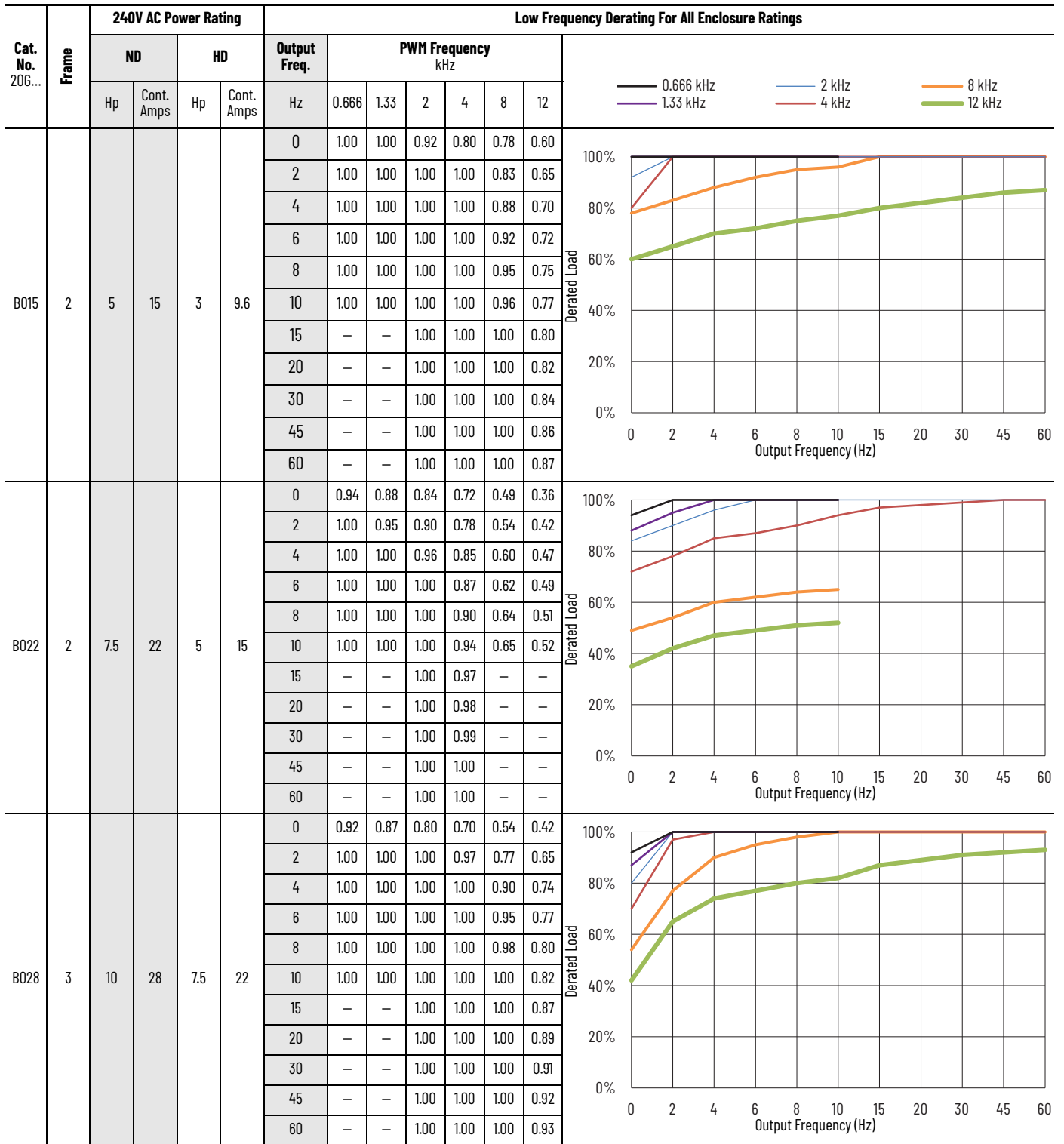

### Low Frequency Derating Curves—240V AC Frames 1..7 (Continued)

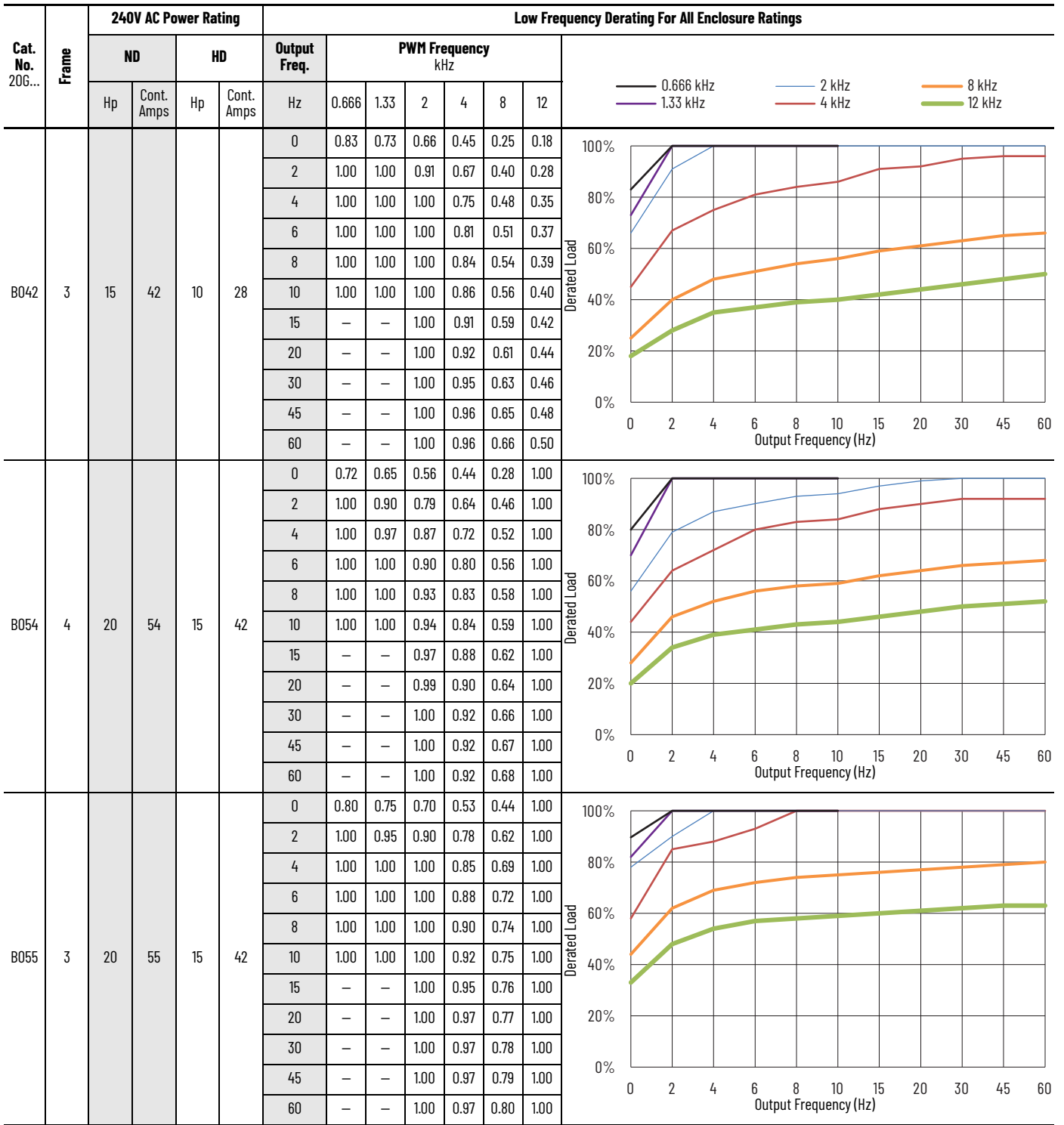

### Low Frequency Derating Curves—240V AC Frames 1..7 (Continued)

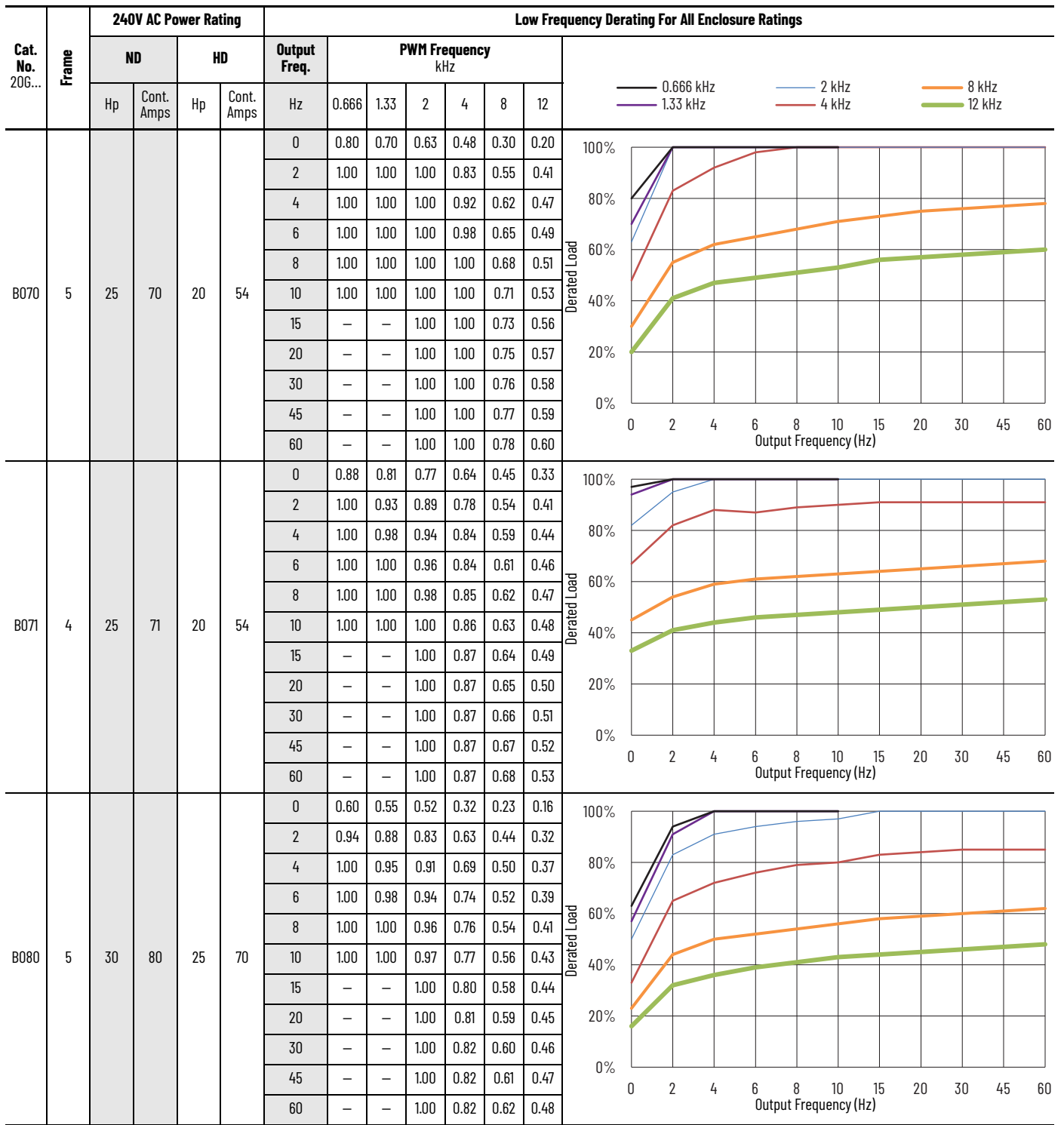

### Low Frequency Derating Curves—240V AC Frames 1...7 (Continued)

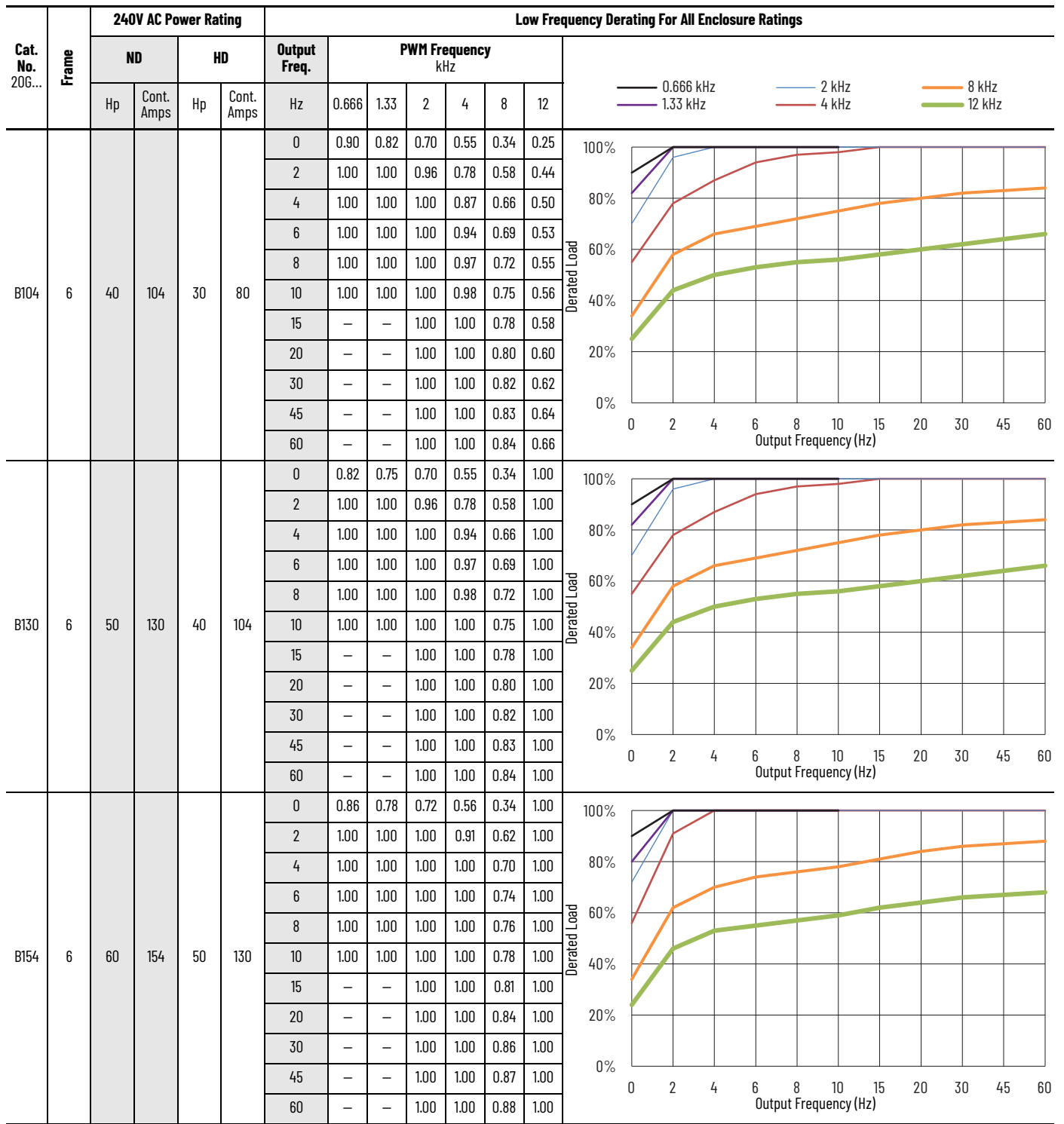

### Low Frequency Derating Curves—240V AC Frames 1...7 (Continued)

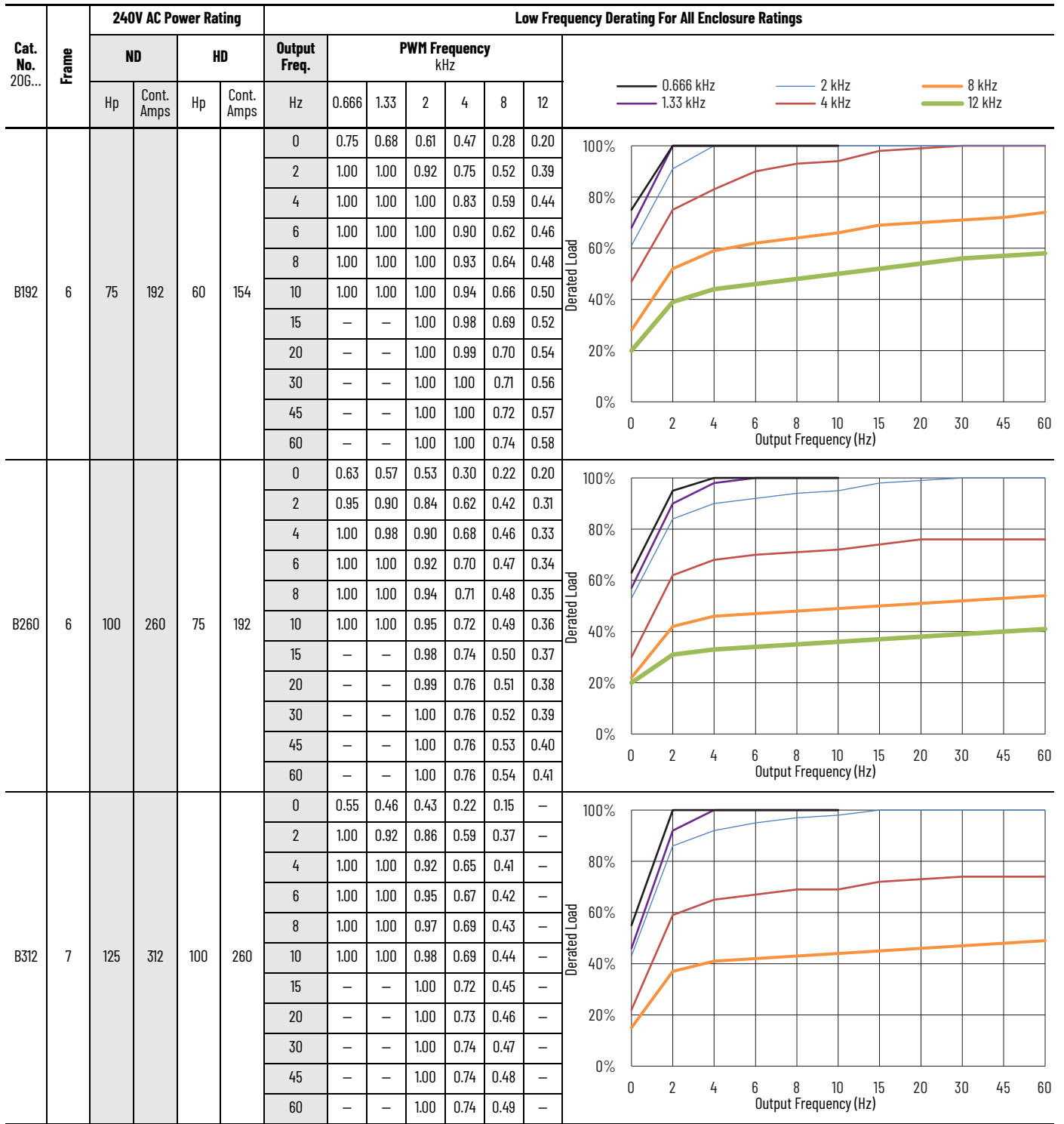

### Low Frequency Derating Curves—240V AC Frames 1..7 (Continued)

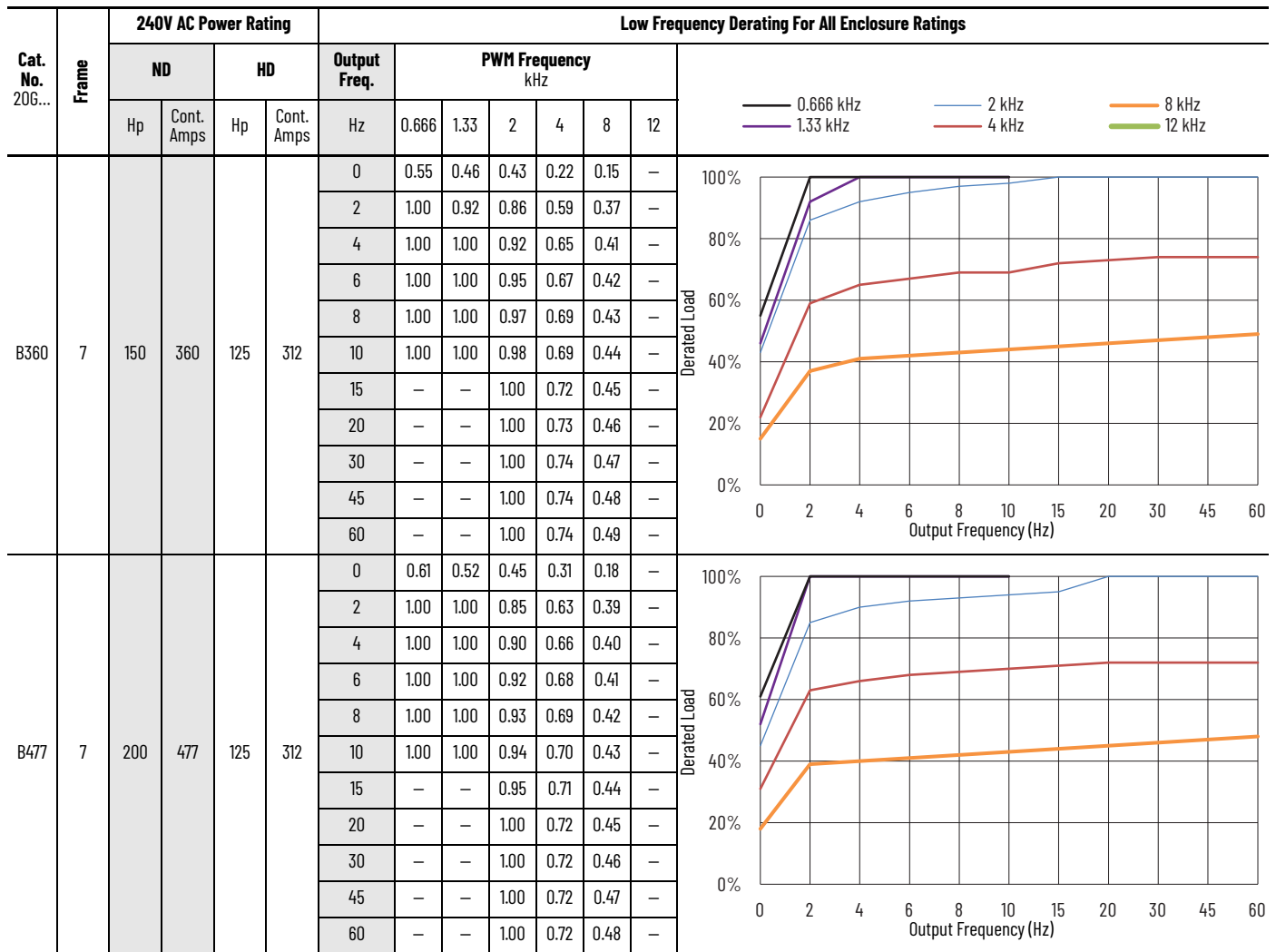

# Low Frequency Derating—400V

The following graphs show the low frequency deratings for 400V PowerFlex 755TS drives specified at the maximum rated ambient temperature at 0 meters altitude.

## Low Frequency Derating Curves—400V AC Frames 1..7

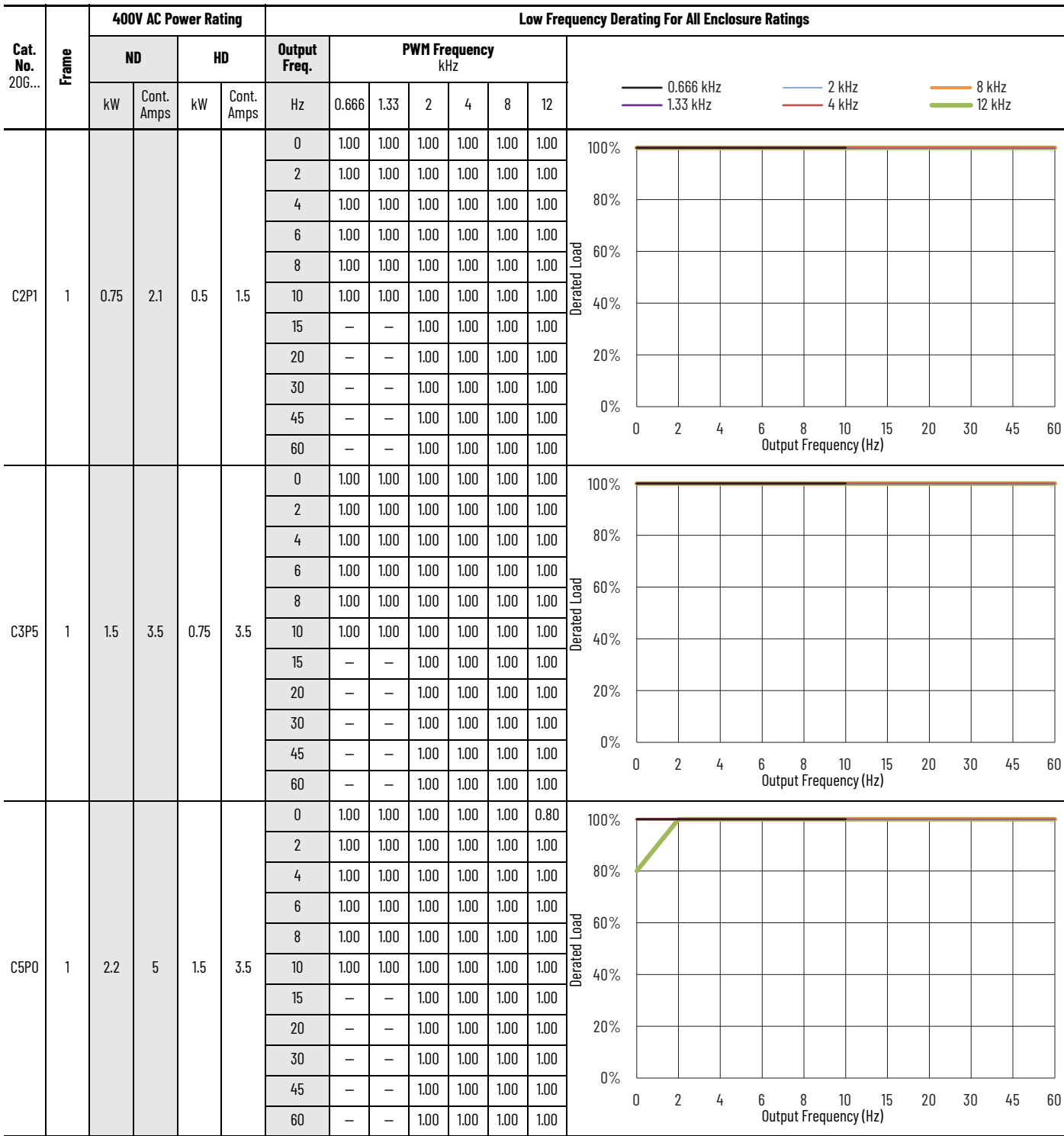

### Low Frequency Derating Curves—400V AC Frames 1..7 (Continued)

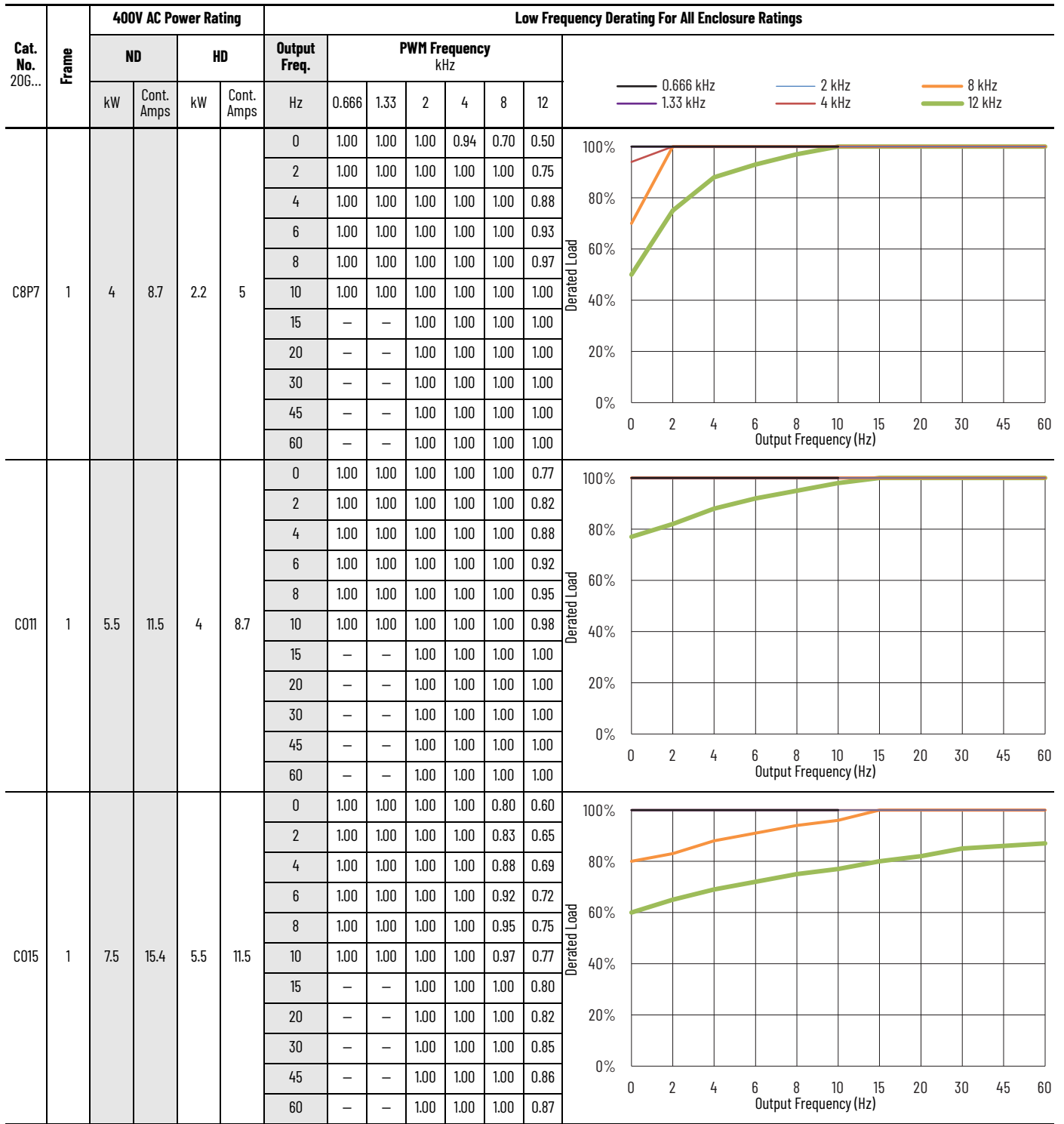

**Low Frequency Derating Curves—400V AC Frames 1...7 (Continued)**

Cat. No. 20G...	Frame	400V AC Power Rating				Low Frequency Derating For All Enclosure Ratings							
		ND		HD		Output Freq.	PWM Frequency kHz						
		kW	Cont. Amps	kW	Cont. Amps	Hz	0.666	1.33	2	4	8	12	
C2P1	2	0.75	2.1	0.5	1.5	0	1.00	1.00	1.00	1.00	1.00	1.00	
						2	1.00	1.00	1.00	1.00	1.00	1.00	
						4	1.00	1.00	1.00	1.00	1.00	1.00	
						6	1.00	1.00	1.00	1.00	1.00	1.00	
						8	1.00	1.00	1.00	1.00	1.00	1.00	
						10	1.00	1.00	1.00	1.00	1.00	1.00	
						15	—	—	1.00	1.00	1.00	1.00	
						20	—	—	1.00	1.00	1.00	1.00	
						30	—	—	1.00	1.00	1.00	1.00	
						45	—	—	1.00	1.00	1.00	1.00	
60	—	—	1.00	1.00	1.00	1.00							
C3P5	2	1.5	3.5	0.75	2.1	0	1.00	1.00	1.00	1.00	1.00	1.00	
						2	1.00	1.00	1.00	1.00	1.00	1.00	
						4	1.00	1.00	1.00	1.00	1.00	1.00	
						6	1.00	1.00	1.00	1.00	1.00	1.00	
						8	1.00	1.00	1.00	1.00	1.00	1.00	
						10	1.00	1.00	1.00	1.00	1.00	1.00	
						15	—	—	1.00	1.00	1.00	1.00	
						20	—	—	1.00	1.00	1.00	1.00	
						30	—	—	1.00	1.00	1.00	1.00	
						45	—	—	1.00	1.00	1.00	1.00	
60	—	—	1.00	1.00	1.00	1.00							
C5P0	2	2.2	5	1.5	3.5	0	1.00	1.00	1.00	1.00	1.00	1.00	
						2	1.00	1.00	1.00	1.00	1.00	1.00	
						4	1.00	1.00	1.00	1.00	1.00	1.00	
						6	1.00	1.00	1.00	1.00	1.00	1.00	
						8	1.00	1.00	1.00	1.00	1.00	1.00	
						10	1.00	1.00	1.00	1.00	1.00	1.00	
						15	—	—	1.00	1.00	1.00	1.00	
						20	—	—	1.00	1.00	1.00	1.00	
						30	—	—	1.00	1.00	1.00	1.00	
						45	—	—	1.00	1.00	1.00	1.00	
60	—	—	1.00	1.00	1.00	1.00							

### Low Frequency Derating Curves—400V AC Frames 1...7 (Continued)

Cat. No. 20G...	Frame	400V AC Power Rating				Low Frequency Derating For All Enclosure Ratings								
		ND		HD		Output Freq. Hz	PWM Frequency kHz							
		kW	Cont. Amps	kW	Cont. Amps		0.666	1.33	2	4	8	12		
C8P7	2	4	8.7	2.2	5	0	1.00	1.00	1.00	1.00	1.00	1.00	0.80	
						2	1.00	1.00	1.00	1.00	1.00	1.00	1.00	
						4	1.00	1.00	1.00	1.00	1.00	1.00	1.00	
						6	1.00	1.00	1.00	1.00	1.00	1.00	1.00	
						8	1.00	1.00	1.00	1.00	1.00	1.00	1.00	
						10	1.00	1.00	1.00	1.00	1.00	1.00	1.00	
						15	—	—	1.00	1.00	1.00	1.00	1.00	
						20	—	—	1.00	1.00	1.00	1.00	1.00	
						30	—	—	1.00	1.00	1.00	1.00	1.00	
						45	—	—	1.00	1.00	1.00	1.00	1.00	
						60	—	—	1.00	1.00	1.00	1.00	1.00	
C011	2	5.5	11.5	4	8.7	0	1.00	1.00	1.00	1.00	1.00	0.75	0.60	
						2	1.00	1.00	1.00	1.00	1.00	1.00	0.83	
						4	1.00	1.00	1.00	1.00	1.00	1.00	0.95	
						6	1.00	1.00	1.00	1.00	1.00	1.00	1.00	
						8	1.00	1.00	1.00	1.00	1.00	1.00	1.00	
						10	1.00	1.00	1.00	1.00	1.00	1.00	1.00	
						15	—	—	1.00	1.00	1.00	1.00	1.00	
						20	—	—	1.00	1.00	1.00	1.00	1.00	
						30	—	—	1.00	1.00	1.00	1.00	1.00	
						45	—	—	1.00	1.00	1.00	1.00	1.00	
						60	—	—	1.00	1.00	1.00	1.00	1.00	
C015	2	7.5	15.4	5.5	11.5	0	1.00	1.00	0.92	0.80	0.78	0.60		
						2	1.00	1.00	1.00	1.00	0.83	0.65		
						4	1.00	1.00	1.00	1.00	0.88	0.70		
						6	1.00	1.00	1.00	1.00	0.92	0.72		
						8	1.00	1.00	1.00	1.00	0.95	0.75		
						10	1.00	1.00	1.00	1.00	0.96	0.77		
						15	—	—	1.00	1.00	1.00	0.80		
						20	—	—	1.00	1.00	1.00	0.82		
						30	—	—	1.00	1.00	1.00	0.84		
						45	—	—	1.00	1.00	1.00	0.86		
						60	—	—	1.00	1.00	1.00	0.87		

### Low Frequency Derating Curves—400V AC Frames 1...7 (Continued)

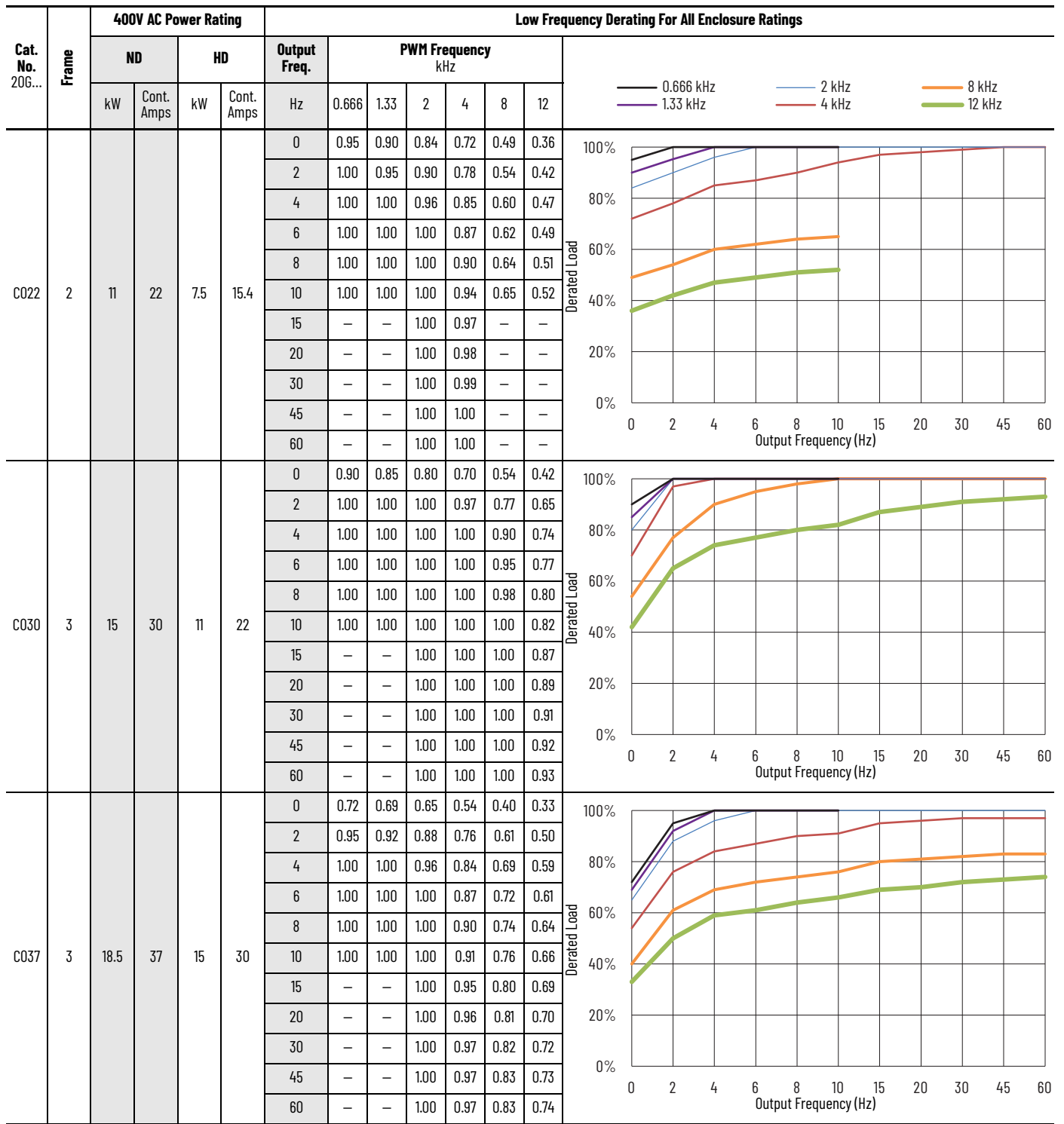

### Low Frequency Derating Curves—400V AC Frames 1...7 (Continued)

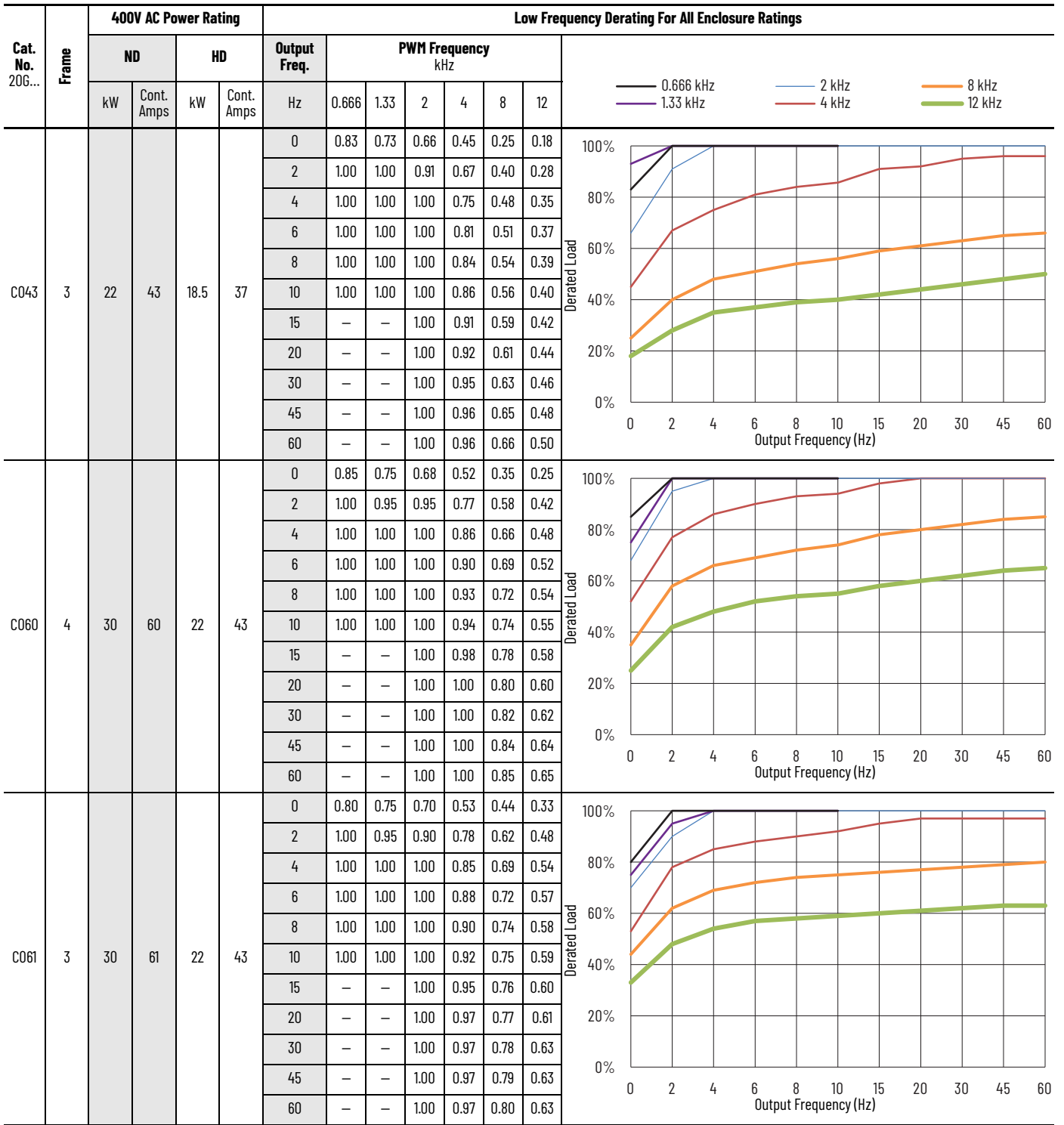

### Low Frequency Derating Curves—400V AC Frames 1...7 (Continued)

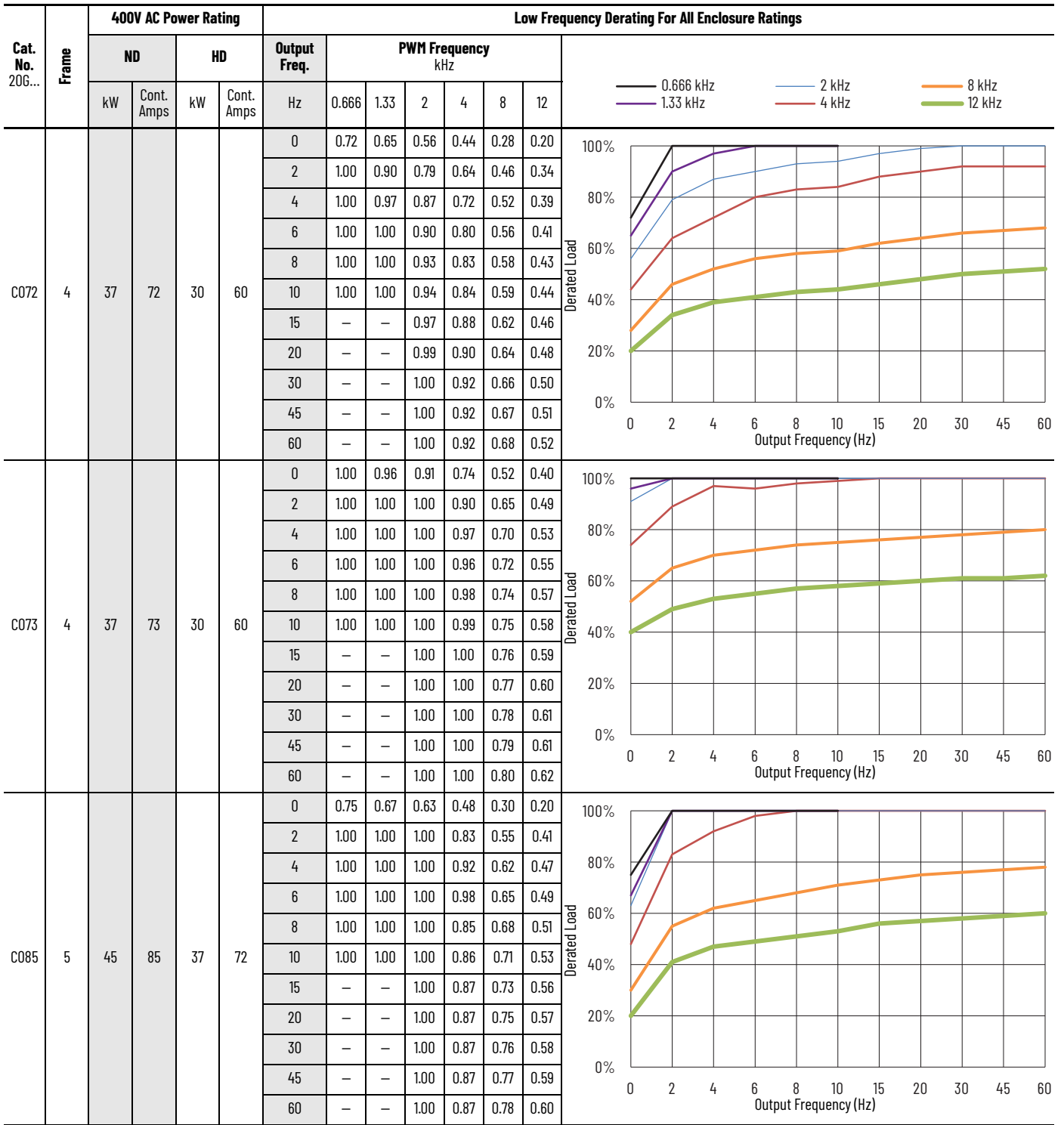

### Low Frequency Derating Curves—400V AC Frames 1...7 (Continued)

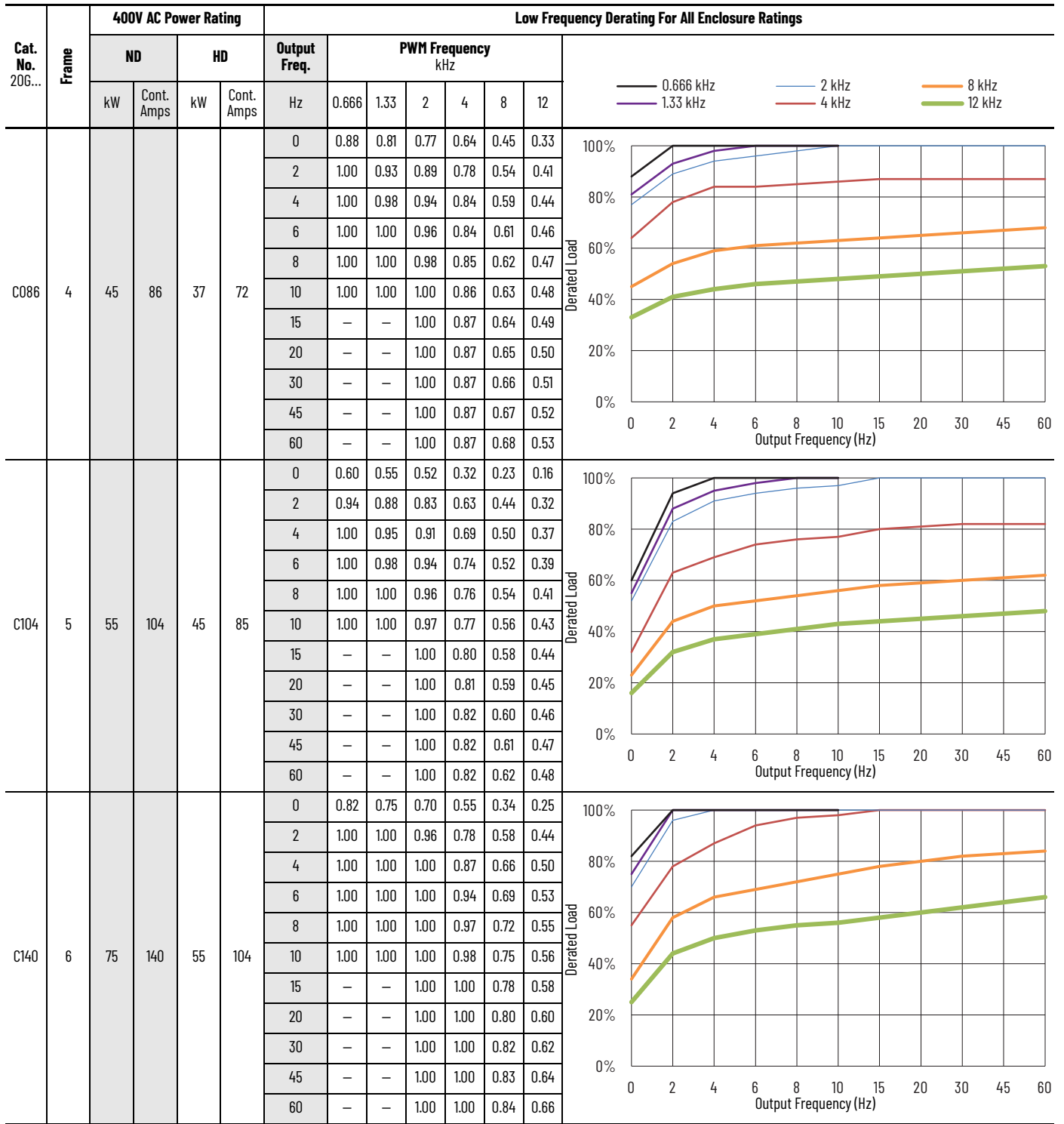

**Low Frequency Derating Curves—400V AC Frames 1...7 (Continued)**

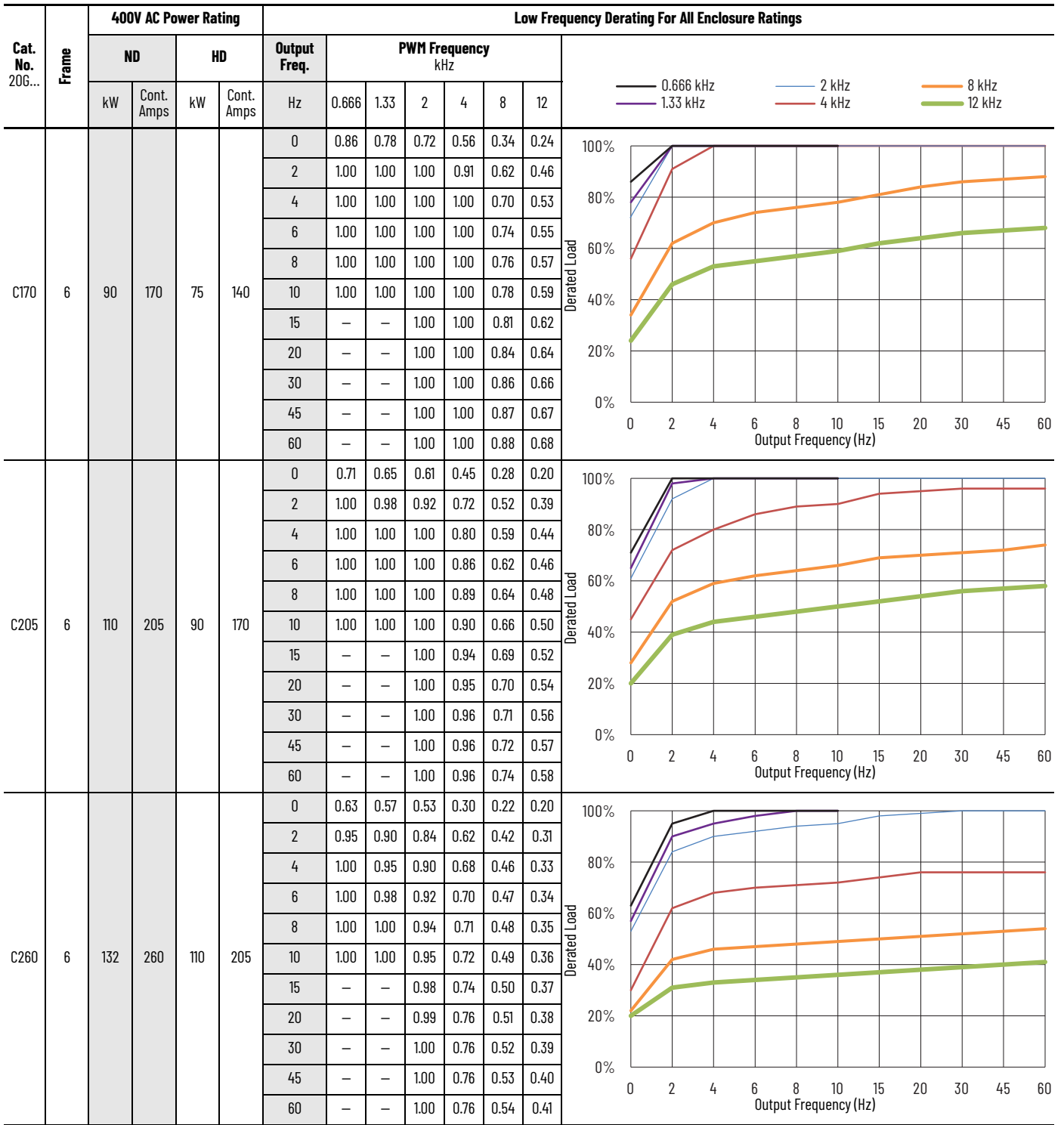

### Low Frequency Derating Curves—400V AC Frames 1...7 (Continued)

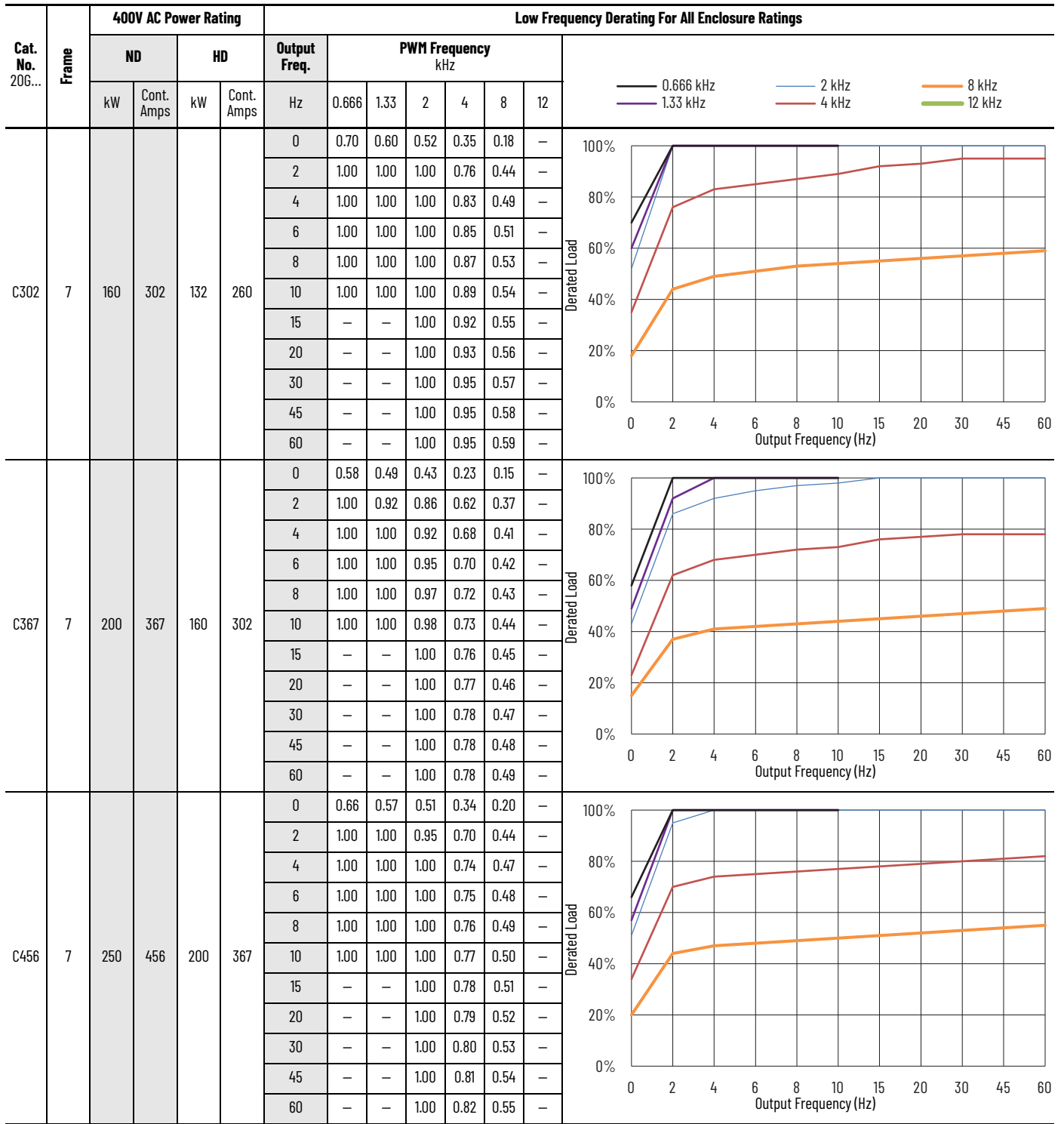

**Low Frequency Derating Curves—400V AC Frames 1..7 (Continued)**

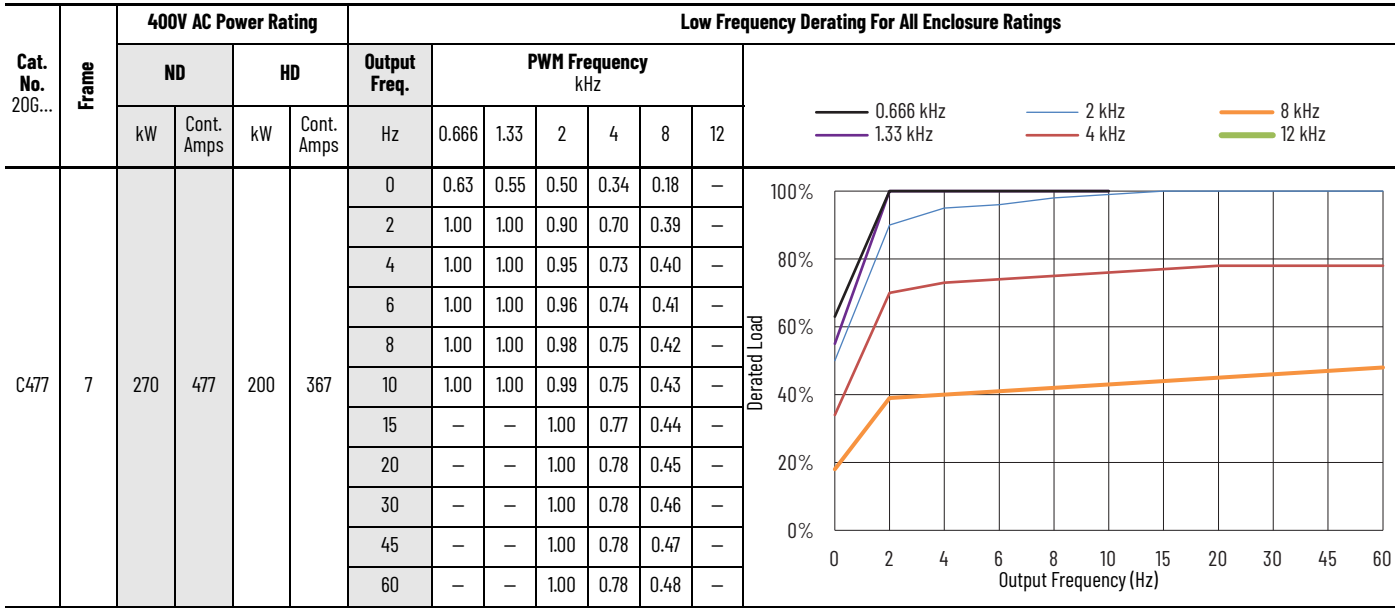

# Low Frequency Derating—480V

The following graphs show the low frequency deratings for 480V PowerFlex 755TS drives specified at the maximum rated ambient temperature at 0 meters altitude.

## Low Frequency Derating Curves—480V AC Frames 1..7

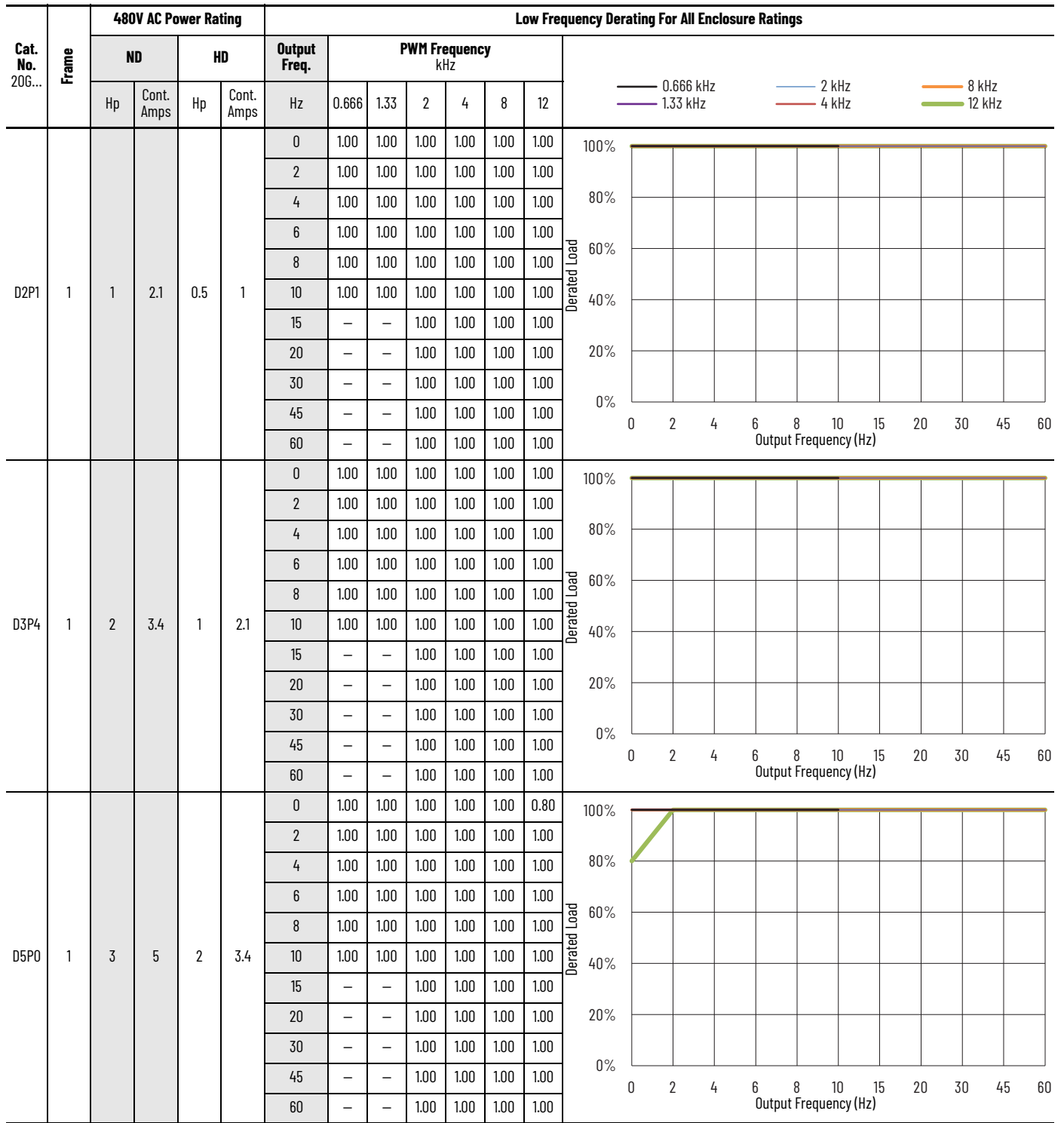

### Low Frequency Derating Curves—480V AC Frames 1..7 (Continued)

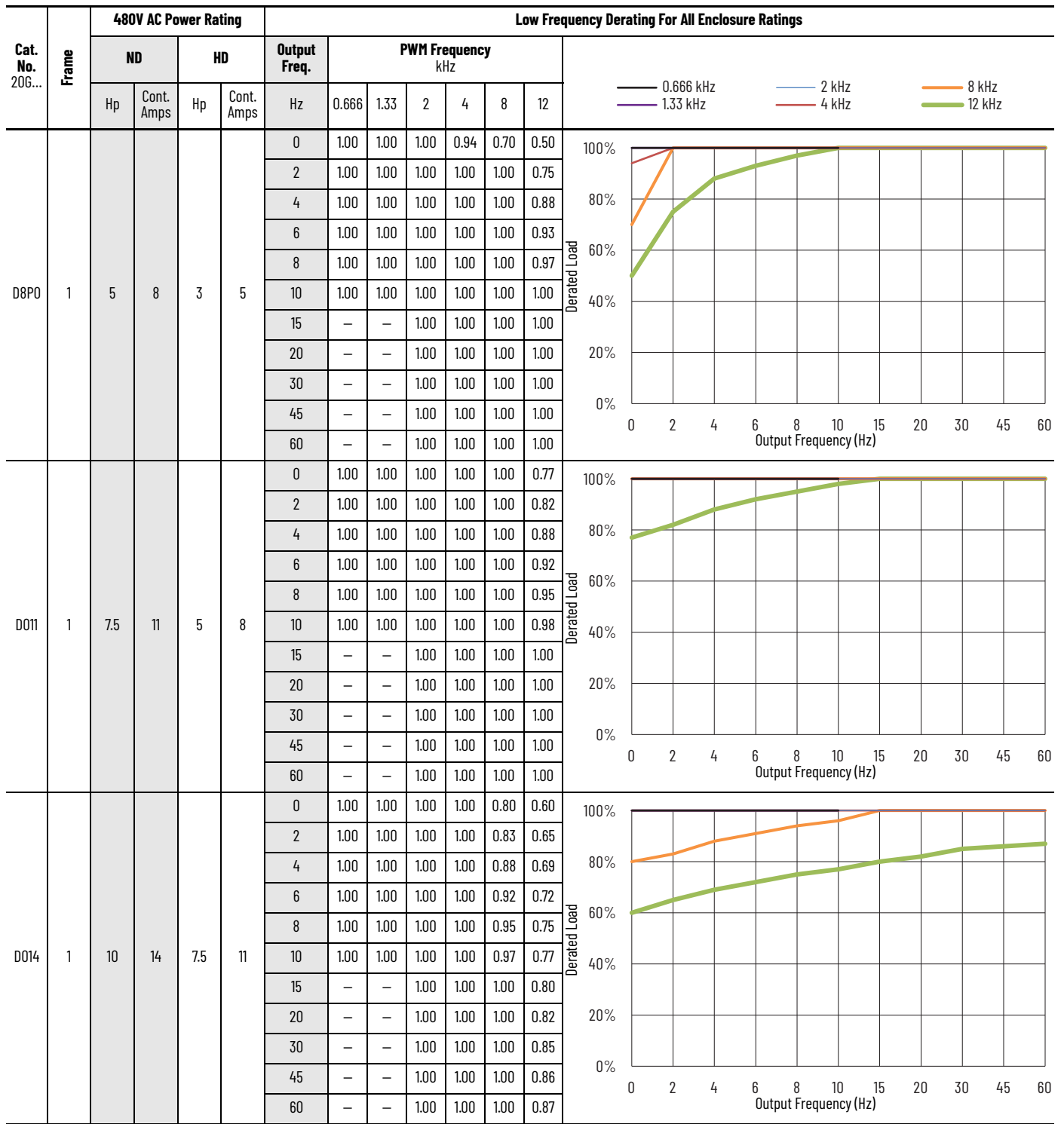

**Low Frequency Derating Curves—480V AC Frames 1..7 (Continued)**

Cat. No. 20G...	Frame	480V AC Power Rating				Low Frequency Derating For All Enclosure Ratings									
		ND		HD		Output Freq. Hz	PWM Frequency kHz								
		Hp	Cont. Amps	Hp	Cont. Amps		0.666	1.33	2	4	8	12			
D2P1	2	1	2.1	0.5	1	0	1.00	1.00	1.00	1.00	1.00	1.00	1.00	1.00	
						2	1.00	1.00	1.00	1.00	1.00	1.00	1.00	1.00	
						4	1.00	1.00	1.00	1.00	1.00	1.00	1.00	1.00	
						6	1.00	1.00	1.00	1.00	1.00	1.00	1.00	1.00	
						8	1.00	1.00	1.00	1.00	1.00	1.00	1.00	1.00	
						10	1.00	1.00	1.00	1.00	1.00	1.00	1.00	1.00	
						15	—	—	1.00	1.00	1.00	1.00	1.00	1.00	
						20	—	—	1.00	1.00	1.00	1.00	1.00	1.00	
						30	—	—	1.00	1.00	1.00	1.00	1.00	1.00	
						45	—	—	1.00	1.00	1.00	1.00	1.00	1.00	
						60	—	—	1.00	1.00	1.00	1.00	1.00	1.00	
D3P4	2	2	3.4	1	2.1	0	1.00	1.00	1.00	1.00	1.00	1.00	1.00		
						2	1.00	1.00	1.00	1.00	1.00	1.00	1.00		1.00
						4	1.00	1.00	1.00	1.00	1.00	1.00	1.00		1.00
						6	1.00	1.00	1.00	1.00	1.00	1.00	1.00		1.00
						8	1.00	1.00	1.00	1.00	1.00	1.00	1.00		1.00
						10	1.00	1.00	1.00	1.00	1.00	1.00	1.00		1.00
						15	—	—	1.00	1.00	1.00	1.00	1.00		1.00
						20	—	—	1.00	1.00	1.00	1.00	1.00		1.00
						30	—	—	1.00	1.00	1.00	1.00	1.00		1.00
						45	—	—	1.00	1.00	1.00	1.00	1.00		1.00
						60	—	—	1.00	1.00	1.00	1.00	1.00		1.00
D5P0	2	3	5	2	3.4	0	1.00	1.00	1.00	1.00	1.00	1.00	1.00		
						2	1.00	1.00	1.00	1.00	1.00	1.00	1.00		1.00
						4	1.00	1.00	1.00	1.00	1.00	1.00	1.00		1.00
						6	1.00	1.00	1.00	1.00	1.00	1.00	1.00		1.00
						8	1.00	1.00	1.00	1.00	1.00	1.00	1.00		1.00
						10	1.00	1.00	1.00	1.00	1.00	1.00	1.00		1.00
						15	—	—	1.00	1.00	1.00	1.00	1.00		1.00
						20	—	—	1.00	1.00	1.00	1.00	1.00		1.00
						30	—	—	1.00	1.00	1.00	1.00	1.00		1.00
						45	—	—	1.00	1.00	1.00	1.00	1.00		1.00
						60	—	—	1.00	1.00	1.00	1.00	1.00		1.00

### Low Frequency Derating Curves—480V AC Frames 1..7 (Continued)

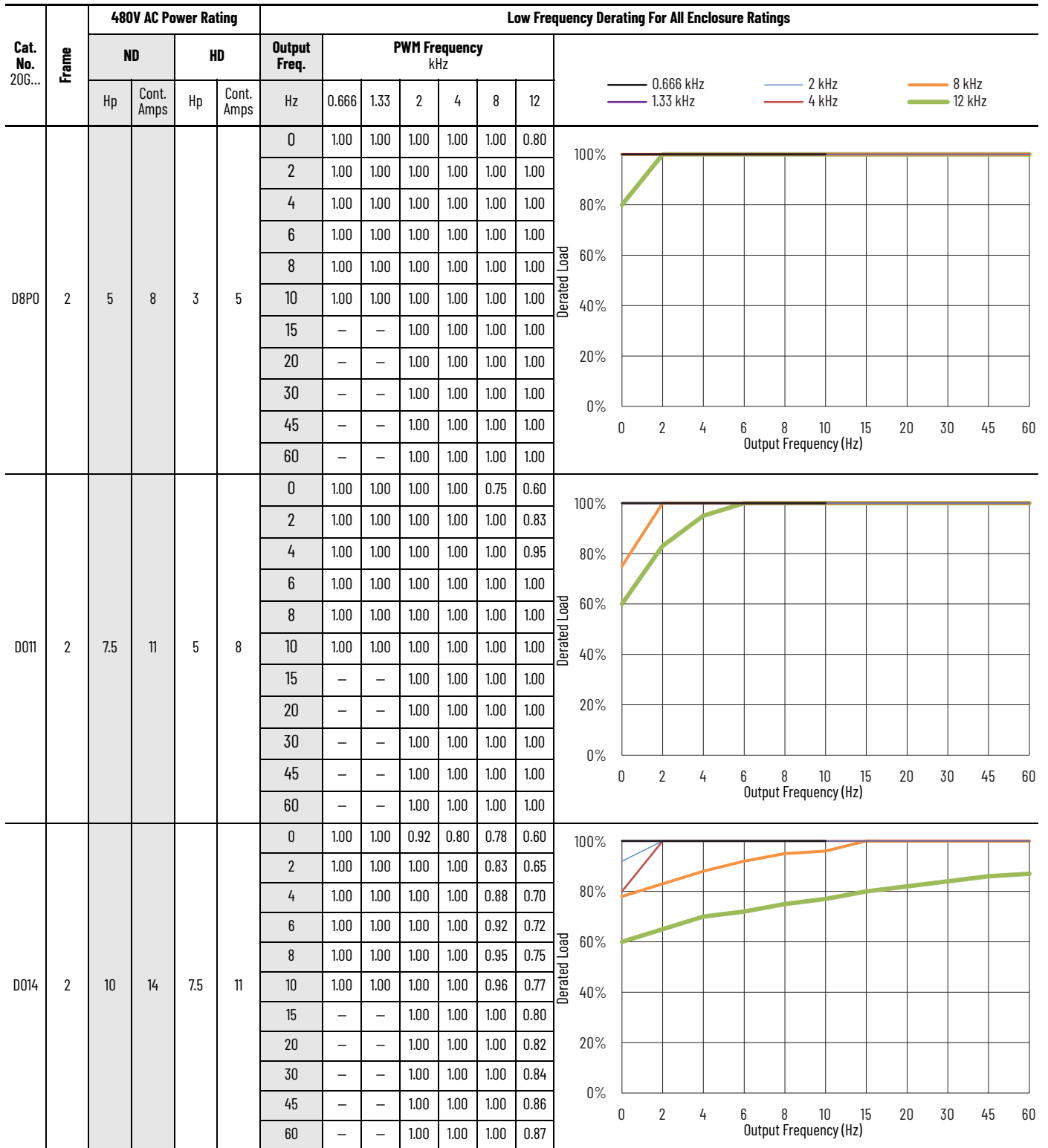

**Low Frequency Derating Curves—480V AC Frames 1...7 (Continued)**

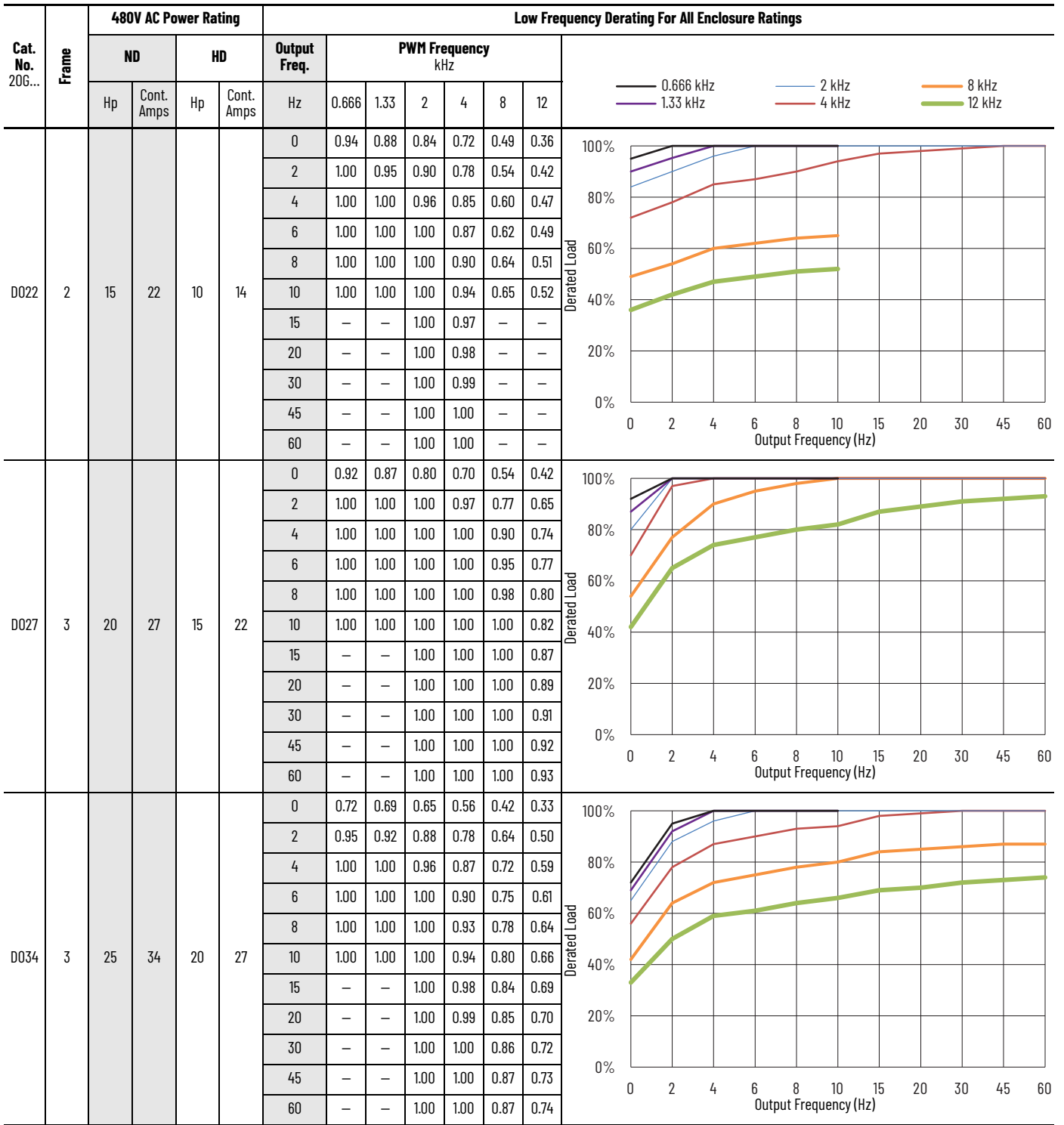

### Low Frequency Derating Curves—480V AC Frames 1...7 (Continued)

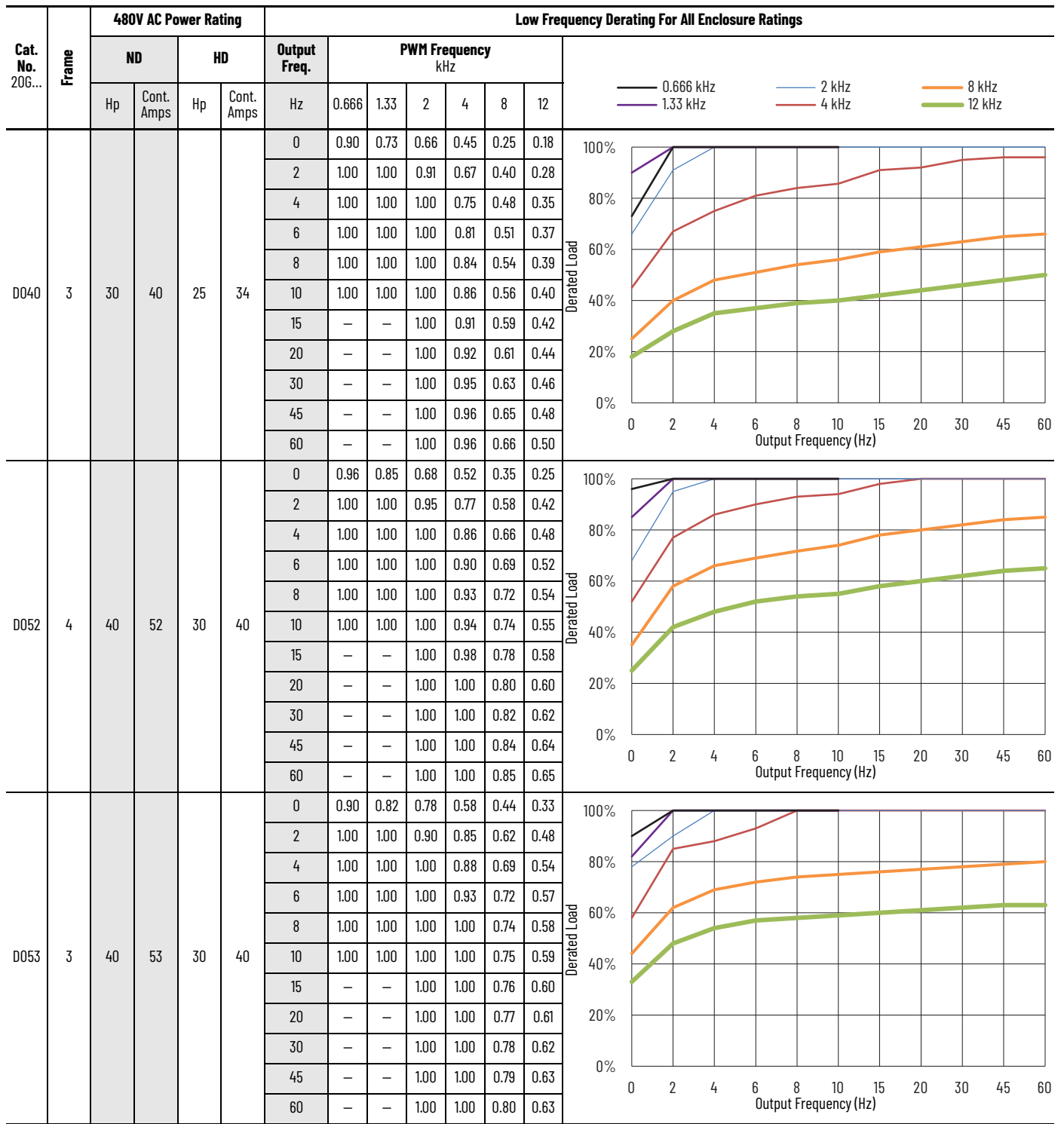

### Low Frequency Derating Curves—480V AC Frames 1...7 (Continued)

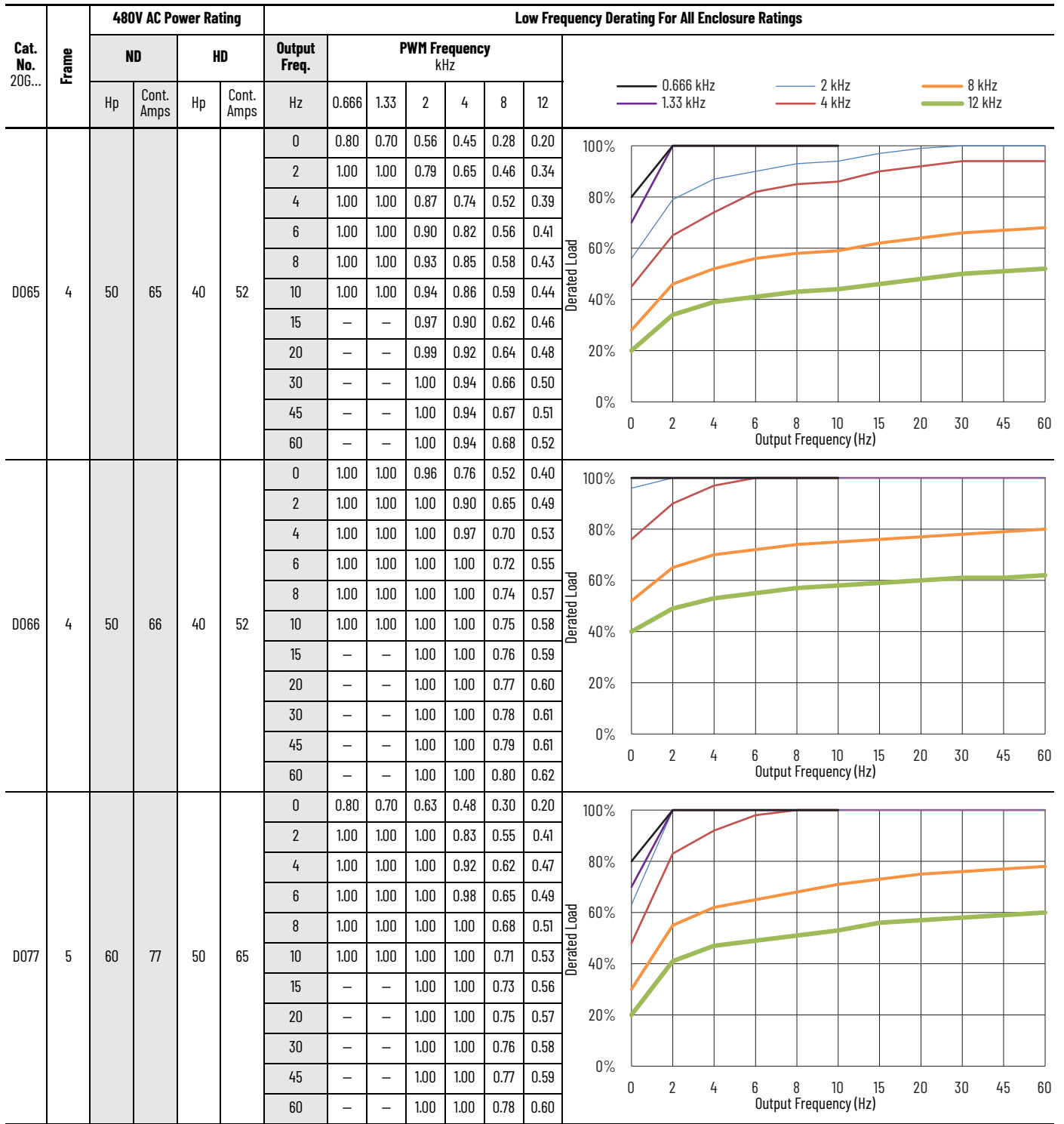

### Low Frequency Derating Curves—480V AC Frames 1...7 (Continued)

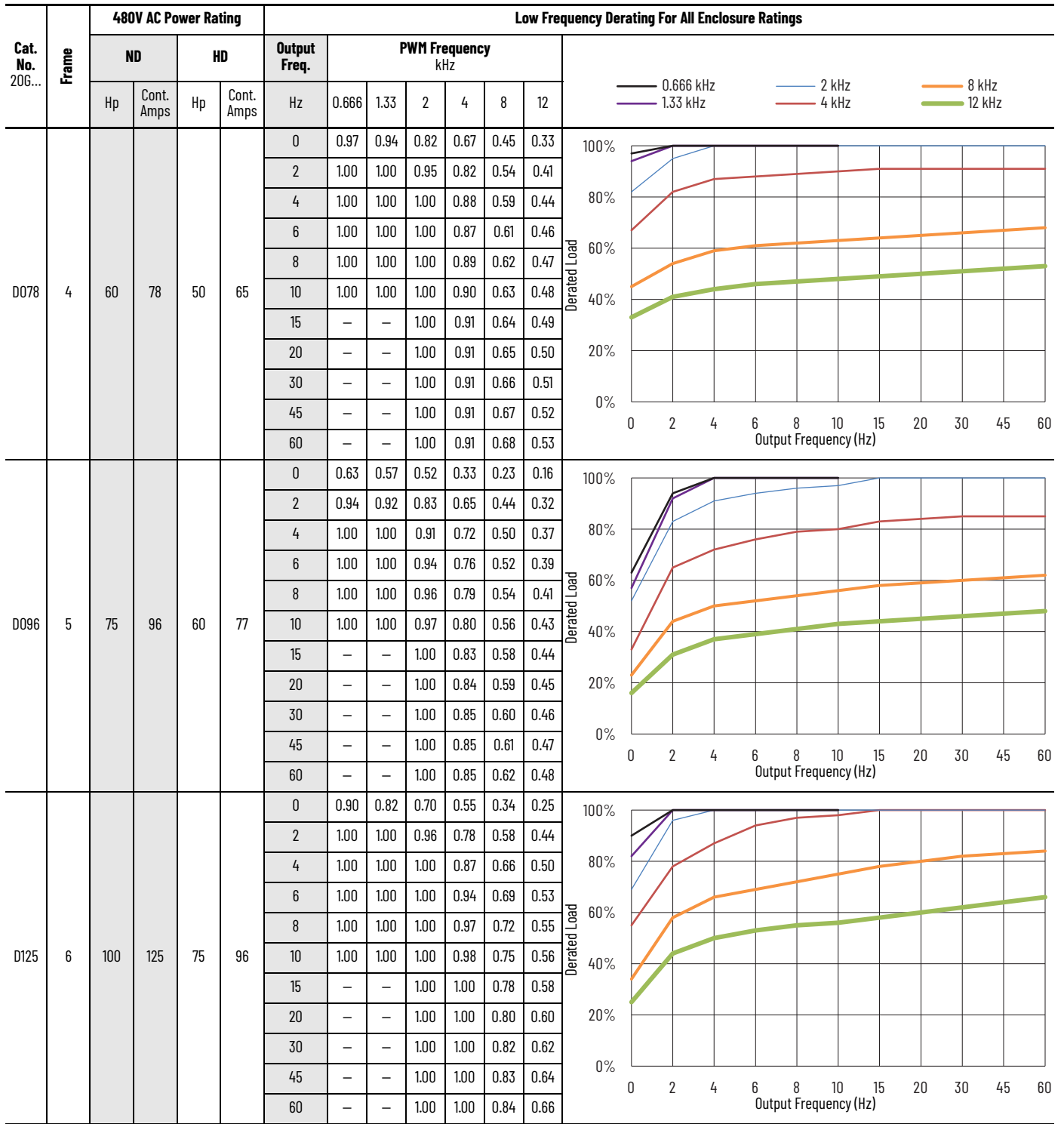

**Low Frequency Derating Curves—480V AC Frames 1...7 (Continued)**

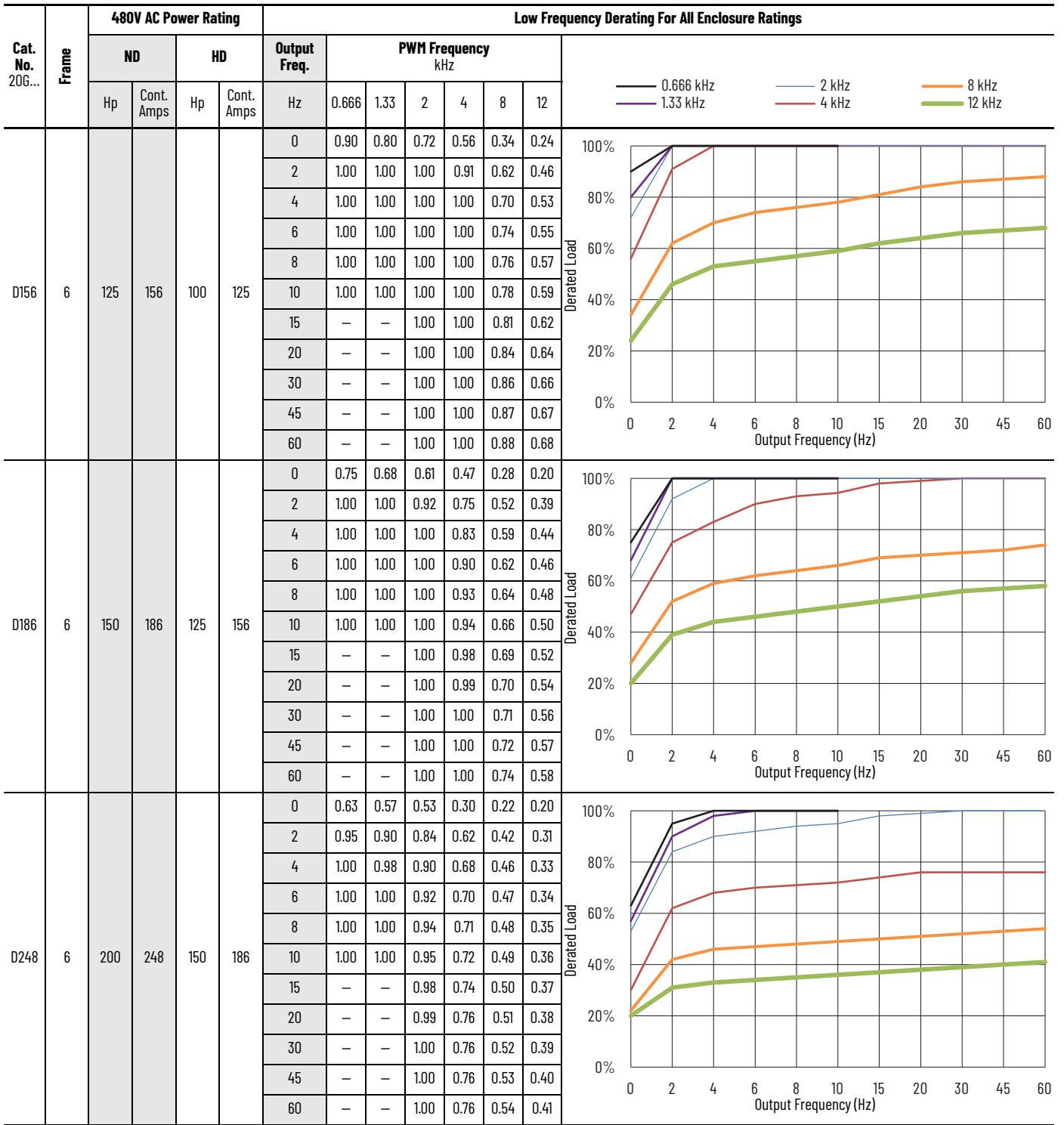

**Low Frequency Derating Curves—480V AC Frames 1...7 (Continued)**

Cat. No. 206...	Frame	480V AC Power Rating				Low Frequency Derating For All Enclosure Ratings							
		ND		HD		Output Freq.	PWM Frequency kHz						
		Hp	Cont. Amps	Hp	Cont. Amps	Hz	0.666	1.33	2	4	8	12	
D302	7	250	302	200	248	0	0.70	0.60	0.52	0.27	0.18	—	
						2	1.00	1.00	1.00	0.71	0.44	—	
						4	1.00	1.00	1.00	0.78	0.49	—	
						6	1.00	1.00	1.00	0.80	0.51	—	
						8	1.00	1.00	1.00	0.82	0.53	—	
						10	1.00	1.00	1.00	0.84	0.54	—	
						15	—	—	1.00	0.87	0.55	—	
						20	—	—	1.00	0.88	0.56	—	
						30	—	—	1.00	0.89	0.57	—	
						45	—	—	1.00	0.89	0.58	—	
60	—	—	1.00	0.89	0.59	—							
D361	7	300	361	250	302	0	0.55	0.46	0.43	0.22	0.15	—	
						2	1.00	0.92	0.86	0.59	0.37	—	
						4	1.00	1.00	0.92	0.65	0.41	—	
						6	1.00	1.00	0.95	0.67	0.42	—	
						8	1.00	1.00	0.97	0.69	0.43	—	
						10	1.00	1.00	0.98	0.69	0.44	—	
						15	—	—	1.00	0.72	0.45	—	
						20	—	—	1.00	0.73	0.46	—	
						30	—	—	1.00	0.74	0.47	—	
						45	—	—	1.00	0.74	0.48	—	
60	—	—	1.00	0.74	0.49	—							
D415	7	350	415	300	361	0	0.66	0.57	0.45	0.34	0.20	—	
						2	1.00	1.00	0.90	0.71	0.44	—	
						4	1.00	1.00	0.95	0.75	0.47	—	
						6	1.00	1.00	0.97	0.76	0.48	—	
						8	1.00	1.00	0.99	0.77	0.49	—	
						10	1.00	1.00	1.00	0.78	0.50	—	
						15	—	—	1.00	0.79	0.51	—	
						20	—	—	1.00	0.80	0.52	—	
						30	—	—	1.00	0.81	0.53	—	
						45	—	—	1.00	0.82	0.54	—	
60	—	—	1.00	0.83	0.55	—							

**Low Frequency Derating Curves—480V AC Frames 1..7 (Continued)**

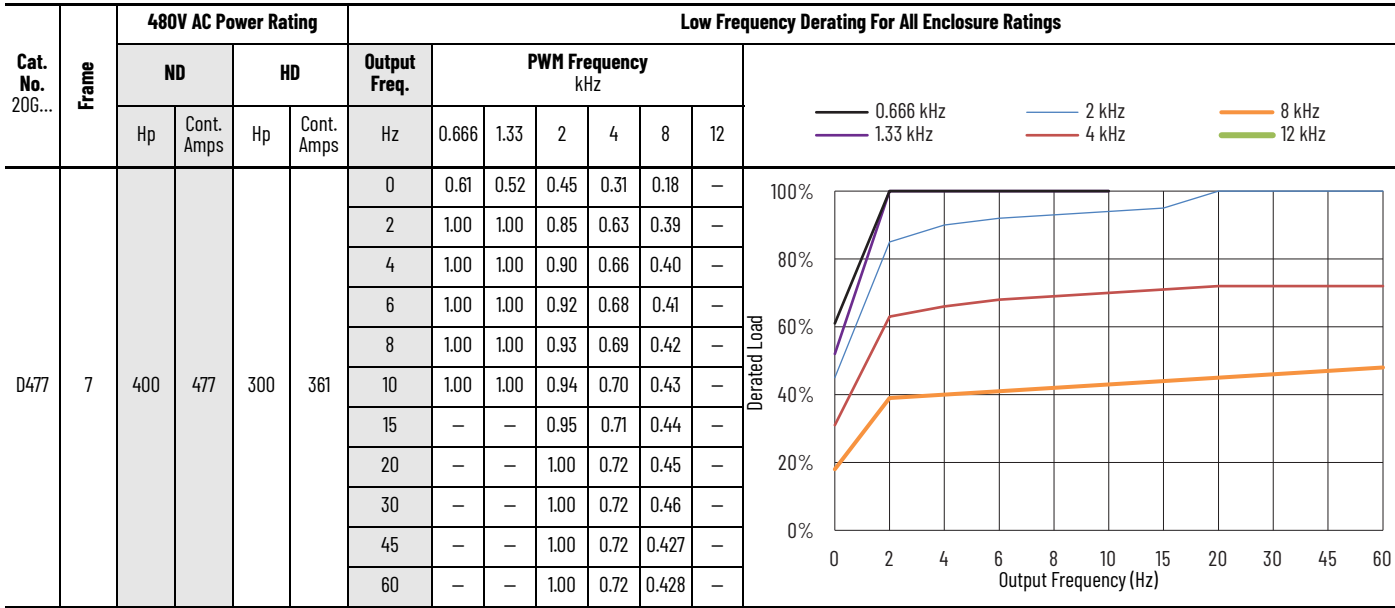

# Low Frequency Derating—600V

The following graphs show the low frequency deratings for 600V PowerFlex 755TS drives specified at the maximum rated ambient temperature at 0 meters altitude.

## Low Frequency Derating Curves—600V AC Frames 3...7

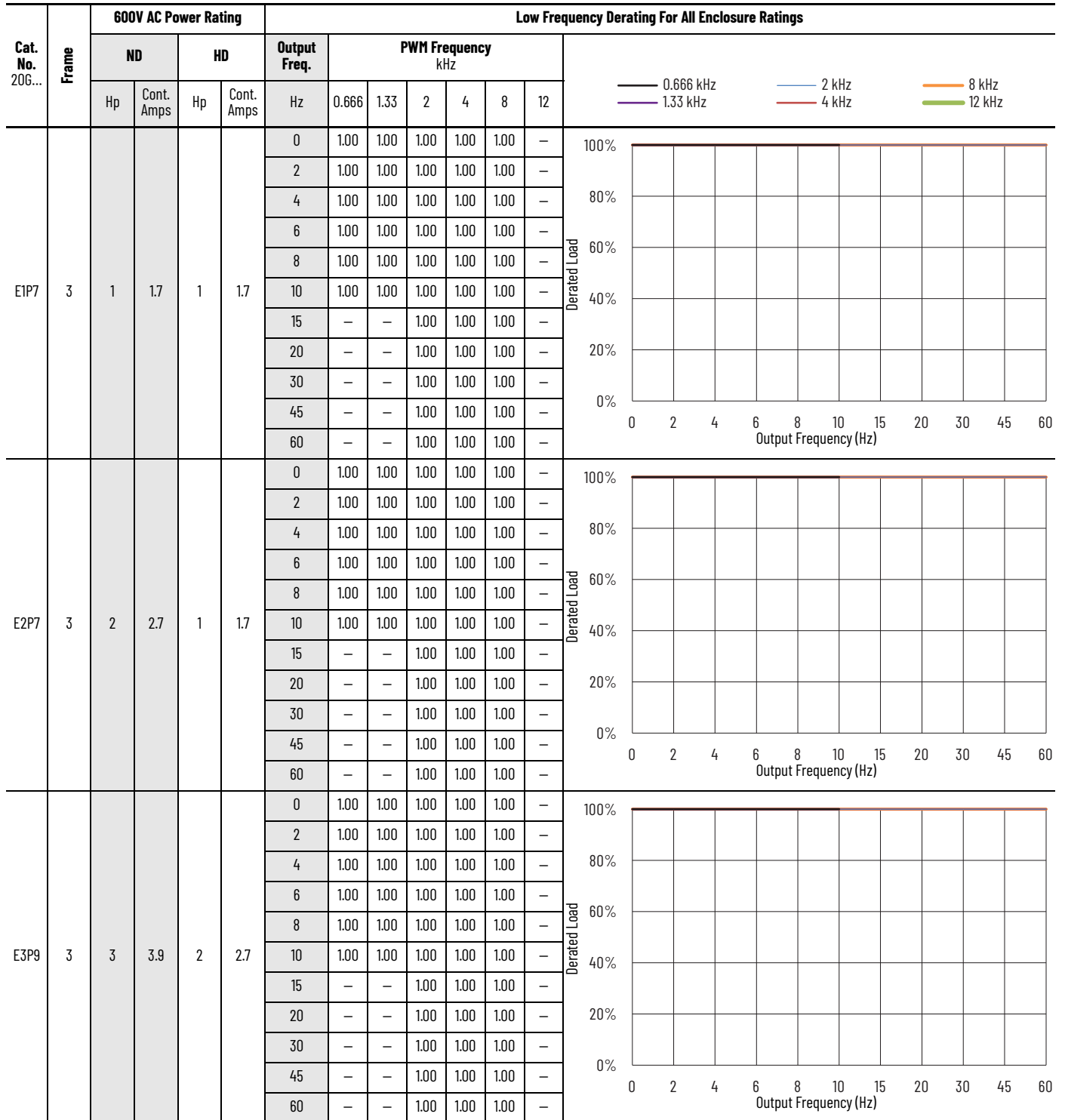

### Low Frequency Derating Curves—600V AC Frames 3...7 (Continued)

Cat. No. 20G...	Frame	600V AC Power Rating				Low Frequency Derating For All Enclosure Ratings							
		ND		HD		Output Freq.	PWM Frequency kHz					Derated Load	
		Hp	Cont. Amps	Hp	Cont. Amps	Hz	0.666	1.33	2	4	8		
E6P1	3	3	3.9	2	2.7	0	1.00	1.00	1.00	1.00	1.00	—	
						2	1.00	1.00	1.00	1.00	1.00	—	
						4	1.00	1.00	1.00	1.00	1.00	—	
						6	1.00	1.00	1.00	1.00	1.00	—	
						8	1.00	1.00	1.00	1.00	1.00	—	
						10	1.00	1.00	1.00	1.00	1.00	—	
						15	—	—	1.00	1.00	1.00	—	
						20	—	—	1.00	1.00	1.00	—	
						30	—	—	1.00	1.00	1.00	—	
						45	—	—	1.00	1.00	1.00	—	
60	—	—	1.00	1.00	1.00	—							
E9P0	3	7.5	9	5	6.1	0	1.00	1.00	1.00	1.00	1.00	—	
						2	1.00	1.00	1.00	1.00	1.00	—	
						4	1.00	1.00	1.00	1.00	1.00	—	
						6	1.00	1.00	1.00	1.00	1.00	—	
						8	1.00	1.00	1.00	1.00	1.00	—	
						10	1.00	1.00	1.00	1.00	1.00	—	
						15	—	—	1.00	1.00	1.00	—	
						20	—	—	1.00	1.00	1.00	—	
						30	—	—	1.00	1.00	1.00	—	
						45	—	—	1.00	1.00	1.00	—	
60	—	—	1.00	1.00	1.00	—							
E011	3	10	11	7.5	9	0	1.00	1.00	1.00	1.00	1.00	—	
						2	1.00	1.00	1.00	1.00	1.00	—	
						4	1.00	1.00	1.00	1.00	1.00	—	
						6	1.00	1.00	1.00	1.00	1.00	—	
						8	1.00	1.00	1.00	1.00	1.00	—	
						10	1.00	1.00	1.00	1.00	1.00	—	
						15	—	—	1.00	1.00	1.00	—	
						20	—	—	1.00	1.00	1.00	—	
						30	—	—	1.00	1.00	1.00	—	
						45	—	—	1.00	1.00	1.00	—	
60	—	—	1.00	1.00	1.00	—							

### Low Frequency Derating Curves—600V AC Frames 3...7 (Continued)

Cat. No. 20G...	Frame	600V AC Power Rating				Low Frequency Derating For All Enclosure Ratings								
		ND		HD		Output Freq. Hz	PWM Frequency kHz					Derated Load		
		Hp	Cont. Amps	Hp	Cont. Amps		0.666	1.33	2	4	8			12
E012	6	10	12	7.5	9.1	0	1.00	1.00	1.00	1.00	—		—	100%
						2	1.00	1.00	1.00	1.00	—	—		
						4	1.00	1.00	1.00	1.00	—	—		
						6	1.00	1.00	1.00	1.00	—	—		
						8	1.00	1.00	1.00	1.00	—	—		
						10	1.00	1.00	1.00	1.00	—	—		
						15	—	—	1.00	1.00	—	—		
						20	—	—	1.00	1.00	—	—		
						30	—	—	1.00	1.00	—	—		
						45	—	—	1.00	1.00	—	—		
60	—	—	1.00	1.00	—	—								
E017	3	15	17	10	11	0	1.00	1.00	1.00	0.73	0.42	—		
						2	1.00	1.00	1.00	0.86	0.52	—		
						4	1.00	1.00	1.00	1.00	0.61	—		
						6	1.00	1.00	1.00	1.00	0.64	—		
						8	1.00	1.00	1.00	1.00	0.68	—		
						10	1.00	1.00	1.00	1.00	0.70	—		
						15	—	—	1.00	1.00	0.78	—		
						20	—	—	1.00	1.00	0.81	—		
						30	—	—	1.00	1.00	0.85	—		
						45	—	—	1.00	1.00	0.88	—		
60	—	—	1.00	1.00	0.89	—								
E018	6	15	18	10	12	0	1.00	1.00	1.00	1.00	—	—		
						2	1.00	1.00	1.00	1.00	—	—		
						4	1.00	1.00	1.00	1.00	—	—		
						6	1.00	1.00	1.00	1.00	—	—		
						8	1.00	1.00	1.00	1.00	—	—		
						10	1.00	1.00	1.00	1.00	—	—		
						15	—	—	1.00	1.00	—	—		
						20	—	—	1.00	1.00	—	—		
						30	—	—	1.00	1.00	—	—		
						45	—	—	1.00	1.00	—	—		
60	—	—	1.00	1.00	—	—								

### Low Frequency Derating Curves—600V AC Frames 3...7 (Continued)

Cat. No. 206...	Frame	600V AC Power Rating				Low Frequency Derating For All Enclosure Ratings							
		ND		HD		Output Freq. Hz	PWM Frequency kHz						
		Hp	Cont. Amps	Hp	Cont. Amps		0.666	1.33	2	4	8	12	
E022	3	20	22	15	17	0	1.00	1.00	0.91	0.58	0.33	—	
						2	1.00	1.00	1.00	0.67	0.42	—	
						4	1.00	1.00	1.00	0.77	0.50	—	
						6	1.00	1.00	1.00	0.85	0.53	—	
						8	1.00	1.00	1.00	0.89	0.56	—	
						10	1.00	1.00	1.00	0.91	0.57	—	
						15	—	—	1.00	0.97	0.61	—	
						20	—	—	1.00	1.00	0.62	—	
						30	—	—	1.00	1.00	0.66	—	
						45	—	—	1.00	1.00	0.68	—	
						60	—	—	1.00	1.00	0.70	—	
E023	6	20	23	15	18	0	1.00	1.00	1.00	1.00	—	—	
						2	1.00	1.00	1.00	1.00	—	—	
						4	1.00	1.00	1.00	1.00	—	—	
						6	1.00	1.00	1.00	1.00	—	—	
						8	1.00	1.00	1.00	1.00	—	—	
						10	1.00	1.00	1.00	1.00	—	—	
						15	—	—	1.00	1.00	—	—	
						20	—	—	1.00	1.00	—	—	
						30	—	—	1.00	1.00	—	—	
						45	—	—	1.00	1.00	—	—	
						60	—	—	1.00	1.00	—	—	
E024	6	20	24	20	22	0	1.00	1.00	1.00	1.00	—	—	
						2	1.00	1.00	1.00	1.00	—	—	
						4	1.00	1.00	1.00	1.00	—	—	
						6	1.00	1.00	1.00	1.00	—	—	
						8	1.00	1.00	1.00	1.00	—	—	
						10	1.00	1.00	1.00	1.00	—	—	
						15	—	—	1.00	1.00	—	—	
						20	—	—	1.00	1.00	—	—	
						30	—	—	1.00	1.00	—	—	
						45	—	—	1.00	1.00	—	—	
						60	—	—	1.00	1.00	—	—	

### Low Frequency Derating Curves—600V AC Frames 3...7 (Continued)

Cat. No. 206...	Frame	600V AC Power Rating				Low Frequency Derating For All Enclosure Ratings							
		ND		HD		Output Freq. Hz	PWM Frequency kHz						
		Hp	Cont. Amps	Hp	Cont. Amps		0.666	1.33	2	4	8	12	
E027	4	25	27	20	22	0	1.00	1.00	0.84	0.50	0.28	—	
						2	1.00	1.00	1.00	0.77	0.43	—	
						4	1.00	1.00	1.00	0.86	0.49	—	
						6	1.00	1.00	1.00	0.90	0.51	—	
						8	1.00	1.00	1.00	0.94	0.53	—	
						10	1.00	1.00	1.00	0.95	0.55	—	
						15	—	—	1.00	1.00	0.58	—	
						20	—	—	1.00	1.00	0.60	—	
						30	—	—	1.00	1.00	0.62	—	
						45	—	—	1.00	1.00	0.64	—	
60	—	—	1.00	1.00	0.65	—							
E028	6	25	28	20	23	0	1.00	1.00	1.00	1.00	—	—	
						2	1.00	1.00	1.00	1.00	—	—	
						4	1.00	1.00	1.00	1.00	—	—	
						6	1.00	1.00	1.00	1.00	—	—	
						8	1.00	1.00	1.00	1.00	—	—	
						10	1.00	1.00	1.00	1.00	—	—	
						15	—	—	1.00	1.00	—	—	
						20	—	—	1.00	1.00	—	—	
						30	—	—	1.00	1.00	—	—	
						45	—	—	1.00	1.00	—	—	
60	—	—	1.00	1.00	—	—							
E032	4	30	32	25	27	0	1.00	0.90	0.72	0.43	0.23	—	
						2	1.00	1.00	0.93	0.65	0.36	—	
						4	1.00	1.00	1.00	0.73	0.41	—	
						6	1.00	1.00	1.00	0.76	0.43	—	
						8	1.00	1.00	1.00	0.79	0.45	—	
						10	1.00	1.00	1.00	0.80	0.47	—	
						15	—	—	—	0.84	0.49	—	
						20	—	—	—	0.86	0.50	—	
						30	—	—	—	0.89	0.52	—	
						45	—	—	—	0.91	0.53	—	
60	—	—	—	0.92	0.54	—							

### Low Frequency Derating Curves—600V AC Frames 3...7 (Continued)

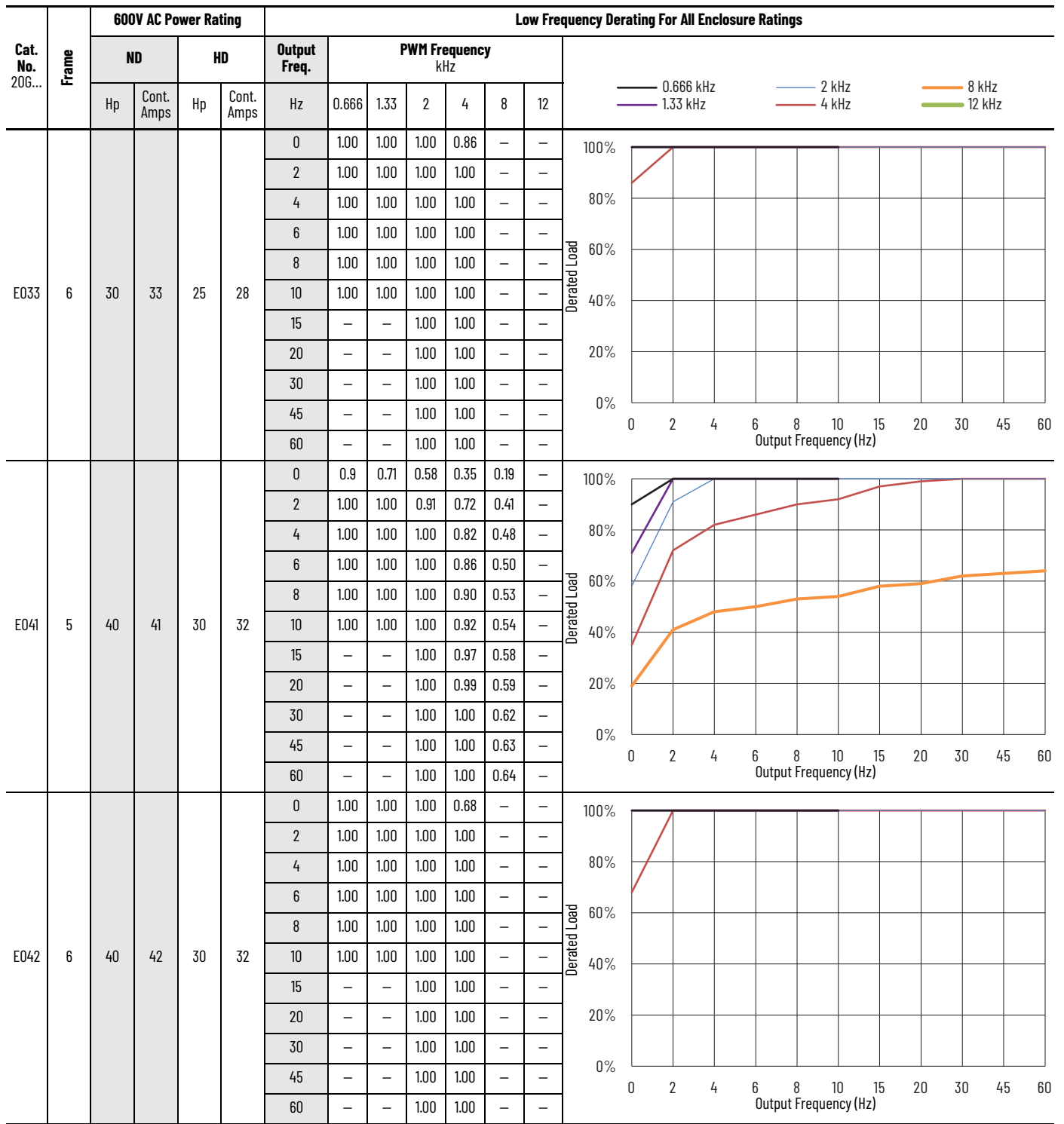

### Low Frequency Derating Curves—600V AC Frames 3...7 (Continued)

Cat. No. 206...	Frame	600V AC Power Rating				Low Frequency Derating For All Enclosure Ratings							
		ND		HD		Output Freq. Hz	PWM Frequency kHz						
		Hp	Cont. Amps	Hp	Cont. Amps		0.666	1.33	2	4	8	12	
E052	5	50	52	40	41	0	0.72	0.56	0.45	0.28	0.15	—	
						2	1.00	1.00	0.72	0.57	0.33	—	
						4	1.00	1.00	0.80	0.64	0.38	—	
						6	1.00	1.00	0.84	0.68	0.40	—	
						8	1.00	1.00	0.87	0.71	0.42	—	
						10	1.00	1.00	0.89	0.72	0.43	—	
						15	—	—	0.93	0.76	0.46	—	
						20	—	—	1.00	0.78	0.47	—	
						30	—	—	1.00	0.81	0.49	—	
						45	—	—	1.00	0.82	0.50	—	
60	—	—	1.00	0.83	0.51	—							
E053	6	50	53	40	42	0	1.00	1.00	0.88	0.54	—	—	
						2	1.00	1.00	1.00	1.00	—	—	
						4	1.00	1.00	1.00	1.00	—	—	
						6	1.00	1.00	1.00	1.00	—	—	
						8	1.00	1.00	1.00	1.00	—	—	
						10	1.00	1.00	1.00	1.00	—	—	
						15	—	—	1.00	1.00	—	—	
						20	—	—	1.00	1.00	—	—	
						30	—	—	1.00	1.00	—	—	
						45	—	—	1.00	1.00	—	—	
60	—	—	1.00	1.00	—	—							
E063	6	60	63	50	52	0	1.00	1.00	1.00	0.85	—	—	
						2	1.00	1.00	1.00	1.00	—	—	
						4	1.00	1.00	1.00	1.00	—	—	
						6	1.00	1.00	1.00	1.00	—	—	
						8	1.00	1.00	1.00	1.00	—	—	
						10	1.00	1.00	1.00	1.00	—	—	
						15	—	—	1.00	1.00	—	—	
						20	—	—	1.00	1.00	—	—	
						30	—	—	1.00	1.00	—	—	
						45	—	—	1.00	1.00	—	—	
60	—	—	1.00	1.00	—	—							

### Low Frequency Derating Curves—600V AC Frames 3...7 (Continued)

Cat. No. 206...	Frame	600V AC Power Rating				Low Frequency Derating For All Enclosure Ratings							
		ND		HD		Output Freq. Hz	PWM Frequency kHz					Derated Load	
		Hp	Cont. Amps	Hp	Cont. Amps		0.666	1.33	2	4	8		
E077	6	75	77	60	63	0	1.00	1.00	1.00	0.70	—		—
						2	1.00	1.00	1.00	0.98	—	—	
						4	1.00	1.00	1.00	1.00	—	—	
						6	1.00	1.00	1.00	1.00	—	—	
						8	1.00	1.00	1.00	1.00	—	—	
						10	1.00	1.00	1.00	1.00	—	—	
						15	—	—	1.00	1.00	—	—	
						20	—	—	1.00	1.00	—	—	
						30	—	—	1.00	1.00	—	—	
						45	—	—	1.00	1.00	—	—	
60	—	—	1.00	1.00	—	—							
E099	6	100	99	75	77	0	1.00	1.00	0.83	0.55	—	—	
						2	1.00	1.00	1.00	0.76	—	—	
						4	1.00	1.00	1.00	0.85	—	—	
						6	1.00	1.00	1.00	0.88	—	—	
						8	1.00	1.00	1.00	0.91	—	—	
						10	1.00	1.00	1.00	0.92	—	—	
						15	—	—	1.00	0.96	—	—	
						20	—	—	1.00	0.98	—	—	
						30	—	—	1.00	1.00	—	—	
						45	—	—	1.00	1.00	—	—	
60	—	—	1.00	1.00	—	—							
E125	6	125	125	100	99	0	1.00	0.86	0.68	0.43	—	—	
						2	1.00	1.00	0.92	0.60	—	—	
						4	1.00	1.00	1.00	0.67	—	—	
						6	1.00	1.00	1.00	0.69	—	—	
						8	1.00	1.00	1.00	0.72	—	—	
						10	1.00	1.00	1.00	0.74	—	—	
						15	—	—	1.00	0.77	—	—	
						20	—	—	1.00	0.78	—	—	
						30	—	—	1.00	0.80	—	—	
						45	—	—	1.00	0.81	—	—	
60	—	—	1.00	0.82	—	—							

### Low Frequency Derating Curves—600V AC Frames 3...7 (Continued)

Cat. No. 206...	Frame	600V AC Power Rating				Low Frequency Derating For All Enclosure Ratings							
		ND		HD		Output Freq. Hz	PWM Frequency kHz						
		Hp	Cont. Amps	Hp	Cont. Amps		0.666	1.33	2	4	8	12	
E144	6	150	144	125	125	0	0.90	0.72	0.57	0.35	—	—	
						2	1.00	0.96	0.78	0.52	—	—	
						4	1.00	1.00	0.86	0.58	—	—	
						6	1.00	1.00	0.93	0.61	—	—	
						8	1.00	1.00	0.96	0.63	—	—	
						10	1.00	1.00	0.97	0.64	—	—	
						15	—	—	1.00	0.67	—	—	
						20	—	—	1.00	0.68	—	—	
						30	—	—	1.00	0.69	—	—	
						45	—	—	1.00	0.70	—	—	
60	—	—	1.00	0.71	—	—							
E192	7	200	192	150	144	0	0.92	0.72	0.57	0.34	—	—	
						2	1.00	1.00	1.00	0.74	—	—	
						4	1.00	1.00	1.00	0.82	—	—	
						6	1.00	1.00	1.00	0.85	—	—	
						8	1.00	1.00	1.00	0.88	—	—	
						10	1.00	1.00	1.00	0.90	—	—	
						15	—	—	1.00	0.93	—	—	
						20	—	—	1.00	0.94	—	—	
						30	—	—	1.00	0.97	—	—	
						45	—	—	1.00	0.98	—	—	
60	—	—	1.00	1.00	—	—							
E242	7	250	242	200	192	0	0.72	0.55	0.45	0.27	—	—	
						2	1.00	1.00	0.89	0.58	—	—	
						4	1.00	1.00	0.97	0.65	—	—	
						6	1.00	1.00	1.00	0.67	—	—	
						8	1.00	1.00	1.00	0.69	—	—	
						10	1.00	1.00	1.00	0.71	—	—	
						15	—	—	1.00	0.73	—	—	
						20	—	—	1.00	0.74	—	—	
						30	—	—	1.00	0.75	—	—	
						45	—	—	1.00	0.76	—	—	
60	—	—	1.00	0.77	—	—							

### Low Frequency Derating Curves—600V AC Frames 3...7 (Continued)

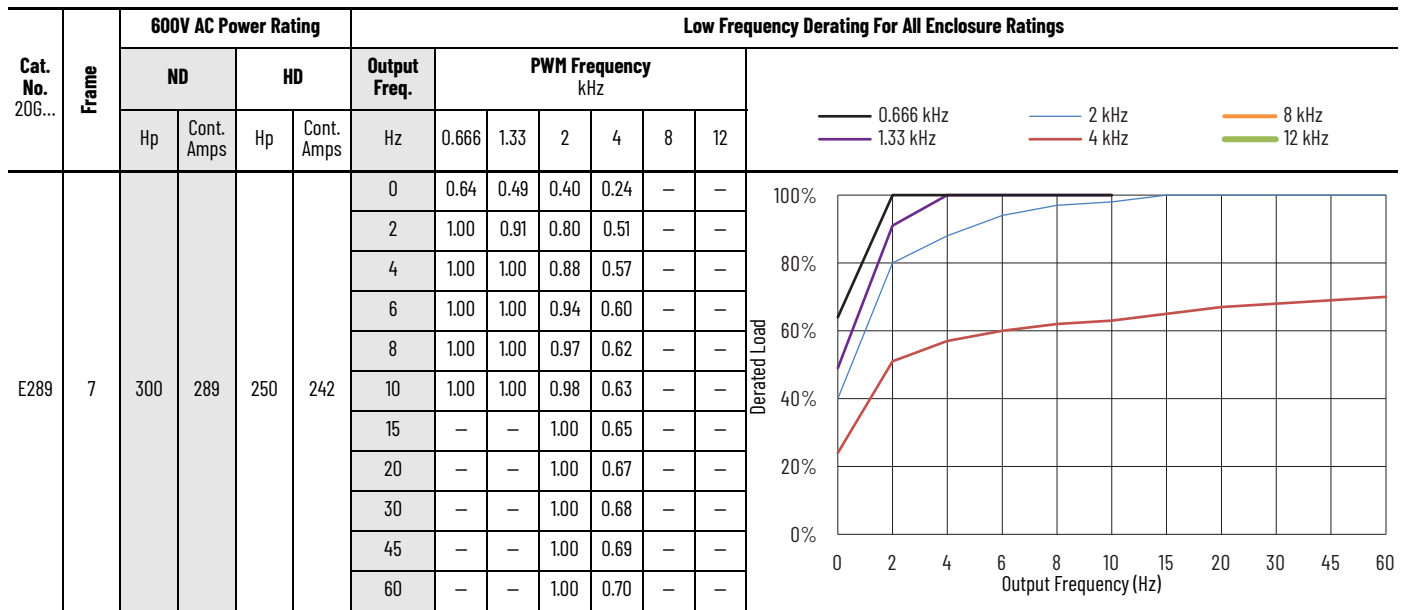

# Low Frequency Derating—690V

The following graphs show the low frequency deratings for 690V PowerFlex 755TS drives specified at the maximum rated ambient temperature at 0 meters altitude.

## Low Frequency Derating Curves—690V AC Frames 6 and 7

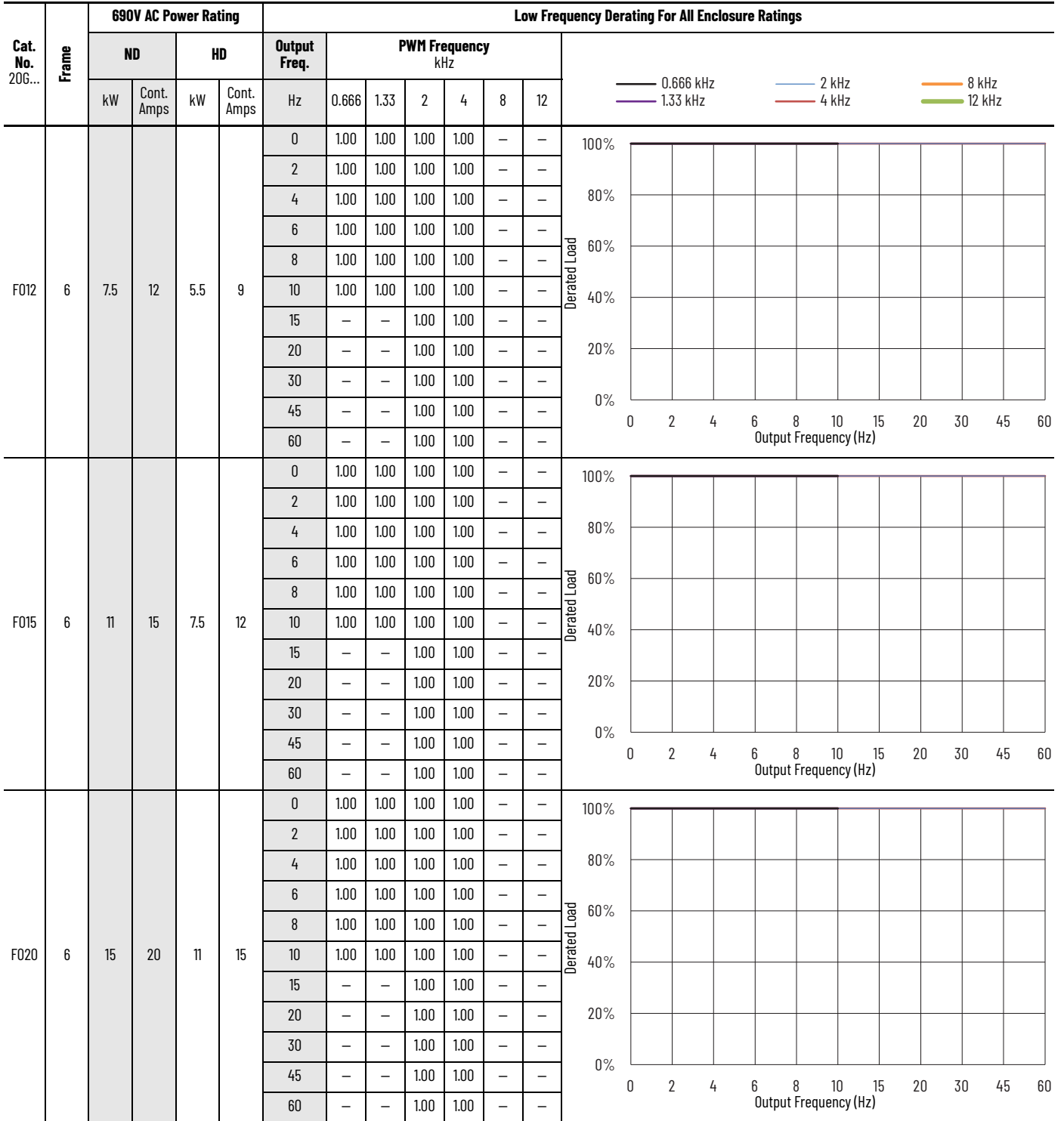

### Low Frequency Derating Curves—690V AC Frames 6 and 7 (Continued)

Cat. No. 20G...	Frame	690V AC Power Rating				Low Frequency Derating For All Enclosure Ratings								
		ND		HD		Output Freq. Hz	PWM Frequency kHz					Derated Load		
		kW	Cont. Amps	kW	Cont. Amps		0.666	1.33	2	4	8			12
F023	6	18.5	23	15	20	0	1.00	1.00	1.00	1.00	—		—	100%
						2	1.00	1.00	1.00	1.00	—	—		
						4	1.00	1.00	1.00	1.00	—	—		
						6	1.00	1.00	1.00	1.00	—	—		
						8	1.00	1.00	1.00	1.00	—	—		
						10	1.00	1.00	1.00	1.00	—	—		
						15	—	—	1.00	1.00	—	—		
						20	—	—	1.00	1.00	—	—		
						30	—	—	1.00	1.00	—	—		
						45	—	—	1.00	1.00	—	—		
60	—	—	1.00	1.00	—	—								
F030	6	22	30	18.5	23	0	1.00	1.00	1.00	0.79	—	—	100%	
						2	1.00	1.00	1.00	1.00	—	—		
						4	1.00	1.00	1.00	1.00	—	—		
						6	1.00	1.00	1.00	1.00	—	—		
						8	1.00	1.00	1.00	1.00	—	—		
						10	1.00	1.00	1.00	1.00	—	—		
						15	—	—	1.00	1.00	—	—		
						20	—	—	1.00	1.00	—	—		
						30	—	—	1.00	1.00	—	—		
						45	—	—	1.00	1.00	—	—		
60	—	—	1.00	1.00	—	—								
F034	6	30	34	22	30	0	1.00	1.00	1.00	0.70	—	—	100%	
						2	1.00	1.00	1.00	1.00	—	—		
						4	1.00	1.00	1.00	1.00	—	—		
						6	1.00	1.00	1.00	1.00	—	—		
						8	1.00	1.00	1.00	1.00	—	—		
						10	1.00	1.00	1.00	1.00	—	—		
						15	—	—	1.00	1.00	—	—		
						20	—	—	1.00	1.00	—	—		
						30	—	—	1.00	1.00	—	—		
						45	—	—	1.00	1.00	—	—		
60	—	—	1.00	1.00	—	—								

**Low Frequency Derating Curves—690V AC Frames 6 and 7 (Continued)**

Cat. No. 20G...	Frame	690V AC Power Rating				Low Frequency Derating For All Enclosure Ratings							
		ND		HD		Output Freq. Hz	PWM Frequency kHz						
		kW	Cont. Amps	kW	Cont. Amps		0.666	1.33	2	4	8		
F046	6	37	46	30	34	0	1.00	1.00	0.89	0.52	—		—
						2	1.00	1.00	1.00	0.99	—	—	
						4	1.00	1.00	1.00	1.00	—	—	
						6	1.00	1.00	1.00	1.00	—	—	
						8	1.00	1.00	1.00	1.00	—	—	
						10	1.00	1.00	1.00	1.00	—	—	
						15	—	—	1.00	1.00	—	—	
						20	—	—	1.00	1.00	—	—	
						30	—	—	1.00	1.00	—	—	
						45	—	—	1.00	1.00	—	—	
60	—	—	1.00	1.00	—	—							
F050	6	45	50	37	46	0	1.00	1.00	0.82	0.48	—	—	
						2	1.00	1.00	1.00	0.91	—	—	
						4	1.00	1.00	1.00	1.00	—	—	
						6	1.00	1.00	1.00	1.00	—	—	
						8	1.00	1.00	1.00	1.00	—	—	
						10	1.00	1.00	1.00	1.00	—	—	
						15	—	—	1.00	1.00	—	—	
						20	—	—	1.00	1.00	—	—	
						30	—	—	1.00	1.00	—	—	
						45	—	—	1.00	1.00	—	—	
60	—	—	1.00	1.00	—	—							
F061	6	55	61	45	50	0	1.00	1.00	1.00	0.80	—	—	
						2	1.00	1.00	1.00	1.00	—	—	
						4	1.00	1.00	1.00	1.00	—	—	
						6	1.00	1.00	1.00	1.00	—	—	
						8	1.00	1.00	1.00	1.00	—	—	
						10	1.00	1.00	1.00	1.00	—	—	
						15	—	—	1.00	1.00	—	—	
						20	—	—	1.00	1.00	—	—	
						30	—	—	1.00	1.00	—	—	
						45	—	—	1.00	1.00	—	—	
60	—	—	1.00	1.00	—	—							

### Low Frequency Derating Curves—690V AC Frames 6 and 7 (Continued)

Cat. No. 20G...	Frame	690V AC Power Rating				Low Frequency Derating For All Enclosure Ratings							
		ND		HD		Output Freq. Hz	PWM Frequency kHz						
		kW	Cont. Amps	kW	Cont. Amps		0.666	1.33	2	4	8	12	
F082	6	75	82	55	61	0	1.00	1.00	0.99	0.60	—	—	
						2	1.00	1.00	1.00	0.83	—	—	
						4	1.00	1.00	1.00	0.93	—	—	
						6	1.00	1.00	1.00	0.99	—	—	
						8	1.00	1.00	1.00	1.00	—	—	
						10	1.00	1.00	1.00	1.00	—	—	
						15	—	—	1.00	1.00	—	—	
						20	—	—	1.00	1.00	—	—	
						30	—	—	1.00	1.00	—	—	
						45	—	—	1.00	1.00	—	—	
						60	—	—	1.00	1.00	—	—	
F098	6	90	98	75	82	0	1.00	1.00	0.83	0.50	—	—	
						2	1.00	1.00	0.94	0.69	—	—	
						4	1.00	1.00	1.00	0.78	—	—	
						6	1.00	1.00	1.00	0.80	—	—	
						8	1.00	1.00	1.00	0.83	—	—	
						10	1.00	1.00	1.00	0.85	—	—	
						15	—	—	1.00	0.89	—	—	
						20	—	—	1.00	0.91	—	—	
						30	—	—	1.00	0.92	—	—	
						45	—	—	1.00	0.94	—	—	
						60	—	—	1.00	0.95	—	—	
F119	6	110	119	90	98	0	1.00	0.84	0.68	0.41	—	—	
						2	1.00	1.00	0.94	0.57	—	—	
						4	1.00	1.00	1.00	0.64	—	—	
						6	1.00	1.00	1.00	0.66	—	—	
						8	1.00	1.00	1.00	0.568	—	—	
						10	1.00	1.00	1.00	0.70	—	—	
						15	—	—	1.00	0.73	—	—	
						20	—	—	1.00	0.75	—	—	
						30	—	—	1.00	0.76	—	—	
						45	—	—	1.00	0.77	—	—	
						60	—	—	1.00	0.78	—	—	

### Low Frequency Derating Curves—690V AC Frames 6 and 7 (Continued)

Cat. No. 20G...	Frame	690V AC Power Rating				Low Frequency Derating For All Enclosure Ratings							
		ND		HD		Output Freq. Hz	PWM Frequency kHz						
		kW	Cont. Amps	kW	Cont. Amps		0.666	1.33	2	4	8		12
F142	7	132	142	110	119	0	0.92	0.71	0.57	0.35	—		—
						2	1.00	0.92	0.78	0.48	—	—	
						4	1.00	1.00	0.86	0.53	—	—	
						6	1.00	1.00	0.93	0.55	—	—	
						8	1.00	1.00	0.96	0.58	—	—	
						10	1.00	1.00	0.97	0.59	—	—	
						15	—	—	1.00	0.61	—	—	
						20	—	—	1.00	0.63	—	—	
						30	—	—	1.00	0.64	—	—	
						45	—	—	1.00	0.65	—	—	
60	—	—	1.00	0.66	—	—							
F171	7	160	171	132	142	0	1.00	0.75	0.57	0.34	—	—	
						2	1.00	1.00	1.00	0.75	—	—	
						4	1.00	1.00	1.00	0.83	—	—	
						6	1.00	1.00	1.00	0.87	—	—	
						8	1.00	1.00	1.00	0.89	—	—	
						10	1.00	1.00	1.00	0.91	—	—	
						15	—	—	1.00	0.95	—	—	
						20	—	—	1.00	0.97	—	—	
						30	—	—	1.00	0.99	—	—	
						45	—	—	1.00	1.00	—	—	
60	—	—	1.00	1.00	—	—							
F212	7	200	212	160	171	0	0.80	0.60	0.45	0.27	—	—	
						2	1.00	1.00	0.94	0.60	—	—	
						4	1.00	1.00	1.00	0.67	—	—	
						6	1.00	1.00	1.00	0.70	—	—	
						8	1.00	1.00	1.00	0.72	—	—	
						10	1.00	1.00	1.00	0.73	—	—	
						15	—	—	1.00	0.76	—	—	
						20	—	—	1.00	0.78	—	—	
						30	—	—	1.00	0.79	—	—	
						45	—	—	1.00	0.80	—	—	
60	—	—	1.00	0.81	—	—							

### Low Frequency Derating Curves—690V AC Frames 6 and 7 (Continued)

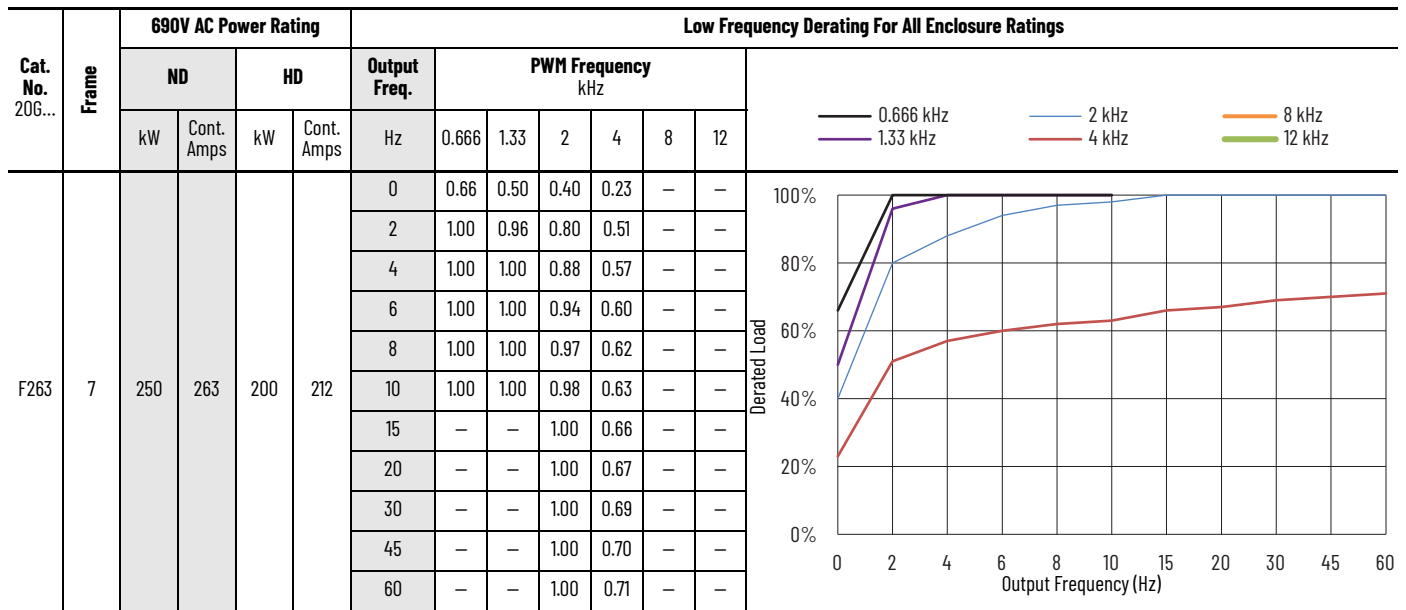

# Ambient Temperature Derating—208V

The following graphs show the ambient temperature deratings for 208V PowerFlex 755TS products specified at the rated 60 Hz output fundamental frequency at 0 meters altitude.

## Ambient Temperature Derating Curves—204V AC Frames 1..7

Cat. No. 206...	Frame	204V AC Power Rating				Ambient Temperature/Load Derating										
		ND		HD		Ambient °C	PWM Frequency kHz				Max Ambient Temperature/Derated Load					
		kW	Cont. Amps	kW	Cont. Amps		2	4	8	12	IP54, Flange, NEMA/UL Type 1 and Type 12   IP20/IP00, NEMA/UL Open Type --- 2 kHz    --- 8 kHz    --- 2 kHz    --- 8 kHz --- 4 kHz    --- 12 kHz    --- 4 kHz    --- 12 kHz					
B2P2	1	0.37	2.5	0.37	2.5	60	0.90	0.90	0.90	0.90						
						50	1.00	1.00	1.00	1.00						
						40	1.00	1.00	1.00	1.00						
						30	1.00	1.00	1.00	1.00						
						20	1.00	1.00	1.00	1.00						
						10	1.00	1.00	1.00	1.00						
						0	1.00	1.00	1.00	1.00						
						-10	1.00	1.00	1.00	1.00						
						-20	1.00	1.00	1.00	1.00						
B4P2	1	0.75	4.8	0.37	2.5	60	0.90	0.90	0.90	0.90						
						50	1.00	1.00	1.00	1.00						
						40	1.00	1.00	1.00	1.00						
						30	1.00	1.00	1.00	1.00						
						20	1.00	1.00	1.00	1.00						
						10	1.00	1.00	1.00	1.00						
						0	1.00	1.00	1.00	1.00						
						-10	1.00	1.00	1.00	1.00						
						-20	1.00	1.00	1.00	1.00						
B6P8	1	1.5	7.8	0.75	4.8	60	0.90	0.90	0.90	0.90						
						50	1.00	1.00	1.00	1.00						
						40	1.00	1.00	1.00	1.00						
						30	1.00	1.00	1.00	1.00						
						20	1.00	1.00	1.00	1.00						
						10	1.00	1.00	1.00	1.00						
						0	1.00	1.00	1.00	1.00						
						-10	1.00	1.00	1.00	1.00						
						-20	1.00	1.00	1.00	1.00						

### Ambient Temperature Derating Curves—204V AC Frames 1..7 (Continued)

Cat. No. 206...	Frame	204V AC Power Rating				Ambient Temperature/Load Derating									
		ND		HD		Ambient °C	PWM Frequency kHz				Max Ambient Temperature/Derated Load				
		kW	Cont. Amps	kW	Cont. Amps		2	4	8	12	IP54, Flange, NEMA/UL Type 1 and Type 12 IP20/IP00, NEMA/UL Open Type				
B9P6	1	2.2	11	1.5	7.8	60	0.90	0.90	0.90	0.90					
						50	1.00	1.00	1.00	1.00					
						40	1.00	1.00	1.00	1.00					
						30	1.00	1.00	1.00	1.00					
						20	1.00	1.00	1.00	1.00					
						10	1.00	1.00	1.00	1.00					
						0	1.00	1.00	1.00	1.00					
						-10	1.00	1.00	1.00	1.00					
						-20	1.00	1.00	1.00	1.00					
B015	1	4	15.3	2.2	11	60	0.90	0.90	0.90	0.78					
						50	1.00	1.00	1.00	0.87					
						40	1.00	1.00	1.00	1.00					
						30	1.00	1.00	1.00	1.00					
						20	1.00	1.00	1.00	1.00					
						10	1.00	1.00	1.00	1.00					
						0	1.00	1.00	1.00	1.00					
						-10	1.00	1.00	1.00	1.00					
						-20	1.00	1.00	1.00	1.00					
B2P2	2	0.37	2.5	0.37	2.5	60	0.90	0.90	0.90	0.90					
						50	1.00	1.00	1.00	1.00					
						40	1.00	1.00	1.00	1.00					
						30	1.00	1.00	1.00	1.00					
						20	1.00	1.00	1.00	1.00					
						10	1.00	1.00	1.00	1.00					
						0	1.00	1.00	1.00	1.00					
						-10	1.00	1.00	1.00	1.00					
						-20	1.00	1.00	1.00	1.00					

### Ambient Temperature Derating Curves—204V AC Frames 1..7 (Continued)

Cat. No. 206...	Frame	204V AC Power Rating				Ambient Temperature/Load Derating									
		ND		HD		Ambient	PWM Frequency kHz				Max Ambient Temperature/Derated Load				
		kW	Cont. Amps	kW	Cont. Amps	°C	2	4	8	12	IP54, Flange, NEMA/UL Type 1 and Type 12 IP20/IP00, NEMA/UL Open Type --- 2 kHz    --- 8 kHz    --- 2 kHz    --- 8 kHz --- 4 kHz    --- 12 kHz    --- 4 kHz    --- 12 kHz				
B4P2	2	0.75	4.8	0.75	4.8	60	0.90	0.90	0.90	0.90					
						50	1.00	1.00	1.00	1.00					
						40	1.00	1.00	1.00	1.00					
						30	1.00	1.00	1.00	1.00					
						20	1.00	1.00	1.00	1.00					
						10	1.00	1.00	1.00	1.00					
						0	1.00	1.00	1.00	1.00					
						-10	1.00	1.00	1.00	1.00					
						-20	1.00	1.00	1.00	1.00					
B6P8	2	1.5	7.8	1.5	7.8	60	0.90	0.90	0.90	0.90					
						50	1.00	1.00	1.00	1.00					
						40	1.00	1.00	1.00	1.00					
						30	1.00	1.00	1.00	1.00					
						20	1.00	1.00	1.00	1.00					
						10	1.00	1.00	1.00	1.00					
						0	1.00	1.00	1.00	1.00					
						-10	1.00	1.00	1.00	1.00					
						-20	1.00	1.00	1.00	1.00					
B9P6	2	2.2	11	2.2	11	60	0.90	0.90	0.90	0.90					
						50	1.00	1.00	1.00	1.00					
						40	1.00	1.00	1.00	1.00					
						30	1.00	1.00	1.00	1.00					
						20	1.00	1.00	1.00	1.00					
						10	1.00	1.00	1.00	1.00					
						0	1.00	1.00	1.00	1.00					
						-10	1.00	1.00	1.00	1.00					
						-20	1.00	1.00	1.00	1.00					

**Ambient Temperature Derating Curves—204V AC Frames 1..7 (Continued)**

Cat. No. 206...	Frame	204V AC Power Rating				Ambient Temperature/Load Derating										
		ND		HD		Ambient	PWM Frequency kHz				Max Ambient Temperature/Derated Load					
		kW	Cont. Amps	kW	Cont. Amps	°C	2	4	8	12	IP54, Flange, NEMA/UL Type 1 and Type 12 IP20/IP00, NEMA/UL Open Type --- 2 kHz    --- 8 kHz    --- 2 kHz    --- 8 kHz --- 4 kHz    --- 12 kHz    --- 4 kHz    --- 12 kHz					
B015	2	4	17.5	2.2	11	60	0.90	0.90	0.90	0.86						
						50	1.00	1.00	1.00	0.95						
						40	1.00	1.00	1.00	1.00						
						30	1.00	1.00	1.00	1.00						
						20	1.00	1.00	1.00	1.00						
						10	1.00	1.00	1.00	1.00						
						0	1.00	1.00	1.00	1.00						
						-10	1.00	1.00	1.00	1.00						
						-20	1.00	1.00	1.00	1.00						
B022	2	5.5	22	4	17.5	60	0.90	0.90	0.66	0.53						
						50	1.00	1.00	0.75	0.60						
						40	1.00	1.00	0.77	0.63						
						30	1.00	1.00	0.82	0.67						
						20	1.00	1.00	0.88	0.72						
						10	1.00	1.00	0.93	0.76						
						0	1.00	1.00	0.98	0.81						
						-10	1.00	1.00	1.00	0.85						
						-20	1.00	1.00	1.00	0.90						
B028	3	7.5	32.2	5.5	22	60	0.90	0.90	0.90	0.88						
						50	1.00	1.00	1.00	0.93						
						40	1.00	1.00	1.00	1.00						
						30	1.00	1.00	1.00	1.00						
						20	1.00	1.00	1.00	1.00						
						10	1.00	1.00	1.00	1.00						
						0	1.00	1.00	1.00	1.00						
						-10	1.00	1.00	1.00	1.00						
						-20	1.00	1.00	1.00	1.00						

**Ambient Temperature Derating Curves—204V AC Frames 1..7 (Continued)**

Cat. No. 206...	Frame	204V AC Power Rating				Ambient Temperature/Load Derating												
		ND		HD		Ambient	PWM Frequency kHz				Max Ambient Temperature/Derated Load							
		kW	Cont. Amps	kW	Cont. Amps	°C	2	4	8	12	IP54, Flange, NEMA/UL Type 1 and Type 12   IP20/IP00, NEMA/UL Open Type --- 2 kHz --- 8 kHz --- 2 kHz --- 8 kHz --- 4 kHz --- 12 kHz --- 4 kHz --- 12 kHz							
B042	3	11	43	7.5	32.2	60	0.90	0.86	0.59	0.45								
						50	1.00	0.96	0.66	0.50								
						40	1.00	1.00	0.71	0.54								
						30	1.00	1.00	0.77	0.58								
						20	1.00	1.00	0.82	0.62								
						10	1.00	1.00	0.88	0.66								
						0	1.00	1.00	0.93	0.70								
						-10	1.00	1.00	0.97	0.74								
						-20	1.00	1.00	1.00	0.78								
B054	4	15	60	11	43	60	0.90	0.83	0.61	0.47								
						50	1.00	0.92	0.68	0.52								
						40	1.00	0.98	0.73	0.56								
						30	1.00	1.00	0.78	0.61								
						20	1.00	1.00	0.84	0.65								
						10	1.00	1.00	0.89	0.70								
						0	1.00	1.00	0.95	0.74								
						-10	1.00	1.00	1.00	0.78								
						-20	1.00	1.00	1.00	0.82								
B055	3	15	61	11	43	60	0.90	0.87	0.72	0.57								
						50	1.00	0.97	0.80	0.63								
						40	1.00	1.00	0.90	0.73								
						30	1.00	1.00	0.97	0.79								
						20	1.00	1.00	1.00	0.84								
						10	1.00	1.00	1.00	0.90								
						0	1.00	1.00	1.00	0.95								
						-10	1.00	1.00	1.00	1.00								
						-20	1.00	1.00	1.00	1.00								

**Ambient Temperature Derating Curves—204V AC Frames 1..7 (Continued)**

Cat. No. 206...	Frame	204V AC Power Rating				Ambient Temperature/Load Derating					
		ND		HD		Ambient	PWM Frequency kHz				Max Ambient Temperature/Derated Load
		kW	Cont. Amps	kW	Cont. Amps	°C	2	4	8	12	
B070	5	18.5	78.2	15	60	60	0.90	0.90	0.70	0.54	
						50	1.00	1.00	0.78	0.60	
						40	1.00	1.00	0.84	0.65	
						30	1.00	1.00	0.90	0.70	
						20	1.00	1.00	0.95	0.75	
						10	1.00	1.00	1.00	0.80	
						0	1.00	1.00	1.00	0.85	
						-10	1.00	1.00	1.00	0.90	
						-20	1.00	1.00	1.00	0.95	
B071	4	18.5	79	15	60	60	0.90	0.78	0.61	0.48	
						50	1.00	0.87	0.68	0.53	
						40	1.00	0.92	0.73	0.58	
						30	1.00	0.98	0.78	0.62	
						20	1.00	1.00	0.84	0.67	
						10	1.00	1.00	0.89	0.71	
						0	1.00	1.00	0.94	0.75	
						-10	1.00	1.00	1.00	0.79	
						-20	1.00	1.00	1.00	0.83	
B080	5	22	92	18.5	78.2	60	0.90	0.74	0.56	0.43	
						50	1.00	0.82	0.62	0.48	
						40	1.00	0.87	0.67	0.52	
						30	1.00	0.93	0.72	0.56	
						20	1.00	0.98	0.77	0.61	
						10	1.00	1.00	0.82	0.65	
						0	1.00	1.00	0.87	0.69	
						-10	1.00	1.00	0.81	0.73	
						-20	1.00	1.00	0.95	0.76	

**Ambient Temperature Derating Curves—204V AC Frames 1..7 (Continued)**

Cat. No. 206...	Frame	204V AC Power Rating				Ambient Temperature/Load Derating												
		ND		HD		Ambient °C	PWM Frequency kHz				Max Ambient Temperature/Derated Load							
		kW	Cont. Amps	kW	Cont. Amps		2	4	8	12	IP54, Flange, NEMA/UL Type 1 and Type 12				IP20/IP00, NEMA/UL Open Type			
B104	6	30	120	22	92	60	0.90	0.90	0.76	0.59								
						50	1.00	1.00	0.84	0.66								
						40	1.00	1.00	0.89	0.71								
						30	1.00	1.00	0.96	0.76								
						20	1.00	1.00	1.00	0.81								
						10	1.00	1.00	1.00	0.86								
						0	1.00	1.00	1.00	0.92								
						-10	1.00	1.00	1.00	0.96								
						-20	1.00	1.00	1.00	1.00								
B130	6	37	150	30	120	60	0.90	0.90	0.76	0.59								
						50	1.00	1.00	0.84	0.66								
						40	1.00	1.00	0.89	0.71								
						30	1.00	1.00	0.96	0.76								
						20	1.00	1.00	1.00	0.81								
						10	1.00	1.00	1.00	0.86								
						0	1.00	1.00	1.00	0.92								
						-10	1.00	1.00	1.00	0.96								
						-20	1.00	1.00	1.00	1.00								
B154	6	45	177	37	150	60	0.90	0.90	0.79	0.61								
						50	1.00	1.00	0.88	0.68								
						40	1.00	1.00	0.95	0.74								
						30	1.00	1.00	1.00	0.80								
						20	1.00	1.00	1.00	0.86								
						10	1.00	1.00	1.00	0.92								
						0	1.00	1.00	1.00	0.97								
						-10	1.00	1.00	1.00	1.00								
						-20	1.00	1.00	1.00	1.00								

**Ambient Temperature Derating Curves—204V AC Frames 1..7 (Continued)**

Cat. No. 206...	Frame	204V AC Power Rating				Ambient Temperature/Load Derating					
		ND		HD		Ambient	PWM Frequency kHz				Max Ambient Temperature/Derated Load
		kW	Cont. Amps	kW	Cont. Amps	°C	2	4	8	12	
B192	6	55	221	45	177	60	0.90	0.86	0.67	0.52	
						50	1.00	0.96	0.74	0.58	
						40	1.00	1.00	0.80	0.63	
						30	1.00	1.00	0.86	0.68	
						20	1.00	1.00	0.92	0.72	
						10	1.00	1.00	0.97	0.77	
						0	1.00	1.00	1.00	0.82	
						-10	1.00	1.00	1.00	0.86	
						-20	1.00	1.00	1.00	0.90	
B260	6	66	260	55	221	60	0.90	0.68	0.49	0.37	
						50	1.00	0.76	0.54	0.41	
						40	1.00	0.82	0.58	0.44	
						30	1.00	0.88	0.62	0.48	
						20	1.00	0.93	0.66	0.51	
						10	1.00	0.98	0.70	0.55	
						0	1.00	1.00	0.75	0.58	
						-10	1.00	1.00	0.79	0.62	
						-20	1.00	1.00	0.83	0.65	
B312	7	90	359	66	260	60	0.90	0.70	0.44	—	
						50	1.00	0.78	0.49	—	
						40	1.00	0.85	0.54	—	
						30	1.00	0.91	0.58	—	
						20	1.00	0.96	0.63	—	
						10	1.00	1.00	0.67	—	
						0	1.00	1.00	0.71	—	
						-10	1.00	1.00	0.75	—	
						-20	1.00	1.00	0.79	—	

### Ambient Temperature Derating Curves—204V AC Frames 1..7 (Continued)

Cat. No. 206...	Frame	204V AC Power Rating				Ambient Temperature/Load Derating									
		ND		HD		Ambient	PWM Frequency kHz				Max Ambient Temperature/Derated Load				
		kW	Cont. Amps	kW	Cont. Amps	°C	2	4	8	12	IP54, Flange, NEMA/UL Type 1 and Type 12   IP20/IP00, NEMA/UL Open Type — 2 kHz — 8 kHz — 2 kHz — 8 kHz - - 4 kHz - - 12 kHz - - 4 kHz - - 12 kHz				
B360	7	110	414	90	359	60	0.90	0.70	0.44	—					
						50	1.00	0.78	0.49	—					
						40	1.00	0.85	0.54	—					
						30	1.00	0.91	0.58	—					
						20	1.00	0.96	0.63	—					
						10	1.00	1.00	0.67	—					
						0	1.00	1.00	0.71	—					
						-10	1.00	1.00	0.75	—					
						-20	1.00	1.00	0.79	—					
B477	7	132	477	90	359	60	0.90	0.70	0.43	—					
						50	1.00	0.78	0.48	—					
						40	1.00	0.85	0.52	—					
						30	1.00	0.91	0.57	—					
						20	1.00	0.98	0.61	—					
						10	1.00	1.00	0.65	—					
						0	1.00	1.00	0.69	—					
						-10	1.00	1.00	0.73	—					
						-20	1.00	1.00	0.77	—					

# Ambient Temperature Derating—240V

The following graphs show the ambient temperature deratings for 240V PowerFlex 755TS products specified at the rated 60 Hz output fundamental frequency at 0 meters altitude.

## Ambient Temperature Derating Curves—240V AC Frames 1..7

Cat. No. 206...	Frame	240V AC Power Rating				Ambient Temperature/Load Derating										
		ND		HD		Ambient	PWM Frequency kHz				Max Ambient Temperature/Derated Load					
		Hp	Cont. Amps	Hp	Cont. Amps	°C	2	4	8	12	IP54, Flange, NEMA/UL Type 1 and Type 12   IP20/IP00, NEMA/UL Open Type --- 2 kHz    --- 8 kHz    --- 2 kHz    --- 8 kHz --- 4 kHz    --- 12 kHz    --- 4 kHz    --- 12 kHz					
B2P2	1	0.5	2.2	0.5	2.2	60	0.90	0.90	0.90	0.90						
						50	1.00	1.00	1.00	1.00						
						40	1.00	1.00	1.00	1.00						
						30	1.00	1.00	1.00	1.00						
						20	1.00	1.00	1.00	1.00						
						10	1.00	1.00	1.00	1.00						
						0	1.00	1.00	1.00	1.00						
						-10	1.00	1.00	1.00	1.00						
						-20	1.00	1.00	1.00	1.00						
B4P2	1	1	4.2	0.5	2.2	60	0.90	0.90	0.90	0.90						
						50	1.00	1.00	1.00	1.00						
						40	1.00	1.00	1.00	1.00						
						30	1.00	1.00	1.00	1.00						
						20	1.00	1.00	1.00	1.00						
						10	1.00	1.00	1.00	1.00						
						0	1.00	1.00	1.00	1.00						
						-10	1.00	1.00	1.00	1.00						
						-20	1.00	1.00	1.00	1.00						
B6P8	1	2	6.8	1	4.2	60	0.90	0.90	0.90	0.90						
						50	1.00	1.00	1.00	1.00						
						40	1.00	1.00	1.00	1.00						
						30	1.00	1.00	1.00	1.00						
						20	1.00	1.00	1.00	1.00						
						10	1.00	1.00	1.00	1.00						
						0	1.00	1.00	1.00	1.00						
						-10	1.00	1.00	1.00	1.00						
						-20	1.00	1.00	1.00	1.00						

### Ambient Temperature Derating Curves—240V AC Frames 1..7 (Continued)

Cat. No. 206...	Frame	240V AC Power Rating				Ambient Temperature/Load Derating										
		ND		HD		Ambient °C	PWM Frequency kHz				Max Ambient Temperature/Derated Load					
		Hp	Cont. Amps	Hp	Cont. Amps		2	4	8	12	IP54, Flange, NEMA/UL Type 1 and Type 12 IP20/IP00, NEMA/UL Open Type					
B9P6	1	3	9.6	2	6.8	60	0.90	0.90	0.90	0.90						
						50	1.00	1.00	1.00	1.00						
						40	1.00	1.00	1.00	1.00						
						30	1.00	1.00	1.00	1.00						
						20	1.00	1.00	1.00	1.00						
						10	1.00	1.00	1.00	1.00						
						0	1.00	1.00	1.00	1.00						
						-10	1.00	1.00	1.00	1.00						
						-20	1.00	1.00	1.00	1.00						
B015	1	5	15	3	9.6	60	0.90	0.90	0.90	0.78						
						50	1.00	1.00	1.00	0.87						
						40	1.00	1.00	1.00	1.00						
						30	1.00	1.00	1.00	1.00						
						20	1.00	1.00	1.00	1.00						
						10	1.00	1.00	1.00	1.00						
						0	1.00	1.00	1.00	1.00						
						-10	1.00	1.00	1.00	1.00						
						-20	1.00	1.00	1.00	1.00						
B2P2	2	0.5	2.2	0.5	2.2	60	0.90	0.90	0.90	0.90						
						50	1.00	1.00	1.00	1.00						
						40	1.00	1.00	1.00	1.00						
						30	1.00	1.00	1.00	1.00						
						20	1.00	1.00	1.00	1.00						
						10	1.00	1.00	1.00	1.00						
						0	1.00	1.00	1.00	1.00						
						-10	1.00	1.00	1.00	1.00						
						-20	1.00	1.00	1.00	1.00						

### Ambient Temperature Derating Curves—240V AC Frames 1..7 (Continued)

Cat. No. 206...	Frame	240V AC Power Rating				Ambient Temperature/Load Derating									
		ND		HD		Ambient	PWM Frequency kHz				Max Ambient Temperature/Derated Load				
		Hp	Cont. Amps	Hp	Cont. Amps	°C	2	4	8	12	IP54, Flange, NEMA/UL Type 1 and Type 12 IP20/IP00, NEMA/UL Open Type				
B4P2	2	1	4.2	1	4.2	60	0.90	0.90	0.90	0.90					
						50	1.00	1.00	1.00	1.00					
						40	1.00	1.00	1.00	1.00					
						30	1.00	1.00	1.00	1.00					
						20	1.00	1.00	1.00	1.00					
						10	1.00	1.00	1.00	1.00					
						0	1.00	1.00	1.00	1.00					
						-10	1.00	1.00	1.00	1.00					
						-20	1.00	1.00	1.00	1.00					
B6P8	2	1.5	6.8	2	6.8	60	0.90	0.90	0.90	0.90					
						50	1.00	1.00	1.00	1.00					
						40	1.00	1.00	1.00	1.00					
						30	1.00	1.00	1.00	1.00					
						20	1.00	1.00	1.00	1.00					
						10	1.00	1.00	1.00	1.00					
						0	1.00	1.00	1.00	1.00					
						-10	1.00	1.00	1.00	1.00					
						-20	1.00	1.00	1.00	1.00					
B9P6	2	3	9.6	3	9.6	60	0.90	0.90	0.90	0.90					
						50	1.00	1.00	1.00	1.00					
						40	1.00	1.00	1.00	1.00					
						30	1.00	1.00	1.00	1.00					
						20	1.00	1.00	1.00	1.00					
						10	1.00	1.00	1.00	1.00					
						0	1.00	1.00	1.00	1.00					
						-10	1.00	1.00	1.00	1.00					
						-20	1.00	1.00	1.00	1.00					

### Ambient Temperature Derating Curves—240V AC Frames 1..7 (Continued)

Cat. No. 206...	Frame	240V AC Power Rating				Ambient Temperature/Load Derating					
		ND		HD		Ambient	PWM Frequency kHz				Max Ambient Temperature/Derated Load
		Hp	Cont. Amps	Hp	Cont. Amps	°C	2	4	8	12	
B015	2	5	15	3	9.6	60	0.90	0.90	0.90	0.86	
						50	1.00	1.00	1.00	0.95	
						40	1.00	1.00	1.00	1.00	
						30	1.00	1.00	1.00	1.00	
						20	1.00	1.00	1.00	1.00	
						10	1.00	1.00	1.00	1.00	
						0	1.00	1.00	1.00	1.00	
						-10	1.00	1.00	1.00	1.00	
						-20	1.00	1.00	1.00	1.00	
B022	2	7.5	22	5	15	60	0.90	0.90	0.66	0.53	
						50	1.00	1.00	0.75	0.60	
						40	1.00	1.00	0.77	0.63	
						30	1.00	1.00	0.82	0.67	
						20	1.00	1.00	0.88	0.72	
						10	1.00	1.00	0.93	0.76	
						0	1.00	1.00	0.98	0.81	
						-10	1.00	1.00	1.00	0.85	
						-20	1.00	1.00	1.00	0.90	
B028	3	10	28	7.5	22	60	0.90	0.90	0.90	0.88	
						50	1.00	1.00	1.00	0.93	
						40	1.00	1.00	1.00	1.00	
						30	1.00	1.00	1.00	1.00	
						20	1.00	1.00	1.00	1.00	
						10	1.00	1.00	1.00	1.00	
						0	1.00	1.00	1.00	1.00	
						-10	1.00	1.00	1.00	1.00	
						-20	1.00	1.00	1.00	1.00	

**Ambient Temperature Derating Curves—240V AC Frames 1..7 (Continued)**

Cat. No. 206...	Frame	240V AC Power Rating				Ambient Temperature/Load Derating									
		ND		HD		Ambient	PWM Frequency kHz				Max Ambient Temperature/Derated Load				
		Hp	Cont. Amps	Hp	Cont. Amps	°C	2	4	8	12	IP54, Flange, NEMA/UL Type 1 and Type 12				
										IP20/IP00, NEMA/UL Open Type					
										— 2 kHz — 8 kHz — 4 kHz — 12 kHz					
B042	3	15	42	10	28	60	0.90	0.86	0.59	0.45					
						50	1.00	0.96	0.66	0.50					
						40	1.00	1.00	0.71	0.54					
						30	1.00	1.00	0.77	0.58					
						20	1.00	1.00	0.82	0.62					
						10	1.00	1.00	0.88	0.66					
						0	1.00	1.00	0.93	0.70					
						-10	1.00	1.00	0.97	0.74					
						-20	1.00	1.00	1.00	0.78					
B054	4	20	55	15	42	60	0.90	0.85	0.61	0.47					
						50	1.00	0.94	0.68	0.52					
						40	1.00	0.98	0.73	0.56					
						30	1.00	1.00	0.78	0.61					
						20	1.00	1.00	0.84	0.65					
						10	1.00	1.00	0.89	0.70					
						0	1.00	1.00	0.95	0.74					
						-10	1.00	1.00	1.00	0.78					
						-20	1.00	1.00	1.00	0.82					
B055	3	20	55	15	42	60	0.90	0.87	0.72	0.57					
						50	1.00	0.97	0.80	0.63					
						40	1.00	1.00	0.90	0.73					
						30	1.00	1.00	0.97	0.79					
						20	1.00	1.00	1.00	0.84					
						10	1.00	1.00	1.00	0.90					
						0	1.00	1.00	1.00	0.95					
						-10	1.00	1.00	1.00	1.00					
						-20	1.00	1.00	1.00	1.00					

### Ambient Temperature Derating Curves—240V AC Frames 1..7 (Continued)

Cat. No. 206...	Frame	240V AC Power Rating				Ambient Temperature/Load Derating					
		ND		HD		Ambient	PWM Frequency kHz				Max Ambient Temperature/Derated Load
		Hp	Cont. Amps	Hp	Cont. Amps	°C	2	4	8	12	
B070	5	25	70	20	54	60	0.90	0.90	0.70	0.54	
						50	1.00	1.00	0.78	0.60	
						40	1.00	1.00	0.84	0.65	
						30	1.00	1.00	0.90	0.70	
						20	1.00	1.00	0.95	0.75	
						10	1.00	1.00	1.00	0.80	
						0	1.00	1.00	1.00	0.85	
						-10	1.00	1.00	1.00	0.90	
						-20	1.00	1.00	1.00	0.95	
B071	4	18.5	79	15	60	60	0.90	0.82	0.61	0.48	
						50	1.00	0.91	0.68	0.53	
						40	1.00	0.97	0.73	0.58	
						30	1.00	1.00	0.78	0.62	
						20	1.00	1.00	0.84	0.67	
						10	1.00	1.00	0.89	0.71	
						0	1.00	1.00	0.94	0.75	
						-10	1.00	1.00	1.00	0.79	
						-20	1.00	1.00	1.00	0.83	
B080	5	30	80	25	70	60	0.90	0.77	0.56	0.43	
						50	1.00	0.85	0.62	0.48	
						40	1.00	0.90	0.67	0.52	
						30	1.00	0.96	0.72	0.56	
						20	1.00	1.00	0.77	0.61	
						10	1.00	1.00	0.82	0.65	
						0	1.00	1.00	0.87	0.69	
						-10	1.00	1.00	0.81	0.73	
						-20	1.00	1.00	0.95	0.76	

**Ambient Temperature Derating Curves—240V AC Frames 1..7 (Continued)**

Cat. No. 206...	Frame	240V AC Power Rating				Ambient Temperature/Load Derating					
		ND		HD		Ambient	PWM Frequency kHz				Max Ambient Temperature/Derated Load
		Hp	Cont. Amps	Hp	Cont. Amps	°C	2	4	8	12	
B104	6	40	104	30	80	60	0.90	0.90	0.76	0.59	
						50	1.00	1.00	0.84	0.66	
						40	1.00	1.00	0.89	0.71	
						30	1.00	1.00	0.96	0.76	
						20	1.00	1.00	1.00	0.81	
						10	1.00	1.00	1.00	0.86	
						0	1.00	1.00	1.00	0.92	
						-10	1.00	1.00	1.00	0.96	
						-20	1.00	1.00	1.00	1.00	
B130	6	50	130	40	104	60	0.90	0.90	0.76	0.59	
						50	1.00	1.00	0.84	0.66	
						40	1.00	1.00	0.89	0.71	
						30	1.00	1.00	0.96	0.76	
						20	1.00	1.00	1.00	0.81	
						10	1.00	1.00	1.00	0.86	
						0	1.00	1.00	1.00	0.92	
						-10	1.00	1.00	1.00	0.96	
						-20	1.00	1.00	1.00	1.00	
B154	6	60	154	50	130	60	0.90	0.90	0.79	0.61	
						50	1.00	1.00	0.88	0.68	
						40	1.00	1.00	0.95	0.74	
						30	1.00	1.00	1.00	0.80	
						20	1.00	1.00	1.00	0.86	
						10	1.00	1.00	1.00	0.92	
						0	1.00	1.00	1.00	0.97	
						-10	1.00	1.00	1.00	1.00	
						-20	1.00	1.00	1.00	1.00	

**Ambient Temperature Derating Curves—240V AC Frames 1..7 (Continued)**

Cat. No. 206...	Frame	240V AC Power Rating				Ambient Temperature/Load Derating					
		ND		HD		Ambient	PWM Frequency kHz				Max Ambient Temperature/Derated Load
		Hp	Cont. Amps	Hp	Cont. Amps	°C	2	4	8	12	
B192	6	75	192	60	154	60	0.90	0.90	0.67	0.52	
						50	1.00	1.00	0.74	0.58	
						40	1.00	1.00	0.80	0.63	
						30	1.00	1.00	0.86	0.68	
						20	1.00	1.00	0.92	0.72	
						10	1.00	1.00	0.97	0.77	
						0	1.00	1.00	1.00	0.82	
						-10	1.00	1.00	1.00	0.86	
						-20	1.00	1.00	1.00	0.90	
B260	6	100	260	75	192	60	0.90	0.68	0.49	0.37	
						50	1.00	0.76	0.54	0.41	
						40	1.00	0.81	0.58	0.44	
						30	1.00	0.87	0.62	0.48	
						20	1.00	0.92	0.66	0.51	
						10	1.00	0.98	0.70	0.55	
						0	1.00	1.00	0.75	0.58	
						-10	1.00	1.00	0.79	0.62	
						-20	1.00	1.00	0.83	0.65	
B312	7	125	312	100	260	60	0.90	0.67	0.44	—	
						50	1.00	0.74	0.49	—	
						40	1.00	0.80	0.54	—	
						30	1.00	0.86	0.58	—	
						20	1.00	0.91	0.63	—	
						10	1.00	0.97	0.67	—	
						0	1.00	1.00	0.71	—	
						-10	1.00	1.00	0.75	—	
						-20	1.00	1.00	0.79	—	

**Ambient Temperature Derating Curves—240V AC Frames 1..7 (Continued)**

Cat. No. 206...	Frame	240V AC Power Rating				Ambient Temperature/Load Derating					
		ND		HD		Ambient	PWM Frequency kHz				Max Ambient Temperature/Derated Load
		Hp	Cont. Amps	Hp	Cont. Amps	°C	2	4	8	12	
<p>IP54, Flange, NEMA/UL Type 1 and Type 12   IP20/IP00, NEMA/UL Open Type</p> <p> <span style="color:blue">—</span> 2 kHz    <span style="color:orange">- - -</span> 8 kHz    <span style="color:blue">—</span> 2 kHz    <span style="color:orange">- - -</span> 8 kHz  <span style="color:red">- - -</span> 4 kHz    <span style="color:green">- - -</span> 12 kHz    <span style="color:red">- - -</span> 4 kHz    <span style="color:green">- - -</span> 12 kHz                 </p>											
B360	7	150	360	125	312	60	0.90	0.67	0.44	—	
						50	1.00	0.74	0.49	—	
						40	1.00	0.80	0.54	—	
						30	1.00	0.86	0.58	—	
						20	1.00	0.91	0.63	—	
						10	1.00	0.97	0.67	—	
						0	1.00	1.00	0.71	—	
						-10	1.00	1.00	0.75	—	
						-20	1.00	1.00	0.79	—	
B477	7	200	477	125	312	60	0.90	0.65	0.43	—	
						50	1.00	0.72	0.48	—	
						40	1.00	0.78	0.52	—	
						30	1.00	0.84	0.57	—	
						20	1.00	0.90	0.61	—	
						10	1.00	0.96	0.65	—	
						0	1.00	1.00	0.69	—	
						-10	1.00	1.00	0.73	—	
						-20	1.00	1.00	0.77	—	

# Ambient Temperature Derating—400V

The following graphs show the ambient temperature deratings for 400V PowerFlex 755TS products specified at the rated 60 Hz output fundamental frequency at 0 meters altitude.

## Ambient Temperature Derating Curves—400V AC Frames 1..7

Cat. No. 206...	Frame	400V AC Power Rating				Ambient Temperature/Load Derating										
		ND		HD		Ambient °C	PWM Frequency kHz				Max Ambient Temperature/Derated Load					
		kW	Cont. Amps	kW	Cont. Amps		2	4	8	12	IP54, Flange, NEMA/UL Type 1 and Type 12   IP20/IP00, NEMA/UL Open Type --- 2 kHz    --- 8 kHz    --- 2 kHz    --- 8 kHz --- 4 kHz    --- 12 kHz    --- 4 kHz    --- 12 kHz					
C2P1	1	0.75	2.1	0.37	1.3	60	0.90	0.90	0.90	0.90						
						50	1.00	1.00	1.00	1.00						
						40	1.00	1.00	1.00	1.00						
						30	1.00	1.00	1.00	1.00						
						20	1.00	1.00	1.00	1.00						
						10	1.00	1.00	1.00	1.00						
						0	1.00	1.00	1.00	1.00						
						-10	1.00	1.00	1.00	1.00						
						-20	1.00	1.00	1.00	1.00						
C3P5	1	1.5	3.5	0.75	3.5	60	0.90	0.90	0.90	0.90						
						50	1.00	1.00	1.00	1.00						
						40	1.00	1.00	1.00	1.00						
						30	1.00	1.00	1.00	1.00						
						20	1.00	1.00	1.00	1.00						
						10	1.00	1.00	1.00	1.00						
						0	1.00	1.00	1.00	1.00						
						-10	1.00	1.00	1.00	1.00						
						-20	1.00	1.00	1.00	1.00						
C5P0	1	2.2	5	1.5	3.5	60	0.90	0.90	0.90	0.90						
						50	1.00	1.00	1.00	1.00						
						40	1.00	1.00	1.00	1.00						
						30	1.00	1.00	1.00	1.00						
						20	1.00	1.00	1.00	1.00						
						10	1.00	1.00	1.00	1.00						
						0	1.00	1.00	1.00	1.00						
						-10	1.00	1.00	1.00	1.00						
						-20	1.00	1.00	1.00	1.00						

### Ambient Temperature Derating Curves—400V AC Frames 1..7 (Continued)

Cat. No. 206...	Frame	400V AC Power Rating				Ambient Temperature/Load Derating									
		ND		HD		Ambient	PWM Frequency kHz				Max Ambient Temperature/Derated Load				
		kW	Cont. Amps	kW	Cont. Amps	°C	2	4	8	12	IP54, Flange, NEMA/UL Type 1 and Type 12 IP20/IP00, NEMA/UL Open Type --- 2 kHz    --- 8 kHz    --- 2 kHz    --- 8 kHz --- 4 kHz    --- 12 kHz    --- 4 kHz    --- 12 kHz				
C8P7	1	4	8.7	2.2	5	60	0.90	0.90	0.90	0.90					
						50	1.00	1.00	1.00	1.00					
						40	1.00	1.00	1.00	1.00					
						30	1.00	1.00	1.00	1.00					
						20	1.00	1.00	1.00	1.00					
						10	1.00	1.00	1.00	1.00					
						0	1.00	1.00	1.00	1.00					
						-10	1.00	1.00	1.00	1.00					
						-20	1.00	1.00	1.00	1.00					
C011	1	5.5	11.5	4	8.7	60	0.90	0.90	0.90	0.90					
						50	1.00	1.00	1.00	1.00					
						40	1.00	1.00	1.00	1.00					
						30	1.00	1.00	1.00	1.00					
						20	1.00	1.00	1.00	1.00					
						10	1.00	1.00	1.00	1.00					
						0	1.00	1.00	1.00	1.00					
						-10	1.00	1.00	1.00	1.00					
						-20	1.00	1.00	1.00	1.00					
C015	1	7.5	15.4	5.5	11.5	60	0.90	0.90	0.90	0.78					
						50	1.00	1.00	1.00	0.87					
						40	1.00	1.00	1.00	1.00					
						30	1.00	1.00	1.00	1.00					
						20	1.00	1.00	1.00	1.00					
						10	1.00	1.00	1.00	1.00					
						0	1.00	1.00	1.00	1.00					
						-10	1.00	1.00	1.00	1.00					
						-20	1.00	1.00	1.00	1.00					

### Ambient Temperature Derating Curves—400V AC Frames 1..7 (Continued)

Cat. No. 206...	Frame	400V AC Power Rating				Ambient Temperature/Load Derating									
		ND		HD		Ambient	PWM Frequency kHz				Max Ambient Temperature/Derated Load				
		kW	Cont. Amps	kW	Cont. Amps	°C	2	4	8	12	IP54, Flange, NEMA/UL Type 1 and Type 12   IP20/IP00, NEMA/UL Open Type --- 2 kHz    --- 8 kHz    --- 2 kHz    --- 8 kHz --- 4 kHz    --- 12 kHz    --- 4 kHz    --- 12 kHz				
C2P1	2	0.75	2.1	0.75	2.1	60	0.90	0.90	0.90	0.90					
						50	1.00	1.00	1.00	1.00					
						40	1.00	1.00	1.00	1.00					
						30	1.00	1.00	1.00	1.00					
						20	1.00	1.00	1.00	1.00					
						10	1.00	1.00	1.00	1.00					
						0	1.00	1.00	1.00	1.00					
						-10	1.00	1.00	1.00	1.00					
						-20	1.00	1.00	1.00	1.00					
C3P5	2	1.5	3.5	1.5	3.5	60	0.90	0.90	0.90	0.90					
						50	1.00	1.00	1.00	1.00					
						40	1.00	1.00	1.00	1.00					
						30	1.00	1.00	1.00	1.00					
						20	1.00	1.00	1.00	1.00					
						10	1.00	1.00	1.00	1.00					
						0	1.00	1.00	1.00	1.00					
						-10	1.00	1.00	1.00	1.00					
						-20	1.00	1.00	1.00	1.00					
C5P0	2	2.2	5	2.2	5	60	0.90	0.90	0.90	0.90					
						50	1.00	1.00	1.00	1.00					
						40	1.00	1.00	1.00	1.00					
						30	1.00	1.00	1.00	1.00					
						20	1.00	1.00	1.00	1.00					
						10	1.00	1.00	1.00	1.00					
						0	1.00	1.00	1.00	1.00					
						-10	1.00	1.00	1.00	1.00					
						-20	1.00	1.00	1.00	1.00					

**Ambient Temperature Derating Curves—400V AC Frames 1..7 (Continued)**

Cat. No. 206...	Frame	400V AC Power Rating				Ambient Temperature/Load Derating									
		ND		HD		Ambient	PWM Frequency kHz				Max Ambient Temperature/Derated Load				
		kW	Cont. Amps	kW	Cont. Amps	°C	2	4	8	12	IP54, Flange, NEMA/UL Type 1 and Type 12   IP20/IP00, NEMA/UL Open Type --- 2 kHz    --- 8 kHz    --- 2 kHz    --- 8 kHz --- 4 kHz    --- 12 kHz    --- 4 kHz    --- 12 kHz				
C8P7	2	4	8.7	4	8.7	60	0.90	0.90	0.90	0.90					
						50	1.00	1.00	1.00	1.00					
						40	1.00	1.00	1.00	1.00					
						30	1.00	1.00	1.00	1.00					
						20	1.00	1.00	1.00	1.00					
						10	1.00	1.00	1.00	1.00					
						0	1.00	1.00	1.00	1.00					
						-10	1.00	1.00	1.00	1.00					
						-20	1.00	1.00	1.00	1.00					
C011	2	5.5	11.5	5.5	11.5	60	0.90	0.90	0.90	0.90					
						50	1.00	1.00	1.00	1.00					
						40	1.00	1.00	1.00	1.00					
						30	1.00	1.00	1.00	1.00					
						20	1.00	1.00	1.00	1.00					
						10	1.00	1.00	1.00	1.00					
						0	1.00	1.00	1.00	1.00					
						-10	1.00	1.00	1.00	1.00					
						-20	1.00	1.00	1.00	1.00					
C015	2	7.5	15.4	5.5	11.5	60	0.90	0.90	0.90	0.86					
						50	1.00	1.00	1.00	0.95					
						40	1.00	1.00	1.00	1.00					
						30	1.00	1.00	1.00	1.00					
						20	1.00	1.00	1.00	1.00					
						10	1.00	1.00	1.00	1.00					
						0	1.00	1.00	1.00	1.00					
						-10	1.00	1.00	1.00	1.00					
						-20	1.00	1.00	1.00	1.00					

**Ambient Temperature Derating Curves—400V AC Frames 1..7 (Continued)**

Cat. No. 206...	Frame	400V AC Power Rating				Ambient Temperature/Load Derating										
		ND		HD		Ambient	PWM Frequency kHz				Max Ambient Temperature/Derated Load					
		kW	Cont. Amps	kW	Cont. Amps	°C	2	4	8	12	IP54, Flange, NEMA/UL Type 1 and Type 12   IP20/IP00, NEMA/UL Open Type --- 2 kHz    --- 8 kHz    --- 2 kHz    --- 8 kHz --- 4 kHz    --- 12 kHz    --- 4 kHz    --- 12 kHz					
C022	2	11	22	7.5	15.4	60	0.90	0.90	0.66	0.53						
						50	1.00	1.00	0.75	0.60						
						40	1.00	1.00	0.77	0.63						
						30	1.00	1.00	0.82	0.67						
						20	1.00	1.00	0.88	0.72						
						10	1.00	1.00	0.93	0.76						
						0	1.00	1.00	0.98	0.81						
						-10	1.00	1.00	1.00	0.85						
						-20	1.00	1.00	1.00	0.90						
C030	3	15	30	11	22	60	0.90	0.90	0.90	0.88						
						50	1.00	1.00	1.00	0.93						
						40	1.00	1.00	1.00	1.00						
						30	1.00	1.00	1.00	1.00						
						20	1.00	1.00	1.00	1.00						
						10	1.00	1.00	1.00	1.00						
						0	1.00	1.00	1.00	1.00						
						-10	1.00	1.00	1.00	1.00						
						-20	1.00	1.00	1.00	1.00						
C037	3	18.5	37	15	30	60	0.90	0.87	0.72	0.67						
						50	1.00	0.97	0.80	0.74						
						40	1.00	1.00	0.85	0.80						
						30	1.00	1.00	0.92	0.85						
						20	1.00	1.00	0.98	0.90						
						10	1.00	1.00	1.00	0.95						
						0	1.00	1.00	1.00	1.00						
						-10	1.00	1.00	1.00	1.00						
						-20	1.00	1.00	1.00	1.00						

**Ambient Temperature Derating Curves—400V AC Frames 1..7 (Continued)**

Cat. No. 206...	Frame	400V AC Power Rating				Ambient Temperature/Load Derating										
		ND		HD		Ambient	PWM Frequency kHz				Max Ambient Temperature/Derated Load					
		kW	Cont. Amps	kW	Cont. Amps	°C	2	4	8	12	IP54, Flange, NEMA/UL Type 1 and Type 12   IP20/IP00, NEMA/UL Open Type --- 2 kHz    --- 8 kHz    --- 2 kHz    --- 8 kHz --- 4 kHz    --- 12 kHz    --- 4 kHz    --- 12 kHz					
C043	3	22	43	18.5	37	60	0.90	0.86	0.59	0.45						
						50	1.00	0.96	0.66	0.50						
						40	1.00	1.00	0.71	0.54						
						30	1.00	1.00	0.77	0.58						
						20	1.00	1.00	0.82	0.62						
						10	1.00	1.00	0.88	0.66						
						0	1.00	1.00	0.93	0.70						
						-10	1.00	1.00	1.00	0.74						
						-20	1.00	1.00	1.00	0.78						
C060	4	30	60	22	43	60	0.90	0.90	0.77	0.59						
						50	1.00	1.00	0.85	0.65						
						40	1.00	1.00	0.91	0.70						
						30	1.00	1.00	0.98	0.75						
						20	1.00	1.00	1.00	0.81						
						10	1.00	1.00	1.00	0.87						
						0	1.00	1.00	1.00	0.92						
						-10	1.00	1.00	1.00	0.96						
						-20	1.00	1.00	1.00	1.00						
C061	3	30	61	22	43	60	0.90	0.87	0.72	0.57						
						50	1.00	0.97	0.80	0.63						
						40	1.00	1.00	0.90	0.73						
						30	1.00	1.00	0.97	0.79						
						20	1.00	1.00	1.00	0.84						
						10	1.00	1.00	1.00	0.90						
						0	1.00	1.00	1.00	0.95						
						-10	1.00	1.00	1.00	1.00						
						-20	1.00	1.00	1.00	1.00						

**Ambient Temperature Derating Curves—400V AC Frames 1..7 (Continued)**

Cat. No. 206...	Frame	400V AC Power Rating				Ambient Temperature/Load Derating										
		ND		HD		Ambient	PWM Frequency kHz				Max Ambient Temperature/Derated Load					
		kW	Cont. Amps	kW	Cont. Amps	°C	2	4	8	12	IP54, Flange, NEMA/UL Type 1 and Type 12   IP20/IP00, NEMA/UL Open Type --- 2 kHz    --- 8 kHz    --- 2 kHz    --- 8 kHz --- 4 kHz    --- 12 kHz    --- 4 kHz    --- 12 kHz					
C072	4	37	72	30	60	60	0.90	0.83	0.61	0.47						
						50	1.00	0.92	0.68	0.52						
						40	1.00	0.98	0.73	0.56						
						30	1.00	1.00	0.78	0.61						
						20	1.00	1.00	0.84	0.65						
						10	1.00	1.00	0.89	0.70						
						0	1.00	1.00	0.95	0.74						
						-10	1.00	1.00	1.00	0.78						
						-20	1.00	1.00	1.00	0.84						
C073	4	37	73	30	60	60	0.90	0.83	0.61	0.47						
						50	1.00	0.92	0.68	0.52						
						40	1.00	0.98	0.73	0.56						
						30	1.00	1.00	0.78	0.61						
						20	1.00	1.00	0.84	0.65						
						10	1.00	1.00	0.89	0.70						
						0	1.00	1.00	0.95	0.74						
						-10	1.00	1.00	1.00	0.78						
						-20	1.00	1.00	1.00	0.84						
C085	5	45	85	37	72	60	0.90	0.90	0.70	0.54						
						50	1.00	1.00	0.78	0.60						
						40	1.00	1.00	0.84	0.65						
						30	1.00	1.00	0.90	0.70						
						20	1.00	1.00	0.95	0.75						
						10	1.00	1.00	0.89	0.80						
						0	1.00	1.00	0.95	0.85						
						-10	1.00	1.00	1.00	0.90						
						-20	1.00	1.00	1.00	0.95						

**Ambient Temperature Derating Curves—400V AC Frames 1..7 (Continued)**

Cat. No. 206...	Frame	400V AC Power Rating				Ambient Temperature/Load Derating										
		ND		HD		Ambient	PWM Frequency kHz				Max Ambient Temperature/Derated Load					
		kW	Cont. Amps	kW	Cont. Amps	°C	2	4	8	12	IP54, Flange, NEMA/UL Type 1 and Type 12   IP20/IP00, NEMA/UL Open Type — 2 kHz — 8 kHz — 2 kHz — 8 kHz - - 4 kHz - - 12 kHz - - 4 kHz - - 12 kHz					
C086	4	45	86	37	72	60	0.90	0.78	0.61	0.48						
						50	1.00	0.87	0.68	0.53						
						40	1.00	0.92	0.73	0.58						
						30	1.00	0.98	0.78	0.62						
						20	1.00	1.00	0.84	0.67						
						10	1.00	1.00	0.89	0.71						
						0	1.00	1.00	0.94	0.75						
						-10	1.00	1.00	1.00	0.79						
						-20	1.00	1.00	1.00	0.83						
C104	5	55	104	45	85	60	0.90	0.74	0.56	0.43						
						50	1.00	0.82	0.62	0.48						
						40	1.00	0.87	0.67	0.52						
						30	1.00	0.93	0.72	0.56						
						20	1.00	0.98	0.77	0.61						
						10	1.00	1.00	0.82	0.65						
						0	1.00	1.00	0.87	0.69						
						-10	1.00	1.00	0.91	0.73						
						-20	1.00	1.00	0.95	0.76						
C140	6	75	140	55	104	60	0.90	0.74	0.56	0.43						
						50	1.00	0.82	0.62	0.48						
						40	1.00	0.87	0.67	0.52						
						30	1.00	0.93	0.72	0.56						
						20	1.00	0.98	0.77	0.61						
						10	1.00	1.00	0.82	0.65						
						0	1.00	1.00	0.87	0.69						
						-10	1.00	1.00	0.91	0.73						
						-20	1.00	1.00	0.95	0.76						

### Ambient Temperature Derating Curves—400V AC Frames 1..7 (Continued)

Cat. No. 206...	Frame	400V AC Power Rating				Ambient Temperature/Load Derating												
		ND		HD		Ambient °C	PWM Frequency kHz				Max Ambient Temperature/Derated Load							
		kW	Cont. Amps	kW	Cont. Amps		2	4	8	12	IP54, Flange, NEMA/UL Type 1 and Type 12				IP20/IP00, NEMA/UL Open Type			
C170	6	75	140	55	104	60	0.90	0.90	0.79	0.61								
						50	1.00	1.00	0.88	0.68								
						40	1.00	1.00	0.95	0.74								
						30	1.00	1.00	1.00	0.80								
						20	1.00	1.00	1.00	0.86								
						10	1.00	1.00	1.00	0.92								
						0	1.00	1.00	1.00	0.97								
						-10	1.00	1.00	1.00	1.00								
						-20	1.00	1.00	1.00	1.00								
C205	6	110	205	90	170	60	0.90	0.90	0.79	0.61								
						50	1.00	1.00	0.88	0.68								
						40	1.00	1.00	0.95	0.74								
						30	1.00	1.00	1.00	0.80								
						20	1.00	1.00	1.00	0.86								
						10	1.00	1.00	1.00	0.92								
						0	1.00	1.00	1.00	0.97								
						-10	1.00	1.00	1.00	1.00								
						-20	1.00	1.00	1.00	1.00								
C260	6	132	260	110	205	60	0.90	0.68	0.49	0.37								
						50	1.00	0.76	0.54	0.41								
						40	1.00	0.82	0.58	0.44								
						30	1.00	0.88	0.62	0.48								
						20	1.00	0.93	0.66	0.51								
						10	1.00	0.98	0.70	0.55								
						0	1.00	1.00	0.75	0.58								
						-10	1.00	1.00	0.79	0.62								
						-20	1.00	1.00	0.83	0.65								

### Ambient Temperature Derating Curves—400V AC Frames 1..7 (Continued)

Cat. No. 206...	Frame	400V AC Power Rating				Ambient Temperature/Load Derating										
		ND		HD		Ambient	PWM Frequency kHz				Max Ambient Temperature/Derated Load					
		kW	Cont. Amps	kW	Cont. Amps	°C	2	4	8	12	IP54, Flange, NEMA/UL Type 1 and Type 12					
C302	7	160	302	132	260	60	0.90	0.86	0.53	—						
						50	1.00	0.95	0.59	—						
						40	1.00	1.00	0.66	—						
						30	1.00	1.00	0.71	—						
						20	1.00	1.00	0.76	—						
						10	1.00	1.00	0.81	—						
						0	1.00	1.00	0.86	—						
						-10	1.00	1.00	0.91	—						
						-20	1.00	1.00	0.95	—						
C367	7	200	367	160	302	60	0.90	0.70	0.44	—						
						50	1.00	0.78	0.49	—						
						40	1.00	0.85	0.54	—						
						30	1.00	0.91	0.58	—						
						20	1.00	0.96	0.63	—						
						10	1.00	1.00	0.67	—						
						0	1.00	1.00	0.71	—						
						-10	1.00	1.00	0.75	—						
						-20	1.00	1.00	0.79	—						
C456	7	250	456	200	367	60	0.90	0.72	0.50	—						
						50	1.00	0.82	0.55	—						
						40	1.00	0.89	0.60	—						
						30	1.00	0.95	0.65	—						
						20	1.00	1.00	0.70	—						
						10	1.00	1.00	0.75	—						
						0	1.00	1.00	0.80	—						
						-10	1.00	1.00	0.85	—						
						-20	1.00	1.00	0.90	—						

### Ambient Temperature Derating Curves—400V AC Frames 1..7 (Continued)

Cat. No. 206...	Frame	400V AC Power Rating				Ambient Temperature/Load Derating									
		ND		HD		Ambient	PWM Frequency kHz				Max Ambient Temperature/Derated Load				
		kW	Cont. Amps	kW	Cont. Amps	°C	2	4	8	12	IP54, Flange, NEMA/UL Type 1 and Type 12   IP20/IP00, NEMA/UL Open Type — 2 kHz — 8 kHz — 2 kHz — 8 kHz - - 4 kHz - - 12 kHz - - 4 kHz - - 12 kHz				
C477	7	270	477	200	367	60	0.90	0.70	0.43	—					
						50	1.00	0.78	0.48	—					
						40	1.00	0.85	0.52	—					
						30	1.00	0.91	0.57	—					
						20	1.00	0.98	0.61	—					
						10	1.00	1.00	0.65	—					
						0	1.00	1.00	0.69	—					
						-10	1.00	1.00	0.73	—					
						-20	1.00	1.00	0.77	—					

# Ambient Temperature Derating—480V

The following graphs show the ambient temperature deratings for 480V PowerFlex 755TS products specified at the rated 60 Hz output fundamental frequency at 0 meters altitude.

## Ambient Temperature Derating Curves—480V AC Frames 1..7

Cat. No. 206...	Frame	480V AC Power Rating				Ambient Temperature/Load Derating										
		ND		HD		Ambient °C	PWM Frequency kHz				Max Ambient Temperature/Derated Load					
		Hp	Cont. Amps	Hp	Cont. Amps		2	4	8	12	IP54, Flange, NEMA/UL Type 1 and Type 12   IP20/IP00, NEMA/UL Open Type --- 2 kHz    --- 8 kHz    --- 2 kHz    --- 8 kHz --- 4 kHz    --- 12 kHz    --- 4 kHz    --- 12 kHz					
D2P1	1	1	2.1	0.5	1.1	60	0.90	0.90	0.90	0.90						
						50	1.00	1.00	1.00	1.00						
						40	1.00	1.00	1.00	1.00						
						30	1.00	1.00	1.00	1.00						
						20	1.00	1.00	1.00	1.00						
						10	1.00	1.00	1.00	1.00						
						0	1.00	1.00	1.00	1.00						
						-10	1.00	1.00	1.00	1.00						
						-20	1.00	1.00	1.00	1.00						
D3P4	1	2	3.4	1	2.1	60	0.90	0.90	0.90	0.90						
						50	1.00	1.00	1.00	1.00						
						40	1.00	1.00	1.00	1.00						
						30	1.00	1.00	1.00	1.00						
						20	1.00	1.00	1.00	1.00						
						10	1.00	1.00	1.00	1.00						
						0	1.00	1.00	1.00	1.00						
						-10	1.00	1.00	1.00	1.00						
						-20	1.00	1.00	1.00	1.00						
D5P0	1	3	5	2	3.4	60	0.90	0.90	0.90	0.90						
						50	1.00	1.00	1.00	1.00						
						40	1.00	1.00	1.00	1.00						
						30	1.00	1.00	1.00	1.00						
						20	1.00	1.00	1.00	1.00						
						10	1.00	1.00	1.00	1.00						
						0	1.00	1.00	1.00	1.00						
						-10	1.00	1.00	1.00	1.00						
						-20	1.00	1.00	1.00	1.00						

**Ambient Temperature Derating Curves—480V AC Frames 1..7 (Continued)**

Cat. No. 206...	Frame	480V AC Power Rating				Ambient Temperature/Load Derating					
		ND		HD		Ambient	PWM Frequency kHz				Max Ambient Temperature/Derated Load
		Hp	Cont. Amps	Hp	Cont. Amps	°C	2	4	8	12	
D8P0	1	4	8.7	2.2	5	60	0.90	0.90	0.90	0.90	<p>IP54, Flange, NEMA/UL Type 1 and Type 12</p> <p>IP20/IP00, NEMA/UL Open Type</p> <p>— 2 kHz — 8 kHz — 2 kHz — 8 kHz</p> <p>- - 4 kHz - - 12 kHz - - 4 kHz - - 12 kHz</p>
						50	1.00	1.00	1.00	1.00	
						40	1.00	1.00	1.00	1.00	
						30	1.00	1.00	1.00	1.00	
						20	1.00	1.00	1.00	1.00	
						10	1.00	1.00	1.00	1.00	
						0	1.00	1.00	1.00	1.00	
						-10	1.00	1.00	1.00	1.00	
						-20	1.00	1.00	1.00	1.00	
D011	1	7.5	11	5	8	60	0.90	0.90	0.90	0.90	
						50	1.00	1.00	1.00	1.00	
						40	1.00	1.00	1.00	1.00	
						30	1.00	1.00	1.00	1.00	
						20	1.00	1.00	1.00	1.00	
						10	1.00	1.00	1.00	1.00	
						0	1.00	1.00	1.00	1.00	
						-10	1.00	1.00	1.00	1.00	
						-20	1.00	1.00	1.00	1.00	
D014	1	10	14	7.5	11	60	0.90	0.90	0.90	0.78	
						50	1.00	1.00	1.00	0.87	
						40	1.00	1.00	1.00	1.00	
						30	1.00	1.00	1.00	1.00	
						20	1.00	1.00	1.00	1.00	
						10	1.00	1.00	1.00	1.00	
						0	1.00	1.00	1.00	1.00	
						-10	1.00	1.00	1.00	1.00	
						-20	1.00	1.00	1.00	1.00	

**Ambient Temperature Derating Curves—480V AC Frames 1..7 (Continued)**

Cat. No. 206...	Frame	480V AC Power Rating				Ambient Temperature/Load Derating										
		ND		HD		Ambient	PWM Frequency kHz				Max Ambient Temperature/Derated Load					
		Hp	Cont. Amps	Hp	Cont. Amps	°C	2	4	8	12	IP54, Flange, NEMA/UL Type 1 and Type 12   IP20/IP00, NEMA/UL Open Type --- 2 kHz    --- 8 kHz    --- 2 kHz    --- 8 kHz --- 4 kHz    --- 12 kHz    --- 4 kHz    --- 12 kHz					
D2P1	2	1	2.1	1	2.1	60	0.90	0.90	0.90	0.90						
						50	1.00	1.00	1.00	1.00						
						40	1.00	1.00	1.00	1.00						
						30	1.00	1.00	1.00	1.00						
						20	1.00	1.00	1.00	1.00						
						10	1.00	1.00	1.00	1.00						
						0	1.00	1.00	1.00	1.00						
						-10	1.00	1.00	1.00	1.00						
						-20	1.00	1.00	1.00	1.00						
D3P4	2	2	3.4	2	3.4	60	0.90	0.90	0.90	0.90						
						50	1.00	1.00	1.00	1.00						
						40	1.00	1.00	1.00	1.00						
						30	1.00	1.00	1.00	1.00						
						20	1.00	1.00	1.00	1.00						
						10	1.00	1.00	1.00	1.00						
						0	1.00	1.00	1.00	1.00						
						-10	1.00	1.00	1.00	1.00						
						-20	1.00	1.00	1.00	1.00						
D5P0	2	3	5	3	5	60	0.90	0.90	0.90	0.90						
						50	1.00	1.00	1.00	1.00						
						40	1.00	1.00	1.00	1.00						
						30	1.00	1.00	1.00	1.00						
						20	1.00	1.00	1.00	1.00						
						10	1.00	1.00	1.00	1.00						
						0	1.00	1.00	1.00	1.00						
						-10	1.00	1.00	1.00	1.00						
						-20	1.00	1.00	1.00	1.00						

**Ambient Temperature Derating Curves—480V AC Frames 1..7 (Continued)**

Cat. No. 206...	Frame	480V AC Power Rating				Ambient Temperature/Load Derating					
		ND		HD		Ambient	PWM Frequency kHz				Max Ambient Temperature/Derated Load
		Hp	Cont. Amps	Hp	Cont. Amps	°C	2	4	8	12	
D8PO	2	5	8	5	8	60	0.90	0.90	0.90	0.90	
						50	1.00	1.00	1.00	1.00	
						40	1.00	1.00	1.00	1.00	
						30	1.00	1.00	1.00	1.00	
						20	1.00	1.00	1.00	1.00	
						10	1.00	1.00	1.00	1.00	
						0	1.00	1.00	1.00	1.00	
						-10	1.00	1.00	1.00	1.00	
						-20	1.00	1.00	1.00	1.00	
D011	2	7.5	11	7.5	11	60	0.90	0.90	0.90	0.90	
						50	1.00	1.00	1.00	1.00	
						40	1.00	1.00	1.00	1.00	
						30	1.00	1.00	1.00	1.00	
						20	1.00	1.00	1.00	1.00	
						10	1.00	1.00	1.00	1.00	
						0	1.00	1.00	1.00	1.00	
						-10	1.00	1.00	1.00	1.00	
						-20	1.00	1.00	1.00	1.00	
D014	2	10	14	7.5	11	60	0.90	0.90	0.90	0.86	
						50	1.00	1.00	1.00	0.95	
						40	1.00	1.00	1.00	1.00	
						30	1.00	1.00	1.00	1.00	
						20	1.00	1.00	1.00	1.00	
						10	1.00	1.00	1.00	1.00	
						0	1.00	1.00	1.00	1.00	
						-10	1.00	1.00	1.00	1.00	
						-20	1.00	1.00	1.00	1.00	

### Ambient Temperature Derating Curves—480V AC Frames 1..7 (Continued)

Cat. No. 206...	Frame	480V AC Power Rating				Ambient Temperature/Load Derating					
		ND		HD		Ambient	PWM Frequency kHz				Max Ambient Temperature/Derated Load
		Hp	Cont. Amps	Hp	Cont. Amps	°C	2	4	8	12	
D022	2	15	22	10	14	60	0.90	0.90	0.66	0.53	
						50	1.00	1.00	0.75	0.60	
						40	1.00	1.00	0.77	0.63	
						30	1.00	1.00	0.82	0.67	
						20	1.00	1.00	0.88	0.72	
						10	1.00	1.00	0.93	0.76	
						0	1.00	1.00	0.98	0.81	
						-10	1.00	1.00	1.00	0.85	
						-20	1.00	1.00	1.00	0.90	
D027	3	20	27	15	22	60	0.90	0.90	0.90	0.88	
						50	1.00	1.00	1.00	0.93	
						40	1.00	1.00	1.00	1.00	
						30	1.00	1.00	1.00	1.00	
						20	1.00	1.00	1.00	1.00	
						10	1.00	1.00	1.00	1.00	
						0	1.00	1.00	1.00	1.00	
						-10	1.00	1.00	1.00	1.00	
						-20	1.00	1.00	1.00	1.00	
D034	3	25	34	20	27	60	0.90	0.90	0.78	0.67	
						50	1.00	1.00	0.87	0.74	
						40	1.00	1.00	0.93	0.80	
						30	1.00	1.00	0.99	0.85	
						20	1.00	1.00	1.00	0.90	
						10	1.00	1.00	1.00	0.95	
						0	1.00	1.00	1.00	1.00	
						-10	1.00	1.00	1.00	1.00	
						-20	1.00	1.00	1.00	1.00	

**Ambient Temperature Derating Curves—480V AC Frames 1..7 (Continued)**

Cat. No. 206...	Frame	480V AC Power Rating				Ambient Temperature/Load Derating										
		ND		HD		Ambient	PWM Frequency kHz				Max Ambient Temperature/Derated Load					
		Hp	Cont. Amps	Hp	Cont. Amps	°C	2	4	8	12	IP54, Flange, NEMA/UL Type 1 and Type 12   IP20/IP00, NEMA/UL Open Type — 2 kHz — 8 kHz — 2 kHz — 8 kHz - - 4 kHz - - 12 kHz - - 4 kHz - - 12 kHz					
D040	3	30	40	25	34	60	0.90	0.86	0.59	0.45						
						50	1.00	0.96	0.66	0.50						
						40	1.00	1.00	0.71	0.54						
						30	1.00	1.00	0.77	0.58						
						20	1.00	1.00	0.82	0.62						
						10	1.00	1.00	0.88	0.66						
						0	1.00	1.00	0.93	0.70						
						-10	1.00	1.00	1.00	0.74						
						-20	1.00	1.00	1.00	0.78						
D052	4	40	52	30	40	60	0.90	0.90	0.77	0.59						
						50	1.00	1.00	0.85	0.65						
						40	1.00	1.00	0.91	0.70						
						30	1.00	1.00	0.98	0.75						
						20	1.00	1.00	1.00	0.81						
						10	1.00	1.00	1.00	0.87						
						0	1.00	1.00	1.00	0.92						
						-10	1.00	1.00	1.00	0.96						
						-20	1.00	1.00	1.00	1.00						
D053	3	40	53	30	40	60	0.90	0.87	0.72	0.57						
						50	1.00	0.97	0.80	0.63						
						40	1.00	1.00	0.90	0.73						
						30	1.00	1.00	0.97	0.79						
						20	1.00	1.00	1.00	0.84						
						10	1.00	1.00	1.00	0.90						
						0	1.00	1.00	1.00	0.95						
						-10	1.00	1.00	1.00	1.00						
						-20	1.00	1.00	1.00	1.00						

### Ambient Temperature Derating Curves—480V AC Frames 1..7 (Continued)

Cat. No. 206...	Frame	480V AC Power Rating				Ambient Temperature/Load Derating										
		ND		HD		Ambient	PWM Frequency kHz				Max Ambient Temperature/Derated Load					
		Hp	Cont. Amps	Hp	Cont. Amps	°C	2	4	8	12	IP54, Flange, NEMA/UL Type 1 and Type 12					
										IP20/IP00, NEMA/UL Open Type						
										— 2 kHz — 8 kHz — 4 kHz — 12 kHz						
D065	4	50	65	40	52	60	0.90	0.85	0.61	0.47						
						50	1.00	0.94	0.68	0.52						
						40	1.00	1.00	0.73	0.56						
						30	1.00	1.00	0.78	0.61						
						20	1.00	1.00	0.84	0.65						
						10	1.00	1.00	0.89	0.70						
						0	1.00	1.00	0.95	0.74						
						-10	1.00	1.00	1.00	0.78						
						-20	1.00	1.00	1.00	0.82						
D066	4	50	66	40	52	60	0.90	0.90	0.72	0.56						
						50	1.00	1.00	0.80	0.62						
						40	1.00	1.00	0.86	0.68						
						30	1.00	1.00	0.93	0.74						
						20	1.00	1.00	1.00	0.79						
						10	1.00	1.00	1.00	0.84						
						0	1.00	1.00	1.00	0.89						
						-10	1.00	1.00	1.00	0.94						
						-20	1.00	1.00	1.00	0.98						
D077	5	60	77	50	65	60	0.90	0.90	0.70	0.54						
						50	1.00	1.00	0.78	0.60						
						40	1.00	1.00	0.84	0.65						
						30	1.00	1.00	0.90	0.70						
						20	1.00	1.00	0.95	0.75						
						10	1.00	1.00	0.89	0.80						
						0	1.00	1.00	0.95	0.85						
						-10	1.00	1.00	1.00	0.90						
						-20	1.00	1.00	1.00	0.95						

**Ambient Temperature Derating Curves—480V AC Frames 1..7 (Continued)**

Cat. No. 206...	Frame	480V AC Power Rating				Ambient Temperature/Load Derating										
		ND		HD		Ambient	PWM Frequency kHz				Max Ambient Temperature/Derated Load					
		Hp	Cont. Amps	Hp	Cont. Amps	°C	2	4	8	12	IP54, Flange, NEMA/UL Type 1 and Type 12 IP20/IP00, NEMA/UL Open Type — 2 kHz — 8 kHz — 2 kHz — 8 kHz - - 4 kHz - - 12 kHz - - 4 kHz - - 12 kHz					
D078	4	60	78	50	65	60	0.90	0.82	0.61	0.48						
						50	1.00	0.91	0.68	0.53						
						40	1.00	0.97	0.73	0.58						
						30	1.00	1.00	0.78	0.62						
						20	1.00	1.00	0.84	0.67						
						10	1.00	1.00	0.89	0.71						
						0	1.00	1.00	0.94	0.75						
						-10	1.00	1.00	0.97	0.79						
						-20	1.00	1.00	1.00	0.83						
D096	5	75	96	60	77	60	0.90	0.77	0.56	0.43						
						50	1.00	0.85	0.62	0.48						
						40	1.00	0.90	0.67	0.52						
						30	1.00	0.96	0.72	0.56						
						20	1.00	1.00	0.77	0.61						
						10	1.00	1.00	0.82	0.65						
						0	1.00	1.00	0.87	0.69						
						-10	1.00	1.00	0.91	0.73						
						-20	1.00	1.00	0.95	0.76						
D125	6	100	125	75	96	60	0.90	0.90	0.76	0.59						
						50	1.00	1.00	0.84	0.66						
						40	1.00	1.00	0.89	0.71						
						30	1.00	1.00	0.96	0.76						
						20	1.00	1.00	1.00	0.81						
						10	1.00	1.00	1.00	0.86						
						0	1.00	1.00	1.00	0.92						
						-10	1.00	1.00	1.00	0.96						
						-20	1.00	1.00	1.00	1.00						

### Ambient Temperature Derating Curves—480V AC Frames 1..7 (Continued)

Cat. No. 206...	Frame	480V AC Power Rating				Ambient Temperature/Load Derating					
		ND		HD		Ambient	PWM Frequency kHz				Max Ambient Temperature/Derated Load
		Hp	Cont. Amps	Hp	Cont. Amps	°C	2	4	8	12	
D156	6	125	156	100	125	60	0.90	0.90	0.79	0.61	
						50	1.00	1.00	0.88	0.68	
						40	1.00	1.00	0.95	0.74	
						30	1.00	1.00	1.00	0.80	
						20	1.00	1.00	1.00	0.86	
						10	1.00	1.00	1.00	0.92	
						0	1.00	1.00	1.00	0.97	
						-10	1.00	1.00	1.00	1.00	
						-20	1.00	1.00	1.00	1.00	
D186	6	150	186	125	156	60	0.90	0.90	0.67	0.52	
						50	1.00	1.00	0.74	0.58	
						40	1.00	1.00	0.80	0.63	
						30	1.00	1.00	0.86	0.68	
						20	1.00	1.00	0.92	0.72	
						10	1.00	1.00	0.97	0.77	
						0	1.00	1.00	1.00	0.82	
						-10	1.00	1.00	1.00	0.86	
						-20	1.00	1.00	1.00	0.90	
D248	6	200	248	150	186	60	0.90	0.68	0.49	0.37	
						50	1.00	0.76	0.54	0.41	
						40	1.00	0.81	0.58	0.44	
						30	1.00	0.87	0.62	0.48	
						20	1.00	0.92	0.66	0.51	
						10	1.00	0.98	0.70	0.55	
						0	1.00	1.00	0.75	0.58	
						-10	1.00	1.00	0.79	0.62	
						-20	1.00	1.00	0.83	0.65	

**Ambient Temperature Derating Curves—480V AC Frames 1..7 (Continued)**

Cat. No. 206...	Frame	480V AC Power Rating				Ambient Temperature/Load Derating										
		ND		HD		Ambient	PWM Frequency kHz				Max Ambient Temperature/Derated Load					
		Hp	Cont. Amps	Hp	Cont. Amps	°C	2	4	8	12	IP54, Flange, NEMA/UL Type 1 and Type 12 IP20/IP00, NEMA/UL Open Type --- 2 kHz    --- 8 kHz    --- 2 kHz    --- 8 kHz --- 4 kHz    --- 12 kHz    --- 4 kHz    --- 12 kHz					
D302	7	250	302	200	248	60	0.90	0.80	0.53	—						
						50	1.00	0.89	0.59	—						
						40	1.00	0.96	0.66	—						
						30	1.00	1.00	0.71	—						
						20	1.00	1.00	0.76	—						
						10	1.00	1.00	0.81	—						
						0	1.00	1.00	0.86	—						
						-10	1.00	1.00	0.91	—						
						-20	1.00	1.00	0.95	—						
D361	7	300	361	250	302	60	0.90	0.67	0.44	—						
						50	1.00	0.74	0.49	—						
						40	1.00	0.80	0.54	—						
						30	1.00	0.86	0.58	—						
						20	1.00	0.91	0.63	—						
						10	1.00	0.97	0.67	—						
						0	1.00	1.00	0.71	—						
						-10	1.00	1.00	0.75	—						
						-20	1.00	1.00	0.79	—						
D415	7	350	415	300	361	60	0.90	0.72	0.50	—						
						50	1.00	0.83	0.55	—						
						40	1.00	0.90	0.60	—						
						30	1.00	0.98	0.65	—						
						20	1.00	1.00	0.70	—						
						10	1.00	1.00	0.75	—						
						0	1.00	1.00	0.80	—						
						-10	1.00	1.00	0.85	—						
						-20	1.00	1.00	0.90	—						

### Ambient Temperature Derating Curves—480V AC Frames 1..7 (Continued)

Cat. No. 206...	Frame	480V AC Power Rating				Ambient Temperature/Load Derating					
		ND		HD		Ambient	PWM Frequency kHz				Max Ambient Temperature/Derated Load
		Hp	Cont. Amps	Hp	Cont. Amps	°C	2	4	8	12	
						IP54, Flange, NEMA/UL Type 1 and Type 12 IP20/IP00, NEMA/UL Open Type					
						— 2 kHz    — 8 kHz    — 2 kHz    — 8 kHz - - 4 kHz    - - 12 kHz    - - 4 kHz    - - 12 kHz					
D477	7	400	477	300	361	60	0.90	0.65	0.43	—	
						50	1.00	0.72	0.48	—	
						40	1.00	0.78	0.52	—	
						30	1.00	0.84	0.57	—	
						20	1.00	0.90	0.61	—	
						10	1.00	0.96	0.65	—	
						0	1.00	1.00	0.69	—	
						-10	1.00	1.00	0.73	—	
						-20	1.00	1.00	0.77	—	

# Ambient Temperature Derating—600V

The following graphs show the ambient temperature deratings for 600V PowerFlex 755TS products specified at the rated 60 Hz output fundamental frequency at 0 meters altitude.

## Ambient Temperature Derating Curves—600V AC Frames 3...7

Cat. No. 206...	Frame	600V AC Power Rating				Ambient Temperature/Load Derating										
		ND		HD		Ambient	PWM Frequency kHz				Max Ambient Temperature/Derated Load					
		Hp	Cont. Amps	Hp	Cont. Amps	°C	2	4	8	12	IP54, Flange, NEMA/UL Type 1 and Type 12 IP20/IP00, NEMA/UL Open Type --- 2 kHz    --- 8 kHz    --- 2 kHz    --- 8 kHz --- 4 kHz    --- 12 kHz    --- 4 kHz    --- 12 kHz					
E1P7	3	1	1.7	0.5	0.9	60	0.90	0.90	0.90	—						
						50	1.00	1.00	1.00	—						
						40	1.00	1.00	1.00	—						
						30	1.00	1.00	1.00	—						
						20	1.00	1.00	1.00	—						
						10	1.00	1.00	1.00	—						
						0	1.00	1.00	1.00	—						
						-10	1.00	1.00	1.00	—						
						-20	1.00	1.00	1.00	—						
E2P7	3	2	2.7	1	1.7	60	0.90	0.90	0.90	—						
						50	1.00	1.00	1.00	—						
						40	1.00	1.00	1.00	—						
						30	1.00	1.00	1.00	—						
						20	1.00	1.00	1.00	—						
						10	1.00	1.00	1.00	—						
						0	1.00	1.00	1.00	—						
						-10	1.00	1.00	1.00	—						
						-20	1.00	1.00	1.00	—						
E3P9	3	3	3.9	2	2.7	60	0.90	0.90	0.90	—						
						50	1.00	1.00	1.00	—						
						40	1.00	1.00	1.00	—						
						30	1.00	1.00	1.00	—						
						20	1.00	1.00	1.00	—						
						10	1.00	1.00	1.00	—						
						0	1.00	1.00	1.00	—						
						-10	1.00	1.00	1.00	—						
						-20	1.00	1.00	1.00	—						

### Ambient Temperature Derating Curves—600V AC Frames 3...7 (Continued)

Cat. No. 206...	Frame	600V AC Power Rating				Ambient Temperature/Load Derating									
		ND		HD		Ambient	PWM Frequency kHz				Max Ambient Temperature/Derated Load				
		Hp	Cont. Amps	Hp	Cont. Amps	°C	2	4	8	12	IP54, Flange, NEMA/UL Type 1 and Type 12   IP20/IP00, NEMA/UL Open Type --- 2 kHz    --- 8 kHz    --- 2 kHz    --- 8 kHz --- 4 kHz    --- 12 kHz    --- 4 kHz    --- 12 kHz				
E6P1	3	5	6.1	3	3.9	60	0.90	0.90	0.90	—					
						50	1.00	1.00	1.00	—					
						40	1.00	1.00	1.00	—					
						30	1.00	1.00	1.00	—					
						20	1.00	1.00	1.00	—					
						10	1.00	1.00	1.00	—					
						0	1.00	1.00	1.00	—					
						-10	1.00	1.00	1.00	—					
						-20	1.00	1.00	1.00	—					
E9P0	3	7.5	9	5	6.1	60	0.90	0.90	0.90	—					
						50	1.00	1.00	1.00	—					
						40	1.00	1.00	1.00	—					
						30	1.00	1.00	1.00	—					
						20	1.00	1.00	1.00	—					
						10	1.00	1.00	1.00	—					
						0	1.00	1.00	1.00	—					
						-10	1.00	1.00	1.00	—					
						-20	1.00	1.00	1.00	—					
E011	3	10	11	7.5	9	60	0.90	0.90	0.90	—					
						50	1.00	1.00	1.00	—					
						40	1.00	1.00	1.00	—					
						30	1.00	1.00	1.00	—					
						20	1.00	1.00	1.00	—					
						10	1.00	1.00	1.00	—					
						0	1.00	1.00	1.00	—					
						-10	1.00	1.00	1.00	—					
						-20	1.00	1.00	1.00	—					

### Ambient Temperature Derating Curves—600V AC Frames 3...7 (Continued)

Cat. No. 206...	Frame	600V AC Power Rating				Ambient Temperature/Load Derating									
		ND		HD		Ambient	PWM Frequency kHz				Max Ambient Temperature/Derated Load				
		Hp	Cont. Amps	Hp	Cont. Amps	°C	2	4	8	12	IP54, Flange, NEMA/UL Type 1 and Type 12   IP20/IP00, NEMA/UL Open Type --- 2 kHz    - - - 8 kHz    ——— 2 kHz    - - - 8 kHz - - - 4 kHz    - - - 12 kHz    ——— 4 kHz    - - - 12 kHz				
E012	6	10	12	7.5	9.1	60	0.90	0.90	-	-					
						50	1.00	1.00	-	-					
						40	1.00	1.00	-	-					
						30	1.00	1.00	-	-					
						20	1.00	1.00	-	-					
						10	1.00	1.00	-	-					
						0	1.00	1.00	-	-					
						-10	1.00	1.00	-	-					
						-20	1.00	1.00	-	-					
E017	3	15	17	10	11	60	0.90	0.90	0.81	-					
						50	1.00	1.00	0.89	-					
						40	1.00	1.00	0.97	-					
						30	1.00	1.00	1.00	-					
						20	1.00	1.00	1.00	-					
						10	1.00	1.00	1.00	-					
						0	1.00	1.00	1.00	-					
						-10	1.00	1.00	1.00	-					
						-20	1.00	1.00	1.00	-					
E018	6	15	18	10	12	60	0.90	0.90	-	-					
						50	1.00	1.00	-	-					
						40	1.00	1.00	-	-					
						30	1.00	1.00	-	-					
						20	1.00	1.00	-	-					
						10	1.00	1.00	-	-					
						0	1.00	1.00	-	-					
						-10	1.00	1.00	-	-					
						-20	1.00	1.00	-	-					

### Ambient Temperature Derating Curves—600V AC Frames 3...7 (Continued)

Cat. No. 206...	Frame	600V AC Power Rating				Ambient Temperature/Load Derating									
		ND		HD		Ambient °C	PWM Frequency kHz				Max Ambient Temperature/Derated Load				
		Hp	Cont. Amps	Hp	Cont. Amps		2	4	8	12	IP54, Flange, NEMA/UL Type 1 and Type 12 IP20/IP00, NEMA/UL Open Type — 2 kHz — 8 kHz — 2 kHz — 8 kHz - - 4 kHz - - 12 kHz - - 4 kHz - - 12 kHz				
E022	3	20	22	15	17	60	0.90	0.90	0.63	-					
						50	1.00	1.00	0.70	-					
						40	1.00	1.00	0.76	-					
						30	1.00	1.00	0.82	-					
						20	1.00	1.00	0.88	-					
						10	1.00	1.00	0.94	-					
						0	1.00	1.00	1.00	-					
						-10	1.00	1.00	1.00	-					
						-20	1.00	1.00	1.00	-					
E023	6	20	23	15	18	60	0.90	0.90	-	-					
						50	1.00	1.00	-	-					
						40	1.00	1.00	-	-					
						30	1.00	1.00	-	-					
						20	1.00	1.00	-	-					
						10	1.00	1.00	-	-					
						0	1.00	1.00	-	-					
						-10	1.00	1.00	-	-					
						-20	1.00	1.00	-	-					
E024	6	20	24	20	22	60	0.90	0.90	-	-					
						50	1.00	1.00	-	-					
						40	1.00	1.00	-	-					
						30	1.00	1.00	-	-					
						20	1.00	1.00	-	-					
						10	1.00	1.00	-	-					
						0	1.00	1.00	-	-					
						-10	1.00	1.00	-	-					
						-20	1.00	1.00	-	-					

### Ambient Temperature Derating Curves—600V AC Frames 3...7 (Continued)

Cat. No. 206...	Frame	600V AC Power Rating				Ambient Temperature/Load Derating										
		ND		HD		Ambient	PWM Frequency kHz				Max Ambient Temperature/Derated Load					
		Hp	Cont. Amps	Hp	Cont. Amps	°C	2	4	8	12	IP54, Flange, NEMA/UL Type 1 and Type 12 IP20/IP00, NEMA/UL Open Type — 2 kHz — 8 kHz — 2 kHz — 8 kHz - - 4 kHz - - 12 kHz - - 4 kHz - - 12 kHz					
E027	4	25	27	20	22	60	0.90	0.90	0.58	—						
						50	1.00	1.00	0.65	—						
						40	1.00	1.00	0.70	—						
						30	1.00	1.00	0.76	—						
						20	1.00	1.00	0.82	—						
						10	1.00	1.00	0.88	—						
						0	1.00	1.00	0.94	—						
						-10	1.00	1.00	0.97	—						
						-20	1.00	1.00	1.00	—						
E028	6	25	28	20	23	60	0.90	0.90	—	—						
						50	1.00	1.00	—	—						
						40	1.00	1.00	—	—						
						30	1.00	1.00	—	—						
						20	1.00	1.00	—	—						
						10	1.00	1.00	—	—						
						0	1.00	1.00	—	—						
						-10	1.00	1.00	—	—						
						-20	1.00	1.00	—	—						
E032	4	30	32	25	27	60	0.90	0.84	0.49	—						
						50	1.00	0.92	0.54	—						
						40	1.00	1.00	0.59	—						
						30	1.00	1.00	0.64	—						
						20	1.00	1.00	0.69	—						
						10	1.00	1.00	0.74	—						
						0	1.00	1.00	0.79	—						
						-10	1.00	1.00	0.84	—						
						-20	1.00	1.00	0.89	—						

### Ambient Temperature Derating Curves—600V AC Frames 3...7 (Continued)

Cat. No. 206...	Frame	600V AC Power Rating				Ambient Temperature/Load Derating									
		ND		HD		Ambient °C	PWM Frequency kHz				Max Ambient Temperature/Derated Load				
		Hp	Cont. Amps	Hp	Cont. Amps		2	4	8	12	IP54, Flange, NEMA/UL Type 1 and Type 12 IP20/IP00, NEMA/UL Open Type — 2 kHz    — 8 kHz    — 2 kHz    — 8 kHz - - 4 kHz    - - 12 kHz    - - 4 kHz    - - 12 kHz				
E033	6	30	33	25	28	60	0.90	0.90	-	-					
						50	1.00	1.00	-	-					
						40	1.00	1.00	-	-					
						30	1.00	1.00	-	-					
						20	1.00	1.00	-	-					
						10	1.00	1.00	-	-					
						0	1.00	1.00	-	-					
						-10	1.00	1.00	-	-					
-20	1.00	1.00	-	-											
E041	5	40	41	30	32	60	0.90	0.90	0.58	-					
						50	1.00	1.00	0.64	-					
						40	1.00	1.00	0.70	-					
						30	1.00	1.00	0.76	-					
						20	1.00	1.00	0.82	-					
						10	1.00	1.00	0.87	-					
						0	1.00	1.00	0.93	-					
						-10	1.00	1.00	0.97	-					
-20	1.00	1.00	1.00	-											
E052	5	50	52	40	41	60	0.90	0.75	0.46	-					
						50	1.00	0.83	0.51	-					
						40	1.00	0.89	0.55	-					
						30	1.00	0.95	0.60	-					
						20	1.00	1.00	0.64	-					
						10	1.00	1.00	0.68	-					
						0	1.00	1.00	0.73	-					
						-10	1.00	1.00	0.77	-					
-20	1.00	1.00	0.82	-											

### Ambient Temperature Derating Curves—600V AC Frames 3...7 (Continued)

Cat. No. 206...	Frame	600V AC Power Rating				Ambient Temperature/Load Derating										
		ND		HD		Ambient	PWM Frequency kHz				Max Ambient Temperature/Derated Load					
		Hp	Cont. Amps	Hp	Cont. Amps	°C	2	4	8	12	IP54, Flange, NEMA/UL Type 1 and Type 12   IP20/IP00, NEMA/UL Open Type --- 2 kHz    --- 8 kHz    --- 2 kHz    --- 8 kHz --- 4 kHz    --- 12 kHz    --- 4 kHz    --- 12 kHz					
E042	6	40	42	30	33	60	0.90	0.90	—	—						
						50	1.00	1.00	—	—						
						40	1.00	1.00	—	—						
						30	1.00	1.00	—	—						
						20	1.00	1.00	—	—						
						10	1.00	1.00	—	—						
						0	1.00	1.00	—	—						
						-10	1.00	1.00	—	—						
						-20	1.00	1.00	—	—						
E053	6	50	53	40	42	60	0.90	0.90	—	—						
						50	1.00	1.00	—	—						
						40	1.00	1.00	—	—						
						30	1.00	1.00	—	—						
						20	1.00	1.00	—	—						
						10	1.00	1.00	—	—						
						0	1.00	1.00	—	—						
						-10	1.00	1.00	—	—						
						-20	1.00	1.00	—	—						
E063	6	60	63	50	52	60	0.90	0.90	—	—						
						50	1.00	1.00	—	—						
						40	1.00	1.00	—	—						
						30	1.00	1.00	—	—						
						20	1.00	1.00	—	—						
						10	1.00	1.00	—	—						
						0	1.00	1.00	—	—						
						-10	1.00	1.00	—	—						
						-20	1.00	1.00	—	—						

**Ambient Temperature Derating Curves—600V AC Frames 3...7 (Continued)**

Cat. No. 206...	Frame	600V AC Power Rating				Ambient Temperature/Load Derating										
		ND		HD		Ambient	PWM Frequency kHz				Max Ambient Temperature/Derated Load					
		Hp	Cont. Amps	Hp	Cont. Amps	°C	2	4	8	12	IP54, Flange, NEMA/UL Type 1 and Type 12   IP20/IP00, NEMA/UL Open Type --- 2 kHz    --- 8 kHz    --- 2 kHz    --- 8 kHz --- 4 kHz    --- 12 kHz    --- 4 kHz    --- 12 kHz					
E077	6	75	77	60	63	60	0.90	0.90	—	—						
						50	1.00	1.00	—	—						
						40	1.00	1.00	—	—						
						30	1.00	1.00	—	—						
						20	1.00	1.00	—	—						
						10	1.00	1.00	—	—						
						0	1.00	1.00	—	—						
						-10	1.00	1.00	—	—						
						-20	1.00	1.00	—	—						
E099	6	100	99	75	77	60	0.90	0.90	—	—						
						50	1.00	1.00	—	—						
						40	1.00	1.00	—	—						
						30	1.00	1.00	—	—						
						20	1.00	1.00	—	—						
						10	1.00	1.00	—	—						
						0	1.00	1.00	—	—						
						-10	1.00	1.00	—	—						
						-20	1.00	1.00	—	—						
E125	6	125	125	100	99	60	0.90	0.74	—	—						
						50	1.00	0.82	—	—						
						40	1.00	0.88	—	—						
						30	1.00	0.95	—	—						
						20	1.00	1.00	—	—						
						10	1.00	1.00	—	—						
						0	1.00	1.00	—	—						
						-10	1.00	1.00	—	—						
						-20	1.00	1.00	—	—						

### Ambient Temperature Derating Curves—600V AC Frames 3...7 (Continued)

Cat. No. 206...	Frame	600V AC Power Rating				Ambient Temperature/Load Derating										
		ND		HD		Ambient	PWM Frequency kHz				Max Ambient Temperature/Derated Load					
		Hp	Cont. Amps	Hp	Cont. Amps	°C	2	4	8	12	IP54, Flange, NEMA/UL Type 1 and Type 12   IP20/IP00, NEMA/UL Open Type --- 2 kHz    --- 8 kHz    --- 2 kHz    --- 8 kHz --- 4 kHz    --- 12 kHz    --- 4 kHz    --- 12 kHz					
E144	6	150	144	125	125	60	0.90	0.64	—	—						
						50	1.00	0.71	—	—						
						40	1.00	0.77	—	—						
						30	1.00	0.83	—	—						
						20	1.00	0.89	—	—						
						10	1.00	0.95	—	—						
						0	1.00	1.00	—	—						
						-10	1.00	1.00	—	—						
						-20	1.00	1.00	—	—						
E192	7	200	192	150	144	60	0.90	0.90	—	—						
						50	1.00	1.00	—	—						
						40	1.00	1.00	—	—						
						30	1.00	1.00	—	—						
						20	1.00	1.00	—	—						
						10	1.00	1.00	—	—						
						0	1.00	1.00	—	—						
						-10	1.00	1.00	—	—						
						-20	1.00	1.00	—	—						
E242	7	250	242	200	192	60	0.90	0.71	—	—						
						50	1.00	0.77	—	—						
						40	1.00	0.84	—	—						
						30	1.00	0.90	—	—						
						20	1.00	0.96	—	—						
						10	1.00	1.00	—	—						
						0	1.00	1.00	—	—						
						-10	1.00	1.00	—	—						
						-20	1.00	1.00	—	—						

### Ambient Temperature Derating Curves—600V AC Frames 3...7 (Continued)

Cat. No. 206...	Frame	600V AC Power Rating				Ambient Temperature/Load Derating					
		ND		HD		Ambient	PWM Frequency kHz				Max Ambient Temperature/Derated Load
		Hp	Cont. Amps	Hp	Cont. Amps	°C	2	4	8	12	
						IP54, Flange, NEMA/UL Type 1 and Type 12 IP20/IP00, NEMA/UL Open Type — 2 kHz — 8 kHz — 2 kHz — 8 kHz - - 4 kHz - - 12 kHz - - 4 kHz - - 12 kHz					
E289	7	300	289	250	242	60	0.90	0.64	-	-	
						50	1.00	0.70	-	-	
						40	1.00	0.75	-	-	
						30	1.00	0.80	-	-	
						20	1.00	0.86	-	-	
						10	1.00	0.91	-	-	
						0	1.00	0.96	-	-	
						-10	1.00	1.00	-	-	
						-20	1.00	1.00	-	-	

# Ambient Temperature Derating—690V

The following graphs show the ambient temperature deratings for 690V PowerFlex 755TS products specified at the rated 60 Hz output fundamental frequency at 0 meters altitude.

## Ambient Temperature Derating Curves—690V AC Frames 6 and 7

Cat. No. 206...	Frame	690V AC Power Rating				Ambient Temperature/Load Derating									
		ND		HD		Ambient	PWM Frequency kHz				Max Ambient Temperature/Derated Load				
		kW	Cont. Amps	kW	Cont. Amps	°C	2	4	8	12	IP54, Flange, NEMA/UL Type 1 and Type 12 IP20/IP00, NEMA/UL Open Type --- 2 kHz    --- 4 kHz    --- 8 kHz    --- 12 kHz				
F012	6	7.5	12	5.5	9	60	0.90	0.90	—	—					
						50	1.00	1.00	—	—					
						40	1.00	1.00	—	—					
						30	1.00	1.00	—	—					
						20	1.00	1.00	—	—					
						10	1.00	1.00	—	—					
						0	1.00	1.00	—	—					
						-10	1.00	1.00	—	—					
						-20	1.00	1.00	—	—					
F015	6	11	15	7.5	9	60	0.90	0.90	—	—					
						50	1.00	1.00	—	—					
						40	1.00	1.00	—	—					
						30	1.00	1.00	—	—					
						20	1.00	1.00	—	—					
						10	1.00	1.00	—	—					
						0	1.00	1.00	—	—					
						-10	1.00	1.00	—	—					
						-20	1.00	1.00	—	—					
F020	6	15	20	11	15	60	0.90	0.90	—	—					
						50	1.00	1.00	—	—					
						40	1.00	1.00	—	—					
						30	1.00	1.00	—	—					
						20	1.00	1.00	—	—					
						10	1.00	1.00	—	—					
						0	1.00	1.00	—	—					
						-10	1.00	1.00	—	—					
						-20	1.00	1.00	—	—					

### Ambient Temperature Derating Curves—690V AC Frames 6 and 7 (Continued)

Cat. No. 206...	Frame	690V AC Power Rating				Ambient Temperature/Load Derating									
		ND		HD		Ambient	PWM Frequency kHz				Max Ambient Temperature/Derated Load				
		kW	Cont. Amps	kW	Cont. Amps	°C	2	4	8	12	IP54, Flange, NEMA/UL Type 1 and Type 12   IP20/IP00, NEMA/UL Open Type --- 2 kHz    --- 8 kHz    --- 2 kHz    --- 8 kHz --- 4 kHz    --- 12 kHz    --- 4 kHz    --- 12 kHz				
F023	6	18.5	23	15	20	60	0.90	0.90	—	—					
						50	1.00	1.00	—	—					
						40	1.00	1.00	—	—					
						30	1.00	1.00	—	—					
						20	1.00	1.00	—	—					
						10	1.00	1.00	—	—					
						0	1.00	1.00	—	—					
						-10	1.00	1.00	—	—					
						-20	1.00	1.00	—	—					
F030	6	22	30	18.5	23	60	0.90	0.90	—	—					
						50	1.00	1.00	—	—					
						40	1.00	1.00	—	—					
						30	1.00	1.00	—	—					
						20	1.00	1.00	—	—					
						10	1.00	1.00	—	—					
						0	1.00	1.00	—	—					
						-10	1.00	1.00	—	—					
						-20	1.00	1.00	—	—					
F034	6	30	34	22	30	60	0.90	0.90	—	—					
						50	1.00	1.00	—	—					
						40	1.00	1.00	—	—					
						30	1.00	1.00	—	—					
						20	1.00	1.00	—	—					
						10	1.00	1.00	—	—					
						0	1.00	1.00	—	—					
						-10	1.00	1.00	—	—					
						-20	1.00	1.00	—	—					

### Ambient Temperature Derating Curves—690V AC Frames 6 and 7 (Continued)

Cat. No. 206...	Frame	690V AC Power Rating				Ambient Temperature/Load Derating									
		ND		HD		Ambient	PWM Frequency kHz				Max Ambient Temperature/Derated Load				
		kW	Cont. Amps	kW	Cont. Amps	°C	2	4	8	12	IP54, Flange, NEMA/UL Type 1 and Type 12   IP20/IP00, NEMA/UL Open Type --- 2 kHz    --- 8 kHz    --- 2 kHz    --- 8 kHz --- 4 kHz    --- 12 kHz    --- 4 kHz    --- 12 kHz				
F046	6	37	46	30	34	60	0.90	0.90	—	—					
						50	1.00	1.00	—	—					
						40	1.00	1.00	—	—					
						30	1.00	1.00	—	—					
						20	1.00	1.00	—	—					
						10	1.00	1.00	—	—					
						0	1.00	1.00	—	—					
						-10	1.00	1.00	—	—					
						-20	1.00	1.00	—	—					
F050	6	45	50	37	46	60	0.90	0.90	—	—					
						50	1.00	1.00	—	—					
						40	1.00	1.00	—	—					
						30	1.00	1.00	—	—					
						20	1.00	1.00	—	—					
						10	1.00	1.00	—	—					
						0	1.00	1.00	—	—					
						-10	1.00	1.00	—	—					
						-20	1.00	1.00	—	—					
F061	6	55	61	45	50	60	0.90	0.90	—	—					
						50	1.00	1.00	—	—					
						40	1.00	1.00	—	—					
						30	1.00	1.00	—	—					
						20	1.00	1.00	—	—					
						10	1.00	1.00	—	—					
						0	1.00	1.00	—	—					
						-10	1.00	1.00	—	—					
						-20	1.00	1.00	—	—					

### Ambient Temperature Derating Curves—690V AC Frames 6 and 7 (Continued)

Cat. No. 206...	Frame	690V AC Power Rating				Ambient Temperature/Load Derating					
		ND		HD		Ambient	PWM Frequency kHz				Max Ambient Temperature/Derated Load
		kW	Cont. Amps	kW	Cont. Amps	°C	2	4	8	12	
F082	6	75	82	55	61	60	0.90	0.90	—	—	<p>IP54, Flange, NEMA/UL Type 1 and Type 12</p> <p>IP20/IP00, NEMA/UL Open Type</p> <p>— 2 kHz    — 8 kHz    — 2 kHz    — 8 kHz                      - - 4 kHz    - - 12 kHz    - - 4 kHz    - - 12 kHz</p>
						50	1.00	1.00	—	—	
						40	1.00	1.00	—	—	
						30	1.00	1.00	—	—	
						20	1.00	1.00	—	—	
						10	1.00	1.00	—	—	
						0	1.00	1.00	—	—	
						-10	1.00	1.00	—	—	
						-20	1.00	1.00	—	—	
F098	6	90	98	75	82	60	0.90	0.86	—	—	
						50	1.00	0.95	—	—	
						40	1.00	1.00	—	—	
						30	1.00	1.00	—	—	
						20	1.00	1.00	—	—	
						10	1.00	1.00	—	—	
						0	1.00	1.00	—	—	
						-10	1.00	1.00	—	—	
						-20	1.00	1.00	—	—	
F119	6	110	119	90	98	60	0.90	0.71	—	—	
						50	1.00	0.78	—	—	
						40	1.00	0.85	—	—	
						30	1.00	0.92	—	—	
						20	1.00	0.98	—	—	
						10	1.00	1.00	—	—	
						0	1.00	1.00	—	—	
						-10	1.00	1.00	—	—	
						-20	1.00	1.00	—	—	

### Ambient Temperature Derating Curves—690V AC Frames 6 and 7 (Continued)

Cat. No. 206...	Frame	690V AC Power Rating				Ambient Temperature/Load Derating										
		ND		HD		Ambient	PWM Frequency kHz				Max Ambient Temperature/Derated Load					
		kW	Cont. Amps	kW	Cont. Amps	°C	2	4	8	12	IP54, Flange, NEMA/UL Type 1 and Type 12   IP20/IP00, NEMA/UL Open Type --- 2 kHz    --- 8 kHz    --- 2 kHz    --- 8 kHz --- 4 kHz    --- 12 kHz    --- 4 kHz    --- 12 kHz					
F142	6	132	142	110	119	60	0.90	0.60	—	—						
						50	1.00	0.66	—	—						
						40	1.00	0.71	—	—						
						30	1.00	0.77	—	—						
						20	1.00	0.82	—	—						
						10	1.00	0.88	—	—						
						0	1.00	0.93	—	—						
						-10	1.00	0.97	—	—						
						-20	1.00	1.00	—	—						
F171	7	160	171	132	142	60	0.90	0.90	—	—						
						50	1.00	1.00	—	—						
						40	1.00	1.00	—	—						
						30	1.00	1.00	—	—						
						20	1.00	1.00	—	—						
						10	1.00	1.00	—	—						
						0	1.00	1.00	—	—						
						-10	1.00	1.00	—	—						
						-20	1.00	1.00	—	—						
F212	7	200	212	160	171	60	0.90	0.74	—	—						
						50	1.00	0.81	—	—						
						40	1.00	0.88	—	—						
						30	1.00	0.94	—	—						
						20	1.00	1.00	—	—						
						10	1.00	1.00	—	—						
						0	1.00	1.00	—	—						
						-10	1.00	1.00	—	—						
						-20	1.00	1.00	—	—						

### Ambient Temperature Derating Curves—690V AC Frames 6 and 7 (Continued)

Cat. No. 206...	Frame	690V AC Power Rating				Ambient Temperature/Load Derating									
		ND		HD		Ambient	PWM Frequency kHz				Max Ambient Temperature/Derated Load				
		kW	Cont. Amps	kW	Cont. Amps	°C	2	4	8	12	IP54, Flange, NEMA/UL Type 1 and Type 12 IP20/IP00, NEMA/UL Open Type --- 2 kHz    --- 8 kHz    --- 2 kHz    --- 8 kHz --- 4 kHz    --- 12 kHz    --- 4 kHz    --- 12 kHz				
F263	7	250	263	200	212	60	0.90	0.65	—	—					
					50	1.00	0.71	—	—						
					40	1.00	0.76	—	—						
					30	1.00	0.81	—	—						
					20	1.00	0.87	—	—						
					10	1.00	0.92	—	—						
					0	1.00	0.97	—	—						
					-10	1.00	1.00	—	—						
					-20	1.00	1.00	—	—						

# Altitude Derating—208V

The following graphs show the altitude deratings for 208V PowerFlex 755TS products specified at the rated 60 Hz output fundamental frequency and the maximum rated ambient temperature.

## Altitude Derating Curves—208V AC Frames 1...7

Cat. No. 206...	Frame	208V AC Power Rating				Altitude/Load Derating					
		ND		HD		Altitude m	PWM Frequency kHz				Altitude/Load
		kW	Cont. Amps	kW	Cont. Amps		2	4	8	12	
B2P2	1	0.37	2.5	0.37	2.5	0	1.00	1.00	1.00	1.00	<p>All Enclosures</p>
					500	1.00	1.00	1.00	1.00		
					1000	1.00	1.00	1.00	1.00		
					1500	1.00	1.00	1.00	1.00		
					2000	1.00	1.00	1.00	1.00		
					2500	-	-	-	-		
					3000	-	-	-	-		
					3500	-	-	-	-		
					4000	-	-	-	-		
					4500	-	-	-	-		
					4800	-	-	-	-		
B4P2	1	0.75	4.8	0.37	2.5	0	1.00	1.00	1.00	1.00	
					500	1.00	1.00	1.00	1.00		
					1000	1.00	1.00	1.00	1.00		
					1500	1.00	1.00	1.00	1.00		
					2000	1.00	1.00	1.00	1.00		
					2500	-	-	-	-		
					3000	-	-	-	-		
					3500	-	-	-	-		
					4000	-	-	-	-		
					4500	-	-	-	-		
					4800	-	-	-	-		

**Altitude Derating Curves—208V AC Frames 1...7 (Continued)**

Cat. No. 206...	Frame	208V AC Power Rating				Altitude/Load Derating					
		ND		HD		Altitude m	PWM Frequency kHz				Altitude/Load
		kW	Cont. Amps	kW	Cont. Amps		2	4	8	12	
B6P8	1	1.5	7.8	0.75	4.8	0	1.00	1.00	1.00	1.00	<p>All Enclosures</p>
						500	1.00	1.00	1.00	1.00	
						1000	1.00	1.00	1.00	1.00	
						1500	1.00	1.00	1.00	1.00	
						2000	1.00	1.00	1.00	1.00	
						2500	-	-	-	-	
						3000	-	-	-	-	
						3500	-	-	-	-	
						4000	-	-	-	-	
						4500	-	-	-	-	
4800	-	-	-	-							
B9P6	1	2.2	11	1.5	7.8	0	1.00	1.00	1.00	1.00	
						500	1.00	1.00	1.00	1.00	
						1000	1.00	1.00	1.00	1.00	
						1500	1.00	1.00	1.00	1.00	
						2000	1.00	1.00	1.00	1.00	
						2500	-	-	-	-	
						3000	-	-	-	-	
						3500	-	-	-	-	
						4000	-	-	-	-	
						4500	-	-	-	-	
4800	-	-	-	-							
B015	1	4	15.3	2.2	11	0	1.00	1.00	1.00	0.87	
						500	1.00	0.98	0.98	0.86	
						1000	1.00	0.95	0.94	0.84	
						1500	1.00	0.92	0.92	0.82	
						2000	1.00	0.90	0.90	0.79	
						2500	-	-	-	-	
						3000	-	-	-	-	
						3500	-	-	-	-	
						4000	-	-	-	-	
						4500	-	-	-	-	
4800	-	-	-	-							

### Altitude Derating Curves—208V AC Frames 1...7 (Continued)

Cat. No. 206...	Frame	208V AC Power Rating				Altitude/Load Derating					
		ND		HD		Altitude m	PWM Frequency kHz				Altitude/Load
		kW	Cont. Amps	kW	Cont. Amps		2	4	8	12	
B2P2	2	0.37	2.5	0.37	2.5	0	1.00	1.00	1.00	1.00	<p>All Enclosures</p>
						500	1.00	1.00	1.00	1.00	
						1000	1.00	1.00	1.00	1.00	
						1500	1.00	1.00	1.00	1.00	
						2000	1.00	1.00	1.00	1.00	
						2500	1.00	1.00	1.00	1.00	
						3000	1.00	1.00	1.00	1.00	
						3500	1.00	1.00	1.00	1.00	
						4000	1.00	1.00	1.00	1.00	
						4500	1.00	1.00	1.00	1.00	
						4800	1.00	1.00	1.00	1.00	
B4P2	2	0.75	4.8	0.75	4.8	0	1.00	1.00	1.00	1.00	
						500	1.00	1.00	1.00	1.00	
						1000	1.00	1.00	1.00	1.00	
						1500	1.00	1.00	1.00	1.00	
						2000	1.00	1.00	1.00	1.00	
						2500	1.00	1.00	1.00	1.00	
						3000	1.00	1.00	1.00	1.00	
						3500	1.00	1.00	1.00	1.00	
						4000	1.00	1.00	1.00	1.00	
						4500	1.00	1.00	1.00	1.00	
						4800	1.00	1.00	1.00	1.00	
B6P8	2	1.5	7.8	1.5	7.8	0	1.00	1.00	1.00	1.00	
						500	1.00	1.00	1.00	1.00	
						1000	1.00	1.00	1.00	1.00	
						1500	1.00	1.00	1.00	1.00	
						2000	1.00	1.00	1.00	1.00	
						2500	1.00	1.00	1.00	1.00	
						3000	1.00	1.00	1.00	1.00	
						3500	1.00	1.00	1.00	1.00	
						4000	1.00	1.00	1.00	1.00	
						4500	1.00	1.00	1.00	1.00	
						4800	1.00	1.00	1.00	1.00	

### Altitude Derating Curves—208V AC Frames 1...7 (Continued)

Cat. No. 206...	Frame	208V AC Power Rating				Altitude/Load Derating					
		ND		HD		Altitude m	PWM Frequency kHz				Altitude/Load
		kW	Cont. Amps	kW	Cont. Amps		2	4	8	12	
B9P6	2	2.2	11	2.2	11	0	1.00	1.00	1.00	1.00	<p>All Enclosures</p>
						500	1.00	1.00	1.00	0.99	
						1000	1.00	1.00	1.00	0.97	
						1500	1.00	1.00	1.00	0.95	
						2000	1.00	1.00	1.00	0.94	
						2500	1.00	1.00	1.00	0.91	
						3000	1.00	1.00	1.00	0.88	
						3500	1.00	1.00	1.00	0.86	
						4000	1.00	1.00	1.00	0.84	
						4500	1.00	1.00	1.00	0.82	
						4800	1.00	1.00	0.98	0.80	
B015	2	4	17.5	2.2	11	0	1.00	1.00	1.00	0.95	
						500	1.00	1.00	1.00	0.95	
						1000	1.00	1.00	1.00	0.95	
						1500	1.00	1.00	1.00	0.95	
						2000	1.00	1.00	1.00	0.95	
						2500	1.00	1.00	1.00	0.95	
						3000	1.00	1.00	1.00	0.95	
						3500	1.00	1.00	1.00	0.95	
						4000	1.00	1.00	1.00	0.95	
						4500	1.00	1.00	1.00	0.95	
						4800	1.00	1.00	0.98	0.93	
B022	2	5.5	22	4	17.5	0	1.00	1.00	0.75	0.60	
						500	1.00	1.00	0.73	0.59	
						1000	1.00	1.00	0.72	0.58	
						1500	1.00	1.00	0.71	0.56	
						2000	1.00	1.00	0.69	0.55	
						2500	1.00	1.00	0.66	0.53	
						3000	1.00	1.00	0.63	0.51	
						3500	1.00	0.98	0.62	0.49	
						4000	1.00	0.95	0.60	0.47	
						4500	1.00	0.93	0.58	0.45	
						4800	1.00	0.90	0.56	0.44	

### Altitude Derating Curves—208V AC Frames 1...7 (Continued)

Cat. No. 206...	Frame	208V AC Power Rating				Altitude/Load Derating					
		ND		HD		Altitude m	PWM Frequency kHz				Altitude/Load
		kW	Cont. Amps	kW	Cont. Amps		2	4	8	12	
B028	3	7.5	32.2	5.5	22	0	1.00	1.00	1.00	0.93	
						500	1.00	1.00	1.00	0.92	
						1000	1.00	1.00	1.00	0.91	
						1500	1.00	1.00	1.00	0.89	
						2000	1.00	1.00	1.00	0.88	
						2500	1.00	1.00	1.00	0.86	
						3000	1.00	1.00	1.00	0.84	
						3500	1.00	1.00	1.00	0.82	
						4000	1.00	1.00	1.00	0.80	
						4500	1.00	1.00	1.00	0.78	
4800	1.00	1.00	1.00	0.76							
B042	3	11	43	7.5	32.2	0	1.00	0.96	0.66	0.46	
						500	1.00	0.96	0.64	0.45	
						1000	1.00	0.96	0.63	0.44	
						1500	1.00	0.96	0.62	0.43	
						2000	1.00	0.96	0.60	0.42	
						2500	1.00	0.95	0.58	0.40	
						3000	1.00	0.93	0.56	0.39	
						3500	1.00	0.90	0.54	0.38	
						4000	1.00	0.87	0.52	0.36	
						4500	1.00	0.84	0.49	0.34	
4800	1.00	0.82	0.46	0.33							
B054	4	15	60	11	43	0	1.00	0.92	0.68	0.52	
						500	1.00	0.91	0.67	0.51	
						1000	1.00	0.88	0.65	0.50	
						1500	1.00	0.87	0.64	0.49	
						2000	1.00	0.86	0.63	0.48	
						2500	1.00	0.84	0.60	0.47	
						3000	1.00	0.82	0.58	0.45	
						3500	0.99	0.79	0.56	0.43	
						4000	0.98	0.77	0.55	0.42	
						4500	0.97	0.75	0.53	0.40	
4800	0.96	0.73	0.51	0.39							

### Altitude Derating Curves—208V AC Frames 1...7 (Continued)

Cat. No. 206...	Frame	208V AC Power Rating				Altitude/Load Derating					
		ND		HD		Altitude m	PWM Frequency kHz				Altitude/Load
		kW	Cont. Amps	kW	Cont. Amps		2	4	8	12	
B055	3	15	61	11	43	0	1.00	0.97	0.80	0.63	
						500	1.00	0.95	0.78	0.61	
						1000	1.00	0.92	0.75	0.59	
						1500	1.00	0.89	0.73	0.57	
						2000	1.00	0.87	0.71	0.55	
						2500	1.00	0.83	0.67	0.52	
						3000	1.00	0.80	0.64	0.49	
						3500	1.00	0.76	0.61	0.47	
						4000	1.00	0.73	0.58	0.45	
						4500	1.00	0.70	0.56	0.43	
4800	1.00	0.67	0.53	0.40							
B070	5	18.5	78.2	15	60	0	1.00	1.00	0.78	0.60	
						500	1.00	1.00	0.77	0.59	
						1000	1.00	1.00	0.75	0.57	
						1500	1.00	1.00	0.73	0.55	
						2000	1.00	1.00	0.72	0.54	
						2500	1.00	1.00	0.69	0.53	
						3000	1.00	0.99	0.65	0.50	
						3500	1.00	0.96	0.63	0.48	
						4000	1.00	0.92	0.61	0.46	
						4500	1.00	0.90	0.59	0.44	
4800	1.00	0.88	0.57	0.42							
B071	4	18.5	79	15	60	0	1.00	0.87	0.68	0.53	
						500	1.00	0.86	0.67	0.51	
						1000	1.00	0.84	0.64	0.50	
						1500	1.00	0.83	0.61	0.48	
						2000	1.00	0.82	0.58	0.45	
						2500	1.00	0.83	0.55	0.43	
						3000	1.00	0.79	0.52	0.40	
						3500	0.99	0.77	0.49	0.38	
						4000	0.98	0.75	0.47	0.36	
						4500	0.97	0.73	0.45	0.35	
4800	0.96	0.69	0.41	0.31							

### Altitude Derating Curves—208V AC Frames 1...7 (Continued)

Cat. No. 206...	Frame	208V AC Power Rating				Altitude/Load Derating					
		ND		HD		Altitude m	PWM Frequency kHz				Altitude/Load
		kW	Cont. Amps	kW	Cont. Amps		2	4	8	12	
B080	5	22	92	18.5	78.2	0	1.00	0.82	0.62	0.48	<p>All Enclosures</p>
						500	1.00	0.82	0.61	0.47	
						1000	1.00	0.80	0.59	0.46	
						1500	1.00	0.79	0.58	0.45	
						2000	1.00	0.77	0.57	0.44	
						2500	1.00	0.75	0.54	0.42	
						3000	1.00	0.72	0.52	0.40	
						3500	0.99	0.70	0.50	0.39	
						4000	0.98	0.68	0.49	0.38	
						4500	0.96	0.66	0.47	0.36	
						4800	0.95	0.65	0.45	0.34	
B104	6	30	120	22	92	0	1.00	1.00	0.84	0.66	
						500	1.00	1.00	0.83	0.65	
						1000	1.00	1.00	0.81	0.63	
						1500	1.00	1.00	0.79	0.62	
						2000	1.00	1.00	0.77	0.60	
						2500	1.00	1.00	0.74	0.57	
						3000	1.00	1.00	0.70	0.55	
						3500	1.00	1.00	0.69	0.53	
						4000	1.00	1.00	0.66	0.50	
						4500	1.00	1.00	0.63	0.49	
						4800	1.00	1.00	0.61	0.47	
B130	6	37	150	30	120	0	1.00	1.00	0.84	0.66	
						500	1.00	1.00	0.83	0.65	
						1000	1.00	1.00	0.81	0.63	
						1500	1.00	1.00	0.79	0.62	
						2000	1.00	1.00	0.77	0.60	
						2500	1.00	1.00	0.74	0.57	
						3000	1.00	1.00	0.70	0.55	
						3500	1.00	1.00	0.69	0.53	
						4000	1.00	1.00	0.66	0.50	
						4500	1.00	1.00	0.63	0.49	
						4800	1.00	1.00	0.61	0.47	

**Altitude Derating Curves—208V AC Frames 1...7 (Continued)**

Cat. No. 206...	Frame	208V AC Power Rating				Altitude/Load Derating					
		ND		HD		Altitude m	PWM Frequency kHz				Altitude/Load
		kW	Cont. Amps	kW	Cont. Amps		2	4	8	12	
B154	6	45	177	37	150	0	1.00	1.00	0.88	0.68	<p>All Enclosures</p>
						500	1.00	1.00	0.87	0.67	
						1000	1.00	1.00	0.84	0.65	
						1500	1.00	1.00	0.83	0.64	
						2000	1.00	1.00	0.80	0.62	
						2500	1.00	1.00	0.77	0.60	
						3000	1.00	1.00	0.74	0.57	
						3500	1.00	1.00	0.71	0.55	
						4000	1.00	1.00	0.69	0.53	
						4500	1.00	1.00	0.67	0.51	
4800	1.00	1.00	0.65	0.49							
B192	6	55	221	45	177	0	1.00	0.96	0.74	0.58	
						500	1.00	0.96	0.72	0.57	
						1000	1.00	0.96	0.70	0.55	
						1500	1.00	0.96	0.69	0.54	
						2000	1.00	0.96	0.67	0.53	
						2500	1.00	0.95	0.64	0.51	
						3000	1.00	0.92	0.62	0.48	
						3500	1.00	0.90	0.60	0.46	
						4000	1.00	0.87	0.57	0.44	
						4500	1.00	0.84	0.56	0.44	
4800	1.00	0.83	0.54	0.43							
B260	6	66	260	55	221	0	1.00	0.76	0.54	0.41	
						500	1.00	0.75	0.53	0.40	
						1000	0.98	0.73	0.52	0.39	
						1500	0.95	0.70	0.50	0.37	
						2000	0.93	0.69	0.49	0.36	
						2500	0.89	0.65	0.47	0.35	
						3000	0.85	0.63	0.44	0.33	
						3500	0.83	0.60	0.42	0.31	
						4000	0.79	0.58	0.40	0.29	
						4500	0.76	0.55	0.39	0.28	
4800	0.74	0.54	0.38	0.27							

### Altitude Derating Curves—208V AC Frames 1...7 (Continued)

Cat. No. 206...	Frame	208V AC Power Rating				Altitude/Load Derating					
		ND		HD		Altitude m	PWM Frequency kHz				Altitude/Load
		kW	Cont. Amps	kW	Cont. Amps		2	4	8	12	
B312	7	90	359	66	260	0	1.00	0.78	0.49	—	<p>All Enclosures</p>
						500	1.00	0.73	0.48	—	
						1000	1.00	0.72	0.47	—	
						1500	0.96	0.69	0.45	—	
						2000	0.94	0.67	0.43	—	
						2500	0.90	0.63	0.41	—	
						3000	0.86	0.61	0.39	—	
						3500	0.83	0.59	0.37	—	
						4000	0.80	0.55	0.35	—	
						4500	0.77	0.53	0.34	—	
						4800	0.75	0.52	0.33	—	
B360	7	110	414	90	359	0	1.00	0.78	0.49	—	
						500	1.00	0.73	0.48	—	
						1000	1.00	0.72	0.47	—	
						1500	0.96	0.69	0.45	—	
						2000	0.94	0.67	0.43	—	
						2500	0.90	0.63	0.41	—	
						3000	0.86	0.61	0.39	—	
						3500	0.83	0.59	0.37	—	
						4000	0.80	0.55	0.35	—	
						4500	0.77	0.53	0.34	—	
						4800	0.75	0.52	0.33	—	
B477	7	132	477	90	359	0	1.00	0.78	0.48	—	
						500	0.97	0.75	0.47	—	
						1000	0.94	0.72	0.46	—	
						1500	0.92	0.70	0.44	—	
						2000	0.89	0.68	0.43	—	
						2500	0.86	0.64	0.40	—	
						3000	0.85	0.61	0.38	—	
						3500	0.78	0.59	0.36	—	
						4000	0.75	0.57	0.35	—	
						4500	0.72	0.54	0.33	—	
						4800	0.70	0.53	0.31	—	

# Altitude Derating—240V

The following graphs show the altitude deratings for 240V PowerFlex 755TS products specified at the rated 60 Hz output fundamental frequency and the maximum rated ambient temperature.

## Altitude Derating Curves—240V AC Frames 1...7

Cat. No. 206...	Frame	240V AC Power Rating				Altitude/Load Derating					
		ND		HD		Altitude m	PWM Frequency kHz				Altitude/Load
		Hp	Cont. Amps	Hp	Cont. Amps		2	4	8	12	
<p style="text-align: center;">All Enclosures</p> <div style="display: flex; justify-content: center; gap: 20px;"> <span>— 2 kHz</span> <span>— 4 kHz</span> <span>— 8 kHz</span> <span>— 12 kHz</span> </div>											
B2P2	1	0.5	2.2	0.5	2.2	0	1.00	1.00	1.00	1.00	
						500	1.00	1.00	1.00	1.00	
						1000	1.00	1.00	1.00	1.00	
						1500	1.00	1.00	1.00	1.00	
						2000	1.00	1.00	1.00	1.00	
						2500	—	—	—	—	
						3000	—	—	—	—	
						3500	—	—	—	—	
						4000	—	—	—	—	
						4500	—	—	—	—	
4800	—	—	—	—							
B4P2	1	1	4.2	0.5	2.2	0	1.00	1.00	1.00	1.00	
						500	1.00	1.00	1.00	1.00	
						1000	1.00	1.00	1.00	1.00	
						1500	1.00	1.00	1.00	1.00	
						2000	1.00	1.00	1.00	1.00	
						2500	—	—	—	—	
						3000	—	—	—	—	
						3500	—	—	—	—	
						4000	—	—	—	—	
						4500	—	—	—	—	
4800	—	—	—	—							

**Altitude Derating Curves—240V AC Frames 1..7 (Continued)**

Cat. No. 206...	Frame	240V AC Power Rating				Altitude/Load Derating					
		ND		HD		Altitude m	PWM Frequency kHz				Altitude/Load
		Hp	Cont. Amps	Hp	Cont. Amps		2	4	8	12	
B6P8	1	2	6.8	1	4.2	0	1.00	1.00	1.00	1.00	<p>All Enclosures</p>
						500	1.00	1.00	1.00	1.00	
						1000	1.00	1.00	1.00	1.00	
						1500	1.00	1.00	1.00	1.00	
						2000	1.00	1.00	1.00	1.00	
						2500	-	-	-	-	
						3000	-	-	-	-	
						3500	-	-	-	-	
						4000	-	-	-	-	
						4500	-	-	-	-	
4800	-	-	-	-							
B9P6	1	3	9.6	2	6.8	0	1.00	1.00	1.00	1.00	
						500	1.00	1.00	1.00	1.00	
						1000	1.00	1.00	1.00	1.00	
						1500	1.00	1.00	1.00	1.00	
						2000	1.00	1.00	1.00	1.00	
						2500	-	-	-	-	
						3000	-	-	-	-	
						3500	-	-	-	-	
						4000	-	-	-	-	
						4500	-	-	-	-	
4800	-	-	-	-							
B015	1	5	15	3	9.6	0	1.00	1.00	1.00	0.87	
						500	1.00	1.00	0.98	0.86	
						1000	1.00	1.00	0.94	0.84	
						1500	1.00	0.98	0.92	0.82	
						2000	1.00	0.96	0.90	0.79	
						2500	-	-	-	-	
						3000	-	-	-	-	
						3500	-	-	-	-	
						4000	-	-	-	-	
						4500	-	-	-	-	
4800	-	-	-	-							

### Altitude Derating Curves—240V AC Frames 1..7 (Continued)

Cat. No. 206...	Frame	240V AC Power Rating				Altitude/Load Derating					
		ND		HD		Altitude m	PWM Frequency kHz				Altitude/Load
		Hp	Cont. Amps	Hp	Cont. Amps		2	4	8	12	
B2P2	2	0.5	2.2	0.5	2.2	0	1.00	1.00	1.00	1.00	<p>All Enclosures</p>
						500	1.00	1.00	1.00	1.00	
						1000	1.00	1.00	1.00	1.00	
						1500	1.00	1.00	1.00	1.00	
						2000	1.00	1.00	1.00	1.00	
						2500	1.00	1.00	1.00	1.00	
						3000	1.00	1.00	1.00	1.00	
						3500	1.00	1.00	1.00	1.00	
						4000	1.00	1.00	1.00	1.00	
						4500	1.00	1.00	1.00	1.00	
4800	1.00	1.00	1.00	1.00							
B4P2	2	1	4.2	1	4.2	0	1.00	1.00	1.00	1.00	
						500	1.00	1.00	1.00	1.00	
						1000	1.00	1.00	1.00	1.00	
						1500	1.00	1.00	1.00	1.00	
						2000	1.00	1.00	1.00	1.00	
						2500	1.00	1.00	1.00	1.00	
						3000	1.00	1.00	1.00	1.00	
						3500	1.00	1.00	1.00	1.00	
						4000	1.00	1.00	1.00	1.00	
						4500	1.00	1.00	1.00	1.00	
4800	1.00	1.00	1.00	1.00							
B6P8	2	2	6.8	2	6.8	0	1.00	1.00	1.00	1.00	
						500	1.00	1.00	1.00	1.00	
						1000	1.00	1.00	1.00	1.00	
						1500	1.00	1.00	1.00	1.00	
						2000	1.00	1.00	1.00	1.00	
						2500	1.00	1.00	1.00	1.00	
						3000	1.00	1.00	1.00	1.00	
						3500	1.00	1.00	1.00	1.00	
						4000	1.00	1.00	1.00	1.00	
						4500	1.00	1.00	1.00	1.00	
4800	1.00	1.00	1.00	1.00							

### Altitude Derating Curves—240V AC Frames 1..7 (Continued)

Cat. No. 206...	Frame	240V AC Power Rating				Altitude/Load Derating					
		ND		HD		Altitude m	PWM Frequency kHz				Altitude/Load
		Hp	Cont. Amps	Hp	Cont. Amps		2	4	8	12	
B9P6	2	3	9.6	3	9.6	0	1.00	1.00	1.00	1.00	<p>All Enclosures</p>
						500	1.00	1.00	1.00	0.99	
						1000	1.00	1.00	1.00	0.97	
						1500	1.00	1.00	1.00	0.95	
						2000	1.00	1.00	1.00	0.94	
						2500	1.00	1.00	1.00	0.91	
						3000	1.00	1.00	1.00	0.88	
						3500	1.00	1.00	1.00	0.86	
						4000	1.00	1.00	1.00	0.84	
						4500	1.00	1.00	1.00	0.82	
4800	1.00	1.00	0.98	0.80							
B015	2	5	15	3	9.6	0	1.00	1.00	1.00	0.95	
						500	1.00	1.00	1.00	0.95	
						1000	1.00	1.00	1.00	0.95	
						1500	1.00	1.00	1.00	0.95	
						2000	1.00	1.00	1.00	0.95	
						2500	1.00	1.00	1.00	0.95	
						3000	1.00	1.00	1.00	0.95	
						3500	1.00	1.00	1.00	0.95	
						4000	1.00	1.00	1.00	0.95	
						4500	1.00	1.00	1.00	0.95	
4800	1.00	1.00	0.98	0.93							
B022	2	7.5	22	5	15	0	1.00	1.00	0.75	0.60	
						500	1.00	1.00	0.73	0.59	
						1000	1.00	1.00	0.72	0.58	
						1500	1.00	1.00	0.71	0.56	
						2000	1.00	1.00	0.69	0.55	
						2500	1.00	0.98	0.66	0.53	
						3000	1.00	0.96	0.63	0.51	
						3500	1.00	0.94	0.62	0.49	
						4000	1.00	0.91	0.60	0.47	
						4500	1.00	0.89	0.58	0.45	
4800	1.00	0.86	0.56	0.44							

### Altitude Derating Curves—240V AC Frames 1..7 (Continued)

Cat. No. 206...	Frame	240V AC Power Rating				Altitude/Load Derating					
		ND		HD		Altitude m	PWM Frequency kHz				Altitude/Load
		Hp	Cont. Amps	Hp	Cont. Amps		2	4	8	12	
B028	3	10	28	7.5	22	0	1.00	1.00	1.00	0.93	<p>All Enclosures</p>
						500	1.00	1.00	1.00	0.92	
						1000	1.00	1.00	1.00	0.91	
						1500	1.00	1.00	1.00	0.89	
						2000	1.00	1.00	1.00	0.88	
						2500	1.00	1.00	1.00	0.86	
						3000	1.00	1.00	1.00	0.84	
						3500	1.00	1.00	1.00	0.82	
						4000	1.00	1.00	1.00	0.80	
						4500	1.00	1.00	1.00	0.78	
4800	1.00	1.00	1.00	0.76							
B042	3	15	42	10	28	0	1.00	0.96	0.59	0.46	
						500	1.00	0.96	0.57	0.45	
						1000	1.00	0.96	0.56	0.44	
						1500	1.00	0.96	0.55	0.43	
						2000	1.00	0.96	0.53	0.42	
						2500	1.00	0.93	0.52	0.40	
						3000	1.00	0.91	0.50	0.39	
						3500	1.00	0.88	0.49	0.38	
						4000	1.00	0.86	0.46	0.36	
						4500	1.00	0.84	0.44	0.34	
4800	1.00	0.82	0.41	0.33							
B054	4	20	54	15	42	0	1.00	0.94	0.68	0.52	
						500	1.00	0.94	0.67	0.51	
						1000	1.00	0.94	0.65	0.50	
						1500	1.00	0.94	0.64	0.49	
						2000	1.00	0.91	0.63	0.48	
						2500	1.00	0.89	0.60	0.47	
						3000	1.00	0.86	0.58	0.45	
						3500	1.00	0.85	0.56	0.43	
						4000	1.00	0.82	0.55	0.42	
						4500	1.00	0.80	0.53	0.40	
4800	1.00	0.79	0.51	0.39							

### Altitude Derating Curves—240V AC Frames 1..7 (Continued)

Cat. No. 206...	Frame	240V AC Power Rating				Altitude/Load Derating					
		ND		HD		Altitude m	PWM Frequency kHz				Altitude/Load
		Hp	Cont. Amps	Hp	Cont. Amps		2	4	8	12	
B055	3	20	55	15	42	0	1.00	1.00	0.80	0.63	<p>All Enclosures</p>
						500	1.00	1.00	0.78	0.61	
						1000	1.00	1.00	0.75	0.59	
						1500	1.00	1.00	0.73	0.57	
						2000	1.00	0.97	0.71	0.55	
						2500	1.00	0.93	0.67	0.52	
						3000	1.00	0.89	0.64	0.49	
						3500	1.00	0.85	0.61	0.47	
						4000	1.00	0.82	0.58	0.45	
						4500	1.00	0.79	0.56	0.43	
4800	1.00	0.74	0.53	0.40							
B070	5	25	70	20	54	0	1.00	1.00	0.78	0.60	
						500	1.00	1.00	0.77	0.59	
						1000	1.00	1.00	0.75	0.57	
						1500	1.00	1.00	0.73	0.55	
						2000	1.00	1.00	0.72	0.54	
						2500	1.00	1.00	0.69	0.53	
						3000	1.00	1.00	0.65	0.50	
						3500	1.00	0.97	0.63	0.48	
						4000	1.00	0.95	0.61	0.46	
						4500	1.00	0.87	0.59	0.44	
4800	1.00	0.86	0.57	0.42							
B071	4	25	71	20	54	0	1.00	0.91	0.68	0.53	
						500	1.00	0.88	0.67	0.51	
						1000	1.00	0.85	0.64	0.50	
						1500	1.00	0.82	0.61	0.48	
						2000	0.97	0.79	0.58	0.45	
						2500	0.92	0.74	0.55	0.43	
						3000	0.87	0.70	0.52	0.40	
						3500	0.83	0.67	0.49	0.38	
						4000	0.80	0.64	0.47	0.36	
						4500	0.77	0.61	0.45	0.35	
4800	0.72	0.57	0.41	0.31							

**Altitude Derating Curves—240V AC Frames 1..7 (Continued)**

Cat. No. 206...	Frame	240V AC Power Rating				Altitude/Load Derating								
		ND		HD		Altitude m	PWM Frequency kHz				Altitude/Load			
		Hp	Cont. Amps	Hp	Cont. Amps		2	4	8	12				
B080	5	30	80	25	70	0	1.00	0.85	0.62	0.48				
						500	1.00	0.85	0.61	0.47				
						1000	1.00	0.85	0.59	0.46				
						1500	1.00	0.82	0.58	0.45				
						2000	1.00	0.81	0.57	0.44				
						2500	1.00	0.78	0.54	0.42				
						3000	1.00	0.76	0.52	0.40				
						3500	1.00	0.73	0.50	0.39				
						4000	1.00	0.71	0.49	0.38				
						4500	1.00	0.69	0.47	0.36				
4800	1.00	0.67	0.45	0.34										
B104	6	40	104	30	80	0	1.00	1.00	0.84	0.66				
						500	1.00	1.00	0.83	0.65				
						1000	1.00	1.00	0.81	0.63				
						1500	1.00	1.00	0.79	0.62				
						2000	1.00	1.00	0.77	0.60				
						2500	1.00	1.00	0.74	0.57				
						3000	1.00	1.00	0.70	0.55				
						3500	1.00	1.00	0.69	0.53				
						4000	1.00	1.00	0.66	0.50				
						4500	1.00	1.00	0.63	0.49				
4800	1.00	1.00	0.61	0.47										
B130	6	50	130	40	104	0	1.00	1.00	0.84	0.66				
						500	1.00	1.00	0.83	0.65				
						1000	1.00	1.00	0.81	0.63				
						1500	1.00	1.00	0.79	0.62				
						2000	1.00	1.00	0.77	0.60				
						2500	1.00	1.00	0.74	0.57				
						3000	1.00	1.00	0.70	0.55				
						3500	1.00	1.00	0.69	0.53				
						4000	1.00	1.00	0.66	0.50				
						4500	1.00	1.00	0.63	0.49				
4800	1.00	1.00	0.61	0.47										

### Altitude Derating Curves—240V AC Frames 1..7 (Continued)

Cat. No. 206...	Frame	240V AC Power Rating				Altitude/Load Derating					
		ND		HD		Altitude m	PWM Frequency kHz				Altitude/Load
		Hp	Cont. Amps	Hp	Cont. Amps		2	4	8	12	
B154	6	60	154	50	130	0	1.00	1.00	0.88	0.68	<p>All Enclosures</p>
						500	1.00	1.00	0.87	0.67	
						1000	1.00	1.00	0.84	0.65	
						1500	1.00	1.00	0.83	0.64	
						2000	1.00	1.00	0.80	0.62	
						2500	1.00	1.00	0.77	0.60	
						3000	1.00	1.00	0.74	0.57	
						3500	1.00	1.00	0.71	0.55	
						4000	1.00	1.00	0.69	0.53	
						4500	1.00	1.00	0.67	0.51	
4800	1.00	1.00	0.65	0.49							
B192	6	75	192	60	154	0	1.00	1.00	0.74	0.58	
						500	1.00	1.00	0.72	0.57	
						1000	1.00	1.00	0.70	0.55	
						1500	1.00	1.00	0.69	0.54	
						2000	1.00	1.00	0.67	0.53	
						2500	1.00	1.00	0.64	0.51	
						3000	1.00	1.00	0.62	0.48	
						3500	1.00	0.96	0.60	0.46	
						4000	1.00	0.94	0.57	0.44	
						4500	1.00	0.91	0.56	0.44	
4800	1.00	0.89	0.54	0.43							
B260	6	100	260	75	192	0	1.00	0.76	0.54	0.41	
						500	1.00	0.74	0.53	0.40	
						1000	0.98	0.72	0.52	0.39	
						1500	0.95	0.70	0.50	0.37	
						2000	0.93	0.68	0.49	0.36	
						2500	0.89	0.66	0.47	0.35	
						3000	0.85	0.62	0.44	0.33	
						3500	0.82	0.59	0.42	0.31	
						4000	0.79	0.56	0.40	0.29	
						4500	0.76	0.53	0.39	0.28	
4800	0.74	0.52	0.38	0.27							

### Altitude Derating Curves—240V AC Frames 1..7 (Continued)

Cat. No. 206...	Frame	240V AC Power Rating				Altitude/Load Derating													
		ND		HD		Altitude m	PWM Frequency kHz				Altitude/Load								
		Hp	Cont. Amps	Hp	Cont. Amps		2	4	8	12	All Enclosures								
B312	7	125	312	100	260	0	1.00	0.74	0.49	—									
						500	0.99	0.74	0.48	—									
						1000	0.95	0.71	0.47	—									
						1500	0.93	0.69	0.45	—									
						2000	0.90	0.67	0.43	—									
						2500	0.86	0.64	0.41	—									
						3000	0.83	0.59	0.39	—									
						3500	0.80	0.57	0.37	—									
						4000	0.75	0.54	0.35	—									
						4500	0.72	0.53	0.34	—									
						4800	0.70	0.52	0.33	—									
B360	7	150	360	125	312	0	1.00	0.74	0.49	—									
						500	0.99	0.74	0.48	—									
						1000	0.95	0.71	0.47	—									
						1500	0.93	0.69	0.45	—									
						2000	0.90	0.67	0.43	—									
						2500	0.86	0.64	0.41	—									
						3000	0.83	0.59	0.39	—									
						3500	0.80	0.57	0.37	—									
						4000	0.75	0.54	0.35	—									
						4500	0.72	0.53	0.34	—									
						4800	0.70	0.52	0.33	—									
B477	7	200	477	125	312	0	1.00	0.72	0.48	—									
						500	1.00	0.68	0.47	—									
						1000	0.99	0.68	0.46	—									
						1500	0.95	0.66	0.44	—									
						2000	0.93	0.63	0.43	—									
						2500	0.89	0.59	0.40	—									
						3000	0.84	0.57	0.38	—									
						3500	0.81	0.54	0.36	—									
						4000	0.79	0.52	0.35	—									
						4500	0.76	0.50	0.33	—									
						4800	0.74	0.50	0.31	—									

# Altitude Derating—400V

The following graphs show the altitude deratings for 400V PowerFlex 755TS products specified at the rated 60 Hz output fundamental frequency and the maximum rated ambient temperature.

## Altitude Derating Curves—400V AC Frames 1..7

Cat. No. 206...	Frame	400V AC Power Rating				Altitude/Load Derating					
		ND		HD		Altitude m	PWM Frequency kHz				Altitude/Load
		kW	Cont. Amps	kW	Cont. Amps		2	4	8	12	
C2P1	1	0.75	2.1	0.5	1.5	0	1.00	1.00	1.00	1.00	<p>All Enclosures</p>
						500	1.00	1.00	1.00	1.00	
						1000	1.00	1.00	1.00	1.00	
						1500	1.00	1.00	1.00	1.00	
						2000	1.00	1.00	1.00	1.00	
						2500	—	—	—	—	
						3000	—	—	—	—	
						3500	—	—	—	—	
						4000	—	—	—	—	
						4500	—	—	—	—	
4800	—	—	—	—							
C3P5	1	1.5	3.5	0.75	3.5	0	1.00	1.00	1.00	1.00	
						500	1.00	1.00	1.00	1.00	
						1000	1.00	1.00	1.00	1.00	
						1500	1.00	1.00	1.00	1.00	
						2000	1.00	1.00	1.00	1.00	
						2500	—	—	—	—	
						3000	—	—	—	—	
						3500	—	—	—	—	
						4000	—	—	—	—	
						4500	—	—	—	—	
4800	—	—	—	—							

### Altitude Derating Curves—400V AC Frames 1..7 (Continued)

Cat. No. 206...	Frame	400V AC Power Rating				Altitude/Load Derating					
		ND		HD		Altitude m	PWM Frequency kHz				Altitude/Load
		kW	Cont. Amps	kW	Cont. Amps		2	4	8	12	
C5P0	1	2.2	5	1.5	3.5	0	1.00	1.00	1.00	1.00	<p>All Enclosures</p>
						500	1.00	1.00	1.00	1.00	
						1000	1.00	1.00	1.00	1.00	
						1500	1.00	1.00	1.00	1.00	
						2000	1.00	1.00	1.00	1.00	
						2500	-	-	-	-	
						3000	-	-	-	-	
						3500	-	-	-	-	
						4000	-	-	-	-	
						4500	-	-	-	-	
4800	-	-	-	-							
C8P7	1	4	8.7	2.2	5	0	1.00	1.00	1.00	1.00	
						500	1.00	1.00	1.00	1.00	
						1000	1.00	1.00	1.00	1.00	
						1500	1.00	1.00	1.00	1.00	
						2000	1.00	1.00	1.00	1.00	
						2500	-	-	-	-	
						3000	-	-	-	-	
						3500	-	-	-	-	
						4000	-	-	-	-	
						4500	-	-	-	-	
4800	-	-	-	-							
C011	1	5.5	11.5	4	8.7	0	1.00	1.00	1.00	1.00	
						500	1.00	1.00	1.00	1.00	
						1000	1.00	1.00	1.00	1.00	
						1500	1.00	1.00	1.00	1.00	
						2000	1.00	1.00	1.00	1.00	
						2500	-	-	-	-	
						3000	-	-	-	-	
						3500	-	-	-	-	
						4000	-	-	-	-	
						4500	-	-	-	-	
4800	-	-	-	-							

### Altitude Derating Curves—400V AC Frames 1..7 (Continued)

Cat. No. 206...	Frame	400V AC Power Rating				Altitude/Load Derating					
		ND		HD		Altitude m	PWM Frequency kHz				Altitude/Load
		kW	Cont. Amps	kW	Cont. Amps		2	4	8	12	
C015	1	7.5	15.4	5.5	11.5	0	1.00	1.00	1.00	0.87	
						500	1.00	0.98	0.98	0.86	
						1000	1.00	0.95	0.94	0.84	
						1500	1.00	0.92	0.92	0.82	
						2000	1.00	0.90	0.90	0.79	
						2500	–	–	–	–	
						3000	–	–	–	–	
						3500	–	–	–	–	
						4000	–	–	–	–	
						4500	–	–	–	–	
4800	–	–	–	–							
C2P1	2	0.75	2.1	0.5	1.5	0	1.00	1.00	1.00	1.00	
						500	1.00	1.00	1.00	1.00	
						1000	1.00	1.00	1.00	1.00	
						1500	1.00	1.00	1.00	1.00	
						2000	1.00	1.00	1.00	1.00	
						2500	1.00	1.00	1.00	1.00	
						3000	1.00	1.00	1.00	1.00	
						3500	1.00	1.00	1.00	1.00	
						4000	1.00	1.00	1.00	1.00	
						4500	1.00	1.00	1.00	1.00	
4800	1.00	1.00	1.00	1.00							
C3P5	2	1.5	3.5	0.75	2.1	0	1.00	1.00	1.00	1.00	
						500	1.00	1.00	1.00	1.00	
						1000	1.00	1.00	1.00	1.00	
						1500	1.00	1.00	1.00	1.00	
						2000	1.00	1.00	1.00	1.00	
						2500	1.00	1.00	1.00	1.00	
						3000	1.00	1.00	1.00	1.00	
						3500	1.00	1.00	1.00	1.00	
						4000	1.00	1.00	1.00	1.00	
						4500	1.00	1.00	1.00	1.00	
4800	1.00	1.00	1.00	1.00							

### Altitude Derating Curves—400V AC Frames 1..7 (Continued)

Cat. No. 206...	Frame	400V AC Power Rating				Altitude/Load Derating					
		ND		HD		Altitude	PWM Frequency kHz				Altitude/Load
		kW	Cont. Amps	kW	Cont. Amps	m	2	4	8	12	
C5P0	2	2.2	5	1.5	3.5	0	1.00	1.00	1.00	1.00	<p>All Enclosures</p>
						500	1.00	1.00	1.00	1.00	
						1000	1.00	1.00	1.00	1.00	
						1500	1.00	1.00	1.00	1.00	
						2000	1.00	1.00	1.00	1.00	
						2500	1.00	1.00	1.00	1.00	
						3000	1.00	1.00	1.00	1.00	
						3500	1.00	1.00	1.00	1.00	
						4000	1.00	1.00	1.00	1.00	
						4500	1.00	1.00	1.00	1.00	
						4800	1.00	1.00	1.00	1.00	
C8P7	2	4	8.7	2.2	5	0	1.00	1.00	1.00	1.00	
						500	1.00	1.00	1.00	1.00	
						1000	1.00	1.00	1.00	1.00	
						1500	1.00	1.00	1.00	1.00	
						2000	1.00	1.00	1.00	1.00	
						2500	1.00	1.00	1.00	1.00	
						3000	1.00	1.00	1.00	1.00	
						3500	1.00	1.00	1.00	1.00	
						4000	1.00	1.00	1.00	1.00	
						4500	1.00	1.00	1.00	1.00	
						4800	1.00	1.00	1.00	1.00	
C011	2	5.5	11.5	4	8.7	0	1.00	1.00	1.00	1.00	
						500	1.00	1.00	1.00	0.99	
						1000	1.00	1.00	1.00	0.97	
						1500	1.00	1.00	1.00	0.95	
						2000	1.00	1.00	1.00	0.94	
						2500	1.00	1.00	1.00	0.91	
						3000	1.00	1.00	1.00	0.88	
						3500	1.00	1.00	1.00	0.86	
						4000	1.00	1.00	1.00	0.84	
						4500	1.00	1.00	1.00	0.82	
						4800	1.00	1.00	0.98	0.80	

### Altitude Derating Curves—400V AC Frames 1..7 (Continued)

Cat. No. 206...	Frame	400V AC Power Rating				Altitude/Load Derating					
		ND		HD		Altitude	PWM Frequency kHz				Altitude/Load
		kW	Cont. Amps	kW	Cont. Amps	m	2	4	8	12	
C015	2	7.5	15.4	5.5	11.5	0	1.00	1.00	1.00	0.95	<p>All Enclosures</p>
						500	1.00	1.00	1.00	0.95	
						1000	1.00	1.00	1.00	0.95	
						1500	1.00	1.00	1.00	0.95	
						2000	1.00	1.00	1.00	0.95	
						2500	1.00	1.00	1.00	0.95	
						3000	1.00	1.00	1.00	0.95	
						3500	1.00	1.00	1.00	0.95	
						4000	1.00	1.00	1.00	0.95	
						4500	1.00	1.00	1.00	0.95	
						4800	1.00	1.00	0.98	0.93	
C022	2	11	22	7.5	15.4	0	1.00	1.00	0.75	0.60	
						500	1.00	1.00	0.73	0.59	
						1000	1.00	1.00	0.72	0.58	
						1500	1.00	1.00	0.71	0.56	
						2000	1.00	1.00	0.69	0.55	
						2500	1.00	1.00	0.66	0.53	
						3000	1.00	1.00	0.63	0.51	
						3500	1.00	0.98	0.62	0.49	
						4000	1.00	0.95	0.60	0.47	
						4500	1.00	0.93	0.58	0.45	
						4800	1.00	0.90	0.56	0.44	
C030	3	15	30	11	22	0	1.00	1.00	1.00	0.93	
						500	1.00	1.00	1.00	0.92	
						1000	1.00	1.00	1.00	0.91	
						1500	1.00	1.00	1.00	0.89	
						2000	1.00	1.00	1.00	0.88	
						2500	1.00	1.00	1.00	0.86	
						3000	1.00	1.00	1.00	0.84	
						3500	1.00	1.00	1.00	0.82	
						4000	1.00	1.00	1.00	0.80	
						4500	1.00	1.00	1.00	0.78	
						4800	1.00	1.00	1.00	0.76	

**Altitude Derating Curves—400V AC Frames 1..7 (Continued)**

Cat. No. 206...	Frame	400V AC Power Rating				Altitude/Load Derating					
		ND		HD		Altitude m	PWM Frequency kHz				Altitude/Load
		kW	Cont. Amps	kW	Cont. Amps		2	4	8	12	
C037	3	18.5	37	15	30	0	1.00	0.97	0.80	0.74	<p>All Enclosures</p>
						500	1.00	0.97	0.79	0.73	
						1000	1.00	0.97	0.78	0.72	
						1500	1.00	0.97	0.78	0.71	
						2000	1.00	0.97	0.76	0.70	
						2500	1.00	0.97	0.74	0.68	
						3000	1.00	0.97	0.73	0.66	
						3500	1.00	0.97	0.71	0.65	
						4000	1.00	0.97	0.69	0.63	
						4500	1.00	0.97	0.68	0.62	
						4800	1.00	0.97	0.66	0.61	
C043	3	22	43	18.5	37	0	1.00	0.96	0.66	0.46	
						500	1.00	0.96	0.64	0.45	
						1000	1.00	0.96	0.63	0.44	
						1500	1.00	0.96	0.62	0.43	
						2000	1.00	0.96	0.60	0.42	
						2500	1.00	0.95	0.58	0.40	
						3000	1.00	0.93	0.56	0.39	
						3500	1.00	0.90	0.54	0.38	
						4000	1.00	0.87	0.52	0.36	
						4500	1.00	0.84	0.49	0.34	
						4800	1.00	0.82	0.46	0.33	
C060	4	30	60	22	43	0	1.00	1.00	0.85	0.65	
						500	1.00	1.00	0.84	0.64	
						1000	1.00	1.00	0.82	0.62	
						1500	1.00	1.00	0.81	0.61	
						2000	1.00	1.00	0.79	0.60	
						2500	1.00	1.00	0.76	0.58	
						3000	1.00	1.00	0.73	0.55	
						3500	1.00	1.00	0.72	0.53	
						4000	1.00	1.00	0.69	0.52	
						4500	1.00	1.00	0.67	0.50	
						4800	1.00	1.00	0.65	0.48	

### Altitude Derating Curves—400V AC Frames 1..7 (Continued)

Cat. No. 206...	Frame	400V AC Power Rating				Altitude/Load Derating					
		ND		HD		Altitude m	PWM Frequency kHz				Altitude/Load
		kW	Cont. Amps	kW	Cont. Amps		2	4	8	12	
C061	3	30	61	22	43	0	1.00	0.97	0.80	0.63	
						500	1.00	0.95	0.78	0.61	
						1000	1.00	0.92	0.75	0.59	
						1500	1.00	0.89	0.73	0.57	
						2000	1.00	0.87	0.71	0.55	
						2500	1.00	0.83	0.67	0.52	
						3000	1.00	0.80	0.64	0.49	
						3500	1.00	0.76	0.61	0.47	
						4000	1.00	0.73	0.58	0.45	
						4500	1.00	0.70	0.56	0.43	
4800	1.00	0.67	0.53	0.40							
C072	4	37	72	30	60	0	1.00	0.92	0.68	0.52	
						500	1.00	0.91	0.67	0.51	
						1000	1.00	0.88	0.65	0.50	
						1500	1.00	0.87	0.64	0.49	
						2000	1.00	0.86	0.63	0.48	
						2500	1.00	0.84	0.60	0.47	
						3000	1.00	0.82	0.58	0.45	
						3500	0.99	0.79	0.56	0.43	
						4000	0.98	0.77	0.55	0.42	
						4500	0.97	0.75	0.53	0.40	
4800	0.96	0.73	0.51	0.39							
C073	4	37	73	30	60	0	1.00	1.00	0.80	0.62	
						500	1.00	0.99	0.78	0.59	
						1000	1.00	0.96	0.75	0.58	
						1500	1.00	0.95	0.71	0.56	
						2000	1.00	0.94	0.68	0.53	
						2500	1.00	0.91	0.65	0.51	
						3000	1.00	0.89	0.61	0.47	
						3500	0.99	0.86	0.57	0.44	
						4000	0.98	0.84	0.55	0.42	
						4500	0.97	0.81	0.52	0.40	
4800	0.96	0.79	0.49	0.37							

### Altitude Derating Curves—400V AC Frames 1..7 (Continued)

Cat. No. 206...	Frame	400V AC Power Rating				Altitude/Load Derating					
		ND		HD		Altitude m	PWM Frequency kHz				Altitude/Load
		kW	Cont. Amps	kW	Cont. Amps		2	4	8	12	
C085	5	45	85	37	72	0	1.00	1.00	0.78	0.60	
						500	1.00	1.00	0.77	0.59	
						1000	1.00	1.00	0.75	0.57	
						1500	1.00	1.00	0.73	0.55	
						2000	1.00	1.00	0.72	0.54	
						2500	1.00	1.00	0.69	0.53	
						3000	1.00	0.99	0.65	0.50	
						3500	1.00	0.96	0.63	0.48	
						4000	1.00	0.92	0.61	0.46	
						4500	1.00	0.90	0.59	0.44	
4800	1.00	0.88	0.57	0.42							
C086	4	45	86	37	72	0	1.00	0.87	0.68	0.53	
						500	1.00	0.86	0.67	0.51	
						1000	1.00	0.84	0.64	0.50	
						1500	1.00	0.83	0.61	0.48	
						2000	1.00	0.82	0.58	0.45	
						2500	1.00	0.79	0.55	0.43	
						3000	1.00	0.77	0.52	0.40	
						3500	0.99	0.75	0.49	0.38	
						4000	0.98	0.73	0.47	0.36	
						4500	0.97	0.70	0.45	0.35	
4800	0.96	0.69	0.41	0.31							
C104	5	55	104	45	85	0	1.00	0.82	0.62	0.48	
						500	1.00	0.82	0.61	0.47	
						1000	1.00	0.80	0.59	0.46	
						1500	1.00	0.79	0.58	0.45	
						2000	1.00	0.77	0.57	0.44	
						2500	1.00	0.75	0.54	0.42	
						3000	1.00	0.72	0.52	0.40	
						3500	0.99	0.70	0.50	0.39	
						4000	0.98	0.68	0.49	0.38	
						4500	0.96	0.66	0.47	0.36	
4800	0.95	0.65	0.45	0.34							

# Altitude Derating Curves—400V AC Frames 1..7 (Continued)

Cat. No. 206...	Frame	400V AC Power Rating				Altitude/Load Derating					
		ND		HD		Altitude m	PWM Frequency kHz				Altitude/Load
		kW	Cont. Amps	kW	Cont. Amps		2	4	8	12	
C140	6	75	140	55	104	0	1.00	1.00	0.84	0.66	<p>All Enclosures</p>
						500	1.00	1.00	0.83	0.65	
						1000	1.00	1.00	0.81	0.63	
						1500	1.00	1.00	0.79	0.62	
						2000	1.00	1.00	0.77	0.60	
						2500	1.00	1.00	0.74	0.57	
						3000	1.00	1.00	0.70	0.55	
						3500	1.00	1.00	0.69	0.53	
						4000	1.00	1.00	0.66	0.50	
						4500	1.00	1.00	0.63	0.49	
4800	1.00	1.00	0.61	0.47							
C170	6	90	170	75	140	0	1.00	1.00	0.88	0.68	
						500	1.00	1.00	0.87	0.67	
						1000	1.00	1.00	0.84	0.65	
						1500	1.00	1.00	0.83	0.64	
						2000	1.00	1.00	0.80	0.62	
						2500	1.00	1.00	0.77	0.60	
						3000	1.00	1.00	0.74	0.57	
						3500	1.00	1.00	0.71	0.55	
						4000	1.00	1.00	0.69	0.53	
						4500	1.00	1.00	0.67	0.51	
4800	1.00	1.00	0.65	0.49							
C205	6	110	205	90	170	0	1.00	0.96	0.74	0.58	
						500	1.00	0.96	0.72	0.57	
						1000	1.00	0.96	0.70	0.55	
						1500	1.00	0.96	0.69	0.54	
						2000	1.00	0.96	0.67	0.53	
						2500	1.00	0.95	0.64	0.51	
						3000	1.00	0.92	0.62	0.48	
						3500	1.00	0.90	0.60	0.46	
						4000	1.00	0.87	0.57	0.44	
						4500	1.00	0.84	0.56	0.44	
4800	1.00	0.83	0.54	0.43							

### Altitude Derating Curves—400V AC Frames 1..7 (Continued)

Cat. No. 206...	Frame	400V AC Power Rating				Altitude/Load Derating					
		ND		HD		Altitude m	PWM Frequency kHz				Altitude/Load
		kW	Cont. Amps	kW	Cont. Amps		2	4	8	12	
C260	6	132	260	110	205	0	1.00	0.76	0.54	0.41	<p>All Enclosures</p>
						500	1.00	0.75	0.53	0.40	
						1000	0.98	0.73	0.52	0.39	
						1500	0.95	0.70	0.50	0.37	
						2000	0.93	0.69	0.49	0.36	
						2500	0.89	0.65	0.47	0.35	
						3000	0.85	0.63	0.44	0.33	
						3500	0.83	0.60	0.42	0.31	
						4000	0.79	0.58	0.40	0.29	
						4500	0.76	0.55	0.39	0.28	
						4800	0.74	0.54	0.38	0.27	
C302	7	160	302	132	260	0	1.00	0.95	0.59	—	
						500	1.00	0.93	0.58	—	
						1000	1.00	0.90	0.56	—	
						1500	1.00	0.87	0.54	—	
						2000	1.00	0.85	0.52	—	
						2500	1.00	0.81	0.49	—	
						3000	1.00	0.76	0.47	—	
						3500	0.98	0.74	0.45	—	
						4000	0.96	0.71	0.43	—	
						4500	0.94	0.68	0.41	—	
						4800	0.93	0.67	0.39	—	
C367	7	200	367	160	302	0	1.00	0.78	0.49	—	
						500	1.00	0.73	0.48	—	
						1000	1.00	0.72	0.47	—	
						1500	0.96	0.69	0.45	—	
						2000	0.94	0.67	0.43	—	
						2500	0.90	0.63	0.41	—	
						3000	0.86	0.61	0.39	—	
						3500	0.83	0.59	0.37	—	
						4000	0.80	0.55	0.35	—	
						4500	0.77	0.53	0.34	—	
						4800	0.75	0.52	0.33	—	

**Altitude Derating Curves—400V AC Frames 1..7 (Continued)**

Cat. No. 206...	Frame	400V AC Power Rating				Altitude/Load Derating					
		ND		HD		Altitude m	PWM Frequency kHz				Altitude/Load
		kW	Cont. Amps	kW	Cont. Amps		2	4	8	12	
All Enclosures 											
C456	7	250	456	200	367	0	1.00	0.82	0.58	—	
						500	0.97	0.79	0.57	—	
						1000	0.94	0.76	0.55	—	
						1500	0.92	0.74	0.53	—	
						2000	0.89	0.72	0.51	—	
						2500	0.86	0.68	0.49	—	
						3000	0.85	0.65	0.46	—	
						3500	0.78	0.62	0.44	—	
						4000	0.75	0.59	0.41	—	
						4500	0.72	0.56	0.40	—	
						4800	0.70	0.55	0.39	—	
C477	7	270	477	200	367	0	1.00	0.78	0.48	—	
						500	0.97	0.75	0.47	—	
						1000	0.94	0.72	0.46	—	
						1500	0.92	0.70	0.44	—	
						2000	0.89	0.68	0.43	—	
						2500	0.86	0.64	0.40	—	
						3000	0.85	0.61	0.38	—	
						3500	0.78	0.59	0.36	—	
						4000	0.75	0.57	0.35	—	
						4500	0.72	0.54	0.33	—	
						4800	0.70	0.53	0.31	—	

# Altitude Derating—480V

The following graphs show the altitude deratings for 480V PowerFlex 755TS products specified at the rated 60 Hz output fundamental frequency and the maximum rated ambient temperature.

## Altitude Derating Curves—480V AC Frames 1...7

Cat. No. 206...	Frame	480V AC Power Rating				Altitude/Load Derating					
		ND		HD		Altitude m	PWM Frequency kHz				Altitude/Load
		Hp	Cont. Amps	Hp	Cont. Amps		2	4	8	12	
D2P1	1	1	2.1	0.5	1	0	1.00	1.00	1.00	1.00	<p>All Enclosures</p>
						500	1.00	1.00	1.00	1.00	
						1000	1.00	1.00	1.00	1.00	
						1500	1.00	1.00	1.00	1.00	
						2000	1.00	1.00	1.00	1.00	
						2500	—	—	—	—	
						3000	—	—	—	—	
						3500	—	—	—	—	
						4000	—	—	—	—	
						4500	—	—	—	—	
4800	—	—	—	—							
D3P4	1	2	3.4	1	2.1	0	1.00	1.00	1.00	1.00	
						500	1.00	1.00	1.00	1.00	
						1000	1.00	1.00	1.00	1.00	
						1500	1.00	1.00	1.00	1.00	
						2000	1.00	1.00	1.00	1.00	
						2500	—	—	—	—	
						3000	—	—	—	—	
						3500	—	—	—	—	
						4000	—	—	—	—	
						4500	—	—	—	—	
4800	—	—	—	—							

### Altitude Derating Curves—480V AC Frames 1..7 (Continued)

Cat. No. 206...	Frame	480V AC Power Rating				Altitude/Load Derating					
		ND		HD		Altitude m	PWM Frequency kHz				Altitude/Load
		Hp	Cont. Amps	Hp	Cont. Amps		2	4	8	12	
D5PO	1	3	5	2	3.4	0	1.00	1.00	1.00	1.00	<p>All Enclosures</p> <p>— 2 kHz    — 8 kHz — 4 kHz    — 12 kHz</p>
						500	1.00	1.00	1.00	1.00	
						1000	1.00	1.00	1.00	1.00	
						1500	1.00	1.00	1.00	1.00	
						2000	1.00	1.00	1.00	1.00	
						2500	—	—	—	—	
						3000	—	—	—	—	
						3500	—	—	—	—	
						4000	—	—	—	—	
						4500	—	—	—	—	
4800	—	—	—	—							
D8PO	1	5	8	3	5	0	1.00	1.00	1.00	1.00	
						500	1.00	1.00	1.00	1.00	
						1000	1.00	1.00	1.00	1.00	
						1500	1.00	1.00	1.00	1.00	
						2000	1.00	1.00	1.00	1.00	
						2500	—	—	—	—	
						3000	—	—	—	—	
						3500	—	—	—	—	
						4000	—	—	—	—	
						4500	—	—	—	—	
4800	—	—	—	—							
D011	1	7.5	11	5	8	0	1.00	1.00	1.00	1.00	
						500	1.00	1.00	1.00	1.00	
						1000	1.00	1.00	1.00	1.00	
						1500	1.00	1.00	1.00	1.00	
						2000	1.00	1.00	1.00	1.00	
						2500	—	—	—	—	
						3000	—	—	—	—	
						3500	—	—	—	—	
						4000	—	—	—	—	
						4500	—	—	—	—	
4800	—	—	—	—							

### Altitude Derating Curves—480V AC Frames 1..7 (Continued)

Cat. No. 206...	Frame	480V AC Power Rating				Altitude/Load Derating					
		ND		HD		Altitude m	PWM Frequency kHz				Altitude/Load
		Hp	Cont. Amps	Hp	Cont. Amps		2	4	8	12	
D014	1	10	14	7.5	11	0	1.00	1.00	1.00	0.87	<p>All Enclosures</p>
						500	1.00	1.00	0.98	0.86	
						1000	1.00	1.00	0.94	0.84	
						1500	1.00	0.98	0.92	0.82	
						2000	1.00	0.96	0.90	0.79	
						2500	–	–	–	–	
						3000	–	–	–	–	
						3500	–	–	–	–	
						4000	–	–	–	–	
						4500	–	–	–	–	
4800	–	–	–	–							
D2P1	2	1	2.1	0.5	1	0	1.00	1.00	1.00	1.00	
						500	1.00	1.00	1.00	1.00	
						1000	1.00	1.00	1.00	1.00	
						1500	1.00	1.00	1.00	1.00	
						2000	1.00	1.00	1.00	1.00	
						2500	1.00	1.00	1.00	1.00	
						3000	1.00	1.00	1.00	1.00	
						3500	1.00	1.00	1.00	1.00	
						4000	1.00	1.00	1.00	1.00	
						4500	1.00	1.00	1.00	1.00	
4800	1.00	1.00	1.00	1.00							
D3P4	2	2	3.4	1	2.1	0	1.00	1.00	1.00	1.00	
						500	1.00	1.00	1.00	1.00	
						1000	1.00	1.00	1.00	1.00	
						1500	1.00	1.00	1.00	1.00	
						2000	1.00	1.00	1.00	1.00	
						2500	1.00	1.00	1.00	1.00	
						3000	1.00	1.00	1.00	1.00	
						3500	1.00	1.00	1.00	1.00	
						4000	1.00	1.00	1.00	1.00	
						4500	1.00	1.00	1.00	1.00	
4800	1.00	1.00	1.00	1.00							

### Altitude Derating Curves—480V AC Frames 1..7 (Continued)

Cat. No. 20G...	Frame	480V AC Power Rating				Altitude/Load Derating					
		ND		HD		Altitude m	PWM Frequency kHz				Altitude/Load
		Hp	Cont. Amps	Hp	Cont. Amps		2	4	8	12	
D5PO	2	3	5	2	3.4	0	1.00	1.00	1.00	1.00	<p>All Enclosures</p>
						500	1.00	1.00	1.00	1.00	
						1000	1.00	1.00	1.00	1.00	
						1500	1.00	1.00	1.00	1.00	
						2000	1.00	1.00	1.00	1.00	
						2500	1.00	1.00	1.00	1.00	
						3000	1.00	1.00	1.00	1.00	
						3500	1.00	1.00	1.00	1.00	
						4000	1.00	1.00	1.00	1.00	
						4800	1.00	1.00	1.00	1.00	
D8PO	2	5	8	3	5	0	1.00	1.00	1.00	1.00	
						500	1.00	1.00	1.00	1.00	
						1000	1.00	1.00	1.00	1.00	
						1500	1.00	1.00	1.00	1.00	
						2000	1.00	1.00	1.00	1.00	
						2500	1.00	1.00	1.00	1.00	
						3000	1.00	1.00	1.00	1.00	
						3500	1.00	1.00	1.00	1.00	
						4000	1.00	1.00	1.00	1.00	
						4800	1.00	1.00	1.00	1.00	
D011	2	7.5	11	5	8	0	1.00	1.00	1.00	1.00	
						500	1.00	1.00	1.00	0.99	
						1000	1.00	1.00	1.00	0.97	
						1500	1.00	1.00	1.00	0.95	
						2000	1.00	1.00	1.00	0.94	
						2500	1.00	1.00	1.00	0.91	
						3000	1.00	1.00	1.00	0.88	
						3500	1.00	1.00	1.00	0.86	
						4000	1.00	1.00	1.00	0.84	
						4800	1.00	1.00	0.98	0.80	

### Altitude Derating Curves—480V AC Frames 1..7 (Continued)

Cat. No. 206...	Frame	480V AC Power Rating				Altitude/Load Derating					
		ND		HD		Altitude	PWM Frequency kHz				Altitude/Load
		Hp	Cont. Amps	Hp	Cont. Amps	m	2	4	8	12	
D014	2	10	14	7.5	11	0	1.00	1.00	1.00	0.95	<p>All Enclosures</p>
						500	1.00	1.00	1.00	0.95	
						1000	1.00	1.00	1.00	0.95	
						1500	1.00	1.00	1.00	0.95	
						2000	1.00	1.00	1.00	0.95	
						2500	1.00	1.00	1.00	0.95	
						3000	1.00	1.00	1.00	0.95	
						3500	1.00	1.00	1.00	0.95	
						4000	1.00	1.00	1.00	0.95	
						4500	1.00	1.00	1.00	0.95	
4800	1.00	1.00	0.98	0.93							
D022	2	15	22	10	14	0	1.00	1.00	0.75	0.60	
						500	1.00	1.00	0.73	0.59	
						1000	1.00	1.00	0.72	0.58	
						1500	1.00	1.00	0.71	0.56	
						2000	1.00	1.00	0.69	0.55	
						2500	1.00	0.98	0.66	0.53	
						3000	1.00	0.96	0.63	0.51	
						3500	1.00	0.94	0.62	0.49	
						4000	1.00	0.91	0.60	0.47	
						4500	1.00	0.89	0.58	0.45	
4800	1.00	0.86	0.56	0.44							
D027	3	20	27	15	22	0	1.00	1.00	1.00	0.93	
						500	1.00	1.00	1.00	0.92	
						1000	1.00	1.00	1.00	0.91	
						1500	1.00	1.00	1.00	0.89	
						2000	1.00	1.00	1.00	0.88	
						2500	1.00	1.00	1.00	0.86	
						3000	1.00	1.00	1.00	0.84	
						3500	1.00	1.00	1.00	0.82	
						4000	1.00	1.00	1.00	0.80	
						4500	1.00	1.00	1.00	0.78	
4800	1.00	1.00	1.00	0.76							

### Altitude Derating Curves—480V AC Frames 1..7 (Continued)

Cat. No. 206...	Frame	480V AC Power Rating				Altitude/Load Derating					
		ND		HD		Altitude m	PWM Frequency kHz				Altitude/Load
		Hp	Cont. Amps	Hp	Cont. Amps		2	4	8	12	
D034	3	25	34	20	27	0	1.00	1.00	0.87	0.74	<p>All Enclosures</p>
						500	1.00	1.00	0.86	0.73	
						1000	1.00	1.00	0.85	0.72	
						1500	1.00	1.00	0.84	0.71	
						2000	1.00	1.00	0.83	0.70	
						2500	1.00	1.00	0.81	0.68	
						3000	1.00	1.00	0.79	0.66	
						3500	1.00	1.00	0.77	0.65	
						4000	1.00	1.00	0.75	0.63	
						4500	1.00	1.00	0.74	0.62	
4800	1.00	1.00	0.72	0.61							
D040	3	30	40	25	34	0	1.00	0.96	0.59	0.46	
						500	1.00	0.96	0.57	0.45	
						1000	1.00	0.96	0.56	0.44	
						1500	1.00	0.96	0.55	0.43	
						2000	1.00	0.96	0.53	0.42	
						2500	1.00	0.95	0.52	0.40	
						3000	1.00	0.93	0.50	0.39	
						3500	1.00	0.90	0.49	0.38	
						4000	1.00	0.87	0.46	0.36	
						4500	1.00	0.84	0.44	0.34	
4800	1.00	0.82	0.41	0.33							
D052	4	40	52	30	40	0	1.00	1.00	0.85	0.65	
						500	1.00	1.00	0.84	0.64	
						1000	1.00	1.00	0.82	0.62	
						1500	1.00	1.00	0.81	0.61	
						2000	1.00	1.00	0.79	0.60	
						2500	1.00	1.00	0.76	0.58	
						3000	1.00	1.00	0.73	0.55	
						3500	1.00	1.00	0.72	0.53	
						4000	1.00	1.00	0.69	0.52	
						4500	1.00	1.00	0.67	0.50	
4800	1.00	1.00	0.65	0.48							

### Altitude Derating Curves—480V AC Frames 1..7 (Continued)

Cat. No. 206...	Frame	480V AC Power Rating				Altitude/Load Derating					
		ND		HD		Altitude m	PWM Frequency kHz				Altitude/Load
		Hp	Cont. Amps	Hp	Cont. Amps		2	4	8	12	
D053	3	30	61	22	43	0	1.00	1.00	0.80	0.63	<p>All Enclosures</p>
						500	1.00	1.00	0.78	0.61	
						1000	1.00	1.00	0.75	0.59	
						1500	1.00	1.00	0.73	0.57	
						2000	1.00	1.00	0.71	0.55	
						2500	1.00	0.97	0.67	0.52	
						3000	1.00	0.89	0.64	0.49	
						3500	1.00	0.85	0.61	0.47	
						4000	1.00	0.82	0.58	0.45	
						4500	1.00	0.79	0.56	0.43	
4800	1.00	0.74	0.53	0.40							
D065	4	50	65	40	52	0	1.00	0.94	0.68	0.52	
						500	1.00	0.94	0.67	0.51	
						1000	1.00	0.94	0.65	0.50	
						1500	1.00	0.94	0.64	0.49	
						2000	1.00	0.91	0.63	0.48	
						2500	1.00	0.89	0.60	0.47	
						3000	1.00	0.86	0.58	0.45	
						3500	1.00	0.85	0.56	0.43	
						4000	1.00	0.82	0.55	0.42	
						4500	1.00	0.80	0.53	0.40	
4800	1.00	0.79	0.51	0.39							
D066	4	50	66	40	52	0	1.00	1.00	0.80	0.62	
						500	1.00	1.00	0.78	0.59	
						1000	1.00	1.00	0.75	0.58	
						1500	1.00	1.00	0.71	0.56	
						2000	1.00	0.97	0.68	0.53	
						2500	1.00	0.95	0.65	0.51	
						3000	1.00	0.92	0.61	0.47	
						3500	1.00	0.90	0.57	0.44	
						4000	1.00	0.87	0.55	0.42	
						4500	1.00	0.85	0.52	0.40	
4800	1.00	0.84	0.49	0.37							

### Altitude Derating Curves—480V AC Frames 1..7 (Continued)

Cat. No. 206...	Frame	480V AC Power Rating				Altitude/Load Derating					
		ND		HD		Altitude m	PWM Frequency kHz				Altitude/Load
		Hp	Cont. Amps	Hp	Cont. Amps		2	4	8	12	
D077	5	60	77	50	65	0	1.00	1.00	0.78	0.60	<p>All Enclosures</p>
						500	1.00	1.00	0.77	0.59	
						1000	1.00	1.00	0.75	0.57	
						1500	1.00	1.00	0.73	0.55	
						2000	1.00	1.00	0.72	0.54	
						2500	1.00	1.00	0.69	0.53	
						3000	1.00	1.00	0.65	0.50	
						3500	1.00	0.97	0.63	0.48	
						4000	1.00	0.95	0.61	0.46	
						4500	1.00	0.87	0.59	0.44	
4800	1.00	0.86	0.57	0.42							
D078	4	60	78	50	65	0	1.00	0.91	0.68	0.53	
						500	1.00	0.88	0.67	0.51	
						1000	1.00	0.85	0.64	0.50	
						1500	1.00	0.82	0.61	0.48	
						2000	0.97	0.79	0.58	0.45	
						2500	0.92	0.74	0.55	0.43	
						3000	0.87	0.70	0.52	0.40	
						3500	0.83	0.67	0.49	0.38	
						4000	0.80	0.64	0.47	0.36	
						4500	0.77	0.61	0.45	0.35	
4800	0.72	0.57	0.41	0.31							
D096	5	75	96	60	77	0	1.00	0.85	0.62	0.48	
						500	1.00	0.85	0.61	0.47	
						1000	1.00	0.85	0.59	0.46	
						1500	1.00	0.82	0.58	0.45	
						2000	1.00	0.81	0.57	0.44	
						2500	1.00	0.78	0.54	0.42	
						3000	1.00	0.76	0.52	0.40	
						3500	1.00	0.73	0.50	0.39	
						4000	1.00	0.71	0.49	0.38	
						4500	1.00	0.69	0.47	0.36	
4800	1.00	0.67	0.45	0.34							

### Altitude Derating Curves—480V AC Frames 1..7 (Continued)

Cat. No. 206...	Frame	480V AC Power Rating				Altitude/Load Derating					
		ND		HD		Altitude m	PWM Frequency kHz				Altitude/Load
		Hp	Cont. Amps	Hp	Cont. Amps		2	4	8	12	
D125	6	100	125	75	96	0	1.00	1.00	0.84	0.66	<p>All Enclosures</p>
						500	1.00	1.00	0.83	0.65	
						1000	1.00	1.00	0.81	0.63	
						1500	1.00	1.00	0.79	0.62	
						2000	1.00	1.00	0.77	0.60	
						2500	1.00	1.00	0.74	0.57	
						3000	1.00	1.00	0.70	0.55	
						3500	1.00	1.00	0.69	0.53	
						4000	1.00	1.00	0.66	0.50	
						4500	1.00	1.00	0.63	0.49	
4800	1.00	1.00	0.61	0.47							
D156	6	125	156	100	125	0	1.00	1.00	0.88	0.68	
						500	1.00	1.00	0.87	0.67	
						1000	1.00	1.00	0.84	0.65	
						1500	1.00	1.00	0.83	0.64	
						2000	1.00	1.00	0.80	0.62	
						2500	1.00	1.00	0.77	0.60	
						3000	1.00	1.00	0.74	0.57	
						3500	1.00	1.00	0.71	0.55	
						4000	1.00	1.00	0.69	0.53	
						4500	1.00	1.00	0.67	0.51	
4800	1.00	1.00	0.65	0.49							
D186	6	150	186	125	156	0	1.00	1.00	0.74	0.58	
						500	1.00	1.00	0.72	0.57	
						1000	1.00	1.00	0.70	0.55	
						1500	1.00	1.00	0.69	0.54	
						2000	1.00	1.00	0.67	0.53	
						2500	1.00	1.00	0.64	0.51	
						3000	1.00	1.00	0.62	0.48	
						3500	1.00	0.96	0.60	0.46	
						4000	1.00	0.94	0.57	0.44	
						4500	1.00	0.91	0.56	0.44	
4800	1.00	0.89	0.54	0.43							

### Altitude Derating Curves—480V AC Frames 1..7 (Continued)

Cat. No. 206...	Frame	480V AC Power Rating				Altitude/Load Derating								
		ND		HD		Altitude m	PWM Frequency kHz				Altitude/Load			
		Hp	Cont. Amps	Hp	Cont. Amps		2	4	8	12				
D248	6	200	248	150	186	0	1.00	0.76	0.54	0.41				
						500	1.00	0.74	0.53	0.40				
						1000	0.98	0.72	0.52	0.39				
						1500	0.95	0.70	0.50	0.37				
						2000	0.93	0.68	0.49	0.36				
						2500	0.89	0.66	0.47	0.35				
						3000	0.85	0.62	0.44	0.33				
						3500	0.82	0.59	0.42	0.31				
						4000	0.79	0.56	0.40	0.29				
						4500	0.76	0.53	0.39	0.28				
						4800	0.74	0.52	0.38	0.27				
D302	7	250	302	200	248	0	1.00	0.89	0.59	—				
						500	1.00	0.88	0.58	—				
						1000	1.00	0.85	0.56	—				
						1500	1.00	0.83	0.54	—				
						2000	1.00	0.79	0.52	—				
						2500	1.00	0.75	0.49	—				
						3000	1.00	0.73	0.47	—				
						3500	0.95	0.69	0.45	—				
						4000	0.92	0.65	0.43	—				
						4500	0.88	0.63	0.41	—				
						4800	0.85	0.62	0.39	—				
D361	7	300	361	250	302	0	1.00	0.74	0.49	—				
						500	0.99	0.74	0.48	—				
						1000	0.95	0.71	0.47	—				
						1500	0.93	0.69	0.45	—				
						2000	0.90	0.67	0.43	—				
						2500	0.86	0.64	0.41	—				
						3000	0.83	0.59	0.39	—				
						3500	0.80	0.57	0.37	—				
						4000	0.75	0.54	0.35	—				
						4500	0.72	0.53	0.34	—				
						4800	0.70	0.52	0.33	—				

**Altitude Derating Curves—480V AC Frames 1..7 (Continued)**

Cat. No. 206...	Frame	480V AC Power Rating				Altitude/Load Derating					
		ND		HD		Altitude m	PWM Frequency kHz				Altitude/Load
		Hp	Cont. Amps	Hp	Cont. Amps		2	4	8	12	
All Enclosures 											
D415	7	350	415	300	361	0	1.00	0.83	0.58	—	
						500	1.00	0.79	0.57	—	
						1000	0.99	0.78	0.55	—	
						1500	0.95	0.76	0.53	—	
						2000	0.93	0.73	0.51	—	
						2500	0.89	0.68	0.49	—	
						3000	0.84	0.65	0.46	—	
						3500	0.81	0.62	0.44	—	
						4000	0.79	0.60	0.41	—	
						4500	0.76	0.58	0.40	—	
						4800	0.74	0.57	0.39	—	
D477	7	400	477	300	361	0	1.00	0.72	0.48	—	
						500	1.00	0.68	0.47	—	
						1000	0.99	0.68	0.46	—	
						1500	0.95	0.66	0.44	—	
						2000	0.93	0.63	0.43	—	
						2500	0.89	0.59	0.40	—	
						3000	0.84	0.57	0.38	—	
						3500	0.81	0.54	0.36	—	
						4000	0.79	0.52	0.35	—	
						4500	0.76	0.50	0.33	—	
						4800	0.74	0.50	0.31	—	

# Altitude Derating—600V

The following graphs show the altitude deratings for 600V PowerFlex 755TS products specified at the rated 60 Hz output fundamental frequency and the maximum rated ambient temperature.

## Altitude Derating Curves—600V AC Frames 3...7

Cat. No. 206...	Frame	600V AC Power Rating				Altitude/Load Derating					
		ND		HD		Altitude m	PWM Frequency kHz				Altitude/Load
		Hp	Cont. Amps	Hp	Cont. Amps		2	4	8	12	
<p style="text-align: center;">All Enclosures</p> <p style="text-align: center;"> <span style="color: blue;">—</span> 2 kHz    <span style="color: orange;">—</span> 8 kHz  <span style="color: red;">—</span> 4 kHz    <span style="color: green;">—</span> 12 kHz                 </p>											
E1P7	3	1	1.7	0.5	0.9	0	1.00	1.00	1.00	—	
						500	1.00	1.00	1.00	—	
						1000	1.00	1.00	1.00	—	
						1500	1.00	1.00	1.00	—	
						2000	1.00	1.00	1.00	—	
						2500	1.00	1.00	1.00	—	
						3000	1.00	1.00	1.00	—	
						3500	1.00	1.00	1.00	—	
						4000	1.00	1.00	1.00	—	
						4500	1.00	1.00	1.00	—	
4800	1.00	1.00	1.00	—							
E2P7	3	2	2.7	1	1.7	0	1.00	1.00	1.00	—	
						500	1.00	1.00	1.00	—	
						1000	1.00	1.00	1.00	—	
						1500	1.00	1.00	1.00	—	
						2000	1.00	1.00	1.00	—	
						2500	1.00	1.00	1.00	—	
						3000	1.00	1.00	1.00	—	
						3500	1.00	1.00	1.00	—	
						4000	1.00	1.00	1.00	—	
						4500	1.00	1.00	1.00	—	
4800	1.00	1.00	1.00	—							

### Altitude Derating Curves—600V AC Frames 3...7 (Continued)

Cat. No. 206...	Frame	600V AC Power Rating				Altitude/Load Derating					
		ND		HD		Altitude	PWM Frequency kHz				Altitude/Load
		Hp	Cont. Amps	Hp	Cont. Amps	m	2	4	8	12	
E3P9	3	3	3.9	2	2.7	0	1.00	1.00	1.00	—	<p>All Enclosures</p>
						500	1.00	1.00	1.00	—	
						1000	1.00	1.00	1.00	—	
						1500	1.00	1.00	1.00	—	
						2000	1.00	1.00	1.00	—	
						2500	1.00	1.00	1.00	—	
						3000	1.00	1.00	1.00	—	
						3500	1.00	1.00	1.00	—	
						4000	1.00	1.00	1.00	—	
						4500	1.00	1.00	1.00	—	
4800	1.00	1.00	1.00	—							
E6P1	3	5	6.1	3	3.9	0	1.00	1.00	1.00	—	
						500	1.00	1.00	1.00	—	
						1000	1.00	1.00	1.00	—	
						1500	1.00	1.00	1.00	—	
						2000	1.00	1.00	1.00	—	
						2500	1.00	1.00	1.00	—	
						3000	1.00	1.00	1.00	—	
						3500	1.00	1.00	1.00	—	
						4000	1.00	1.00	1.00	—	
						4500	1.00	1.00	1.00	—	
4800	1.00	1.00	1.00	—							
E9P0	3	7.5	9	5	6.1	0	1.00	1.00	1.00	—	
						500	1.00	1.00	1.00	—	
						1000	1.00	1.00	1.00	—	
						1500	1.00	1.00	1.00	—	
						2000	1.00	1.00	1.00	—	
						2500	1.00	1.00	1.00	—	
						3000	1.00	1.00	1.00	—	
						3500	1.00	1.00	1.00	—	
						4000	1.00	1.00	1.00	—	
						4500	1.00	1.00	1.00	—	
4800	1.00	1.00	1.00	—							

### Altitude Derating Curves—600V AC Frames 3...7 (Continued)

Cat. No. 206...	Frame	600V AC Power Rating				Altitude/Load Derating					
		ND		HD		Altitude	PWM Frequency kHz				Altitude/Load
		Hp	Cont. Amps	Hp	Cont. Amps	m	2	4	8	12	
E011	3	10	11	7.5	9	0	1.00	1.00	1.00	—	<p>All Enclosures</p>
						500	1.00	1.00	1.00	—	
						1000	1.00	1.00	1.00	—	
						1500	1.00	1.00	1.00	—	
						2000	1.00	1.00	1.00	—	
						2500	1.00	1.00	1.00	—	
						3000	1.00	1.00	1.00	—	
						3500	1.00	1.00	1.00	—	
						4000	1.00	1.00	1.00	—	
						4500	1.00	1.00	0.98	—	
4800	1.00	1.00	0.95	—							
E012	6	10	12	7.5	9.1	0	1.00	1.00	—	—	
						500	1.00	1.00	—	—	
						1000	1.00	1.00	—	—	
						1500	1.00	1.00	—	—	
						2000	1.00	1.00	—	—	
						2500	1.00	1.00	—	—	
						3000	1.00	1.00	—	—	
						3500	1.00	1.00	—	—	
						4000	1.00	1.00	—	—	
						4500	1.00	1.00	—	—	
4800	1.00	1.00	—	—							
E017	3	15	17	10	11	0	1.00	1.00	0.89	—	
						500	1.00	1.00	0.87	—	
						1000	1.00	1.00	0.85	—	
						1500	1.00	1.00	0.83	—	
						2000	1.00	1.00	0.80	—	
						2500	1.00	1.00	0.76	—	
						3000	1.00	1.00	0.73	—	
						3500	1.00	1.00	0.70	—	
						4000	1.00	1.00	0.67	—	
						4500	1.00	1.00	0.64	—	
4800	1.00	0.97	0.61	—							

### Altitude Derating Curves—600V AC Frames 3...7 (Continued)

Cat. No. 206...	Frame	600V AC Power Rating				Altitude/Load Derating					
		ND		HD		Altitude	PWM Frequency kHz				Altitude/Load
		Hp	Cont. Amps	Hp	Cont. Amps	m	2	4	8	12	
E018	6	15	18	10	12	0	1.00	1.00	—	—	<p>All Enclosures</p>
						500	1.00	1.00	—	—	
						1000	1.00	1.00	—	—	
						1500	1.00	1.00	—	—	
						2000	1.00	1.00	—	—	
						2500	1.00	1.00	—	—	
						3000	1.00	1.00	—	—	
						3500	1.00	1.00	—	—	
						4000	1.00	1.00	—	—	
						4500	1.00	1.00	—	—	
4800	1.00	1.00	—	—							
E022	3	20	22	15	17	0	1.00	1.00	0.70	—	
						500	1.00	1.00	0.68	—	
						1000	1.00	0.97	0.66	—	
						1500	1.00	0.95	0.64	—	
						2000	1.00	0.93	0.62	—	
						2500	1.00	0.88	0.60	—	
						3000	1.00	0.85	0.57	—	
						3500	1.00	0.82	0.55	—	
						4000	1.00	0.78	0.53	—	
						4500	1.00	0.76	0.51	—	
4800	1.00	0.72	0.48	—							
E023	6	20	23	15	18	0	1.00	1.00	—	—	
						500	1.00	1.00	—	—	
						1000	1.00	1.00	—	—	
						1500	1.00	1.00	—	—	
						2000	1.00	1.00	—	—	
						2500	1.00	1.00	—	—	
						3000	1.00	1.00	—	—	
						3500	1.00	1.00	—	—	
						4000	1.00	1.00	—	—	
						4500	1.00	1.00	—	—	
4800	1.00	1.00	—	—							

### Altitude Derating Curves—600V AC Frames 3...7 (Continued)

Cat. No. 206...	Frame	600V AC Power Rating				Altitude/Load Derating					
		ND		HD		Altitude	PWM Frequency kHz				Altitude/Load
		Hp	Cont. Amps	Hp	Cont. Amps	m	2	4	8	12	
E024	6	20	24	20	22	0	1.00	1.00	—	—	<p>All Enclosures</p>
						500	1.00	1.00	—	—	
						1000	1.00	1.00	—	—	
						1500	1.00	1.00	—	—	
						2000	1.00	1.00	—	—	
						2500	1.00	1.00	—	—	
						3000	1.00	1.00	—	—	
						3500	1.00	1.00	—	—	
						4000	1.00	1.00	—	—	
						4800	1.00	1.00	—	—	
E027	4	25	27	20	22	0	1.00	1.00	0.65	—	
						500	1.00	0.98	0.63	—	
						1000	1.00	0.96	0.60	—	
						1500	1.00	0.92	0.58	—	
						2000	1.00	0.90	0.56	—	
						2500	1.00	0.84	0.53	—	
						3000	1.00	0.80	0.50	—	
						3500	0.97	0.76	0.47	—	
						4000	0.94	0.73	0.45	—	
						4500	0.90	0.70	0.43	—	
4800	0.88	0.66	0.40	—							
E028	6	25	28	20	23	0	1.00	1.00	—	—	
						500	1.00	1.00	—	—	
						1000	1.00	1.00	—	—	
						1500	1.00	1.00	—	—	
						2000	1.00	1.00	—	—	
						2500	1.00	1.00	—	—	
						3000	1.00	1.00	—	—	
						3500	1.00	1.00	—	—	
						4000	1.00	1.00	—	—	
						4500	1.00	1.00	—	—	
4800	1.00	1.00	—	—							

### Altitude Derating Curves—600V AC Frames 3...7 (Continued)

Cat. No. 206...	Frame	600V AC Power Rating				Altitude/Load Derating					
		ND		HD		Altitude	PWM Frequency kHz				Altitude/Load
		Hp	Cont. Amps	Hp	Cont. Amps	m	2	4	8	12	
E032	4	30	32	25	27	0	1.00	0.92	0.54	—	<p>All Enclosures</p>
						500	0.98	0.88	0.52	—	
						1000	0.96	0.85	0.50	—	
						1500	0.94	0.82	0.48	—	
						2000	0.92	0.79	0.47	—	
						2500	0.90	0.75	0.44	—	
						3000	0.89	0.71	0.42	—	
						3500	0.84	0.68	0.40	—	
						4000	0.80	0.65	0.38	—	
						4500	0.76	0.62	0.36	—	
4800	0.73	0.58	0.34	—							
E033	6	30	33	25	28	0	1.00	1.00	—	—	
						500	1.00	1.00	—	—	
						1000	1.00	1.00	—	—	
						1500	1.00	1.00	—	—	
						2000	1.00	1.00	—	—	
						2500	1.00	1.00	—	—	
						3000	1.00	1.00	—	—	
						3500	1.00	1.00	—	—	
						4000	1.00	1.00	—	—	
						4500	1.00	1.00	—	—	
4800	1.00	1.00	—	—							
E041	5	40	41	30	32	0	1.00	1.00	0.64	—	
						500	1.00	1.00	0.61	—	
						1000	1.00	0.97	0.59	—	
						1500	1.00	0.94	0.56	—	
						2000	1.00	0.91	0.54	—	
						2500	1.00	0.86	0.51	—	
						3000	1.00	0.82	0.48	—	
						3500	1.00	0.79	0.46	—	
						4000	1.00	0.76	0.44	—	
						4500	1.00	0.73	0.42	—	
4800	1.00	0.69	0.39	—							

### Altitude Derating Curves—600V AC Frames 3...7 (Continued)

Cat. No. 206...	Frame	600V AC Power Rating				Altitude/Load Derating					
		ND		HD		Altitude m	PWM Frequency kHz				Altitude/Load
		Hp	Cont. Amps	Hp	Cont. Amps		2	4	8	12	
E042	6	40	42	30	33	0	1.00	1.00	—	—	<p>All Enclosures</p>
						500	1.00	1.00	—	—	
						1000	1.00	1.00	—	—	
						1500	1.00	1.00	—	—	
						2000	1.00	1.00	—	—	
						2500	1.00	1.00	—	—	
						3000	1.00	1.00	—	—	
						3500	1.00	1.00	—	—	
						4000	1.00	1.00	—	—	
						4800	1.00	1.00	—	—	
E052	5	50	52	40	41	0	1.00	0.83	0.51	—	
						500	0.99	0.80	0.48	—	
						1000	0.97	0.78	0.46	—	
						1500	0.95	0.75	0.44	—	
						2000	0.93	0.73	0.43	—	
						2500	0.90	0.70	0.41	—	
						3000	0.87	0.66	0.39	—	
						3500	0.85	0.63	0.37	—	
						4000	0.83	0.60	0.35	—	
						4800	0.78	0.54	0.32	—	
E053	6	50	53	40	42	0	1.00	1.00	—	—	
						500	1.00	1.00	—	—	
						1000	1.00	1.00	—	—	
						1500	1.00	1.00	—	—	
						2000	1.00	1.00	—	—	
						2500	1.00	1.00	—	—	
						3000	1.00	1.00	—	—	
						3500	1.00	1.00	—	—	
						4000	1.00	1.00	—	—	
						4800	1.00	1.00	—	—	

**Altitude Derating Curves—600V AC Frames 3...7 (Continued)**

Cat. No. 206...	Frame	600V AC Power Rating				Altitude/Load Derating					
		ND		HD		Altitude	PWM Frequency kHz				Altitude/Load
		Hp	Cont. Amps	Hp	Cont. Amps	m	2	4	8	12	
E063	6	60	63	50	52	0	1.00	1.00	—	—	<p>All Enclosures</p>
						500	1.00	1.00	—	—	
						1000	1.00	1.00	—	—	
						1500	1.00	1.00	—	—	
						2000	1.00	1.00	—	—	
						2500	1.00	1.00	—	—	
						3000	1.00	1.00	—	—	
						3500	1.00	1.00	—	—	
						4000	1.00	1.00	—	—	
						4500	1.00	1.00	—	—	
4800	1.00	1.00	—	—							
E077	6	75	77	60	63	0	1.00	1.00	—	—	
						500	1.00	1.00	—	—	
						1000	1.00	1.00	—	—	
						1500	1.00	1.00	—	—	
						2000	1.00	1.00	—	—	
						2500	1.00	1.00	—	—	
						3000	1.00	1.00	—	—	
						3500	1.00	1.00	—	—	
						4000	1.00	0.97	—	—	
						4500	1.00	0.92	—	—	
4800	1.00	0.86	—	—							
E099	6	100	99	75	77	0	1.00	1.00	—	—	
						500	1.00	1.00	—	—	
						1000	1.00	0.99	—	—	
						1500	1.00	0.95	—	—	
						2000	1.00	0.91	—	—	
						2500	1.00	0.86	—	—	
						3000	1.00	0.82	—	—	
						3500	1.00	0.78	—	—	
						4000	1.00	0.74	—	—	
						4500	1.00	0.71	—	—	
4800	1.00	0.66	—	—							

### Altitude Derating Curves—600V AC Frames 3...7 (Continued)

Cat. No. 206...	Frame	600V AC Power Rating				Altitude/Load Derating					
		ND		HD		Altitude m	PWM Frequency kHz				Altitude/Load
		Hp	Cont. Amps	Hp	Cont. Amps		2	4	8	12	
E125	6	125	125	100	99	0	1.00	0.82	—	—	<p>All Enclosures</p>
						500	1.00	0.80	—	—	
						1000	1.00	0.77	—	—	
						1500	1.00	0.74	—	—	
						2000	1.00	0.71	—	—	
						2500	0.97	0.67	—	—	
						3000	0.93	0.63	—	—	
						3500	0.89	0.60	—	—	
						4000	0.85	0.57	—	—	
						4500	0.81	0.54	—	—	
4800	0.76	0.51	—	—							
E144	6	150	144	125	125	0	1.00	0.71	—	—	
						500	0.99	0.68	—	—	
						1000	0.96	0.66	—	—	
						1500	0.93	0.63	—	—	
						2000	0.89	0.61	—	—	
						2500	0.84	0.58	—	—	
						3000	0.80	0.54	—	—	
						3500	0.77	0.52	—	—	
						4000	0.73	0.49	—	—	
						4500	0.70	0.47	—	—	
4800	0.67	0.44	—	—							
E192	7	200	192	150	144	0	1.00	1.00	—	—	
						500	1.00	1.00	—	—	
						1000	1.00	1.00	—	—	
						1500	1.00	0.96	—	—	
						2000	1.00	0.92	—	—	
						2500	1.00	0.87	—	—	
						3000	1.00	0.83	—	—	
						3500	1.00	0.79	—	—	
						4000	1.00	0.76	—	—	
						4500	1.00	0.72	—	—	
4800	1.00	0.66	—	—							

### Altitude Derating Curves—600V AC Frames 3...7 (Continued)

Cat. No. 206...	Frame	600V AC Power Rating				Altitude/Load Derating					
		ND		HD		Altitude m	PWM Frequency kHz				Altitude/Load
		Hp	Cont. Amps	Hp	Cont. Amps		2	4	8	12	
<p style="text-align: center;">All Enclosures</p>											
E242	7	250	242	200	192	0	1.00	0.77	—	—	
						500	1.00	0.76	—	—	
						1000	1.00	0.75	—	—	
						1500	1.00	0.74	—	—	
						2000	1.00	0.73	—	—	
						2500	1.00	0.70	—	—	
						3000	0.99	0.66	—	—	
						3500	0.95	0.62	—	—	
						4000	0.91	0.59	—	—	
						4500	0.86	0.57	—	—	
4800	0.80	0.53	—	—							
E289	7	300	289	250	242	0	1.00	0.70	—	—	
						500	0.98	0.70	—	—	
						1000	0.96	0.67	—	—	
						1500	0.93	0.65	—	—	
						2000	0.90	0.63	—	—	
						2500	0.85	0.60	—	—	
						3000	0.82	0.57	—	—	
						3500	0.79	0.54	—	—	
						4000	0.76	0.51	—	—	
						4500	0.73	0.49	—	—	
4800	0.69	0.46	—	—							

# Altitude Derating—690V

The following graphs show the altitude deratings for 690V PowerFlex 755TS products specified at the rated 60 Hz output fundamental frequency and the maximum rated ambient temperature.

## Altitude Derating Curves—690V AC Frames 3...7

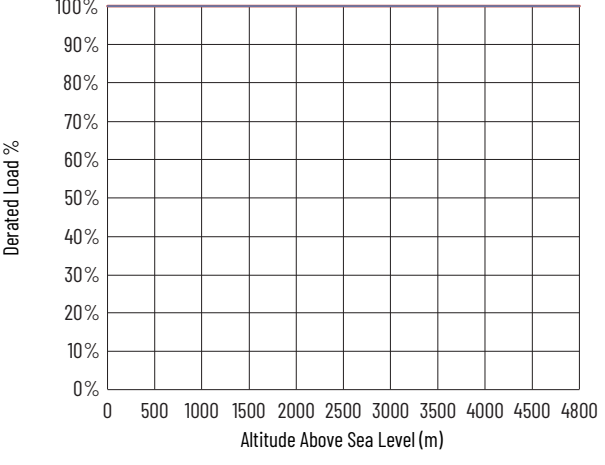
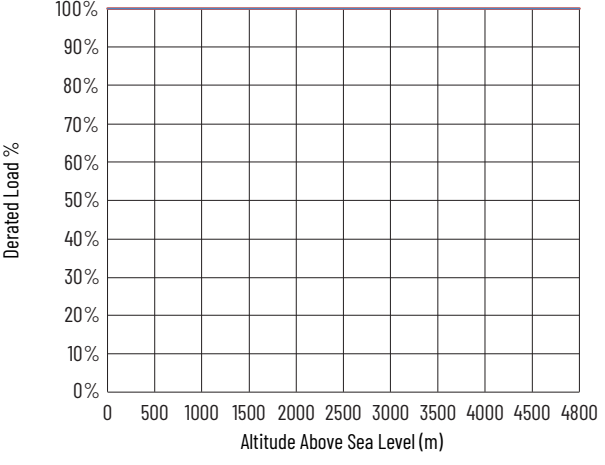
Cat. No. 206...	Frame	690V AC Power Rating				Altitude/Load Derating					
		ND		HD		Altitude m	PWM Frequency kHz				Altitude/Load
		kW	Cont. Amps	kW	Cont. Amps		2	4	8	12	
F012	6	7.5	12	5.5	9	0	1.00	1.00	—	—	<p>All Enclosures</p> <p>— 2 kHz    — 8 kHz — 4 kHz    — 12 kHz</p> 
						500	1.00	1.00	—	—	
						1000	1.00	1.00	—	—	
						1500	1.00	1.00	—	—	
						2000	1.00	1.00	—	—	
						2500	1.00	1.00	—	—	
						3000	1.00	1.00	—	—	
						3500	1.00	1.00	—	—	
						4000	1.00	1.00	—	—	
						4500	1.00	1.00	—	—	
4800	1.00	1.00	—	—							
F015	6	11	15	7.5	9	0	1.00	1.00	—	—	
						500	1.00	1.00	—	—	
						1000	1.00	1.00	—	—	
						1500	1.00	1.00	—	—	
						2000	1.00	1.00	—	—	
						2500	1.00	1.00	—	—	
						3000	1.00	1.00	—	—	
						3500	1.00	1.00	—	—	
						4000	1.00	1.00	—	—	
						4500	1.00	1.00	—	—	
4800	1.00	1.00	—	—							

**Altitude Derating Curves—690V AC Frames 3...7 (Continued)**

Cat. No. 206...	Frame	690V AC Power Rating				Altitude/Load Derating					
		ND		HD		Altitude m	PWM Frequency kHz				Altitude/Load
		kW	Cont. Amps	kW	Cont. Amps		2	4	8	12	
F020	6	15	20	11	15	0	1.00	1.00	—	—	<p>All Enclosures</p>
						500	1.00	1.00	—	—	
						1000	1.00	1.00	—	—	
						1500	1.00	1.00	—	—	
						2000	1.00	1.00	—	—	
						2500	1.00	1.00	—	—	
						3000	1.00	1.00	—	—	
						3500	1.00	1.00	—	—	
						4000	1.00	1.00	—	—	
						4800	1.00	1.00	—	—	
F023	6	18.5	23	15	20	0	1.00	1.00	—	—	
						500	1.00	1.00	—	—	
						1000	1.00	1.00	—	—	
						1500	1.00	1.00	—	—	
						2000	1.00	1.00	—	—	
						2500	1.00	1.00	—	—	
						3000	1.00	1.00	—	—	
						3500	1.00	1.00	—	—	
						4000	1.00	1.00	—	—	
						4800	1.00	1.00	—	—	
F030	6	22	30	18.5	23	0	1.00	1.00	—	—	
						500	1.00	1.00	—	—	
						1000	1.00	1.00	—	—	
						1500	1.00	1.00	—	—	
						2000	1.00	1.00	—	—	
						2500	1.00	1.00	—	—	
						3000	1.00	1.00	—	—	
						3500	1.00	1.00	—	—	
						4000	1.00	1.00	—	—	
						4800	1.00	1.00	—	—	

### Altitude Derating Curves—690V AC Frames 3...7 (Continued)

Cat. No. 206...	Frame	690V AC Power Rating				Altitude/Load Derating					
		ND		HD		Altitude	PWM Frequency kHz				Altitude/Load
		kW	Cont. Amps	kW	Cont. Amps	m	2	4	8	12	
F034	6	30	34	22	30	0	1.00	1.00	—	—	<p>All Enclosures</p>
						500	1.00	1.00	—	—	
						1000	1.00	1.00	—	—	
						1500	1.00	1.00	—	—	
						2000	1.00	1.00	—	—	
						2500	1.00	1.00	—	—	
						3000	1.00	1.00	—	—	
						3500	1.00	1.00	—	—	
						4000	1.00	1.00	—	—	
						4500	1.00	1.00	—	—	
4800	1.00	1.00	—	—							
F046	6	37	46	30	34	0	1.00	1.00	—	—	
						500	1.00	1.00	—	—	
						1000	1.00	1.00	—	—	
						1500	1.00	1.00	—	—	
						2000	1.00	1.00	—	—	
						2500	1.00	1.00	—	—	
						3000	1.00	1.00	—	—	
						3500	1.00	1.00	—	—	
						4000	1.00	1.00	—	—	
						4500	1.00	1.00	—	—	
4800	1.00	1.00	—	—							
F050	6	45	50	37	46	0	1.00	1.00	—	—	
						500	1.00	1.00	—	—	
						1000	1.00	1.00	—	—	
						1500	1.00	1.00	—	—	
						2000	1.00	1.00	—	—	
						2500	1.00	1.00	—	—	
						3000	1.00	1.00	—	—	
						3500	1.00	1.00	—	—	
						4000	1.00	1.00	—	—	
						4500	1.00	1.00	—	—	
4800	1.00	1.00	—	—							

### Altitude Derating Curves—690V AC Frames 3...7 (Continued)

Cat. No. 206...	Frame	690V AC Power Rating				Altitude/Load Derating					
		ND		HD		Altitude m	PWM Frequency kHz				Altitude/Load
		kW	Cont. Amps	kW	Cont. Amps		2	4	8	12	
F061	6	55	61	45	50	0	1.00	1.00	—	—	<p>All Enclosures</p>
						500	1.00	1.00	—	—	
						1000	1.00	1.00	—	—	
						1500	1.00	1.00	—	—	
						2000	1.00	1.00	—	—	
						2500	1.00	1.00	—	—	
						3000	1.00	1.00	—	—	
						3500	1.00	1.00	—	—	
						4000	1.00	1.00	—	—	
						4500	1.00	1.00	—	—	
4800	1.00	0.97	—	—							
F082	6	75	82	55	61	0	1.00	1.00	—	—	
						500	1.00	1.00	—	—	
						1000	1.00	1.00	—	—	
						1500	1.00	1.00	—	—	
						2000	1.00	1.00	—	—	
						2500	1.00	0.95	—	—	
						3000	1.00	0.89	—	—	
						3500	1.00	0.84	—	—	
						4000	1.00	0.81	—	—	
						4500	1.00	0.77	—	—	
4800	1.00	0.72	—	—							
F098	6	90	98	75	82	0	1.00	0.95	—	—	
						500	1.00	0.94	—	—	
						1000	1.00	0.91	—	—	
						1500	1.00	0.88	—	—	
						2000	1.00	0.85	—	—	
						2500	1.00	0.79	—	—	
						3000	1.00	0.75	—	—	
						3500	1.00	0.71	—	—	
						4000	1.00	0.68	—	—	
						4500	1.00	0.65	—	—	
4800	1.00	0.60	—	—							

### Altitude Derating Curves—690V AC Frames 3...7 (Continued)

Cat. No. 206...	Frame	690V AC Power Rating				Altitude/Load Derating					
		ND		HD		Altitude m	PWM Frequency kHz				Altitude/Load
		kW	Cont. Amps	kW	Cont. Amps		2	4	8	12	
F119	6	110	119	90	98	0	1.00	0.78	—	—	<p>All Enclosures</p>
						500	1.00	0.77	—	—	
						1000	1.00	0.75	—	—	
						1500	1.00	0.72	—	—	
						2000	1.00	0.70	—	—	
						2500	1.00	0.65	—	—	
						3000	0.99	0.62	—	—	
						3500	0.96	0.58	—	—	
						4000	0.92	0.56	—	—	
						4500	0.88	0.53	—	—	
4800	0.86	0.50	—	—							
F142	6	132	142	110	119	0	1.00	0.66	—	—	
						500	0.98	0.65	—	—	
						1000	0.96	0.63	—	—	
						1500	0.93	0.61	—	—	
						2000	0.90	0.59	—	—	
						2500	0.85	0.55	—	—	
						3000	0.80	0.52	—	—	
						3500	0.76	0.49	—	—	
						4000	0.73	0.47	—	—	
						4500	0.70	0.45	—	—	
4800	0.65	0.42	—	—							
F171	7	160	171	132	142	0	1.00	1.00	—	—	
						500	1.00	0.98	—	—	
						1000	1.00	0.95	—	—	
						1500	1.00	0.90	—	—	
						2000	1.00	0.87	—	—	
						2500	1.00	0.81	—	—	
						3000	1.00	0.77	—	—	
						3500	1.00	0.73	—	—	
						4000	1.00	0.69	—	—	
						4500	1.00	0.66	—	—	
4800	1.00	0.61	—	—							

**Altitude Derating Curves—690V AC Frames 3...7 (Continued)**

Cat. No. 206...	Frame	690V AC Power Rating				Altitude/Load Derating					
		ND		HD		Altitude m	PWM Frequency kHz				Altitude/Load
		kW	Cont. Amps	kW	Cont. Amps		2	4	8	12	
<p style="text-align: center;">All Enclosures</p>											
F212	7	200	212	160	171	0	1.00	0.81	—	—	
						500	1.00	0.79	—	—	
						1000	1.00	0.76	—	—	
						1500	1.00	0.73	—	—	
						2000	1.00	0.71	—	—	
						2500	1.00	0.66	—	—	
						3000	1.00	0.62	—	—	
						3500	0.97	0.59	—	—	
						4000	0.94	0.56	—	—	
						4500	0.91	0.53	—	—	
4800	0.89	0.50	—	—							
F263	7	250	263	200	212	0	1.00	0.71	—	—	
						500	0.99	0.68	—	—	
						1000	0.97	0.65	—	—	
						1500	0.93	0.63	—	—	
						2000	0.90	0.61	—	—	
						2500	0.85	0.57	—	—	
						3000	0.80	0.54	—	—	
						3500	0.76	0.51	—	—	
						4000	0.73	0.49	—	—	
						4500	0.70	0.47	—	—	
4800	0.65	0.43	—	—							

## Minimum Dynamic Brake Resistance

The tables in this section show the minimum dynamic brake resistance when you use the internal dynamic braking transistor.

### Brake Resistance for 208/240V Drives

Frame	208V					240V				
	ND kW	Catalog Code	Min Resistance	Max DB Current	Max Duty Cycle	ND Hp	Catalog Code	Min Resistance	Max DB Current	Max Duty Cycle
1	0.37	B2P2	39.5	10	0.453	0.5	B2P2	39.5	10	0.453
	0.75	B4P2	39.5	10	0.453	1.0	B4P2	39.5	10	0.453
	1.5	B6P8	26.3	15	0.453	2.0	B6P8	26.3	15	0.453
	2.2	B9P6	15.8	25	0.453	3.0	B9P6	15.8	25	0.453
	4	B015	15.8	25	0.453	5.0	B015	15.8	25	0.453
2	0.37	B2P2	15.8	25	0.4844	0.5	B2P2	15.8	25	0.4844
	0.75	B4P2	15.8	25	0.4844	1.0	B4P2	15.8	25	0.4844
	1.5	B6P8	15.8	25	0.4844	2.0	B6P8	15.8	25	0.4844
	2.2	B9P6	15.8	25	0.4844	3.0	B9P6	15.8	25	0.4844
	4	B015	11.29	35	0.4844	5.0	B015	11.29	35	0.4844
	5.5	B022	11.29	35	0.5603	7.5	B022	11.29	35	0.5603
3	7.5	B028	15.8	25	0.9857	10	B028	15.8	25	0.9857
	11	B042	8.3	47.6	0.9857	15	B042	8.3	47.6	0.9857
	15	B055	7.9	50	0.9857	15	B055	7.9	50	0.9857
4	15	B054	7.9	50	0.9392	20	B054	7.9	50	0.9392
	18.2	B071	6	65.8	0.9288	18.2	B071	6	65.8	0.9288
5	18.2	B070	3.95	100	0.8279	25	B070	3.95	100	0.8279
	22	B080	3.95	100	0.8279	30	B080	3.95	100	0.8279
6	22 <sup>(1)</sup>	B080 <sup>(1)</sup>	1.65	239.4	0.912	30 <sup>(1)</sup>	B080 <sup>(1)</sup>	1.65	239.4	0.912
	30	B104	1.65	239.4	0.912	40	B104	1.65	239.4	0.912
	37	B130	1.65	239.4	0.912	50	B130	1.65	239.4	0.912
	45	B154	1.65	239.4	0.912	60	B154	1.65	239.4	0.912
	55	B192	1.65	239.4	0.912	75	B192	1.65	239.4	0.912
	66	B260	1.65	239.4	0.912	100	B260	1.65	239.4	0.912
7	66 <sup>(1)</sup>	B260 <sup>(1)</sup>	1.2	329	0.78	100 <sup>(1)</sup>	B260 <sup>(1)</sup>	1.2	329	0.78
	90	B312	1.2	329	0.78	125	B312	1.2	329	0.78
	110	B360	0.82	478.8	0.78	150	B360	0.82	478.8	0.78
	132	B477	0.82	478.8	0.78	200	B477	0.82	478.8	0.78

(1) IP54, NEMA/UL Type 12 (enclosure code 6).

## Brake Resistance for 400/480V Drives

Frame	400V					480V				
	ND kW	Catalog Code	Min Resistance	Max DB Current	Max Duty Cycle	ND Hp	Catalog Code	Min Resistance	Max DB Current	Max Duty Cycle
1	0.75	C2P1	79.0	10	0.453	1.0	D2P1	79.0	10	0.453
	1.5	C3P5	79.0	10	0.453	2.0	D3P4	79.0	10	0.453
	2.2	C5P0	79.0	10	0.453	3.0	D5P0	79.0	10	0.453
	4	C8P7	52.7	15	0.453	5.0	D8P0	52.7	15	0.453
	5.5	C011	31.6	25	0.453	7.5	D011	31.6	25	0.453
	7.5	C015	31.6	25	0.453	10	D014	31.6	25	0.453
2	0.75	C2P1	31.6	25	0.4844	1.0	D2P1	31.6	25	0.4844
	1.5	C3P5	31.6	25	0.4844	2.0	D3P4	31.6	25	0.4844
	2.2	C5P0	31.6	25	0.4844	3.0	D5P0	31.6	25	0.4844
	4	C8P7	31.6	25	0.4844	5.0	D8P0	31.6	25	0.4844
	5.5	C011	31.6	25	0.4844	7.5	D011	31.6	25	0.4844
	7.5	C015	31.6	25	0.4844	10	D014	31.6	25	0.4844
	11	C022	22.6	34.9	0.5603	15	D022	22.6	34.9	0.5603
3	15	C030	31.6	25	0.9857	20	D027	31.6	25	0.9857
	18.5	C037	31.6	25	0.9857	25	D034	31.6	25	0.9857
	22	C043	16.6	47.6	0.9857	30	D040	16.6	47.6	0.9857
	30 <sup>(1)</sup>	C061 <sup>(1)</sup>	15.8	50	0.9857	40 <sup>(1)</sup>	D053 <sup>(1)</sup>	15.8	50	0.9857
4	30	C060	15.8	50	0.9392	40	D052	15.8	50	0.9392
	37	C072	15.8	50	0.9392	50	D065	15.8	50	0.9392
	37 <sup>(2)</sup>	C073 <sup>(2)</sup>	12	65.8	0.9392	50 <sup>(2)</sup>	D066 <sup>(2)</sup>	12	65.8	0.9392
	45	C086	12	65.8	0.9288	60	D078	12	65.8	0.9288
5	37 <sup>(2)</sup>	C075 <sup>(2)</sup>	7.9	100	0.8279	50 <sup>(2)</sup>	D065 <sup>(2)</sup>	7.9	100	0.8279
	45	C085	7.9	100	0.8279	60	D077	7.9	100	0.8279
	55	C104	7.9	100	0.8279	75	D096	7.9	100	0.8279
6	55 <sup>(2)</sup>	C104 <sup>(2)</sup>	3.3	239.4	0.912	75 <sup>(2)</sup>	D096 <sup>(2)</sup>	3.3	239.4	0.912
	75	C140	3.3	239.4	0.912	100	D125	3.3	239.4	0.912
	90	C170	3.3	239.4	0.912	125	D156	3.3	239.4	0.912
	110	C205	3.3	239.4	0.912	150	D186	3.3	239.4	0.912
	132	C260	3.3	239.4	0.912	200	D248	3.3	239.4	0.912
7	132 <sup>(2)</sup>	C260 <sup>(2)</sup>	2.4	329	0.78	200 <sup>(2)</sup>	D248 <sup>(2)</sup>	2.4	329	0.78
	160	C302	2.4	329	0.78	250	D302	2.4	329	0.78
	200	C367	2.4	329	0.78	300	D361	2.4	329	0.78
	250	C456	1.65	478.8	0.78	350	D415	1.65	478.8	0.78
	270	C477	1.65	478.8	0.78	400	D477	1.65	478.8	0.78

(1) IP20/IP00, NEMA/UL Open Type (enclosure code N).

(2) IP54, NEMA/UL Type 12 (enclosure code G).

### Brake Resistance for 600V Drives (Frames 3...5)

Frame	600V				
	ND Hp	Catalog Code	Min Resistance	Max DB Current	Max Duty Cycle
3	1.0	E1P7	92	11	0.5135
	2.0	E2P7	92	11	0.5135
	3.0	E3P9	92	11	0.5135
	5.0	E6P1	32	30	0.5135
	7.5	E9P0	32	30	0.5135
	10	E011	32	30	0.5135
	15	E017	32	30	0.5135
	20	E022	32	30	0.5135
4	25	E027	32	30	0.8171
	30	E032	32	30	0.8171
5	40	E041	13.5	71	0.5514
	50	E052	13.5	71	0.5514

### Brake Resistance for 600/690V Drives (Frames 6 and 7)

Frame	600V					690V				
	ND Hp	Catalog Code	Min Resistance	Max DB Current	Max Duty Cycle	ND kW	Catalog Code	Min Resistance	Max DB Current	Max Duty Cycle
6	10	E012	14.4	76.4	0.55	7.5	F012	14.4	76.4	0.55
	15	E018	14.4	76.4	0.55	11	F015	14.4	76.4	0.55
	20	E023	14.4	76.4	0.55	15	F020	14.4	76.4	0.55
	20	E024	14.4	76.4	0.55	18.5	F023	14.4	76.4	0.55
	25	E028	14.4	76.4	0.55	22	F030	14.4	76.4	0.55
	30	E033	14.4	76.4	0.55	30	F034	14.4	76.4	0.55
	40	E042	14.4	76.4	0.55	37	F046	14.4	76.4	0.55
	50	E053	14.4	76.4	0.55	45	F050	14.4	76.4	0.55
	60	E063	5.5	200	0.55	55	F061	5.5	200	0.55
	75	E077	5.5	200	0.55	75	F082	5.5	200	0.55
	100	E099	5.5	200	0.55	90	F098	5.5	200	0.55
	125	E125	5.5	200	0.55	110	F119	5.5	200	0.55
	150	E144	5.5	200	0.55	132	F142	5.5	200	0.55
7	200	E192	3.8	289	0.58	160	F171	3.8	289	0.58
	250	E242	3.8	289	0.58	200	F212	3.8	289	0.58
	300	E289	3.2	344	0.58	250	F263	3.2	344	0.58

---

## Fuse and Circuit Breaker Ratings

The tables in this section provide recommended AC line input fuse and circuit breaker information. See the following Fuses and Circuit Breakers sections for CE and UL requirements. The size recommendations are based on 40 °C (104 °F) and the U.S. NEC. Other country, state, or local codes can require different ratings. DC link fuse recommendations for DC input drives are also provided.

### Fuses

The recommended fuse types are listed here. Select a fuse rating within the range that is specified in the following tables.

- CE – Type gG fuses
- UL – Fast-acting Class J, T

---

**IMPORTANT** For maximum protection of the drive and its internal components, we recommend the use of fuses over other methods of circuit protection. Fuses reduce the risk of drive damage from power quality events and improves machine and process utilization.

---

### Circuit Breakers

The non-fuse listings in the following tables include inverse time circuit breakers, and 140M/140MT self-protected combination motor controllers. If one of these methods is chosen for protection, the following requirements apply, for both UL and CE installations:

- 140M/140MT self-protected combination motor controllers are acceptable if the installation conforms with the requirements that are specified in the tables.
- Inverse time circuit breakers shall only be used with a fuse that is specified in the tables.

208V AC Input Protection Devices—Drive Frames 1...7

Applied Rating (1)	Frame (2)	Sized For Normal Duty				Sized For Heavy Duty				Input Quantities				AC Input Protection Devices				
		Cont. Output Amps		Output Overload Amps		Cat. No.	Output Overload Amps		Cat. No.	Cont. AC Input	kVA	Amps	Fuse		Circuit Breaker (6)		140M/140MT Type E Combination Motor Controller with Adjustable Current Range (7) (8)	Min Enclosure Volume [in. <sup>3</sup> ] (n)
		Cont. Output Amps	Output Overload Amps	1 Min	3 s		1 Min	3 s					Max [A]	Min. Encl. Vol. [in. <sup>3</sup> ]	Max [A] (6)	Cat. No.		
<b>208V AC Input</b>																		
0.37	1	2.5	206...B2P2	2.8	3.8	206...B2P2	2.8	3.8	0.8	2.3	2.3	3	5	15	—	M-xxx-B25 (9)	3441	
0.75	1	4.8	206...B4P2	5.3	7.2	206...B4P2	5.3	7.2	0.8	2.3	2.3	3	5	15	—	M-xxx-B25 (9)	3441	
1.5	1	7.8	206...B6P8	8.6	11.7	206...B6P8	8.6	11.7	1.5	4.3	4.3	6	10	20	—	M-xxx-B63 (9)	3441	
2.2	1	11	206...B8P6	12.1	16.5	206...B8P6	12.1	16.5	2.6	7.1	7.1	9	20	30	—	M-xxx-C10 (9)	3441	
4.0	1	15.3	206...B015	16.9	23	206...B022 (3)	16.9	23	3.6	10.0	10.0	12	20	40	—	M-xxx-C16 (10)	3441	
0.37	2	2.5	206...B2P2	3.8	4.5	206...B2P2	3.8	4.5	0.8	2.3	2.3	3	5	15	—	M-xxx-B25 (9)	3441	
0.75	2	4.8	206...B4P2	7.2	8.6	206...B4P2	7.2	8.6	1.5	4.3	4.3	6	10	20	—	M-xxx-B63 (9)	3441	
1.5	2	7.8	206...B6P8	11.7	14	206...B6P8	11.7	14	2.6	7.1	7.1	9	15	30	—	M-xxx-C10 (9)	3441	
2.2	2	11	206...B8P6	16.5	19.8	206...B8P6	16.5	19.8	3.6	10.0	10.0	12	20	40	—	M-xxx-C16 (10)	3441	
4.0	2	17.5	206...B015	19.3	26.3	206...B022	16.9	23.0	3.6	10.0	10.0	12	25	40	—	M-xxx-C16 (10)	3441	
5.5	2	22	206...B022	24.2	33	206...B028 (3)	24.2	33.0	5.7	15.9	15.9	20	35	70	—	M-xxx-C20 (10)	3441	
7.5	3	32.2	206...B028	35.4	48.3	206...B042	35.4	48.3	7.2	19.9	19.9	25	45	80	—	M-F8E-C25	3441	
11	3	43	206...B042	47.3	64.5	206...B055	48.3	64.5	10.5	29.2	29.2	15	70	125	—	M-F8E-C32	5098	
15	4	60	206...B054	66	90	206...B070 (3)	64.5	90	14.1	39.0	39.0	50	90	150	—	M-F8E-C45	5098	
18.5	5	78.2	206...B070	86	117.3	206...B080	64.5	90	19.6	54.4	54.4	70	100	225	—	M-F8E-C45	9086	
22	6	92	206...B080	101.2	138	206...B104 (3)	90	117.3	19.6	54.4	54.4	70	100	225	—	—	—	
30	6	120	206...B104	132	180	206...B130	90	117.3	19.6	54.4	54.4	70	100	225	—	—	—	
37	6	150	206...B130	165	225	206...B154	90	117.3	19.6	54.4	54.4	70	100	225	—	—	—	
45	6	177	206...B154	194.7	265.5	206...B192	90	117.3	19.6	54.4	54.4	70	100	225	—	—	—	
55	6	221	206...B192	243.1	331.5	206...B280	90	117.3	19.6	54.4	54.4	70	100	225	—	—	—	
66	6	260	206...B260	286	390	206...B312 (3)	90	117.3	19.6	54.4	54.4	70	100	225	—	—	—	
90	7	359	206...B312	394.9	538.5	206...B360	90	117.3	19.6	54.4	54.4	70	100	225	—	—	—	
110	7	414	206...B360	455.4	621	206...B477	90	117.3	19.6	54.4	54.4	70	100	225	—	—	—	
132	7	477	206...B477	524.7	715.5		90	117.3	19.6	54.4	54.4	70	100	225	—	—	—	

- (1) Applied rating refers to the motor that is connected to the drive. For example, a B022 drive can be used in Normal Duty mode on a 5.5 kW motor, or in Heavy Duty mode on a 4 kW motor. A B028 drive can be used in Heavy Duty mode on a 5.5 kW motor with the same ratings as a B022 drive. The drive can be programmed for either mode. For any given drive catalog number, Normal Duty mode provides higher continuous current but smaller overload current when compared to Heavy Duty mode. See parameter 0:35 [Duty Rating Cfg].
- (2) Only enclosure codes F, N, and R. See the explanation of catalog number positions 8...10 for 208V drives on [page 4](#) for frame sizes of other enclosure types.
- (3) This drive is the next larger frame size.
- (4) For UL compliance - fast-acting class J (Bussmann DF-J) or fast-acting class T (Bussmann JJS) fuses only. Equivalent fuses of class J, T may be used if they have lower  $I_{peak}$  and  $I^2t$  ratings than the Bussmann JJS fuse. For CE compliance - type gR fuses (Bussmann 170M - size 00 to 3, IEC 60269 or DIN 43620, or FWP-610F, -614F, -622F) only. Minimum protection device size is the lowest rated device that supplies maximum protection without nuisance tripping. Max. source SCCR = 100 kA.
- (5) For UL compliance - fast-acting class J (Bussmann DF-J) or fast-acting class T (Bussmann JJS) fuses only. Equivalent fuses of class J, T may be used if they have lower  $I_{peak}$  and  $I^2t$  ratings than the Bussmann JJS fuse. For CE compliance - type gR fuses (Bussmann 170M - size 00 to 3, IEC 60269 or DIN 43620, or FWP-610F, -614F, -622F) only. Maximum protection device size is the highest rated device that supplies drive protection. Max. source SCCR = 100 kA.
- (6) Circuit breaker - inverse time breaker - must be used with a fuse specified in the table. For US NEC, minimum circuit breaker size is 125% of motor F.L.A. Ratings that are shown are maximum values.
- (7) Bulletin 140M/140MT with adjustable current range must have the current trip set to the maximum range so that the device does not trip.
- (8) Bulletin 140M/140MT is UL Listed for 208V Wye or Delta, and 240V Wye or Delta systems.
- (9) Bulletin 140M/140MT must be Frame C (140M-C2E-xxx or 140MT-C3E-xxx) or Frame D (140M-D8E-xxx or 140MT-D9E-xxx). Max. source SCCR = 65 kA.
- (10) Bulletin 140M/140MT must be Frame E (140M-E8E-xxx or 140MT-E9E-xxx) or Frame F (140M-F8E-xxx). Max. source SCCR = 65 kA.
- (11) When using the Bulletin 140M/140MT, the drive must be installed in a ventilated or non-ventilated enclosure with the minimum volume that is specified in this column. Application-specific thermal considerations can require a larger enclosure.

240 Volt AC Input Protection Devices—Drive Frames 1...7

Applied Rating (1)	Frame (2)	Sized For Normal Duty				Sized For Heavy Duty				Input Quantities				AC Input Protection Devices			
		Cont. Output Amps		Output Overload Amps		Cat. No.	Output Overload Amps		Cat. No.	Cont. AC Input kVA	Amps	Fuse Max [A] (6)	Circuit Breaker (8)		140M/140MT Type E Combination Motor Controller with Adjustable Current Range (7) (8)		
		1 Min	3 s	1 Min	3 s		Max [A]	Min. Encl. Vol. [in. <sup>3</sup> ]					Cat. No.	Min Enclosure Volume [in. <sup>3</sup> (n)]			
<b>240 Volt AC Input</b>																	
0.5	1	2.2	206...B2P2	2.4	3.3	206...B2P2	4.6	6.3	0.8	2.0	3	4	15	—	M-xxx-B25 (9)	3441	
							7.5	10.2	0.8	2.0	3	10	15	—	M-xxx-B25 (9)	3441	
1.0	1	4.2	206...B4P2	4.6	6.3	206...B4P2	10.6	14.4	1.6	3.8	5	10	20	—	M-xxx-B63 (9)	3441	
									1.6	3.8	5	15	20	—	M-xxx-B63 (9)	3441	
2.0	1	6.8	206...B6P8	7.5	10.2	206...B6P8	16.8	23	2.5	6.1	8	10	30	—	M-xxx-C10 (9)	3441	
									2.5	6.1	8	25	30	—	M-xxx-C10 (9)	3441	
3.0	1	9.6	206...B8P6	10.6	14.4	206...B8P6	16.9	23	3.6	8.7	12	20	40	—	M-xxx-C16 (10)	3441	
									3.6	8.7	12	25	40	—	M-xxx-C16 (10)	3441	
5.0	1	15.3	206...B015	16.8	23	206...B022 (3)	24.2	33	5.6	13.5	20	30	60	—	M-xxx-C16 (10)	3441	
0.5	2	2.2	206...B2P2	3.3	4.0	206...B2P2	3.3	4.0	0.8	2.0	3	4	15	—	M-xxx-B25 (9)	3441	
1.0	2	4.2	206...B4P2	6.3	7.6	206...B4P2	6.3	7.6	1.6	3.8	5	10	20	—	M-xxx-B63 (9)	3441	
2.0	2	6.8	206...B6P8	10.2	12.2	206...B6P8	10.2	12.2	2.5	6.1	8	10	30	—	M-xxx-C10 (9)	3441	
3.0	2	9.6	206...B8P6	14.4	17.3	206...B8P6	14.4	17.3	3.6	8.7	12	20	40	—	M-xxx-C16 (10)	3441	
5.0	2	15.3	206...B015	16.8	23	206...B022	24.2	33	5.6	13.5	20	30	70	—	M-xxx-C20 (10)	3441	
7.5	2	22	206...B022	24.2	33	206...B022	24.2	33	8.3	19.9	25	45	80	—	M-F8E-C25	3441	
	3								8.3	19.9	25	45	80	—	M-F8E-C25	5098	
10	3	28	206...B028	30.8	42	206...B042	46.2	63	10.5	25.3	35	60	125	—	M-F8E-C32	5098	
15	3	42	206...B042	46.2	63	206...B055	63	81	15.8	37.9	50	80	150	—	M-F8E-C45	5098	
	4								15.8	37.9	50	80	150	—	M-F8E-C45	9086	
20	4	54	206...B054	59.4	81	206...B070 (3)	81	105	20.3	48.8	70	100	225	—	—	—	
	3	55	206...B055	60.5	82.5	206...B071	81	105	20.3	48.8	70	100	225	—	—	—	
25	4	71	206...B071	77	105	206...B080	105	126	20.7	49.7	70	100	225	—	—	—	
30	4	80	206...B080	88	120	206...B104 (3)	120	166	26.6	64.1	80	125	300	—	—	—	
40	6	104	206...B104	114.4	156	206...B130	156	195	30.0	72.2	90	150	350	—	—	—	
50	6	130	206...B130	143	195	206...B154	195	234	39.9	96.1	125	200	350	—	—	—	
60	6	154	206...B154	169.4	231	206...B192	231	288	50.0	120.2	150	250	450	—	—	—	
75	6	192	206...B192	211.2	288	206...B260	288	390	58.2	142.3	175	300	500	—	—	—	
100	6	260	206...B260	286	390	206...B312 (3)	390	468	73.8	177.5	225	400	600	—	—	—	
									98.9	240.3	300	500	700	—	—	—	

240 Volt AC Input Protection Devices—Drive Frames 1...7 (Continued)

Applied Rating (1)	Frame (2)	Sized For Normal Duty			Sized For Heavy Duty			Input Quantities				AC Input Protection Devices					
		Cont. Output Amps		Cat. No.	Output Overload Amps		Cat. No.	1 Min	3 s	kVA	Amps	Cont. AC Input	Fuse		Circuit Breaker (6)		140M/140MT Type E Combination Motor Controller with Adjustable Current Range (7) (8)
		1 Min	3 s		Min [A] (4)	Max [A] (6)							Max [A]	Min. Encl. Vol. [in. 3] (11)	Cat. No.	Min Enclosure Volume [in. 3] (11)	
<b>240 Volt AC Input</b>																	
125	7	206...B372	343.2	468	206...B360	468	561.6	119.9	288.4	400	600	1000	—	—	—	—	
	7				206...B477	468	561.6	138.4	332.9	450	600	1000	—	—	—	—	
150	7	206...B360	396	540				138.3	332.7	450	600	1200	—	—	—	—	
200	7	206...B477	524.7	715.5				183.3	440.9	600	800	1200	—	—	—	—	

(1) Applied rating refers to the motor that is connected to the drive. For example, a B022 drive can be used in Normal Duty mode on a 7.5 Hp motor, or in Heavy Duty mode on a 5 Hp motor. A B028 drive can be used in Heavy Duty mode on a 7.5 Hp motor with the same ratings as a B022 drive. The drive can be programmed for either mode. For any given drive catalog number, Normal Duty mode provides higher continuous current but smaller overload current when compared to Heavy Duty mode. See parameter 0:35 (Duty Rating Cfg).

(2) Only enclosure codes F, N, and R. See the explanation of catalog number positions 8...10 for 240V drives on [page 4](#) for frame sizes of other enclosure types.

(3) This drive is the next larger frame size.

(4) For UL compliance - fast-acting class J (Bussmann JJS) fuses only. Equivalent fuses of class J, T may be used if they have lower I<sub>peak</sub> and I<sup>2</sup>t ratings than the Bussmann JJS fuse. For CE compliance - type gR fuses (Bussmann T70M - size 00 to 3, IEC 60269 or DIN 43620, or FWP\_G10F\_G14F\_G22F) only. Minimum protection device size is the lowest rated device that supplies maximum protection without nuisance tripping. Max. source SCCR = 100 kA.

(5) For UL compliance - fast-acting class J (Bussmann DF-J) or fast-acting class T (Bussmann JJS) fuses only. Equivalent fuses of class J, T may be used if they have lower I<sub>peak</sub> and I<sup>2</sup>t ratings than the Bussmann JJS fuse. For CE compliance - type gR fuses (Bussmann T70M - size 00 to 3, IEC 60269 or DIN 43620, or FWP\_G10F\_G14F\_G22F) only. Maximum protection device size is the highest rated device that supplies drive protection. Max. source SCCR = 100 kA.

(6) Circuit breaker - inverse time breaker - must be used with a fuse specified in the table. For US NEC, minimum circuit breaker size is 125% of motor F.L.A. Ratings that are shown are maximum values.

(7) Bulletin 140M/140MT with adjustable current range must have the current trip set to the maximum range so that the device does not trip.

(8) Bulletin 140M/140MT is UL Listed for 208V Wye or Delta, and 240V Wye or Delta systems.

(9) Bulletin 140M/140MT must be Frame C (140M-C2E-xxx or 140MT-C3E-xxx) or Frame D (140M-D8E-xxx or 140MT-D9E-xxx). Max. source SCCR = 65 kA.

(10) Bulletin 140M/140MT must be Frame D (140M-D8E-xxx or 140MT-D9E-xxx) or Frame F (140M-F8E-xxx). Max. source SCCR = 65 kA.

(11) When using the Bulletin 140M/140MT, the drive must be installed in a ventilated or non-ventilated enclosure with the minimum volume that is specified in this column. Application-specific thermal considerations can require a larger enclosure.

400V AC and 540V DC Input Protection Devices—Drive Frames 1..7

Applied Rating <sup>(1)</sup>	Frame <sup>(2)</sup>	Sized For Normal Duty		Sized For Heavy Duty		Input Quantities		AC Input Protection Devices				Input Quantities		DC Input Protection <sup>(12)</sup>					
		Cont. Output Amps	Output Overload Amps		Cat. No.	Output Overload Amps	Cont. AC Input	Fuse	Circuit Breaker <sup>(6)</sup>		T40M/T40MT Type E Combination Motor Controller with Adjustable Current Range <sup>(7)(8)</sup>	Cont. DC Input	Fuse Cat. No. 20-750-...	Fuse Holder Cat. No. 20-750-...					
			1 Min	3 s					1 Min	3 s					Min. Encl. Vol. [in. <sup>3</sup> ]	Max [A]	Min [A] <sup>(4)</sup>	Max [A] <sup>(6)</sup>	Min. Encl. Volume [in. <sup>3</sup> ] <sup>(m)</sup>
<b>400V AC Input</b>																			
0.37	1	1.3				206...C2P1	2.3	3.2	0.8	1.2	2	4	15	—	M-xxx-B25 <sup>(9)</sup>	3242	1.4	DCFUSE1-10A	DCFH-51
0.75	1	2.1	206...C2P1	2.3	3.2	206...C3P5	3.9	5.3	1.3	1.9	3	6	15	—	M-xxx-B25 <sup>(9)</sup>	3242	2.2	DCFUSE1-10A	DCFH-51
1.5	1	3.5	206...C3P5	3.9	5.3	206...C5P0	5.5	7.5	2.1	3.1	4	10	15	—	M-xxx-B40 <sup>(9)</sup>	3242	3.7	DCFUSE1-10A	DCFH-51
2.2	1	5.0	206...C5P0	5.5	7.5				3.1	4.5	6	10	20	—	M-xxx-B63 <sup>(9)</sup>	3242	5.3	DCFUSE1-10A	DCFH-51
4.0	1	8.7	206...C8P7	9.6	13.1	206...C011	13.1	17.3	3.1	4.5	6	15	20	—	M-xxx-B63 <sup>(9)</sup>	3242	5.3	DCFUSE1-10A	DCFH-51
5.5	1	11.5	206...C011	12.7	17.3	206...C015	17.3	23.1	7.1	10.3	15	25	45	—	M-xxx-C10 <sup>(9)</sup>	3242	9.2	DCFUSE1-16A	DCFH-51
7.5	1	15.4	206...C015	16.9	23.1				9.6	13.8	20	30	60	—	M-xxx-C16 <sup>(10)</sup>	3242	12.2	DCFUSE1-20A	DCFH-51
0.75	2	2.1	206...C2P1	3.1	3.7	206...C2P1	3.1	3.7	1.3	1.9	3	4	15	—	M-xxx-B25 <sup>(9)</sup>	3242	2.2	DCFUSE1-10A	DCFH-51
1.5	2	3.5	206...C3P5	5.2	6.3	206...C3P5	5.2	6.3	2.1	3.1	4	7	15	—	M-xxx-B40 <sup>(9)</sup>	3242	3.7	DCFUSE1-10A	DCFH-51
2.2	2	5.0	206...C5P0	7.5	9.0	206...C5P0	7.5	9.0	3.1	4.5	6	10	20	—	M-xxx-B63 <sup>(9)</sup>	3242	5.3	DCFUSE1-10A	DCFH-51
4.0	2	8.7	206...C8P7	13.0	15.6	206...C8P7	13.0	15.6	5.4	7.8	10	15	30	—	M-xxx-C10 <sup>(10)</sup>	3242	9.2	DCFUSE1-16A	DCFH-51
5.5	2	11.5	206...C011	17.2	20.7	206...C011	17.2	20.7	7.1	10.3	15	20	45	—	M-xxx-C16 <sup>(10)</sup>	3242	12.2	DCFUSE1-20A	DCFH-51
7.5	2	15.4	206...C015	16.9	23.1	206...C015	17.3	23.1	7.1	10.3	15	20	45	—	M-xxx-C16 <sup>(10)</sup>	3242	12.2	DCFUSE1-20A	DCFH-51
11	2	22	206...C022	24.2	33.0	206...C022	24.3	33.0	9.6	13.8	20	30	60	—	M-xxx-C20 <sup>(10)</sup>	3242	16.3	DCFUSE1-25A	DCFH-51
15	3	30	206...C030	33.0	45.0	206...C030	33.0	45.0	13.6	19.7	25	45	80	—	M-F8E-C25	3242	23.2	DCFUSE1-40A	DCFH-NH1
18.5	3	37	206...C037	40.7	55.5	206...C037	46.0	55.5	18.6	26.9	35	60	100	—	M-F8E-C25	4052	23.2	DCFUSE1-40A	DCFH-NH1
22	3	43	206...C043	47.3	64.5	206...C043	55.5	66.6	22.9	33.1	45	70	110	—	M-F8E-C32	4052	31.7	DCFUSE3-63A	DCFH-NH1
30	4	60	206...C060	66.0	90.0	206...C060 <sup>(3)</sup>	66.0	90.0	26.7	38.5	50	90	120	—	M-F8E-C45	4052	39.1	DCFUSE3-63A	DCFH-NH1
37	5	72	206...C072	79.2	108.0	206...C072	79.2	108.0	37.2	53.7	70	100	180	—	—	—	45.4	DCFUSE3-80A	DCFH-NH1
45	5	85	206...C085	93.5	127.5	206...C085	93.5	127.5	44.6	64.4	80	125	200	—	—	—	63.4	DCFUSE3-125A	DCFH-NH1
55	5	104	206...C104	114.4	156.0	206...C104 <sup>(3)</sup>	114.4	156.0	53.3	77.0	100	150	250	—	—	—	63.4	DCFUSE3-125A	DCFH-NH1
									64.5	93.1	125	200	300	—	—	—	64.5	DCFUSE3-125A	DCFH-NH1
									64.5	93.1	125	200	300	—	—	—	109.9	DCFUSE3S-200A	DCFH-NH1

400V AC and 540V DC Input Protection Devices—Drive Frames 1...7 (Continued)

Applied Rating (1)	Frame (2)	Sized For Normal Duty		Sized For Heavy Duty		Input Quantities		AC Input Protection Devices				Input Quantities		DC Input Protection (12)		
		Cat. No.	Output Overload Amps	Cat. No.	Output Overload Amps	Cont. AC Input	Fuse	Circuit Breaker (6)	140M/140MT Type E Combination Motor Controller with Adjustable Current Range (7) (8)	Cont. DC Input	Fuse Cat. No.	Fuse Holder Cat. No.				
kW		1 Min	3 s	1 Min	3 s	kVA	Amps	Min [A] (4)	Max [A] (5)	Min. Encl. Vol. [in. 3]	Cat. No.	Min Enclosure Volume [in. 3] (11)	Amps	20-750-...	20-750-...	
<b>400V AC Input</b>																
75	6	140	206...C140	210.0	154.0	206...C170	210.0	255.0	88.9	128.3	175	300	400	—	—	DCFH-NH1
90	6	170	206...C170	187.0	187.0	206...C205	255.0	307.5	107.9	153.8	200	300	500	—	—	DCFH-NH1
110	6	205	206...C205	225.0	307.5	206...C260	307.5	390.0	130.1	187.8	250	400	600	—	—	DCFH-NH1
132	6	280	206...C260	286.0	390.0	—	—	—	165.0	238.2	300	500	700	—	—	DCFH-NH2
	7		—	—	—	206...C302	390.0	468.0	165.0	238.2	300	500	700	—	—	DCFH-NH3
160	7	302	206...C302	332.2	453.0	206...C367	453.0	550.5	191.7	276.7	350	600	900	—	—	DCFH-NH3
200	7	367	206...C367	403.5	550.5	206...C456	550.5	684.0	232.9	336.2	450	700	1100	—	—	DCFH-NH3
250	7	456	206...C456	501.6	684.0	—	—	—	232.9	336.2	450	700	1100	—	—	DCFH-NH3
270	7	477	206...C477	524.7	715.5	—	—	—	289.5	417.8	600	800	1300	—	—	DCFH-NH3
	7		—	—	—	206...C477	550.5	684.0	302.8	437.0	600	800	1300	—	—	DCFH-NH3

(1) Applied rating refers to the motor that is connected to the drive. For example, a C022 drive can be used in Normal Duty mode on a 7.5 kW motor, or in Heavy Duty mode on a 11 kW motor. A C015 drive can be used in Heavy Duty mode on a 5.5 kW motor with the same ratings as a C011 drive. The drive can be programmed for either mode. For any given drive catalog number, Normal Duty mode provides higher continuous current but smaller overload current when compared to Heavy Duty mode. See parameter 0:35 [Duty Rating Cfg].

(2) Only enclosure codes F, N, and R. See the explanation of catalog number positions 8...10 for 400V drives on [page 5](#) for frame sizes of other enclosure types.

(3) This drive is the next larger frame size.

(4) For UL compliance - fast-acting class J (Bussmann DF-J) or fast-acting class T (Bussmann JJS) fuses only. Equivalent fuses of class J, T may be used if they have lower I<sub>peak</sub> and I<sup>2</sup>t ratings than the Bussmann JJS fuse. For CE compliance - type gR fuses (Bussmann 170M - size 00 to 3, IEC 60269) or DIN 43620, or FWP-, G10F-, G14F-, G22F) only. Minimum protection device size is the lowest rated device that supplies maximum protection without nuisance tripping. Max. source SCCR = 100 kA.

(5) For UL compliance - fast-acting class J (Bussmann DF-J) or fast-acting class T (Bussmann JJS) fuses only. Equivalent fuses of class J, T may be used if they have lower I<sub>peak</sub> and I<sup>2</sup>t ratings than the Bussmann JJS fuse. For CE compliance - type gR fuses (Bussmann 170M - size 00 to 3, IEC 60269) or DIN 43620, or FWP-, G10F-, G14F-, G22F) only. Maximum protection device size is the highest rated device that supplies drive protection. Max. source SCCR = 100 kA.

(6) Circuit breaker - inverse time breaker - must be used with a fuse specified in the table. For US NEC, minimum circuit breaker size is 125% of motor F.L.A. Ratings that are shown are maximum values.

(7) Bulletin 140M/140MT with adjustable current range must have the current trip set to the maximum range so that the device does not trip.

(8) Bulletin 140M/140MT is UL Listed for 480V/277V. Not UL Listed for use on 400V or 480V Delta/Delta, corner ground, or high-resistance ground systems.

(9) Bulletin 140M/140MT must be Frame C (140M-C2E-xxx or 140MT-C3E-xxx) or Frame D (140M-D8E-xxx or 140MT-D9E-xxx). Max. source SCCR = 65 kA.

(10) Bulletin 140M/140MT must be Frame D (140M-D8E-xxx or 140MT-D9E-xxx) or Frame F (140M-F8E-xxx). Max. source SCCR = 65 kA.

(11) When using the Bulletin 140M/140MT, the drive must be installed in a ventilated or non-ventilated enclosure with the minimum volume that is specified in this column. Application-specific thermal considerations can require a larger enclosure.

(12) DC fuses specified are UL recognized and CE compliant.

480V AC and 650V DC Input Protection Devices—Drive Frames 1...7

Applied Rating (1)	Cont. Output Amps	Sized For Normal Duty		Sized For Heavy Duty		Input Quantities		AC Input Protection Devices				Input Quantities		DC Input Protection (12)		
		Cat. No.	Output Overload Amps 1 Min	3 s	Cat. No.	Output Overload Amps 1 Min	3 s	kVA	Amps	Fuse	Circuit Breaker (6)	140M/140MT Type E Combination Motor Controller with Adjustable Current Range (7)(8)	Cont. DC Input	Fuse Cat. No. 20-750-...	Fuse Holder Cat. No. 20-750-...	
Frame (3)	Cont. Output Amps	1 Min	3 s	Cat. No.	1 Min	3 s			Min [A] (4)	Max [A] (5)	Min. Encl. Vol. [in. 3]	Cat. No.	Min Enclosure Volume [in. 3] (11)	Cont. DC Input	Fuse Cat. No. 20-750-...	
<b>480V AC Input</b>																
0.5	1			206...D2P1	2.3	3.2	0.8	1.0	2	2	15	—	M-xxx-B25 (9)	3242	DC FUSE I-10A	DCFH-51
1.0	1	206...D2P1	2.3	206...D3P4	3.7	5.1	1.6	1.9	3	4	15	—	M-xxx-B25 (9)	3242	DC FUSE I-10A	DCFH-51
2.0	1	206...D3P4	3.7	206...D5P0	5.5	7.5	2.6	3.1	4	7	15	—	M-xxx-B40 (9)	3242	DC FUSE I-10A	DCFH-51
3.0	1	206...D5P0	5.5	206...D8P0	8.8	12.0	3.7	4.5	6	15	20	—	M-xxx-B63 (9)	3242	DC FUSE I-10A	DCFH-51
5.0	1	206...D8P0	8.8	206...D011	12.1	16.5	6.0	7.2	9	15	30	—	M-xxx-C10 (9)	3242	DC FUSE I-16A	DCFH-51
7.5	1	206...D011	12.1	206...D014	16.5	21.0	8.2	9.9	12	20	40	—	M-xxx-C16 (10)	3242	DC FUSE I-20A	DCFH-51
10	1	206...D014	15.4				10.5	12.6	15	30	50	—	M-xxx-C16 (10)	3242	DC FUSE I-25A	DCFH-51
1.0	2	206...D2P1	3.1	206...D2P1	3.1	3.7	1.6	1.9	3	4	15	—	M-xxx-B25 (9)	3242	DC FUSE I-10A	DCFH-51
2.0	2	206...D3P4	5.1	206...D3P4	5.1	6.1	2.6	3.1	4	7	15	—	M-xxx-B40 (9)	3242	DC FUSE I-10A	DCFH-51
3.0	2	206...D5P0	7.5	206...D5P0	7.5	9.0	3.7	4.5	6	10	20	—	M-xxx-B63 (9)	3242	DC FUSE I-10A	DCFH-51
5.0	2	206...D8P0	12.0	206...D8P0	12.0	14.4	6.0	7.2	9	15	30	—	M-xxx-C10 (10)	3242	DC FUSE I-16A	DCFH-51
7.5	2	206...D011	16.5	206...D011	16.5	19.8	8.2	9.9	12	20	40	—	M-xxx-C16 (10)	3242	DC FUSE I-20A	DCFH-51
10	2	206...D014	15.4	206...D022	21.0	33.0	10.5	12.6	15	30	50	—	M-xxx-C16 (10)	3242	DC FUSE I-20A	DCFH-51
15	2	206...D022	24.2	206...D027	33.0	40.5	16.5	19.9	25	45	80	—	M-F8E-C25	3242	DC FUSE I-25A	DCFH-NH1
20	3	206...D027	29.7	206...D034	40.5	51.0	20.3	24.4	30	50	100	—	M-F8E-C25	4052	DC FUSE I-40A	DCFH-NH1
25	3	206...D034	37.4	206...D040	51.0	61.2	25.5	30.7	40	60	100	—	M-F8E-C32	4052	DC FUSE I-50A	DCFH-NH1
30	3	206...D040	44.0	206...D053	60.0	78.0	30.0	36.1	45	80	120	—	M-F8E-C45	4052	DC FUSE I-63A	DCFH-NH1
40	4	206...D052	57.2	206...D052	60.0	78.0	30.0	36.1	45	80	120	—	M-F8E-C45	4863	DC FUSE I-70A	DCFH-NH1
50	4	206...D052	57.2	206...D065	78.0	97.5	39.1	47.0	60	100	150	—	M-F8E-C45	—	DC FUSE I-100A	DCFH-NH1
60	4	206...D052	57.2	206...D066	78.0	97.5	39.1	47.0	60	100	150	—	—	—	DC FUSE I-100A	DCFH-NH1
75	3	206...D053	58.3	206...D078	97.5	117.0	48.8	58.7	80	125	175	—	—	—	DC FUSE I-100A	DCFH-NH1
80	4	206...D065	71.5	206...D078	97.5	117.0	48.8	58.7	80	125	175	—	—	—	DC FUSE I-125A	DCFH-NH1
90	4	206...D066	72.5	206...D077	97.5	117.0	48.8	58.7	80	125	175	—	—	—	DC FUSE I-160A	DCFH-NH1
100	4	206...D077	84.7	206...D086	115.5	144.0	57.8	69.5	90	150	225	—	—	—	DC FUSE I-125A	DCFH-NH1
125	4	206...D078	85.8	206...D078	117.0	144.0	58.5	70.4	90	150	225	—	—	—	DC FUSE I-160A	DCFH-NH1
150	5	206...D086	105.6	206...D125(3)	144.0	187.5	72.1	86.7	110	200	275	—	—	—	DC FUSE I-200A	DCFH-NH1
200	6	206...D125	137.5	206...D166	187.5	234.0	96.0	115.5	150	250	375	—	—	—	DC FUSE I-250A	DCFH-NH1

480V AC and 650V DC Input Protection Devices—Drive Frames 1...7 (Continued)

Applied Rating (1)	Frame (2)	Cont. Output Amps		Sized For Normal Duty		Sized For Heavy Duty		Input Quantities		AC Input Protection Devices				DC Input Protection (12)			
		Cont. Output Amps	Cat. No.	Output Overload Amps	Cat. No.	1 Min	3 s	Output Overload Amps	Cat. No.	Cont. AC Input	Fuse	Circuit Breaker (6)	140M/140MT Type E Combination Motor Controller with Adjustable Current Range (7) (6)	Cont. DC Input	Fuse Cat. No.	Fuse Holder Cat. No.	
Hp				1 Min	3 s	1 Min	3 s	kVA	Amps	Min [A] (4)	Max [A] (5)	Min. Encl. Vol. [in. 3]	Cat. No.	Min Enclosure Volume [in. 3] (11)	20-750-...	20-750-...	
<b>480V AC Input</b>																	
125	6	156	206...D156	171.6	234.0	234.0	280.8	119.9	144.2	200	300	450	-	-	170.2	DCFUSE3S-315A	DCFH-NH1
150	6	186	206...D186	204.6	279.0	279.0	372.0	142.9	171.9	225	400	550	-	-	203.0	DCFUSE3S-400A	DCFH-NH1
200	6	248	206...D248	272.8	372.0			190.6	229.2	300	450	700	-	-	270.6	DCFUSE5S-500A	DCFH-NH2
	7																
250	7	302	206...D302	332.2	453.0	453.0	543.6	232.0	279.1	350	600	900	-	-	329.5	DCFUSE6S-550A	DCFH-NH3
300	7	361	206...D361	397.1	541.5			206...D415	277.3	333.6	450	700	1000	-	333.9	DCFUSE6S-700A	DCFH-NH3
	7																
350	7	415	206...D415	456.5	622.5			318.9	383.6	500	800	1200	-	-	452.8	DCFUSE6S-900A	DCFH-NH3
400	7	477	206...D477	524.7	715.5			366.6	440.9	600	800	1400	-	-	520.5	DCFUSE6S-900A	DCFH-NH3

- (1) Applied rating refers to the motor that is connected to the drive. For example, a D022 drive can be used in Normal Duty mode on a 15 Hp motor, or in Heavy Duty mode on a 10 Hp motor. A D014 drive can be used in Heavy Duty mode on a 7.5 Hp motor with the same ratings as a D011 drive. The drive can be programmed for either mode. For any given catalog number, Normal Duty mode provides higher continuous current but smaller overload current when compared to Heavy Duty mode. See parameter U35 [Duty Rating Cr].
- (2) Only enclosure codes F, N, and R. See the explanation of catalog number positions 8...10 for 480V drives on [page 5](#) for frame sizes of other enclosure types.
- (3) This drive is the next larger frame size.
- (4) For UL compliance - fast-acting class J (Bussmann DF-J) or fast-acting class T (Bussmann JJS) fuses only. Equivalent fuses of class J, T may be used if they have lower I<sub>peak</sub> and I<sup>2</sup>t ratings than the Bussmann JJS fuse. For CE compliance - type gR fuses (Bussmann 170M - size 00 to 3, IEC 60269 or DIN 43620, or FWP-610F, 614F, 622F) only. Minimum protection device size is the lowest rated device that supplies maximum protection without nuisance tripping. Max. source SCCR = 100 kA.
- (5) For UL compliance - fast-acting class J (Bussmann DF-J) or fast-acting class T (Bussmann JJS) fuses only. Equivalent fuses of class J, T may be used if they have lower I<sub>peak</sub> and I<sup>2</sup>t ratings than the Bussmann JJS fuse. For CE compliance - type gR fuses (Bussmann 170M - size 00 to 3, IEC 60269 or DIN 43620, or FWP-610F, 614F, 622F) only. Maximum protection device size is the highest rated device that supplies drive protection. Max. source SCCR = 100 kA.
- (6) Circuit breaker - inverse time breaker - must be used with a fuse specified in the table. For US NEC, minimum circuit breaker size is 125% of motor F.L.A. Ratings that are shown are maximum values.
- (7) Bulletin 140M/140MT with adjustable current range must have the current trip set to the maximum range so that the device does not trip.
- (8) Bulletin 140M/140MT is UL Listed for 480Y/277V. Not UL Listed for use on 400V or 480V Delta/Delta, corner ground, or high-resistance ground systems.
- (9) Bulletin 140M/140MT must be Frame C (140M-C2E-xxx or 140MT-C3E-xxx) or Frame D (140M-D8E-xxx or 140MT-D9E-xxx). Max. source SCCR = 65 kA.
- (10) Bulletin 140M/140MT must be Frame D (140M-D8E-xxx or 140MT-D9E-xxx) or Frame F (140M-F8E-xxx). Max. source SCCR = 65 kA.
- (11) When using the Bulletin 140M/140MT, the drive must be installed in a ventilated or non-ventilated enclosure with the minimum volume that is specified in this column. Application-specific thermal considerations can require a larger enclosure.
- (12) DC fuses specified are UL recognized and CE compliant.

600V AC and 810V DC Input Protection Devices—Drive Frames 1...7

Applied Rating (1)	Cont. Output Amps	Sized For Normal Duty		Sized For Heavy Duty		Input Quantities		AC Input Protection Devices				Input Quantities		DC Input Protection (11)		
		Cont. Output Amps	Output Overload Amps	1 Min	3 s	1 Min	3 s	Cont. AC Input	Fuse	Circuit Breaker (5)	140M/140MT Type E Combination Motor Controller with Adjustable Current Range (6)(7)	Cont. DC Input	Fuse Cat. No.	DC Input Protection (11)	Fuse Cat. No.	
Hp	Frame (3)	1 Min	3 s	1 Min	3 s	kVA	Amps	Min [A] (3)	Max [A] (4)	Min. Encl. Vol. [in. 3]	Cat. No.	Min Enclosure Volume [in. 3] (10)	Amps	Fuse Cat. No.	Fuse Holder Cat. No.	
<b>600V AC Input</b>																
0.5	3	0.9				2.6	0.8	1	2	3	M-xxx-B16 (8)	5098	1	DC FUSE1-10A	DCFH-51	
1.0	3	1.7	2.6	4.1	2.6	1.6	1.5	2	3	5	M-xxx-B25 (8)	5098	1.8	DC FUSE1-10A	DCFH-51	
2.0	3	2.7	3.0	4.1	5.9	2.5	2.4	3	5	8	M-xxx-B40 (8)	5098	2.9	DC FUSE1-10A	DCFH-51	
3.0	3	3.9	4.3	5.9	9.2	3.7	3.5	5	10	11	M-D8E-B63	5098	4.2	DC FUSE1-10A	DCFH-51	
5.0	3	6.1	6.7	9.2	13.5	5.7	5.5	7	15	20	M-D8E-B63	5098	6.5	DC FUSE1-16A	DCFH-51	
7.5	3	9.0	9.9	13.5	16.5	8.4	8.1	12	20	30	M-xxx-C10 (9)	5098	9.6	DC FUSE1-16A	DCFH-51	
10	3	11	12.1	16.5	25.5	10.3	9.9	15	25	40	M-xxx-C16 (9)	5098	11.7	DC FUSE1-20A	DCFH-51	
15	3	17	18.7	25.5	33.0	16.0	15.4	20	30	50	M-F8E-C20	5098	18.1	DC FUSE4E-32A	DCFH-NH1X	
20	3	22	24.2	33.0		20.7	19.9	25	45	70	M-F8E-C25	5098	23.5	DC FUSE4E-40A	DCFH-NH1X	
25	4	22	29.7	40.5	48.6	20.7	19.9	25	45	70	M-F8E-C25	9086	23.5	DC FUSE4E-40A	DCFH-NH1X	
30	4	27	29.7	40.5	48.6	25.4	24.4	35	50	80	M-F8E-C32	9086	28.8	DC FUSE4E-50A	DCFH-NH1X	
40	4	32	35.2	48.0		30.0	28.9	40	60	100	M-F8E-C32	9086	34.1	DC FUSE4E-63A	DCFH-NH1X	
50	5	32		48.0	61.5	30.0	28.9	40	60	100	M-F8E-C32	13630	34.1	DC FUSE3ES-63A	DCFH-NH1	
75	5	41	45.1	61.5	78.0	38.5	37.0	50	80	120			43.7	DC FUSE3ES-70A	DCFH-NH1	
100	5	52	57.2	78.0		48.8	47.0	60	100	150			55.4	DC FUSE3ES-90A	DCFH-NH1	
150	6	9.1		13.7	18.0	8.5	8.2	12	20	30	M-xxx-C10 (9)	13630	9.7	DC FUSE5EFS-20A	DCFH-NH2	
200	6	12	13.2	18.0	27.0	11.2	10.8	15	25	40	M-xxx-C16 (9)	13630	12.8	DC FUSE5EFS-25A	DCFH-NH2	
250	6	18	19.8	27.0	34.5	16.9	16.3	25	35	60	M-F8E-C20	13630	19.2	DC FUSE5EFS-40A	DCFH-NH2	
300	6	23	25.3	34.5	42.0	21.6	20.8	30	45	70	M-F8E-C25	13630	24.5	DC FUSE5EFS-50A	DCFH-NH2	
400	6	24	26.4	36.0		22.6	21.7	30	45	70	M-F8E-C25	13630	24.5	DC FUSE5EFS-50A	DCFH-NH2	
500	6	22		33.0	39.6	20.7	19.9	30	45	70	M-F8E-C25	13630	23.5	DC FUSE5EFS-50A	DCFH-NH2	
600	6	28	30.8	42.0	50.4	26.3	25.3	35	50	80	M-F8E-C32	13630	29.8	DC FUSE5EFS-50A	DCFH-NH2	
750	6	33	36.3	49.5	63.0	31.0	29.8	40	70	100	M-F8E-C32	13630	35.2	DC FUSE5EFS-63A	DCFH-NH2	
1000	6	42	46.2	63.0	79.5	39.4	37.9	50	80	120			44.8	DC FUSE5EFS-90A	DCFH-NH2	
1500	6	53	58.3	79.5		39.8	47.9	60	100	150			56.5	DC FUSE5EFS-100A	DCFH-NH2	
2000	6	52		78.0	94.5	39.1	47.0	60	100	150			55.4	DC FUSE5EFS-100A	DCFH-NH2	
2500	6	63	69.3	94.5	115.5	47.3	58.9	75	125	180			67.2	DC FUSE5EFS-100A	DCFH-NH2	
3000	6	77	84.7	115.5	148.5	57.8	69.5	90	150	220			82.1	DC FUSE5EFS-150A	DCFH-NH2	
4000	6	99	108.9	148.5	187.5	76.1	91.5	125	200	280			108	DC FUSE5EFS-180A	DCFH-NH2	
5000	6	125	137.5	187.5	225.0	96.0	115.5	150	250	360			136.4	DC FUSE5EFS-250A	DCFH-NH2	

600V AC and 810V DC Input Protection Devices—Drive Frames 1...7 (Continued)

Applied Rating (1)	Frame (2)	Sized For Normal Duty		Sized For Heavy Duty		Input Quantities		AC Input Protection Devices				DC Input Protection (11)				
		Cat. No.	Output Overload Amps 1 Min	3 s	Cat. No.	Output Overload Amps 1 Min	3 s	kVA	Amps	Cont. AC Input	Fuse	Circuit Breaker (5)	140M/140MT Type E Combination Motor Controller with Adjustable Current Range (6) (7)	Cont. DC Input	Fuse Cat. No. 20-750-...	Fuse Holder Cat. No. 20-750-...
<b>600V AC Input</b>																
150	6	144	206...E144	158.4	216.0	206...E182	110.7	133.1	175	250	400	—	—	157.1	DCFUSE5EFS-316A	DCFH-NH2
	7	144	—	—	—	—	110.7	133.1	175	300	400	—	—	157.1	DCFUSE6EFS-350A	DCFH-NH3
200	7	192	206...E192	211.2	288.0	206...E242	147.6	177.5	225	400	550	—	—	209.5	DCFUSE6EFS-350A	DCFH-NH3
250	7	242	206...E242	286.2	363.0	206...E289	186.0	223.7	300	450	690	—	—	264.1	DCFUSE6EFS-450A	DCFH-NH3
300	7	289	206...E289	371.9	433.5	—	222.1	267.1	350	500	800	—	—	315.3	DCFUSE6EFS-550A	DCFH-NH3

(1) Applied rating refers to the motor that is connected to the drive. For example, a E063 drive can be used in Normal Duty mode on a 60 Hp motor, or in Heavy Duty mode on a 50 Hp motor. The drive can be programmed for either mode. For any given catalog number, Normal Duty mode provides higher continuous current but smaller overload current when compared to Heavy Duty mode. See parameter 0:35 [Duty Rating Cfg].

(2) Only enclosure codes F and N. See the explanation of catalog number positions 8...10 for 600V drives on [page 6](#) for frame sizes of other enclosure types.

(3) For UL compliance - fast-acting class J (Bussmann DJ-J) or fast-acting class T (Bussmann JJS) fuses only. Equivalent fuses of class J, T may be used if they have lower I<sub>peak</sub> and I<sup>2</sup>t ratings than the Bussmann JJS fuse. For CE compliance - type gR fuses (Bussmann 170M - size 00 to 3, IEC 60269 or DIN 43620, or FWP- 610F, 614F, 622F) only. Minimum protection device size is the lowest rated device that supplies maximum protection without nuisance tripping. Max. source SCCR = 100 kA.

(4) For UL compliance - fast-acting class J (Bussmann DJ-J) or fast-acting class T (Bussmann JJS) fuses only. Equivalent fuses of class J, T may be used if they have lower I<sub>peak</sub> and I<sup>2</sup>t ratings than the Bussmann JJS fuse. For CE compliance - type gR fuses (Bussmann 170M - size 00 to 3, IEC 60269 or DIN 43620, or FWP- 610F, 614F, 622F) only. Maximum protection device size is the highest rated device that supplies drive protection. Max. source SCCR = 100 kA.

(5) Circuit breaker - inverse time breaker - must be used with a fuse specified in the table. For US NEC, minimum circuit breaker size is 125% of motor F.L.A. Ratings that are shown are maximum values.

(6) Bulletin 140M/140MT with adjustable current range must have the current trip set to the maximum range so that the device does not trip.

(7) Bulletin 140M/140MT is UL Listed for 600V/347V. Not UL Listed for use on 600V Delta/Delta, corner ground, or high-resistance ground systems.

(8) Bulletin 140M/140MT must be Frame C (140M-C2E-xxx or 140MT-C3E-xxx) or Frame D (140M-D8E-xxx or 140MT-D9E-xxx). Max. source SCCR = 30 kA.

(9) Bulletin 140M/140MT must be Frame D (140M-D8E-xxx or 140MT-D9E-xxx) or Frame F (140M-F8E-xxx). Max. source SCCR = 30 kA.

(10) When using the Bulletin 140M/140MT, the drive must be installed in a ventilated or non-ventilated enclosure with the minimum volume that is specified in this column. Application-specific thermal considerations can require a larger enclosure.

(11) DC fuses specified are UL recognized and CE compliant.

690V AC and 932V DC Input Protection Devices—Drive Frames 6 and 7

Applied Rating (1)	Frame (2)	Sized For Normal Duty				Sized For Heavy Duty				Input Quantities				AC Input Protection Devices				Input Quantities		DC Input Protection (6)	
		Cont. Output Amps		Output Overload Amps		Cat. No.		Output Overload Amps		Cont. AC Input		Fuse		Circuit Breaker (5)		Cont. DC Input	Amps	Fuse Cat. No. 20-750-...	Fuse Holder Cat. No. 20-750-...		
		1 Min	3 s	1 Min	3 s	1 Min	3 s	kVA	Amps	Min [A] (3)	Max [A] (4)	Max [A]	Min. Encl. Vol. [in. 3]								
<b>690V AC Input</b>																					
5.5	6	9			206...F012	13.5	18.0	8.4	8.1	15	20	30	—	—	9.6	DC FUSE5EFS-20A	DCFH-NH2				
7.5	6	12	206...F012	13.2	18.0	206...F015	18.0	22.5	11.2	10.8	25	40	—	—	12.8	DC FUSE5EFS-20A	DCFH-NH2				
11	6	15	206...F015	16.5	22.5	206...F020	22.5	30.0	14.0	13.5	30	50	—	—	16.0	DC FUSE5EFS-25A	DCFH-NH2				
15	6	20	206...F020	22.0	30.0	206...F023	30.0	36.0	3.7	18.0	40	60	—	—	21.3	DC FUSE5EFS-40A	DCFH-NH2				
18.5	6	23	206...F023	25.3	34.5	206...F030	34.5	45.0	21.5	20.7	45	70	—	—	24.5	DC FUSE5EFS-50A	DCFH-NH2				
22	6	30	206...F030	33.0	45.0	206...F034	45.0	54.0	28.1	27.0	60	90	—	—	31.9	DC FUSE5EFS-50A	DCFH-NH2				
30	6	34	206...F034	37.4	51.0	206...F046	51.0	69.0	31.8	30.6	70	100	—	—	36.2	DC FUSE5EFS-63A	DCFH-NH2				
37	6	46	206...F046	50.6	69.0	206...F050	69.0	82.8	43.1	41.5	90	130	—	—	48.9	DC FUSE5EFS-90A	DCFH-NH2				
45	6	50	206...F050	55.0	75.0	206...F061	75.0	91.5	46.9	45.1	100	150	—	—	53.2	DC FUSE5EFS-100A	DCFH-NH2				
55	6	61	206...F061	67.1	91.5	206...F082	91.5	123.0	57.2	55.0	125	180	—	—	64.9	DC FUSE5EFS-100A	DCFH-NH2				
75	6	82	206...F082	90.2	123.0	206...F098	123.0	147.6	76.8	73.9	150	240	—	—	87.3	DC FUSE5EFS-150A	DCFH-NH2				
90	6	98	206...F098	107.8	145.0	206...F119	145.0	178.5	91.8	88.3	175	280	—	—	104.3	DC FUSE5EFS-180A	DCFH-NH2				
110	6	119	206...F119	130.9	178.5	206...F142	178.5	214.2	114.1	109.8	225	340	—	—	129.6	DC FUSE5EFS-250A	DCFH-NH2				
132	6	142	206...F142	156.2	213.0				136.1	131.0	250	400	—	—	154.7	DC FUSE5EFS-315A	DCFH-NH2				
160	7	171	206...F171	188.1	256.5	206...F212	256.5	318.0	163.9	157.7	300	400	—	—	154.7	DC FUSE5EFS-350A	DCFH-NH3				
200	7	212	206...F212	233.2	318.0	206...F263	318.0	394.5	203.3	195.6	400	600	—	—	186.2	DC FUSE5EFS-350A	DCFH-NH3				
250	7	263	206...F263	289.3	394.5				252.1	242.6	500	750	—	—	230.9	DC FUSE5EFS-450A	DCFH-NH3				
															286.4	DC FUSE5EFS-550A	DCFH-NH3				

(1) Applied rating refers to the motor that is connected to the drive. For example, a F061 drive can be used in Normal Duty mode on a 55 kW motor, or in Heavy Duty mode on a 45 kW motor. The drive can be programmed for either mode. For any given catalog number, Normal Duty mode provides higher continuous current but smaller overload current when compared to Heavy Duty mode. See parameter 0:35 [Duty Rating Cfg].

(2) Only enclosure codes F and N. See the explanation of catalog number positions 8...10 for 690V drives on page 6 for frame sizes of other enclosure types.

(3) For UL compliance - fast-acting class J (Bussmann DF-J) or fast-acting class T (Bussmann JJS) fuses only. Equivalent fuses of class J, T may be used if they have lower I<sub>peak</sub> and I<sub>t</sub> ratings than the Bussmann JJS fuse. For CE compliance - type gR fuses (Bussmann 170M - size 00 to 3, IEC 60269 or DIN 43620, or FWP-610F, -614F, -622F) only. Minimum protection device size is the lowest rated device that supplies maximum protection without nuisance tripping. Max. source SCCR = 100 kA.

(4) For UL compliance - fast-acting class J (Bussmann DF-J) or fast-acting class T (Bussmann JJS) fuses only. Equivalent fuses of class J, T may be used if they have lower I<sub>peak</sub> and I<sub>t</sub> ratings than the Bussmann JJS fuse. For CE compliance - type gR fuses (Bussmann 170M - size 00 to 3, IEC 60269 or DIN 43620, or FWP-610F, -614F, -622F) only. Maximum protection device size is the highest rated device that supplies drive protection. Max. source SCCR = 100 kA.

(5) Circuit breaker - inverse time breaker - must be used with a fuse specified in the table. For US NEC, minimum circuit breaker size is 125% of motor F.L.A. Ratings that are shown are maximum values.

(6) DC fuses specified are UL recognized and CE compliant.

## Cable Considerations

This section provides information for cable types and routing.

### Power Cable Types Acceptable for 200...690 Volt Installations

A variety of cable types are acceptable for drive installations. For an in-depth discussion of cable types, including a table of maximum motor cable lengths, see the PowerFlex 755TS Products with TotalFORCE Control Installation Instructions, publication [750-IN119](#) or Wiring and Grounding Guidelines for Pulse Width Modulated (PWM) AC Drives, publication [DRIVES-INO01](#).

#### Recommended Cable Design

Rating/Type	Description
600V 75 °C (167 °F)	<ul style="list-style-type: none"> <li>Four tinned copper conductors with XLPE insulation.</li> <li>Copper braid/aluminum foil combination shield and tinned copper drain wire.</li> <li>PVC jacket.</li> <li>For surrounding air temperature greater than 50 °C, it is recommended to use wire with insulation rating of 90 °C or higher. However, conductor size shall be determined based on 75 °C rated wire.</li> </ul>

### Selection Considerations

This section provides information for input power cabling, motor cabling, and signal and I/O wiring.

Type		Cable Type(s)	Description	Min. Insulation Rating
<b>Input Power</b> (1) (2)	Standard	—	<ul style="list-style-type: none"> <li>Three tinned copper conductors with XLPE insulation.</li> <li>Maximum 500 MCM conductors.</li> <li>Copper braid/aluminum foil combination shield and tinned copper drain wire, three drain wires per cable assembly.</li> <li>PVC jacket.</li> </ul>	600V, 75 °C (167 °F) <sup>(3)</sup>
<b>Motor</b>	Standard	—	<ul style="list-style-type: none"> <li>Three tinned copper conductors with XLPE insulation.</li> <li>Maximum 500 MCM conductors.</li> <li>Copper braid/aluminum foil combination shield and tinned copper drain wire, three drain wires per cable assembly.</li> <li>PVC jacket.</li> </ul>	400...600V systems: 600V, 75 °C (167 °F) 690V systems: 2000V, 90 °C (194 °F)
<b>Signal</b> (1) (4) (5)	Standard Analog I/O	—	0.750 mm <sup>2</sup> (18 AWG), twisted pair, 100% shield w/drain.	300V, 75...90 °C (167...194 °F)
	Remote Pot	—	0.750 mm <sup>2</sup> (18 AWG), 3 conductor, shielded.	
	Encoder/ Pulse I/O <30 m (100 ft)	Combined	0.196 mm <sup>2</sup> (24 AWG) individually shielded pairs.	
		Signal	0.196 mm <sup>2</sup> (24 AWG) individually shielded pairs.	
		Power	0.750 mm <sup>2</sup> (18 AWG) in.dividually shielded pairs	
	Encoder/ Pulse I/O 30...152 m (100...500 ft)	Combined	0.330 mm <sup>2</sup> (22 AWG), power is 0.500 mm <sup>2</sup> (20 AWG) individually shielded pairs.	
		Signal	0.196 mm <sup>2</sup> (24 AWG) individually shielded pairs.	
Power		0.750 mm <sup>2</sup> (18 AWG) individually shielded pairs.		
Encoder/ Pulse I/O 152...259 m (500...850 ft.)	Combined	0.750 mm <sup>2</sup> (18 AWG) individually shielded pairs.		
	Signal	0.196 mm <sup>2</sup> (24 AWG) individually shielded pairs.		
	Power	0.750 mm <sup>2</sup> (18 AWG) individually shielded pairs.		
<b>Control Power</b>	Un-shielded	—	Per US NEC or applicable national or local code.	300V, 60 °C (140 °F) <sup>(6)</sup>
<b>Digital I/O Safety Inputs Homing Inputs</b> (1) (4) (5) (7)	Un-shielded	—	Per US NEC or applicable national or local code.	300V, 60 °C (140 °F) <sup>(6)</sup>
	Shielded	Multi-conductor shielded cable	0.750 mm <sup>2</sup> (18 AWG), 3 conductor, shielded.	

(1) Signal wires should be separated from power wires by at least 0.3 meters (1 foot).

(2) The use of shielded wire for AC input power may not be necessary but is always recommended.

(3) The minimum insulation rating for input power wire must be at least equal to the nominal system voltage rating.

(4) If the wires are short and contained within a cabinet which has no sensitive circuits, the use of shielded wire may not be necessary, but is always recommended.

(5) I/O terminals labeled '—' or 'Common' are not referenced to earth ground and are designed to greatly reduce common mode interference. Grounding these terminals can cause signal noise. For CE installations, 115V I/O must use shielded cable or have a cable length less than 30 m (98 ft).

(6) 75 °C (140 °F) rated wire or higher is recommended for installations where the surrounding air temperature exceeds 50 °C (122 °F).

(7) Ensure that 120V AC for I/O meets the requirements of overvoltage category II and is supplied with an isolation transformer from the mains power.

## Motor Considerations

Due to the operational characteristics of AC variable frequency drives, motors with inverter grade insulation systems designed to meet or exceed NEMA MG1 Part 31.40.4.2 standards for resistance to spikes of 1600 volts are recommended.

Guidelines must be followed when using non-inverter grade motors to avoid premature motor failures. See Wiring and Grounding Guidelines for Pulse Width Modulated (PWM) AC Drives, publication [DRIVES-IN001](#) for recommendations.

## Dimensions and Weights

This section provides frame and rating cross-references.

### 208V AC and 240V AC

Cat. No.	Light Duty kW Output	Normal Duty kW Output	Heavy Duty kW Output	Cat. No.	Light Duty Hp Output	Normal Duty Hp Output	Heavy Duty Hp Output	Enclosure Code/Frame Size			
208 Volt				240 Volt				F	G	N	R
20G...B2P2	—	0.37 (0.37) <sup>(1)</sup>	0.37 (0.37) <sup>(1)</sup>	20G...B2P2	—	0.5 (0.5) <sup>(1)</sup>	0.5 (0.5) <sup>(1)</sup>	2	2	2	1
20G...B4P2	—	0.75 (0.75) <sup>(1)</sup>	0.75 (0.37) <sup>(1)</sup>	20G...B4P2	—	1 (1) <sup>(1)</sup>	1 (0.5) <sup>(1)</sup>				
20G...B6P8	—	1.5 (1.5) <sup>(1)</sup>	1.5 (0.75) <sup>(1)</sup>	20G...B6P8	—	2 (2) <sup>(1)</sup>	2 (1) <sup>(1)</sup>				
20G...B9P6	—	2.2 (2.2) <sup>(1)</sup>	2.2 (1.5) <sup>(1)</sup>	20G...B9P6	—	3 (3) <sup>(1)</sup>	3 (2) <sup>(1)</sup>				
20G...B015	—	4 (4) <sup>(1)</sup>	2.2 (2.2) <sup>(1)</sup>	20G...B015	—	5 (5) <sup>(1)</sup>	3 (3) <sup>(1)</sup>				
20G...B022	—	5.5	4	20G...B022	—	7.5	5	3	3	3	—
20G...B028	—	7.5	5.5	20G...B028	—	10	7.5				
20G...B042	—	11	7.5	20G...B042	—	15	10				
20G...B054	—	15	11	20G...B054	—	20	15	4	4	4	
20G...B055	—	15	11	20G...B055	—	20	15	—	—	3	
20G...B070	—	18.5	15	20G...B070	—	25	20	5	5	5	
20G...B071	—	18.5	15	20G...B071	—	25	20	4	—	4	
20G...B080	—	22	18.5	20G...B080	—	30	25	5	6	6	
20G...B104	—	30	22	20G...B104	—	40	30	6 <sup>(2)</sup>			
20G...B130	—	37	30	20G...B130	—	50	40				
20G...B154	—	45	37	20G...B154	—	60	50				
20G...B192	—	55	45	20G...B192	—	75	60	7 <sup>(2)</sup>			
20G...B260	—	66	55	20G...B260	—	100	75				
20G...B312	—	90	66	20G...B312	—	125	100				
20G...B360	—	110	90	20G...B360	—	150	125	7	7		
20G...B477	—	132	90	20G...B477	—	200	125			—	

(1) Ratings in parenthesis are only applicable for Frame 1.

(2) For Frames 6 and 7, a user-installed flange kit (catalog number 20-750-TFLNG1-Fn) is available to convert a code N drive that provides a NEMA/UL Type 4X/12 back.

## 400V AC and 480V AC

Cat. No.	Light Duty kW Output	Normal Duty kW Output	Heavy Duty kW Output	Cat. No.	Light Duty Hp Output	Normal Duty Hp Output	Heavy Duty Hp Output	Enclosure Code/Frame Size				
								F	G	N	R	
<b>400 Volt</b>				<b>480 Volt</b>								
20G...C2P1	—	0.75 (0.75) <sup>(1)</sup>	0.75 (0.37) <sup>(1)</sup>	20G...D2P1	—	1 (1) <sup>(1)</sup>	1 (0.5) <sup>(1)</sup>	2	2	2	1	
20G...C3P5	—	1.5 (1.5) <sup>(1)</sup>	1.5 (0.75) <sup>(1)</sup>	20G...D3P4	—	2 (2) <sup>(1)</sup>	2 (1.5) <sup>(1)</sup>					
20G...C5P0	—	2.2 (2.2) <sup>(1)</sup>	2.2 (1.5) <sup>(1)</sup>	20G...D5P0	—	3 (3) <sup>(1)</sup>	3 (2) <sup>(1)</sup>					
20G...C8P7	—	4 (4) <sup>(1)</sup>	4 (2.2) <sup>(1)</sup>	20G...D8P0	—	5 (5) <sup>(1)</sup>	5 (3) <sup>(1)</sup>					
20G...C011	—	5.5 (5.5) <sup>(1)</sup>	5.5 (4) <sup>(1)</sup>	20G...D011	—	7.5 (7.5) <sup>(1)</sup>	7.5 (5) <sup>(1)</sup>					
20G...C015	—	7.5 (7.5) <sup>(1)</sup>	5.5 (5.5) <sup>(1)</sup>	20G...D014	—	10 (10) <sup>(1)</sup>	7.5 (7.5) <sup>(1)</sup>					
20G...C022	—	11	7.5	20G...D022	—	15	10					
20G...C030	—	15	11	20G...D027	—	20	15	3	3	3		
20G...C037	—	18.5	15	20G...D034	—	25	20					
20G...C043	—	22	18.5	20G...D040	—	30	25					
20G...C060	—	30	22	20G...D052	—	40	30	4	4	4	—	
20G...C061	—	30	22	20G...D053	—	40	30	—	—	3		
20G...C072	—	37	30	20G...D065	—	50	40	4	5	4		
20G...C073	—	37	30	20G...D066	—	50	40	—	4	—		
20G...C085	—	45	37	20G...D077	—	60	50	5	5	5		
20G...C086	—	45	37	20G...D078	—	60	50	4	—	4		
20G...C104	—	55	45	20G...D096	—	75	60	5	6	5		
20G...C140	—	75	55	20G...D125	—	100	75	6 <sup>(2)</sup>		6		6
20G...C170	—	90	75	20G...D156	—	125	100					
20G...C205	—	110	90	20G...D186	—	150	125					
20G...C260	—	132	110	20G...D248	—	200	150	7 <sup>(2)</sup>	7	7		
20G...C302	—	160	132	20G...D302	—	250	200					
20G...C367	—	200	160	20G...D361	—	300	250					
20G...C456	—	250	200	20G...D415	—	350	300					
20G...C477	—	270	200	20G...D477	—	400	300					

(1) Ratings in parenthesis are only applicable for Frame 1.

(2) For Frames 6 and 7, a user-installed flange kit (catalog number 20-750-TFLNG1-Fn) is available to convert a code N drive that provides a NEMA/UL Type 4X/12 back.

## 600V AC and 690V AC

Cat. No.	Light Duty kW Output	Normal Duty kW Output	Heavy Duty kW Output	Cat. No.	Light Duty Hp Output	Normal Duty Hp Output	Heavy Duty Hp Output	Frame Enclosure Code		
								F	G	N
<b>600 Volt</b>				<b>690 Volt</b>						
20G...E1P7	—	1	0.5					2	2	2
20G...E2P7	—	2	1							
20G...E3P9	—	3	2							
20G...E6P1	—	5	3							
20G...E9P0	—	7.5	5							
20G...E011	—	10	7.5							
20G...E012	—	10	7.5	20G...F012	—	7.5	5.5			
20G...E017	—	15	10							
20G...E018	—	15	10	20G...F015	—	11	7.5			
20G...E022	—	20	15							
20G...E023	—	20	15	20G...F020	—	15	11	3	3	3
20G...E024	—	20	20	20G...F023	—	18.5	15			
20G...E027	—	25	27							
20G...E028	—	25	20	20G...F030	—	22	18.5	4	4	4
20G...E032	—	30	25					—	—	3
20G...E033	—	30	25	20G...F034	—	30	22	4	5	4
20G...E041	—	40	30					—	4	—
20G...E042	—	40	30	20G...F046	—	37	30	5	5	5
20G...E052	—	50	40					4	—	4
20G...E053	—	50	40	20G...F050	—	45	37	5	6 <sup>(1)</sup>	5
20G...E063	—	60	50	20G...F061	—	55	45	6		6
20G...E77	—	75	60	20G...F082	—	75	55			
20G...E099	—	100	75	20G...F098	—	90	75			
20G...E125	—	125	100	20G...F119	—	110	90	7 <sup>(1)</sup>	7	7
20G...E144	—	150	125	20G...F142	—	132	110			
20G...E192	—	200	150	20G...F171	—	160	132			
20G...E242	—	250	200	20G...F212	—	200	160		—	—
20G...E289	—	300	250	20G...F263	—	250	200			

(1) For Frames 6 and 7, a user-installed flange kit (catalog number 20-750-TFLNG1-Fn) is available to convert a code N drive that provides a NEMA/UL Type 4X/12 back.

## Enclosure Options

**IMPORTANT** IP00, IP20, and NEMA/UL Open Type PowerFlex 755TS drives must be installed in a clean, dry location. Contaminants such as oils, corrosive vapors and abrasive debris must be kept out of the enclosure. These enclosures are intended for indoor use primarily to provide a degree of protection against contact with enclosed equipment. These enclosures offer no protection against airborne contaminants. See the following tables for an explanation of enclosure options and the environmental specifications found on [page 23](#). See Industry Installation Guidelines for Pulse Width Modulated (PWM) AC Drives, publication [DRIVES-AT003](#) for additional information.

## Pollution Degree Ratings According to EN 61800-5-1

Pollution Degree	Description
1	No pollution or only dry, non-conductive pollution occurs. The pollution has no influence.
2	Normally, only non-conductive pollution occurs. Occasionally, however, a temporary conductivity caused by condensation is to be expected, when the drive is out of operation.
3	Conductive pollution or dry non-conductive pollution occurs, which becomes conductive due to condensation, which is to be expected.
4	The pollution generates persistent conductivity caused, for example by conductive dust or rain or snow.

## Product Enclosure Ratings

Frames	Enclosure Type (Cat. No. Position 6)	Installed Accessory Kit	Front Side Rating		Back Side/Heat Sink Rating	
			Enclosure Type	Pollution Degree	Enclosure Type	Pollution Degree
1	R	None	IP20, NEMA/UL Open Type	1, 2	IP20, NEMA/UL Open Type	1, 2
		NEMA Type 1	IP20, NEMA/UL Type 1	1, 2	IP20, NEMA/UL Type 1	1, 2
2...5	N	None	IP20, NEMA/UL Open Type	1, 2	IP20, NEMA/UL Open Type	1, 2
		NEMA Type 1	IP20, NEMA/UL Type 1	1, 2	IP20, NEMA/UL Type 1	1, 2
		Flange	IP20, NEMA/UL Type 1	1, 2	IP20, NEMA/UL Type 1	1, 2
	F	None	IP20, NEMA/UL Open Type	1, 2	IP66, NEMA/UL Type 4X	1, 2, 3, 4
	G	None	IP54, NEMA/UL Type 12	1, 2, 3, 4	IP54, NEMA/UL Type 12	1, 2, 3, 4
6 and 7	N	None	IP00, NEMA/UL Open Type	1, 2	IP00, NEMA/UL Open Type Kit	1, 2
		NEMA Type 1	IP20, NEMA/UL Type 1	1, 2	IP20, NEMA/UL Type 1	1, 2
		NEMA Type 4X flange	IP00, NEMA/UL Open Type	1, 2	IP66, NEMA/UL Type 4X	1, 2, 3, 4
	G	None	IP54, NEMA/UL Type 12	1, 2, 3, 4	IP54, NEMA/UL Type 12	1, 2, 3, 4

## Minimum Mounting Clearances

Specified vertical clearance requirements are intended to be from the PowerFlex 755TS product to the closest object that can restrict airflow through the cabinet. The product must be mounted in a vertical orientation as shown and must make full contact with the mounting surface. In addition, inlet air temperature must not exceed the product specification.

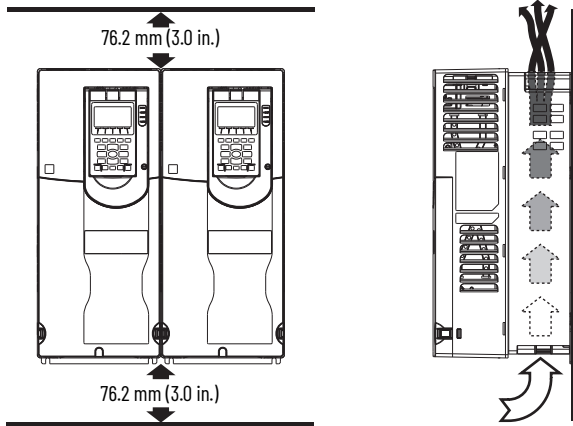

Airflow through the heat sink must not be impeded.  
No clearance between wall mount products is required.

## Approximate Weights

Drive	Frame Size	Drive Rating		Enclosure Code/Weight [kg (lb)]				
		kW (1)	Hp (2)	F	G	N	R	
Standard AC input and common DC input	1	0.37...7.5	0.5...10					6 (13)
	2	0.37...11	0.5...15	8 (18)	8 (18)	8 (18)		
	3	7.5...30	10...40	12 (26)	12 (26)	12 (26)		
	4	15...45	20...60	14 (31)	14 (31)	14 (31)		
	5	18.2...55	25...75	21 (46)	21 (46)	21 (46)		
	6	30...132	30...200	48 (106)	100 (220)	48 (106)		
	7	66...270	100...400	72 (159)	132 (291)	82 (181)		

(1) kW ratings are for 208V, 400V, and 690V drives.

(2) Hp ratings are for 240V, 480V, and 600V drives.

# PowerFlex 755TS Drives Approximate Dimensions

This section provides the approximate dimensions for the drives.

## Dimension Drawing Index

Frame	Description	Page
1	IP20, NEMA/UL Open Type	226
2	IP20, NEMA/UL Open Type	226
	Flange Mount	227
	IP54, NEMA/UL Type 12	228
3	IP20, NEMA/UL Open Type	228
	Flange Mount	229
	IP54, NEMA/UL Type 12	230
4	IP20, NEMA/UL Open Type	230
	Flange Mount	231
	IP54, NEMA/UL Type 12	232
5	IP20, NEMA/UL Open Type	232
	Flange Mount	233
	IP54, NEMA/UL Type 12	234
6	IP00, NEMA/UL Open Type	235
	Flange Mount	236
	IP54, NEMA/UL Type 12	237
7	IP00, NEMA/UL Open Type	238
	Flange Mount	239
	NEMA/UL Type 1	240
	IP54, NEMA/UL Type 12	241
1..6	NEMA/UL Type 1 Kit	242
1..5	NEMA/UL Type 1 Bottom View	243

## Frame Type Approximate Dimensions [mm (in.)]

1, 2 IP20, NEMA/UL Open Type

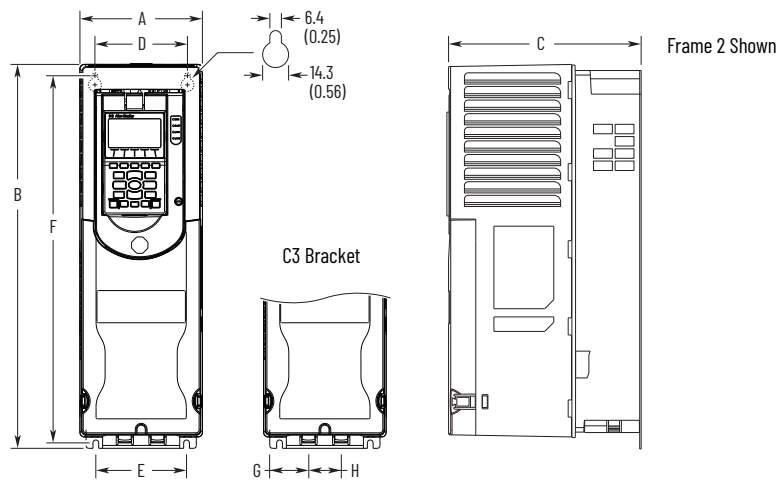

Frame	A	B	C	D	E	F	G	H
1 <sup>(1)</sup>	109.0 (4.3)	400.0 (15.7)	211.1 (8.3)	68.0 (2.7)	82.0 (3.2)	390.3 (15.4)	28.8 (1.1)	36.0 (1.4)
2	135.0 (5.3)	424.2 (16.7)	212.0 (8.3)	100.0 (3.9)	100.0 (3.9)	404.2 (15.9)	42.8 (1.7)	36.0 (1.4)

(1) With the supplied C3 bracket installed on the frame 1 drive, dimension B is 431.4 mm (17.0 in.).

Frame	Type	Approximate Dimensions [mm (in.)]
-------	------	-----------------------------------

2	Flange Mount	
---	--------------	--

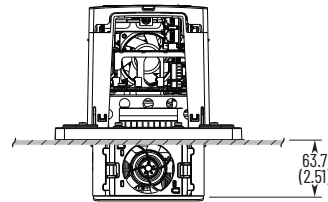
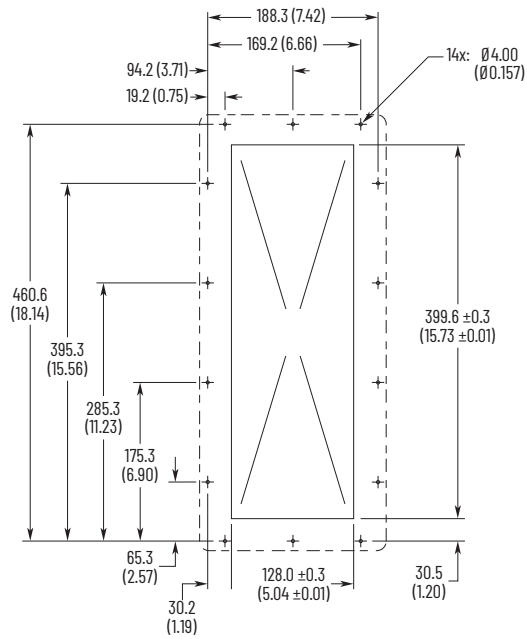
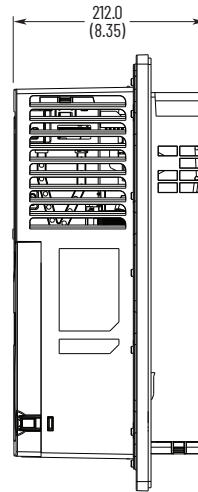
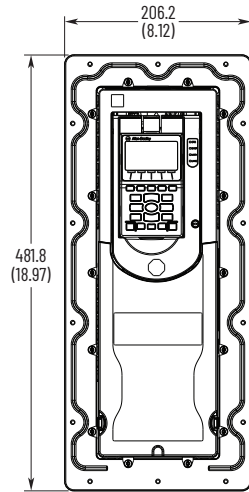

**Important:** Supplied mounting hardware must be used to meet enclosure rating.

Frame	Type	Approximate Dimensions [mm (in.)]
-------	------	-----------------------------------

2	IP54, NEMA/UL Type 12	
---	--------------------------	--

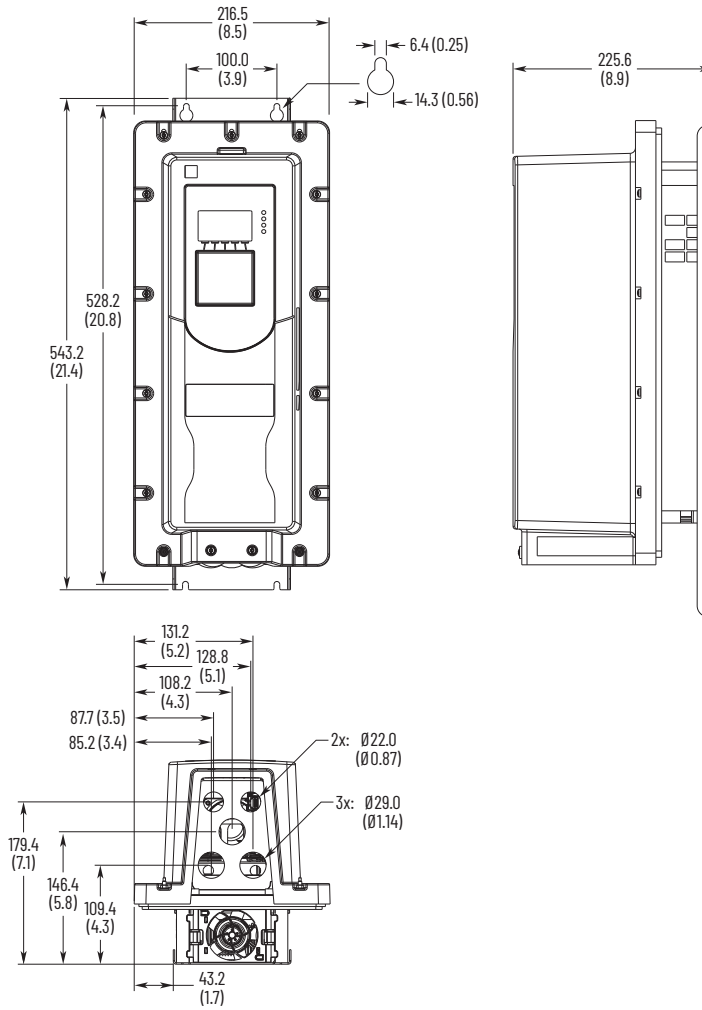

3	IP20, NEMA/UL Open Type	
---	----------------------------	--

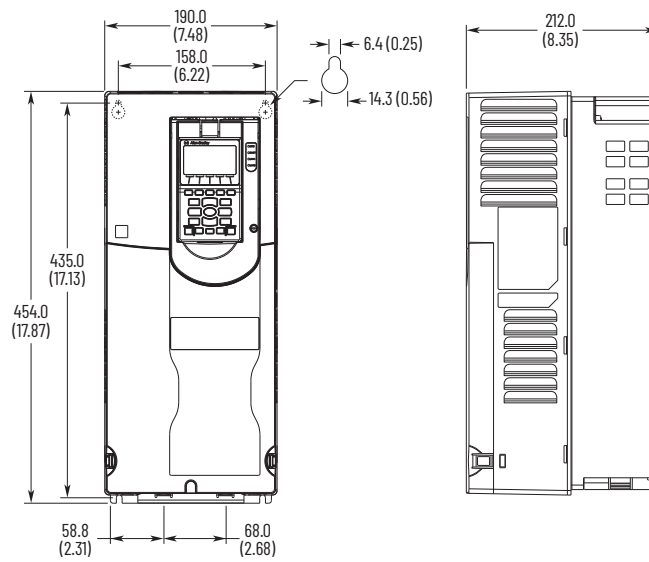

Frame	Type	Approximate Dimensions [mm (in.)]
-------	------	-----------------------------------

3	Flange Mount	
---	--------------	--

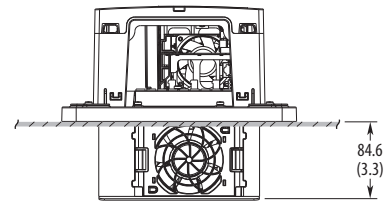
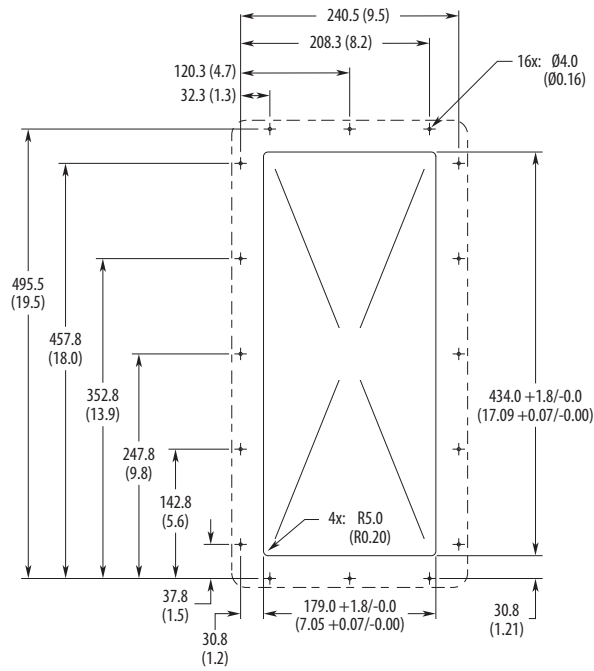
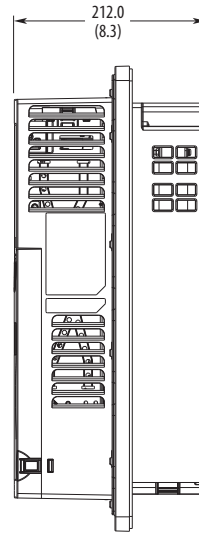
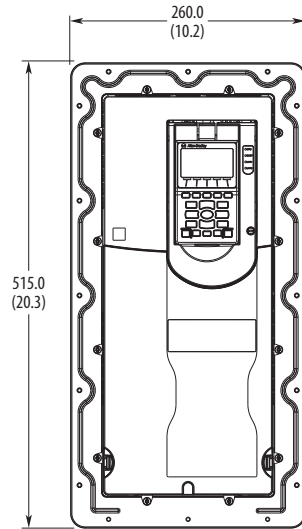

**Important:** Supplied mounting hardware must be used to meet enclosure rating.

**Frame Type Approximate Dimensions [mm (in.)]**

3 IP54, NEMA/UL Type 12

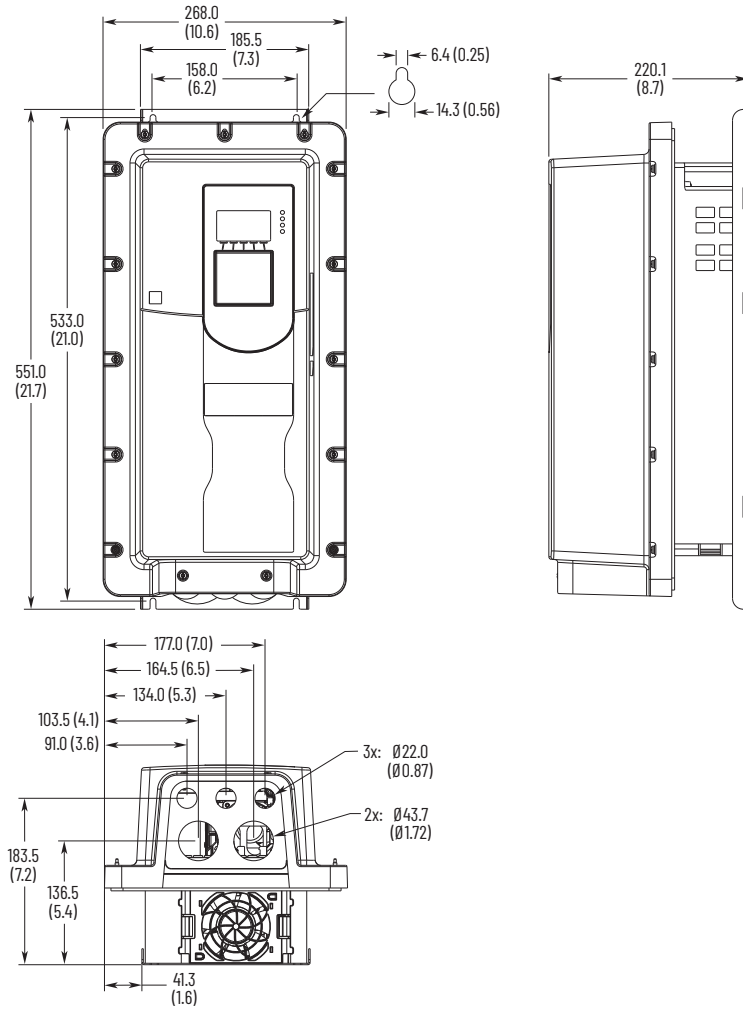

4 IP20, NEMA/UL Open Type

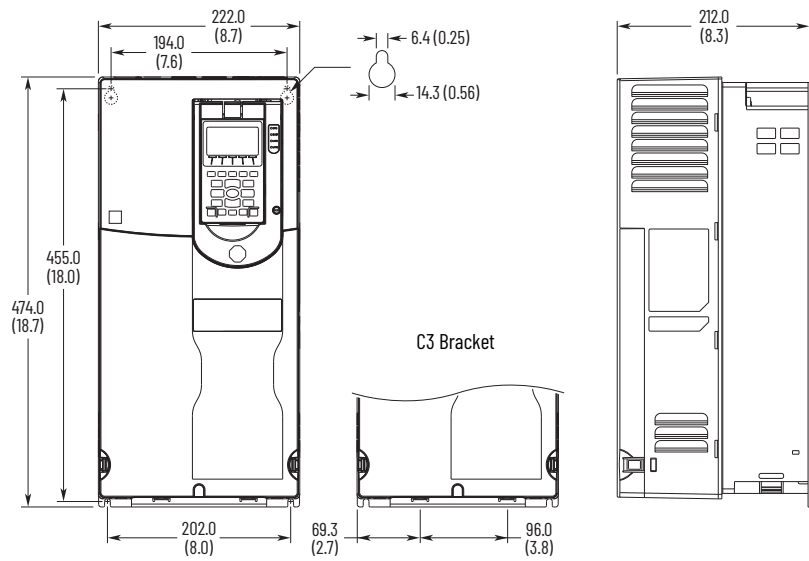

Frame	Type	Approximate Dimensions [mm (in.)]
-------	------	-----------------------------------

4	Flange Mount	
---	--------------	--

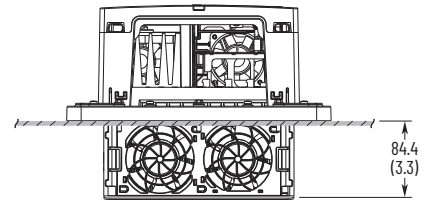
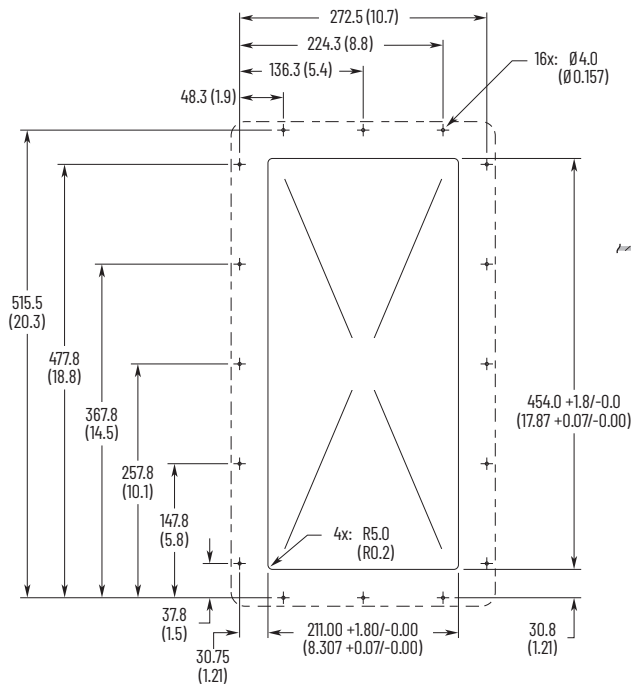
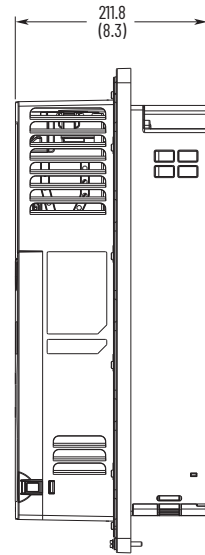
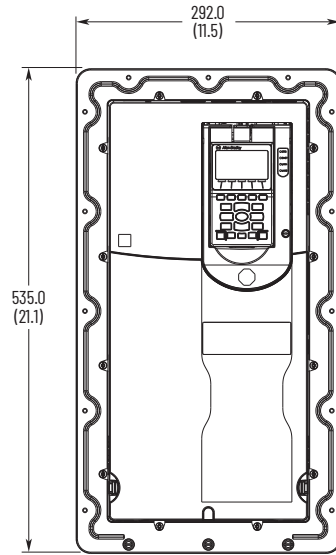

**Important:** Supplied mounting hardware must be used to meet enclosure rating.

**Frame Type Approximate Dimensions [mm (in.)]**

4 IP54, NEMA/UL Type 12

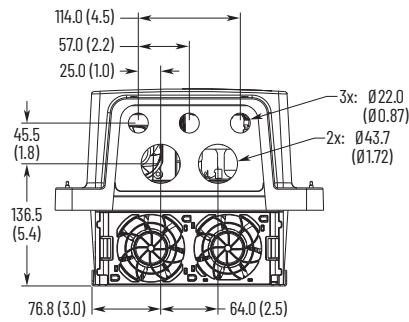
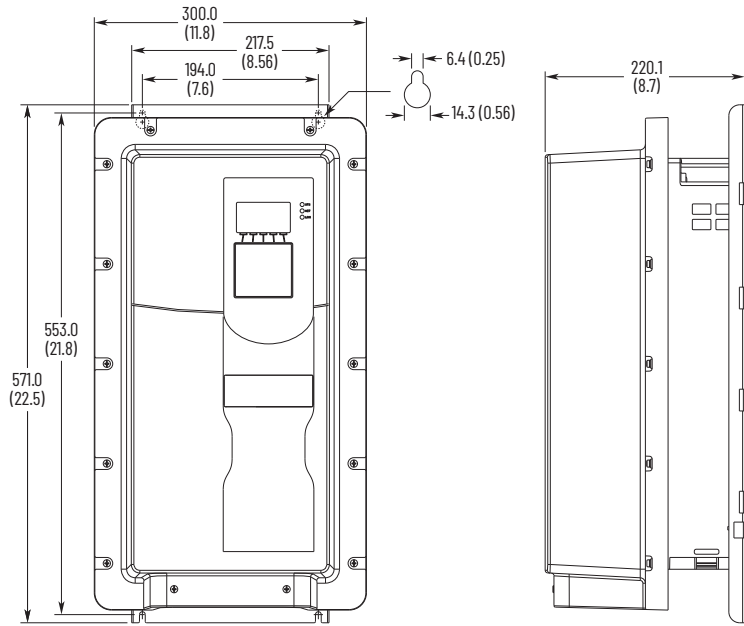

5 IP20, NEMA/UL Open Type

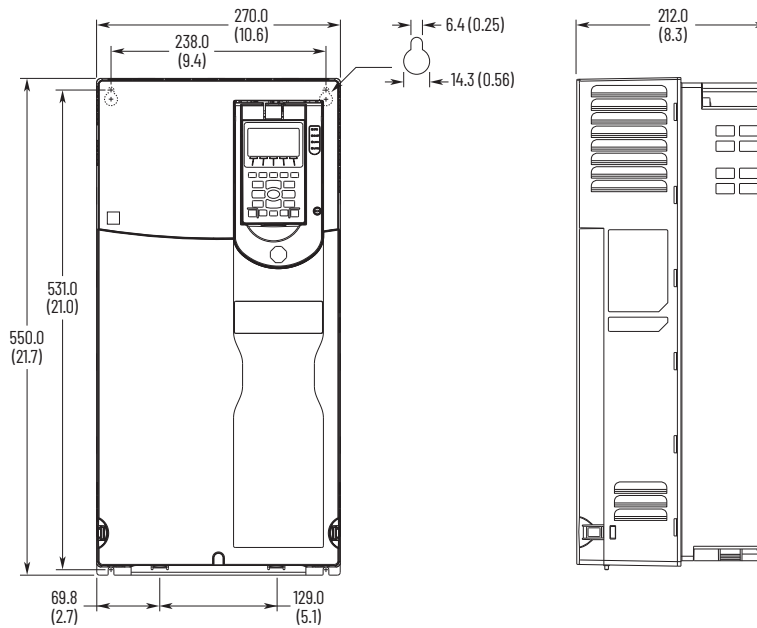

**Frame Type Approximate Dimensions [mm (in.)]**

5 Flange Mount

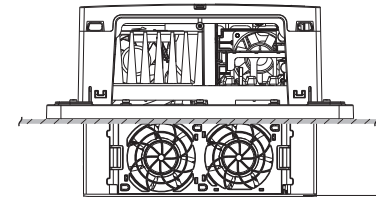
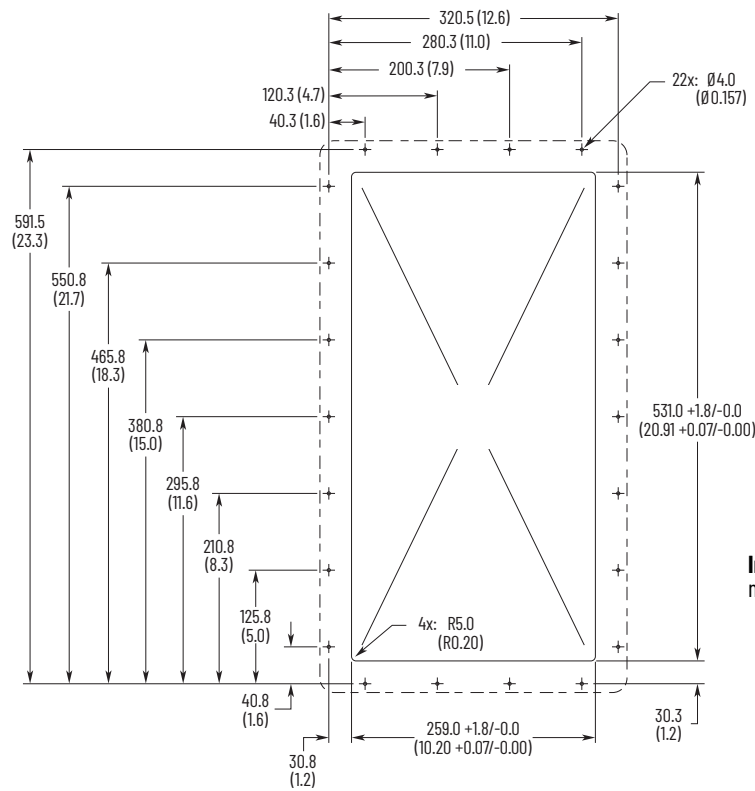
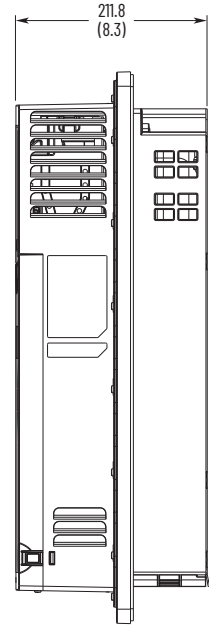
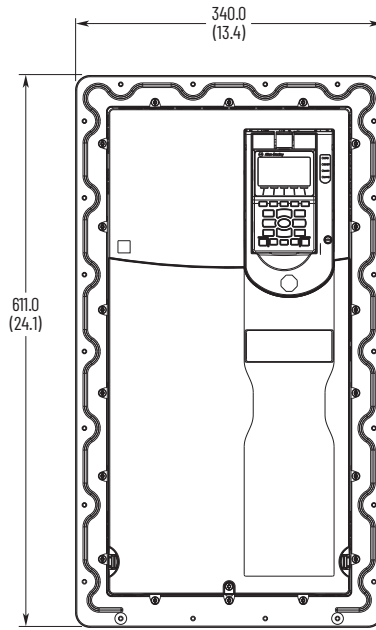

**Important:** Supplied mounting hardware must be used to meet enclosure rating.

Frame	Type	Approximate Dimensions [mm (in.)]
-------	------	-----------------------------------

5	IP54, NEMA/UL Type 12	
---	--------------------------	--

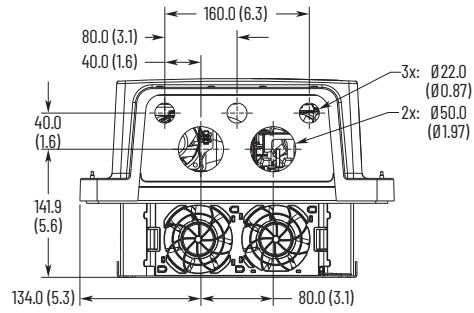
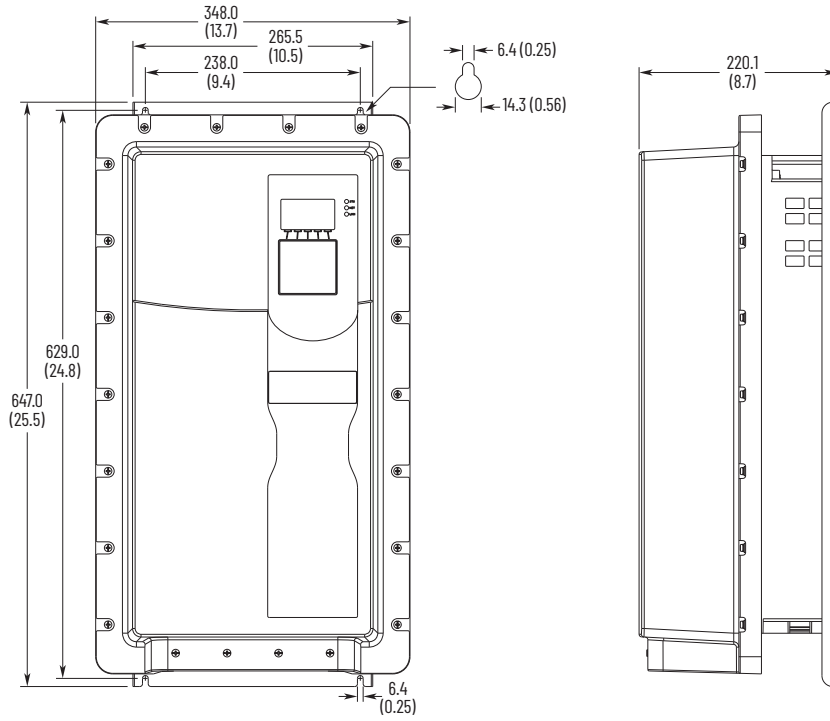

Frame	Type	Approximate Dimensions [mm (in.)]
-------	------	-----------------------------------

6	IPO0, NEMA/UL Open Type	
---	----------------------------	--

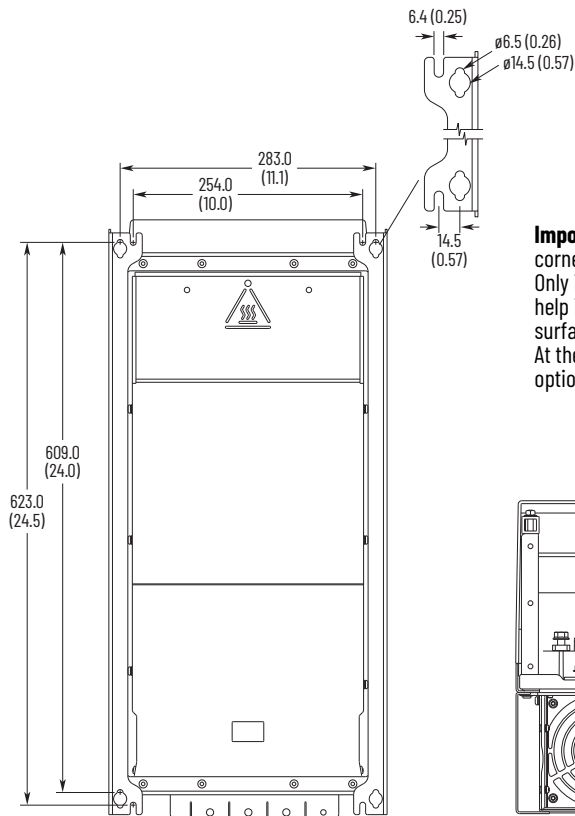
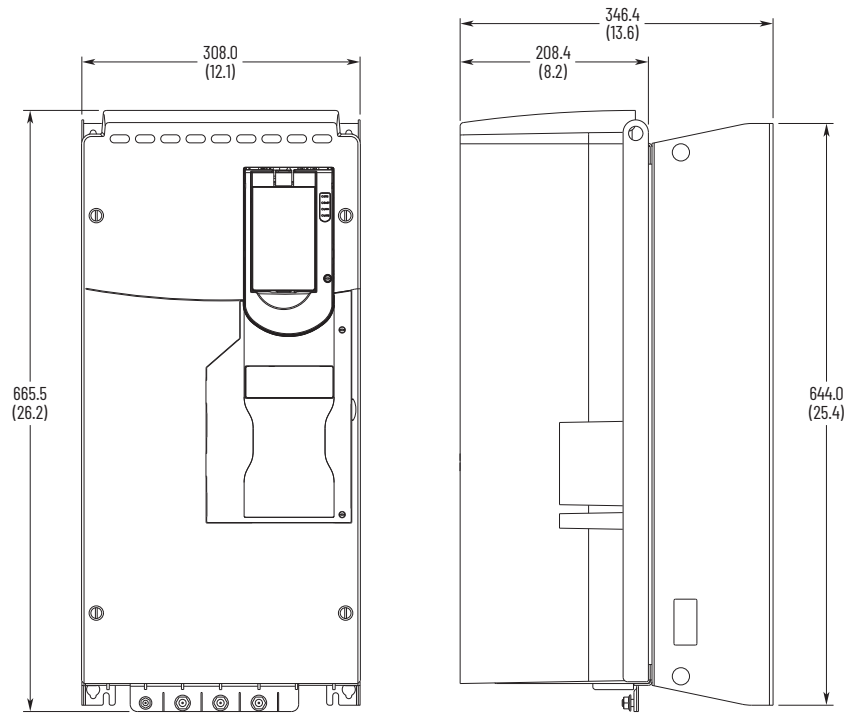

**Important:** Always install mounting hardware in all four corners of the mounting legs for stability. Only install mounting hardware through the top key holes to help insure the drive is securely fastened to the mounting surface. At the bottom of the mounting legs, either the key holes or optional open mounting slots can be used.

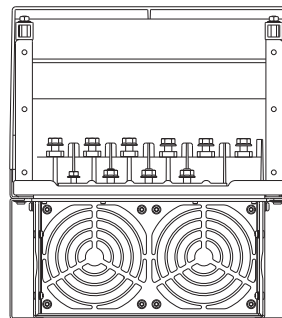

**Frame Type Approximate Dimensions [mm (in.)]**

6 Flange Mount

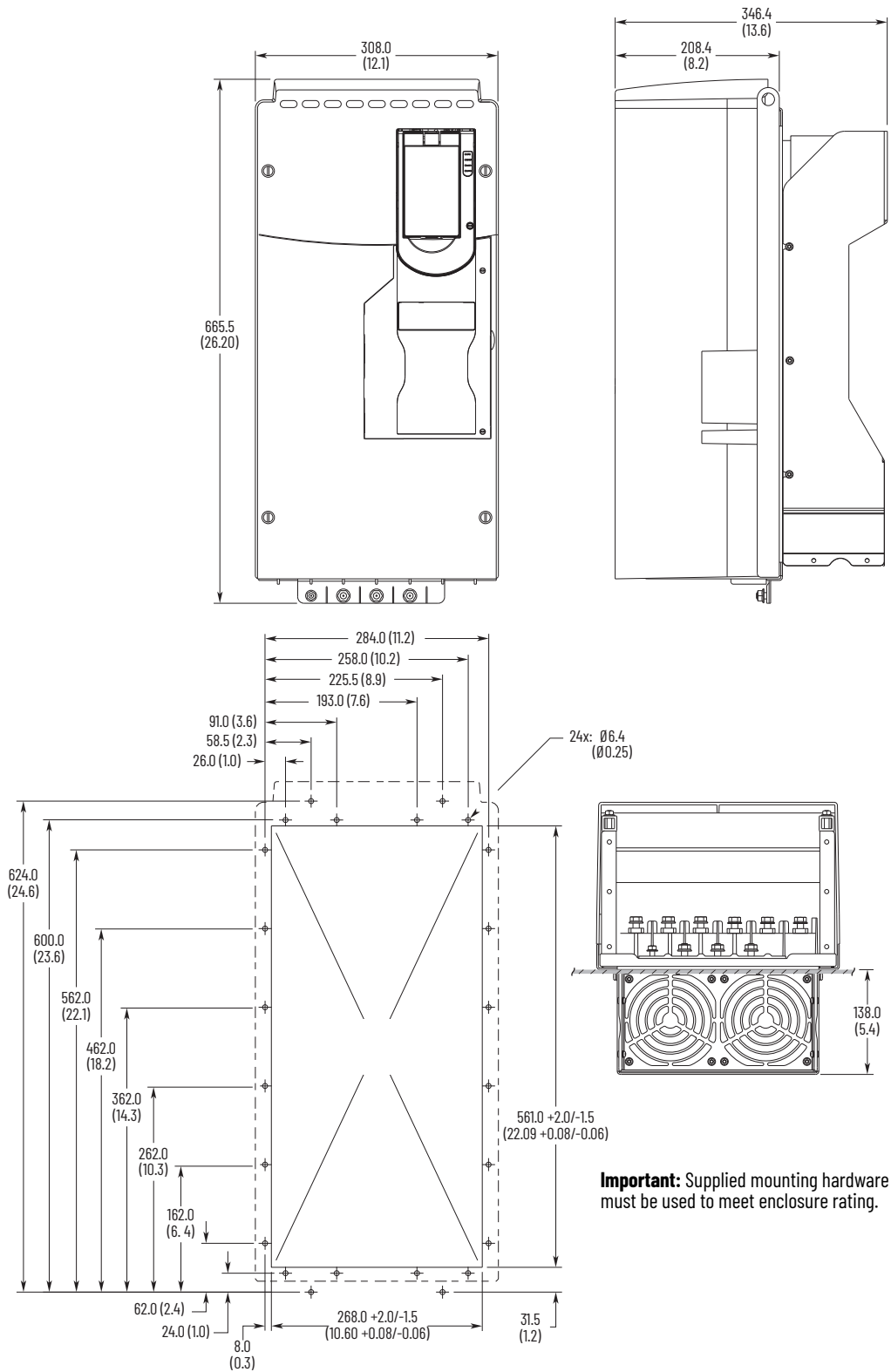

**Frame Type Approximate Dimensions [mm (in.)]**

6 IP54, NEMA/UL Type 12

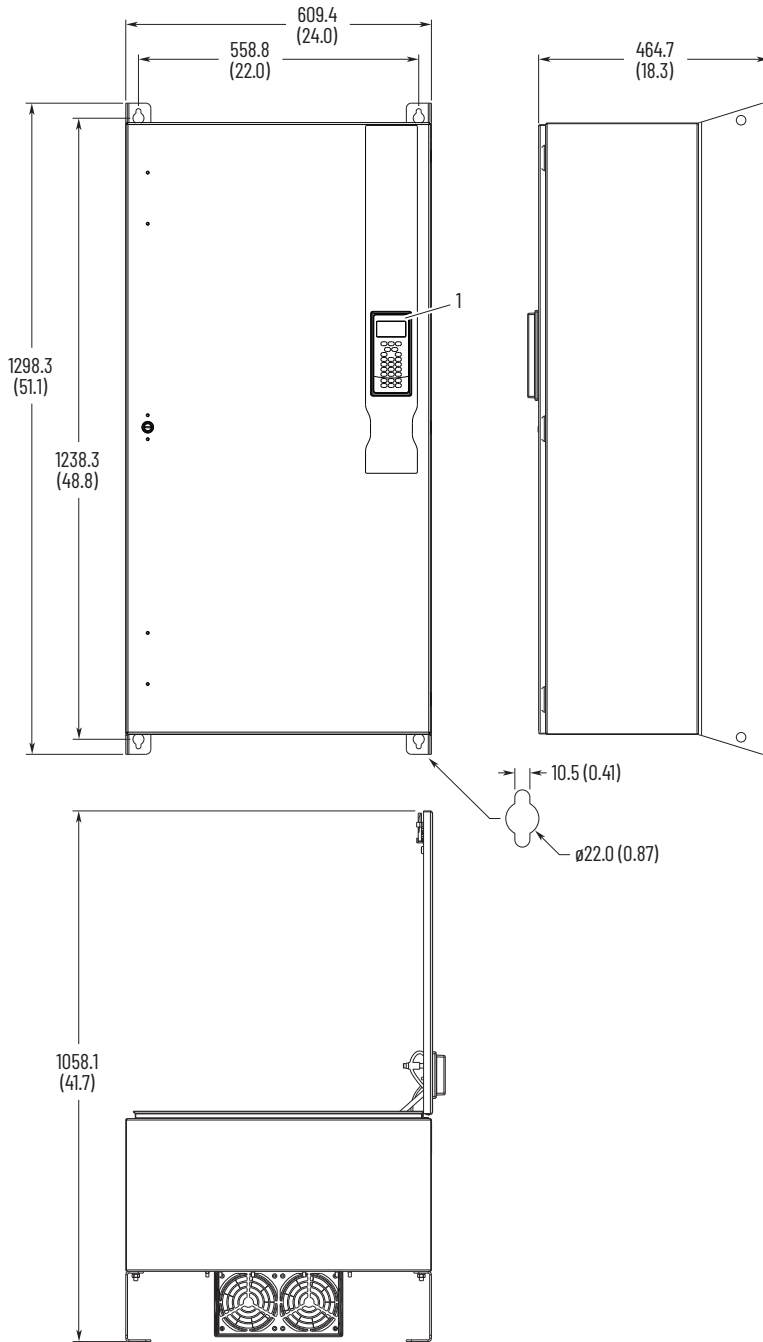

Item	Description
1	Shown with the field-installed 20-HIM-C6S.

Frame	Type	Approximate Dimensions [mm (in.)]
-------	------	-----------------------------------

7	IPO0, NEMA/UL Open Type	
---	----------------------------	--

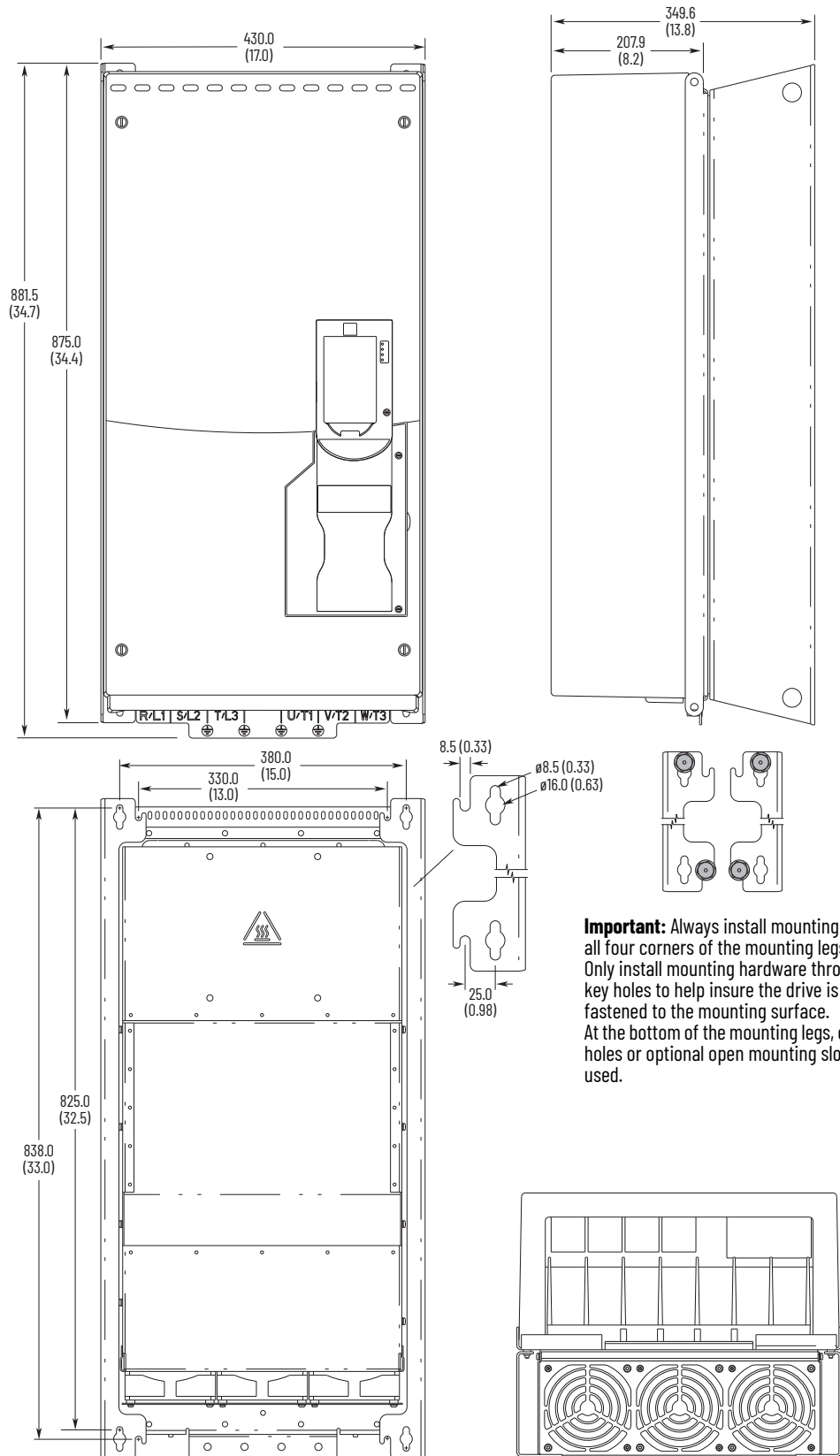

**Important:** Always install mounting hardware in all four corners of the mounting legs for stability. Only install mounting hardware through the top key holes to help insure the drive is securely fastened to the mounting surface. At the bottom of the mounting legs, either the key holes or optional open mounting slots can be used.

**Frame Type Approximate Dimensions [mm (in.)]**

7 Flange Mount

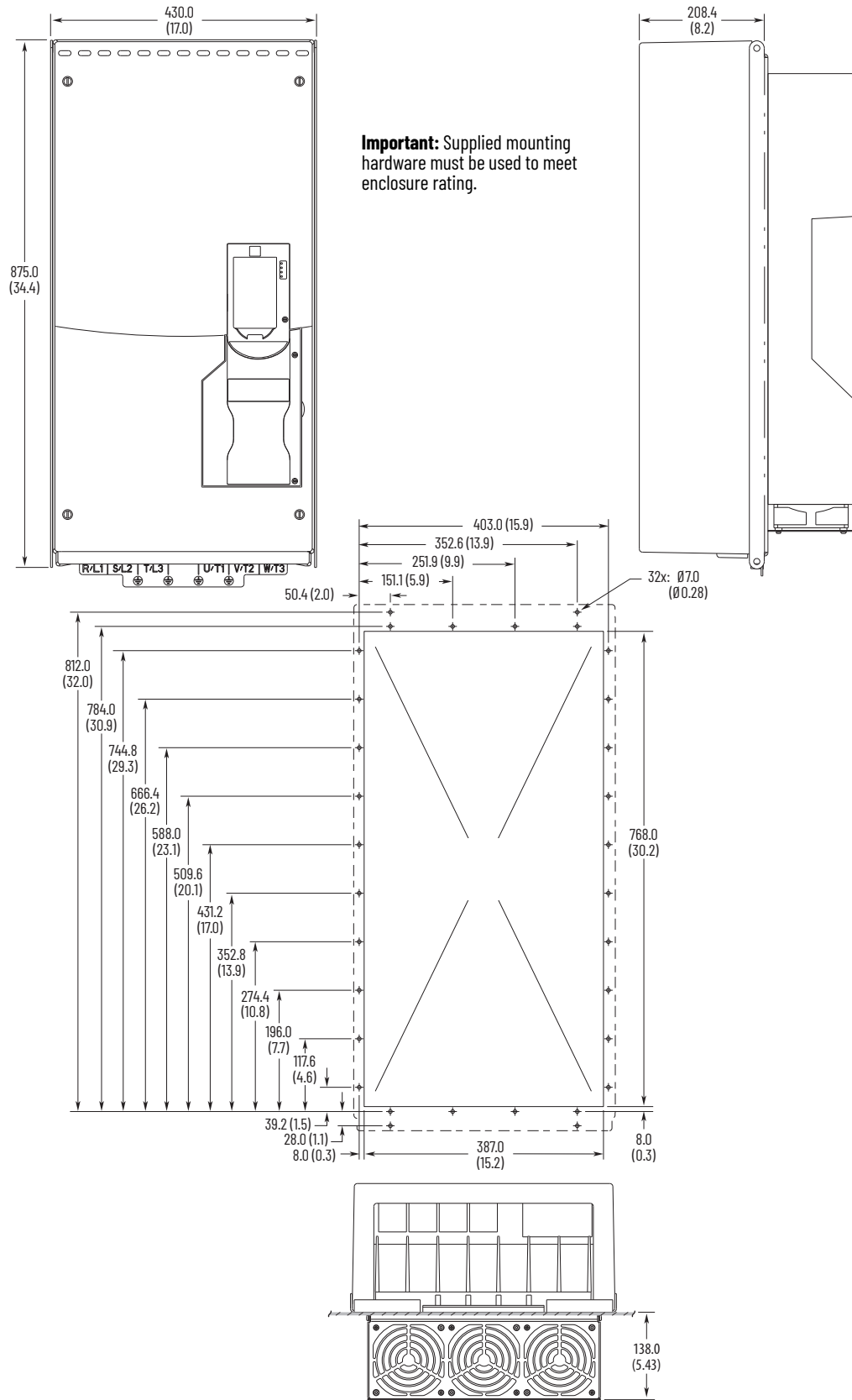

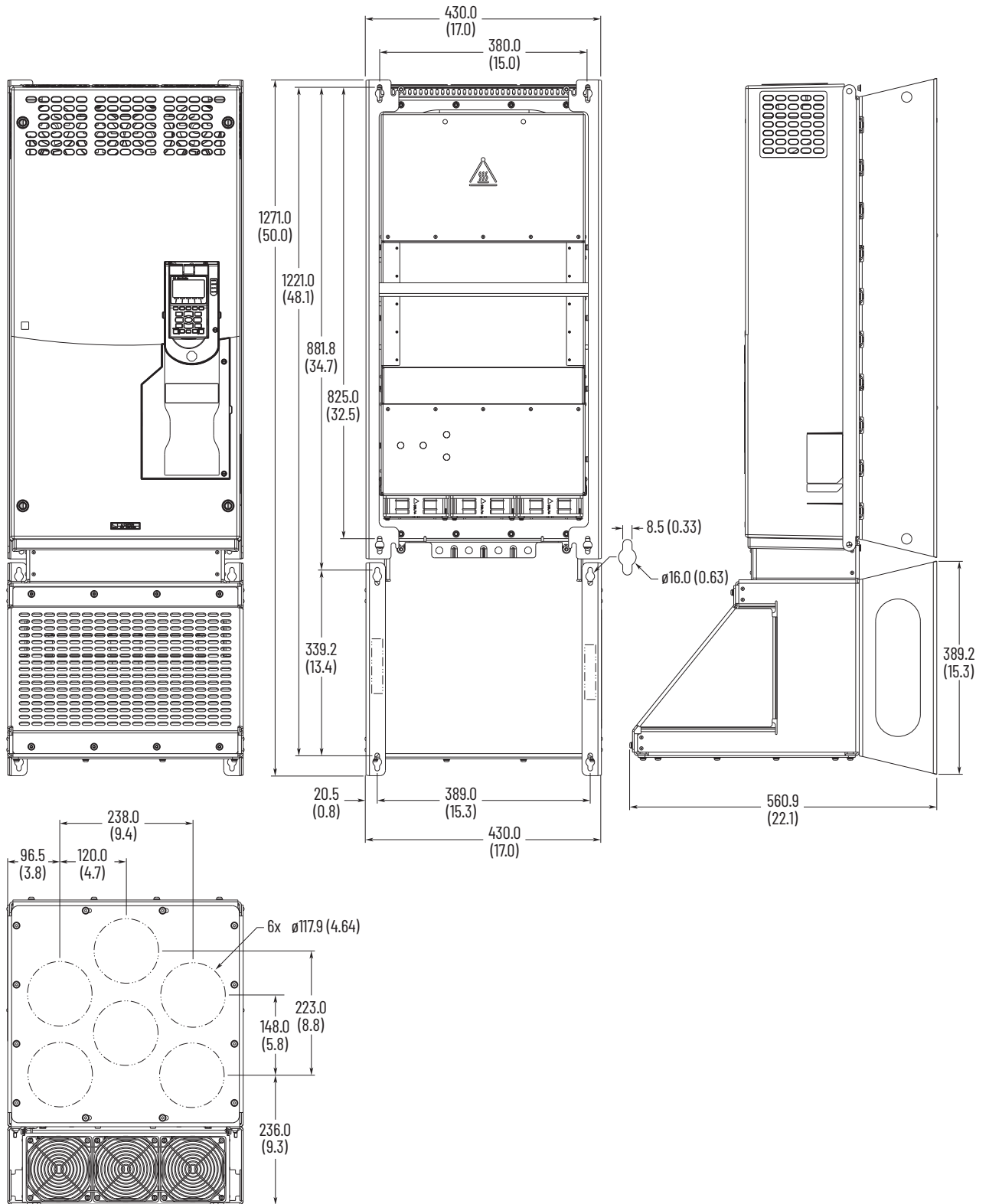

**Frame Type Approximate Dimensions [mm (in.)]**

7 IP54, NEMA/UL Type 12

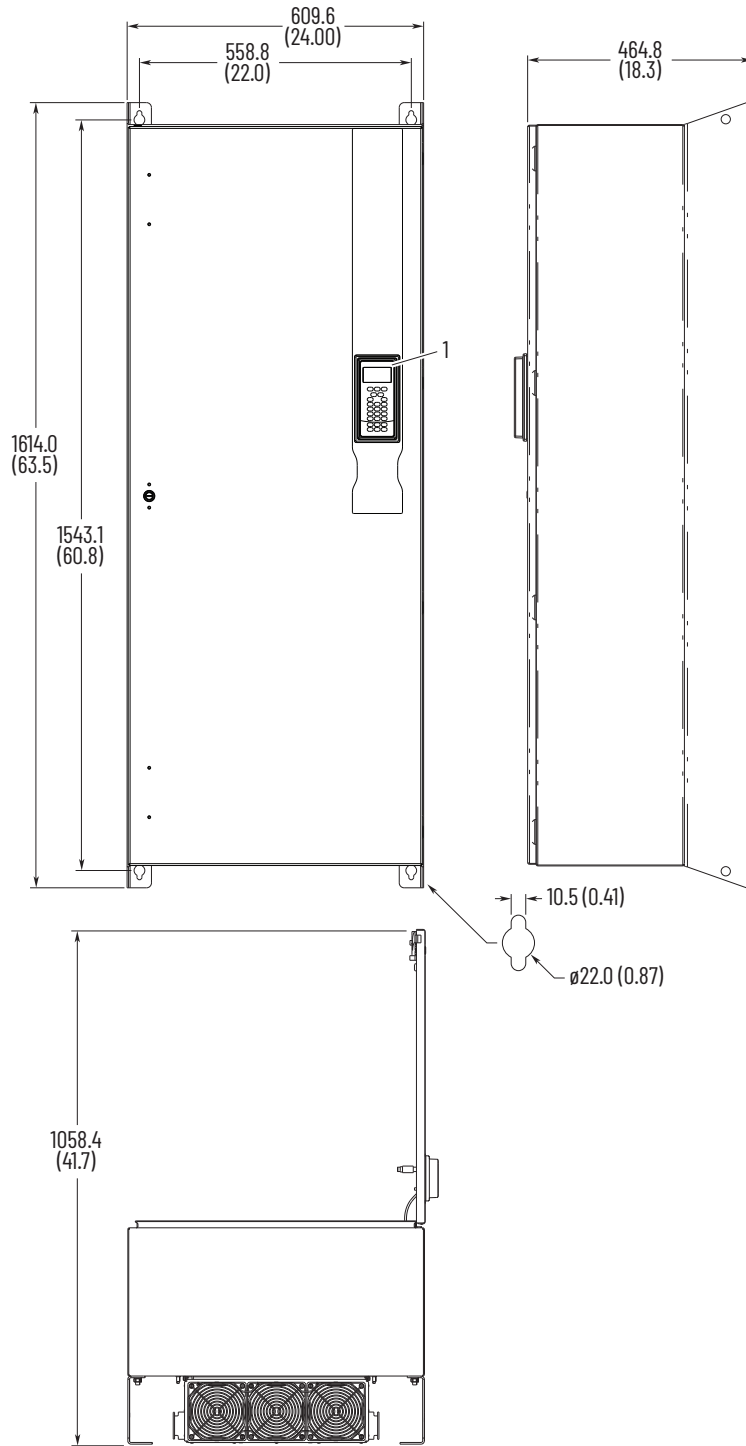

Item	Description
1	Shown with the field-installed 20-HIM-C6S.

**Frame Type Approximate Dimensions [mm (in.)]**

1...5 NEMA/UL Type 1 Kit

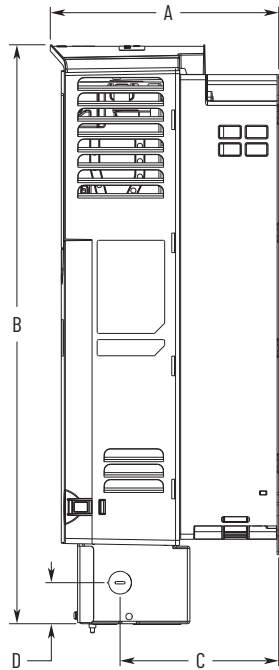

Frame 4 Shown

Frame	A	B	C	D
1	215.4 (8.5)	458.8 (18.1)	—	—
2	222.2 (8.7)	497.1 (19.6)	117.7 (4.6)	38.0 (1.5)
3 (1)	223.1 (8.8)	530.1 (20.9)	154.7 (6.1)	38.0 (1.5)
4	222.7 (8.8)	564.4 (22.2)	154.7 (6.1)	40.0 (1.6)
5	222.7 (8.8)	665.4 (26.2)	155.0 (6.1)	55.0 (2.2)

(1) NEMA/UL Type 1 for 40 HP/30 kW ND frame 3 drives, kit number 20-750-TNEMA1-F3.

**IMPORTANT:** NEMA/UL Type 1 Kits (20-750-NEMA1-Fn) do not change the mounting dimensions.

6 NEMA/UL Type 1 Kit

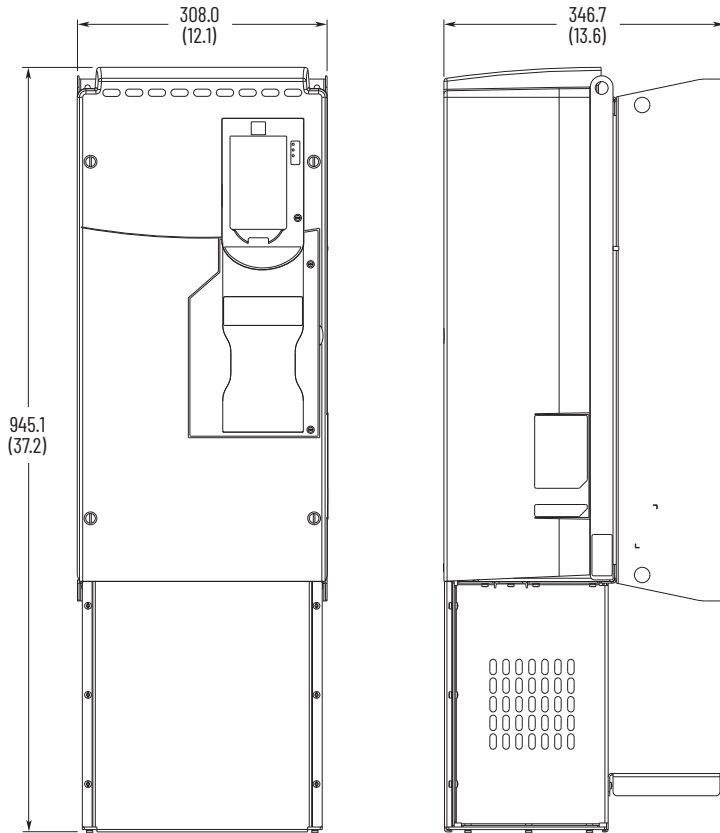

**Frame Type Approximate Dimensions [mm (in.)]**

1...5 NEMA/UL Type 1  
Bottom View

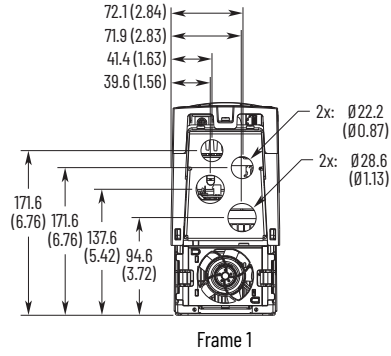

Frame 1

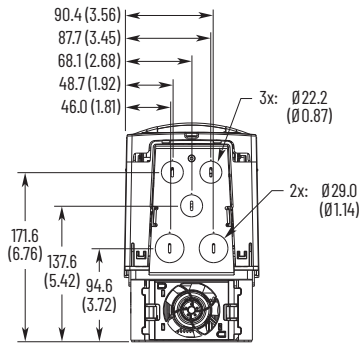

Frame 2

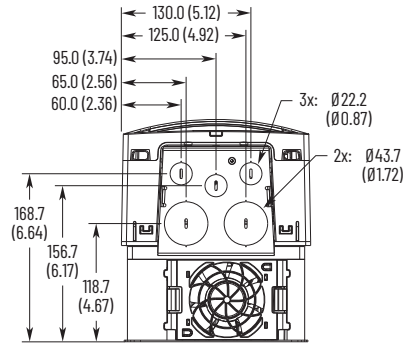

Frame 3

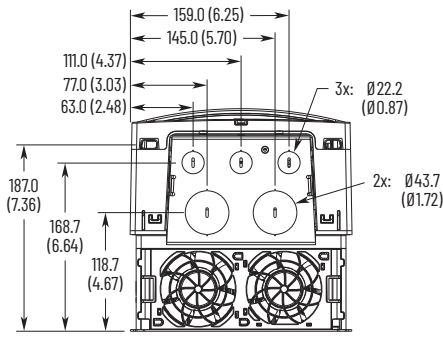

Frame 4

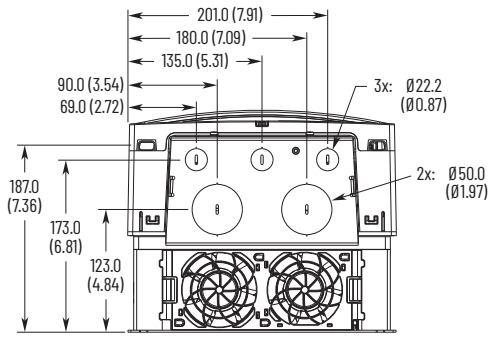

Frame 5

## Drive Options

This section provides information on options that are available for PowerFlex 755TS products with TotalFORCE control.

### Human Interface Modules

PowerFlex 755TS products with TotalFORCE control are compatible only with the enhanced PowerFlex 7-Class human interface modules listed here. Order a HIM option separately for PowerFlex 755TS products.



Cat. No.	Description
20-HIM-A0	No HIM (Blank Plate)
20-HIM-A6	Enhanced, LCD, Full Numeric, Handheld/Local
20-HIM-C6S	Enhanced, LCD, Full Numeric, IP66 NEMA Type 4X/12 (for indoor use only) <sup>(1)</sup>

(1) Includes a 1202-C30 interface cable (3 meters) for connection to drive.

### Specifications - Human Interface Modules

Specification	20-HIM-A6 <sup>(1)</sup>	20-HIM-C6S <sup>(1)</sup>
Drive Protocol: Data Rates:	Drive Peripheral Interface (DPI) 125 kbps or 500 kbps	
Consumption Drive (DPI):	140 mA at 12V DC supplied by the Host Drive	
Dimensions - H x W x D 20-HIM-A6: 20-HIM-C6S:	116 x 70 x 16 mm (4.57 x 2.75 x 0.63 in.) 180 x 93 x 25 mm (7.08 x 3.66 x 0.98 in.)	
Weight	91 g (3.2 oz.)	173 g (5.7 oz.)
Temperature Operating: Storage:	-20...+60 °C (-4...+140 °F) -40...+85 °C (-40...+185 °F)	
Relative Humidity	5...95% non-condensing	
Atmosphere	<b>Important:</b> The module must not be installed in an area where the ambient atmosphere contains volatile or corrosive gas, vapors or dust. If the module is not going to be installed for a period of time, it must be stored in an area where it will not be exposed to a corrosive atmosphere.	
UV Radiation	The HIM is not UV rated.	
Vibration Operating: Non-Operating:	2.5 G at 5...2000 Hz 5 G at 5...2000 Hz	
Shock Operating: Non-Operating:	30 G peak acceleration, 11 (±1) ms pulse width 50 G peak acceleration, 11 (±1) ms pulse width	
UL c-UL CE RCM FCC ID IC	UL 61800-5-1 CAN / CSA C22.2 No. 274 EN61800-3, EN61800-5-1 EN61800-3 — —	

(1) NOTE: This is a product of category C2 according to IEC 61800-3. In a domestic environment this product may cause radio interference in which case supplementary mitigation measures may be required.

## Human Interface Module Kits

Description	Cat. No.
Bezel Kit for LCD HIMs, NEMA Type 1 <sup>(1)</sup>	20-HIM-B1
PowerFlex HIM Interface Cable, 1 m (39 in.) <sup>(2)</sup>	20-HIM-H10
Comm Option Cable Kit (Plug-Plug)	
0.33 m (1.1 ft)	1202-C03
1 m (3.3 ft)	1202-C10
3 m (9.8 ft)	1202-C30
9 m (29.5 ft)	1202-C90
Cable Kit (Plug-Socket) <sup>(3)</sup>	
0.33 m (1.1 ft)	1202-H03
1 m (3.3 ft)	1202-H10
3 m (9.8 ft)	1202-H30
9 m (29.5 ft)	1202-H90
DPI Cable Kit with Connectors, Tools and 100 m (328 ft) Cable	1202-CBL-KIT-100M
DPI Cable Connector Kit	1202-TB-KIT-SET
DPI/SCANport™ One to Two Port Splitter Cable	1203-S03

(1) Includes a 1202-C30 interface cable (3 m) for connection to drive.

(2) Required only when HIM is used as handheld or remote.

(3) Required in addition to 20-HIM-H10 for distances up to a total maximum of 10 m (32.8 ft).

## PowerFlex 750-Series Drives Option Kits

This table lists the PowerFlex 750-Series drives option kits.

### PowerFlex 750-Series Drives Option Kits

Cat. No.	Description		Frame Size	Publication
20-750-TAPS-XT	Auxiliary power supply	24V auxiliary power supply.	1...7	<a href="#">750-IN111</a>
20-750-DCBB3-F6	DC bus bar option kit	DC bus bars for 380...480V AC drives.	6	<a href="#">750-IN127</a>
20-750-DCBB3-F7			7	
20-750-DCFH-51	DC fuse holders (Qty. 2 holders)	DC fuse and fuse holder kits are recommended for short circuit protection of PowerFlex 755TS DC input drives installed in common bus applications.	1...4	<a href="#">750-IN121</a>
20-750-DCFH-NH1			1...7	
20-750-DCFH-NH2			5...7	
20-750-DCFH-NH3			5...7	
20-750-DCFUSE1-nnA	DC fuse kit (Qty. 2 fuses)	Use with 20-750-DCFH-51 fuse holder.	1...4	<a href="#">750-IN121</a>
20-750-DCFUSE3-nnA		Use with 20-750-DCFH-NH1 fuse holder.	1...4	
20-750-DCFUSE3S-nnnA			5...7	
20-750-DCFUSE5S-nnnA		Use with 20-750-DCFH-NH2 fuse holder.	5...7	
20-750-DCFUSE6S-nnnA		Use with 20-750-DCFH-NH3 fuse holder.	5...7	
20-750-EMC6-F6	EMC C3 option kit <sup>(1)</sup>	EMC plate for 380...480V AC drives.	6	<a href="#">750-IN124</a>
20-750-EMC6-F7			7	
20-750-TFLNG1-F2	Flange mount adapter kit	Converts Open Type drive to external heatsink (flange) with NEMA/UL Type 1 integrity backside. This kit is for use with IP20, NEMA/UL Type 0 drives and does not provide an airtight or watertight seal. Where an airtight or watertight seal is required (for example, contaminated, dirty, or wet environments), use a drive with an "F" enclosure option.	2	<a href="#">750-IN122</a>
20-750-TFLNG1-F3			3	
20-750-TFLNG1-F4			4	
20-750-TFLNG1-F5			5	
20-750-TFLNG1-F6		Converts Open Type drive to external heatsink (flange) with NEMA/UL Type 4X/12 integrity backside.	6	<a href="#">750-IN123</a>
20-750-TFLNG1-F7			7	
20-750-NEMA1-F1	NEMA/UL Type 1 option kit	Provides NEMA/UL Type 1 IEC 60529 IP20 rating.	1	<a href="#">750-IN008</a>
20-750-NEMA1-F2			2	
20-750-NEMA1-F3			3	
20-750-NEMA1-F4			4	
20-750-NEMA1-F5			5	
20-750-NEMA1-F6			6	
20-750-NEMA1-F7			7	
20-750-TNEMA1-F3	NEMA/UL Type 1 option kit - Frame 3	Provides NEMA/UL Type 1 IEC 60529 IP20 rating for 40 HP/30 kW ND frame 3 drives.	3	<a href="#">750-IN008</a>
20-750-ACTE1-F6	Power terminal extension	Allows connection of two parallel leads to the AC power terminals.	6	<a href="#">750-IN012</a>
20-750-PTG2-F6	Power terminal guard	Provides additional protection against contact with the power terminals.	6	<a href="#">750-IN126</a>
20-750-PTG1-F7			7	
20-750-TSTAM-CD-XT	Torque accuracy module	Precise torque control for PowerFlex 755TS drives.	2...7	<a href="#">750-IN120</a>

(1) EMC C3 brackets are factory installed on drive frames 2...5 and provided loose with frame 1 drives. Replacement EMC C3 bracket kits (SK-RT-EMC3-Fx) are also available. See the PowerFlex 755TS Products with TotalFORCE Control Installation Instructions, publication [750-IN119](#) for installation instructions.

## Communication Option Module Kits and Accessories

This section lists the communication option module kits and accessories.

### Communication Option Module Kits and Accessories

Cat. No.	Description (see <a href="#">page 247</a> for specifications)	Publication
20-750-CNETC <sup>(1)</sup>	Coaxial ControlNet option module	<a href="#">750COM-UM003</a>
20-750-DNET <sup>(1)</sup>	DeviceNet option module	<a href="#">750COM-UM002</a>
20-750-ENETR <sup>(1)</sup>	Dual-port EtherNet/IP option module	<a href="#">750COM-UM008</a>
20-750-PBUS	Series B PROFIBUS DPV1 option module	<a href="#">750COM-UM004</a>
20-750-PNET	Series B Single-port Profinet I/O option module	<a href="#">750COM-UM007</a>
20-750-PNET2P	Series B Dual-port Profinet I/O option module	<a href="#">750COM-UM007</a>
20-750-TLINK-XT 20-750-TLINK-FOC-5 20-750-TLINK-FOC-10 20-750-TLINK-FOC-50	Fast synchronized data transfer module	<a href="#">750COM-IN100</a>
1203-USB	Universal serial bus (USB) converter includes 2 m (6.6 ft) USB, 20-HIM-H10, and 22-HIM-H10 cables	<a href="#">DRIVES-UM001</a>
1786-TPS	ControlNet T-tap straight	<a href="#">1786-IN007</a>

(1) See Knowledgebase Technote [Explicit \(CIP\) Messaging PowerFlex 755T](#) for detailed information about using explicit messaging with option modules 20-750-CNETC, 20-750-DNET, or 20-750-ENETR.

### Environmental Specifications – Communication Option Module Kits

Attribute	Description
Temperature Operating Storage	-20...+60 °C (-4...+140 °F) -40...+85 °C (-40...+185 °F)
Relative humidity	5...95% noncondensing
Atmosphere	<b>IMPORTANT:</b> Do not install options modules without corrosive gas protection (-XT) in an area where the ambient atmosphere contains volatile or corrosive gas, vapors, or dust. If the option module is not going to be installed right away, store the option module in an area where it is not exposed to a corrosive atmosphere.

### Communication Option Kits and Accessories Specifications

Attribute	20-750-CNETC	20-750-DNET	20-750-ENETR	20-750-PBUS	20-750-PNET 20-750-PNET2P	1203-USB
Network Protocol Data rate	ControlNet 5 Mbps (fixed)	DeviceNet 125 Kbps, 250 Kbps, and 500 Kbps	EtherNet/IP 10/100 Mbps, Half/Full Duplex	PROFIBUS 9600 bps...12 Mbps (autobauds)	Profinet 10/100 Mbps	Universal Serial Bus (USB) 115.2 Kbps
Drive Protocol Data rates	DPI 500 Kbps	DPI 500 Kbps	DPI 500 Kbps	DPI 500 Kbps	DPI 500 Kbps	SCANport, DPI, or DSI 125, 125/500, 19.2 Kbps
Consumption Drive (DPI) Network	250 mA at 14V DC None	50 mA at 14V DC 60 mA at 24V DC	250 mA at 14V DC None	250 mA at 14V DC None	250 mA at 14V DC None	130 mA at 12V DC 170 mA at +5V DC (DSI)
Dimensions H x L x W mm (in)	68.0 x 150.0 x 26.0 (2.70 x 5.90 x 1.00)	68.0 x 150.0 x 26.0 (2.70 x 5.90 x 1.00)	68.0 x 150.0 x 26.0 (2.70 x 5.90 x 1.00)	16.0 x 130.0 x 83.0 (0.63 x 5.12 x 3.27)	16.0 x 130.0 x 83.0 (0.63 x 5.12 x 3.27)	103.5 x 73.4 x 23.6 (4.08 x 2.89 x 0.93)
Weight g (oz)	62 (2.1)	62 (2.1)	62 (2.1)	57 (2.0)	60 (2.0)	71 (2.5)
Compliance UL c-UL CE RCM	UL508C CAN/CSA C22.2 No. 14 EN61800-3 EN61800-3	UL508C CAN/CSA C22.2 No. 14 EN61800-3 EN61800-3	UL508C CAN/CSA C22.2 No. 14 EN61800-3 EN61800-3	UL508C CAN/ CSA C22.2 No.14 IEC61800-3 EN61800-3	UL508C CAN/CSA C22.2 No. 14 EN61800-3 EN61800-3	UL508C CAN/CSA C22.2 No. 14 — —

## Feedback Option Modules

This section lists the feedback option modules.

Cat. No.	Description
20-750-ENC-1 <sup>(1)</sup>	Incremental encoder
20-750-ENC-1-XT <sup>(1)</sup>	Incremental encoder with XT Corrosive Gas Protection
20-750-DENC-1 <sup>(1)</sup>	Dual incremental encoder
20-750-DENC-1-XT <sup>(1)</sup>	Dual incremental encoder with XT Corrosive Gas Protection
20-750-UFB-1 <sup>(2)</sup>	Universal feedback board (includes Stegmann, Heidenhain, SSI, Biss, 5V incremental)
20-750-UFB-1-XT <sup>(2)</sup>	Universal feedback board (includes Stegmann, Heidenhain, SSI, Biss, 5V incremental) with XT Corrosive Gas Protection

(1) Homing and registration functions are not supported when using this device with Studio 5000 Logix Designer® embedded motion instructions. To use the homing and registration functions, you must use the Universal Feedback Board (catalog number 20-750-UFB-1).

(2) Only PowerFlex 755 drives.

This table specifies which encoder type combinations work on a universal feedback board (UFB).

### Encoder Combinations Compatible with Universal Feedback Board

#### Encoder on Channel 0

	Encoder on Channel 0																			
	None	EnDat SC	Hiperface SC	BISS SC	SSI SC	EnDat FD ChX	EnDat FD ChY	BISS FD ChX	BISS FD ChY	SSI FD ChX	SSI FD ChY	SinCos only	Incmtl A B Z	Incmtl SC	LinTempo ChX	LinTempo ChY	LinStahl ChX	LinStahl ChY	Lin SSI ChX	Lin SSI ChY
None	C	C	C	C	C	C	C	C	C	C	C	C	C	C	C	C	C	C	C	C
EnDat SC	C	C	C	C	C	C	C	C	C	C	C	C	C	C	C	C	C	C	C	C
Hiperface SC	C	C	C	C	C	C	C	C	C	C	C	C	C	C	C	C	C	C	C	C
BISS SC	C	C	C	C	C	C	C	C	C	C	C	C	C	C	C	C	C	C	C	C
SSI SC	C	C	C	C	C	C	C	C	C	C	C	C	C	C	C	C	C	C	C	C
EnDat FD ChX	C	C	C	C	C	N	N	N	C	N	C	C	C	C	N	C	N	C	N	C
EnDat FD ChY	C	C	C	C	C	N	N	C	N	C	N	C	C	C	C	N	C	N	C	N
BISS FD ChX	C	C	C	C	C	N	C	N	N	N	C	C	C	C	N	C	N	C	N	C
BISS FD ChY	C	C	C	C	C	C	N	N	N	C	N	C	C	C	C	N	C	N	C	N
SSI FD ChX	C	C	C	C	C	N	C	N	N	N	C	C	C	C	N	C	N	C	N	C
SSI FD ChY	C	C	C	C	C	C	N	C	C	N	N	C	C	C	C	N	C	N	C	N
SinCos only	C	C	C	C	C	C	C	C	C	C	C	C	C	C	C	C	C	C	C	C
Incmtl A B Z	C	C	C	C	C	C	C	C	C	C	C	C	N	C	C	C	C	C	C	C
Incmtl SC	C	C	C	C	C	C	C	C	C	C	C	C	C	C	C	C	C	C	C	C
LinTempo ChX	C	C	C	C	C	N	C	N	C	N	C	C	C	C	N	C	N	C	N	C
LinTempo ChY	C	C	C	C	C	C	N	C	N	C	N	C	C	C	C	N	C	N	C	N
LinStahl ChX	C	C	C	C	C	N	C	N	C	N	C	C	C	C	N	C	N	C	N	C
LinStahl ChY	C	C	C	C	C	C	N	C	N	C	N	C	C	C	C	N	C	N	C	N
Lin SSI ChX	C	C	C	C	C	N	C	N	C	N	C	C	C	C	N	C	N	C	N	C
Lin SSI ChY	C	C	C	C	C	C	N	C	N	C	N	C	C	C	C	N	C	N	C	N

C	Compatible
N	Not compatible

## I/O Option Module Kits

This section lists the I/O option module kits.

Cat. No.	Description <sup>(1)</sup>	Publication
20-750-ATEX	ATEX Option Module with 1 Thermosensor Input Connection (requires 11-Series I/O Module below)	<a href="#">750-UM003</a>
20-750-1132C-2R	24V DC 11-Series I/O Module with 1 Analog In, 1 Analog Out, 3 Digital In and 2 Relay Outputs	<a href="#">750-IN11</a>
20-750-1133C-1R2T	24V DC 11-Series I/O Module with 1 Analog In, 1 Analog Out, 3 Digital In, 1 Relay and 2 Transistor Outputs	
20-750-1132D-2R	115V AC 11-Series I/O Module with 1 Analog In, 1 Analog Out, 3 Digital In and 2 Relay Outputs	
20-750-2262C-2R	24V DC 22-Series I/O Module with 2 Analog In, 2 Analog Out, 6 Digital In and 2 Relay Outputs	
20-750-2262C-2R-XT	24V DC 22-Series I/O Module with 2 Analog In, 2 Analog Out, 6 Digital In and 2 Relay Outputs with XT Corrosive Gas Protection	
20-750-2262D-2R	115V AC 22-Series I/O Module with 2 Analog In, 2 Analog Out, 6 Digital In and 2 Relay Outputs	
20-750-2262D-2R-XT	115V AC 22-Series I/O Module with 2 Analog In, 2 Analog Out, 6 Digital In and 2 Relay Outputs with XT Corrosive Gas Protection	
20-750-2263C-1R2T	24V DC 22-Series I/O Module with 2 Analog In, 2 Analog Out, 6 Digital In, 3 Digital Out, 1 Relay and 2 Transistor Outputs	
20-750-2263C-1R2T-XT	24V DC 22-Series I/O Module with 2 Analog In, 2 Analog Out, 6 Digital In, 3 Digital Out, 1 Relay and 2 Transistor Outputs with XT Corrosive Gas Protection	

(1) I/O option module kits are not allowed in CIP motion mode.

## Safety Option Modules

This section lists the safety option module kits.

Cat. No. <sup>(1)</sup>	Description	Publication
20-750-S	Safe Torque Off	<a href="#">750-UM002</a>
20-750-S-XT	Safe Torque Off with XT Corrosive Gas Protection	
20-750-S1 <sup>(2)</sup>	Safe Speed Monitor	<a href="#">750-RM001</a>
20-750-S1-XT <sup>(2)</sup>	Safe Speed Monitor with XT Corrosive Gas Protection	
20-750-S3	Integrated Safety - Safe Torque Off	<a href="#">750-UM004</a>
20-750-S3-XT	Integrated Safety - Safe Torque Off with XT Corrosive Gas Protection	
20-750-S4	Network Safe Speed Monitor	<a href="#">750-UM005</a>
20-750-S4-XT	Network Safe Speed Monitor with XT Corrosive Gas Protection	

(1) Drive can accommodate only one option.

(2) Requires the dual incremental encoder or universal feedback option.

Safe Torque Off is ideal for safety related applications requiring removal of rotational power to the motor without shutting down the drive. Safe Torque Off functionality offers the benefit of quick start-up after a demand on the safety system and helps reduce wear from repetitive start-up and provides safety ratings up to and including SIL CL3, PLe, and Category 3.

In applications where the speed needs to be controlled and monitored, the Safe-Speed Monitor option combines Safe Torque Off capability with integrated safety relay functionality and the Safe-Speed Control technology in one hardware option to provide safety ratings up to and including SIL CL3, PLe, and Category 4.

With the Safe Speed Monitor option you can safely monitor and control the speed of your application which allows operators to perform process or maintenance work without stopping the machine.

Note that PowerFlex 755TS products can accommodate only one option.

## Specifications - PowerFlex 750-Series Safety Options

Attribute	Safe Torque Off, 20-750-S	Safe Speed Monitor, 20-750-S1
Standards	IEC/EN60204-1, ISO13489-1, IEC 61508, IEC 61800-5-2	IEC/EN60204-1, ISO12100, IEC 61508, IEC 61800-5-2
Safety Category	Cat. 3 and PL(e) per EN ISO 13849-1; SIL CL3 per IEC 61508 and EN 62061	Cat. 4 and PL(e) per EN ISO 13849-1; SIL CL3 per IEC 61508 and EN 62061
Power Supply (user I/O)	24V DC $\pm 10\%$ , 0.8...1.1 x rated voltage <sup>(3)</sup> PELV or SELV	
Power Consumption	4.4 W	36 W
Safety Enable (SE+, SE-)	24V DC, 22 mA, short-circuit protected	–
Safety Power (SP+, SP-)	24V DC, 35 mA, short-circuit protected	–
SLS Outputs (68, 78)	–	24V DC, 50 mA, short-circuit protected
SS Outputs (34, 44)	–	24V DC, 50 mA, short-circuit protected
Door Control Outputs (51, 52)	–	24V DC, short-circuit protected, 0.75 A bipolar (Power to Release/ Power to Lock) configuration. 20 mA, cascading (2Ch Source) configuration.
Pulse Outputs (S11, S21)	–	24V DC, 50 mA, short-circuit protected
Pulse Inputs (S12, S22, S32, S42, S52, S62, S72, S82, X32, X42)	–	5 mA per input, max
Input ON Voltage, Minimum	24V DC $\pm 10\%$ , 21.6...26.4V DC	15V
Input OFF Voltage, Maximum	5V	5V
Input OFF Current, Maximum	2.5 mA @ 5V DC	2 mA
Input-to-Output Response Time (SS_In, SLS_In, DM_In, ESM_In, LM_In)	–	20 ms
Overspeed Response Time	–	User-configurable
Inputs (S34)	–	5 mA per input, max
Conductor Size <sup>(1)</sup>	0.3...0.8 mm <sup>2</sup> (28...18 AWG)	0.25...2.5 mm <sup>2</sup> (24...14 AWG)
Strip Length	10 mm (0.39 in.)	6 mm (0.25 in.)
Terminal Screw Torque	–	0.2...0.25 N•m (1.8...2.2 lb•in)
Certification <sup>(2)</sup>		
c-UL-us	UL Listed, certified for US and Canada.	
CE	European Union 2004/108/EC EMC Directive, and EU 2006/42/EC Machinery Directive EN 61800-3; categories C2 and C3 EN 62061; EM Immunity EN ISO 13849-1 EN ISO 13849-2 EN 61800-5-1 EN 61800-5-2 EN 61508 Parts 1-7	
C-Tick	Australian Radiocommunications Act, compliant with: EN 61800-3; categories C2 and C3	
TÜV	TÜV Certified for Functional Safety: up to SIL CL3, according to EN 61800-5-2, EN 61508, and EN 62061; up to Performance Level PL(e) and Category 3, according to EN ISO 13849-1; when used as described.	TÜV Certified for Functional Safety: up to SIL CL3, according to EN 61800-5-2, EN 61508, and EN 62061; up to Performance Level PL(e) and Category 4, according to EN ISO 13849-1; when used as described.

(1) See the Industrial Automation Wiring and Grounding Guidelines, publication [1770-4.1](#).

(2) When product is marked.

(3) Safety outputs need additional fuse for reverse voltage protection of the control circuit. Install a 6 A slow-blow or 10 A fast-acting fuse.

## Specifications - Network Safety Options

Attribute	Network Safe Torque Off, 20-750-S3	Network Safe Speed Monitor, 20-750-S4
Standards	EN 60204-1, IEC 61508, EN 61800-3, EN 61800-5-1, EN 61800-5-2, EN 62061, EN ISO 13849	EN 60204-1, IEC 61508, EN 61800-3, EN 61800-5-1, EN 61800-5-2, EN 62061, EN ISO 13849-1
Safety category	Cat. 3 and PLe per ISO 13849-1; SIL CL3 per IEC 61508 and EN 62061	Cat. 4 and PLe per EN ISO 13849-1; SIL 3 per IEC 61508 and SIL CL3 per EN IEC 62061
Power supply (user I/O)	24V DC $\pm 10\%$ , 0.8...1.1 x rated voltage <sup>(1)</sup> PELV or SELV	24V DC $\pm 10\%$ , 0.8...1.1 x rated voltage <sup>(1)</sup> PELV or SELV
Input type	Current sinking	Current sinking
Voltage, on-state input	11...30V, 3.5 mA DC	11...30V DC
Voltage, off-state input, max	5V, 3.5 mA DC	-3...+5V DC
Current, on-state input, min	3.3 mA	2 mA
Current, off-state, max	1.3 mA	1.5 mA
IEC 61131-2 (input type)	Type 3	Type 3
Conductor type	Multi-conductor shielded cable	Multi-conductor shielded cable
Conductor size <sup>(2)</sup>	0.3...0.8 mm <sup>2</sup> (28...18 AWG)	0.3...0.8 mm <sup>2</sup> (28...18 AWG)
Strip length	10 mm (0.39 in.)	10 mm (0.39 in.)

(1) Safety outputs need additional fuse for reverse voltage protection of the control circuit. Install a 6 A slow-blow or 10 A fast-acting fuse.

(2) See the Industrial Automation Wiring and Grounding Guidelines, publication [1770-4.1](#).

## Internal Dynamic Brake Resistor Kits

These resistors have a limited duty cycle. To determine whether an internal resistor is sufficient for your application, see the PowerFlex Dynamic Braking Resistor Calculator Application Technique, publication [PFLEX-AT001](#). An external resistor can be required.

Cat. No.	Drive Input Voltage	Frame	Rating (ND kW)	Rating (ND Hp)	Brake Resistance
20-750-DB1-D1	200...240V AC	1	0.37...0.75	0.5...1	62 $\Omega$
20-750-DB1-B1			1.5...4	2...5	22 $\Omega$
20-750-DB1-B2		2	0.37...5.5	0.5...7.5	22 $\Omega$
20-750-DB1-D1A	380...480V AC	1	0.75...2.2	1...3	115 $\Omega$
20-750-DB1-D1			4...7.5	5...10	62 $\Omega$
20-750-DB1-D2		2	0.75...11	1...15	62 $\Omega$

## Terminators

This table lists the terminators.

Cat. No.	Description <sup>(1)</sup>
1204-TFA1	For use with 3.7 kW (5 Hp) and lower drives.
1204-TFB2	For use with 1.5 kW (2 Hp) and higher drives.

(1) For selection information, see Appendix A of the Wiring and Grounding Guidelines for Pulse Width Modulated (PWM) AC Drives, publication [DRIVES-IN001](#).

## Reflected Wave Reduction Modules with Common Mode Choke

This table lists the reflected wave reduction module with common mode choke.

Cat. No.	Description <sup>(1)</sup>
1204-RWC-17-A	17 A with common mode choke

(1) For selection information, see Appendix A of the Wiring and Grounding Guidelines for Pulse Width Modulated (PWM) AC Drives, publication [DRIVES-IN001](#).

## Reflected Wave Reduction Modules

This table lists the reflected wave reduction modules.

ND kW	ND Hp	Cat. No.	
		380...480V AC	600V AC
4	5	1321-RWR8-DP	1321-RWR8-EP
5.5	7.5	1321-RWR12-DP	1321-RWR12-EP
7.5	10	1321-RWR18-DP	1321-RWR18-EP
11	15	1321-RWR25-DP	1321-RWR25-EP
15	20	1321-RWR35-DP	1321-RWR35-EP
18.5	25	1321-RWR35-DP	1321-RWR35-EP
22	30	1321-RWR45-DP	1321-RWR45-EP
30	40	1321-RWR55-DP	1321-RWR55-EP
37	50	1321-RWR80-DP	1321-RWR80-EP
45	60	1321-RWR80-DP	1321-RWR80-EP
55	75	1321-RWR100-DP	1321-RWR100-EP
75	100	1321-RWR130-DP	1321-RWR130-EP
90	125	1321-RWR160-DP	1321-RWR160-EP
110	150	1321-RWR200-DP	1321-RWR200-EP
132	200	1321-RWR250-DP	1321-RWR250-EP
187	250	1321-RWR320-DP	1321-RWR320-EP

# Isolation Transformers

This section provides information for isolation transformers.

**Figure 1 - IP32, NEMA/UL Type 3R Standalone, 4...6% Nominal Impedance**

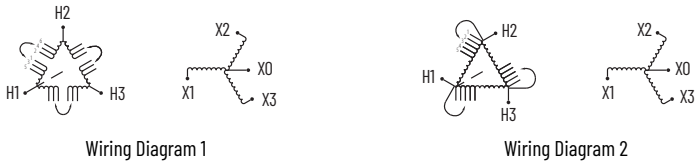

## 230V, 60 Hz, Three-phase, 230V Primary and 230V Secondary

Motor Rating		Wiring Diagram	Cat. No.
kW	Hp		
0.37	0.5	1	1321-3TW005-AA
0.75	1	1	1321-3TW005-AA
1.5	2	1	1321-3TW005-AA
2.2	3	1	1321-3TW005-AA
4	5	2	1321-3TW040-AA
5.5	7.5	2	1321-3TW040-AA
7.5	10	2	1321-3TW040-AA
11	15	2	1321-3TW040-AA
15	20	2	1321-3TW040-AA
18.5	25	2	1321-3TW040-AA

Motor Rating		Wiring Diagram	Cat. No.
kW	Hp		
22	30	2	1321-3TH040-AA
30	40	2	1321-3TH051-AA
37	50	2	1321-3TH063-AA
45	60	2	1321-3TH063-AA
55	75	2	1321-3TH093-AA
66	100	2	1321-3TH093-AA
90	125	2	1321-3TH145-AA
110	150	2	1321-3TH145-AA
132	200	1	1321-3TH175-BB

## 460V, 60 Hz, Three-phase, 460V Primary and 460V Secondary

Motor Rating		Wiring Diagram	Cat. No.
kW	Hp		
0.75	1	1	1321-3TW005-BB
1.5	2	1	1321-3TW005-BB
2.2	3	1	1321-3TW005-BB
22	30	2	1321-3TW040-BB
30	40	2	1321-3TW051-BB
37	50	2	1321-3TH063-BB
45	60	2	1321-3TH075-BB
55	75	2	1321-3TH093-BB
75	100	2	1321-3TH118-BB
90	125	2	1321-3TH145-BB

Motor Rating		Wiring Diagram	Cat. No.
kW	Hp		
110	150	2	1321-3TH175-BB
149	200	2	1321-3TH220-BB
187	250	2	1321-3TH275-BB
224	300	2	1321-3TH330-BB
261	350	1	1321-3TH440-BB
298	400	1	1321-3TH440-BB
336	450	1	1321-3TH550-BB
373	500	1	1321-3TH550-BB
448	600	1	1321-3TH660-BB
485	650	1	—

Motor Rating		Wiring Diagram	Cat. No.
kW	Hp		
522	700	1	1321-3TH770-BB
560	750	1	1321-3TH770-BB
597	800	1	1321-3TH880-BB
671	900	900 kVA	A 1321 isolation transformer solution is not available. Approximate drive kVA is shown at left.
746	1000	1000 kVA	
821	1100	1200 kVA	
933	1250	1200 kVA	
1007	1350	1300 kVA	
1119	1500	1500 kVA	
1492	2000	2000 kVA	

## 575V, 60 Hz, Three-phase, 575V Primary, and 575V Secondary

Motor Rating		Wiring Diagram	Cat. No.
kW	Hp		
0.75	1	1	1321-3TW005-CC
1.5	2	1	1321-3TW005-CC
2.2	3	1	1321-3TW005-CC
22	30	2	1321-3TW040-CC
30	40	2	1321-3TW051-CC
37	50	2	1321-3TH063-CC
45	60	2	1321-3TH075-CC
55	75	2	1321-3TH093-CC
75	100	1	1321-3TH118-CC

Motor Rating		Wiring Diagram	Cat. No.
kW	Hp		
90	125	1	1321-3TH145-CC
110	150	1	1321-3TH175-CC
149	200	1	1321-3TH220-CC
187	250	1	1321-3TH275-CC
224	300	1	1321-3TH330-CC
261	350	1	1321-3TH440-CC
298	400	1	1321-3TH550-CC
336	450	1	1321-3TH550-CC
373	500	1	1321-3TH660-CC

Motor Rating		Wiring Diagram	Cat. No.
kW	Hp		
410	550	1	1321-3TH660-CC
448	600	1	1321-3TH770-CC
522	700	1	1321-3TH770-CC
597	800	1	1321-3TH880-CC
671	900	950 kVA	A 1321 isolation transformer solution is not available. Approximate drive kVA is shown at left.
709	950	1000 kVA	
746	1000	1100 kVA	
895	1200	1200 kVA	
1119	1500	1500 kVA	

## Input and Output Reactors

This section provides information for input and output reactors.

### 200...240V, 60 Hz, Three-phase, 3% Impedance

kW	Hp	Duty	Input Line Reactor		Output Load Reactor	
			IP00 (Open Style)	IP11 (NEMA/UL Type 1)	IP00 (Open Style)	IP11 (NEMA/UL Type 1)
			Cat. No.	Cat. No.	Cat. No.	Cat. No.
0.37	0.5	Normal	1321-3R2-D	1321-3RA2-D	1321-3R2-D	1321-3RA2-D
		Heavy	1321-3R2-D	1321-3RA2-D	1321-3R4-A	1321-3RA4-A
0.75	1	Normal	1321-3R4-A	1321-3RA4-A	1321-3R4-A	1321-3RA4-B
		Heavy	1321-3R4-A	1321-3RA4-A	1321-3R8-A	1321-3RA8-A
1.5	2	Normal	1321-3R8-A	1321-3RA8-A	1321-3R8-A	1321-3RA8-A
		Heavy	1321-3R8-A	1321-3RA8-A	1321-3R12-A	1321-3RA12-A
2.2	3	Normal	1321-3R12-A	1321-3RA12-A	1321-3R12-A	1321-3RA12-A
		Heavy	1321-3R12-A	1321-3RA12-A	1321-3R18-A	1321-3RA18-A
4	5	Normal	1321-3R18-A	1321-3RA18-A	1321-3R18-A	1321-3RA18-A
		Heavy	1321-3R18-A	1321-3RA18-A	1321-3R25-A	1321-3RA25-A
5.5	7.5	Normal	1321-3R25-A	1321-3RA25-A	1321-3R25-A	1321-3RA25-A
		Heavy	1321-3R25-A	1321-3RA25-A	1321-3R35-A	1321-3RA35-A
7.5	10	Normal	1321-3R35-A	1321-3RA35-A	1321-3R35-A	1321-3RA35-A
		Heavy	1321-3R35-A	1321-3RA35-A	1321-3R45-A	1321-3RA45-A
11	15	Normal	1321-3R45-A	1321-3RA45-A	1321-3R45-A	1321-3RA45-A
		Heavy	1321-3R45-A	1321-3RA45-A	1321-3R55-A	1321-3RA55-A
15	20	Normal	1321-3R55-A	1321-3RA55-A	1321-3R55-A	1321-3RA55-A
		Heavy	1321-3R55-A	1321-3RA55-A	1321-3R80-A	1321-3RA80-A
18.5	25	Normal	1321-3R80-A	1321-3RA80-A	1321-3R80-A	1321-3RA80-A
		Heavy	1321-3R80-A	1321-3RA80-A	1321-3R80-A	1321-3RA80-A

**200...240V, 60 Hz, Three-phase, 3% Impedance (Continued)**

kW	Hp	Duty	Input Line Reactor		Output Load Reactor	
			IP00 (Open Style)	IPT1 (NEMA/UL Type 1)	IP00 (Open Style)	IPT1 (NEMA/UL Type 1)
			Cat. No.	Cat. No.	Cat. No.	Cat. No.
22	30	Normal	1321-3R80-A	1321-3RA80-A	1321-3R80-A	1321-3RA80-A
		Heavy	1321-3R80-A	1321-3RA80-A	1321-3R100-A	1321-3RA100-A
30	40	Normal	1321-3R100-A	1321-3RA100-A	1321-3R100-A	1321-3RA100-A
		Heavy	1321-3R100-A	1321-3RA100-A	1321-3R130-A	1321-3RA130-A
37	50	Normal	1321-3R130-A	1321-3RA130-A	1321-3R130-A	1321-3RA130-A
		Heavy	1321-3R130-A	1321-3RA130-A	1321-3R160-A	1321-3RA160-A
45	60	Normal	1321-3R160-A	1321-3RA160-A	1321-3R160-A	1321-3RA160-A
		Heavy	1321-3R160-A	1321-3RA160-A	1321-3R200-A	1321-3RA200-A
55	75	Normal	1321-3R200-A	1321-3RA200-A	1321-3R200-A	1321-3RA200-A
		Heavy	1321-3R200-A	1321-3RA200-A	1321-3RB320-A	1321-3RAB320-A
66	100	Normal	1321-3RB320-A	1321-3RAB320-A	1321-3RB320-A	1321-3RAB320-A
		Heavy	1321-3RB320-A	1321-3RAB320-A	1321-3RB320-A	1321-3RAB320-A
90	125	Normal	1321-3RB320-A	1321-3RAB320-A	1321-3RB320-A	1321-3RAB320-A
		Heavy	1321-3RB320-A	1321-3RAB320-A	1321-3RB400-A	1321-3RAB400-A
110	150	Normal	1321-3RB400-A	1321-3RAB400-A	1321-3RB400-A	1321-3RAB400-A
132	200	Normal	1321-3R500-A	1321-3RA500-A	1321-3R500-A	1321-3RA500-B

**200...240V, 60 Hz, Three-phase, 5% Impedance**

kW	Hp	Duty	Input Line Reactor		Output Load Reactor	
			IP00 (Open Style)	IPT1 (NEMA/UL Type 1)	IP00 (Open Style)	IPT1 (NEMA/UL Type 1)
			Cat. No.	Cat. No.	Cat. No.	Cat. No.
0.37	0.5	Normal	1321-3R2-A	1321-3RA2-A	1321-3R2-A	1321-3RA2-A
		Heavy	1321-3R2-A	1321-3RA2-A	1321-3R4-A	1321-3RA4-A
0.75	1	Normal	1321-3R4-B	1321-3RA4-B	1321-3R4-B	1321-3RA4-B
		Heavy	1321-3R4-B	1321-3RA4-B	1321-3R8-B	1321-3RA8-B
1.5	2	Normal	1321-3R8-B	1321-3RA8-B	1321-3R8-B	1321-3RA8-B
		Heavy	1321-3R8-B	1321-3RA8-B	1321-3R12-B	1321-3RA12-B
2.2	3	Normal	1321-3R12-B	1321-3RA12-B	1321-3R12-B	1321-3RA12-B
		Heavy	1321-3R12-B	1321-3RA12-B	1321-3R18-B	1321-3RA18-B
4	5	Normal	1321-3R18-B	1321-3RA18-B	1321-3R18-B	1321-3RA18-B
		Heavy	1321-3R18-B	1321-3RA18-B	1321-3R25-B	1321-3RA25-B
5.5	7.5	Normal	1321-3R25-B	1321-3RA25-B	1321-3R25-B	1321-3RA25-B
		Heavy	1321-3R25-B	1321-3RA25-B	1321-3R35-B	1321-3RA35-B
7.5	10	Normal	1321-3R35-B	1321-3RA35-B	1321-3R35-B	1321-3RA35-B
		Heavy	1321-3R35-B	1321-3RA35-B	1321-3R45-B	1321-3RA45-B
11	15	Normal	1321-3R45-B	1321-3RA45-B	1321-3R45-B	1321-3RA45-B
		Heavy	1321-3R45-B	1321-3RA45-B	1321-3R55-B	1321-3RA55-B

**200...240V, 60 Hz, Three-phase, 5% Impedance (Continued)**

kW	Hp	Duty	Input Line Reactor		Output Load Reactor	
			IP00 (Open Style)	IP11 (NEMA/UL Type 1)	IP00 (Open Style)	IP11 (NEMA/UL Type 1)
			Cat. No.	Cat. No.	Cat. No.	Cat. No.
15	20	Normal	1321-3R55-B	1321-3RA55-B	1321-3R55-B	1321-3RA55-B
		Heavy	1321-3R55-B	1321-3RA55-B	1321-3R80-B	1321-3RA80-B
18.5	25	Normal	1321-3R80-B	1321-3RA80-B	1321-3R80-B	1321-3RA80-B
		Heavy	1321-3R80-B	1321-3RA80-B	1321-3R80-B	1321-3RA80-B
22	30	Normal	1321-3R80-B	1321-3RA80-B	1321-3R80-B	1321-3RA80-B
		Heavy	1321-3R80-B	1321-3RA80-B	1321-3R100-B	1321-3RA100-B
30	40	Normal	1321-3R100-B	1321-3RA100-B	1321-3R100-B	1321-3RA100-B
		Heavy	1321-3R100-B	1321-3RA100-B	1321-3R130-B	1321-3RA130-B
37	50	Normal	1321-3R130-B	1321-3RA130-B	1321-3R130-B	1321-3RA130-B
		Heavy	1321-3R130-B	1321-3RA130-B	1321-3R160-B	1321-3RA160-B
45	60	Normal	1321-3R160-B	1321-3RA160-B	1321-3R160-B	1321-3RA160-B
		Heavy	1321-3R160-B	1321-3RA160-B	1321-3R200-B	1321-3RA200-B
55	75	Normal	1321-3R200-B	1321-3RA200-B	1321-3R200-B	1321-3RA200-B
		Heavy	1321-3R200-B	1321-3RA200-B	1321-3RB320-B	1321-3RAB320-B
66	100	Normal	1321-3RB320-B	1321-3RAB320-B	1321-3RB320-B	1321-3RAB320-B
		Heavy	1321-3RB320-B	1321-3RAB320-B	1321-3RB320-B	1321-3RAB320-B
90	125	Normal	1321-3RB320-B	1321-3RAB320-B	1321-3RB320-B	1321-3RAB320-B
		Heavy	1321-3RB320-B	1321-3RAB320-B	1321-3RB400-B	1321-3RAB400-B
110	150	Normal	1321-3RB400-B	1321-3RAB400-B	1321-3RB400-B	1321-3RAB400-B
132	200	Normal	1321-3R500-B	1321-3RA500-B	1321-3R500-B	1321-3RA500-B

**380...480V, 50/60 Hz, Three-phase, 3% Impedance**

kW	Hp	Duty	Input Line Reactor		Output Load Reactor	
			IP00 (Open Style)	IP11 (NEMA/UL Type 1)	IP00 (Open Style)	IP11 (NEMA/UL Type 1)
			Cat. No.	Cat. No.	Cat. No.	Cat. No.
0.75	1	Normal	1321-3R2-A	1321-3RA2-A	1321-3R2-A	1321-3RA2-A
1.1	1.5	Heavy	1321-3R4-C	1321-3RA4-C	1321-3R4-B	1321-3RA4-B
1.5	2	Normal	1321-3R4-B	1321-3RA4-B	1321-3R4-B	1321-3RA4-B
		Heavy	1321-3R4-B	1321-3RA4-B	1321-3R8-C	1321-3RA8-C
2.2	3	Normal	1321-3R8-C	1321-3RA8-C	1321-3R8-C	1321-3RA8-C
		Heavy	1321-3R8-C	1321-3RA8-C	1321-3R8-B	1321-3RA8-B
4	5	Normal	1321-3R8-B	1321-3RA8-B	1321-3R8-B	1321-3RA8-B
		Heavy	1321-3R8-B	1321-3RA8-B	1321-3R12-B	1321-3RA12-B
5.5	7.5	Normal	1321-3R12-B	1321-3RA12-B	1321-3R12-B	1321-3RA12-B
		Heavy	1321-3R12-B	1321-3RA12-B	1321-3R18-B	1321-3RA18-B
7.5	10	Normal	1321-3R18-B	1321-3RA18-B	1321-3R18-B	1321-3RA18-B
		Heavy	1321-3R18-B	1321-3RA18-B	1321-3R25-B	1321-3RA25-B

**380...480V, 50/60 Hz, Three-phase, 3% Impedance (Continued)**

kW	Hp	Duty	Input Line Reactor		Output Load Reactor	
			IP00 (Open Style)	IP11 (NEMA/UL Type 1)	IP00 (Open Style)	IP11 (NEMA/UL Type 1)
			Cat. No.	Cat. No.	Cat. No.	Cat. No.
11	15	Normal	1321-3R25-B	1321-3RA25-B	1321-3R25-B	1321-3RA25-B
		Heavy	1321-3R25-B	1321-3RA25-B	1321-3R25-B	1321-3RA25-B
15	20	Normal	1321-3R35-B	1321-3RA35-B	1321-3R25-B	1321-3RA25-B
		Heavy	1321-3R35-B	1321-3RA35-B	1321-3R35-B	1321-3RA35-B
18.5	25	Normal	1321-3R35-B	1321-3RA35-B	1321-3R35-B	1321-3RA35-B
		Heavy	1321-3R35-B	1321-3RA35-B	1321-3R45-B	1321-3RA45-B
22	30	Normal	1321-3R45-B	1321-3RA45-B	1321-3R45-B	1321-3RA45-B
		Heavy	1321-3R45-B	1321-3RA45-B	1321-3R55-B	1321-3RA55-B
30	40	Normal	1321-3R55-B	1321-3RA55-B	1321-3R55-B	1321-3RA55-B
		Heavy	1321-3R55-B	1321-3RA55-B	1321-3R80-B	1321-3RA80-B
37	50	Normal	1321-3R80-B	1321-3RA80-B	1321-3R80-B	1321-3RA80-B
		Heavy	1321-3R80-B	1321-3RA80-B	1321-3R80-B	1321-3RA80-B
45	60	Normal	1321-3R80-B	1321-3RA80-B	1321-3R80-B	1321-3RA80-B
		Heavy	1321-3R80-B	1321-3RA80-B	1321-3R80-B	1321-3RA80-B
55	75	Normal	1321-3R100-B	1321-3RA100-B	1321-3R100-B	1321-3RA100-B
		Heavy	1321-3R100-B	1321-3RA100-B	1321-3R100-B	1321-3RA100-B
75	100	Normal	1321-3R130-B	1321-3RA130-B	1321-3R130-B	1321-3RA130-B
		Heavy	1321-3R130-B	1321-3RA130-B	1321-3R130-B	1321-3RA130-B
90	125	Normal	1321-3R160-B	1321-3RA160-B	1321-3R160-B	1321-3RA160-B
		Heavy	1321-3R160-B	1321-3RA160-B	1321-3R160-B	1321-3RA160-B
110	150	Normal	1321-3R200-B	1321-3RA200-B	1321-3R200-C	1321-3RA200-C
		Heavy	1321-3R200-B	1321-3RA200-B	1321-3R200-C	1321-3RA200-C
—	200	Normal/Heavy	1321-3RB250-B	1321-3RAB250-B	1321-3RB250-B	1321-3RAB250-B
132	—	Normal/Heavy	1321-3RB320-B	1321-3RAB320-B	1321-3RB320-B	1321-3RAB320-B
160	250	Normal/Heavy	1321-3RB320-B	1321-3RAB320-B	1321-3RB320-B	1321-3RAB320-B
—	300	Normal/Heavy	1321-3RB400-B	1321-3RAB400-B	1321-3RB400-B	1321-3RAB400-B
200	—	Normal/Heavy	1321-3RB400-B	1321-3RAB400-B	1321-3RB400-B	1321-3RAB400-B
—	350	Normal/Heavy	1321-3R500-B	1321-3RA500-B	1321-3R500-B	1321-3RA500-B
250	—	Normal/Heavy	1321-3R500-B	1321-3RA500-B	1321-3R500-B	1321-3RA500-B
270	—	Normal/Heavy	1321-3R500-B	1321-3RA500-B	1321-3R500-B	1321-3RA500-B
—	400	Normal/Heavy	1321-3R500-B	1321-3RA500-B	1321-3R500-B	1321-3RA500-B

**380...480V, 50/60 Hz, Three-phase, 5% Impedance**

kW	Hp	Duty	Input Line Reactor		Output Load Reactor	
			IPO0 (Open Style)	IPT1 (NEMA/UL Type 1)	IPO0 (Open Style)	IPT1 (NEMA/UL Type 1)
			Cat. No.	Cat. No.	Cat. No.	Cat. No.
0.75	1	Normal	1321-3R2-B	1321-3RA2-B	1321-3R2-B	1321-3RA2-B
1.1	1.5	Heavy	1321-3R4-D	1321-3RA4-D	1321-3R4-D	1321-3RA4-D
1.5	2	Normal	1321-3R4-D	1321-3RA4-D	1321-3R4-D	1321-3RA4-D
		Heavy	1321-3R4-D	1321-3RA4-D	1321-3R8-D	1321-3RA8-D
2.2	3	Normal	1321-3R8-D	1321-3RA8-D	1321-3R8-D	1321-3RA8-D
		Heavy	1321-3R8-D	1321-3RA8-D	1321-3R8-C	1321-3RA8-C
4	5	Normal	1321-3R8-C	1321-3RA8-C	1321-3R8-C	1321-3RA8-C
		Heavy	1321-3R8-C	1321-3RA8-C	1321-3R12-C	1321-3RA12-C
5.5	7.5	Normal	1321-3R12-C	1321-3RA12-C	1321-3R12-C	1321-3RA12-C
		Heavy	1321-3R12-C	1321-3RA12-C	1321-3R18-C	1321-3RA18-C
7.5	10	Normal	1321-3R18-C	1321-3RA18-C	1321-3R18-C	1321-3RA18-C
		Heavy	1321-3R18-C	1321-3RA18-C	1321-3R25-C	1321-3RA25-C
11	15	Normal/Heavy	1321-3R25-C	1321-3RA25-C	1321-3R25-C	1321-3RA25-C
15	20	Normal	1321-3R35-C	1321-3RA35-C	1321-3R25-C	1321-3RA25-C
		Heavy	1321-3R35-C	1321-3RA35-C	1321-3R35-C	1321-3RA35-C
18.5	25	Normal	1321-3R35-C	1321-3RA35-C	1321-3R35-C	1321-3RA35-C
		Heavy	1321-3R35-C	1321-3RA35-C	1321-3R45-C	1321-3RA45-C
22	30	Normal	1321-3R45-C	1321-3RA45-C	1321-3R45-C	1321-3RA45-C
		Heavy	1321-3R45-C	1321-3RA45-C	1321-3R55-C	1321-3RA55-C
30	40	Normal	1321-3R55-C	1321-3RA55-C	1321-3R55-C	1321-3RA55-C
		Heavy	1321-3R55-C	1321-3RA55-C	1321-3R80-C	1321-3RA80-C
37	50	Normal	1321-3R80-C	1321-3RA80-C	1321-3R80-C	1321-3RA80-C
		Heavy	1321-3R80-C	1321-3RA80-C	1321-3R80-C	1321-3RA80-C
45	60	Normal/Heavy	1321-3R80-C	1321-3RA80-C	1321-3R80-C	1321-3RA80-C
55	75	Normal/Heavy	1321-3R100-C	1321-3RA100-C	1321-3R100-C	1321-3RA100-C
75	100	Normal/Heavy	1321-3R130-C	1321-3RA130-C	1321-3R130-C	1321-3RA130-C
90	125	Normal/Heavy	1321-3R160-C	1321-3RA160-C	1321-3R160-C	1321-3RA160-C
110	150	Normal	1321-3R200-C	1321-3RA200-C	1321-3R200-C	1321-3RA200-C
		Heavy	1321-3R200-C	1321-3RA200-C	1321-3R200-C	1321-3RA200-C
–	200	Normal/Heavy	1321-3RB250-C	1321-3RAB250-C	1321-3RB250-C	1321-3RAB250-C
132	–	Normal/Heavy	1321-3RB320-C	1321-3RAB320-C	1321-3RB320-C	1321-3RAB320-C
160	250	Normal/Heavy	1321-3RB320-C	1321-3RAB320-C	1321-3RB320-C	1321-3RAB320-C
–	300	Normal/Heavy	1321-3RB400-C	1321-3RAB400-C	1321-3RB400-C	1321-3RAB400-C
200	–	Normal/Heavy	1321-3RB400-C	1321-3RAB400-C	1321-3RB400-C	1321-3RAB400-C
–	350	Normal/Heavy	1321-3R500-C	1321-3RA500-C	1321-3R500-C	1321-3RA500-C
250	–	Normal/Heavy	1321-3R500-C	1321-3RA500-C	1321-3R500-C	1321-3RA500-C
270	–	Normal/Heavy	1321-3R500-C	1321-3RA500-C	1321-3R500-C	1321-3RA500-C
–	400	Light/Normal/Heavy	1321-3R500-C	1321-3RA500-C	1321-3R500-C	1321-3RA500-C

**380...480V, 50/60 Hz, Three-phase, 5% Impedance (Continued)**

kW	Hp	Duty	Input Line Reactor		Output Load Reactor	
			IPO0 (Open Style)	IPT1 (NEMA/UL Type 1)	IPO0 (Open Style)	IPT1 (NEMA/UL Type 1)
			Cat. No.	Cat. No.	Cat. No.	Cat. No.
315	—	Light/Normal/Heavy	1321-3R600-C	1321-3RA600-C	1321-3R600-C	1321-3RA600-C
336	450	Normal/Heavy	1321-3RA600-C	1321-3RA600-C	1321-3R500-C	1321-3RA500-C
—	450	Light/Normal/Heavy	1321-3R600-C	1321-3RA600-C	1321-3R600-C	1321-3RA600-C
355	—	Light/Normal/Heavy	1321-3R750-C	1321-3RA750-C	1321-3R750-C	1321-3RA750-C
—	500	Light	1321-3R600-C	1321-3RA600-C	1321-3R600-C	1321-3RA600-C
—	—	Normal/Heavy	1321-3R750-C	1321-3RA750-C	1321-3R750-C	1321-3RA750-C
400	—	Light/Heavy	1321-3R750-C	1321-3RA750-C	1321-3R750-C	1321-3RA750-C
—	—	Normal	1321-3R850-C	1321-3RA850-C	1321-3R850-C	1321-3RA850-C
—	600	Light/Normal/Heavy	1321-3R750-C	1321-3RA750-C	1321-3R750-C	1321-3RA750-C
450	—	Light	1321-3R850-C	1321-3RA850-C	1321-3R850-C	1321-3RA850-C
500	—	Normal/Heavy	1321-3R1000-C	1321-3RA1000-C	1321-3R1000-C	1321-3RA1000-C
—	650	Light	1321-3R850-C	1321-3RA850-C	1321-3R850-C	1321-3RA850-C
—	—	Normal	1321-3R750-C	1321-3RA750-C	1321-3R750-C	1321-3RA750-C
—	700	Light/Normal/Heavy	1321-3R850-C	1321-3RA850-C	1321-3R850-C	1321-3RA850-C
—	750	Heavy	1321-3R850-C	1321-3RA850-C	1321-3R850-C	1321-3RA850-C
—	800	Light/Normal/Heavy	1321-3R1000-C	1321-3RA1000-C	1321-3R1000-C	1321-3RA1000-C
560	—	Light/Normal/Heavy	1321-3R600-C <sup>(1)</sup>	1321-3RA600-C <sup>(1)</sup>	1321-3R600-C <sup>(1)</sup>	1321-3RA600-C <sup>(1)</sup>
630	—	Light/Normal/Heavy	1321-3R600-C <sup>(1)</sup>	1321-3RA600-C <sup>(1)</sup>	1321-3R600-C <sup>(1)</sup>	1321-3RA600-C <sup>(1)</sup>
—	900	Light/Normal/Heavy	1321-3R600-C <sup>(1)</sup>	1321-3RA600-C <sup>(1)</sup>	1321-3R600-C <sup>(1)</sup>	1321-3RA600-C <sup>(1)</sup>
710	—	Light/Normal/Heavy	1321-3R600-C <sup>(1)</sup>	1321-3RA600-C <sup>(1)</sup>	1321-3R600-C <sup>(1)</sup>	1321-3RA600-C <sup>(1)</sup>
—	1000	Light/Normal/Heavy	1321-3R600-C <sup>(1)</sup>	1321-3RA600-C <sup>(1)</sup>	1321-3R600-C <sup>(1)</sup>	1321-3RA600-C <sup>(1)</sup>
—	1100	Light/Normal	1321-3R750-C <sup>(1)</sup>	1321-3RA750-C <sup>(1)</sup>	1321-3R750-C <sup>(1)</sup>	1321-3RA750-C <sup>(1)</sup>
800	—	Light/Normal	1321-3R750-C <sup>(1)</sup>	1321-3RA750-C <sup>(1)</sup>	1321-3R750-C <sup>(1)</sup>	1321-3RA750-C <sup>(1)</sup>
850	—	Light/Normal	1321-3R750-C <sup>(1)</sup>	1321-3RA750-C <sup>(1)</sup>	1321-3R750-C <sup>(1)</sup>	1321-3RA750-C <sup>(1)</sup>
—	1250	Light/Normal	1321-3R750-C <sup>(1)</sup>	1321-3RA750-C <sup>(1)</sup>	1321-3R750-C <sup>(1)</sup>	1321-3RA750-C <sup>(1)</sup>
900	—	Light	1321-3R850-C <sup>(1)</sup>	1321-3RA850-C <sup>(1)</sup>	1321-3R850-C <sup>(1)</sup>	1321-3RA850-C <sup>(1)</sup>
—	1350	Light	1321-3R850-C <sup>(1)</sup>	1321-3RA850-C <sup>(1)</sup>	1321-3R850-C <sup>(1)</sup>	1321-3RA850-C <sup>(1)</sup>
—	1500	Light	1321-3R850-C <sup>(2)</sup>	1321-3RA850-C <sup>(2)</sup>	1321-3R850-C <sup>(2)</sup>	1321-3RA850-C <sup>(2)</sup>
1000	—	Light	1321-3R850-C <sup>(2)</sup>	1321-3RA850-C <sup>(2)</sup>	1321-3R850-C <sup>(2)</sup>	1321-3RA850-C <sup>(2)</sup>
—	2000	Light	1321-3R850-C <sup>(2)</sup>	1321-3RA850-C <sup>(2)</sup>	1321-3R850-C <sup>(2)</sup>	1321-3RA850-C <sup>(2)</sup>
1400	—	Light	1321-3R850-C <sup>(2)</sup>	1321-3RA850-C <sup>(2)</sup>	1321-3R850-C <sup>(2)</sup>	1321-3RA850-C <sup>(2)</sup>

(1) Requires two reactors that are wired in parallel.  
(2) Requires three reactors that are wired in parallel.

**600...690V, 50/60 Hz, Three-phase, 3% Impedance**

kW	Hp	Duty	Input Line Reactor		Output Load Reactor	
			IPO0 (Open Style)	IPT1 (NEMA/UL Type 1)	IPO0 (Open Style)	IPT1 (NEMA/UL Type 1)
			Cat. No.	Cat. No.	Cat. No.	Cat. No.
–	0.5	Heavy	1321-3R1-C	1321-3RA1-C	1321-3R1-C	1321-3RA1-C
–	1	Normal	1321-3R2-B	1321-3RA2-B	1321-3R2-A	1321-3RA2-B
		Heavy	1321-3R2-B	1321-3RA2-B	1321-3R4-A	1321-3RA4-A
–	2	Normal	1321-3R4-D	1321-3RA4-D	1321-3R4-C	1321-3RA4-C
		Heavy	1321-3R4-C	1321-3RA4-C	1321-3R4-C	1321-3RA4-C
–	3	Normal/Heavy	1321-3R4-B	1321-3RA4-B	1321-3R4-B	1321-3RA4-B
–	5	Normal/Heavy	1321-3R8-C	1321-3RA8-C	1321-3R8-C	1321-3RA8-C
5.5	–	Heavy	1321-3R12-C	1321-3RA12-C	1321-3R12-C	1321-3RA12-C
–	7.5	Normal/Heavy	1321-3R12-B	1321-3RA12-B	1321-3R12-B	1321-3RA12-B
7.5	–	Normal	1321-3R12-B	1321-3RA12-B	1321-3R12-B	1321-3RA12-B
		Heavy	1321-3R12-C	1321-3RA12-C	1321-3R18-C	1321-3RA18-C
–	10	Normal	1321-3R12-B	1321-3RA12-B	1321-3R12-B	1321-3RA12-B
		Heavy	1321-3R12-B	1321-3RA12-B	1321-3R18-C	1321-3RA18-C
11	–	Normal/Heavy	1321-3R18-C	1321-3RA18-C	1321-3R18-C	1321-3RA18-C
–	15	Normal	1321-3R18-B	1321-3RA18-B	1321-3R18-B	1321-3RA18-B
		Heavy	1321-3R25-B	1321-3RA25-B	1321-3R25-B	1321-3RA25-B
15	–	Normal/Heavy	1321-3R25-C	1321-3RA25-C	1321-3R25-C	1321-3RA25-C
–	20	Normal	1321-3R25-B	1321-3RA25-B	1321-3R25-B	1321-3RA25-B
		Heavy	1321-3R35-B	1321-3RA35-B	1321-3R35-B	1321-3RA35-B
18.5	–	Normal/Heavy	1321-3R25-C	1321-3RA25-C	1321-3R25-C	1321-3RA25-C
–	25	Normal	1321-3R25-B	1321-3RA25-B	1321-3R35-B	1321-3RA35-B
22	–	Normal/Heavy	1321-3R35-C	1321-3RA35-C	1321-3R35-C	1321-3RA35-C
–	30	Normal/Heavy	1321-3R35-B	1321-3RA35-B	1321-3R35-B	1321-3RA35-B
30	–	Normal/Heavy	1321-3R35-C	1321-3RA35-C	1321-3R35-C	1321-3RA35-C
–	40	Normal/Heavy	1321-3R45-B	1321-3RA45-B	1321-3R45-B	1321-3RA45-B
37	–	Normal/Heavy	1321-3R45-B	1321-3RA45-B	1321-3R55-C	1321-3RA55-C
–	50	Normal/Heavy	1321-3R55-B	1321-3RA55-B	1321-3R55-B	1321-3RA55-B
45	–	Normal/Heavy	1321-3R55-B	1321-3RA55-B	1321-3R55-B	1321-3RA55-B
–	60	Normal/Heavy	1321-3R80-B	1321-3RA80-B	1321-3R80-B	1321-3RA80-B
55	–	Normal	1321-3R80-C	1321-3RA80-C	1321-3R80-B	1321-3RA80-B
		Heavy	1321-3R80-B	1321-3RA80-B	1321-3R80-B	1321-3RA80-B
–	75	Normal/Heavy	1321-3R100-B	1321-3RA100-B	1321-3R100-B	1321-3RA100-B
75	–	Normal/Heavy	1321-3R80-B	1321-3RA80-B	1321-3R80-B	1321-3RA80-B
–	100	Normal	1321-3R100-B	1321-3RA100-B	1321-3R100-B	1321-3RA100-B
		Heavy	1321-3R100-B	1321-3RA100-B	1321-3R130-B	1321-3RA130-B
90	–	Normal/Heavy	1321-3R100-B	1321-3RA100-B	1321-3R100-B	1321-3RA100-B
–	125	Normal/Heavy	1321-3R130-B	1321-3RA130-B	1321-3R130-B	1321-3RA130-B
110	–	Normal/Heavy	1321-3R130-C	1321-3RA130-C	1321-3R130-C	1321-3RA130-C

**600...690V, 50/60 Hz, Three-phase, 3% Impedance (Continued)**

kW	Hp	Duty	Input Line Reactor		Output Load Reactor	
			IPO0 (Open Style)	IPT1 (NEMA/UL Type 1)	IPO0 (Open Style)	IPT1 (NEMA/UL Type 1)
			Cat. No.	Cat. No.	Cat. No.	Cat. No.
—	150	Normal	1321-3R160-B	1321-3RA160-B	1321-3R160-B	1321-3RA160-B
		Heavy	1321-3R200-B	1321-3RA200-B	1321-3R200-B	1321-3RA200-B
132	—	Normal/Heavy	1321-3R160-C	1321-3RA160-C	1321-3R160-C	1321-3RA160-C
—	200	Normal/Heavy	1321-3R200-B	1321-3RA200-B	1321-3R200-B	1321-3RA200-B
160	—	Normal	1321-3R160-C	1321-3RA160-C	1321-3R160-C	1321-3RA160-C
		Heavy	1321-3R200-C	1321-3RAB200-C	1321-3R200-C	1321-3RAB200-C
—	250	Normal/Heavy	1321-3R250-B	1321-3RA250-B	1321-3R250-B	1321-3RA250-B
—	300	Normal/Heavy	1321-3RB320-B	1321-3RAB320-B	1321-3RB320-B	1321-3RAB320-B
200	—	Normal	1321-3RB200-C	1321-3RAB200-C	1321-3RB200-C	1321-3RAB200-C
		Heavy	1321-3R200-C	1321-3RAB200-C	1321-3RB250-C	1321-3RAB250-C
		Heavy	1321-3R250-B	1321-3RA250-B	1321-3R250-B	1321-3RA250-B
—	350	Light/Normal/Heavy	1321-3RB400-B	1321-3RAB400-B	1321-3RB400-B	1321-3RAB400-B
250	—	Normal	1321-3RB250-C	1321-3RAB250-C	1321-3RB250-C	1321-3RAB250-C
		Normal/Heavy	1321-3RB320-B	1321-3RAB320-B	1321-3RB320-B	1321-3RAB320-B
—	400	Light/Normal/Heavy	1321-3RB400-B	1321-3RAB400-B	1321-3RB400-B	1321-3RAB400-B
300	—	Heavy	1321-3RB400-B	1321-3RAB400-B	1321-3RB400-B	1321-3RAB400-B
—	450	Light/Normal/Heavy	1321-3R500-B	1321-3RA500-B	1321-3R500-B	1321-3RA500-B
315	—	Light/Normal	1321-3RB400-B	1321-3RAB400-B	1321-3RB400-B	1321-3RAB400-B
—	500	Light/Normal	1321-3R600-B	1321-3RA600-B	1321-3R600-B	1321-3RA600-B
355	—	Light/Normal/Heavy	1321-3R500-B	1321-3RA500-B	1321-3R500-B	1321-3RA500-B
375	—	Heavy	1321-3R500-B	1321-3RA500-B	1321-3R500-B	1321-3RA500-B
400	—	Light/Normal/Heavy	1321-3R500-B	1321-3RA500-B	1321-3R500-B	1321-3RA500-B
450	—	Light/Normal	1321-3R600-B	1321-3RA600-B	1321-3R600-B	1321-3RA600-B
450	—	Heavy	1321-3R600-B	1321-3RA600-B	1321-3R600-B	1321-3RA600-B
500	—	Light/Normal	1321-3R600-B	1321-3RA600-B	1321-3R600-B	1321-3RA600-B
500	—	Heavy	1321-3R600-B	1321-3RA600-B	1321-3R600-B	1321-3RA600-B
530	—	Light	1321-3R600-B	1321-3RA600-B	1321-3R600-B	1321-3RA600-B
—	500	Heavy	1321-3R600-B	1321-3RA600-B	1321-3R600-B	1321-3RA600-B
—	550	Light	1321-3R600-B	1321-3RA600-B	1321-3R600-B	1321-3RA600-B
—	600	Normal/Heavy	1321-3R600-B	1321-3RA600-B	1321-3R600-B	1321-3RA600-B
—	700	Light/Normal/Heavy	1321-3R750-B	1321-3RA750-B	1321-3R750-B	1321-3RA750-B
560	—	Normal/Heavy	1321-3R750-B	1321-3RA750-B	1321-3R750-B	1321-3RA750-B
—	750	Heavy	1321-3R750-B	1321-3RA750-B	1321-3R750-B	1321-3RA750-B
630	—	Light/Normal/Heavy	1321-3R750-B	1321-3RA750-B	1321-3R750-B	1321-3RA750-B
—	800	Light/Normal/Heavy	1321-3R850-B	1321-3RA850-B	1321-3R850-B	1321-3RA850-B
710	—	Light/Normal/Heavy	1321-3R850-B	1321-3RA850-B	1321-3R850-B	1321-3RA850-B
—	900	Light/Normal/Heavy	1321-3R850-B	1321-3RA850-B	1321-3R850-B	1321-3RA850-B
750	—	Normal	1321-3R850-B	1321-3RA850-B	1321-3R850-B	1321-3RA850-B

### 600...690V, 50/60 Hz, Three-phase, 3% Impedance (Continued)

kW	Hp	Duty	Input Line Reactor		Output Load Reactor	
			IP00 (Open Style)	IP11 (NEMA/UL Type 1)	IP00 (Open Style)	IP11 (NEMA/UL Type 1)
			Cat. No.	Cat. No.	Cat. No.	Cat. No.
—	950	Light/Normal	1321-3R1000-B	1321-3RA1000-B	1321-3R1000-B	1321-3RA1000-B
800	—	Light/Normal/Heavy	1321-3R1000-B	1321-3RA1000-B	1321-3R1000-B	1321-3RA1000-B
—	1000	Light/Normal	1321-3R1000-B	1321-3RA1000-B	1321-3R1000-B	1321-3RA1000-B
850	—	Light	1321-3R1000-B	1321-3RA1000-B	1321-3R1000-B	1321-3RA1000-B
—	1100	Light	1321-3R600-B <sup>(1)</sup>	1321-3RA600-B <sup>(1)</sup>	1321-3R600-B <sup>(1)</sup>	1321-3RA600-B <sup>(1)</sup>
900	—	Light/Normal	1321-3R600-B <sup>(1)</sup>	1321-3RA600-B <sup>(1)</sup>	1321-3R600-B <sup>(1)</sup>	1321-3RA600-B <sup>(1)</sup>
1000	—	Light	1321-3R600-B <sup>(1)</sup>	1321-3RA600-B <sup>(1)</sup>	1321-3R600-B <sup>(1)</sup>	1321-3RA600-B <sup>(1)</sup>
1100	—	Light/Normal	1321-3R600-B <sup>(2)</sup>	1321-3RA600-B <sup>(2)</sup>	1321-3R600-B <sup>(2)</sup>	1321-3RA600-B <sup>(2)</sup>
—	1200	Light	1321-3R600-B <sup>(2)</sup>	1321-3RA600-B <sup>(2)</sup>	1321-3R600-B <sup>(2)</sup>	1321-3RA600-B <sup>(2)</sup>
1500	—	Light/Normal	1321-3R600-B <sup>(2)</sup>	1321-3RA600-B <sup>(2)</sup>	1321-3R600-B <sup>(2)</sup>	1321-3RA600-B <sup>(2)</sup>
—	1500	Light	1321-3R600-B <sup>(2)</sup>	1321-3RA600-B <sup>(2)</sup>	1321-3R600-B <sup>(2)</sup>	1321-3RA600-B <sup>(2)</sup>

(1) Requires two reactors that are wired in parallel.

(2) Requires three reactors that are wired in parallel.

### 600...690V, 50/60 Hz, Three-phase, 5% Impedance

kW	Hp	Duty	Input Line Reactor		Output Load Reactor	
			IP00 (Open Style)	IP11 (NEMA/UL Type 1)	IP00 (Open Style)	IP11 (NEMA/UL Type 1)
			Cat. No.	Cat. No.	Cat. No.	Cat. No.
—	0.5	Heavy	1321-3R1-C	1321-3RA1-C	1321-3R1-C	1321-3RA1-C
—	1	Normal	1321-3R2-C	1321-3RA2-C	1321-3R2-C	1321-3RA2-C
		Heavy	1321-3R4-D	1321-3RA4-D	1321-3R2-D	1321-3RA4-D
—	2	Normal/Heavy	1321-3R4-D	1321-3RA4-D	1321-3R4-D	1321-3RA4-D
—	3	Normal/Heavy	1321-3R4-D	1321-3RA4-D	1321-3R4-D	1321-3RA4-D
—	5	Normal/Heavy	1321-3R8-D	1321-3RA8-D	1321-3R8-D	1321-3RA8-D
5.5	—	Heavy	1321-3R12-C	1321-3RA12-C	1321-3R12-C	1321-3RA12-C
—	7.5	Normal/Heavy	1321-3R12-C	1321-3RA12-C	1321-3R12-C	1321-3RA12-C
7.5	—	Normal/Heavy	1321-3R12-C	1321-3RA12-C	1321-3R12-C	1321-3RA12-C
—	10	Normal/Heavy	1321-3R12-C	1321-3RA12-C	1321-3R12-C	1321-3RA12-C
11	—	Normal/Heavy	1321-3R18-C	1321-3RA18-C	1321-3R18-C	1321-3RA18-C
—	15	Normal/Heavy	1321-3R18-C	1321-3RA18-C	1321-3R18-C	1321-3RA18-C
15	—	Normal/Heavy	1321-3R25-C	1321-3RA25-C	1321-3R25-C	1321-3RA25-C
—	20	Normal/Heavy	1321-3R25-C	1321-3RA25-C	1321-3R25-C	1321-3RA25-C
18.5	—	Normal/Heavy	1321-3R25-C	1321-3RA25-C	1321-3R25-C	1321-3RA25-C
—	25	Normal/Heavy	1321-3R35-C	1321-3RA35-C	1321-3R35-C	1321-3RA35-C
22	—	Normal/Heavy	1321-3R35-C	1321-3RA35-C	1321-3R35-C	1321-3RA35-C
—	30	Normal	1321-3R35-C	1321-3RA35-C	1321-3R35-C	1321-3RA35-C
		Heavy	1321-3R45-C	1321-3RA45-C	1321-3R45-C	1321-3RA45-C
30	—	Normal/Heavy	1321-3R35-C	1321-3RA35-C	1321-3R35-C	1321-3RA35-C

**600...690V, 50/60 Hz, Three-phase, 5% Impedance (Continued)**

kW	Hp	Duty	Input Line Reactor		Output Load Reactor	
			IPO0 (Open Style)	IPT1 (NEMA/UL Type 1)	IPO0 (Open Style)	IPT1 (NEMA/UL Type 1)
			Cat. No.	Cat. No.	Cat. No.	Cat. No.
—	40	Normal/Heavy	1321-3R45-C	1321-3RA45-C	1321-3R45-C	1321-3RA45-C
37	—	Normal/Heavy	1321-3R45-C	1321-3RA45-C	1321-3R45-C	1321-3RA45-C
—	50	Normal/Heavy	1321-3R55-C	1321-3RA55-C	1321-3R55-C	1321-3RA55-C
45	—	Normal/Heavy	1321-3R55-C	1321-3RA55-C	1321-3R55-C	1321-3RA55-C
—	60	Normal/Heavy	1321-3R80-C	1321-3RA80-C	1321-3R80-C	1321-3RA80-C
55	—	Normal/Heavy	1321-3R80-C	1321-3RA80-C	1321-3R80-C	1321-3RA80-C
—	75	Normal/Heavy	1321-3R100-C	1321-3RA100-C	1321-3R100-C	1321-3RA100-C
75	—	Normal	1321-3R80-C	1321-3RA80-C	1321-3R80-C	1321-3RA80-C
		Heavy	1321-3R80-C	1321-3RA80-C	1321-3R100-C	1321-3RA100-C
—	100	Normal/Heavy	1321-3R100-C	1321-3RA100-C	1321-3R100-C	1321-3RA100-C
90	—	Normal/Heavy	1321-3R100-C	1321-3RA100-C	1321-3R100-C	1321-3RA100-C
—	125	Normal/Heavy	1321-3R130-C	1321-3RA130-C	1321-3R130-C	1321-3RA130-C
110	—	Normal/Heavy	1321-3R130-C	1321-3RA130-C	1321-3R130-C	1321-3RA130-C
132	—	Normal/Heavy	1321-3R160-C	1321-3RA160-C	1321-3R160-C	1321-3RA160-C
—	150	Normal/Heavy	1321-3R160-C	1321-3RA160-C	1321-3R160-C	1321-3RA160-C
160	—	Normal	1321-3R160-C	1321-3RA160-C	1321-3R160-C	1321-3RA160-C
		Heavy	1321-3RB200-C	1321-3RAB200-C	1321-3RB200-C	A1321-3RAB200-C
—	200	Normal/Heavy	1321-3R200-C	1321-3RA200-C	1321-3R200-C	1321-3RA200-C
200	—	Normal	1321-3RB200-C	1321-3RAB200-C	1321-3RB200-C	1321-3RAB200-C
		Heavy	1321-3RB200-C	1321-3RAB200-C	1321-3RB250-C	1321-3RAB250-C
		Heavy	1321-3R250-C	1321-3RA250-C	1321-3R250-C	1321-3RA250-C
—	250	Normal/Heavy	1321-3RB250-C	1321-3RAB250-C	1321-3RB250-C	1321-3RAB250-C
—	300	Normal/Heavy	1321-3RB320-C	1321-3RAB320-C	1321-3RB320-C	1321-3RAB320-C
250	—	Normal/Heavy	1321-3RB320-C	1321-3RAB320-C	1321-3RB320-C	1321-3RAB320-C
—	350	Light/Normal/Heavy	1321-3RB400-C	1321-3RAB400-C	1321-3RB400-C	1321-3RAB400-C
—	400	Light/Normal/Heavy	1321-3RB400-C	1321-3RAB400-C	1321-3RB400-C	321-3RAB400-C
300	—	Heavy	1321-3RB400-C	1321-3RAB400-C	1321-3RB400-C	1321-3RAB400-C
—	450	Light/Normal/Heavy	1321-3R500-C	1321-3RA500-C	1321-3R500-C	1321-3RA500-C
315	—	Light/Normal	1321-3RB400-C	1321-3RAB400-C	1321-3RB400-C	1321-3RAB400-C
—	500	Light/Normal/Heavy	1321-3R600-C	1321-3RA600-C	1321-3R600-C	1321-3RA600-C
355	—	Light/Normal/Heavy	1321-3R500-C	1321-3RA500-C	1321-3R500-C	1321-3RA500-C
—	550	Light	1321-3R600-C	1321-3RA600-C	1321-3R600-C	1321-3RA600-C
375	—	Heavy	1321-3R500-C	1321-3RA500-C	1321-3R500-C	1321-3RA500-C
400	—	Light/Normal/Heavy	1321-3R500-C	1321-3RA500-C	1321-3R500-C	1321-3RA500-C
450	—	Light/Normal/Heavy	1321-3R600-C	1321-3RA600-C	1321-3R600-C	1321-3RA600-C
500	—	Light/Normal	1321-3R600-C	1321-3RA600-C	1321-3R600-C	1321-3RA600-C
500	—	Heavy	1321-3R600-C	1321-3RA600-C	1321-3R600-C	1321-3RA600-C
530	—	Light	1321-3R600-C	1321-3RA600-C	1321-3R600-C	1321-3RA600-C

**600...690V, 50/60 Hz, Three-phase, 5% Impedance (Continued)**

kW	Hp	Duty	Input Line Reactor		Output Load Reactor	
			IPO0 (Open Style)	IPT1 (NEMA/UL Type 1)	IPO0 (Open Style)	IPT1 (NEMA/UL Type 1)
			Cat. No.	Cat. No.	Cat. No.	Cat. No.
–	600	Normal/Heavy	1321-3R600-C	1321-3RA600-C	1321-3R600-C	1321-3RA600-C
–	700	Light/Normal/Heavy	1321-3R750-C	1321-3RA750-C	1321-3R750-C	1321-3RA750-C
560	–	Normal/Heavy	1321-3R750-C	1321-3RA750-C	1321-3R750-C	1321-3RA750-C
–	750	Heavy	1321-3R750-C	1321-3RA750-C	1321-3R750-C	1321-3RA750-C
630	–	Light/Normal/Heavy	1321-3R750-C	1321-3RA750-C	1321-3R750-C	1321-3RA750-C
–	800	Light/Normal/Heavy	1321-3R850-C	1321-3RA850-C	1321-3R850-C	1321-3RA850-C
710	–	Light/Normal/Heavy	1321-3R850-C	1321-3RA850-C	1321-3R850-C	1321-3RA850-C
–	900	Light/Normal/Heavy	1321-3R850-C	1321-3RA850-C	1321-3R850-C	1321-3RA850-C
750	–	Normal	1321-3R850-C	1321-3RA850-C	1321-3R850-C	1321-3RA850-C
–	950	Light/Normal	1321-3R1000-C	1321-3RA1000-C	1321-3R1000-C	1321-3RA1000-C
800	–	Light/Normal/Heavy	1321-3R1000-C	1321-3RA1000-C	1321-3R1000-C	1321-3RA1000-C
–	1000	Light/Normal	1321-3R1000-C	1321-3RA1000-C	1321-3R1000-C	1321-3RA1000-C
850	–	Light	1321-3R1000-C	1321-3RA1000-C	1321-3R1000-C	1321-3RA1000-C
–	1100	Light	1321-3R600-C <sup>(1)</sup>	1321-3RA600-C <sup>(1)</sup>	1321-3R600-C <sup>(1)</sup>	1321-3RA600-C <sup>(1)</sup>
900	–	Light/Normal	1321-3R600-C <sup>(1)</sup>	1321-3RA600-C <sup>(1)</sup>	1321-3R600-C <sup>(1)</sup>	1321-3RA600-C <sup>(1)</sup>
1000	–	Light	1321-3R600-C <sup>(1)</sup>	1321-3RA600-C <sup>(1)</sup>	1321-3R600-C <sup>(1)</sup>	1321-3RA600-C <sup>(1)</sup>
1100	–	Light/Normal	1321-3R600-C <sup>(2)</sup>	1321-3RA600-C <sup>(2)</sup>	1321-3R600-C <sup>(2)</sup>	1321-3RA600-C <sup>(2)</sup>
–	1200	Light	1321-3R600-C <sup>(2)</sup>	1321-3RA600-C <sup>(2)</sup>	1321-3R600-C <sup>(2)</sup>	1321-3RA600-C <sup>(2)</sup>
1500	–	Light/Normal	1321-3R600-C <sup>(2)</sup>	1321-3RA600-C <sup>(2)</sup>	1321-3R600-C <sup>(2)</sup>	1321-3RA600-C <sup>(2)</sup>
–	1500	Light	1321-3R600-C <sup>(2)</sup>	1321-3RA600-C <sup>(2)</sup>	1321-3R600-C <sup>(2)</sup>	1321-3RA600-C <sup>(2)</sup>

(1) Requires two reactors that are wired in parallel.  
(2) Requires three reactors that are wired in parallel.

## Additional Resources

These documents contain additional information concerning related products from Rockwell Automation. You can view or download publications at [rok.auto/literature](http://rok.auto/literature).

Resource	Description
PowerFlex 755TM IP00 Open Type Kits Technical Data, publication <a href="#">750-TD101</a>	Provides detailed information on: <ul style="list-style-type: none"> <li>• Kit selection</li> <li>• Kit ratings and specifications</li> <li>• Option specifications</li> </ul>
PowerFlex 755TS Products with TotalFORCE Control Installation Instructions, publication <a href="#">750-INT19</a>	Provides the basic steps to install PowerFlex 755TS.
PowerFlex TotalFORCE Firmware Documentation Set: <ul style="list-style-type: none"> <li>• PowerFlex Drives with TotalFORCE Control Programming Manual, publication <a href="#">750-PM101</a></li> <li>• PowerFlex Drives with TotalFORCE Control Parameters Reference Data, publication <a href="#">750-RD101</a></li> <li>• PowerFlex Drives with TotalFORCE Control Conditions Reference Data, publication <a href="#">750-RD102</a></li> </ul>	Provides detailed information on: <ul style="list-style-type: none"> <li>• Startup, control algorithms, and status indicators</li> <li>• Parameters and programming</li> <li>• Faults, alarms, events, and troubleshooting</li> </ul>
PowerFlex Low Voltage Drives Selection Guide, publication <a href="#">PFLEX-SG002</a>	Provides overview and selection information for PowerFlex low voltage drive products.
Drives in Common Bus Configurations with PowerFlex 755TM Bus Supplies Application Techniques, publication <a href="#">DRIVES-AT005</a>	Provides basic information to properly wire and ground the following products in common bus applications: <ul style="list-style-type: none"> <li>• PowerFlex 755TM drive system for common bus solutions</li> <li>• PowerFlex 750-Series AC and DC input drives</li> <li>• Kinetix 5700 servo drives</li> </ul>
PowerFlex 755T Flux Vector Tuning, publication <a href="#">750-AT006</a>	Provides guidance on how to tune Flux Vector position and velocity loops, filters, and other features to achieve the level of performance that is required for a given application. This publication is intended for novice drives users and users with advanced skills.
PowerFlex Drives with TotalFORCE Control Built-in EtherNet/IP Adapter User Manual, publication <a href="#">750COM-UM009</a>	Provides information on how to install, configure, and troubleshoot applications for the PowerFlex drives with the built-in EtherNet/IP adapter.
PowerFlex 755TS Products with TotalFORCE Control Hardware Service Manual, publication <a href="#">750-TG101</a>	Provides detailed information on: <ul style="list-style-type: none"> <li>• Preventive maintenance</li> <li>• Component testing</li> <li>• Hardware replacement procedures</li> </ul>
PowerFlex 750-Series Safe Speed Monitor Option Module Safety Reference Manual, publication <a href="#">750-RM001</a>	These publications provide detailed information on installation, set-up, and operation of the 750-Series safety option modules.
PowerFlex 750-Series Safe Torque Off Option Module User Manual, publication <a href="#">750-UM002</a>	
PowerFlex 750-Series ATEX Option Module User Manual, publication <a href="#">750-UM003</a>	
PowerFlex 755 Integrated Safety - Safe Torque Off Option Module User Manual, publication <a href="#">750-UM004</a>	
PowerFlex 755/755T Integrated Safety Functions Option Module User Manual, publication <a href="#">750-UM005</a>	
PowerFlex 20-HIM-A6 / -C6S HIM (Human Interface Module) User Manual, <a href="#">20HIM-UM001</a>	
Industry Installation Guidelines for Pulse Width Modulated (PWM) AC Drives, publication <a href="#">DRIVES-AT003</a>	Provides basic information on enclosure systems, considerations to help protect against environmental contaminants, and power and grounding considerations for installing Pulse Width Modulated (PWM) AC drives.
Wiring and Grounding Guidelines for Pulse Width Modulated (PWM) AC Drives, publication <a href="#">DRIVES-IN001</a>	Provides basic information to properly wire and ground PWM AC drives.
EtherNet/IP Network Devices User Manual, <a href="#">ENET-UM006</a>	Describes how to configure and use EtherNet/IP devices to communicate on the EtherNet/IP network.
Ethernet Reference Manual, <a href="#">ENET-RM002</a>	Describes basic Ethernet concepts, infrastructure components, and infrastructure features.
CIP Security with Rockwell Automation Products Application Technique, <a href="#">SECURE-AT001</a>	Describes how to plan and implement a Rockwell Automation system that supports the CIP Security protocol.
System Security Design Guidelines Reference Manual, <a href="#">SECURE-RM001</a>	Provides guidance on how to conduct security assessments, implement Rockwell Automation products in a secure system, harden the control system, manage user access, and dispose of equipment.
UL Standards Listing for Industrial Control Products, publication <a href="#">CMPNTS-SR002</a>	Assists original equipment manufacturers (OEMs) with construction of panels, to help ensure that they conform to the requirements of Underwriters Laboratories.
American Standards, Configurations, and Ratings: Introduction to Motor Circuit Design, publication <a href="#">IC-AT001</a>	Provides an overview of American motor circuit design based on methods that are outlined in the NEC.

Resource	Description
Industrial Components Preventive Maintenance, Enclosures, and Contact Ratings Specifications, publication <a href="#">IC-TD002</a>	Provides a quick reference tool for Allen-Bradley industrial automation controls and assemblies.
Safety Guidelines for the Application, Installation, and Maintenance of Solid-state Control, publication <a href="#">SGI-1.1</a>	Designed to harmonize with NEMA Standards Publication No. ICS 1.1-1987 and provides general guidelines for the application, installation, and maintenance of solid-state control in the form of individual devices or packaged assemblies incorporating solid-state components.
Industrial Automation Wiring and Grounding Guidelines, publication <a href="#">1770-4.1</a>	Provides general guidelines for installing a Rockwell Automation industrial system.
PowerFlex AC Drive Performance Specifications per Ecodesign Regulation (EU) 2019/1781 and UK SI 2021 No. 745, publication <a href="#">PFLEX-TD003</a>	Provides specifications per EU and UK Ecodesign, including efficiency class.
Product Certifications website, <a href="#">rok.auto/certifications</a> .	Provides declarations of conformity, certificates, and other certification details.



# Rockwell Automation Support

Use these resources to access support information.

<b>Technical Support Center</b>	Find help with how-to videos, FAQs, chat, user forums, Knowledgebase, and product notification updates.	<a href="http://rok.auto/support">rok.auto/support</a>
<b>Local Technical Support Phone Numbers</b>	Locate the telephone number for your country.	<a href="http://rok.auto/phonesupport">rok.auto/phonesupport</a>
<b>Technical Documentation Center</b>	Quickly access and download technical specifications, installation instructions, and user manuals.	<a href="http://rok.auto/techdocs">rok.auto/techdocs</a>
<b>Literature Library</b>	Find installation instructions, manuals, brochures, and technical data publications.	<a href="http://rok.auto/literature">rok.auto/literature</a>
<b>Product Compatibility and Download Center (PCDC)</b>	Download firmware, associated files (such as AOP, EDS, and DTM), and access product release notes.	<a href="http://rok.auto/pcdc">rok.auto/pcdc</a>

## Documentation Feedback

Your comments help us serve your documentation needs better. If you have any suggestions on how to improve our content, complete the form at [rok.auto/docfeedback](http://rok.auto/docfeedback).





Allen-Bradley, DeviceLogix, expanding human possibility, PowerFlex, Rockwell Automation, SCANport, Studio 5000 Logix Designer, TorqProve, and TotalFORCE are trademarks of Rockwell Automation, Inc.

EtherNet/IP is a trademark of ODVA, Inc.

Trademarks not belonging to Rockwell Automation are property of their respective companies.

Rockwell Automation maintains current product environmental compliance information on its website at [rok.auto/pec](http://rok.auto/pec).

Rockwell Otomasyon Ticaret A.Ş. Kar Plaza İş Merkezi E Blok Kat:6 34752, İçerenköy, İstanbul, Tel: +90 (216) 5698400 EEE Yönetmeliğine Uygundur

Connect with us.    

**rockwellautomation.com** ————— **expanding human possibility®**

AMERICAS: Rockwell Automation, 1201 South Second Street, Milwaukee, WI 53204-2496 USA, Tel: (1) 414.382.2000, Fax: (1) 414.382.4444

EUROPE/MIDDLE EAST/AFRICA: Rockwell Automation NV, Pegasus Park, De Kleetlaan 12a, 1831 Diegem, Belgium, Tel: (32) 2 663 0600, Fax: (32) 2 663 0640

ASIA PACIFIC: Rockwell Automation, Level 14, Core F, Cyberport 3, 100 Cyberport Road, Hong Kong, Tel: (852) 2887 4788, Fax: (852) 2508 1846

UNITED KINGDOM: Rockwell Automation Ltd. Pitfield, Kiln Farm Milton Keynes, MK11 3DR, United Kingdom, Tel: (44)(1908) 838-800, Fax: (44)(1908) 261-917

Publication 750-TD104C-EN-P - June 2023

750-TD104B-EN-P - August 2022

Copyright © 2023 Rockwell Automation, Inc. All rights reserved. Printed in the U.S.A.