

Tool List:

- T25 Torx driver



Net-Verse
D-Type
Cabinet

Front of
Cabinet

D**BCP*
Installed

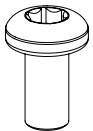

M5x0.8 x 10mm
Pan Head Torx Screw
Qty: 8

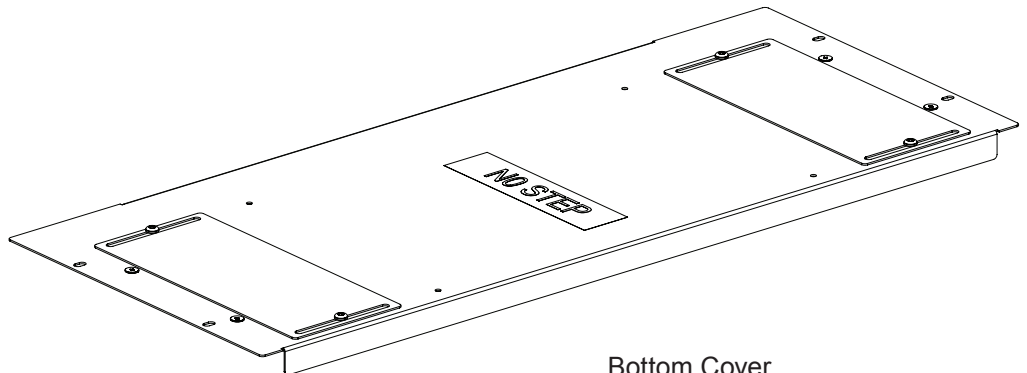

Bottom Cover
Qty: 2

Install Bottom Covers

- Install (1) Bottom Cover from top and slide towards one side of Cabinet.
- Install the second Bottom Cover and slide to the opposite side of Cabinet.
- Secure both Bottom Covers with (4) M5x0.8 x 10mm screws per Bottom Cover.

1

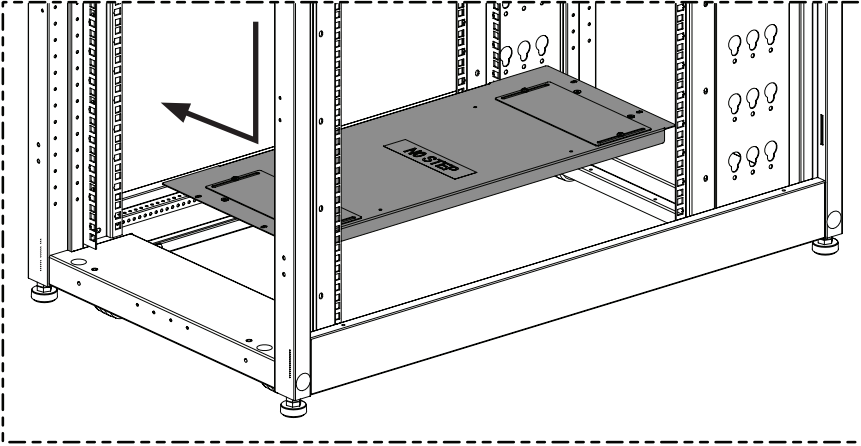

2

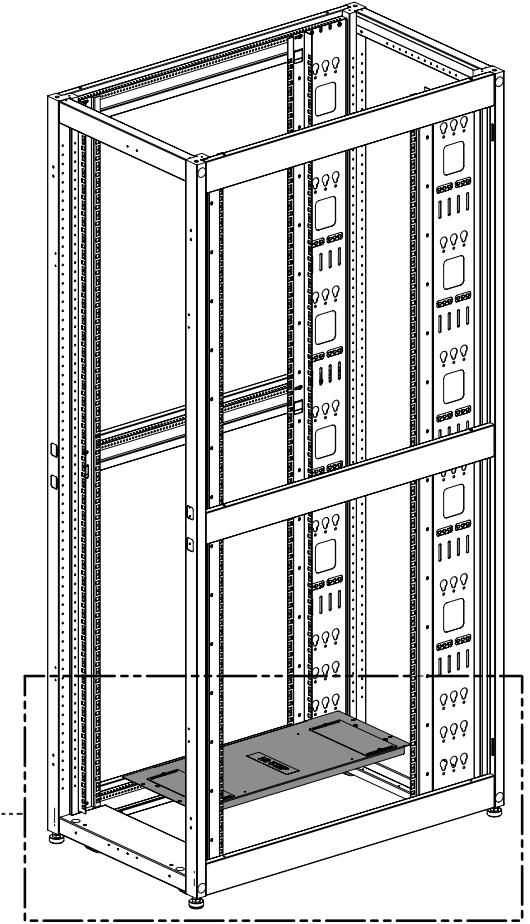
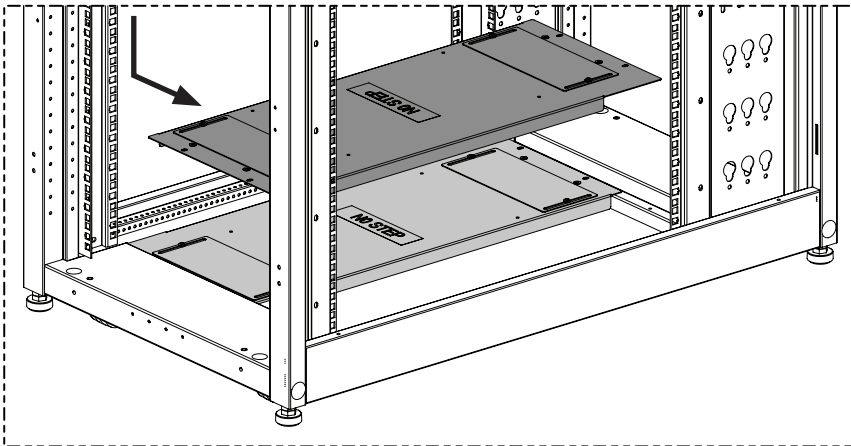

Front of Cabinet

3

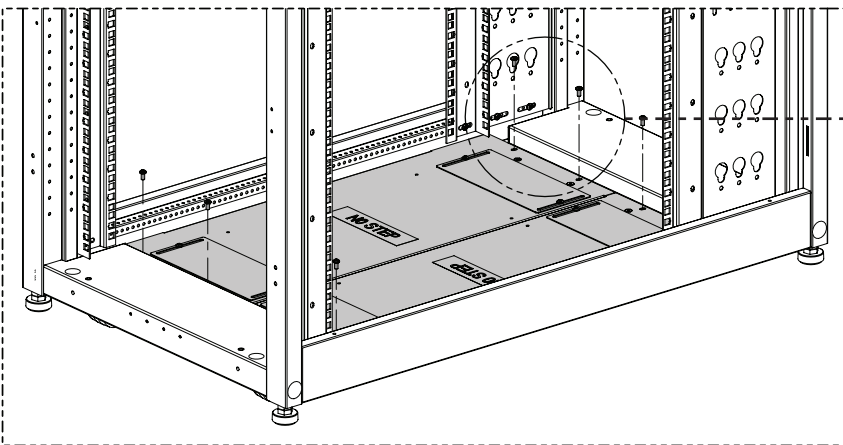

M5x0.8 x 10mm
Pan Head Torx Screw
Qty: 4 per Cover

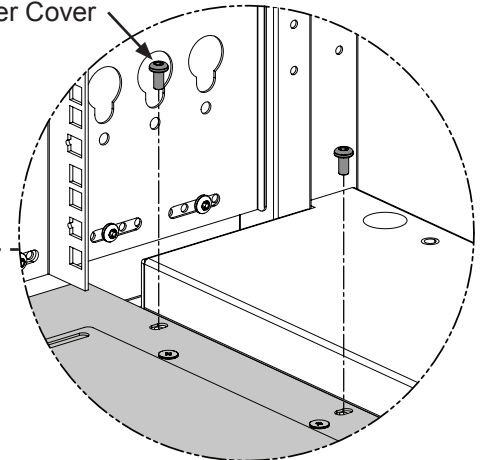

Adjusting Bottom Panel Pass Thru Covers

- Loosen (2) M5x0.8 x 10mm screws and slid Pass Thru Cover to expose up to half of opening.
- Remove Pass Thru Cover and relocate to the other set of holes to expose full opening.
- Route any cables to floor thru the Bottom Panel brushes.

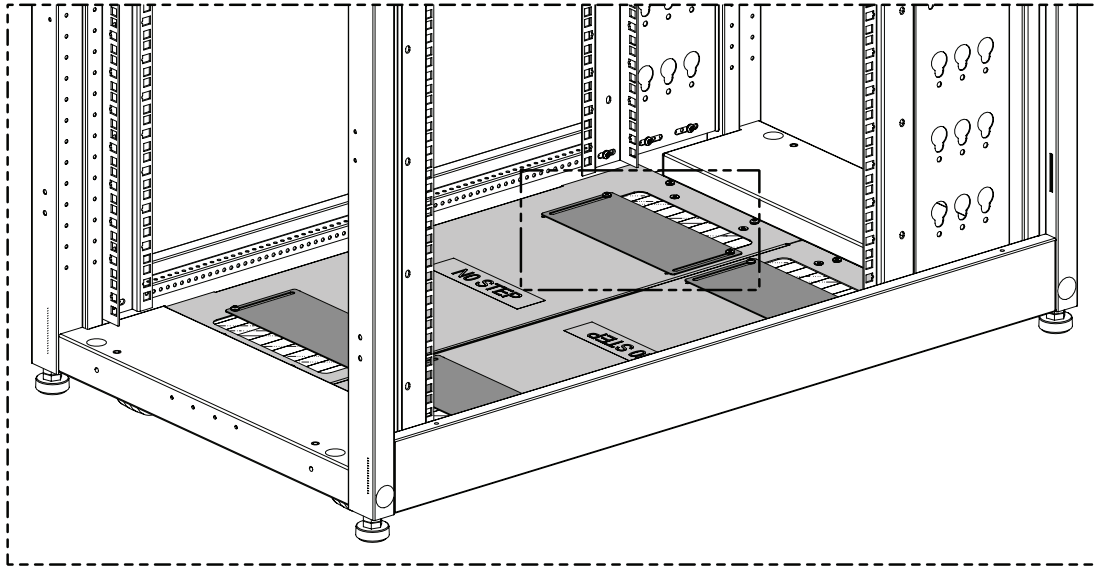

M5x0.8 x 10mm
Pan Head Torx Screw
Qty: 2 per Cover
relocated to second
set of holes

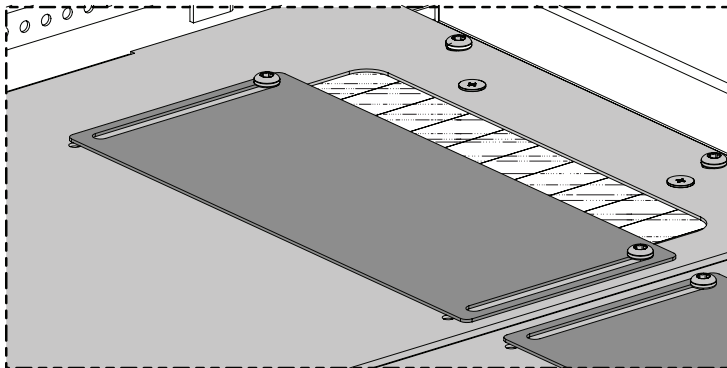

Pass Thru Cover slide open

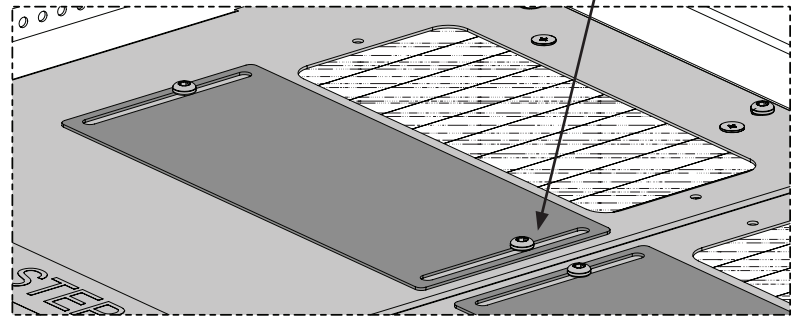

Pass Thru Cover relocated

PDU Cable routed thru the Pass Thru Cover that is fully opened

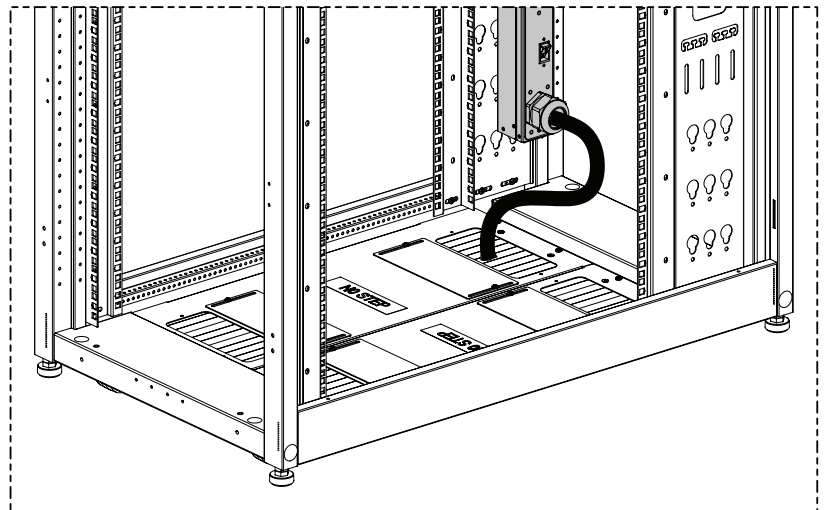

For Instructions in Local Languages
and Technical Support:

www.panduit.com/resources/install_maintain.asp

PANDUIT
www.panduit.com

E-mail:
techsupport@panduit.com

Phone:
866-405-6654