

SIEMENS

RUGGEDCOM RS8000T

Installation Guide

Preface

Introduction

1

Installing the Device

2

Device Management

3

Communication Ports

4

Technical Specifications

5

Certification

6

Copyright © 2018 Siemens Canada Ltd

All rights reserved. Dissemination or reproduction of this document, or evaluation and communication of its contents, is not authorized except where expressly permitted. Violations are liable for damages. All rights reserved, particularly for the purposes of patent application or trademark registration.

This document contains proprietary information, which is protected by copyright. All rights are reserved. No part of this document may be photocopied, reproduced or translated to another language without the prior written consent of Siemens Canada Ltd.

» Disclaimer Of Liability

Siemens has verified the contents of this document against the hardware and/or software described. However, deviations between the product and the documentation may exist.

Siemens shall not be liable for any errors or omissions contained herein or for consequential damages in connection with the furnishing, performance, or use of this material.

The information given in this document is reviewed regularly and any necessary corrections will be included in subsequent editions. We appreciate any suggested improvements. We reserve the right to make technical improvements without notice.

» Registered Trademarks

RUGGEDCOM™ and ROS™ are trademarks of Siemens Canada Ltd.

Other designations in this manual might be trademarks whose use by third parties for their own purposes would infringe the rights of the owner.

» Third Party Copyrights

Siemens recognizes the following third party copyrights:

- Copyright © 2004 GoAhead Software, Inc. All Rights Reserved.

» Security Information

Siemens provides products and solutions with industrial security functions that support the secure operation of plants, machines, equipment and/or networks. They are important components in a holistic industrial security concept. With this in mind, Siemens' products and solutions undergo continuous development. Siemens recommends strongly that you regularly check for product updates.

For the secure operation of Siemens products and solutions, it is necessary to take suitable preventive action (e.g. cell protection concept) and integrate each component into a holistic, state-of-the-art industrial security concept. Third-party products that may be in use should also be considered. For more information about industrial security, visit <https://www.siemens.com/industrialsecurity>.

To stay informed about product updates as they occur, sign up for a product-specific newsletter. For more information, visit <https://support.automation.siemens.com>.

» Warranty

Siemens warrants this product for a period of five (5) years from the date of purchase, conditional upon the return to factory for maintenance during the warranty term. This product contains no user-serviceable parts. Attempted service by unauthorized personnel shall render all warranties null and void. The warranties set forth in this article are exclusive and are in lieu of all other warranties, performance guarantees and conditions whether written or oral, statutory, express or implied (including all warranties and conditions of merchantability and fitness for a particular purpose, and all warranties and conditions arising from course of dealing or usage or trade). Correction of nonconformities in the manner and for the period of time provided above shall constitute the Seller's sole liability and the Customer's exclusive remedy for defective or nonconforming goods or services whether claims of the Customer are based in contract (including fundamental breach), in tort (including negligence and strict liability) or otherwise.

For warranty details, visit <https://www.siemens.com/ruggedcom> or contact a Siemens customer service representative.

» Contacting Siemens

Address

Siemens Canada Ltd
Industry Sector
300 Applewood Crescent
Concord, Ontario
Canada, L4K 5C7

Telephone

Toll-free: 1 888 264 0006
Tel: +1 905 856 5288
Fax: +1 905 856 1995

E-mail

ruggedcom.info.i-ia@siemens.com

Web

<https://www.siemens.com/ruggedcom>

Table of Contents

Preface	vii
Alerts	vii
Related Documents	viii
Accessing Documentation	viii
Training	viii
Customer Support	viii
 Chapter 1	
Introduction	1
1.1 Feature Highlights	1
1.2 Description	2
1.3 Required Tools and Materials	4
1.4 Decommissioning and Disposal	4
1.5 Cabling Recommendations	4
1.5.1 Supported Fiber Optic Cables	5
 Chapter 2	
Installing the Device	7
2.1 General Procedure	7
2.2 Mounting the Device	8
2.2.1 Mounting the Device on a DIN Rail	8
2.2.2 Mounting the Device to a Rack	9
2.2.3 Mounting the Device to a Panel	10
2.3 Connecting the Failsafe Alarm Relay	11
2.4 Connecting Power	12
2.4.1 Connecting AC Power	12
2.4.2 Connecting DC Power	13
 Chapter 3	
Device Management	15
3.1 Connecting to the Device	15
3.2 Configuring the Device	16
3.3 Resetting the Device	16

Chapter 4

Communication Ports	17
4.1 Copper Ethernet Ports	17
4.2 Fiber Optic Ethernet Ports	18

Chapter 5

Technical Specifications	19
5.1 Power Supply Specifications	19
5.2 Failsafe Relay Specifications	20
5.3 Copper Ethernet Port Specifications	20
5.4 Fiber Optic Ethernet Port Specifications	20
5.5 Operating Environment	21
5.6 Mechanical Specifications	21
5.7 Dimension Drawings	21

Chapter 6

Certification	25
6.1 Approvals	25
6.1.1 CSA	25
6.1.2 European Union (EU)	26
6.1.3 FCC	26
6.1.4 ACMA	27
6.1.5 RoHS	27
6.2 EMC and Environmental Type Tests	27

Preface

This guide describes the RUGGEDCOM RUGGEDCOM RS8000T. It describes the major features of the device, installation, commissioning and important technical specifications.

It is intended for use by network technical support personnel who are responsible for the installation, commissioning and maintenance of the device. It is also recommended for use by network and system planners, system programmers, and line technicians.

CONTENTS

- [“Alerts”](#)
- [“Related Documents”](#)
- [“Accessing Documentation”](#)
- [“Training”](#)
- [“Customer Support”](#)

Alerts

The following types of alerts are used when necessary to highlight important information.



DANGER!

DANGER alerts describe imminently hazardous situations that, if not avoided, will result in death or serious injury.



WARNING!

WARNING alerts describe hazardous situations that, if not avoided, may result in serious injury and/or equipment damage.



CAUTION!

CAUTION alerts describe hazardous situations that, if not avoided, may result in equipment damage.



IMPORTANT!

IMPORTANT alerts provide important information that should be known before performing a procedure or step, or using a feature.



NOTE

NOTE alerts provide additional information, such as facts, tips and details.

Related Documents

Other documents that may be of interest include:

- [RUGGEDCOM ROS User Guide](https://support.industry.siemens.com/cs/ww/en/view/109737246) [https://support.industry.siemens.com/cs/ww/en/view/109737246]

Accessing Documentation

The latest user documentation for RUGGEDCOM RS8000T is available online at <https://www.siemens.com/ruggedcom>. To request or inquire about a user document, contact Siemens Customer Support.

Training

Siemens offers a wide range of educational services ranging from in-house training of standard courses on networking, Ethernet switches and routers, to on-site customized courses tailored to the customer's needs, experience and application.

Siemens' Educational Services team thrives on providing our customers with the essential practical skills to make sure users have the right knowledge and expertise to understand the various technologies associated with critical communications network infrastructure technologies.

Siemens' unique mix of IT/Telecommunications expertise combined with domain knowledge in the utility, transportation and industrial markets, allows Siemens to provide training specific to the customer's application.

For more information about training services and course availability, visit <https://www.siemens.com/ruggedcom> or contact a Siemens Sales representative.

Customer Support

Customer support is available 24 hours, 7 days a week for all Siemens customers. For technical support or general information, contact Siemens Customer Support through any of the following methods:



Online

Visit <http://www.siemens.com/automation/support-request> to submit a Support Request (SR) or check on the status of an existing SR.

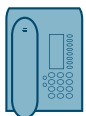

Telephone

Call a local hotline center to submit a Support Request (SR). To locate a local hotline center, visit <http://www.automation.siemens.com/mcms/aspa-db/en/automation-technology/Pages/default.aspx>.



Mobile App

Install the Industry Online Support app by Siemens AG on any Android, Apple iOS or Windows mobile device and be able to:

- Access Siemens' extensive library of support documentation, including FAQs and manuals
- Submit SRs or check on the status of an existing SR

- Contact a local Siemens representative from Sales, Technical Support, Training, etc.
- Ask questions or share knowledge with fellow Siemens customers and the support community

1 Introduction

The RUGGEDCOM RUGGEDCOM RS8000T provides substation hardened, fully managed, Ethernet switches specifically designed to operate reliably in electrically and environmentally harsh environments.

The RUGGEDCOM RS8000T model provides IEEE 1613 Class 2 error-free communications performance under EMI stress. An operating temperature range of -40 to 85 °C (-40 to 185 °F) allows the RUGGEDCOM RS8000T to be placed in almost any location.

The RUGGEDCOM RS8000T provides a wide range of power supply options suitable for multiple industries and for worldwide operability. Options include 24 VDC, 48 VDC, and HI (88-300 VDC or 85-264 VAC)

The RUGGEDCOM RS8000T offers advanced Layer 2 and 3 networking features and network management via the Rugged Operating System (ROS). A unique feature of ROS is the performance of its IEEE 802.1w Rapid Spanning Tree Protocol (RSTP) used for implementing fault tolerant ring and mesh network architectures. The protocol has been optimized to support ring sizes of up to 160 switches and fault recovery times in the order of less than 5 ms per switch.

The RUGGEDCOM RS8000T's superior ruggedized design coupled with the Rugged Operating System (ROS) provides improved system reliability and advanced networking features making it ideally suited for creating Ethernet networks for mission-critical, real-time control applications.

CONTENTS

- [Section 1.1, "Feature Highlights"](#)
- [Section 1.2, "Description"](#)
- [Section 1.3, "Required Tools and Materials"](#)
- [Section 1.4, "Decommissioning and Disposal"](#)
- [Section 1.5, "Cabling Recommendations"](#)

Section 1.1

Feature Highlights

Ethernet Ports

- Six 10/100Base-TX and two 100Base-FX ports
- Multi-mode and single-mode optical transceivers
- Industry standard fiber optical connectors: MTRJ, LC

Rated for Reliability in Harsh Environments

- Immunity to EMI and heavy electrical surges
 - Meets IEEE 1613 Class 2 (electric utility substations)
 - Exceeds IEC 61850-3 (electric utility substations)

- Exceeds IEC 61800-3 (variable speed drive systems)
- Exceeds IEC 61000-6-2 (generic industrial)
- Exceeds NEMA TS-2 (traffic control equipment)
- -40 to 85 °C (-40 to 185 °F) operating temperature (no fans)
- Failsafe Output Relay: For critical failure or error alarming
- Conformal coated printed circuit boards (optional)

Cyber Security Features

- Multi-level user passwords
- SSH/SSL (128-bit encryption)
- Enable/disable ports, MAC based port security
- Port based network access control (802.1x)
- VLAN (802.1Q) to segregate and secure network traffic
- RADIUS centralized password management
- SNMPv3 authentication and 56-bit encryption

Management Tools

- Web-based, Telnet, CLI management interfaces
- SNMP v1/v2/v3 (56-bit encryption)
- Remote Monitoring (RMON)
- Rich set of diagnostics with logging and alarms

Universal Power Supply Options

- Universal high-voltage range: 88-300 VDC or 85-264 VAC
- Popular low voltage ranges: 24 VDC (10-36 VDC), 48 VDC (36-59 VDC)
- Terminal blocks for reliable maintenance free connections
- CSA/UL 60950 safety approved to 85 °C (185 °F)

Section 1.2

Description

The RUGGEDCOM RS8000T features various ports, controls and indicator LEDs on the front and rear panels for configuring and troubleshooting the device.

RS232 Serial Console Port

The serial console port is for interfacing directly with the device and accessing initial management functions. For information about connecting to the device via the serial console port, refer to [Section 3.1, "Connecting to the Device"](#).

Communication Ports

Receive and transmit data. For more information about the various ports available for the RUGGEDCOM RS8000T, refer to [Chapter 4, Communication Ports](#).

Section 1.3

Required Tools and Materials

The following tools and materials are required to install the RUGGEDCOM RS8000T:

Tools/Materials	Purpose
AC or DC power cord (16 AWG)	For connecting power to the device.
CAT-5 Ethernet cables	For connecting the device to the network.
Flathead screwdriver	For mounting the device to a DIN rail.
Phillips screwdriver	For mounting the device to a panel.
4 x #8-32 screws	For mounting the device to a panel.

Section 1.4

Decommissioning and Disposal

Proper decommissioning and disposal of this device is important to prevent malicious users from obtaining proprietary information and to protect the environment.

» Decommissioning

This device may include sensitive, proprietary data. Before taking the device out of service, either permanently or for maintenance by a third-party, make sure it has been fully decommissioned.

For more information, refer to the associated *User Guide*.

» Recycling and Disposal

For environmentally friendly recycling and disposal of this device and related accessories, contact a facility certified to dispose of waste electrical and electronic equipment. Recycling and disposal must be done in accordance with local regulations.

Section 1.5

Cabling Recommendations

All copper Ethernet ports on RUGGEDCOM products include transient suppression circuitry to protect against damage from electrical transients and conform with IEC 61850-3 and IEEE 1613 Class 1 standards. This means

that during a transient electrical event, communications errors or interruptions may occur, but recovery is automatic.

Siemens also does not recommend using copper Ethernet ports to interface with devices in the field across distances that could produce high levels of ground potential rise (i.e. greater than 2500 V), during line-to-ground fault conditions.

CONTENTS

- [Section 1.5.1, "Supported Fiber Optic Cables"](#)

Section 1.5.1

Supported Fiber Optic Cables

The following fiber optic cable types are supported under the stated conditions.

Cable Type	Wavelength (nm)	Modal Bandwidth (MHz·km)	Distance (m)		
			100Base-FX	1000Base-SX	10GBase-SR
OM1 (62.5/125)	850	200	—	275	33
	1300	500	2000	—	—
OM2 (50/125)	850	500	—	550	82
	1300	500	2000	—	—
OM3 (50/125) ^a	850	1500	—	550	300
	1300	500	2000	—	—
OM4 (50/125) ^a	850	3500	—	550	400
	1300	500	2000	—	—

^a Laser optimized.

2 Installing the Device

This chapter describes how to install the device, including mounting the device, connecting power, and connecting the device to the network.



DANGER!

Electrocution hazard – risk of serious personal injury and/or damage to equipment. Before performing any maintenance tasks, make sure all power to the device has been disconnected and wait approximately two minutes for any remaining energy to dissipate.



IMPORTANT!

This product contains no user-serviceable parts. Attempted service by unauthorized personnel shall render all warranties null and void.

Changes or modifications not expressly approved by Siemens Canada Ltd could invalidate specifications, test results, and agency approvals, and void the user's authority to operate the equipment.



IMPORTANT!

*This product should be installed in a **restricted access location** where access can only be gained by authorized personnel who have been informed of the restrictions and any precautions that must be taken. Access must only be possible through the use of a tool, lock and key, or other means of security, and controlled by the authority responsible for the location.*

CONTENTS

- [Section 2.1, "General Procedure"](#)
- [Section 2.2, "Mounting the Device"](#)
- [Section 2.3, "Connecting the Failsafe Alarm Relay"](#)
- [Section 2.4, "Connecting Power"](#)

Section 2.1

General Procedure

The general procedure for installing the device is as follows:

1. Review the relevant certification information for any regulatory requirements. For more information, refer to [Section 6.1, "Approvals"](#).
2. Mount the device.
3. Connect the failsafe alarm relay.
4. Connect power to the device and ground the device to safety Earth.

5. Connect the device to the network.
6. Configure the device.

Section 2.2

Mounting the Device

The RUGGEDCOM RS8000T is designed for maximum mounting and display flexibility. It can be equipped with connectors that allow it to be installed in a 48 cm (19 in) rack, 35 mm (1.4 in) DIN rail, or directly on a panel.



IMPORTANT!

Heat generated by the device is channeled outwards from the enclosure. As such, it is recommended that 2.5 cm (1 in) of space be maintained on all open sides of the device to allow for some convective airflow.

Forced airflow is not required. However, any increase in airflow will result in a reduction of ambient temperature and improve the long-term reliability of all equipment mounted in the rack space.



NOTE

For detailed dimensions of the device with either rack, DIN rail or panel hardware installed, refer to [Section 5.7, "Dimension Drawings"](#).

CONTENTS

- [Section 2.2.1, "Mounting the Device on a DIN Rail"](#)
- [Section 2.2.2, "Mounting the Device to a Rack"](#)
- [Section 2.2.3, "Mounting the Device to a Panel"](#)

Section 2.2.1

Mounting the Device on a DIN Rail

To mount the device to a standard 35 mm (1.4 in) DIN rail, do the following:

1. Align the adapters with the DIN rails and slide the device into place.

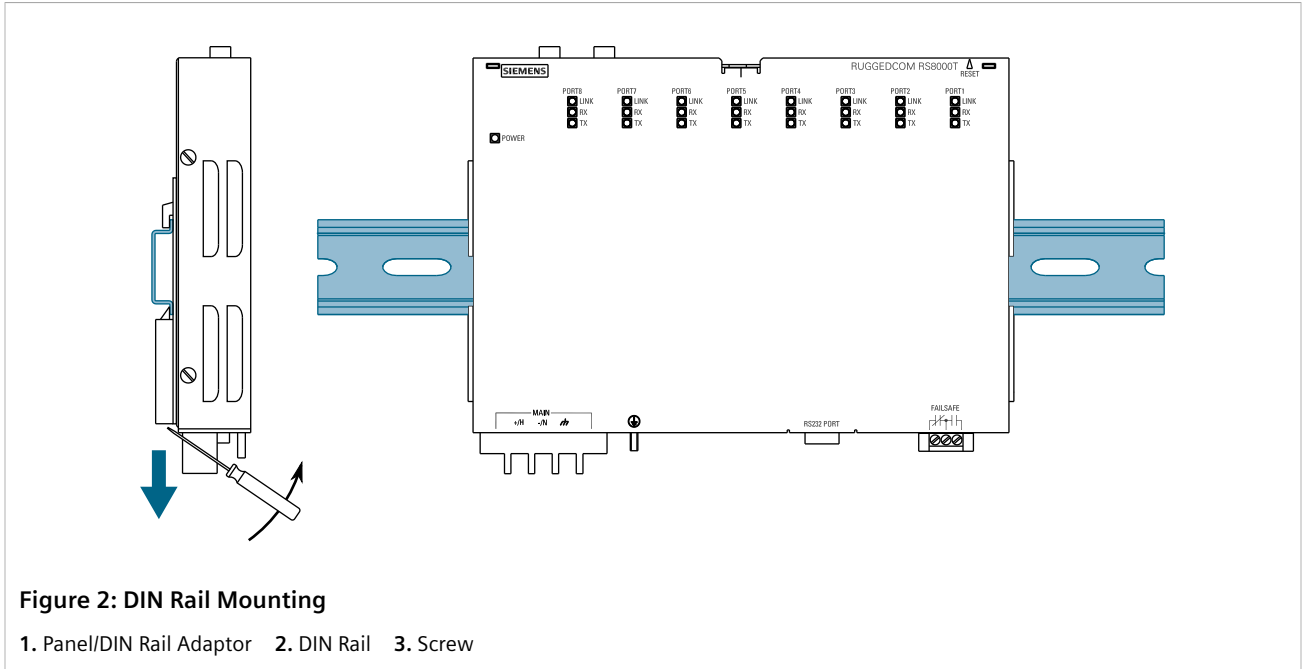

2. Install one of the supplied screws on either side of the device to secure the adapters to the DIN rails.

Section 2.2.2

Mounting the Device to a Rack

To secure the device to a standard 48 cm (19 in) rack, do the following:

1. Remove the four screws from the side of the device.
2. Insert the device into rack mount adapter and use the screws to secure it.



NOTE

The device can be installed with the communication ports facing the front or rear of the rack, depending on the desired orientation.

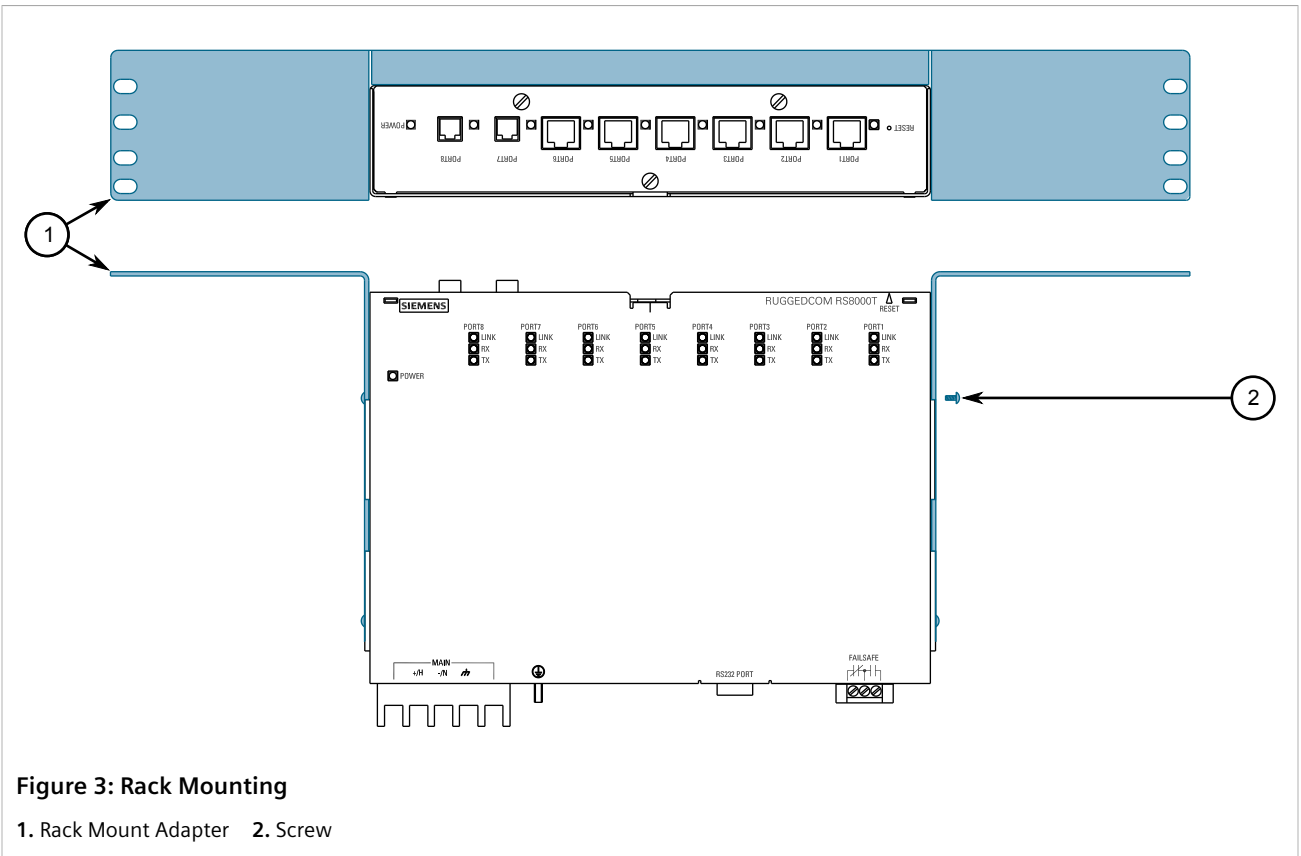

Figure 3: Rack Mounting

1. Rack Mount Adapter 2. Screw

3. Insert the rack mount adapter and device assembly into the rack.



NOTE

Since heat within the device is channelled to the enclosure, it is recommended that 1 rack-unit of space, or 44 mm (1.75 in), be kept empty above the device. This allows a small amount of convectional airflow.

Forced airflow is not required. However, any increase in airflow will result in a reduction of ambient temperature and improve the long-term reliability of all equipment mounted in the rack space.

4. Secure the adapter to the rack using the supplied hardware.

Section 2.2.3

Mounting the Device to a Panel

To mount the device to a panel, do the following:

1. Place the device against the panel and align the adapters with the mounting holes.

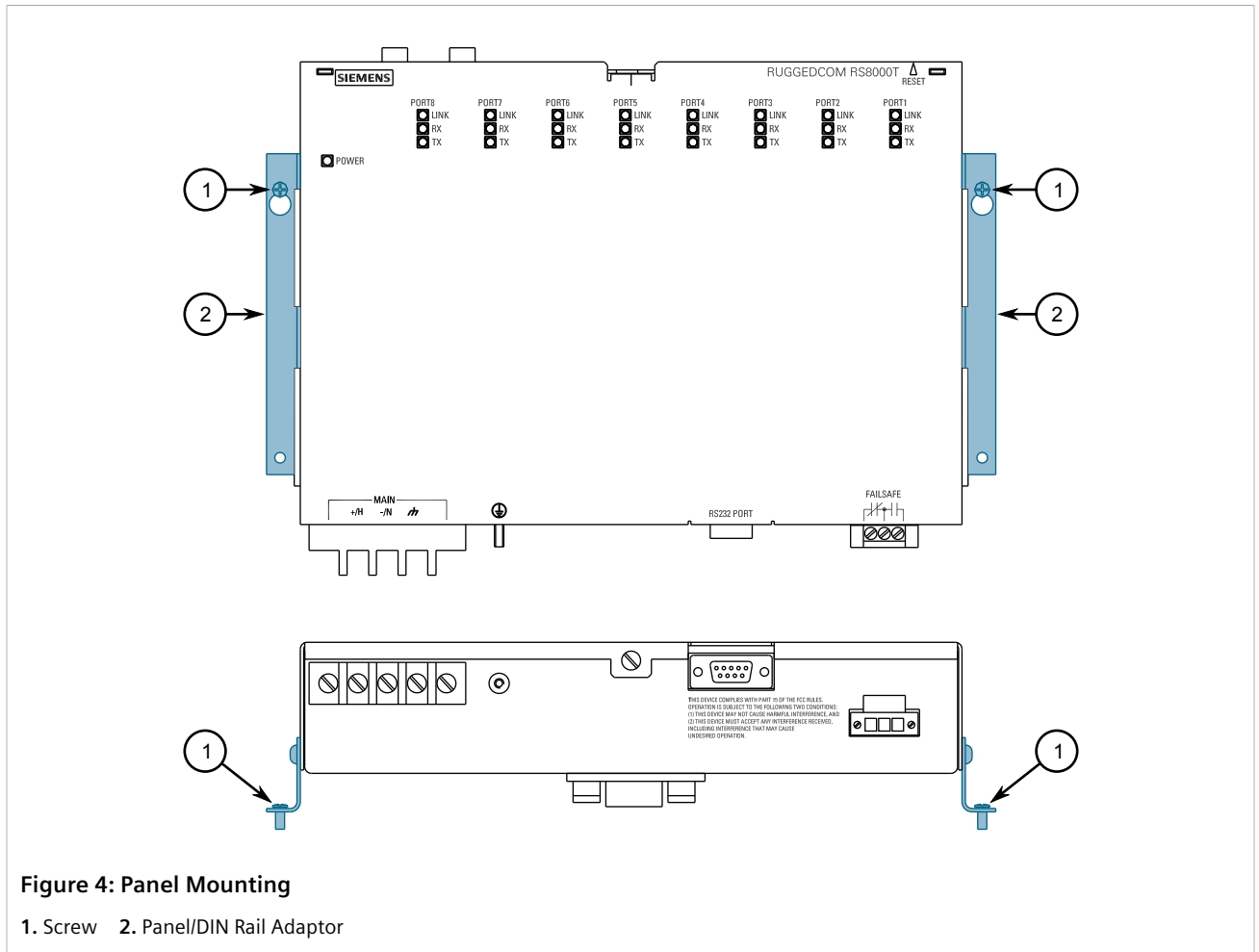

2. Install the supplied screws to secure the adaptors to the panel.

Section 2.3

Connecting the Failsafe Alarm Relay

The failsafe relay can be configured to latch based on alarm conditions. The NO (Normally Open) contact is closed when the unit is powered and there are no active alarms. If the device is not powered or if an active alarm is configured, the relay opens the NO contact and closes the NC (Normally Closed) contact.



NOTE

Control of the failsafe relay output is configurable through ROS. One common application for this relay is to signal an alarm if a power failure occurs. For more information, refer to the ROS User Guide for the RUGGEDCOM RS8000T.

The following shows the proper relay connections.

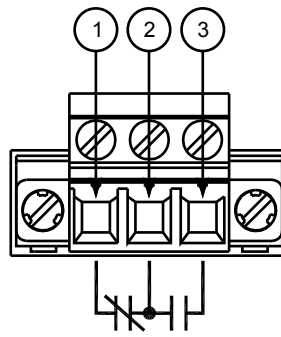

Figure 5: Failsafe Alarm Relay Wiring

1. Normally Closed 2. Common 3. Normally Open

Section 2.4

Connecting Power

The RUGGEDCOM RS8000T supports a single integrated high AC/DC or low DC power supply



IMPORTANT!

- For 88-300 VDC rated equipment, an appropriately rated circuit breaker must be installed.
- For 100-240 VAC rated equipment, an appropriately rated circuit breaker must be installed.
- Use minimum #16 gage wiring when connecting terminal blocks.
- A circuit breaker is not required for 12, 24 or 48 VDC rated equipment.
- Power input terminals have reverse polarity protection for 12, 24 and 48 VDC rated equipment.
- Equipment must be installed according to applicable local wiring codes and standards.

CONTENTS

- [Section 2.4.1, "Connecting AC Power"](#)
- [Section 2.4.2, "Connecting DC Power"](#)

Section 2.4.1

Connecting AC Power

To connect a high AC power supply to the device, do the following:



CAUTION!

Electrical hazard – risk of damage to equipment. Before testing the dielectric strength (HIPOT) in the field, remove the braided ground cable connected to the surge ground terminal and chassis ground. This cable connects transient suppression circuitry to chassis ground and must be removed in order to avoid damage to transient suppression circuitry during testing.

1. Connect the positive wire from the power source to the positive/hot (+/H) terminal on the terminal block.

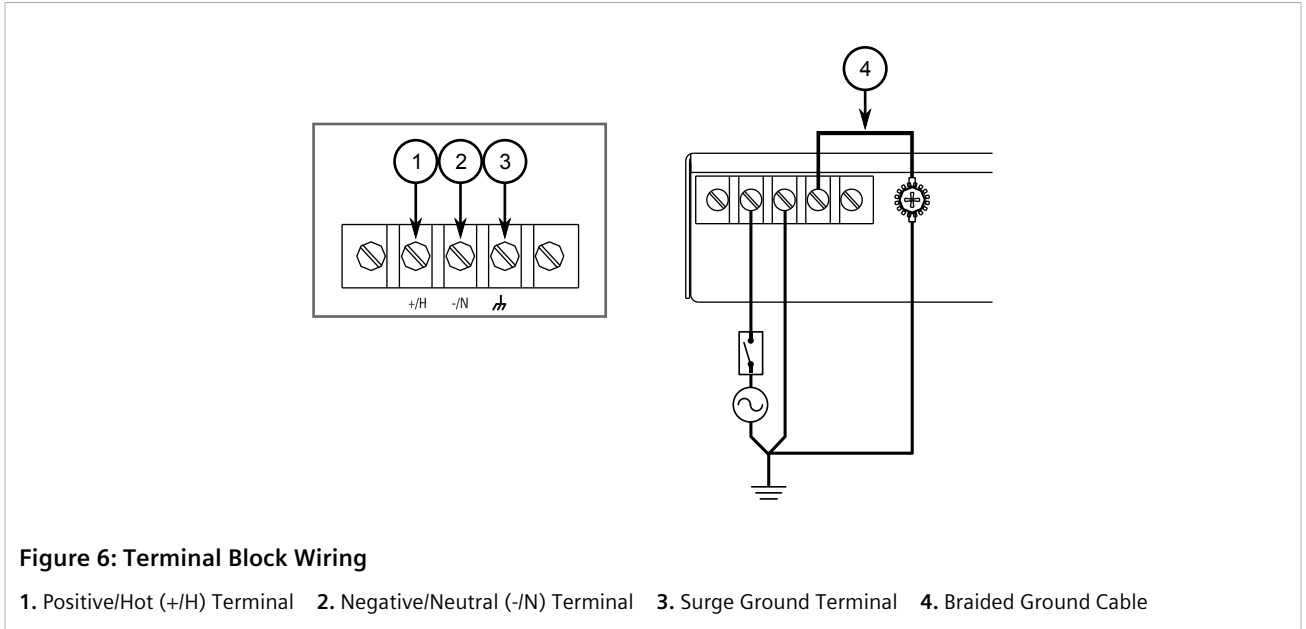

2. Connect the negative wire from the power source to the negative/neutral (-/N) terminal on the terminal block.
3. Using a braided wire or other appropriate grounding wire, connect the surge ground terminal to the chassis ground connection. The surge ground terminal is used as the ground conductor for all surge and transient suppression circuitry internal to the unit.
4. Using a #6 ring lug and #6-32 screw, secure the ground terminal on the power source to the chassis ground terminal on the device. Make sure the lug is tightened to 1.7 N·m (15 lbf·in).

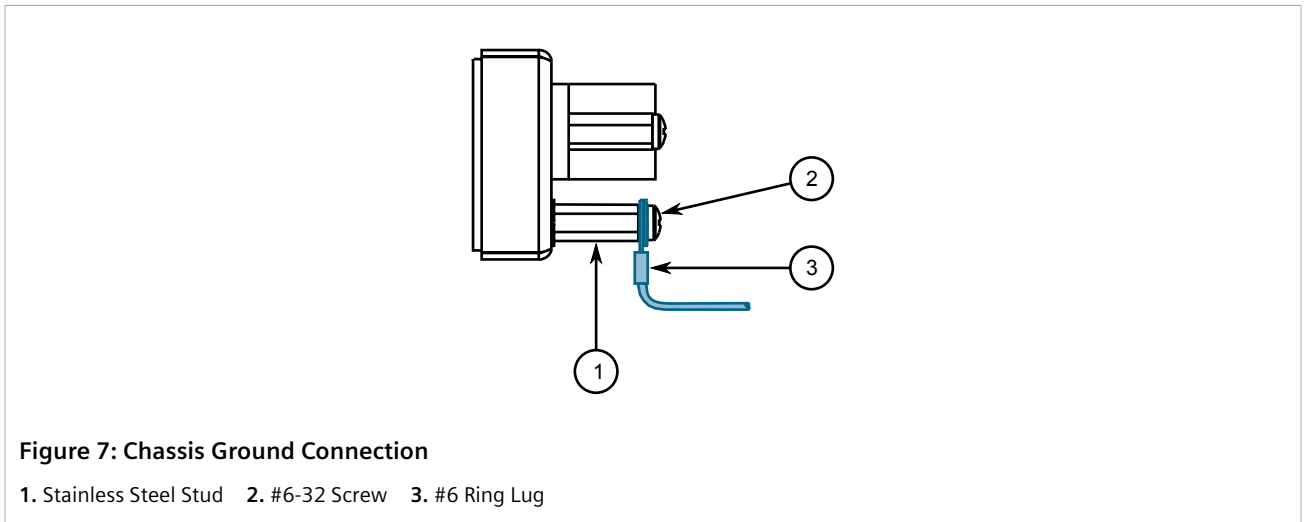

Section 2.4.2

Connecting DC Power

To connect a high or low DC power supply to the device, do the following:



CAUTION!

Electrical hazard – risk of damage to equipment. Before testing the dielectric strength (HIPOT) in the field, remove the braided ground cable connected to the surge ground terminal and chassis ground. This cable connects transient suppression circuitry to chassis ground and must be removed in order to avoid damage to transient suppression circuitry during testing.

1. Connect the positive wire from the power source to the positive/hot (+/L) terminal on the terminal block.

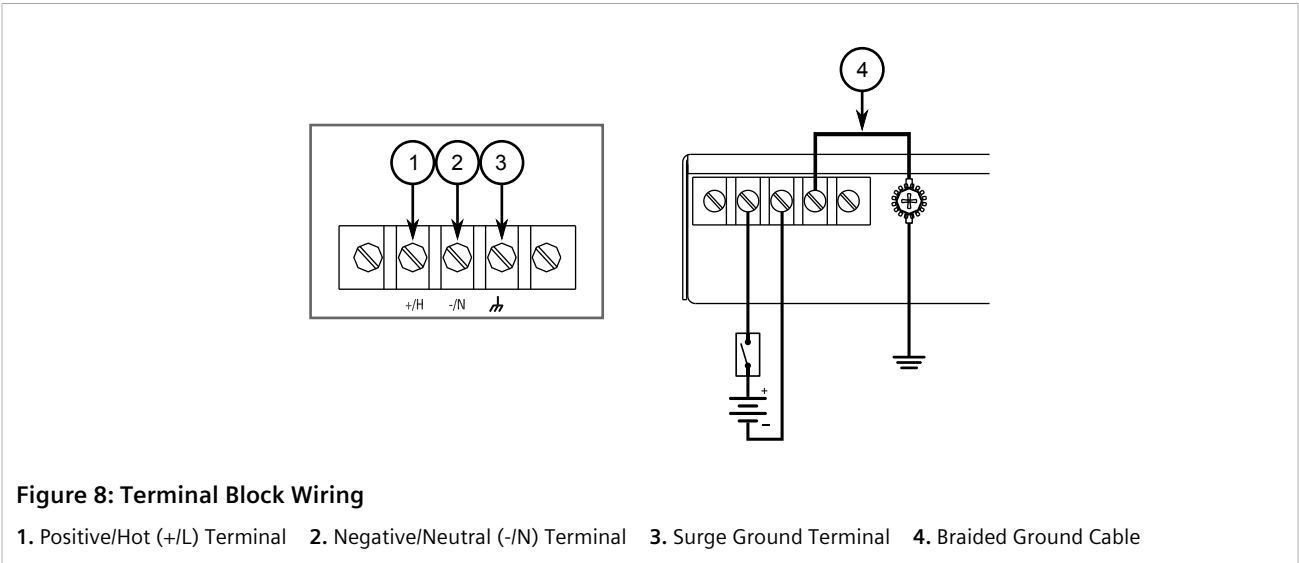

2. Connect the negative wire from the power source to the negative/neutral (-/N) on the terminal block.
3. Using a braided wire or other appropriate grounding wire, connect the surge ground terminal to the chassis ground connection. The surge ground terminal is used as the ground conductor for all surge and transient suppression circuitry internal to the unit.
4. Using a #6 ring lug and #6-32 screw, secure the ground terminal on the power source to the chassis ground terminal on the device. Make sure the lug is tightened to 1.7 N·m (15 lbf·in).

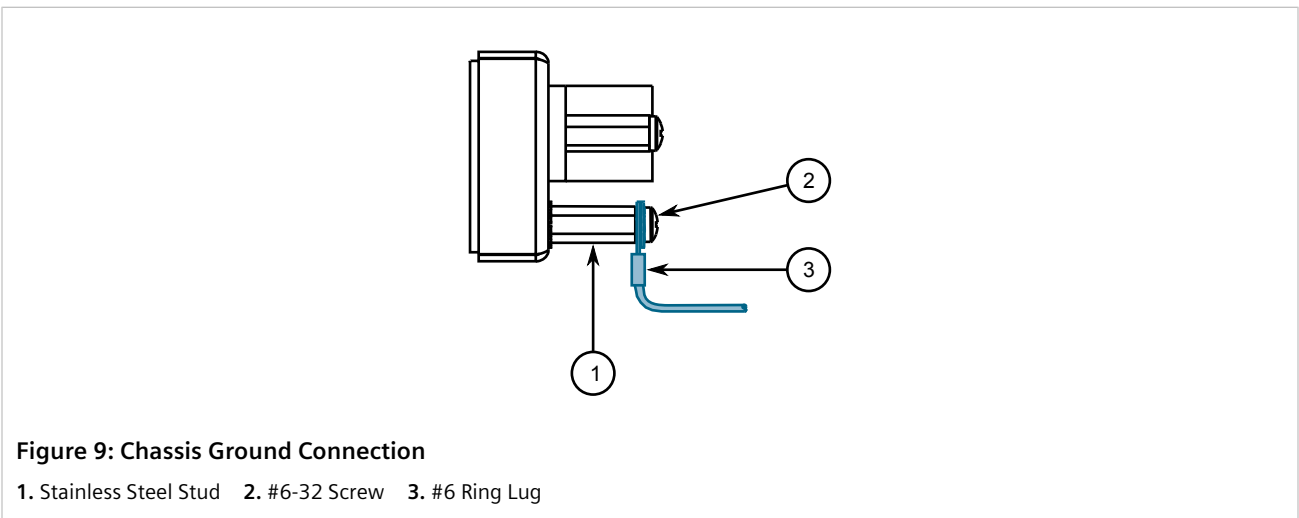

3 Device Management

This section describes how to connect to and manage the device.

CONTENTS

- [Section 3.1, "Connecting to the Device"](#)
- [Section 3.2, "Configuring the Device"](#)
- [Section 3.3, "Resetting the Device"](#)

Section 3.1

Connecting to the Device

The following describes the various methods for accessing the ROS console and Web interfaces on the device. For more detailed instructions, refer to the *ROS User Guide* for the RUGGEDCOM RS8000T.

» Serial Console Port

Connect a PC or terminal directly to the serial console port to access the boot-time control and ROS console interface.



IMPORTANT!

The serial console port is intended to be used only as temporary connections during initial configuration or troubleshooting.

The serial console port implements RS232 DCE (Data Communication Equipment) on a DB9 connector. The following is the pin-out for the port:

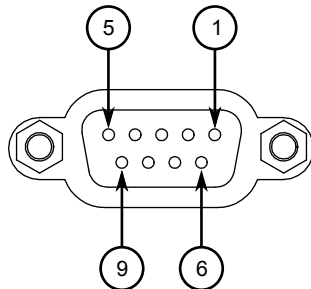

Figure 10: Serial DB9 Console Port

Pin	Name	Description
1	NC	No Connection
2	TX	Transmit Data
3	RX	Receive Data
4	NC	No Connection
5	GND	Signal Ground
6	NC	No Connection
7	NC	No Connection
8	NC	No Connection
9	NC	No Connection

» Communication Ports

Connect any of the available Ethernet ports on the device to a management switch and access the ROS console and Web interfaces via the device's IP address. For more information about available ports, refer to [Chapter 4, Communication Ports](#).

Section 3.2

Configuring the Device

Once the device is installed and connected to the network, it must be configured. All configuration management is done via the RUGGEDCOM ROS interface. For more information about configuring the device, refer to the *RUGGEDCOM ROS User Guide* associated with the installed software release.

Section 3.3

Resetting the Device

The RUGGEDCOM RS8000T can be reset (rebooted) using the **RESET** button. The **RESET** button is recessed and can only be reached using a pin or small screwdriver.

To reset the device, quickly press and release the *RESET* button with a pin.

4 Communication Ports

The RUGGEDCOM RS8000T can be equipped with various types of communication ports to enhance its abilities and performance. To determine which ports are equipped on the device, refer to the factory data file available through ROS. For more information on how to access the factory data file, refer to the *ROS User Guide* for the RUGGEDCOM RS8000T.

Each communication port type has a specific place in the RUGGEDCOM RS8000T chassis.

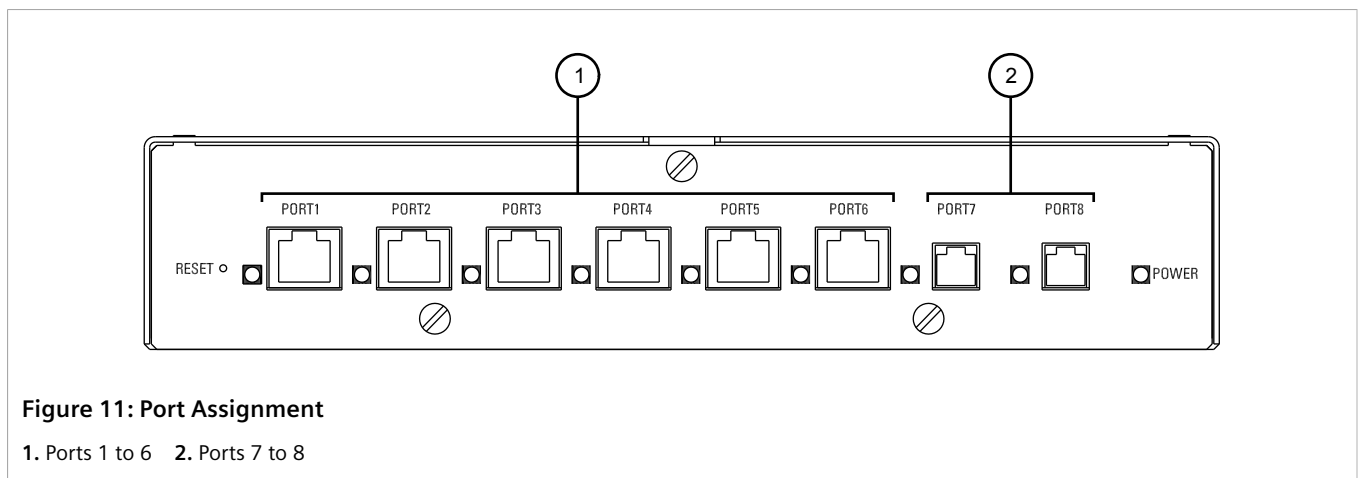

Figure 11: Port Assignment

1. Ports 1 to 6 2. Ports 7 to 8

Port	Type
1 to 6	10/100Base-TX
7 to 8	100Base-FX

CONTENTS

- [Section 4.1, "Copper Ethernet Ports"](#)
- [Section 4.2, "Fiber Optic Ethernet Ports"](#)

Section 4.1

Copper Ethernet Ports

The RUGGEDCOM RS8000T supports several 10/100Base-TX Ethernet ports that allow connection to standard Category 5 (CAT-5) unshielded twisted-pair (UTP) cables with RJ45 male connectors. The RJ45 connectors are directly connected to the chassis ground on the device and can accept CAT-5 shielded twisted-pair (STP) cables.

The following is the pin-out for the RJ45 male connector:

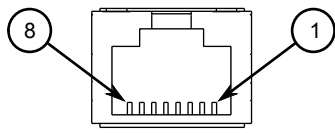

Figure 12: RJ45 Ethernet Port Pin Configuration

Pin	Name	Description
1	RX+	Receive Data+
2	RX-	Receive Data-
3	TX+	Transmit Data+
4		Reserved (Do Not Connect)
5		Reserved (Do Not Connect)
6	TX-	Transmit Data-
7		Reserved (Do Not Connect)
8		Reserved (Do Not Connect)
Case		Shield (Chassis Ground)

For specifications on the available copper Ethernet ports, refer to [Section 5.3, “Copper Ethernet Port Specifications”](#).

Section 4.2

Fiber Optic Ethernet Ports

Fiber optic Ethernet ports are available with either MTRJ (Mechanical Transfer Registered Jack) or LC (Lucent Connector) connectors. Make sure the Transmit (Tx) and Receive (Rx) connections of each port are properly connected and matched to establish a proper link.

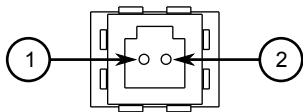

Figure 13: MTRJ Port

1. Tx Connector 2. Rx Connector

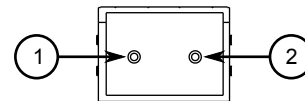

Figure 14: LC Port

1. Tx Connector 2. Rx Connector

For specifications on the available fiber optic Ethernet ports, refer to [Section 5.4, “Fiber Optic Ethernet Port Specifications”](#).

5 Technical Specifications

This chapter provides important technical specifications related to the device.

CONTENTS

- [Section 5.1, “Power Supply Specifications”](#)
- [Section 5.2, “Failsafe Relay Specifications”](#)
- [Section 5.3, “Copper Ethernet Port Specifications”](#)
- [Section 5.4, “Fiber Optic Ethernet Port Specifications”](#)
- [Section 5.5, “Operating Environment”](#)
- [Section 5.6, “Mechanical Specifications”](#)
- [Section 5.7, “Dimension Drawings”](#)

Section 5.1

Power Supply Specifications

Power Supply Type	Input Range		Internal Fuse Rating ^{ab}	Maximum Power Consumption ^c
	Minimum	Maximum		
12-24 VDC	10 VDC	36 VDC	6.3 A(F)	15 W
24 VDC	18 VDC	36 VDC	5 A(F)	
48 VDC	36 VDC	59 VDC	3.15 A(T)	
HI (125/250 VDC) ^d	88 VDC	300 VDC	3.15 A(T)	
HI (110/230 VAC) ^d	85 VAC	265 VAC	3.15 A(T)	

^a (F) denotes fast-acting fuse

^b (T) denotes time-delay fuse.

^c Power consumption varies based on configuration. 10/100Base-TX ports consume roughly 1 W less than fiber optic ports.

^d This is the same power supply for both AC and DC.

Section 5.2

Failsafe Relay Specifications

Voltage	Current
30 VAC	0.3 A
30 VDC	1 A
80 VDC	0.3 A

Section 5.3

Copper Ethernet Port Specifications

The following details the specifications for copper Ethernet ports that can be ordered with the RUGGEDCOM RS8000T.

Speed ^e	10/100Base-TX
Connector	RJ45
Duplex ^e	FDX/HDX
Cable Type ^f	> CAT-5
Wiring Standard ^g	TIA/EIA T568A/B
Maximum Distance ^h	100 m (328 ft)
Isolation ⁱ	1.5 kV

^e Auto-negotiating.

^f Shielded or unshielded.

^g Auto-crossover and auto-polarity.

^h Typical distance. Dependent on the number of connectors and splices.

ⁱ RMS 1 minute.

Section 5.4

Fiber Optic Ethernet Port Specifications

The following details the specifications for fiber optic Ethernet ports that can be ordered with the RUGGEDCOM RS8000T.

Mode ^j	Connector Type	Cable Type (µm)	Tx λ (typ.) (nm)	Tx min. (dBm)	Tx max. (dBm)	Rx Sensitivity (dBm)	Rx Saturation (dBm)	Distance (typ.) (km)	Power Budget (dB)
MM	MTRJ	50/125	1310	-16	-11	-33.5	-11	2	17
		62.5/125	1300	-19	-14	-31	-14		12
SM	LC	9/125	1310	-15	-8	-31	-5	15	16.5

^j MM = Multi-Mode, SM = Single-Mode

Section 5.5

Operating Environment

The RUGGEDCOM RS8000T is rated to operate under the following environmental conditions.

Ambient Operating Temperature ^k	-40 to 85°C (-40 to 185 °F)
Ambient Storage Temperature	-40 to 85°C (-40 to 185 °F)
Ambient Relative Humidity ^l	5% to 95%
Maximum Altitude	2000 m (6562 ft)

^k Ambient Temperature as measured from a 30 cm radius surrounding the center of the enclosure.

^l Non-condensing

Section 5.6

Mechanical Specifications

Weight	2.25 kg (5 lbs)
Ingress Protection	IP30
Enclosure	18 AWG Galvanized Steel

Section 5.7

Dimension Drawings



NOTE

All dimensions are in millimeters, unless otherwise stated.

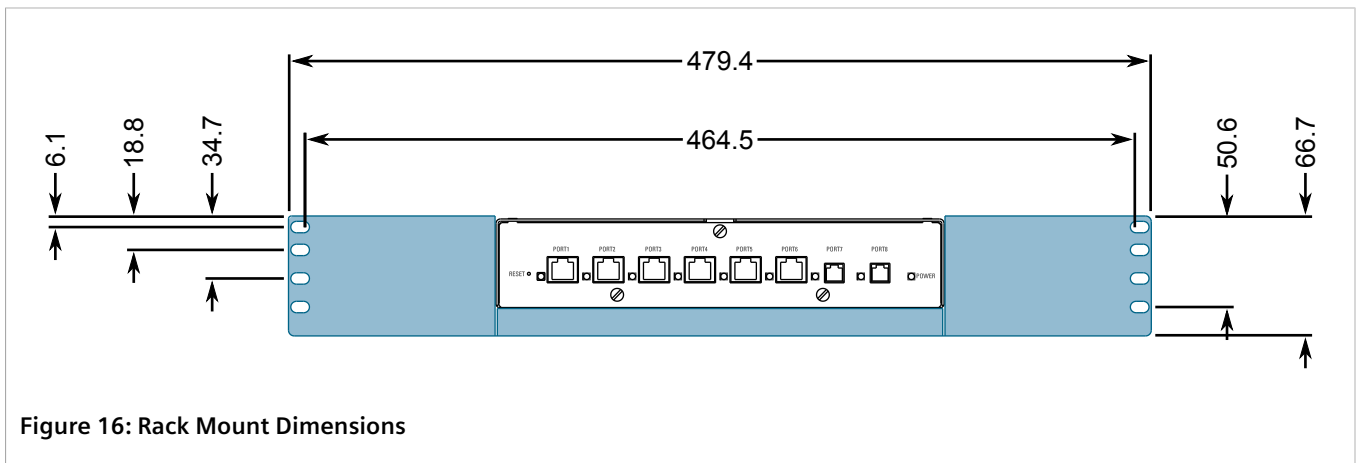
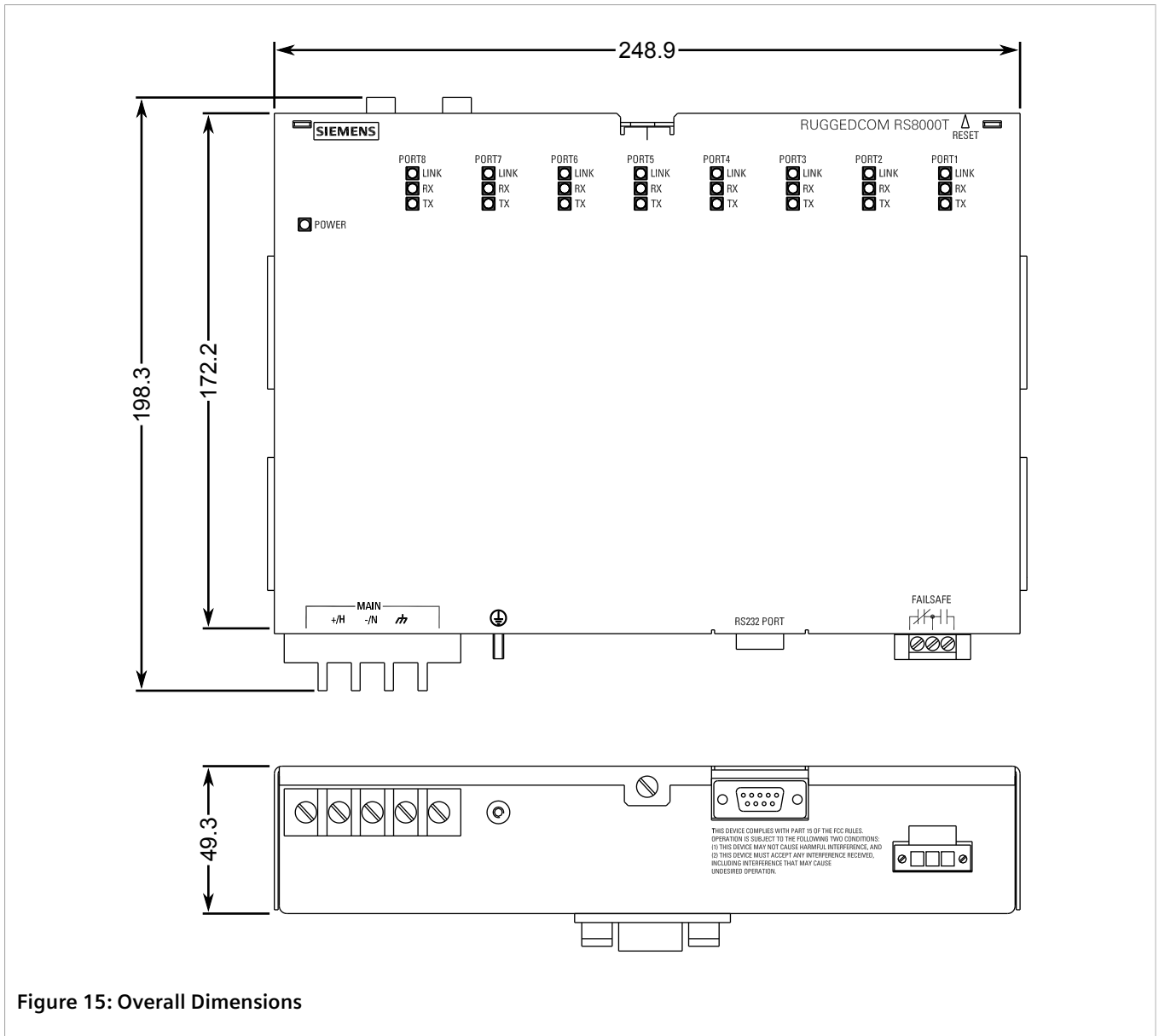

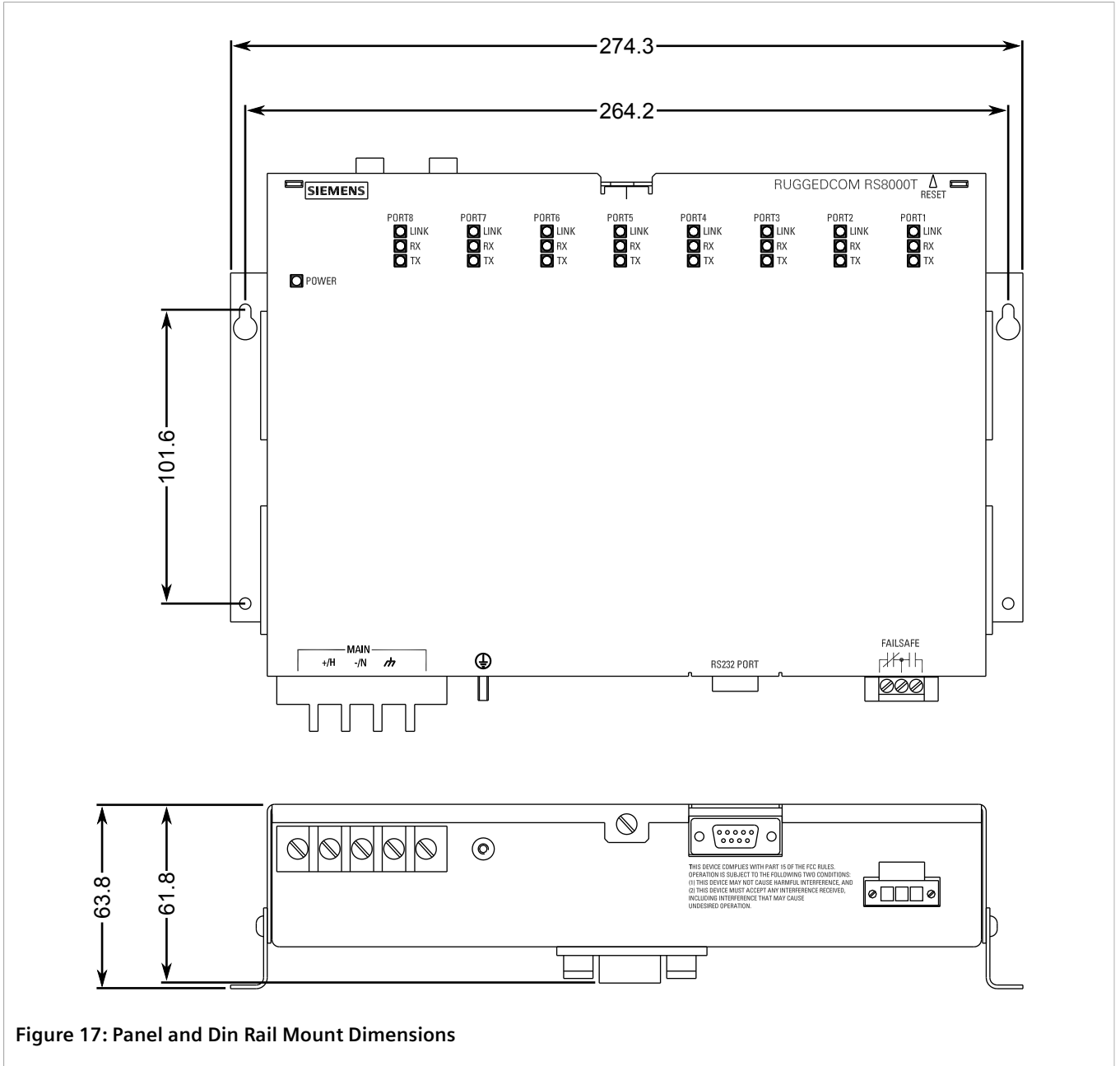

Figure 17: Panel and Din Rail Mount Dimensions

6 Certification

The RUGGEDCOM RS8000T device has been thoroughly tested to guarantee its conformance with recognized standards and has received approval from recognized regulatory agencies.

CONTENTS

- [Section 6.1, "Approvals"](#)
- [Section 6.2, "EMC and Environmental Type Tests"](#)

Section 6.1

Approvals

This section details the standards to which the RUGGEDCOM RS8000T complies.

CONTENTS

- [Section 6.1.1, "CSA"](#)
- [Section 6.1.2, "European Union \(EU\)"](#)
- [Section 6.1.3, "FCC"](#)
- [Section 6.1.4, "ACMA"](#)
- [Section 6.1.5, "RoHS"](#)

Section 6.1.1

CSA

This device is certified by the CSA Group to meet the requirements of the following standards:

- **CSA-C22.2 NO. 60950-1**
Information Technology Equipment – Safety – Part 1: General Requirements (Bi-National standard, with UL 60950-1)
- **UL 60950-1**
Information Technology Equipment – Safety – Part 1: General Requirements)

Section 6.1.2

European Union (EU)

This device is declared by Siemens Canada Ltd to comply with essential requirements and other relevant provisions of the following EU directives:

- **EN 60950-1**
Information Technology Equipment – Safety – Part 1: General Requirements
- **EN 61000-6-2**
Electromagnetic Compatibility (EMC) – Part 6-2: Generic Standards – Immunity for Industrial Environments
- **EN 50581**
Technical Documentation for the Assessment of Electrical and Electronic Products with Respect to the Restriction of Hazardous Substances
- **EN 60825-1**
Safety of Laser Products – Equipment Classification and Requirements
- **EN 55022**
Information Technology Equipment – Radio disturbance characteristics – Limits and methods of measurement

The device is marked with CE and European Explosive Atmosphere symbols and can be used throughout the European community.



A copy of the CE Declaration of Conformity is available from Siemens Canada Ltd. For contact information, refer to [“Contacting Siemens”](#).

Section 6.1.3

FCC

This device has been tested and found to comply with the limits for a Class A digital device, pursuant to Part 15 of the FCC Rules. These limits are designed to provide reasonable protection against harmful interference when the equipment is operated in a commercial environment.

This device generates, uses and can radiate radio frequency energy and, if not installed and used in accordance with the instruction manual, may cause harmful interference to radio communications. Operation of this equipment in a residential area is likely to cause harmful interference in which case users will be required to correct the interference at their own expense.



IMPORTANT!

Changes or modifications not expressly approved by the party responsible for compliance could void the user's authority to operate this device.

Section 6.1.4

ACMA

This device meets the requirements of the following Australian Communications and Media Authority (ACMA) standards under certificate ABN 98 004 347 880:

- Radiocommunications (Compliance Labelling – Devices) Notice 2014 made under Section 182 of the Radiocommunications Act 1992
- Radiocommunications Labelling (Electromagnetic Compatibility) Notice 2008 made under Section 182 of the Radiocommunications Act 1992
- Radiocommunications (Compliance Labelling – Electromagnetic Radiation) Notice 2003 made under Section 182 of the Radiocommunications Act 1992
- Telecommunications Labelling (Customer Equipment and Customer Cabling) Notice 2001 made under Section 407 of the Telecommunication Act 1997

The device is marked with an RCM symbol to indicate compliance when sold in the Australian region.



A copy of the Declaration of Conformity is available via Siemens Industry Online Support at <https://support.industry.siemens.com/cs/ww/en/view/89855782>.

Section 6.1.5

RoHS

This device is declared by Siemens Canada Ltd to meet the requirements of the following RoHS (Restriction of Hazardous Substances) directives for the restricted use of certain hazardous substances in electrical and electronic equipment:

- **China RoHS 2**
Administrative Measure on the Control of Pollution Caused by Electronic Information Products

A copy of the Material Declaration is available online at <https://support.industry.siemens.com/cs/ww/en/view/109738831>.

Section 6.2

EMC and Environmental Type Tests

The RUGGEDCOM RS8000T has passed the following EMC and environmental tests.

» IEC 61850-3 Type Tests

Test	Description	Test Levels	Severity Levels	
IEC 61000-4-2	ESD	Enclosure Contact	±8 kV	4
		Enclosure Air	±15 kV	4

Test	Description		Test Levels	Severity Levels
IEC 61000-4-3	Radiated RFI	Enclosure ports	20 V/m	x
IEC 61000-4-4	Burst (Fast Transient)	Signal ports	±4 kV @ 2.5 kHz	x
		DC Power ports	±4 kV	4
		AC Power ports	±4 kV	4
		Earth ground ports	±4 kV	4
IEC 61000-4-5	Surge	Signal ports	±4 kV line-to-earth, ±2 kV line-to-line	4
		DC Power ports	±2 kV line-to-earth, ±1 kV line-to-line	3
		AC Power ports	±4 kV line-to-earth, ±2 kV line-to-line	4
IEC 61000-4-6	Induced (Conducted) RFI	Signal ports	10 V	3
		DC Power ports	10 V	3
		AC Power ports	10 V	3
		Earth ground ports	10 V	3
IEC 61000-4-8	Magnetic Field	Enclosure ports	40 A/m continuous, 1000 A/m for 1 s	
IEC 61000-4-29	Voltage Dips and Interrupts	DC Power ports	30% for 0.1 s, 60% for 0.1 s, 100% for 0.05 s	
		AC Power ports	30% for 1 period, 60% for 50 periods	
IEC 61000-4-11			100% for 5 periods, 100% for 50 periods	
IEC 61000-4-12	Damped Oscillatory	Signal ports	2.5 kV common, 1 kV differential mode @ 1 MHz	3
		DC Power ports	2.5 kV common, 1 kV differential mode @ 1 MHz	3
		AC Power ports	2.5 kV common, 1 kV differential mode @ 1 MHz	3
IEC 61000-4-16	Mains Frequency Voltage	Signal ports	30 V Continuous, 300 V for 1 s	4
		DC Power ports	30 V Continuous, 300 V for 1 s	4
IEC 61000-4-17	Ripple on DC Power Supply	DC Power ports	10%	3
IEC 60255-5	Dielectric Strength	Signal ports	2 kVAC (Fail-Safe Relay output)	
		DC Power ports	1.5 kVDC	
		AC Power ports	2 kVDC	
	HV Impulse	Signal ports	5 kV (Fail-Safe Relay Output)	
		DC Power ports	5 kV	
		AC Power ports	5 kV	

» IEEE 1613 (C37.90.x) EMC Immunity Type Tests



NOTE

The RUGGEDCOM RS8000T meets Class 2 requirements for an all-fiber configuration and Class 1 requirements for copper ports.

IEEE Test	IEEE 1613 Clause	Description		Test Levels
C37.90.3	9	ESD	Enclosure Contact	±8 kV
			Enclosure Air	±15 kV
C37.90.2	8	Radiated RFI	Enclosure ports	35 V/m
C37.90.1	7	Fast Transient	Signal ports	±4 kV @ 2.5 kHz
			DC Power ports	±4 kV
			AC Power ports	±4 kV
			Earth ground ports	±4 kV
		Oscillatory	Signal ports	2.5 kV common mode @ 1MHz
			DC Power ports	2.5 kV common and differential mode @ 1MHz
AC Power ports	2.5 kV common and differential mode @ 1MHz			
C37.90	6	HV Impulse	Signal ports	5 kV (Failsafe Relay)
			DC Power ports	5 kV
			AC Power ports	5 kV
		Dielectric Strength	Signal ports	2 kVAC (Failsafe Relay)
			DC Power ports	1.5 kVDC
			AC Power ports	2 kVAC

» Environmental Type Tests

Test	Description		Test Levels	Severity Levels
IEC 60068-2-1	Cold Temperature	Test Ad	-40 °C (-40 °F), 16 Hours	
IEC 60068-2-2	Dry Heat	Test Bd	85 °C (185 °F), 16 Hours	
IEC 60068-2-30	Humidity (Damp Heat, Cyclic)	Test Db	95% (non-condensing), 55 °C (131 °F), 6 cycles	
IEC 60255-21-1	Vibration		2 g @ 10-150 Hz	Class 2
IEC 60255-21-2	Shock		30 g @ 11 ms	Class 2

