

free cables 1500 mm
for cable type see
configuration manual

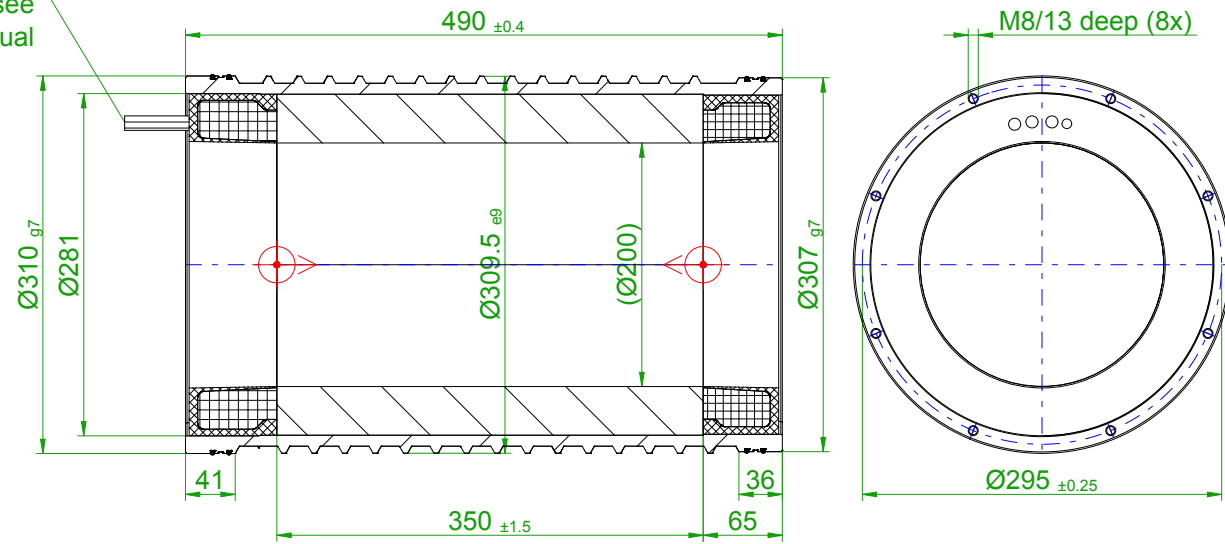

coolant
inlet/outlet



interface instructions
stator interface dimensions

- 1) edges fillet $R_{max} 16$
- 2) coolant connection $\varnothing 12$ max.
- 3) drain hole $\varnothing 5$ max.

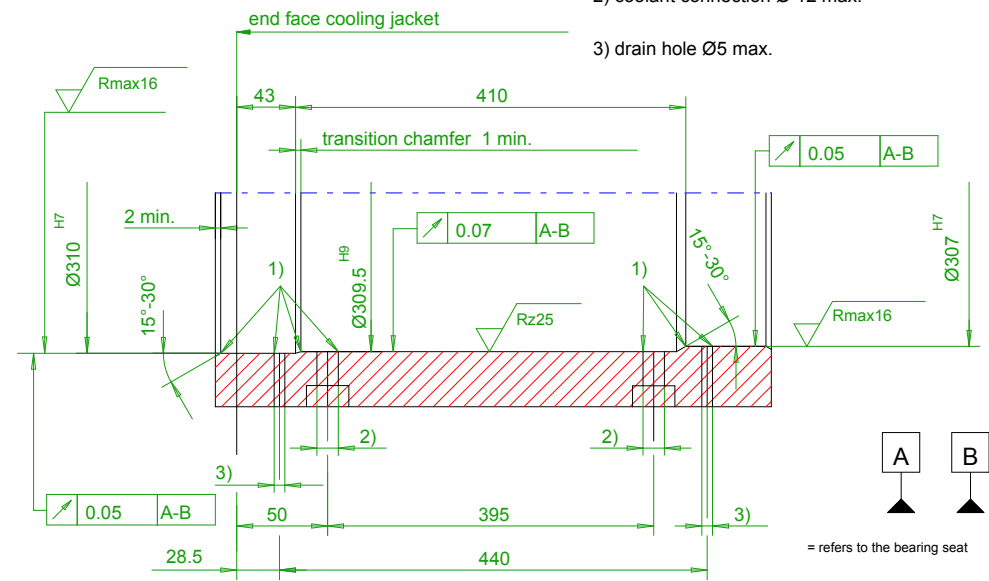

temperature-sensors can be damaged

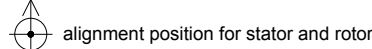

scope of delivery with o-ring-seals

enclosure IP00

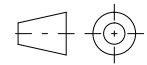

SIEMENS

Einheit / unit: mm	Einbau-Synchronmotor, Stator Built-in synchronous motor, stator:	1FE1147-8WN11-1B_0
nicht tolerierte Maße / not toleranced dimensions:	Optionen / options:	
Maßstab / scale: ohne / without	Gewicht / mass:	116 kg
CAD CREATOR 2.2 (WWW-Version V02.20.00.00)	Bemerkung / notice:	
	Druckdatum / print date:	18.02.2020