







Connection system MOTION-CONNECT



13/2	Overview
13/3	Introduction
13/3	General information
13/5	Power cables for SINAMICS S110 and S120
13/7	Power cables for 1FK7 motors with SPEED-CONNECT connector
13/8	Extensions for power cables with SPEED-CONNECT connector
13/9	Power cables for 1PH8 motors with terminal box
13/10	Signal cables for SINAMICS S110 and S120
13/13	DRIVE-CLiQ signal cables without 24 V DC cores
13/14	MOTION-CONNECT DRIVE-CLiQ signal cables with 24 V DC cores
13/15	Signal cables for motors with SPEED-CONNECT/full-thread connector Basic cables/extensions
13/16	Connection overviews
13/18	Length code

Connection system MOTION-CONNECT

Overview

Cable	For motor	MOTION-CONNECT 500	MOTION-CONNECT 800PLUS	Page
Dynamic requirements		Medium	High	
Environmental requirements		Medium	High	
UL/CSA		✓	✓	
Halogen-free		-	✓	
RoHS		✓	✓	
Power cables with SPEED-CONNECT connector				
	1FK7	✓	✓	13/7
Extensions for power cables with SPEED-CONNECT connector				
	1FK7	✓	✓	13/8
Power cables for motors with terminal box				
	1PH8	✓	✓	13/9
MOTION-CONNECT DRIVE-CLiQ signal cables				
	1FK7	✓	✓	13/14
	1PH8	✓	✓	13/14
Signal cables with SPEED-CONNECT/full-thread connector				
	1FK7	✓	✓	13/15
	1PH8	✓	✓	13/15
Extensions for signal cables with SPEED-CONNECT/full-thread connector				
	1FK7	✓	✓	13/15

✓ = Possible
- = Not possible

Overview

MOTION-CONNECT cables are suitable for use with many different types of machine tools and production machines.

MOTION-CONNECT cables are available as ready-to-connect power and signal cables as well as cables sold by the meter in the following versions:

- **MOTION-CONNECT 500**
 - Cost-effective solution for mainly fixed installation
 - Use for low mechanical loads
 - Tested for traversing paths up to 5 m (16.41 ft)
- **MOTION-CONNECT 800PLUS**
 - Fulfills the requirements for use in cable carriers
 - Use for high mechanical loads
 - Oil resistance
 - Tested for traversing paths up to 50 m (164 ft)

Benefits

The pre-assembled MOTION-CONNECT cables ensure high quality and system-tested, problem-free operation. MOTION-CONNECT cables have been tested in a cable carrier.

SPEED-CONNECT

The new pre-assembled cables with SPEED-CONNECT connectors support a fast, stable and reliable connection. With a short rotation as far as the stop, the lock nut of the connector secures the connection.

The cables with SPEED-CONNECT connectors supplement the previously offered MOTION-CONNECT cables with full-thread connectors.

Application

MOTION-CONNECT cables are designed for use in a machine. They are not intended for use in building management systems or outdoors. The MOTION-CONNECT cables have been tested in a cable carrier with horizontal traversing path and have also been designed for this type of application.

The pre-assembled cables can be ordered in length units of 10 cm (3.94 in) and can be extended, if necessary.

When cable lengths (basic cables and extensions) are determined for the systems and applications described in this catalog, the technically permissible maximum cable lengths (e.g. 25 m (82 ft)) specified in the catalog must be observed. Malfunctions can occur if longer cables are used.

Siemens AG assumes no liability for correct transmission of signals or power in this case.

Compatibility between connectors with SPEED-CONNECT and full-thread:

Connector on motor with external thread	Connector with lock nut on the cable	Compatibility
SPEED-CONNECT	SPEED-CONNECT	✓
SPEED-CONNECT	Full-thread	✓
Full-thread	Full-thread	✓
Full-thread	SPEED-CONNECT	–

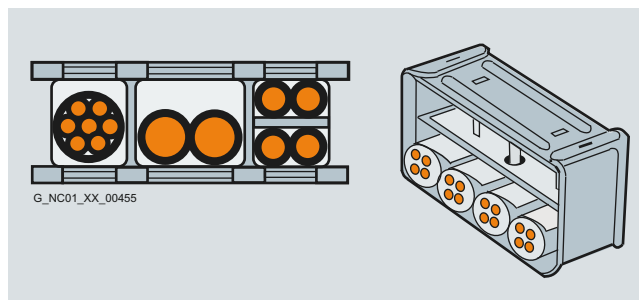
Function

To maximize the service life of the cable carrier and cables, cables in the carrier made from different materials must be separated in the cable carrier using spacers. The spacers must be filled evenly to ensure that the position of the cables does not change during operation. The cables should be distributed as symmetrically as possible according to their weights and dimensions. Cables with very different outer diameters should be separated by spacers.

The strain relief for the cables must be realized through a large surface area at the surface of the cable jacket without crushing the cable structure.

The cable fixings must be attached at both ends at an appropriate distance away from the end points of the moving parts in a dead zone.

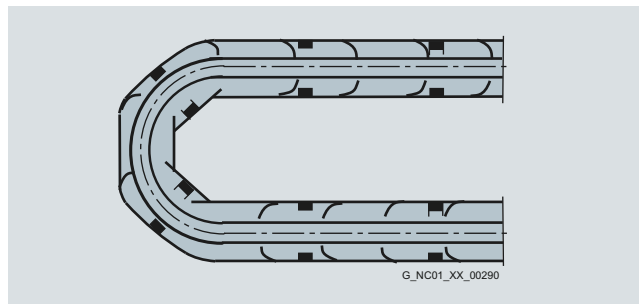

The cables must not be fixed in the cable carrier. They must be freely movable. The cables must be able to be moved without applying force in particular in the bending radii of the carrier. The specified minimum bending radii must be adhered to.

Cables must be installed in accordance with the instructions supplied by the cable carrier manufacturer.

When inserting pre-assembled cables into the cable carrier, do **not** pull at the connector, as this may damage the strain relief or cable clamping.

In case of vibration load and with horizontal or vertical cable entries, we recommend that the cable is additionally fixed if between the cable strain relief on the cable carrier and the terminal at the motor part of the cable is hanging loose or is not routed. To prevent machine vibrations being transmitted to the connectors, the cable should be fixed at the moving part where the motor is mounted.

Connection system MOTION-CONNECT

Introduction

General information

Characteristic curves

Possible use for the cables lies in the area below the characteristic curve. The characteristic curves represent the tested usage points.

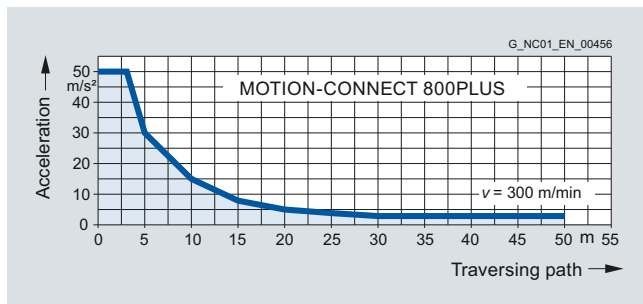

Acceleration for signal and power cables MOTION-CONNECT 800PLUS up to 16 mm²

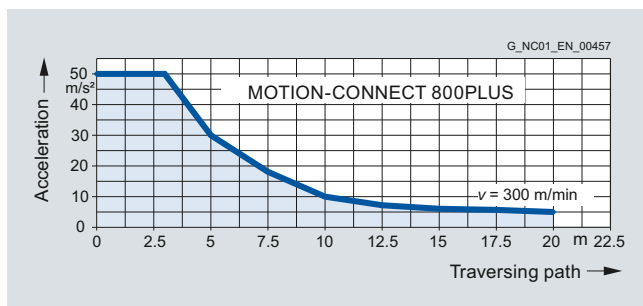

Acceleration for power cables MOTION-CONNECT 800PLUS with 25 mm², 35 mm² and 50 mm²

More information

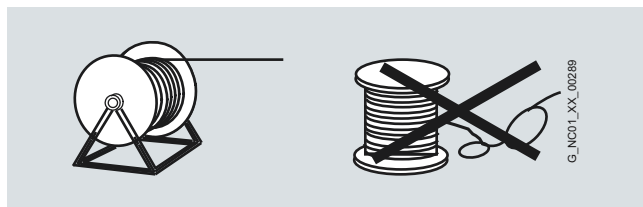

The cables must be removed from the drum without twisting, i.e. the cables must be unwound and must never be lifted over the drum flange in loops.

Representation in connection overviews

Symbol	Explanation
	Connector with pin contacts
	Connector with socket contacts
	Exposed core ends
	Cable is not included in the scope of delivery. It must be provided by the customer.

More information (continued)

Current carrying capacity for power and signal cables

The current carrying capacity of PVC/PUR-insulated copper cables is specified in the table for installation types B1, B2, C and E under continuous operating conditions with reference to an ambient air temperature of 40 °C (104 °F). For other ambient temperatures, the values must be corrected by the derating factors from the table.

Cross-section	Current carrying capacity			
	rms AC 50/60 Hz or DC in amps for installation type			
	B1	B2	C	E
	Single-core cables in protection tubes or installation ducts	Multi-core cables in protection tubes or installation ducts	Multi-core cables, vertically or horizontally on walls / open, without protection tubes and installation ducts / with contact	Multi-core cables, horizontally or vertically on perforated cable racks / open, without protection tubes and installation ducts / with contact
mm ²				
Electronics (one control circuit pair)				
0.20	–	4.3	4.4	4.4
0.30	–	7.5	7.5	7.8
0.75	–	9	9.5	10
Power (one symmetrically loaded AC cable)				
1.50	13.5	13.1	15.2	16.1
2.50	18.3	17.4	21	22
4	24	23	28	30
6	31	30	36	37
10	44	40	50	52
16	59	54	66	70
25	77	70	84	88
35	96	86	104	110
50	117	103	125	133
70	149	130	160	171

Derating factors for power and signal cables

Ambient air temperature °C (°F)	Derating factor according to EN 60204-1, Table D.1
30 (86)	1.15
35 (95)	1.08
40 (104)	1.00
45 (113)	0.91
50 (122)	0.82
55 (131)	0.71
60 (140)	0.58

Connection system MOTION-CONNECT

Power cables for SINAMICS S110 and S120

Overview



Power cable for connecting a 1PH8 motor with terminal box to a SINAMICS S120 Power Module

MOTION-CONNECT power cables are used to connect synchronous and asynchronous (induction) motors with the Power Modules.

The pre-assembled MOTION-CONNECT power cables are of high quality and offer safety with problem-free functioning.

Depending on the design, the MOTION-CONNECT power cables are either pre-assembled at one end or at both ends.

If pre-assembled cables are installed in a cable carrier in such a way that the connector would inhibit assembly, pre-assembled cables without assembled connectors can also be supplied. In this case, the contacts of the cables are crimped and the connector enclosure is supplied separately. After installing the cables, the customer assembles the connector enclosure.

On request, all 6FX.002-5....-.... power cables are available with crimped contacts and with the connector enclosure **for the module end** supplied separately.

In this case, the 6th position of the Order No. must be changed from **0** to **1**: 6FX.012-5....-....

Note:

Once the contacts have latched into the insulator, they can no longer be removed.



Power cable with connector supplied for connecting a 1FK7 motor to a SINAMICS S120 Power Module

Type of delivery of pre-assembled power cables

Pre-assembled power cables can be ordered in length units of 10 cm (3.94 in) up to 299.8 m (984 ft).

Cables up to 30 kg (66.2 lb) or 100 m (328 ft) are supplied as coils; above this, they are supplied on drums. This applies to both pre-assembled power cables and to those sold by the meter.

Type of delivery of power cables sold by the meter

Fixed lengths

Cross-section	MOTION-CONNECT 500 MOTION-CONNECT 800PLUS
1.5 mm ²	50 m, 100 m, 200 m, 500 m (164 ft, 328 ft, 656 ft, 1641 ft)
2.5 mm ²	50 m, 100 m, 200 m, 500 m (164 ft, 328 ft, 656 ft, 1641 ft)

Variable length, sold by the meter

Cross-section	Brake cores	MOTION-CONNECT 500	MOTION-CONNECT 800PLUS
4 mm ²	without/with	≤ 500 m (1641 ft)	≤ 500 m (1641 ft)
6 mm ²	without/with	≤ 500 m (1641 ft)	≤ 500 m (1641 ft)
10 mm ²	without	≤ 500 m (1641 ft)	≤ 500 m (1641 ft)
	with	≤ 500 m (1641 ft)	≤ 100 m (328 ft)
16 mm ²	without/with	≤ 200 m (656 ft)	≤ 200 m (656 ft)
	without	≤ 200 m (656 ft)	–
25 mm ²	with	≤ 200 m (656 ft)	≤ 200 m (656 ft)
	without	≤ 200 m (656 ft)	–
35 mm ²	without	≤ 200 m (656 ft)	–
	with	≤ 200 m (656 ft)	≤ 200 m (656 ft)
50 mm ²	without	≤ 200 m (656 ft)	–
	with	≤ 200 m (656 ft)	≤ 200 m (656 ft)
70 mm ²	without	≤ 100 m (328 ft)	–

Connection system MOTION-CONNECT

Power cables for SINAMICS S110 and S120

Technical specifications

Power cables	MOTION-CONNECT 500 6FX500-.....-.....	MOTION-CONNECT 800PLUS 6FX800-.....-.....
Approvals, according to		
• VDE ¹⁾	Yes	Yes
• cURus or UR/CSA	UL758-CSA-C22.2-N.210.2-M90	UL758-CSA-C22.2-N.210.2-M90
• UR-CSA File No. ²⁾	Yes	Yes
• RoHS conformity	Yes	Yes
Rated voltage U_0/U in accordance with EN 50395		
• Power conductors	600 V/1000 V	600 V/1000 V
• Signal conductors	24 V (EN) 1000 V (UL/CSA)	24 V (EN) 1000 V (UL/CSA)
Test voltage, rms		
• Power conductors	4 kV	4 kV
• Signal conductors	2 kV	2 kV
Operating temperature on the surface		
• Fixed installation	-20 ... +80 °C (-4 ... +176 °F)	-50 ... +80 °C (-58 ... +176 °F)
• Flexible installation	0 ... 60 °C (32 ... 140 °F)	-20 ... +60 °C (-4 ... +140 °F)
Tensile stress, max.		
• Fixed installation	50 N/mm ² (7252 lb _f /in ²)	50 N/mm ² (7252 lb _f /in ²)
• Flexible installation	20 N/mm ² (2901 lb _f /in ²)	20 N/mm ² (2901 lb _f /in ²)
Smallest bending radius		
• Fixed installation	5 × D_{\max}	4 × D_{\max}
• Flexible installation	See power cables	See power cables
Torsional stress	Absolute 30°/m	Absolute 30°/m
Bending	100000	10 million
Traversing velocity	30 m/min (98.43 ft/min)	Up to 300 m/min (984 ft/min)
Acceleration	2 m/s ² (6.56 ft/s ²)	Up to 50 m/s ² (164 ft/s ²), see characteristic curves
Insulation material, incl. jacket	CFC/silicone-free	CFC/halogen/silicone-free IEC 60754-1/DIN VDE 0472-815
Oil resistance	EN 60811-2-1 (mineral oil only)	EN 60811-2-1
Outer jacket	PVC DESINA color orange RAL 2003	PUR, HD22.10 S2 (VDE 0282, Part 10) DESINA color orange RAL 2003
Flame-retardant	EN 60332-1-1 to 1-3	EN 60332-1-1 to 1-3

Degree of protection of the pre-assembled power cables and their extensions when closed and plugged: IP67.

¹⁾ The respective registration number is printed on the cable jacket (only applies to power cables).

²⁾ The file number is printed on the cable jacket.

Connection system MOTION-CONNECT

Power cables for SINAMICS S110 and S120

Power cables for 1FK7 motors with SPEED-CONNECT connector

Selection and ordering data

For 1FK7 motors without brake, with SPEED-CONNECT connector on SINAMICS S110 and S120 Power Modules

Connection method, Power Module end	No. of cores × cross-section mm ²	Connector size, motor end	Pre-assembled cable <u>without</u> brake cores	Cable sold by the meter ¹⁾ <u>without</u> brake cores	D_{max}	Weight (without connector)		Smallest perm. bending radius ²⁾		
			Order No.	Order No.		6FX5	6FX8	6FX5	6FX8	6FX5
					mm (in)	mm (in)	kg/m (lb/ft)	kg/m (lb/ft)	mm (in)	mm (in)
Exposed core ends	4 × 1.5	1	6FX 002-5CG10-....	6FX 008-1BB11-....	8.4 (0.33)	9.5 (0.37)	0.12 (0.08)	0.15 (0.10)	155 (6.10)	75 (2.95)
		1.5	6FX 002-5CG22-....							
	4 × 2.5	1	6FX 002-5CG12-....	6FX 008-1BB21-....	10 (0.39)	11 (0.43)	0.21 (0.14)	0.20 (0.13)	180 (7.09)	90 (3.54)
		1.5	6FX 002-5CG32-....							
	4 × 4	1.5	6FX 002-5CG42-....	6FX 008-1BB31-....	11.4 (0.45)	12.1 (0.48)	0.27 (0.18)	0.27 (0.18)	210 (8.27)	100 (3.94)
	4 × 6	1.5	6FX 002-5CG52-....	6FX 008-1BB41-....	13.6 (0.54)	14.9 (0.59)	0.37 (0.25)	0.41 (0.28)	245 (9.65)	120 (4.72)
4 × 10	1.5	6FX 002-5CG62-....	6FX 008-1BB51-....	20 (0.79)	18.2 (0.72)	0.73 (0.49)	0.62 (0.42)	360 (14.17)	140 (5.51)	
MOTION-CONNECT 500			5	5						
MOTION-CONNECT 800PLUS			8	8						
Length code								

For 1FK7 motors with brake, with SPEED-CONNECT connector on SINAMICS S110 and S120 Power Modules

Connection method, Power Module end	No. of cores × cross-section mm ²	Connector size, motor end	Pre-assembled cable <u>with</u> brake cores	Cable sold by the meter ¹⁾ <u>with</u> brake cores	D_{max}	Weight (without connector)		Smallest perm. bending radius ²⁾		
			Order No.	Order No.		6FX5	6FX8	6FX5	6FX8	6FX5
					mm (in)	mm (in)	kg/m (lb/ft)	kg/m (lb/ft)	mm (in)	mm (in)
Exposed core ends	4 × 1.5+2 × 1.5	0.5	6FX 002-5DN30-....	6FX 008-1BA11-....	10.8 (0.43)	12 (0.47)	0.22 (0.15)	0.16 (0.11)	195 (7.68)	90 (3.54)
		1	6FX 002-5DG10-....	6FX 008-1BA11-....	10.8 (0.43)	12 (0.47)	0.22 (0.15)	0.16 (0.11)	195 (7.68)	90 (3.54)
	4 × 1.5+2 × 1.5	1.5	6FX 002-5DG22-....							
		1	6FX 002-5DG12-....	6FX 008-1BA21-....	12.4 (0.49)	13.8 (0.54)	0.25 (0.17)	0.30 (0.20)	225 (8.86)	105 (4.13)
	4 × 2.5+2 × 1.5	1.5	6FX 002-5DG32-....							
	4 × 4+2 × 1.5	1.5	6FX 002-5DG42-....	6FX 008-1BA31-....	14.0 (0.55)	15.2 (0.60)	0.35 (0.24)	0.38 (0.26)	255 (10.04)	115 (4.53)
4 × 6+2 × 1.5	1.5	6FX 002-5DG52-....	6FX 008-1BA41-....	16.1 (0.63)	17.3 (0.68)	0.49 (0.33)	0.50 (0.34)	290 (11.42)	130 (5.12)	
4 × 10+2 × 1.5	1.5	6FX 002-5DG62-....	6FX 008-1BA51-....	21.7 (0.85)	20.1 (0.79)	0.81 (0.54)	0.71 (0.48)	395 (15.55)	150 (5.91)	
MOTION-CONNECT 500			5	5						
MOTION-CONNECT 800PLUS			8	8						
Length code								

¹⁾ Note type of delivery.

²⁾ Valid for installation in a cable carrier.

Connection system MOTION-CONNECT

Power cables for SINAMICS S110 and S120

Extensions for power cables with SPEED-CONNECT connector

Accessories

Extensions for power cables with SPEED-CONNECT connector

No. of cores × cross-section		Connector size, motor end	Basic cable for motors connected to SINAMICS S110 and S120 Power Modules	Extension
Without brake cores mm ²	With brake cores mm ²			
–	4 × 1.5 + 2 × 1.5	0.5	6FX5 002-5DN30-....	Order No. 6FX5 002-5MN05-....
4 × 1.5	4 × 1.5 + 2 × 1.5	1	6FX . 002-5 . G10-....	6FX 002-5 N05-....
		1.5	6FX . 002-5 . G22-....	6FX 002-5 Q28-....
4 × 2.5	4 × 2.5 + 2 × 1.5	1	6FX . 002-5 . G12-....	6FX 002-5 Q15-....
		1.5	6FX . 002-5 . G32-....	6FX 002-5 Q38-....
4 × 4	4 × 4 + 2 × 1.5	1.5	6FX . 002-5 . G42-....	6FX 002-5 Q48-....
4 × 6	4 × 6 + 2 × 1.5	1.5	6FX . 002-5 . G52-....	6FX 002-5 Q58-....
4 × 10	4 × 10 + 2 × 1.5	1.5	6FX . 002-5 . G61-....	6FX 002-5 A68-....
			6FX . 002-5 . G62-....	6FX 002-5 Q68-....
		3 ¹⁾	6FX . 002-5 . G13-....	6FX 002-5 X18-....
4 × 16	4 × 16 + 2 × 1.5	3 ¹⁾	6FX . 002-5 . G23-....	6FX 002-5 X28-....
–	4 × 25 + 2 × 1.5	3 ¹⁾	6FX . 002-5DG33-....	6FX 002-5DX38-....
–	4 × 35 + 2 × 1.5	3 ¹⁾	6FX . 002-5DG43-....	6FX 002-5DX48-....
–	4 × 50 + 2 × 1.5	3 ¹⁾	6FX . 002-5DG53-....	6FX 002-5DX58-....
MOTION-CONNECT 500		5		5
MOTION-CONNECT 800PLUS		8		8
Without brake cores				C
With brake cores				D
Length code			

The maximum specified cable length (basic cable and extensions) must not be exceeded.
For power cables with brake cores, the total maximum length is reduced by 2 m (6.56 ft) for each interruption point.

¹⁾ Connector at motor end with full-thread only.

Connection system MOTION-CONNECT

Power cables for SINAMICS S110 and S120

Power cables for 1PH8 motors
with terminal box

Selection and ordering data

For 1PH8 motors with terminal boxes on SINAMICS S110 and S120 Power Modules

Motor	Thread	No. of cores × cross-section	Connection method Power Module end	Pre-assembled cable	Cable sold by the meter ¹⁾	D_{max}	Weight (without thread)	Smallest perm. bending radius ²⁾			
Type		mm ²		Order No.	Order No.	mm (in)	kg/m (lb/ft)	mm (in)			
1PH808	M25	4 × 2.5	Exposed core ends ³⁾	6FX8002-5CR10-....	6FX8008-1BB21-....	11 (0.43)	0.20 (0.13)	90 (3.54)			
				–	6FX5008-1BB21-....	10 (0.39)	0.21 (0.14)	180 (7.09)			
				6FX8002-5CR20-....	6FX8008-1BB31-....	12.3 (0.48)	0.27 (0.18)	100 (3.94)			
		4 × 4		–	6FX5008-1BB31-....	11.4 (0.45)	0.27 (0.18)	210 (8.27)			
1PH810	M32	4 × 2.5	Exposed core ends ³⁾	6FX8002-5CR11-....	6FX8008-1BB21-....	11 (0.43)	0.20 (0.13)	90 (3.54)			
				–	6FX5008-1BB21-....	10 (0.39)	0.21 (0.14)	180 (7.09)			
				6FX8002-5CR21-....	6FX8008-1BB31-....	12.3 (0.48)	0.27 (0.18)	100 (3.94)			
				4 × 4		–	6FX5008-1BB31-....	11.4 (0.45)	0.27 (0.18)	210 (8.27)	
				4 × 10		6FX8002-5CR41-....	6FX8008-1BB51-....	18.2 (0.72)	0.62 (0.42)	140 (5.51)	
						–	6FX5008-1BB51-....	20 (0.79)	0.73 (0.49)	360 (14.17)	
1PH813	M40	4 × 10	Exposed core ends ³⁾	6FX8002-5CR42-....	6FX8008-1BB51-....	18.2 (0.72)	0.62 (0.42)	140 (5.51)			
				–	6FX5008-1BB51-....	20 (0.79)	0.73 (0.49)	360 (14.17)			
					6FX8002-5CR43-....						
					–						
			4 × 16		6FX8002-5CR52-....	6FX8008-1BB61-....	22.3 (0.88)	1.01 (0.68)	170 (6.69)		
	–	6FX5008-1BB61-....			24.2 (0.95)	1.10 (0.74)	440 (17.32)				
					6FX8002-5CR53-....						
					–						
			4 × 35		6FX5002-5CR72-....	6FX5008-1BB35-....	31.5 (1.24)	1.93 (1.3)	570 (22.44)		
					6FX5002-5CR73-....	6FX8008-1BA35-....					
		4 × 50		6FX5002-5CR83-....	6FX5008-1BB50-....	38 (1.50)	3.04 (2.04)	685 (26.97)			
				–	6FX8008-1BA50-....						
1PH816	M50	4 × 16	Exposed core ends ³⁾	6FX8002-5CR53-....	6FX8008-1BB61-....	22.3 (0.88)	1.01 (0.68)	170 (6.69)			
				–	6FX5008-1BB61-....	24.2 (0.95)	1.10 (0.74)	440 (17.32)			
				6FX5002-5CR73-....	6FX5008-1BB35-....	31.5 (1.24)	1.93 (1.3)	570 (22.44)			
			4 × 35		6FX5002-5CR83-....	6FX5008-1BB50-....	38 (1.50)	3.04 (2.04)	685 (26.97)		
					–	6FX8008-1BA50-....					
			4 × 25		–	6FX5008-1BB25-....	28 (1.10)	1.62 (1.09)	505 (19.88)		
					–	6FX8008-1BA25-....					
					4 × 35		–	6FX5008-1BB35-....	31.5 (1.24)	1.93 (1.3)	570 (22.44)
							–	6FX8008-1BA35-....			
			4 × 50		–	6FX5008-1BB50-....	38 (1.50)	3.04 (2.04)	685 (26.97)		
		–			6FX8008-1BA50-....						
		4 × 70		–	6FX5008-1BB70-....	42.6 (1.68)	3.96 (2.66)	770 (30.31)			
MOTION-CONNECT 500				5							
MOTION-CONNECT 800PLUS				8							
Length code										

¹⁾ Note type of delivery.

²⁾ Valid for installation in a cable carrier.

³⁾ Length of core ends: 300 mm (11.81 in). 4 M8 cable lugs and 4 M6 cable lugs are also included in the scope of delivery of the cables.

Connection system MOTION-CONNECT

Signal cables for SINAMICS S110 and S120

Overview



MOTION-CONNECT DRIVE-CLiQ signal cable with IP20/IP67 connector
Signal cables are pre-assembled and are sold by the meter for the connection of a variety of components.

The following different types of cable are available:

- DRIVE-CLiQ signal cables
- MOTION-CONNECT DRIVE-CLiQ signal cables
- Pre-assembled MOTION-CONNECT signal cables

Type of delivery of pre-assembled signal cables

Pre-assembled signal cables can be ordered in length units of 10 cm (3.94 in).

Cables up to 30 kg (66.2 lb) or 100 m (328 ft) are supplied as coils; above this, they are supplied on drums.

Application

DRIVE-CLiQ signal cables

are used to connect components with DRIVE-CLiQ connections which have a separate or external 24 V DC power supply.

MOTION-CONNECT DRIVE-CLiQ signal cables

are used whenever components with DRIVE-CLiQ connections must meet high requirements, such as mechanical stress and oil resistance, e.g. in the event of a connection outside the cabinet between

- Motor Modules and Sensor Modules
- Motor Modules and motors with DRIVE-CLiQ interface

MOTION-CONNECT DRIVE-CLiQ signal cables have 24 V DC cores.

Pre-assembled MOTION-CONNECT signal cables

are used whenever motor encoders on motors without DRIVE-CLiQ interface are connected to Sensor Modules.

If pre-assembled signal cables are installed in a cable carrier in such a way that the connector would inhibit assembly, pre-assembled cables without assembled connectors can also be supplied. In this case, the contacts of the cables are crimped and the connector enclosure is supplied separately. After installing the cables, the customer assembles the connector enclosure.

All 6FX.002-2C...-.... signal cables are available with crimped contacts and with the connector enclosure supplied separately (not in the case of DRIVE-CLiQ signal cables).

Signal cables with separately supplied connector enclosure **for the motor end**. In this case, the 6th position of the Order No. must be changed from **0** to **4**:
6FX.042-2C...-....

Signal cables with separately supplied connector enclosure **for the module end**. In this case, the 6th position of the Order No. must be changed from **0** to **1**:
6FX.012-2C...-....

Note:

Once the contacts have latched into the insulator, they can no longer be removed.

Connection system MOTION-CONNECT

Signal cables for SINAMICS S110 and S120

Technical specifications

DRIVE-CLiQ signal cables	DRIVE-CLiQ	DRIVE-CLiQ MOTION-CONNECT 500	DRIVE-CLiQ MOTION-CONNECT 800PLUS
	6FX2...-1DC...-....	6FX5...-DC...-....	6FX8...-DC...-....
Approvals, according to			
• cURus or UR/CSA	UL STYLE 2502/CSA-N.210.2-M90	UL STYLE 2502/CSA-N.210.2-M90	UL STYLE 2502/CSA-N.210.2-M90
• UR-CSA File No. ¹⁾	Yes	Yes	Yes
• RoHS conformity	Yes	Yes	Yes
Rated voltage according to EN 50395	30 V	30 V	30 V
Test voltage, rms	500 V	500 V	500 V
Operating temperature on the surface			
• Fixed installation	-20 ... +80 °C (-4 ... +176 °F)	-20 ... +80 °C (-4 ... +176 °F)	-20 ... +80 °C (-4 ... +176 °F)
• Flexible installation	–	0 ... 60 °C (32 ... 140 °F)	-20 ... +60 °C (-4 ... +140 °F)
Tensile stress, max.			
• Fixed installation	45 N/mm ² (6526 lb _f /in ²)	80 N/mm ² (11603 lb _f /in ²)	50 N/mm ² (7252 lb _f /in ²)
• Flexible installation	–	30 N/mm ² (4351 lb _f /in ²)	20 N/mm ² (2901 lb _f /in ²)
Smallest bending radius			
• Fixed installation	50 mm (1.97 in)	35 mm (1.38 in)	35 mm (1.38 in)
• Flexible installation	–	125 mm (4.92 in)	75 mm (2.95 in)
Torsional stress	–	Absolute 30°/m	Absolute 30°/m
Bending	–	100000	10 million
Traversing velocity	–	30 m/min (98.4 ft/min)	300 m/min (984 ft/min)
Acceleration	–	2 m/s ² (6.56 ft/s ²)	Up to 50 m/s ² (164 ft/s ²), see characteristic curves
Insulation material, incl. jacket	CFC/silicone-free	CFC/silicone-free	CFC/halogen/silicone-free IEC 60754-1/DIN VDE 0472-815
Oil resistance	EN 60811-2-1	EN 60811-2-1 (mineral oil only)	EN 60811-2-1
Outer jacket	PVC	PVC	PUR, HD22.10 S2 (VDE 0282, Part 10)
	Gray RAL 7032	DESINA color green RAL 6018	DESINA color green RAL 6018
Flame-retardant	EN 60332-1-1 to 1-3	EN 60332-1-1 to 1-3	EN 60332-1-1 to 1-3

Degree of protection of the pre-assembled signal cables and their extensions when closed and plugged: IP67.

¹⁾ The file number is printed on the cable jacket.

Connection system MOTION-CONNECT

Signal cables for SINAMICS S110 and S120

Technical specifications (continued)

Signal cables	MOTION-CONNECT 500 6FX500.-.....-.....	MOTION-CONNECT 800PLUS 6FX800.-.....-.....
Approvals, according to		
• cURus or UR/CSA	UL758-CSA-C22.2-N.210.2-M90	UL758-CSA-C22.2-N.210.2-M90
• UR-CSA File No. ¹⁾	Yes	Yes
• RoHS conformity	Yes	Yes
Rated voltage according to EN 50395	30 V	30 V
Test voltage, rms	500 V	500 V
Operating temperature on the surface		
• Fixed installation	-20 ... +80 °C (-4 ... +176 °F)	-50 ... +80 °C (-58 ... +176 °F)
• Flexible installation	0 ... 60 °C (32 ... 140 °F)	-20 ... +60 °C (-4 ... +140 °F)
Tensile stress, max.		
• Fixed installation	50 N/mm ² (7252 lb _f /in ²)	50 N/mm ² (7252 lb _f /in ²)
• Flexible installation	20 N/mm ² (2901 lb _f /in ²)	20 N/mm ² (2901 lb _f /in ²)
Smallest bending radius		
• Fixed installation	60 mm (2.36 in)	4 × D _{max}
• Flexible installation	100 mm (3.94 in)	See signal cables
Torsional stress	Absolute 30°/m	Absolute 30°/m
Bending	2 million	10 million
Traversing velocity	180 m/min (591 ft/min)	Up to 300 m/min (984 ft/min)
Acceleration	5 m/s ² (16.41 ft/s ²)	Up to 50 m/s ² (164 ft/s ²), see characteristic curves
Insulation material, incl. jacket	CFC/silicone-free	CFC/halogen/silicone-free IEC 60754-1/DIN VDE 0472-815
Oil resistance	EN 60811-2-1 (mineral oil only)	EN 60811-2-1
Outer jacket	PVC DESINA color green RAL 6018	PUR, HD22.10 S2 (VDE 0282, Part 10) DESINA color green RAL 6018
Flame-retardant	EN 60332-1-1 to 1-3	EN 60332-1-1 to 1-3

Degree of protection of the pre-assembled signal cables and their extensions when closed and plugged: IP67.

¹⁾ The file number is printed on the cable jacket.



Connection system MOTION-CONNECT

Signal cables for SINAMICS S110 and S120

**DRIVE-CLiQ signal cables
without 24 V DC cores**

Selection and ordering data

Pre-assembled DRIVE-CLiQ signal cables without 24 V DC cores

Type	Length	D_{max}	Degree of protection	DRIVE-CLiQ signal cable
	m (ft)	mm (in)	Connector	without 24 V DC cores
				Order No.
	Fixed lengths		IP20/IP20	6SL3060-4AB00-0AA0
	0.11 (0.36)			6SL3060-4AD00-0AA0
	0.16 (0.52)			6SL3060-4AF00-0AA0
	0.21 (0.69)			6SL3060-4AH00-0AA0
	0.26 (0.85)			6SL3060-4AK00-0AA0
	0.31 (1.02)			6SL3060-4AM00-0AA0
	0.36 (1.18)			6SL3060-4AP00-0AA0
	0.41 (1.35)			6SL3060-4AU00-0AA0
	0.60 (1.97)			6SL3060-4AA10-0AA0
	0.95 (3.12)			6SL3060-4AW00-0AA0
	1.20 (3.94)			6SL3060-4AF10-0AA0
1.45 (4.76)			6SL3060-4AJ20-0AA0	
2.80 (9.19)			6SL3060-4AA50-0AA0	
5.00 (16.41)				
To the meter	max. 70 (230)	7.0 (0.28)	IP20/IP20	6FX2002-1DC00-....
				
To the meter	max. 70 (230)	7.0 (0.28)	IP67/IP67	6FX2002-1DC20-....
				
Length code			



Connection system MOTION-CONNECT

Signal cables for SINAMICS S110 and S120

MOTION-CONNECT DRIVE-CLiQ signal cables with 24 V DC cores

Selection and ordering data (continued)

Pre-assembled MOTION-CONNECT DRIVE-CLiQ signal cables with 24 V DC cores

Type	Application	Length, max.	D_{max}	Degree of protection Connector	MOTION-CONNECT DRIVE-CLiQ signal cable with 24 V DC cores Order No.
		m (ft)	mm (in)		
To the meter 	For components with DRIVE-CLiQ interface in the control cabinet, e.g. SINAMICS S120 Power Modules	100 (328)	7.1 (0.28)	IP20/IP20	6FX5002-2DC00-....
		75 (246)	7.1 (0.28)	IP20/IP20	6FX8002-2DC00-....
To the meter 	For encoder systems with DRIVE-CLiQ, built into or onto 1FK7/1PH8 motors For connecting the motors to SINAMICS S120 Power Modules	100 (328)	7.1 (0.28)	IP20/IP67	6FX5002-2DC10-....
		75 (246)	7.1 (0.28)	IP20/IP67	6FX8002-2DC10-....
To the meter 	For encoder systems with DRIVE-CLiQ, built into or onto 1FK7/1PH8 motors For the connection between motors	100 (328)	7.1 (0.28)	IP67/IP67	6FX5002-2DC20-....
		75 (246)	7.1 (0.28)	IP67/IP67	6FX8002-2DC20-....
MOTION-CONNECT 500					5
MOTION-CONNECT 800PLUS					8
Length code				

Connection system MOTION-CONNECT

Signal cables for SINAMICS S110 and S120

Signal cables for motors
with SPEED-CONNECT/full-thread connector

Selection and ordering data (continued)

Pre-assembled MOTION-CONNECT signal cables for motors with SPEED-CONNECT connector

Encoder system	Motor type	Connection via	Length, max.		Degree of protection Connector	Basic cable		Extension	
			m (ft)	mm (in)		Order No.	Order No.		
Incremental encoder sin/cos 1 V _{pp} 2048 S/R	1FK701	SMC20	50 (164)	9.2 (0.36)	IP20/IP67	6FX 002-2CN20-....	6FX 8002-2CN24-....		
Incremental encoder sin/cos 1 V _{pp} 2048 S/R, with C and D tracks	1FK7 ¹⁾	SMC20	100 (328)	9.8 (0.39)	IP20/IP67	6FX 002-2CQ31-....	6FX 002-2CQ34-....		
Absolute encoder with EnDat	1FK701	SMC20	50 (164)	9.8 (0.39)	IP20/IP67	6FX 002-2EN20-....	6FX 8002-2EN24-....		
Absolute encoder with EnDat	1FK7 ¹⁾	SMC20	100 (328)	9.8 (0.39)	IP20/IP67	6FX 002-2EQ31-....	6FX 002-2EQ34-....		
Resolver									
• Multi-pole	1FK701	SMC10	50 (164)	9.2 (0.36)	IP20/IP67	6FX 002-2CN20-....	6FX 8002-2CN24-....		
• 2-pole	1FK701	SMC10	130 (427)	9.2 (0.36)	IP20/IP67	6FX 002-2CN20-....	6FX 8002-2CN24-....		
MOTION-CONNECT 500						5		5	
MOTION-CONNECT 800PLUS						8		8	
Length code						

Pre-assembled MOTION-CONNECT signal cables for motors with full-thread connector

Encoder system	Motor type	Connection via	Length, max.		Degree of protection Connector	Basic cable		Extension	
			m (ft)	mm (in)		Order No.	Order No.		
Absolute encoder with SSI 6FX2001-5.S 24 V DC, clock-pulse rate 100 ... 250 kHz		SMC30 CU310-2	100 (328)	9.3 (0.37)	IP20/IP67	6FX 002-2CC11-....	6FX 002-2CB54-....		
Absolute encoder with EnDat 6FX2001-5.E		SMC20	100 (328)	9.2 (0.36)	IP20/IP67	6FX 002-2CH00-....	6FX 002-2AD04-....		
Resolver									
• Multi-pole	1FK7 ¹⁾	SMC10	50 (164)	9.2 (0.36)	IP20/IP67	6FX 002-2CF02-....	6FX 002-2CF04-....		
• 2-pole	1FK7 ¹⁾	SMC10	130 (427)	9.2 (0.36)	IP20/IP67	6FX 002-2CF02-....	6FX 002-2CF04-....		
HTL incremental encoder	1PH8	SMC30	300 (984) ²⁾	9.3 (0.37)	IP20/IP67	6FX 002-2AH00-....	6FX 002-2AH04-....		
HTL incremental encoder 5 V DC	1PH8	CU310-2	100 (328)	9.3 (0.37)	IP20/IP67	6FX 002-2AH11-....	–		
HTL incremental encoder 24 V DC 6FX2001-4		SMC30	100 (328)	9.3 (0.37)	–/IP67	6FX 5002-2CA12-....	–		
TTL incremental encoder RS422 6FX2001-2									
• 5 V DC		SMC30 CU310-2	100 (328)	9.3 (0.37)	IP20/IP67	6FX 002-2CR00-....	6FX 002-2CB54-....		
• 24 V DC		SMC30 CU310-2	100 (328)	9.3 (0.37)	IP20/IP67	6FX 002-2CD24-....	6FX 002-2CB54-....		
HTL incremental encoder 5 V DC	1LA	CU310-2	100 (328)	8.0 (0.31)	IP20/IP67	6SX 7002-0AN30-....	–		
HTL incremental enc. 1XP8001-1	1LA								
• Signals A, B		SMC30	100 (328)	6.3 (0.25)	IP20/IP67	6SX 7002-0AL00-....	–		
• Signals A*, A, B*, B, R*, R		SMC30	300 (984) ²⁾	8.0 (0.31)	IP20/IP67	6SX 7002-0AN00-....	–		
• Signals A*, A, B*, B, R*, R with right-angled connector		SMC30	300 (984) ²⁾	8.0 (0.31)	IP20/IP67	6SX 7002-0AN10-....	–		
Incremental encoder sin/cos 1 V _{pp} 6FX2001-3		SMC20	50 (164)	9.3 (0.37)	IP20/IP67	6FX 002-2CG00-....	6FX 002-2CB54-....		
MOTION-CONNECT 500						5		5	
MOTION-CONNECT 800PLUS						8		8	
Length code						

The combinations of signal cable extensions shown are only provided by way of example.

The maximum specified cable length (basic cable and extensions) must not be exceeded. The total maximum length is reduced by 2 m (6.56 ft) for each interruption point.

¹⁾ Not for 1FK701 motors.

²⁾ With evaluation of difference signals A*, A, B*, B, otherwise ≤ 100 m (328 ft).

Connection system MOTION-CONNECT

Connection overviews

Integration

Connection overview of SINAMICS S110 and S120 Power Modules in blocksize format with CU310-2 Control Unit for motors with/without DRIVE-CLiQ interface

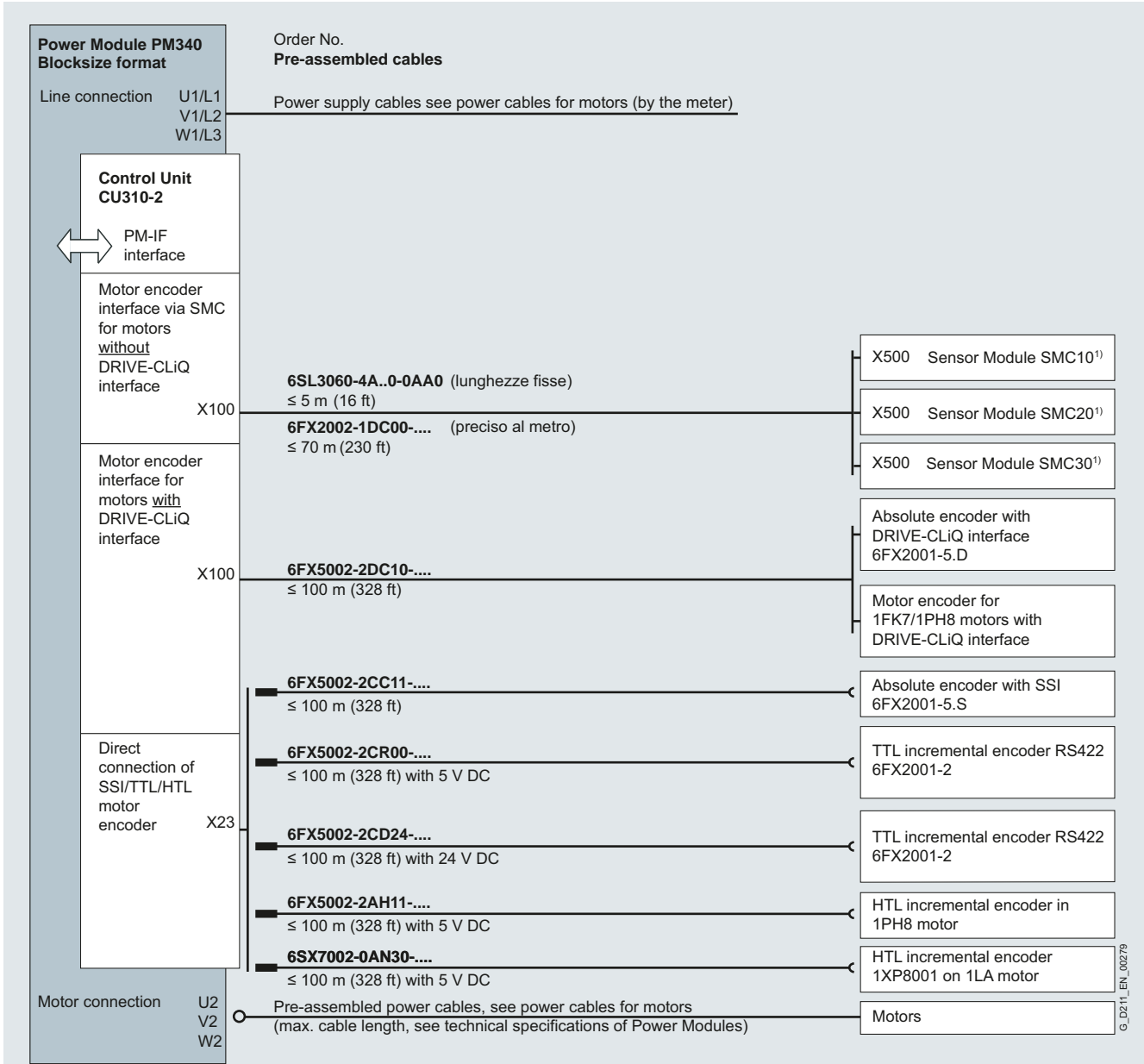

G_D211_EN_00279

¹⁾ See connection overviews for SMC10/SMC20/SMC30.

Integration (continued)

Connection overview for SINAMICS S110 and S120 SMC10 Sensor Module Cabinet-Mounted

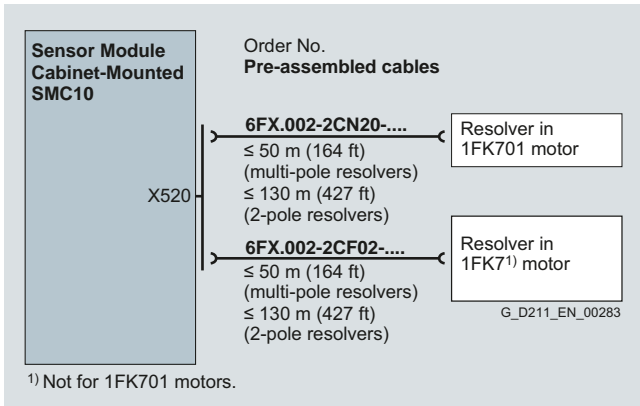

Connection overview for SINAMICS S110 and S120 SMC20 Sensor Module Cabinet-Mounted

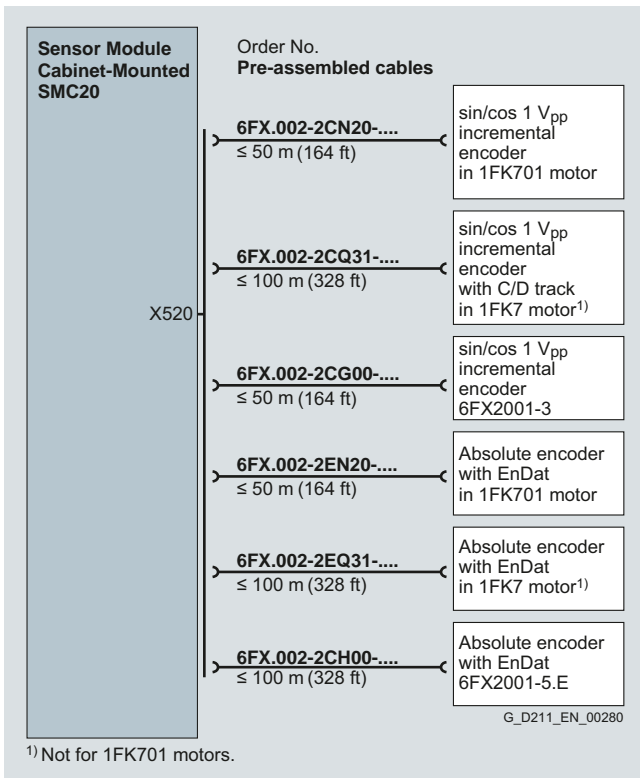

Connection overview for SINAMICS S110 and S120 SMC30 Sensor Module Cabinet-Mounted

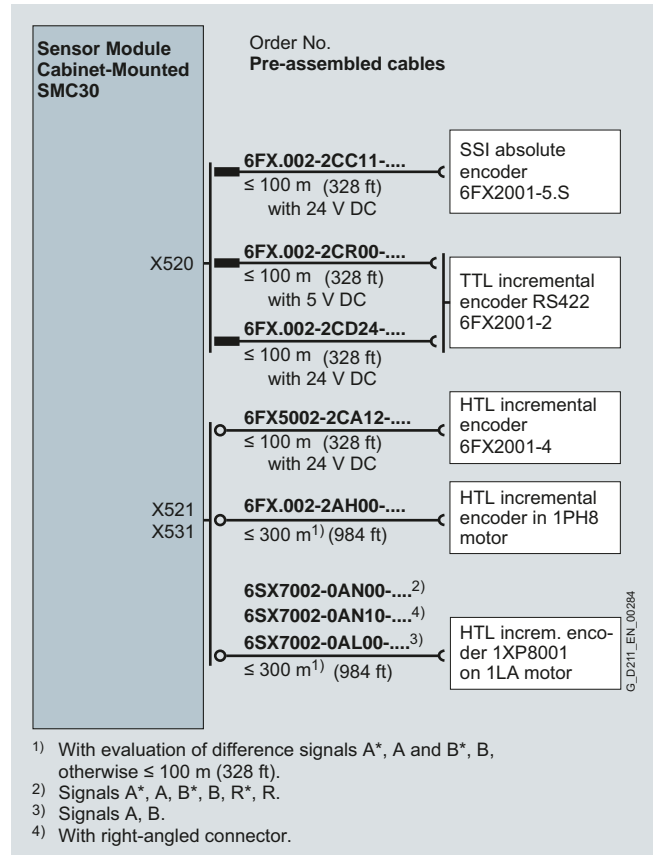

Connection system MOTION-CONNECT

Length code

Overview

Description Order No. supplement

Length code for pre-assembled cables

6FX.....-.....- ■ ■ ■ ■ ■
6SX.....-.....- ■ ■ ■ ■ 0

0 m (0 ft)	1				
100 m (328 ft)	2				
200 m (656 ft)	3				
0 m (0 ft)		A			
10 m (32.8 ft)		B			
20 m (65.6 ft)		C			
30 m (98.4 ft)		D			
40 m (131 ft)		E			
50 m (164 ft)		F			
60 m (197 ft)		G			
70 m (230 ft)		H			
80 m (262 ft)		J			
90 m (295 ft)		K			
0 m (0 ft)		A			
1 m (3.28 ft)		B			
2 m (6.56 ft)		C			
3 m (9.84 ft)		D			
4 m (13.1 ft)		E			
5 m (16.4 ft)		F			
6 m (19.7 ft)		G			
7 m (22.9 ft)		H			
8 m (26.3 ft)		J			
9 m (29.5 ft)		K			
0 m (0 ft)					0
0.1 m (3.94 in)					1
0.2 m (7.87 in)					2
0.3 m (11.81 in)					3
0.4 m (15.75 in)					4
0.5 m (19.96 in)					5
0.6 m (23.62 in)					6
0.7 m (27.56 in)					7
0.8 m (31.5 in)					8

Examples: 1.0 m (3.28 ft): 1 A B 0
2.2 m (7.22 ft): 1 A C 2
8.0 m (26.3 ft): 1 A J 0
299.0 m (981 ft): 3 K K 0

Description Order No. supplement

Length code for power and signal cables, sold by the meter¹⁾

6FX.008-.....- ■ ■ ■ A 0

50 m (164 ft)	1	F		
100 m (328 ft)	2	A		
200 m (656 ft)	3	A		
500 m (1641 ft)	6	A		

More information

Definition of lengths for pre-assembled cables

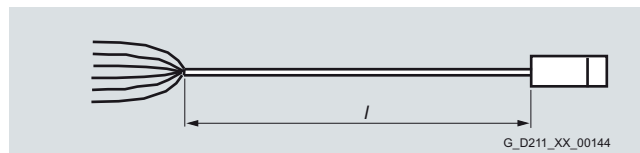

Cable with exposed core ends and pre-assembled connector

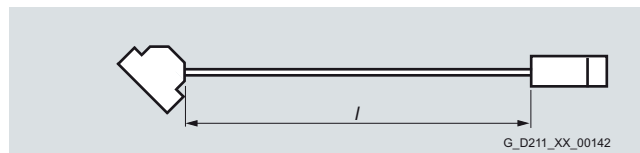

Cable with pre-assembled connectors at both ends

Tolerances:

- Cable lengths up to 10 m (32.8 ft): $\pm 2\%$
- Cable lengths of 10 m (32.8 ft) and longer: $\pm 1\%$

¹⁾ Note type of delivery.