

Mechanically held lighting contactor, Contactor amp rating 30Amp
 0NC _ 8NO poles, 440VAC 50HZ/480VAC 60HZ coil, Non-
 combination type, Enclosure NEMA type open, No enclosure



Figure similar

| | |
|-------------------------|---|
| Product brand name | Class CLM |
| Design of the product | Magnetically latched lighting contactor |
| Special product feature | Energy efficient; Quiet operation |

| General technical data | |
|--|--------------------|
| Weight [lb] | 9 lb |
| Height x Width x Depth [in] | 5.87 × 8 × 4.86 in |
| Protection against electrical shock | Not finger-safe |
| Installation altitude [ft] at height above sea level maximum | 6560 ft |
| Country of origin | USA |

| Contactor | |
|---|----------|
| Size of contactor | 30 Amp |
| Number of NO contacts for main contacts | 8 |
| Number of NC contacts for main contacts | 0 |
| Operating voltage for main current circuit at AC at 60 Hz maximum | 600 V |
| Mechanical service life (switching cycles) of the main contacts typical | 10000000 |

| | |
|--|---|
| Contact rating of the main contacts of lighting contactor | |
| <ul style="list-style-type: none"> • at tungsten (1 pole per 1 phase) rated value • at tungsten (2 poles per 1 phase) rated value • at tungsten (3 poles per 3 phases) rated value • at ballast (1 pole per 1 phase) rated value • at ballast (2 poles per 1 phase) rated value • at ballast (3 poles per 3 phases) rated value • at resistive load (1 pole per 1 phase) rated value • at resistive load (2 poles per 1 phase) rated value • at resistive load (3 poles per 3 phases) rated value | <p>30A @277V 1p 1ph</p> <p>30A @480V 2p 1ph</p> <p>30A @480V 3p 3ph</p> <p>30A @347V 1p 1ph</p> <p>30A @600V 2p 1ph</p> <p>30A @600V 3p 3ph</p> <p>30A @347V 1p 1ph</p> <p>30A @600V 2p 1ph</p> <p>30A @600V 3p 3ph</p> |

| Auxiliary contact | |
|---|----|
| Number of NC contacts for auxiliary contacts | 0 |
| Number of NO contacts for auxiliary contacts | 0 |
| Number of total auxiliary contacts maximum | 4 |
| Contact rating of auxiliary contacts of contactor according to UL | NA |

| Coil | |
|--|---------------------------|
| Type of voltage of the control supply voltage | AC |
| Control supply voltage | |
| <ul style="list-style-type: none"> • at AC at 50 Hz rated value • at AC at 60 Hz rated value | <p>440 V</p> <p>480 V</p> |
| Apparent pick-up power of magnet coil at AC | 820 V·A |
| Apparent holding power of magnet coil at AC | 80 V·A |
| Operating range factor control supply voltage rated value of magnet coil | 0.85 ... 1.1 |

| Enclosure | |
|---|----------------------------|
| Degree of protection NEMA rating of the enclosure | Open device (no enclosure) |
| Design of the housing | NA |

| Mounting/wiring | |
|--|-----------------------------------|
| Mounting position | Vertical |
| Mounting type | Surface mounting and installation |
| Type of electrical connection for supply voltage line-side | Screw-type terminals |
| Tightening torque [lbf·in] for supply | 18 ... 20 lbf·in |
| Type of connectable conductor cross-sections at line-side at AWG conductors single or multi-stranded | 2x (14 ... 8 AWG) |
| Temperature of the conductor for supply maximum permissible | 75 °C |

| | |
|---|----------------------|
| Material of the conductor for supply | CU |
| Type of electrical connection for load-side outgoing feeder | Screw-type terminals |
| Tightening torque [lbf·in] for load-side outgoing feeder | 18 ... 20 lbf·in |
| Type of connectable conductor cross-sections at AWG conductors for load-side outgoing feeder single or multi-stranded | 2x (14 ... 8 AWG) |
| Temperature of the conductor for load-side outgoing feeder maximum permissible | 75 °C |
| Material of the conductor for load-side outgoing feeder | CU |
| Type of electrical connection of magnet coil | Screw-type terminals |
| Tightening torque [lbf·in] at magnet coil | 8 ... 12 lbf·in |
| Type of connectable conductor cross-sections of magnet coil at AWG conductors single or multi-stranded | 2x (16 ... 12 AWG) |
| Temperature of the conductor at magnet coil maximum permissible | 75 °C |
| Material of the conductor at magnet coil | CU |

Short-circuit current rating

| | |
|--|----------------------------------|
| Design of the fuse link for short-circuit protection of the main circuit required | none |
| Design of the short-circuit trip | Thermal magnetic circuit breaker |
| Maximum short-circuit current breaking capacity (Icu) <ul style="list-style-type: none"> • at 240 V • at 480 V • at 600 V | 5 kA 5 kA 5 kA |
| Certificate of suitability | NEMA ICS 2; UL 508A |

Further information

Industrial Controls - Product Overview (Catalogs, Brochures,...)

www.usa.siemens.com/iccatalog

Industry Mall (Online ordering system)

<https://mall.industry.siemens.com/mall/en/us/Catalog/product?mlfb=US2:CLM0C08480>

Service&Support (Manuals, Certificates, Characteristics, FAQs,...)

<https://support.industry.siemens.com/cs/US/en/ps/US2:CLM0C08480>

Image database (product images, 2D dimension drawings, 3D models, device circuit diagrams, EPLAN macros, ...)

http://www.automation.siemens.com/bilddb/cax_de.aspx?mlfb=US2:CLM0C08480&lang=en

Certificates/approvals

<https://support.industry.siemens.com/cs/US/en/ps/US2:CLM0C08480/certificate>

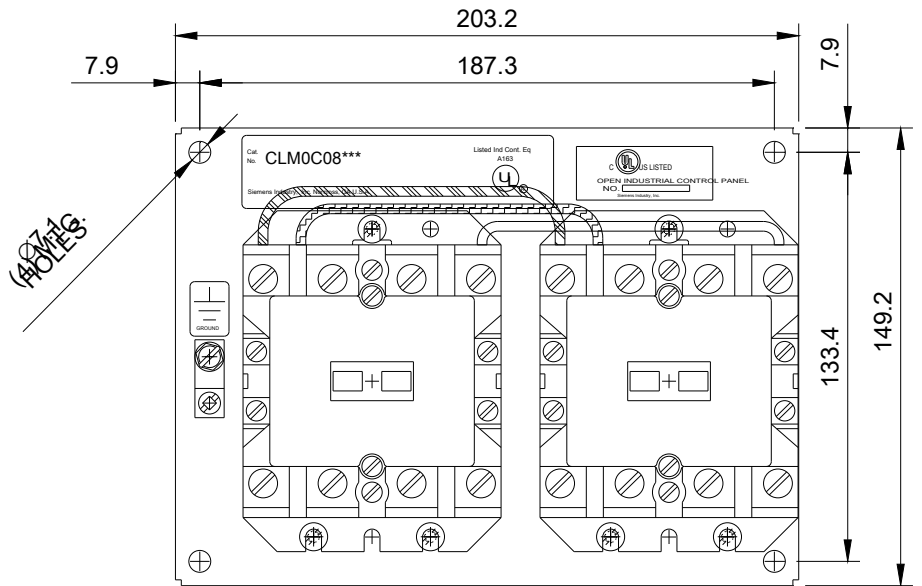
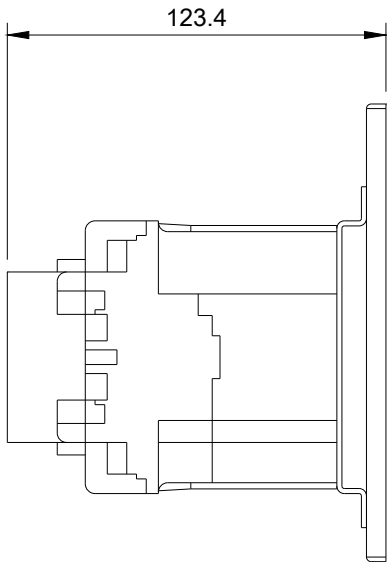

Wiring Diagram Class CLM
30-60 Amp 8 Pole

To
Control
Devices

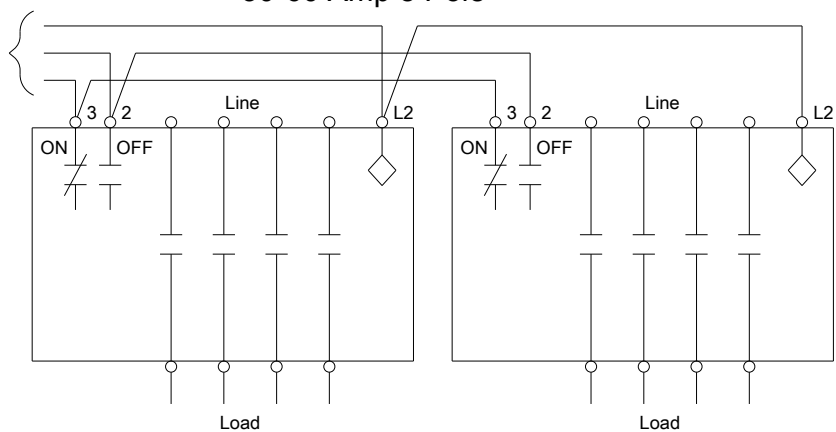

Optional auxiliary contacts are not shown.

E87010-A0410-T009-A1-CLM-3

last modified:

11/28/2019