

# SIEMENS

Elektronischer Überstromauslöser LCD ETU

Electronic Trip Unit LCD ETU

Déclencheur électronique LCD

Disparador por sobretensión electrónico LCD

Sganciatore di sovracorrente elettronico LCD

Disparador de sobrecorrente eletrônico LCD ETU

Elektronik fazla akım rölesi LCD ETU

Электронный расцепитель максимального тока LCD ETU

电子式过电流断路器 LCD/ETU

U.S. Cat. No.

CDT3A

CDT3G

CDT3K



CFT3A

CFT3G

CFT3K

For use with Frame DG, FG  
Para usar con caja Base DG, FG

Betriebsanleitung Instruções de Serviço	Operating Instructions İşletme kılavuzu	Instructions de service Инструкция по эксплуатации	Instructivo 使用说明	Istruzioni operative
--	--	---	---------------------	----------------------

Deutsch	English	Français
Vor der Installation, dem Betrieb oder der Wartung des Geräts muss diese Anleitung gelesen und verstanden werden.	Read and understand these instructions before installing, operating, or maintaining the equipment.	Ne pas installer, utiliser ou intervenir sur cet équipement avant d'avoir lu et assimilé les présentes instructions et notamment les conseils de sécurité et mises en garde qui y figurent.
<b>▲ GEFAHR</b>	<b>▲ DANGER</b>	<b>▲ DANGER</b>
 <b>Gefährliche Spannung. Lebensgefahr oder schwere Verletzungsfahr.</b> Vor Beginn der Arbeiten Anlage und Gerät spannungsfrei schalten.	<b>Hazardous voltage. Will cause death or serious injury.</b> Turn off and lock out all power supplying this device before working on this device.	<b>Tension électrique. Danger de mort ou risque de blessures graves.</b> Mettre hors tension avant d'intervenir sur l'appareil.
<b>VORSICHT</b>	<b>CAUTION</b>	<b>PRUDENCE</b>
Eine sichere Gerätefunktion ist nur mit zertifizierten Komponenten gewährleistet.	Reliable functioning of the equipment is only ensured with certified components.	La sécurité de fonctionnement de l'appareil n'est garantie qu'avec des composants certifiés.
Español	Italiano	Português
Leer y comprender este instructivo antes de la instalación, operación o mantenimiento del equipo.	Leggere con attenzione queste istruzioni prima di installare, utilizzare o eseguire manutenzione su questa apparecchiatura.	Ler e compreender estas instruções antes da instalação, operação ou manutenção do equipamento.
<b>▲ PELIGRO</b>	<b>▲ PERICOLO</b>	<b>▲ PERIGO</b>
 <b>Tensión peligrosa. Puede causar la muerte o lesiones graves.</b> Desconectar la alimentación eléctrica antes de trabajar en el equipo.	<b>Tensione pericolosa. Può provocare morte o lesioni gravi.</b> Scollegare l'alimentazione prima di eseguire interventi sull'apparechiatura.	<b>Tensão perigosa. Perigo de morte ou ferimentos graves.</b> Desligue a alimentação elétrica e proteja contra o religamento, antes de iniciar o trabalho no equipamento.
<b>PRECAUCIÓN</b>	<b>CAUTELA</b>	<b>CAUTION</b>
El funcionamiento seguro del aparato sólo está garantizado con componentes certificados.	Il funzionamento sicuro dell'apparechiatura è garantito soltanto con componenti certificati.	O funcionamento seguro do aparelho apenas pode ser garantido se forem utilizados os componentes certificados.
Türkçe	Русский	中文
Cihazın kurulumundan, çalıştırılmasından veya bakıma tabi tutulmasından önce, bu kılavuzun okunmuş ve anlaşılması gerekmektedir.	Перед установкой, вводом в эксплуатацию или обслуживанием устройства необходимо прочесть и понять данное руководство.	安装、使用和维修本设备前必须先阅读并理解本说明。
<b>▲ TEHLİKE</b>	<b>▲ ОПАСНО</b>	<b>▲ 危险</b>
 <b>Tehlikeli gerilim. Ölüm tehlikesi veya ağır yaralanma tehlikesi.</b> Çalışmalara başlamadan önce, sistemin ve cihazın gerilim beslemesini kapatınız.	<b>Опасное напряжение. Опасность для жизни или возможность тяжелых травм.</b> Перед началом работ отключить подачу питания к установке и к устройству.	<b>危险电压。可能导致生命危险或重伤危险。</b> 操作设备时必须确保切断电源。
<b>ÖNEMLİ DİKKAT</b>	<b>ОСТОРОЖНО</b>	<b>小心</b>
Cihazın güvenli çalışması ancak sertifikalı bileşenler kullanılması halinde garanti edilebilir.	Безопасность работы устройства гарантируется только при использовании сертифицированных компонентов.	只有使用经过认证的部件才能保证设备的正常运转。

Technical Support: Internet: <http://www.siemens.com/lowvoltage/technical-support>

**NOTE**

These instructions do not purport to cover all details or variations in equipment, or to provide for every possible contingency to be met in connection with installation, operation or maintenance. Should further information be desired or should particular problems arise, which are not covered sufficiently for the purchaser's purposes, the matter should be referred to the local Siemens sales office. The contents of this Instruction manual shall not become part of or modify any prior or existing agreement, commitment or relationship. The sales contract contains the entire obligation of Siemens. The warranty contained in the contract between the parties is the sole warranty of Siemens. Any statements contained herein do not create new warranties or modify the existing warranty.

Trademarks - Unless otherwise noted, all names identified by © are registered trademarks of Siemens AG or Siemens Industry, Inc. The remaining trademarks in this publication may be trademarks whose use by third parties for their own purposes could violate the rights of the owner.

DE	Notwendige Werkzeuge für Montage
EN	Necessary assembly tools
FR	Outils nécessaires pour le montage
ES	Herramientas requeridas para el montaje
IT	Utensili necessari per il montaggio
PT	Ferramentas necessárias para a montagem
TR	Montaj için gerekli aletler
PY	Инструменты, необходимые для монтажа
中文	安装所需工具

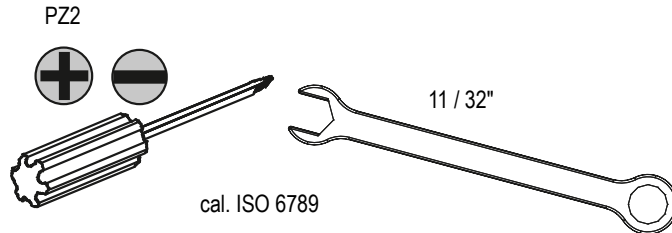

DE	Lieferumfang
EN	Quantity of delivery
FR	Composition de la fourniture
ES	Alcance del suministro
IT	Configurazione di fornitura
PT	Escopo de fornecimento
TR	Teslimat hacmi
PY	Комплект поставки
中文	供货范围

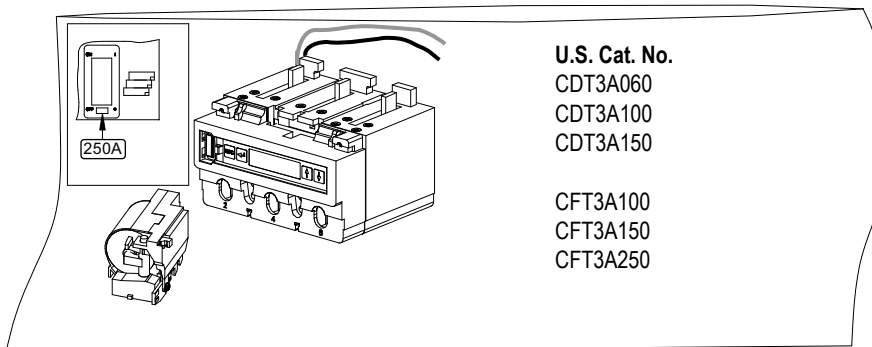
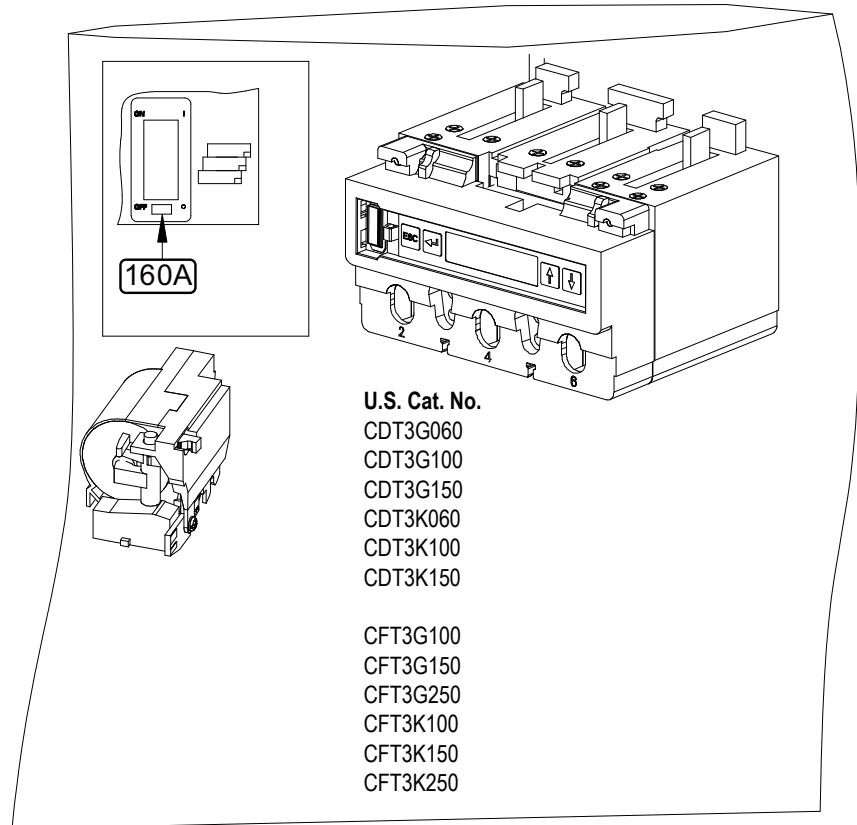

**⚠ DANGER****Hazardous voltage.****Will cause death or serious injury.**

Turn off and lock out all power supplying this device before working on this device.

**⚠ PELIGRO****Tensión peligrosa.****Puede causar la muerte o lesiones graves.**

Desconectar la alimentación eléctrica antes de trabajar en el equipo.

**⚠ DANGER****Tension électrique.****Danger de mort ou risque de blessures graves.**

Mettre hors tension avant d'intervenir sur l'appareil.

DE	Weiteres Zubehör
EN	Additional accessories
FR	Accessoires supplémentaires
ES	Otros accesorios
IT	Ulteriori accessori
PT	Acessório adicional
TR	Başka parçala
PY	Дополнительные приборы
中文	其他配件

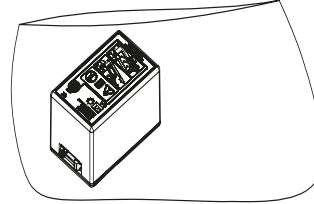

EPSP18V  
3VL90008AP01  
OR  
ELTPHB  
3VL9000-8AK01



2 x 8 - 32 x 3.38"  
MSKF2 -  
(2 + 3 Pole / Polos)  
3VL93000-6SB21

2x 19 lb.in.  
[2.2 Nm]

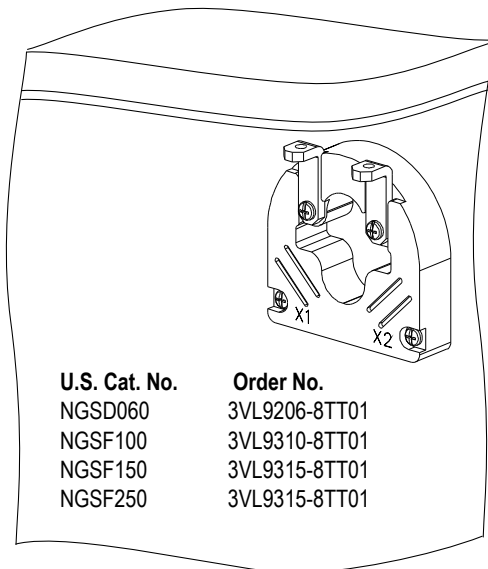
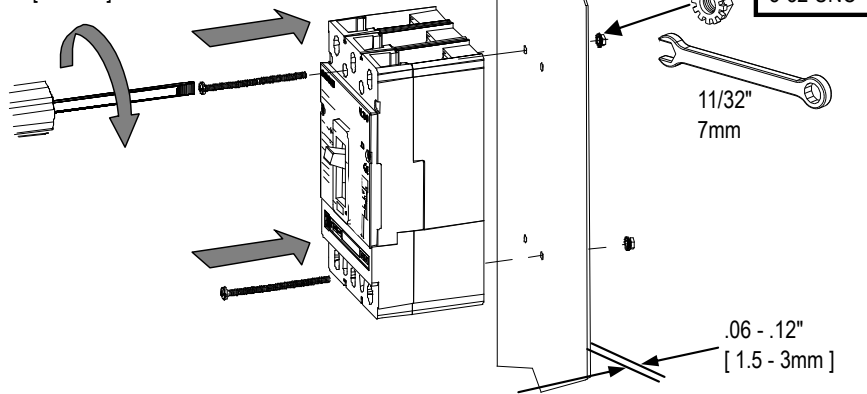

U.S. Cat. No.	Order No.
NGSD060	3VL9206-8TT01
NGSF100	3VL9310-8TT01
NGSF150	3VL9315-8TT01
NGSF250	3VL9315-8TT01

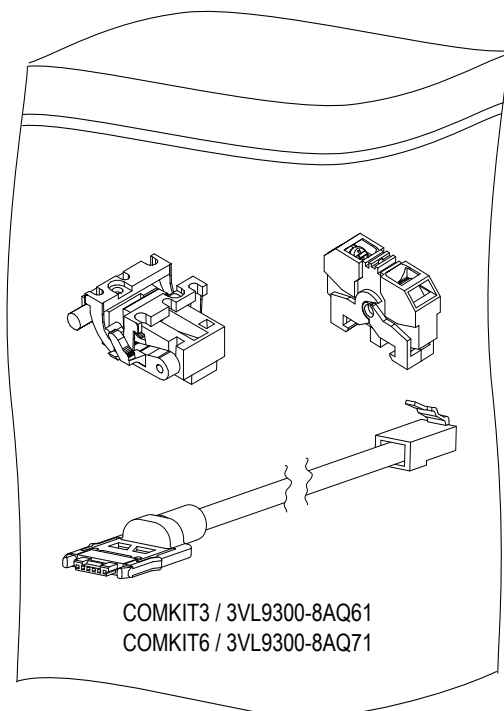

DE	Montage	ES	Montaje	TR	Montaj
EN	Assembly	IT	Montaggio	PY	Монтаж
FR	Montage	PT	Montagem	中文	安装

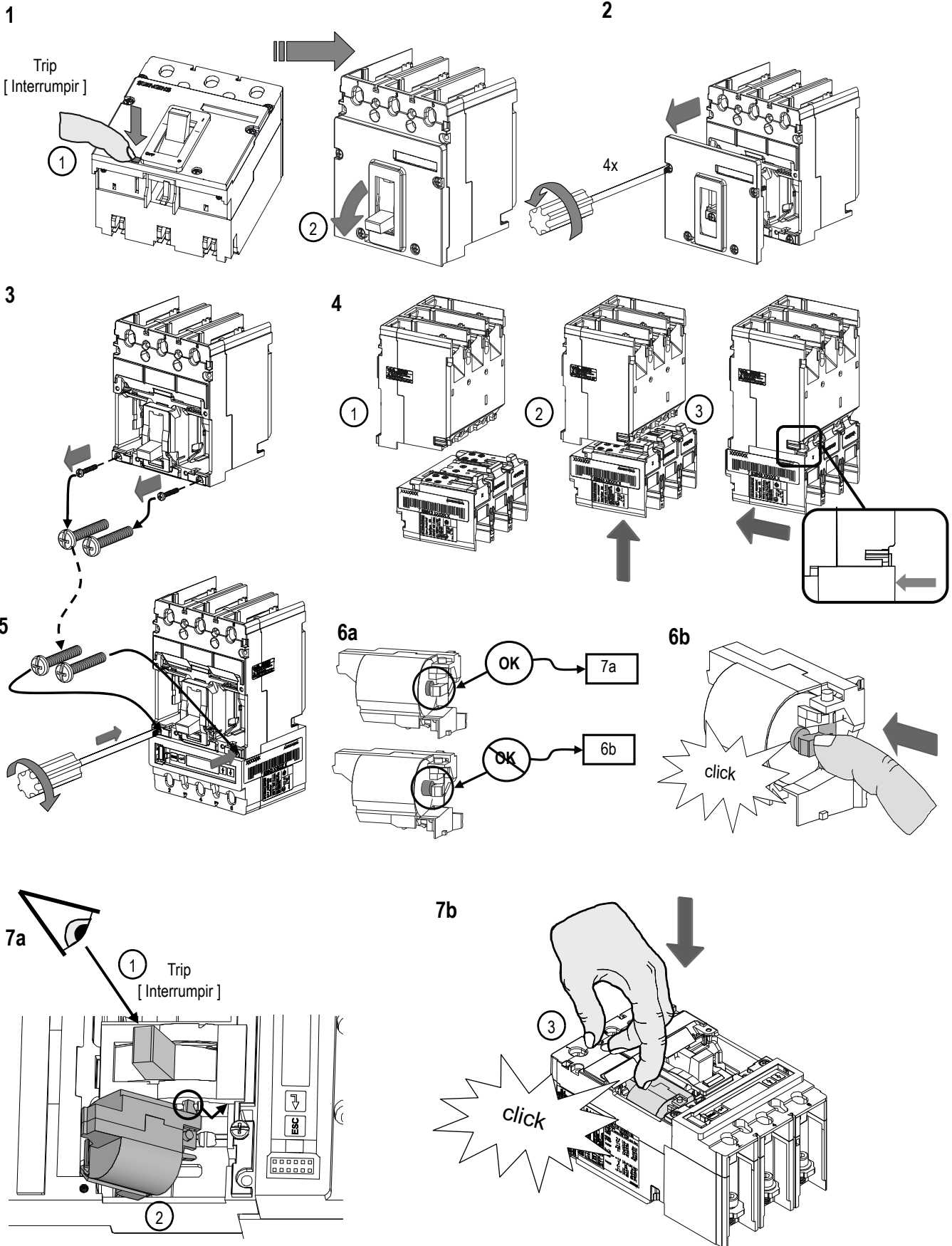

**⚠ DANGER****Hazardous voltage.****Will cause death or serious injury.**

Turn off and lock out all power supplying this device before working on this device.

**⚠ PELIGRO****Tensión peligrosa.****Puede causar la muerte o lesiones graves.**

Desconectar la alimentación eléctrica antes de trabajar en el equipo.

**⚠ DANGER****Tension électrique.****Danger de mort ou risque de blessures graves.**

Mettre hors tension avant d'intervenir sur l'appareil.

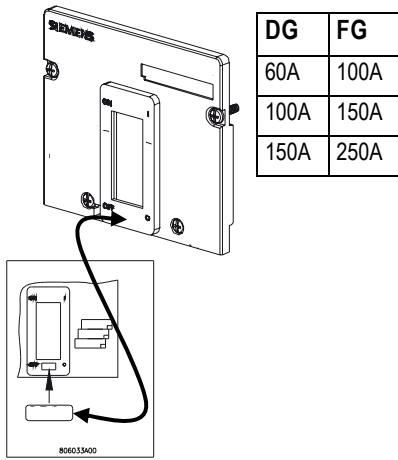
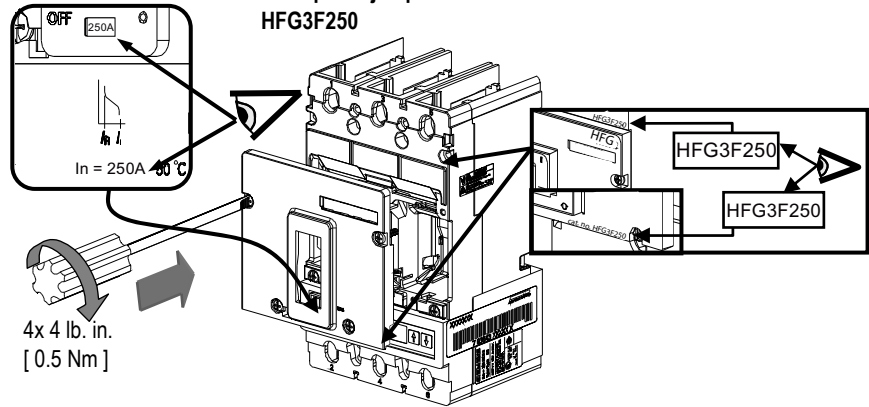
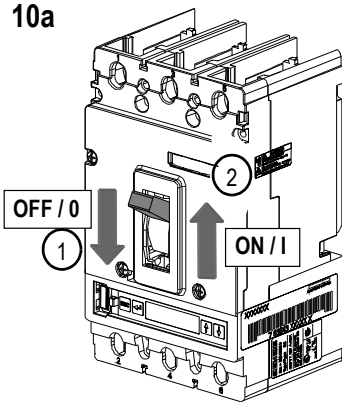
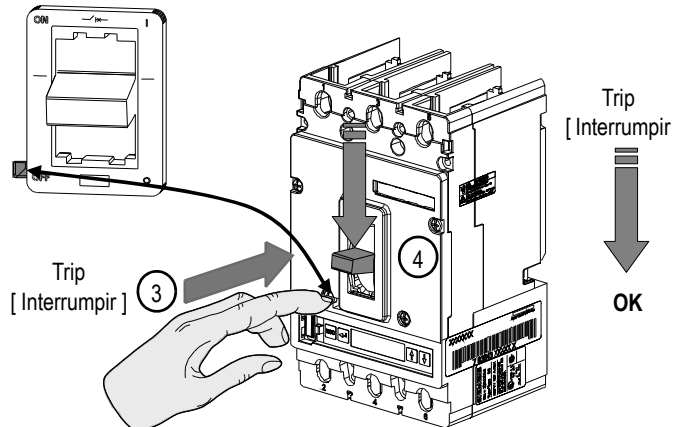
**8****Example / Ejemplo: 250A****9****Example / Ejemplo: HFG3F250****10a****10b**

TRIPPED

**11a**

TRIPPED

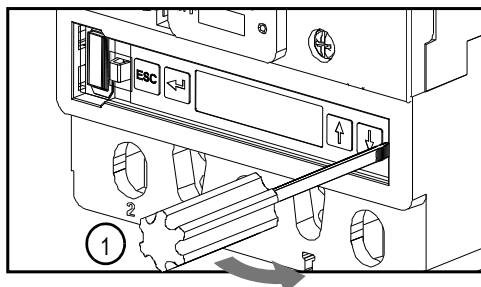
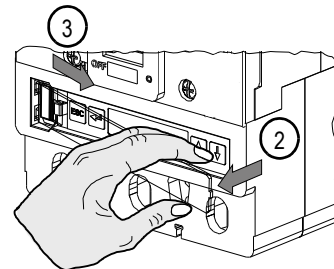
<http://www.siemens.com/lowvoltage/technical-support>**11a****11b**

12

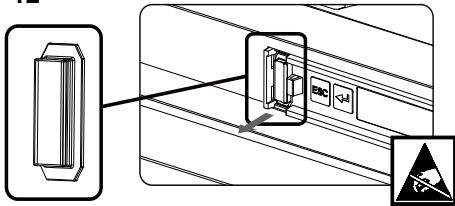

DE	<b>Achtung</b>	Vor Abnahme der Steckerabdeckung Leistungsschalter auf "OFF" schalten
EN	<b>Caution</b>	Place circuit breaker in "OFF" position before removing the plug cover
FR	<b>Attention</b>	Avant de retirer le cache du connecteur, positionner le disjoncteur sur "OFF"
ES	<b>Atención</b>	Ponga el interruptor automático en posición "OFF" antes de retirar la tapa del conector hembra
IT	<b>Attenzione</b>	Prima di rimuovere la copertura del connettore, portare l'interruttore automatico su "OFF"
PT	<b>Atenção</b>	Antes de retirar a cobertura do conector, mudar o disjuntor para "OFF".
TR	<b>Dikkat</b>	Fiş kapağını çıkarmadan önce güç şalterini "KAPALI" pozisyonuna getiriniz.
PY	<b>Внимание</b>	Перед снятием штекерной крышки установить силовой выключатель в положение "OFF" ("ВЫКЛ")
中文	<b>注意</b>	在取下插头罩盖之前先要把断路器调到 "OFF" 位置

13

Test:  
[ Prueba: ]

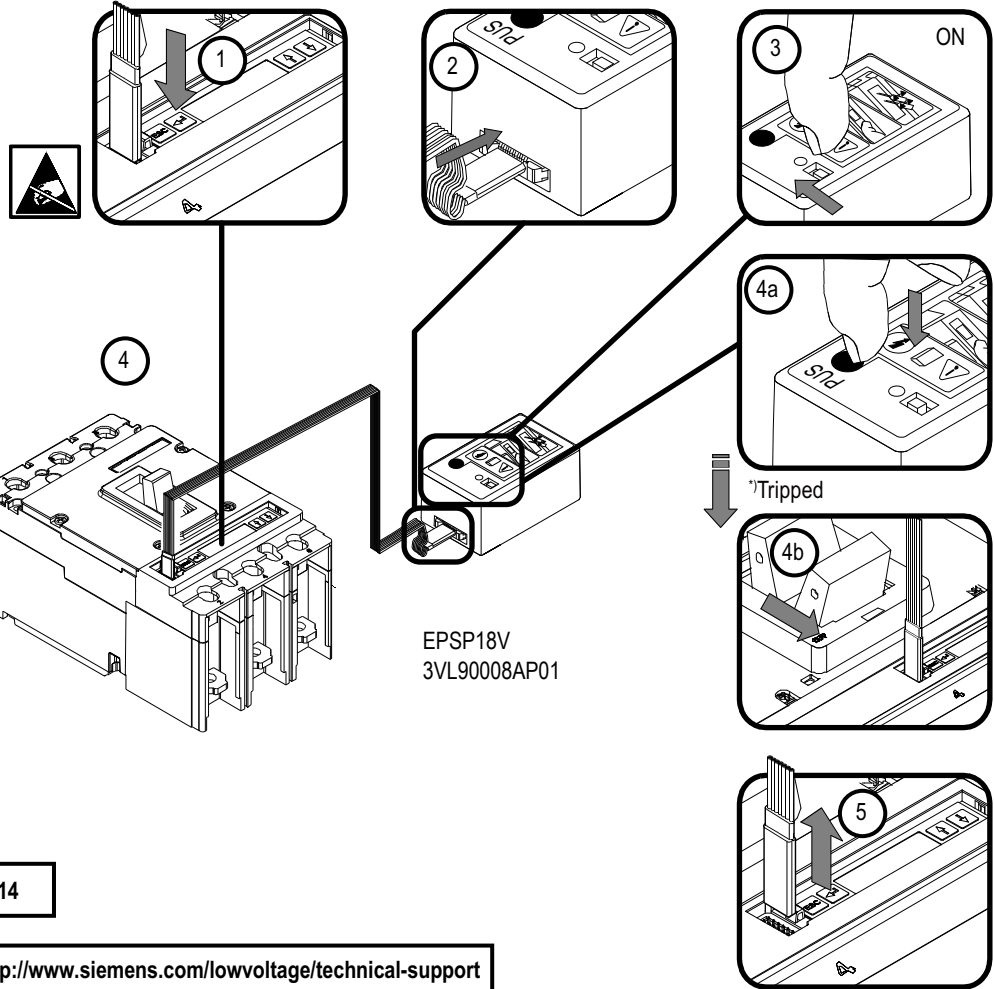

EPSP18V  
3VL90008AP01

\*)

DE	Ausgelöst
EN	Tripped
FR	Déclenché
ES	Disparado
IT	Sganciato
PT	Disparado
TR	Çözülmüş durum
PY	Разомкнуто
中文	断开



14

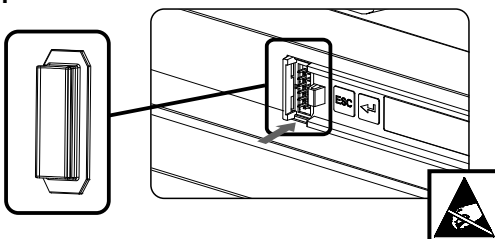

DE	<b>Achtung</b>	Vor dem Wiedereinschalten die Steckerabdeckung montieren
EN	<b>Caution</b>	Replace the plug cover before switching back on
FR	<b>Attention</b>	Avant de remettre sous tension, monter l'obturateur du connecteur
ES	<b>Atención</b>	Colocar la tapa del conector hembra antes de poner el interruptor en posición "ON"
IT	<b>Attenzione</b>	Prima della riattivazione montare la copertura del connettore
PT	<b>Atenção</b>	Antes de ligar novamente, montar a cobertura de conectores.
TR	<b>Dikkat</b>	Tekrar çalıştırmadan önce fiş kapağını monte ediniz.
PY	<b>Внимание</b>	Перед повторным включением установить штекерную крышку.
中文	<b>注意</b>	在重新接通电源前，要先安装插头罩盖。

<b>⚠ DANGER</b>	<b>⚠ PELIGRO</b>	<b>⚠ DANGER</b>
 <b>Hazardous voltage.</b> <b>Will cause death or serious injury.</b> Turn off and lock out all power supplying this device before working on this device.	<b>Tensión peligrosa.</b> <b>Puede causar la muerte o lesiones graves.</b> Desconectar la alimentación eléctrica antes de trabajar en el equipo.	<b>Tension électrique.</b> <b>Danger de mort ou risque de blessures graves.</b> Mettre hors tension avant d'intervenir sur l'appareil.

15

3ZW1012-OVL02-2AA0

16a

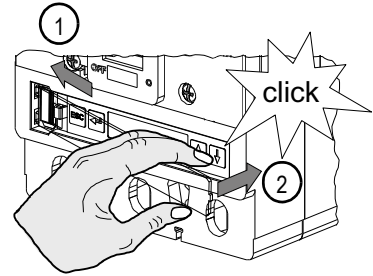
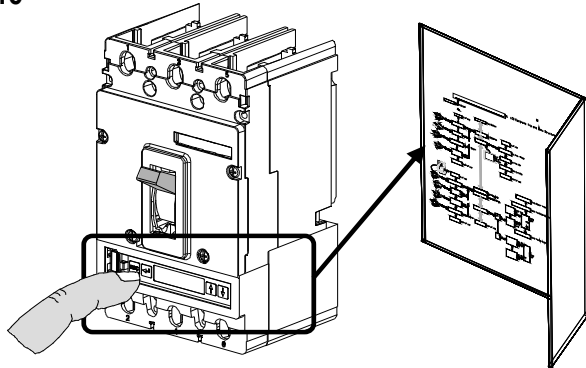



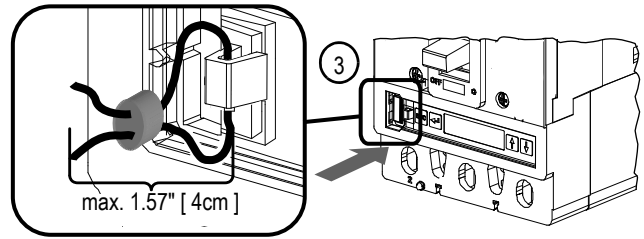



16b Option:  
Opción:



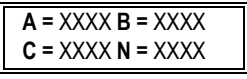
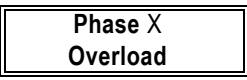

### Operation States [ Estado operación ]

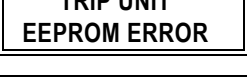
Definitions / Definiciones	
$I_n$	Rated Current / Intensidad asignada
$I_r$	Continuous Amps / Amperios continuo
$t_r$	Long Time Delay / Retardo largo
$I_{sd}$	Short Time Pickup / Tiempo corto inicio
$t_{sd}$	Short Time Delay / Retardo corto
	$I_i$ Instantaneous Pickup / Instantánea inicio
	$I_g$ Ground Fault Pickup / Inicio de falla a tierra
	$t_g$ Ground Fault Delay / Retardo de falla a tierra

LCD Display [ Pantalla LCD ]	System Status [ Estado de sistema ]	Operational State [ Estado de operación ]
	$< 25\% \times I_n$	OK
	$> 25\% \times I_n$	Not OK Contact Technical Support [ Lamar a Soporte Técnico ] <a href="http://www.siemens.com/lowvoltage/technical-support">http://www.siemens.com/lowvoltage/technical-support</a>
	$\geq 25\% \times I_n$ $< 105\% \times I_r$	OK
	$\geq 25\% \times I_n$ $> 105\% \times I_r$	OK
	$> 25\% \times I_n$ Wrong COM2x release connected; Connect "COM2x Release 2" (or newer)	May Not Be Operated, Last Selected Settings
	$> 25\% \times I_n$	*Minimum Settings [ * Ajuste de Minimo ] Contact Technical Support [ Lamar a Soporte Técnico ] <a href="http://www.siemens.com/lowvoltage/technical-support">http://www.siemens.com/lowvoltage/technical-support</a>
	$> 25\% \times I_n$	Not OK Contact Technical Support [ Lamar a Soporte Técnico ] <a href="http://www.siemens.com/lowvoltage/technical-support">http://www.siemens.com/lowvoltage/technical-support</a>
	$> 25\% \times I_n$	Not OK Contact Technical Support [ Lamar a Soporte Técnico ] <a href="http://www.siemens.com/lowvoltage/technical-support">http://www.siemens.com/lowvoltage/technical-support</a>

\* In event of damage to the device, Electronic Trip Units are equipped with a Minimum Setting feature. All settings override to the lowest possible value and the device must be replaced.

[\* En caso de daño al aparato, la unidad de disparo esta equipada con una característica de Ajuste de Minimo. Todos los ajuste se convierte al valor mas bajo posible y la unidad debe ser remplazada. ]

⚠ DANGER	⚠ PELIGRO	⚠ DANGER
 <b>Hazardous voltage.</b> Will cause death or serious injury.	<b>Tensión peligrosa.</b> Puede causar la muerte o lesiones graves.	<b>Tension électrique.</b> Danger de mort ou risque de blessures graves.
 Turn off and lock out all power supplying this device before working on this device.	Desconectar la alimentación eléctrica antes de trabajar en el equipo.	Mettre hors tension avant d'intervenir sur l'appareil.

## ETU Removal Instructions

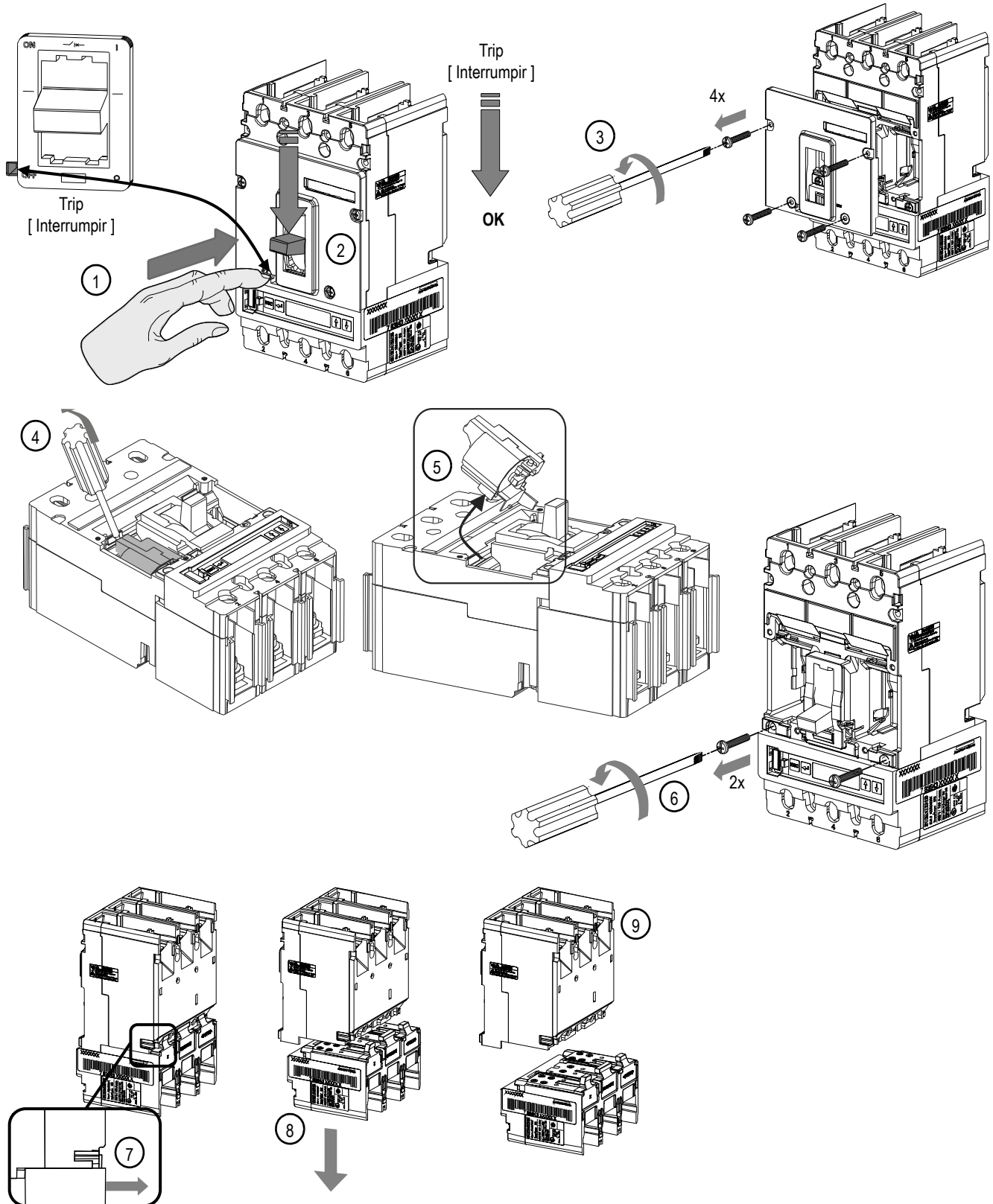

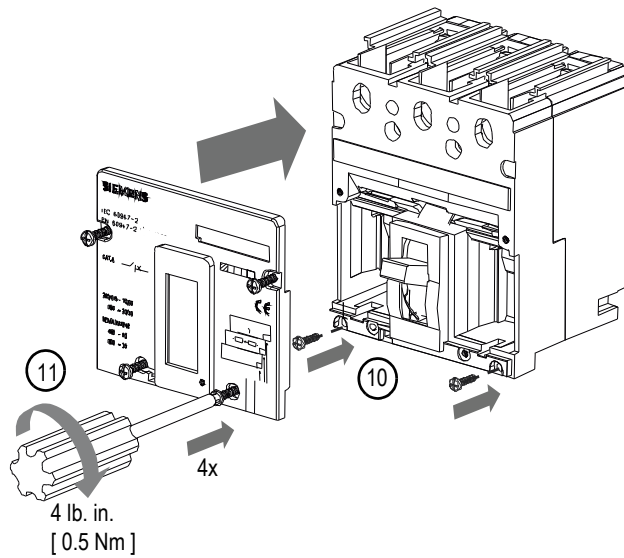

DE	Weitere Informationen finden Sie im 3VL-Handbuch im Internet unter: <a href="http://www.siemens.com/lowvoltage/manuals">www.siemens.com/lowvoltage/manuals</a> <a href="http://www.usa.siemens.com/powerdistribution">www.usa.siemens.com/powerdistribution</a> (nur in Deutsch und Englisch)
EN	Further information can be found in the 3VL manual on the internet at <a href="http://www.siemens.com/lowvoltage/manuals">www.siemens.com/lowvoltage/manuals</a> <a href="http://www.usa.siemens.com/powerdistribution">www.usa.siemens.com/powerdistribution</a> (only in German and English)
FR	Vous trouverez des informations supplémentaires dans le manuel 3VL sur le site Internet <a href="http://www.siemens.com/lowvoltage/manuals">www.siemens.com/lowvoltage/manuals</a> <a href="http://www.usa.siemens.com/powerdistribution">www.usa.siemens.com/powerdistribution</a> (seulement en allemand et en anglais)
ES	Para más información, consulte el manual 3VL que está disponible en nuestra página web <a href="http://www.siemens.com/lowvoltage/manuals">www.siemens.com/lowvoltage/manuals</a> <a href="http://www.usa.siemens.com/powerdistribution">www.usa.siemens.com/powerdistribution</a> (sólo en alemán e inglés)
IT	Ulteriori informazioni sono disponibili in Internet nel manuale 3VL su <a href="http://www.siemens.com/lowvoltage/manuals">www.siemens.com/lowvoltage/manuals</a> <a href="http://www.usa.siemens.com/powerdistribution">www.usa.siemens.com/powerdistribution</a> (solo in tedesco e in inglese)
PT	Mais informações encontram-se no manual 3VL na Internet, sob <a href="http://www.siemens.com/lowvoltage/manuals">www.siemens.com/lowvoltage/manuals</a> <a href="http://www.usa.siemens.com/powerdistribution">www.usa.siemens.com/powerdistribution</a> (somente em alemão e em inglês)
TR	Ayrıntılı bilgiyi aşağıdaki internet adresindeki 3VL kullanma kılavuzundan edinebilirsiniz: <a href="http://www.siemens.com/lowvoltage/manuals">www.siemens.com/lowvoltage/manuals</a> <a href="http://www.usa.siemens.com/powerdistribution">www.usa.siemens.com/powerdistribution</a> (sadece Almanca ve İngilizce olarak)
PY	Дальнейшую информацию Вы сможете найти в инструкции по эксплуатации 3VL в интернете по адресу: <a href="http://www.siemens.com/lowvoltage/manuals">www.siemens.com/lowvoltage/manuals</a> <a href="http://www.usa.siemens.com/powerdistribution">www.usa.siemens.com/powerdistribution</a> (только на немецком и английском языке)
中文	其他相关信息参见 3VL 使用手册, 请登陆互联网: <a href="http://www.siemens.com/lowvoltage/manuals">www.siemens.com/lowvoltage/manuals</a> (德、英文)

