



CENTERLINE 2100 Motor Control Centers

Bulletin 2100



Allen-Bradley

by ROCKWELL AUTOMATION

Selection Guide

What's Inside

Topic	Page
What's New	2
CENTERLINE 2100 Motor Control Centers	3
Step 1: Review MCC Technical Specifications and Certifications	7
Step 2: Select Network Technology	10
Step 3: Select Structure	16
Step 4: Select Power Bus and Ground Bus Systems	25
Step 5: Select Unit Design	27
Step 6: Select Unit Types	30

What's New

ArcShield™ Device Limited expanded to include up to 600V and 3000 A bus ratings.

ArcShield 100 ms arc duration and device limited with bus ratings of 1600 A and above ratings.

Arc resistant baffles for 480V device limited with bus rating up to 3000A or for 600V device limited with bus ratings up to and including 1200 A.

The CENTERLINE™ 2100 MCC combines rugged durability and premium quality, meeting UL and NEMA standards. CENTERLINE 2100 MCCs integrate control and power in one package with a variety of motor control options built per your local specifications.

High Performance Motor Control Centers

This industry-leading motor control center has delivered the safety, performance, and reliability you need for over 50 years.

- Designs are certified to UL 845 and meet NEMA standards
- Helps reduce arc flash incidents with ArcShield technology
- Insulated horizontal bus option helps improve personnel safety by preventing arc propagation. It is a corrosion-resistant, ready-to-install insulating wrap that you can assemble quickly.
- Space saving designs maximize section use reducing your MCC footprint
- Offers a variety of intelligent motor control options such as:
 - Across-the-line starters with E300™ Electronic Overload Relays
 - Soft starters
 - Variable speed drives
- SecureConnect™ technology helps provide a safer work environment with the ability to disconnect power from the vertical power bus in an individual unit with the door closed
- High short-circuit current ratings in type-tested enclosures
- Factory tested for faster and more dependable start-up
- CENTERLINE 2100 MCCs with IntelliCENTER® technology have built-in networking and preconfigured software to:
 - Enhance performance through system-wide communications
 - Share diagnostic information for predictive maintenance
 - Initiate warnings before potential faults occur
- CENTERLINE 2100 MCCs are designed to:
 - Allow for backward compatibility
 - Provide bus bracing for uniform support
 - Fully isolate the enclosure and provide a solid grounding system
 - Maximize section use with space-saving designs
 - Improve heat dissipation

Safety

CENTERLINE MCCs help deliver safety, performance and reliability while meeting various standards. We certify the CENTERLINE 2100 MCCs to UL 845 – while helping drive alignment with common standards, like NFPA70E and CSA-Z465. We test our MCCs to meet the requirements of IEEE and Seismic specifications.

CENTERLINE MCCs offer safety features that allow you to design a CENTERLINE 2100 MCC to meet the needs of your electrical safety program. The following safety features can help protect personnel and eliminate unplanned outages and downtime:

- Plug-in replacement units allow maintenance to be performed away from energized controls.
- Intelligent motor control devices help warn of an impending failure before it occurs.
- Locking and Interlocking features allow for easier use of your company's lockout/tagout safety procedures.
- Through-the-door DeviceNet and Ethernet ports give you access to the network without opening the unit door.
- Infrared windows and through-the-door viewing window lets you inspect the unit without opening doors, improving personnel safety.

SecureConnect Technology

The SecureConnect technology option for CENTERLINE 2100 MCCs helps reduce exposure to electrical hazards by allowing a unit to be disconnected from the vertical power bus with the enclosure door closed. Its 'snap action' retract mechanism of the stabs helps to reduce exposure to electrical shock and arc-flash events by quickly disconnecting the stabs and isolating them behind two sets of shutters. SecureConnect Technology includes a multi-point validation system that is both electrical and mechanical. This system can be used to validate that the stabs have been retracted completely into the housing and that the stab shutters have been closed. SecureConnect technology has been extended to high current applications for Size 4 units with currents up to 225 A and is part of our standard delivery program.



SecureConnect unit with shutters open is 'engaged with the busbar position'

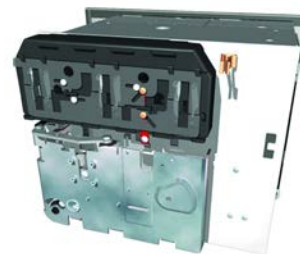

Shutters closed is 'disengaged' so the unit can be removed

IntelliCENTER Technology

IntelliCENTER technology enhances the intelligence of the CENTERLINE 2100 MCC by using built-in networking to capture information used for predictive maintenance, process monitoring, and advanced diagnostics. IntelliCENTER technology can save you time because each MCC is pre-wired, and the network is pre-programmed and validated at the factory. Network devices are preconfigured with node addresses and communication rates, ready to communicate so you can configure device parameters (such as acceleration time and full load amps) via the network.

IntelliCENTER Software

The addition of IntelliCENTER software provides the ultimate window into your MCC. The preconfigured software provides maintenance personnel with easy access to real-time critical CENTERLINE MCC configured information and process data for troubleshooting. The configurable graphic views provide system status at a glance and help keep facilities running with electronic documentation, remote diagnostics, and predictive maintenance. IntelliCENTER software significantly reduces HMI programming time and PLC development time with automatic tag generation and even complete network configuration before the MCC is powered up.

IntelliCENTER System Configuration (ISC)

All IntelliCENTER MCCs include IntelliCENTER System Configuration from the factory. Firmware normalization ensures that all intelligent devices ship with the same customer-specified firmware revision. Custom parameter programming is available to provide pre-configured device settings to simplify configuration and shorten commissioning time.

Integration Assistant

With IntelliCENTER Integration Assistant, you can seamlessly integrate your IntelliCENTER MCCs into Studio 5000® programming software. This feature helps reduce programming time by automatically adding the CENTERLINE MCC devices to the Studio 5000 I/O tree.

IntelliCENTER Energy

IntelliCENTER Energy offers a preconfigured setup of FactoryTalk® EnergyMetrix™ software for intelligent motor control devices in the MCC, including variable speed drives, overload relays, and smart motor controllers (SMC™). With IntelliCENTER Energy, you can view energy consumption at the device level directly from IntelliCENTER software, making it easier to monitor and manage energy usage in the industrial facility.

For more information about IntelliCENTER software features, see [page 14](#).



ArcShield Technology

You can't predict when an arc blast will occur, which makes arc resistant designs important.

The CENTERLINE 2100 MCC with ArcShield has been tested in accordance with the IEEE C37.20.7 standard for Type 2 accessibility. Type 2 accessibility allows your personnel to be protected on all sides of the enclosure in the event of an arcing fault.

A recessed horizontal bus and labyrinth vertical bus helps to prevent arcs from spreading between phases. True unit and wireway isolation and special arc-containment door latches help deliver an extra level of protection against internal electrical arcing faults.

Patented arc resistant baffles for the CENTERLINE 2100 MCC with ArcShield accommodate the need for venting while maintain Type 2 accessibility.



Select a CENTERLINE 2100 MCC

Step 1: Review MCC Technical Specifications

Determine what certifications, ratings, and other technical specifications are needed for your application. Step 1 starts on [page 7](#).

Step 2: Select Network Technology

Choose the type of networking technology, diagnostic and HMI software tools and additional arc flash safety features. Step 2 starts on [page 10](#).

Step 3: Select Structure

Choose the NEMA/UL enclosure, section height, depth, wireway size, and type of shutters. Step 3 starts on [page 16](#).

Step 4: Select Power Systems

Choose electrical system, incoming power, power and ground bus, horizontal and vertical power bus capacity, bus withstand and short circuit current rating. Step 4 starts on [page 25](#).

Step 5: Select Unit Designs

Choose type of door latches and color and type of nameplates. Step 5 starts on [page 27](#).

Step 6: Select Unit Types

Choose the type of units and unit specific options from lugs and breakers, non-motor loads, starters, space-saving NEMA starters, metering units, soft starters, variable frequency drive, PLCs, and pilot devices. Step 6 starts on [page 30](#).

Last Step: Consult the Program Guide and Complete the CENTERLINE 2100 MCC Specification Checklist

The CENTERLINE 2100 Motor Control Centers Program Guide, publication [2100-CA004](#), provides a guideline for configuration of a motor control center by providing specifications for each unit type.

Complete each corresponding part of the CENTERLINE 2100 MCC Specification Checklist, publication [2100-SR003](#), as you work through each step. A completed checklist can help your local sales office better understand your needs.

Step 1: Review MCC Technical Specifications and Certifications

UL/cUL/CSA Marking

CENTERLINE 2100 Motor Control Centers are listed by Underwriters Laboratories, Inc. (file number E49289) as complying with Standard Safety UL 845 (UL) and either listed by Underwriters Laboratories, Inc. or certified by Canadian Standards Association (CSA) as complying with standard C22-2, No. 254-05 (cUL or CSA). CENTERLINE 2100 MCCs also meet the requirements in Mexican standard for MCCs, NMXJ-353-ANCE-2006. Therefore, the MCC product, sections, and units carry the respective marking unless otherwise indicated in the footnotes on the various pages in this publication.

ISO 9001 Certification

The facilities that develop and manufacture CENTERLINE 2100 MCCs are located in Milwaukee and Richland Center, Wisconsin, Tecate, Mexico and Guadalupe, Mexico. All facilities have been certified to be in conformance to the requirements of Quality Management System ISO 9001. These facilities presently are certified by Det Norske Veritas to ISO 9001:2015, Certificate number CERT-09379-2004-AQ-USA-ANAB, effective May 16, 2025.

For more information about product certification, visit rok.auto/certifications.

American Bureau of Shipping (ABS)

CENTERLINE 2100 MCCs have fulfilled the requirements and are approved by the American Bureau of Shipping (certificate SB55875-X). CENTERLINE 2100 MCCs do meet ABS shipping requirements. Contact your local Rockwell Automation sales office for availability of ABS maritime shipping.

NEMA Class

NEMA—National Electrical Manufacturers Association.

The following is a description of Class I, as paraphrased from NEMA standard ICS 18-2001: Class I motor control centers shall consist of mechanical groupings of combination motor control units, feeder tap units, other units and electrical devices arranged in a convenient assembly. They include connections from the common horizontal power bus to the units. They do not include interwiring or interlocking between units or to remotely mounted devices, nor do they include control system engineering. Only diagrams of the individual units are supplied.

NEMA Class II interwiring offers the addition of interlocking and wiring between units as specifically described in overall control system diagrams supplied by the purchaser. Contact your local Rockwell Automation sales office for availability.

NEMA Type

Class I motor control centers can be provided in NEMA Type A or B construction:

- Type A—User's power and control connections are made directly to the device within the unit.
- Type B—Terminal blocks are supplied for user's control termination within unit insert. On NEMA size 1 through 3 starter units and 30...100 A contactors units, terminal blocks are also supplied for user's load terminations (NEMA Type BT). NEMA Space Saving units do not include power terminal blocks (NEMA Type BD).

NEMA/UL and IEC Enclosure Comparison

The following table is a comparison of Allen-Bradley CENTERLINE 2100 MCC NEMA/UL enclosure type numbers to IEC Standard 60529, Classification of Degrees of Protection Provided by Enclosures. The comparison is based on data from tests conducted on the CENTERLINE 2100 MCC enclosures and the NEMA/UL enclosure type test requirements, which meet or exceed the IEC enclosure classification designation test requirements.

NEMA/UL Type 1 vented (with or without gasketed doors)	IP20
NEMA/UL Type 1 vented with filters (with or without gasketed doors)	IP30
NEMA/UL Type 1 non-vented (without gasketed doors)	IP40
NEMA/UL Type 1 with drip hood = NEMA/UL Type 2 (with or without gasketed doors)	IP41
NEMA/UL Type 3R	IP44
NEMA/UL Type 12 without bottom plates	IP53
NEMA/UL Type 12 with bottom plates	IP54
NEMA/UL Type 4	IP65

NEMA/UL Enclosure Type Descriptions

- NEMA/UL Type 1 - Type 1 units and sections are intended for indoor use, primarily to provide a degree of protection against contact with the enclosed equipment in locations where unusual service conditions do not exist. The enclosures are designed to meet the rod entry and rust resistance design tests. The enclosure is sheet steel, treated to resist corrosion.
- NEMA/UL Type 1 with gasketed doors (sometimes referred to as 1G) - Type 1 with gasketed unit doors are completely gasketed around the perimeter of the unit doors. All gasketing is closed cell neoprene.
- NEMA/UL Type 12(1) - Type 12 enclosures are intended for indoor use, primarily to provide a degree of protection against dust, falling dirt and non-corrosive dripping liquids. They are designed to meet drip, dust and rust resistance tests. They are not intended to provide protection against conditions such as internal condensation.
- NEMA/UL Type 3R - Non-walk-in front mounted only. Door-within-a-door construction. Type 3R units and sections are intended for outdoor use, primarily to provide a degree of protection against falling rain and to avoid damage from the formation of ice on the enclosure. They are designed to meet rod entry, rain, external icing and rust resistance design tests. They are not intended to provide protection against conditions such as dust, internal condensation or internal icing.
- NEMA/UL Type 4 - Non-walk-in front mounted only. Door-within-a-door construction. Type 4 units and sections are designed for indoor and outdoor use, primarily to provide protection against windblown dust and rain, splashing water and hose-directed water. They are also designed to remain undamaged by the formation of ice on the enclosure. They are designed to meet hosedown, external icing, and rod entry design tests. The enclosures are not designed to protect against internal condensation, rust resistance, or internal icing.

Seismic Applications

CENTERLINE 2100 MCCs meet the requirements for Uniform Building Code (UBC) Zone 4 seismic applications and comply with the following criteria:

- 2012, 2015, 2018, and 2021 International Building Code (IBC)
- 2013, 2016, and 2019 California Building Code (CBC)
- British Columbia Building Code 2018 (2018 BCBC)

Actual CENTERLINE 2100 Motor Control Center (MCC) samples have been seismically qualified by dynamic (triaxial multi-frequency testing) seismic tests per IEEE 344 Seismic Test Standards. The results of this MCC seismic testing demonstrated compliance with the 100% g level of Uniform Building Code 1997 (UBC) Zone 4 (the maximum UBC Zone) and 100% g level of the International Building Code 2006 (IBC), that is, the MCC structure, the MCC units, the MCC components or electrical functions were not compromised when subjected to a UBC Zone 4 earthquake or the IBC seismic event. Per the IEEE 344 Standard, the equipment was under power and operated before, during and after the seismic tests.

To obtain a UBC or IBC seismic with standability, each individual CENTERLINE 2100 MCC line-up must be mounted on an adequate seismic foundation and installed per the seismic anchoring requirements as indicated in publication [2100-IN012](#), CENTERLINE 2100 Motor Control Centers User Manual.

IMPORTANT Variable frequency drive units using 'rollout' drive configurations are not seismically certified.

Motor Applications

Engineering evaluations are available for the protective device (circuit breaker or fuse) selection, sizing and setting range based on the protection rules/requirements and motor criteria as stipulated in NEC, NEMA and UL standards (for example, motor full load currents [FLCs], X/R ratios, lock rotor currents, and nominal utilization voltages). Should the motor application have criteria that deviate from those stated in the aforementioned standards, higher FLC and/or motor inrush currents (greater than 1300% of the nominal FLC) can be experienced (for example, special motors, non-standard NEMA motors, energy efficient motors, Design E motors, and IEC Type N motors).

- This publication refers to standard NEMA/UL Type 12 design (that is, standard sheet steel). For stainless steel NEMA/UL Type 12 enclosures, contact your local Rockwell Automation sales office.

Specifications

CENTERLINE 2100 MCC Specifications

Standards	Certifications & Listings	NEMA ICS-18, UL845, CSA C22.2 No. 14 and EN 60439-1
Enclosure	NEMA/UL Type	1 (IP20, IP30, IP40) 1 with gasketing around perimeter of unit doors (IP20, IP30, IP40) 12 (IP54) 3R non walk-in (IP44) 4 non walk-in (IP65)
Bus Material and Plating	Horizontal Bus Rating	600 A; 800 A; 1200 A; 1600 A; 2000 A; 2500 A or 3200 A
	Horizontal Bus Withstand Rating	42 kA; 65 kA or 100 kA
	Horizontal Bus Material	Aluminum with Tin-plating; Copper with Tin-plating or Copper with Silver-plating
	Vertical Bus Rating	300 A (600 A effective) or 600 A (1200 A effective)
Unit Design	Vertical Bus Material	Copper with Tin-plating or Copper with Silver-plating (matches horizontal bus material)
	Unit Size	6.5 in. (165 mm) high x 14 in. (356 mm) wide = half space factor 13 in. (330 mm) high x 14 in. (356 mm) wide = one space factor Unit designs are in 0.5 space factor increments
	Maximum Space Factors per Section	6
Structural Surface Treatments	Exterior (NEMA/UL Type 1, 1G, 12)	ANSI 49 - Medium Light Gray
	Exterior (NEMA/UL Type 3R)	UV Resistant High Gloss White - Recognized by UL for outdoor use
	Exterior (NEMA/UL Type 4)	Unpainted Stainless Steel
	Interior	ANSI 49 - Medium Light Gray; High Visibility White Gloss (vertical wireways and unit back plates)
Environment	Storage Temperature	32...104 °F (0...40 °C) with up to 95% noncondensing humidity
	Operating (Ambient) Temperature	32...104 °F (0...40 °C) with up to 95% noncondensing humidity
	Altitude	6600 feet (2km)

Step 2: Select Network Technology

IntelliCENTER technology is available in either a EtherNet/IP™ or DeviceNet® network configuration. Both options protect media behind barriers, let you access ports via wireways, and support topologies that let you add or remove devices without shutting down the network.

Factory-configured and validated network media reduces your need to make device connections and set baud rates, node, or IP addresses.

Both Ethernet and DeviceNet networks are compatible with the intelligent motor control options available in CENTERLINE 2100 MCCs:

- Built-in Networking
 - Media protected behind barriers
 - Access ports in wireways
 - DeviceNet trunk and drop topology, and Ethernet hybrid linear/star topology allow for adding and removing devices without shutting down the network
- Intelligent Motor Controls
 - PowerFlex® drives
 - SMC™-3 and SMC Flex soft starters
 - E300 Electronic Overload Relays
- IntelliCENTER Software
 - Elevation View
 - Monitor View
 - Documentation View
 - Spreadsheet View
 - Integration Assistant
- Factory Configuration
 - Network media validation
 - Node configuration
 - Device communication check

IntelliCENTER technology improves the intelligence of your MCC by using built-in network to capture information used for predictive maintenance, process monitoring, and advanced diagnostics.

IntelliCENTER Technology with EtherNet/IP Network

EtherNet/IP enhances integration, helps reduce your MCC set-up time, and increases the network speed. With EtherNet/IP, you can quickly monitor, troubleshoot, and diagnose your MCC from anywhere. CENTERLINE MCCs provide robust motor control capabilities with access to the real-time data you need by using a network that communicates with your entire enterprise. Use of an EtherNet/IP network enables IntelliCENTER Integration Assistant that automatically configures and populates your I/O tree and network configuration.

The publication [2100-TD031](#) provides more information about the CENTERLINE 2100 MCC with IntelliCENTER technology using an EtherNet/IP network. The CENTERLINE Motor Control Centers EtherNet/IP IntelliCENTER Information Reference Manual, publication [MCC-RM001](#), describes the EtherNet/IP network as it relates to an IntelliCENTER motor control center.

System Performance

The EtherNet/IP network can accommodate a vast number of nodes. The EtherNet/IP network does not have a specific maximum number of nodes like other fieldbus networks. The limit is based on the number of connections the EtherNet/IP scanner can make. The number of connections used by each node varies by application. To estimate the number of connections your application would use, download [Integrated Architecture Builder](#) (IAB) software. Use IAB to layout and validate control systems. Download Integrated Architecture Builder from the Product Selection Toolbox executable file or the mobile app.

The EtherNet/IP network uses fiber or copper twisted-pair wiring. The maximum length of copper twisted-pair wiring is 100 m between devices. There is no cumulative length for the entire network. Fiber cable length varies by design of the cable. Inside the MCC, all cables are copper twisted-pair.

An EtherNet/IP system has the following capabilities:

- Automatic Device Configuration (ADC) automatically downloads the IP address, firmware, and device parameter settings to a newly replaced device without user interaction.
- Switch-level linear or switch-level ring topologies provide network flexibility for any sized operation.
- Heavy traffic performance.
- Add or subtract nodes on-the-fly.
- Advanced network configuration, security, and diagnostics are provided by layer-2 managed Ethernet switches.
- The EtherNet/IP system in the MCC is designed to operate at 100 Mbaud.

Devices and Cabling

A switch group is used to connect Stratix™ switches to intelligent devices within the MCC in a flexible and scalable manner. Switch groups can span up to nine vertical MCC sections and include up to 24 Ethernet/IP devices. Two options for mounting exist:

- Unit Mounted leverages higher port capacities, and it frees up the horizontal wireway for customer cabling.
- Horizontal Wireway Mounted maximizes available unit space for intelligent motor control devices.

Homerun Cabling reduces costs and simplifies network troubleshooting by providing a direct connection from the ethernet switch port to the intelligent device.

Vertical Wireway Ethernet Adapters provide connectivity from the intelligent device to the switchboard without needing to enter the unit. Units with devices that require 24V DC network power have a connection from the device, plugged into the power ports. Each EtherNet/IP port is independent, allowing any unit to be plugged in and removed without affecting adjacent units.

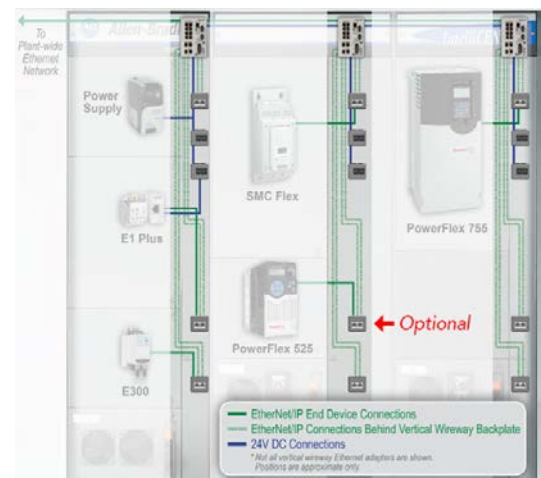

EtherNet/IP Network Components

Each unit can be provided with an Ethernet component.

- Starter units can be provided with E300 Overload Relays with embedded Ethernet.
- Variable frequency AC drives can be provided with embedded Ethernet or an EtherNet/IP communication module.
- Solid-state controllers can be provided with EtherNet/IP communication modules.

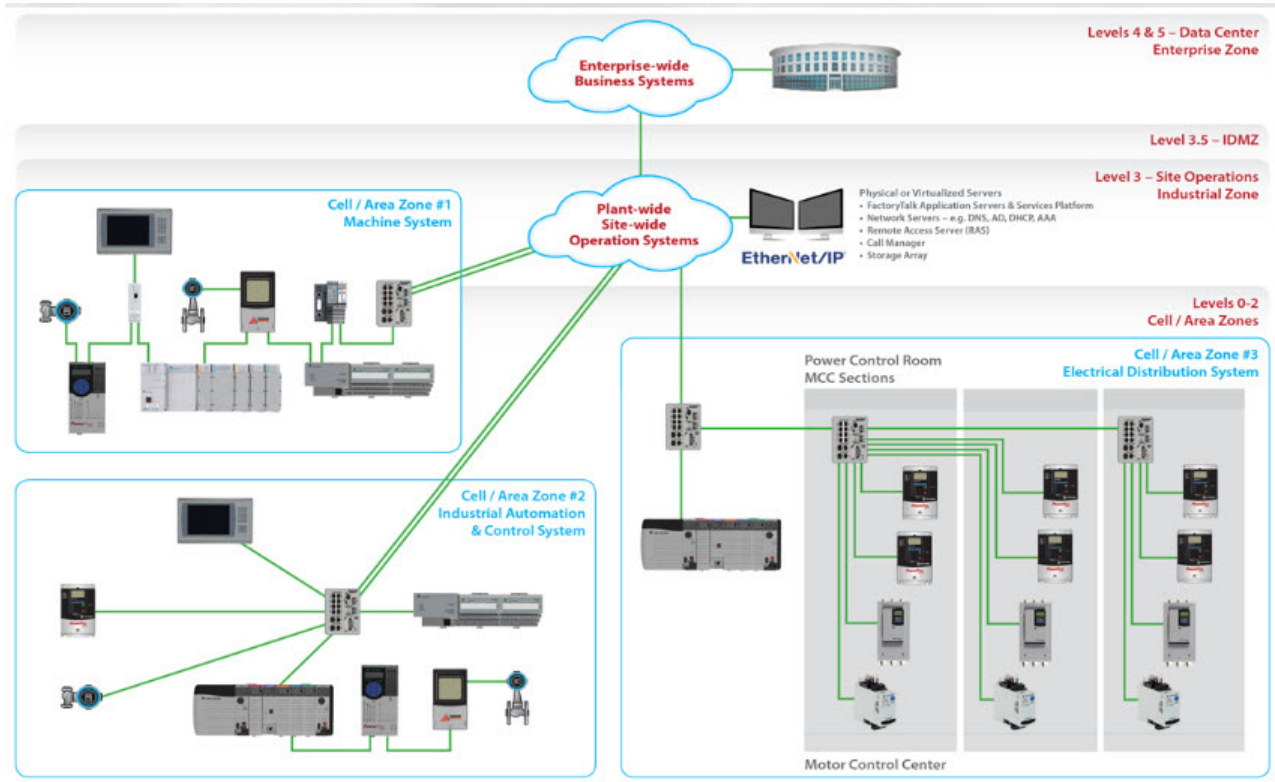

IntelliCENTER Technology with DeviceNet Network

The publication [2100-TD001](#) provides more information about the CENTERLINE 2100 MCC with IntelliCENTER technology using a DeviceNet network.

A DeviceNet network is a simple, open networking solution, allowing for real-time control, data exchange, configuration, and data connection at regular intervals or on demand.

The cost and performance of a DeviceNet network makes it a good fit for MCC applications. Over 300 vendors offer DeviceNet products with over a half million nodes installed worldwide.

System Performance

To achieve best performance, the DeviceNet system in the MCC is designed to operate at a 500 kbaud communication rate but engineered for a minimum communication rate of 250 kbaud. Therefore, the DeviceNet system in the MCC can communicate and perform under normal and adverse electrical environments (for example, contactor electrical operation, contactor jogging duty, and unit short circuit fault).

The DeviceNet system has the following capabilities:

- Automatic Device Replacement (ADR) which automatically downloads the parameter settings of a failed device to its replacement.
- On-line Scanlist Changes at Run, allows network modifications to be performed on a DeviceNet system that is running.
- By choosing the appropriate scan mode (Polled, Change of Stat (COS), Strobe and Cyclic) for different data, DeviceNet systems can achieve better throughput performance than networks with much higher communication rates.
- Allow the control system to access every parameter in the device, not just a few registers, by transmitting and receiving data via I/O explicit messaging.

Devices and Cabling

EtherNet/IP and ControlNet linking devices allow you to quickly connect your factory network to a CENTERLINE 2100 MCC with IntelliCENTER technology.

All trunk and drop DeviceNet cabling is ODVA certified Class 1, with 600V insulation and 8 A rating. The DeviceNet cabling system for IntelliCENTER technology has been extensively tested for noise immunity with network cables in close proximity to high current motor leads.

The DeviceNet trunk line is routed through the vertical wireway of the MCC. Trunk lines are routed behind barriers to isolate the cable from the unit space and wireways to help prevent accidental damage.

Up to six DeviceNet ports can be provided in the control and network wireway. Each DeviceNet component in an MCC unit is connected to the network through a port located in the wireway. Adding or removing units from the network does not interrupt the other units operating in the system.

DeviceNet Network Components

Each unit can be provided with a DeviceNet component.

- SMC smart motor controllers with an DeviceNet Communication Module.
- Starter units can be provided with an E300 Electronic Overload Relay with embedded DeviceNet network.
- Variable frequency AC drives can be provided with a DeviceNet communication module.
- Solid-state controllers can be provided with DeviceNet communication modules.

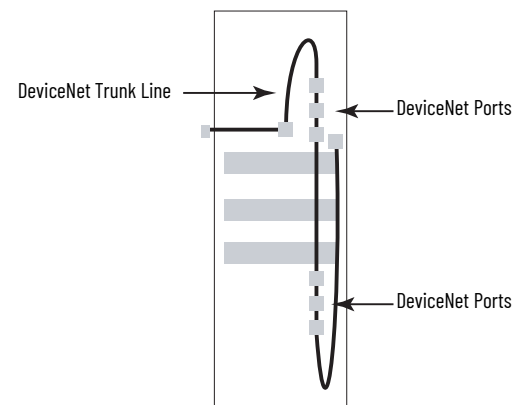

Inside look at DeviceNet cable routing in one CENTERLINE 2100 MCC section.

IntelliCENTER Software

The CENTERLINE 2100 MCC is available with pre-configured IntelliCENTER software. IntelliCENTER software is an intuitive software package that is customized to your MCC. This software package includes several preconfigured views for easy access to important information and is capable of viewing multiple MCC line-ups. IntelliCENTER software can be installed and operated on EtherNet/IP or DeviceNet. The IntelliCENTER software is capable of functioning as a stand alone software package or as an ActiveX control in a Human Machine Interface (HMI).

The IntelliCENTER software features:

- Integration Assistant - takes customized MCC information within the IntelliCENTER software and exports it to Studio 5000, providing quick device integration and reducing programming time.
- IntelliCENTER Energy - energy monitoring and management with integration to FactoryTalk EnergyMatrix software.
- Elevation View - an easy-to-identify, graphical representation of your entire MCC lineup. Status light indicators and customizable text give you instant identification of your motors, machines, or processes.
- Monitor View - an overview of the intelligent motor control device being monitored, with configurable gauges, trend graphs, I/O status on the device and configurable data fields.
- Spreadsheet View - for sorting and editing data that seldom changes, including network address, device type and description, and nameplate data.
- Event Log View - a history of changes to equipment parameters, like trip settings, warnings, and faults.
- Documentation Management - access to the complete documentation for your MCC, including wiring diagrams, device manuals, and spare parts list. Add new documentation (procedures, engineering notes) associated with your MCC and substitute 'as-built' drawings with your 'as-installed' drawings.

All the IntelliCENTER software views are available as ActiveX objects which can be readily accessed by FactoryTalk View software or other HMI software packages. The IntelliCENTER software data set includes network configuration files to generate descriptive tags in your Studio 5000 project.

- Reducing PLC development time with Automatic Tag Generation
- Enabling PLC programmer to complete network configuration before MCC is powered up
- Significantly reducing HMI programming time needed to reproduce these views
- Getting the functionality of all these views by simply configuring the ActiveX object

The screenshot displays the IntelliCENTER software interface. On the left, a 'Drawings' window shows a list of components with columns for Diagram No., Sheet No., and users. The main area is divided into several panels:

- Stratix 5700 Ethernet Switch:** A detailed view of the switch hardware with a text description: "Bulletin 1783 Stratix 5700 Managed Switch uses the current CISCO architecture and feature set. > 6, 10, 18, or 20 ports managed switch > Dual power inputs, input and output alarms, console port, and SFP slots > Operates in temperature range of -40 - 60 C (-40 - 140 F)".
- Real Time Data / Parameters - Switch:** A monitoring panel with three gauges:
 - Bandwidth Utilization:** A gauge showing 0% to 100%.
 - Switch Temperature:** A gauge showing -500 to 500 degrees C.
 - Multicast Groups Active:** A gauge showing 0.0 to 1.0 x1000.
- Real Time Data Trend - Switch:** Two line graphs showing historical data for bandwidth utilization and switch temperature over time.
- Ports:** A grid of 10 ports (1-10) with status indicators.
- Data - Switch:** A list of configuration parameters such as Switch Alarms, Switch Faults, Major/Minor Alarm Relay Bits, Global Threshold Exceeded Status, Switch Update, Ios Release, Ip Address Configuration Capabilit, Host Name, Sd Status, and Global Link Status.

At the bottom of the main interface, there are 'Advanced' and 'Apply' buttons.

IntelliCENTER Database

The IntelliCENTER database contains all of your order-specific information. One IntelliCENTER database is needed for each MCC lineup or for individual units (when the unit is purchased separately). The database is installed on the computer or computers running the IntelliCENTER software. The data set includes the IntelliCENTER data files, all of the electronic documentation, all the up-to-date EDS files for the EtherNet/IP devices and the EtherNet/IP configuration file as recorded during the final system test of the MCC.

The EDS and configuration files are very useful for programming the control system, allowing the programmer to complete the project before the equipment is even energized. Additionally, when used with Studio 5000, the programmer can use the Generator utility in the IntelliCENTER software to instantly generate descriptive tags for every device in the MCC.

The CENTERLINE 2100 Motor Control Centers structure consists of sections, which are made up of wireways, doors, and plug-in or frame mount units. CENTERLINE 2100 MCCs are listed by UL as complying with MCC Standard UL 845.

The rigid, free-standing sections are assembled individually. Shipping blocks are factory assembled from individual sections. Multiple section shipping blocks have continuous lifting angles, horizontal power bars, horizontal ground bus and internal mounting angle.

Bus Design

CENTERLINE bus design means more current carrying capacity per section.

- Standard vertical bus is rated 300 A above and 300 A below the horizontal bus for an effective 600 A capacity per section
- Allows more flexibility for field changes without exceeding vertical bus rating
- Sections available in back-to-back design with separate front and rear vertical bus for maximum loading capacity
- Continuous bus bracing provides more uniform support than commonly used standoffs

Vertical wireway contains no control or power terminations making cable installation safer. For added safety, a permanent barrier separates the vertical wireway from units.

Automatic shutters available to immediately isolate vertical bus when unit is removed.

Computerized fastening system used in the assembly of horizontal to vertical bus connection:

- Reduces periodic maintenance
- Minimizes exposure to hazardous voltage

Dedicated plug-in ground bus is part of a solid grounding system.

Mounting Configurations

The MCC is available in two mounting configurations - front mounted and back-to-back mounted.

- Front mounted sections are joined and installed side-by-side.
- Back-to-back mounted sections are two separate sections joined at the rear without a back plate between sections. The two sections have separate horizontal and vertical power bus systems providing the same phasing for all units, both front and back. The horizontal power bus is linked, front to rear, with a factory installed U-shaped bus splice assembly. Full usage of unit space is available for both front and back sections.

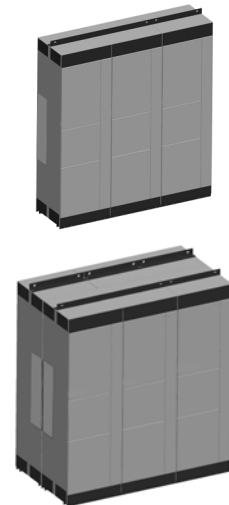

Section Features

The rigid design of CENTERLINE 2100 MCCs helps ensure a longer life in all applications. Fault containment is enhanced with two side sheets on every section. This enhancement helps prevent a single fault from cascading throughout the structure, limiting equipment damage. Plug-in units can still be installed and removed and doors closed securely after years of dependable service.

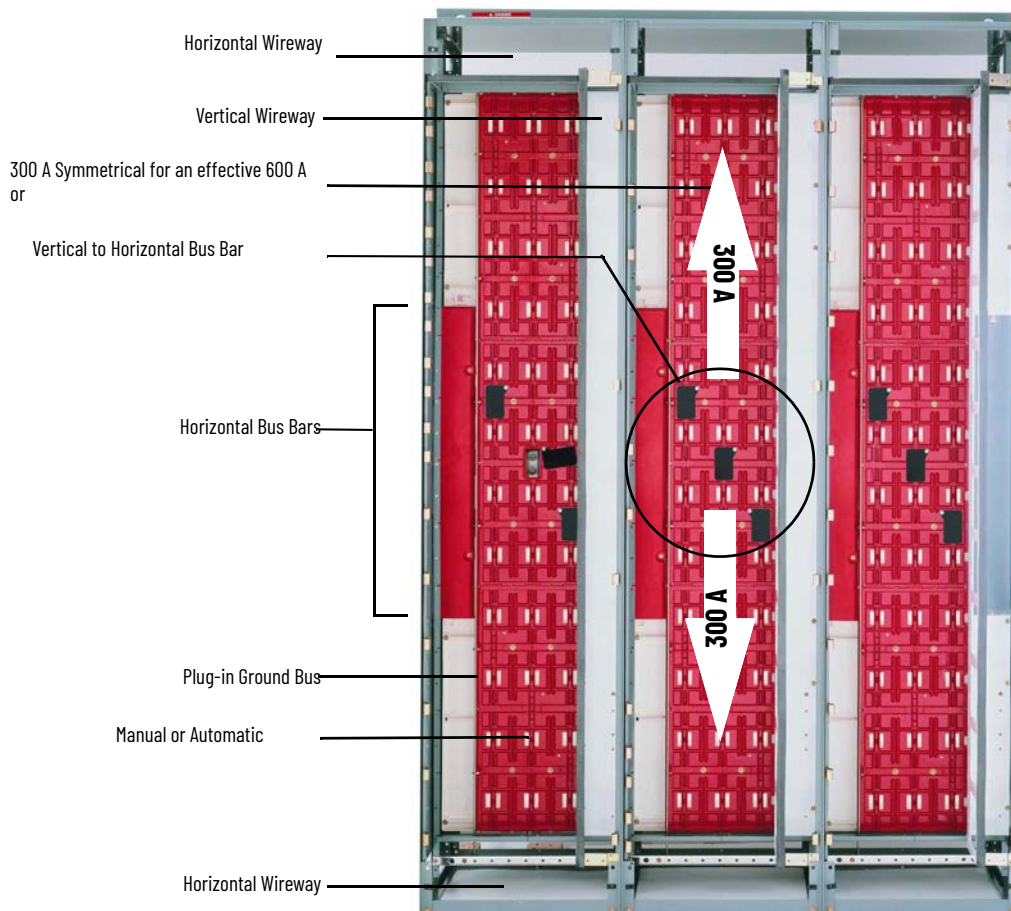

Section Dimensions

The standard dimensions (HxWxD) of a vertical section are 90 x 20 x 15 in. (2286 x 508 x 381 mm). Vertical sections are also available as 20 in. (508 mm) deep. Some vertical sections can be wider than 20 in. (508 mm) due to larger equipment or optional vertical wireway.

Optional 71 in. (1791 mm) reduced height vertical sections are available. These sections can be either 15 in. (381 mm) or 20 in. (508 mm) deep and each 71 in. high vertical section accommodates standard plug-in units up to and including 4.5 space factors.

Dimensions are shown as in. (mm).

Section Dimensions

Height	90 in. (2286 mm) standard; 71 in. (1790 mm) available
Width	20 in. (508 mm) standard; wider sections available for larger equipment in 5 in. (127 mm) increments
Depth	Front mounted 15 in. (381 mm) or 20 in. (508 mm) Back-to-back 30 in. (762 mm) or 40 in. (1016 mm)
Vertical Wireway	4.37 in. (111 mm) wide standard; 9.37 in. (238 mm) wide available

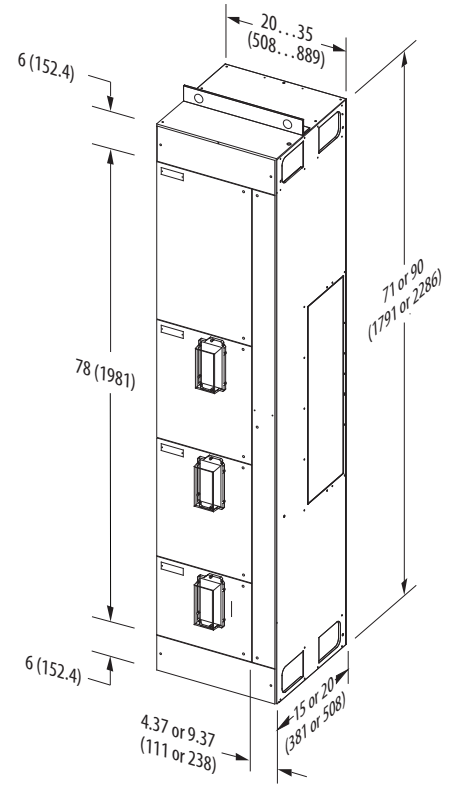

Section Construction

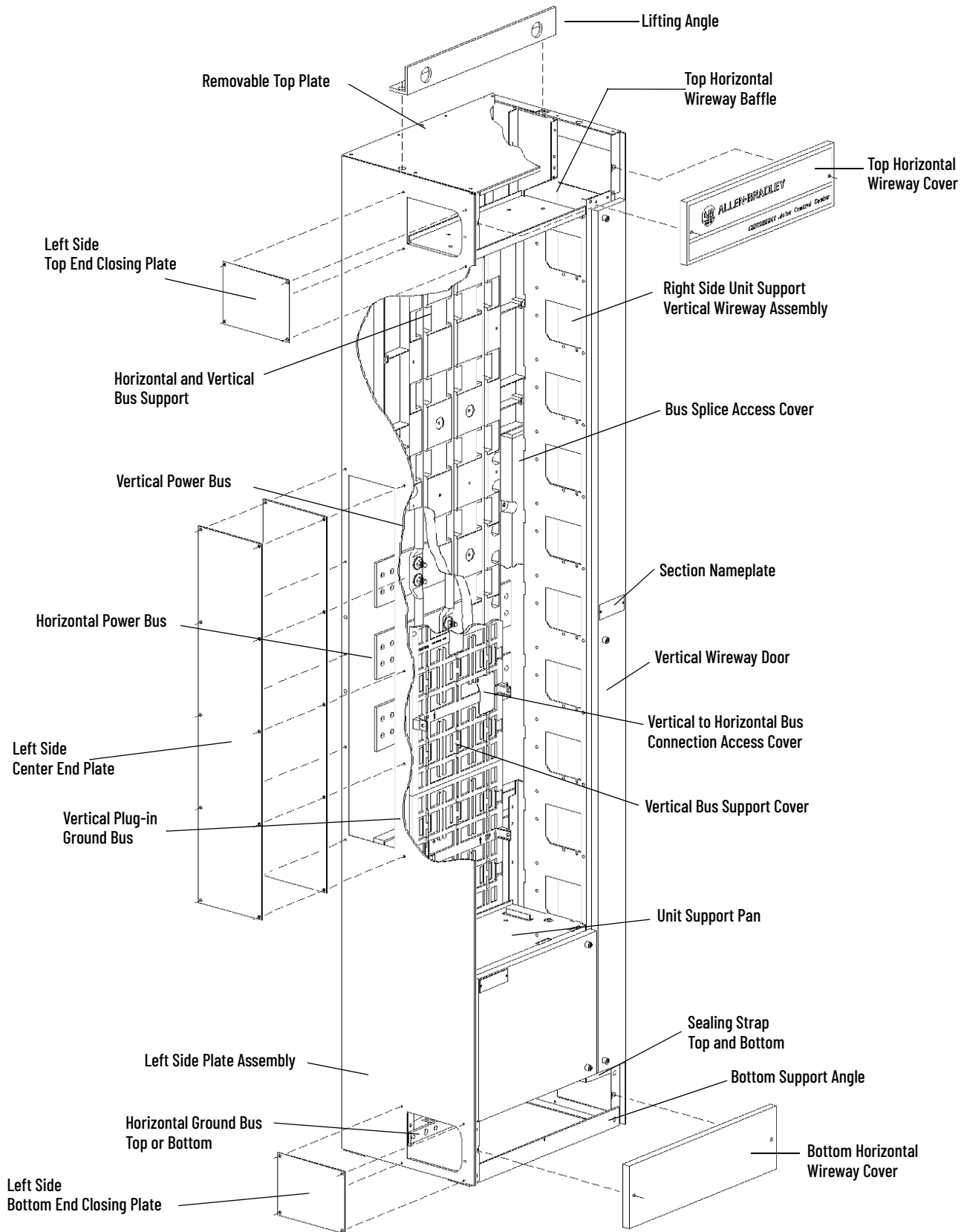

Approximate Weight

This table lists approximate weights for MCC sections. Many factors (number of units, horizontal power bus, wireway width, section depth and width) affect the weight of the sections. Weight is also added when the product is packaged for shipping.

Approximate Weight

MCC Section Dimensions	NEMA/UL Type 1, 1G, or 12 per section listed in lb (kg) ⁽¹⁾
15"/20" D, 20"W, 90" H	500 (227)
15"/20" D, 25"W, 90" H	575 (261)
15"/20" D, 30"W, 90" H	600 (272)
15"/20" D, 35"W, 90" H	650 (295)

(1) Weights are for a typical motor control center with four units per section. Weights do not include packaging. Refer to packing slip shipped with you MCC for exact shipping weights.

NEMA/UL Enclosure Type

Structures are available with the following NEMA/UL Enclosure Type ratings.

- NEMA/UL Type 1
- NEMA/UL Type 1 with gasketing around perimeter of unit doors
- NEMA/UL Type 12
- NEMA/UL Type 3R (non walk-in)
- NEMA/UL Type 4 (non walk-in)

Structure sheet metal has rounded edges and is tightly fitted with no visible air gaps. See Technical Specifications and Certifications, on [page 7](#) for more information.

Operating Environment

The MCC is designed to operate in an ambient operating temperature range of 0...40 °C (32...104 °F) with up to 95% noncondensing humidity.

The MCC is designed to operate at altitudes up to 2000 m (6600 ft) without derating. For MCCs with variable frequency drives, the MCC can be operated at altitudes up to 1000 m (3300 ft) without derating.

Paint and Plating

Structural metal undergoes a multi-step cleaning, rinsing and painting process resulting in complete uniform-thickness, paint coverage. This process is maintained and controlled by ISO 9001 quality standards.

Unpainted surfaces are treated for corrosion resistance.

MCC Finish

NEMA/UL Enclosure Type	Exterior Finish
1, 1G, 12	ANSI 49, Medium Light Grey
3R	High Gloss White (for outside use)
4	Stainless Steel

Interior vertical wireways and unit mounting plates are painted high-visibility gloss white.

Wireways

Each MCC has horizontal and vertical wireways for continuous dedicated wire and cable location.

Horizontal Wireways

Horizontal wireways are located at the top and bottom of each MCC section.

Horizontal wireways extend the full width and depth of the MCC. The top and bottom are horizontal wireways 6 in. (152.4 mm) high. Complete wireway access from front to rear is available for back-to-back configured MCC sections.

Horizontal wireways have removable front covers that are held in place by captive screws. Openings in the side plate of the section allow access to the top and bottom horizontal wireways between joined sections. Plates are provided to cover these openings for sections located at the end of a MCC lineup.

Horizontal wireways are isolated from the power bus. Horizontal wireways for incoming line sections are reduced depth to maintain isolation from the incoming line area.

Vertical Wireway

The vertical wireway is located on the right side of each section and extends 78 in. (1981 mm), between the top and the bottom horizontal wireway. The vertical wireway is approximately 7 in. (178 mm) deep. The standard vertical wireway is 4.37 in. (111 mm) wide. Vertical wireways are also available in 9.37 in. (238 mm) widths.

The vertical wireway is isolated from power bus and is independent of unit space. Vertical wireways are not present in sections with frame-mount units.

Vertical wireways are covered with steel doors and held in place by at least three door latches. Vertical wireway tie bars are available to help you keep your cable wireways organized.

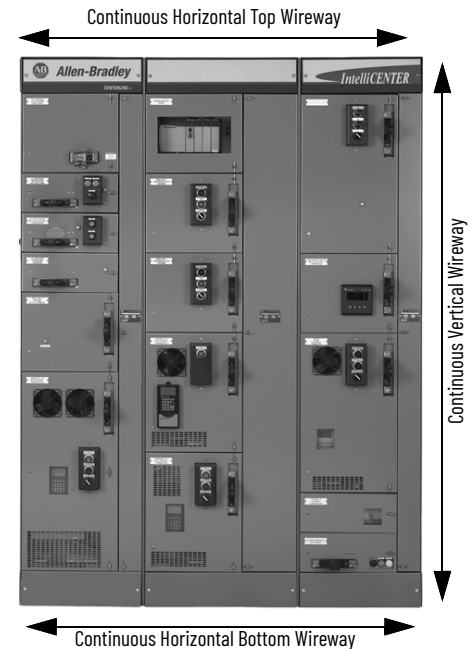

Other Structure-related Options

Other options such as pull boxes, master nameplates and space heaters are available.

The MCC master nameplate, when specified, measure 2.0 x 6.0 in. (50.8 x 152.4 mm) and is available with up to five lines of engraving and is located on the top horizontal wireway cover.

For more information on structure options, see the CENTERLINE 2100 Motor Control Centers Program Guide, publication [2100-CA004](#).

ArcShield Technology

CENTERLINE 2100 MCC with ArcShield technology provides enhanced personnel protection and reduced exposure to arc flash hazards per IEEE C37.20.7-2007, IEEE Guide for Testing Metal-Enclosed Switchgear Rated up to 38 kV for Internal Arcing Faults. Two arc resistant ratings are available: Device Limited and Duration Rated.

ArcShield Technology Availability

Structure	Device Limited ^{(1) (2) (5)}		100 ms Duration Rated ^{(1) (2) (3) (4)}
	600...1200 A	1600...3000 A	600...3000 A
Enclosure			
NEMA/UL 1	Yes	Yes ⁽⁵⁾	Yes ⁽⁵⁾
NEMA/UL 1G	Yes	Yes ⁽⁵⁾	Yes ⁽⁵⁾
NEMA/UL 3R	Yes	No	No
NEMA/UL 12	Yes	Yes ⁽⁵⁾	Yes ⁽⁵⁾
Section Depth	15 in. or 20 in.	20 in.	20 in.
Section Width	20...35 in.	20...35 in.	20...35 in.
Section Height	71 in. or 90 in.	90 in.	90 in.
Back-to-Back	Yes	Yes	Yes
Door Mounted Devices	Yes	Yes	Yes
Vented Units	Yes ⁽⁶⁾	Yes ⁽⁷⁾	No
1/2 Space Factor Units	Yes	No	No
Top-Plate Pressure Relief	No	Yes	Yes
Vertical Wireway Baffle	Not Required	Required	Required
Arc Containment Latches	2 Latches / Door	All Latches	All Latches
Unit Support Pans	Bolted	Bolted	Bolted
Lifting Angle Permanently installed	No	Yes ⁽⁶⁾⁽⁸⁾	Yes ⁽⁸⁾
Vertical Brace Required	No	Yes ⁽⁹⁾	Yes ⁽⁹⁾
Electrical			
Bus Voltage	Up to 600V	Up to 600V	Up to 480V
Available Fault Current	Up to 65 kA	Up to 65 kA	Up to 65 kA
Horizontal Bus Current Rating	Up to 1200 A	Up to 3000 A	Up to 3000 A
Horizontal Ground Bus	Top or Bottom or Both	Top and Bottom	Top and Bottom
Vertical Bus Shutters	Automatic / Manual	Automatic / Manual	Automatic / Manual
Vertical Plug-in Ground Bus	Copper or Copper/Tin	Copper or Copper/Tin	Copper or Copper/Tin
Vertical Load Ground Bus	Optional	Copper or Copper/Tin	Copper or Copper/Tin

- (1) For unit configurations, see option -112A and -112B.
- (2) Refer to Engineering for application notes.
- (3) 20" deep only.
- (4) Duration Rated is available as PE delivery program (without baffles).
- (5) No units with door mounted filters at 600V.
- (6) Arc-resistant baffles are required. Note that baffles are not available on blank doors or empty units.
- (7) Yes at 480V, No at 600V.
- (8) Requires 12 in. clearance above the MCC.
- (9) Requires an additional 1.5 in. clearance on left and right most sections of the MCC.

Units Available with ArcShield Technology

Availability with These Units	Device Limited ^{(1) (2) (3)}		100 ms Duration Rated ^{(1) (2) (3)}
	600...1200 A	1600...3000 A	600...3000 A
SecureConnect	Yes	Yes	Yes
IntelliCENTER Technology	Yes	Yes ⁽⁴⁾	Yes ⁽⁴⁾
Drives	Yes	Yes ⁽⁵⁾	Yes ⁽⁵⁾
SMCs	Yes	Yes ⁽⁵⁾	Yes ⁽⁵⁾
Starters	Yes	All	All
Mains and Feeders	Yes ⁽⁶⁾	Yes ⁽⁶⁾	Yes ⁽⁶⁾
100% Rated Breakers ⁽⁶⁾⁽⁷⁾	No	No	No
Dual Units	Yes	Yes	Yes

- (1) Duration Rated is available as PE delivery program (without baffles).
- (2) For unit configurations, see option -112A and -112B.
- (3) Refer to Engineering for application notes.
- (4) Only available with unit-mounted Ethernet Switch.
- (5) Not available on NEMA/UL 1 if the NEMA/UL 12 version requires venting at 600V.
- (6) Not available with ACBs.
- (7) 100% rated circuit breaker mains are not available due to venting requirements.

ArcShield Features

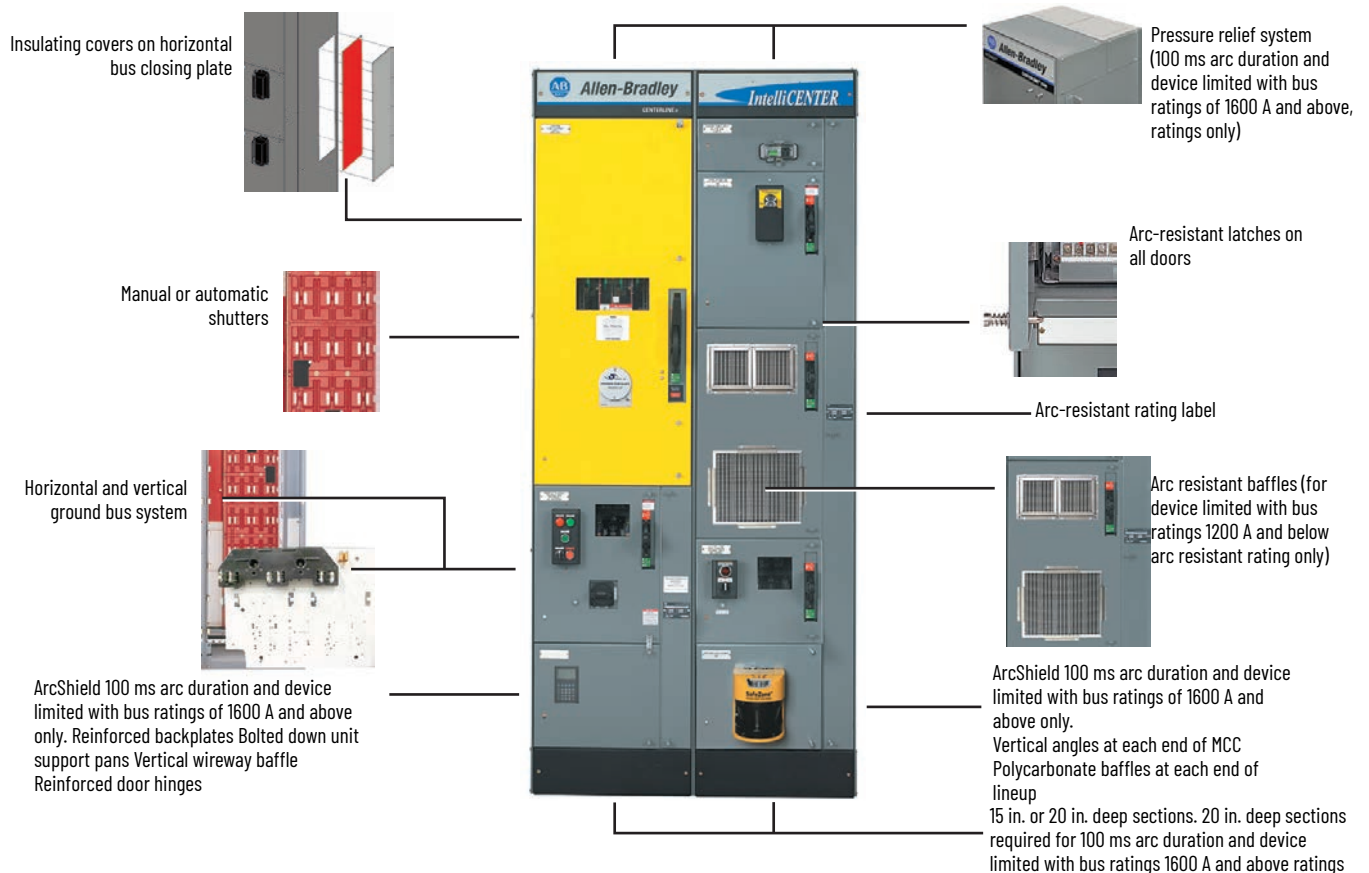

In combination with the standard safety features built into every CENTERLINE 2100 MCC, choosing ArcShield provides you additional benefits, including:

- Type 2 Accessibility for enhanced personnel protection at the front, sides and rear of the MCC.
- Performance tested arc-resistant latches on all doors capable of withstanding the high internal pressure generated by an arc blast keep doors latched and secured to the MCC during an arcing fault.
- Manual or automatic shutters help to protect against potential electrical shock hazards from unused plug-in stab openings.
- Copper vertical ground bus and heavy duty ground stab on plug-in units provides an effective path for ground fault currents which helps to minimize fault clearing times of overcurrent protective devices.
- Insulating covers on horizontal bus closing plates help prevent 'burn through' which can result from arcing faults in the horizontal bus compartment.
- Vented units with arc-resistant baffles to allow for a wider range of MCC equipment for NEMA/UL Type 1 Enclosures while maintaining Type 2 Accessibility (ArcShield with device-limited arc-resistant with max bus rating of 1200 A ratings only).
- Pressure relief system designed to exhaust gases through the top of the enclosure, away from personnel (ArcShield with 100 ms arc duration and device limited with bus ratings of 1600A and above ratings only).

CENTERLINE 2100 MCCs with ArcShield technology can also be supplemented with IntelliCENTER technology. The remote maintenance and troubleshooting capabilities of IntelliCENTER technology keeps you out of the flash boundary and safe from electrical and arc flash hazards. You can perform the following procedures with the unit doors closed:

- Overload detection (monitor warnings and trips)
- Change overload relay setting (full load amperes and trip class)
- Measure and monitor phase currents
- Measure baseline motor currents
- Ground fault detection (monitor warnings and trips)
- Monitor motor thermistor
- Time to trip and time to reset
- Reset overload relays
- Event history
- Verify control power
- Verify starter operation

Step 4: Select Power Bus and Ground Bus Systems

Incoming Power

For further discussion regarding power, see Power System Considerations for Product Selection, publication [2100-AT003](#).

CENTERLINE 2100 Motor Control Centers are designed for use on three-phase, three-wire or four-wire, Wye connected power systems, rated 600V or less, 50 or 60 Hz, with a solidly grounded neutral. CENTERLINE 2100 Motor Control Centers are also suitable for the following power system configurations, however, some units and options are not available:

- 3-phase, 3-wire, Wye systems rated 600V/347V or less, with impedance grounded neutral
- 3-phase, 3-wire, ungrounded Delta systems, rated 600V or less

Power Bus

The CENTERLINE 2100 MCC features the time-proven Allen-Bradley CENTERLINE power bus system. The horizontal power bus is mounted near the vertical center of the structure providing optimum heat dissipation, power distribution, and ease of maintenance and installation.

The vertical power bus allows power distribution both above and below the center-mounted horizontal bus, effectively doubling the capacity in each section. This feature also helps allow a virtually unrestricted unit arrangement.

Horizontal and vertical power buses are fastened together with a two bolt assembly. This two-bolt connection helps minimize the likelihood of 'hot spots'. The factory-made horizontal to vertical power bus connection is tightened by a computerized torquing system.

The power bus system is supported, braced, and isolated by a bus support molded of high strength, non-tracking glass polyester material.

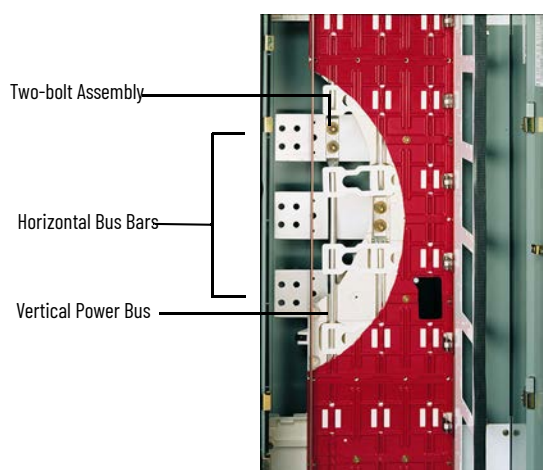

Horizontal Power Bus

The horizontal power bus is available as follows:

- 600...800 A - aluminum with tin plating
- 600...3200 A - copper with tin plating or copper with silver plating

The horizontal power bus is continuous in each shipping block and mounted near the vertical center of the structure providing optimum heat distribution, power distribution and ease of maintenance and splicing. The horizontal power bus is mounted on-edge in a vertical plane providing maximum strength to withstand magnetic forces present during fault conditions. It is mounted in recessed channels of the bus support to protect against accumulation of dust and tracking between phases.

Vertical Power Bus

Vertical power bus bars are cylindrical providing optimum contact with the unit plug-in stabs. Vertical power bus bars are continuously braced by a high strength, non-tracking glass polyester material and sandwiched by a glass filled polycarbonate molded bus cover isolating the vertical power bus from the other vertical phases and the horizontal power bus. The standard vertical power bus is a copper tube rated 300 A above and below the horizontal power bus for an effective 600 A rating. An optional copper rod rated 600 A above and below the horizontal power bus for an effective 1200 A rating is available. The vertical power bus is tin-plated or silver-plated. The plating of the vertical power bus matches the plating of the horizontal power bus.

Horizontal Neutral Bus

The horizontal neutral bus, when required for four-wire systems, is available and can be located above or below the horizontal power bus. Connections to the neutral bus are made through neutral connection plates mounted in the horizontal wireways of various vertical sections or an optional vertical neutral bus located in a 9 in. (228 mm) wide vertical wireway.

Bracing

Fully rated bus bracing is available at 42, 65, or 100 kA rms symmetrical. Series-coordinated bus bracing is also available at 100 kA rms symmetrical. Series-coordinated bus bracing, when used with specific current-limiting mains, provides a cost-effective alternative to 100 kA fully rated bus bracing.

Ground Bus Types

Horizontal Ground Bus

The horizontal ground bus is available as unplated copper or tin-plated copper and can be located in the top and/or bottom horizontal wireway. The horizontal ground bus is available as 0.25 x 1 in. (6.35 x 25.4 mm) or 0.25 x 2 in. (6.35 x 50.8 mm).

The 1/4 x 1 in. (6.35 x 25.4 mm) horizontal ground bus has an effective 500 A continuous rating and the 1/4 x 2 in. (6.35 x 50.8 mm) horizontal ground bus has an effective 900 A continuous rating. The horizontal ground bus has various sized holes evenly spaced along the length for making ground connections. A pressure type mechanical lug is mounted on the horizontal ground bus in the incoming line section. An outgoing equipment ground lug can also be mounted on the horizontal ground bus.

Vertical Plug-in Ground Bus

The vertical plug-in ground bus is mechanically connected to the horizontal ground bus forming a complete internal ground system in each standard vertical section. The vertical plug-in ground bus in combination with the unit ground stab establishes a first make, last break operation of the ground connection with respect to the power connects.

The 0.1875 x 0.750 in. (4.74 x 19.05 mm) vertical plug-in ground bus can be:

- zinc plated steel.
- unplated copper.
- tin-plated copper.

Vertical Bus Plug-in Stab Opening Protection

Several options are available for covering unused plug-in stab openings:

- Protective caps
- Manual shutters
- Automatic shutters

Automatic shutters open as plug-in units are inserted and close when the unit is removed. Automatic shutters help ensure the vertical bus is immediately isolated when a plug-in unit is removed.

Vertical Unit Load Ground Bus

The vertical unit load ground bus is mechanically connected to the horizontal ground bus. The vertical unit load ground bus in combination with the unit load connector provides a termination point for the load ground cable at the unit. This fixed connection does not need to be removed when withdrawing the unit from the MCC.

The 0.1875 x 0.750 in. (4.74 x 19.05 mm) vertical unit load ground bus can be unplated or tin-plated copper.

Unit Size

Unit size is described in space factors. Units are designed in 0.5 space factor increments. Each 0.5 space factor is 6.5 in. (165.1 mm) high. Each standard, 90 in. high MCC section can contain 6.0 space factors. Up to twelve 0.5 space factor units can be placed in a section.

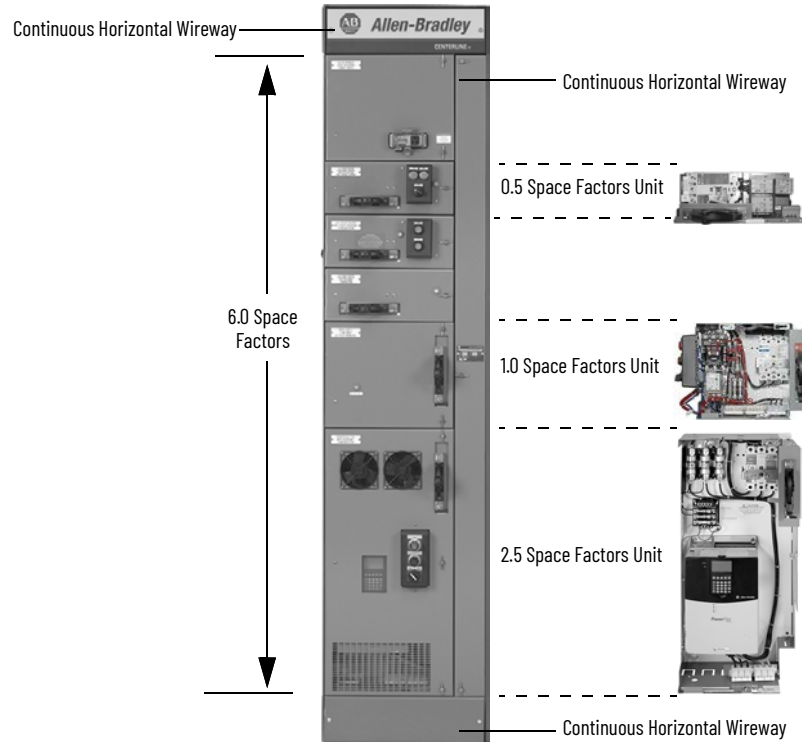

Plug-in Unit Design Features

Plug-in units consist of the unit, unit support pan and unit door. Plug-in units are held securely in the section when inserted and are designed with an interlock to help ensure that units cannot be inserted or withdrawn when the disconnect means is in the ON/I position.

Frame Mounted Unit Design Features

Frame mounted units are permanently mounted in the section, all connections are made directly to the components. Fixed units range from 1 space factor to 6 space factors.

Disconnect Handle Mechanism

Flange style disconnect handles (vertical or horizontal mounted) are provided with units with disconnects.

The disconnect handle of all units is interlocked with the unit door so the disconnect means cannot be switched to the ON/I position unless the door is closed. This interlock also prevents you from opening the unit door unless the disconnect is in the OFF/O position. An externally operated defeater is provided if access to the unit is needed without interrupting service. The interlock also prevents the unit from being inserted or removed when the disconnect handle is in the ON/I position.

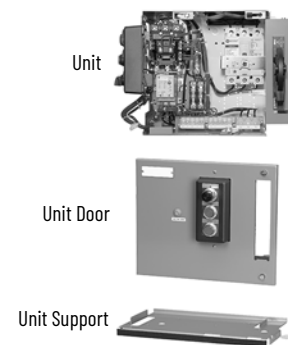

Unit Disconnect



Fusible disconnect switches are available in MCC units. The fusible disconnect switches have visible blade type movable contacts and supplied with Class J, R, H, L, or CC fuse clips. NEMA space saving starter units are limited to Bulletin 194R fusible disconnect switch with Class CC fuse clips. Fusible disconnect requirements above 400 A use a bolted pressure contact switch with visible blade disconnect mechanism.

Circuit breaker disconnects are available in MCC units. Horsepower rated MCC units are provided with instantaneous circuit breakers (HMCP) or with inverse time (thermal magnetic or electronic) circuit breakers. Current rated units are provided with inverse time (thermal magnetic or electronic) circuit breakers.

SecureConnect Units

SecureConnect units let you disconnect the power from an individual MCC plug-in unit without opening the enclosure door. These units provide electrical and mechanical indications that the unit is disconnected from the vertical power bus. When turning the handle on the front of the unit to the 'Off' position, the power stabs disengage and retract inside the power stab housing.



SecureConnect Technology Availability

Bulletin	Size 1	Size 2	Size 3	Size 4	Size 5
2106/2107	✓	✓	✓	✓	--
2112/2113	✓	✓	✓	✓	--
2122/2123	✓	✓	✓	✓	--
2154/2155	✓	✓	✓	✓	--
2162/2163	✓	✓	✓	_(1)	--

	30 A	60 A	100 A	200 A	400 A
2192	✓	✓	✓	✓	_(1)

	G-Frame / H-Frame	J-Frame	K-Frame
2193	✓ (2)	✓	--

(1) SecureConnect technology is not applicable to frame-mount units.

(2) Not available with 3 A and 7 A MCP circuit breakers.

Stab Assembly

The two-piece power stab housing is made of high strength, non-tracking glass polyester material and provides a separate, isolated pathway for each phase.

The power cable connection at the plug-in stab is made with a maintenance free crimp style connection. There is no exposed wiring at the back of the unit between the disconnecting means and the plug-in stabs.



Unit plug-in power stabs are rated 225 A. The stabs are made of tin-plated copper for a low resistance connection and are designed to tighten during heavy current surges.

The free-floating and self aligning unit plug-in power stabs are backed by stainless steel spring clips to provide and maintain a high pressure, four-point connection to the vertical power bus.

Pilot Devices

Pilot devices are housed in a door mounted control station. Each control station can accommodate up to three 30.5 mm or four 22.5 mm devices.

The control station is easily removed from the unit door using captive screws. If a control station is removed, closing plates are available to cover the opening in the unit door and provide isolation, allowing the control station to stay with the unit when the unit is removed.

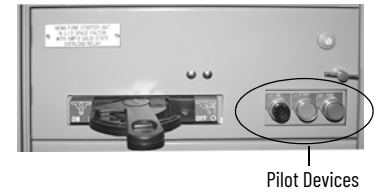

Unit Doors

Each unit is provided with a removable door mounted on removable pin type hinges which allow the door to open at least 110 degrees. The unit doors are removable from any location in the MCC without disturbing any other unit doors. The unit door is fastened to the structure so it can be closed to cover the unit space when the unit is removed. The unit doors are held closed with 1/4-turn latches. Units with overload relays have a low profile external reset button.

Unit Nameplates

Unit nameplates measuring 1.125 x 3.375 in. (28.58 x 85.73 mm) are available and can accommodate three or four lines of engraving. The following types of unit nameplates are available:

- Acrylic plate - Lettering is white with black letters or black with white letters.
- Clear cardholders - Supplied with blank cards.
- Door Nameplate Screws - Plated steel nameplate screws. Provided when cardholder or nameplates are not selected.

Nameplates are secured using two steel self-tapping screws. Stainless steel screws are also available.



Step 6: Select Unit Types

You can choose from a variety of units including contactor and starter units, metering units, main and feeder units, lighting and power panel units, transformer units, combination soft starter units, variable frequency AC motor drive units and programmable controller units. Contact your local Allen-Bradley distributor or Rockwell Automation sales representative for catalog numbers and complete selection rules.

Contactor and Starter Units

Combination Full-voltage Lighting Contactor Units (FVLC)

These combination lighting contactor units are supplied with an Allen-Bradley Bulletin 500L AC contactor and either a fusible disconnect or circuit breaker. They are rated 30...300 A. Each unit is provided as a NEMA Class I, Type B-T unit with terminals mounted in the unit for connection to remote devices. These full voltage reversing units are available with electronic overload relays.

Bulletins 2102L and 2103L - Full Voltage Lighting Contactor Unit with Fusible Disconnect Switch or Circuit Breaker (FVLC)

Rating (A)	Transformer Primary Switching kVA										Bulletin 2102L			Bulletin 2103L	
	208V		240V		380V...415V		480V		600V		Fuse Clip		Space Factor ⁽¹⁾	Circuit Breaker Frame	Space Factor ⁽¹⁾
	Phase										Rating (A)	Class			
	Single	Three	Single	Three	Single	Three	Single	Three	Single	Three					
30	1.2	3.6	2.4	4.3	2.8	7.1	4.9	8.5	6.2	11	30	CC, J	0.5	G6C3, H6C3, HOC3, J15C3, J15H3	0.5
30	1.2	3.6	2.4	4.3	2.8	7.1	4.9	8.5	6.2	11	30	CC, J, R, H	1.0		1.0
DUAL 30	1.2	3.6	2.4	4.3	2.8	7.1	4.9	8.5	6.2	11	—	—	—		1.5
60	2.1	6.3	4.1	7.2	6.8	11.8	8.3	14	10	18	30, 60	J, R, H	1.0		1.0
DUAL 60	2.1	6.3	4.1	7.2	6.8	11.8	8.3	14	10	18	—	—	—		1.5
100	4.1	12	8.1	14	13.3	23.3	16	28	20	35	60, 100	J, R, H	2.5	G6C3, H6F3, HOF3, J15F3, J15H3, H6C3, HOC3, J15C	1.5
200	6.8	20	14	23	22.5	39	27	47	34	59	100, 200		3.0	J6C3, J6F3, JOC3, JOF3, J15C3, J15F3	2.5
300	14	41	27	47	45	78.3	54	94	68	117	200, 400		4.0	J6C3, J6F3, JOC3, JOF3, J15C3, J15F3, K6H3, KOH3, K15H3	3.5

(1) Adding options can increase the space factor of the unit.

Combination Full Voltage Reversing Starter Units (FVR)

These combination full voltage reversing starter units are supplied with an Allen-Bradley Bulletin 505 reversing starter and either a fusible disconnect or a circuit breaker. The Bulletin 2106 and 2107 starters are rated for NEMA sizes 1 through 5 and are mechanically and electrically interlocked to avoid both contactors being closed simultaneously. Each unit is provided as a NEMA Class I, Type B-T unit with terminals mounted in the unit for connection to remote devices. Full voltage reversing starter units are available with an electronic overload relay.

Bulletins 2106 and 2107 - Full Voltage Reversing Starter Unit with Fusible Disconnect Switch or Circuit Breaker (FVR)

NEMA Size	Horsepower	Bulletin 2106		Bulletin 2107				
	480/600V	Fuse Clip		Space Factor ⁽¹⁾	Circuit Breaker Frame	Space Factor ⁽¹⁾		
		Rating (A)	Class					
1	0.125...10	30	CC, J, R, H	1.5	G8P, H8P, G6C3, HOC3, H6C3, H15H3, J15H3	1.5		
		60	J, R, H					
2	15...25	30, 60, 100	J, R, H	1.5		G8P, H8P, G6C3, HOC3, H6C3, H15H3, J15H3	1.5	
		100	R, H	2.0				
3	30...50	60, 100	J, R, H	3.0			G8P, H8P, G6C3, HOC3, H6C3, H15H3, J15H3	2.5
		200	J, R, H	3.5				
4	60...100	100, 200, 400	J, R, H	4.0	J8P, J6F3, JOF3			4.0
5	125...200	200, 400, 600	J, R, H	6.0, 20"W	K8P, K6H3, KOH3, K15H3			6.0, 20"W

(1) Adding options can increase the space factor of the unit.

Space Saving NEMA Combination Full Voltage Reversing Starter Units (FVR) - Bulletin 2106 and 2107

These combination full voltage reversing starter units offer a space saving alternative while utilizing an Allen-Bradley Bulletin 300 reversing starter and either a fused disconnect or a circuit breaker. The Bulletin 2106 Space Saving NEMA reversing starters are rated for NEMA Size 1 applications and the Bulletin 2107 Space Saving NEMA reversing starters are rated for NEMA Size 1 through 3 applications. The contactors are mechanically and electrically interlocked to avoid both contactors being closed simultaneously.

Each unit is provided as a NEMA Class I, Type B-D unit with terminals mounted in the unit for connections to remote devices. These full voltage reversing units are available with electronic overload relays.

Bulletins 2106 and 2107 - Space Saving NEMA Full Voltage Reversing Starter Unit with Fused Disconnect Switch (FVR) or Circuit Breaker (FVR)

NEMA Size	Horsepower		Bulletin 2106			Bulletin 2107	
	480V	600V	Fuse Clip		Space Factor ⁽¹⁾	Circuit Breaker Frame	Space Factor ⁽¹⁾
			Rating (A)	Class			
1	0.5...10	0.75...10	30	CC, J	0.5	G8P, H8P, H15H3, G6C3, H6F3, HOC3, HOF3	0.5
2	15...25	15...25	—	—	—		1.0
3	30...50	30...50	—	—	—		1.5

(1) Adding options can increase the space factor of the unit.

Combination Full Voltage Non-reversing Starter Units (FVNR)

These combination full voltage non-reversing starter units are supplied with an Allen-Bradley Bulletin 509 or Bulletin 300 starter and either a fusible disconnect or a circuit breaker. The full voltage non-reversing starters are rated for NEMA sizes 1 through 6. Each unit is provided as a NEMA Class I, Type B-T unit, with terminals mounted in the unit for connection to remote devices. Full voltage non-reversing starter units are available with an electronic overload relay.



Bulletins 2112 and 2113 - Full Voltage Non-reversing Starter Units with Fusible Disconnect Switch or Circuit Breaker (FVNR)

NEMA Size	Horsepower 480/600V	Bulletin 2112			Bulletin 2113	
		Fuse Clip		Space Factor ⁽¹⁾	Circuit Breaker Frame	Space Factor ⁽¹⁾
		Rating (A)	Class			
1	0.125...10	30	CC, J	0.5	G8P, H8P, G6C3, H6C3, HOC3, H15H3, J15H3, J15C3	0.5
1	0.125...10	30	CC, J, R, H	1.0	G8P, H8P, G6C3, H6C3, HOC3, H15H3, J15H3, J15C3	1.0
		60	J, R, H			
DUAL 1	0.125...10	—	—	—	G8P, H8P, G6C3, H6C3, HOC3, H15H3, J15H3, J15C3	1.5
2	15...25	30 60 100	J, R, H J, R, H J	1.0	G8P, H8P, G6C3, H6C3, HOC3, H15H3, J15C3	1.0
		100	R, H	1.5		
DUAL 2	15...25	—	—	—	G8P, H8P, G6C3, H6C3, HOC3, H15H3, J15C3	1.5
3	30...50	60 100	J	2.0	G8P, H8P, G6C3, H6F3, HOF3, J15F3	1.5 ⁽²⁾
		200	J	2.5		
	—	60 100	R, H	2.5		2.0 ⁽³⁾ ₍₃₎
		200	R, H	3.0		
4	60...100	100 200	J	2.5	J8P, J6F3, JOF3, KOH3, K6H3, K15H3, K8P	2.0 ⁽²⁾
		400	J	3.0		
		100, 200	R, H R, H	3.0		2.5 ⁽³⁾
5	125...200	200 400 600	J J J	3.5	K8P, K6H3, KOH3, K15H3, J6F3, JOF3	3.5
		200 400	R, H R, H	4.0		
6	250...400	400 600 800	R, H J, R L	6.0 25"W	M8P, M6H3, MOH3, K6H3, KOH3, K15H3, K8P	6.0 25"W
		400, 600, 800	R, H J, R			

(1) Adding options can increase the space factor of the unit.

(2) Applies only to 480/600V horsepower models.

(3) Applies to all horsepower models except 480/600V.

Combination Vacuum Full Voltage Non-reversing Starter Units (FVNR)

These combination full voltage non-reversing starter units are supplied with an Allen-Bradley Bulletin 1102C contactor and either a fusible disconnect or a circuit breaker. The full voltage non-reversing vacuum starters are rated 200 A, 400 A or 600 A. Each unit is provided as a NEMA Class I, Type B unit, with terminals mounted in the unit for connection to remote devices. Full voltage non-reversing vacuum starter units are available with an electronic overload relay.

Bulletins 2112 and 2113 Vacuum Full Voltage Non-reversing Starter Unit with Vacuum Contactor and Fusible Disconnect Switch or Vacuum Contactor and Circuit Breaker (FVNR)

Rating (A)	Horsepower		Disconnect Switch Rating (A)	Bulletin 2112		
	480V	600V		Fuse Clip		Space Factor ⁽¹⁾
				Rating (A)	Fuse Class	
200	60...125	60...150	200	100	J, R, H	3.5
				200		
				400	J	
	150	200	400	200	J, R, H	4
400				J		
400	200	250	400	200	J, R, H	4.5
				400		
				600	J	
	250...300	300...400	600	400	J, R, H	6.0, 20"W
600				J		
400				J, R, H		
600	350	—	600	400	J, R, H	
				600	J	

(1) Adding options can increase the space factor of the unit.

Rating (A)	Horsepower		Bulletin 2113	
	480V	600V	Circuit Breaker Frame (A)	Space Factor ⁽¹⁾
200	60...100	60...150	250AF	3.5
	125	125...150	400AF	
400	125...200	200	800AF	4
	—	250		6.0, 20"W
600	250...300	300...400	—	6.0, 20"W
	350	—		

(1) Adding options can increase the space factor of the unit.

Space Saving NEMA - Combination Full Voltage Non-Reversing Starter Units (FVNR)

These combination full voltage non-reversing starter units offer a space saving alternative while utilizing an Allen-Bradley Bulletin 300 starter and either a fused disconnect or a circuit breaker. The Bulletin 2112 Space Saving NEMA non-reversing starter units are rated for NEMA Size 1 applications and the Bulletin 2113 Space Saving NEMA non-reversing starter units are rated for NEMA Size 1 through 4 applications. Each unit is provided as a NEMA Class I, Type B-D unit with terminals mounted in the unit for connections to remote devices. These full voltage non-reversing units are available with electronic overload relays.

Bulletins 2112 and 2113 - Space Saving NEMA Full Voltage Non-reversing Starter Unit with Fused Disconnect Switch or Circuit Breaker (FVNR)

NEMA Size	Horsepower		Bulletin 2112			Bulletin 2113	
	480V	600V	Fuse Clip		Space Factor ⁽¹⁾	Circuit Breaker Type	Space Factor ⁽¹⁾
			Rating (A)	Class			
1	0.5...10	0.75...10	30	CC, J	0.5	G8P, H8P, H15H3, G6C3, H6F3, H0C3, H0F3, H6C3	0.5
2	15...25	15...25	—	—	—		
3	30...50	30...50				—	—
4	60...100	60...100	—	—	—		

(1) Adding options can increase the space factor of the unit.

Combination 2-Speed Starter Units (TS2W and TS1W)

These combination two-speed starter units are supplied with an Allen-Bradley Bulletin 520 starter and either a fusible disconnect or a circuit breaker. The 2122 and 2123 starter units are designed for use with motors having separate windings or consequent pole windings. The 2122E, 2123E, 2122F and 2123F are rated for NEMA sizes 1 through 5. Each unit is provided as a NEMA Class I, Type B-T unit, with terminals mounted in the unit for connection of remote devices. Two-speed starter units are available with an overload relay.

Bulletins 2122E and 2123E - Two Speed, 2-Winding Starter Unit with Fusible Disconnect Switch or Circuit Breaker (TS2W)

NEMA Size	Constant or Variable Torque Horsepower 480/600V	Bulletin 2122E			Bulletin 2123E	
		Fuse Clip		Space Factor ⁽¹⁾	Circuit Breaker Type	Space Factor ⁽¹⁾
		Rating (A)	Class			
1	0.125...10	30	CC, J, R, H	2.0	G8P, H8P, G6C3, HOC3, H6C3, H15H3, J15H3, J15C3	2.0
		60	J, R, H			
2	15...25	30	J, R, H	2.0	G8P, H8P, G6C3, H6C3, HOC3, H15H3, J15C3	2.0
		60	J, R, H			
		100	J, R, H			
3	30...50	60	J, R, H	3.0	G8P, H8P, G6C3, H6F3, HOF3, J15F3	3.0
		100	J, R, H			
		200	J, R, H			

(1) Adding options can increase the space factor of the unit.

Bulletins 2122F and 2123F - Two Speed, 1-Winding Starter Unit with Fusible Disconnect Switch or Circuit Breaker (TS1W)

NEMA Size	Constant or Variable Torque Horsepower 480/600V	Bulletin 2122F			Bulletin 2123F	
		Fuse Clip		Space Factor ⁽¹⁾	Circuit Breaker Type	Space Factor ⁽¹⁾
		Rating (A)	Class			
1	0.125...10	30	CC, J, R, H	2.0	G8P, H8P, G6C3, HOC3, H6C3, H15H3, J15H3, J15C3	2.0
		60	J, R, H			
2	15...25	30	J, R, H	2.0	G8P, H8P, G6C3, H6C3, HOC3, H15H3, J15C3	2.0
		60	J, R, H			
		100	J, R, H			
3	30...50	60	J, R, H	4.0	G8P, H8P, G6C3, H6F3, HOF3, J15F3	3.5
		100	J, R, H			
		200	J, R, H			

(1) Adding options can increase the space factor of the unit.

Metering Units

Bulletin 2190 metering units are used for power management of three-phase systems and include analog ammeter and voltmeter, and PowerMonitor™ 5000 units. The ammeter, voltmeter, digital meter, and PowerMonitor 5000 units include a 30 A fused disconnect switch.

Bulletin 2190 - Metering Units

Meter Type	Description	Line Voltage (V AC)	Space Factor ⁽¹⁾
Analog Metering Compartments			
Door Mounted Analog Ammeter ⁽²⁾	One current transformer and panel type ammeter.	600 Max.	0.5 or 1.0
Door Mounted Analog Ammeter with Ammeter Switch ⁽²⁾ ⁽³⁾	Two or three current transformers, panel type ammeter and ammeter switch.		0.5 or 1.0

Bulletin 2190 - Metering Units (Continued)

Plug-in Analog Ammeter and Voltmeter with Switches ⁽³⁾ (4)	Two or three current transformers, panel type ammeter with ammeter switch, two (2) fused potential transformers and panel type voltmeter with voltmeter switch.	208...600	1.0
--	---	-----------	-----

Digital Metering Compartments

PowerMonitor 5000, (Bulletin 1426-M5), with EtherNet/IP Communication	Plug-in unit with disconnect, fuses, and control circuit transformer.		1.5
---	---	--	-----

(1) No disconnect means, no unit insert.

(2) Use on 3-phase, 3-wire systems only.

(3) Units with disconnect and fuses.

(4) Adding options can increase the space factor of the unit.

Main and Feeder Units

Outgoing Feeder Lug Compartment (FLUG) and Incoming Main Lug Compartment (MLUG)

Line lug compartments provide a lug connection for incoming lines (2191M) to distribute power to the CENTERLINE 2100 MCC or for outgoing cables (2191F) to feed power from the MCC to an external load. These line lug compartments are available with ratings from 300...2000 A. Optional mechanical or crimp lugs can be supplied with the lug compartments.

Bulletins 2191M and 2191F - Lug for Basic Sections

Rating (A)	Cable Provisions Maximum Number Per Phase and Maximum Cable Size			Space Factor ⁽¹⁾	Feeder (Bulletin 2191F)		Main (Bulletin 2191M)	
	Mechanical Type Lugs		Crimp Type Lugs		Top	Bottom	Top	Bottom
	Single Cable Lug	Multiple Cable Lug						
300	(2) 400 kcmil	—	(2) 350 kcmil	1.0	x	x		
				1.0			x	x
600	(2) 400 kcmil	(4) 250 kcmil	(2) 350 kcmil	1.0	x	x		
				1.0			x	x
	(1) 500 kcmil	(2) 300 kcmil	(2) 350 kcmil	In top, horizontal wireway			x	x
	(2) 750 kcmil	(4) 500 kcmil	750 kcmil 500 kcmil	1.5			x	x
800	(4) 800 kcmil	—	(4) 750 kcmil	6.0, 20"W	x	x	x	x
800	(2) 800 kcmil (4) 600 kcmil	—	(2) 750 kcmil (4) 500 kcmil	1.0	x ⁽²⁾		x ⁽²⁾	
				1.5	x	x	x	x
	(1) 750 kcmil (2) 600 kcmil (4) 500 kcmil	—	500 kcmil 350 kcmil	2.0	x	x	x	x
800	(4) 800 kcmil	—	(4) 750 kcmil	6.0, 20"W	x	x	x	x
1200	(2) 800 kcmil (4) 600 kcmil	—	(2) 750 kcmil (4) 500 kcmil	1.0	x		x	
				2.0	x	x	x	x
1200	(4) 800 kcmil	—	(4) 750 kcmil	6.0, 20"W	x	x	x	x
1600		—			x	x	x	x
2000		(6) 800 kcmil			—	(6) 750 kcmil	x	x

(1) Adding options can increase the space factor of the unit.

(2) Requires pull-box to meet N.E.C. bending space requirements.

Lug Compartments for Inside Corner, 10" Wide Sections and Neutrals/Incoming Line and Outgoing Feeders

Section	Rating (A)	Cable Provisions Maximum Number Per Phase and Maximum Cable Size		Space Factor ⁽¹⁾
		Mechanical Type Lugs		
		Single Cable Lug	Crimp Type Lugs	
Inside Corner	600...2000	(4) 800 kcmil	(4) 750 kcmil	6.0
10" Wide	600...1200	Not Applicable	(2) 750 kcmil (4) 500 kcmil	6.0

(1) Adding options can increase the space factor of the unit.

Lug Compartments/Incoming Lines Metering Options

Meter Type ⁽¹⁾	Description	
Analog Ammeter	Includes one current transformer and panel type ammeter.	
Analog Ammeter with Ammeter Switch	Includes two current transformers, panel type ammeter, and ammeter switch. Use on three-phase, three-wire systems only.	
	Includes three current transformers, panel type ammeter, and ammeter switch. Use on three-phase, three-wire systems only.	
Analog Voltmeter	Includes one fused potential transformers (mounted in a compartment) and panel-type voltmeter.	
Analog Voltmeter with Voltmeter Switch	Includes two fused potential transformers (mounted in a compartment), panel-type voltmeter, and voltmeter switch. For three-phase, three-wire systems only.	
Analog Ammeter and Voltmeter with Switches ⁽²⁾	Two current transformers, panel type ammeter with ammeter switch, two fused potential transformers, and panel type voltmeter with voltmeter switch.	
	Three current transformers, panel type ammeter with ammeter switch, two fused potential transformers, and panel type voltmeter with voltmeter switch.	

(1) Metering not available in 2191M 600 A main lugs in horizontal wireway.

(2) For three-wire power systems where L1-N, L1-G, L2-N, L2-G, L3-N, or L3-G can exceed 347V. Contact your local authorized Allen-Bradley distributor or Rockwell Automation sales office for more information.

Feeder and Main Fusible Disconnect Switch Units (FDS, MFDS)

These switches are available with ratings from 30...2000 A. The 2192F is a plug-in unit for ratings up to 200 A and frame mounted for ratings 400 A and above. The 2192M is frame mounted (rigidly mounted and hardwired) in the structure for all ratings. The bolted pressure switch design is used for 2192 units rated 600...2000 A.

Select disconnect switch rating based upon 125% of actual load amperes.

Bulletin 2192F Fusible Disconnect Switch—Feeders (FDS)

Switch Rating (A)	Fuse Clip		Load Lugs Provided			Space Factor ⁽¹⁾				
	Rating (A)	Class	Cables/ Phase	Cable/Wire Size Range	Wire Type					
30	30	CC, J	1	#14-#8 AWG	CU	0.5				
30	30	CC, J, R, H		#14-#4 AWG		CU	1.0			
60	60	J, R, H					#14-#4 AWG	CU	1.0	
Dual 30	30									1.0
Dual 60/30	60/30									
Dual 60	60									
Dual 100/30	100/30				1.5					
Dual 100/60	100/60									
Dual 100	100									
100	100	J, R, H, L		#8-1/0 AWG	CU/AL	2.0				
200	200			#6-250 kcmil						
400	400			2			#1/0-300 kcmil	2.5		
600	600		2	#2-600 kcmil			3.5			
800	800		L	3			#6-350 kcmil	3.5		
1200	1200			4			#6-350 kcmil	3.5		

(1) Adding options can increase the space factor of the unit.

Bulletin 2192M Fusible Disconnect Switch—Mains (MFDS)

Switch Rating (A)	Fuse Clip		Line Lugs Provided			Space Factor ⁽¹⁾
	Rating (A)	Class	Cables/Phase	Cable/Wire Size Range	Wire Type	
100	100	J, R, H	1	#8-1/0 AWG	CU	1.5
200	200		1	#6-250 kcmil	CU/AL	2.0
400	400		2	1/0-300 kcmil	CU/AL	2.5
600	600	J, R, H, L	2	#2-600 kcmil	CU/AL	3.5
800	800	L	3	#6-350 kcmil	CU/AL	
1200	1200		4	#6-350 kcmil	CU/AL	
1600	1600		4	#2-600 kcmil	CU/AL	6.0, 20" D, 35"W
2000	2000	6	#2-600 kcmil	CU/AL		

(1) Adding options can increase the space factor of the unit.

Feeder and Main Circuit Breaker Units (FCB, MCB)

Bulletin 2193F and 2193M are circuit breaker units with trip ratings available from 15...2000 A. These units are available with thermal magnetic trips up to 400 A and electronic trips 600 A and above. The 2193F is a plug-in unit for ratings up to 225 A and is a frame mounted unit for ratings 400 A and above. The 2193M is frame mounted for all ratings.

Bulletin 2193F 3-Pole Feeder Circuit Breaker (FCB)

Frame			Range of Available Trips (A)	Short-circuit Current Ratings (rms symmetrical A)		Space Factor ⁽¹⁾
Rating	Type Style	Type		480V	600V	
125 A A	Thermal Mag	TGM	15...100	65k	—	0.5
			15...125			
125 A B	Thermal Mag	THM	15...125	65k	25k	1.0
		THX		100k	35k	
	LSI	THML	25, 60, 100, 125	65k	25k	
		THXL		100k	35k	
	Thermal Mag	THM	15, 20, 30...100	65k	25k	0.5
		THX		100k	35k	
LSI	THML	25, 60, 100, 125	65k	25k		
	THXL		100k	35k		
160 A C (16)	LSI	TJU	30...150	—	100k	0.5
		TJUL	15, 40, 60, 100, 150			
		TJU	30...150			
		TJUL	15, 40, 60, 100, 150			1.0
250 A C	Thermal Mag	TJM	70, 90...225	65k	25k	1.5
		TJX		100k		
	LSI	TJML	100, 150, 250	65k	35k	
		THXL		100k		
	Thermal Mag	TJM	70, 90...225	65k	25k	0.5
		TJX		100k		
LSI	TJML	100, 150	65k	35k		
	TJXL		100k			
400 A D	LSI	TKM	300, 400	65k	25k	2.0
		TKX		100k		
		TKU		—		
800 A E	LSI	TMM	600	65k	25k	2.0
		TMX		100k	42k	
	LSIG	TMMG		65k	25k	
		TMXG		100k	42k	
800 A F	LSI	TMM	800	65k	25k	2.5
		TMX		100k	42k	
	LSIG	TMMG		65k	25k	
		TMXG		100k	42k	
	HI-MAG	TMN		65k	—	
1200 A G	LSI	TNM	400, 600, 800, 1000, 1200	65k	25k	3.5
		LSIG				
	LSI	TNX		100k	65k	
		LSIG				
	HI-MAG	TNN		1200	65k	
3000 A J	LSIG	TRUG	1000, 1200, 1600, 2000	100k	100k	6.0 x 30 in. W x 15 in. D
3000 A K	LSIG		2500			6.0 x 30 in. W x 15 in. D
3000 A L	LSIG		3000			6.0 x 30 in. W x 20 in. D

(1) Adding options can increase the space factor of the unit.

Bulletin 2193M 3-Pole Main Circuit Breaker (MCB)

Frame			Range of Available Trips (A)	Short-circuit Current Ratings (rms symmetrical A)		Space Factor ⁽¹⁾
Rating (A)	Trip Style	Type		480V	600V	
125 A A	Thermal Mag	TGM	15...125	65k	—	1.5
125 A B	Thermal Mag	THM	15...125	65k	—	
		THX		100k	35k	
250 A C	Thermal Mag	TJM	70, 90...225	65k	—	
		TJX		100k	35k	
	LSI	TJML	40, 60, 100, 150, 250	65k	—	
		TJXL		100k	35k	
400 A D	LSI	TKM	300, 400	65k	—	2.0
		TKX		100k	65k	
		TKU		—	100k	
800 A E	LSI	TMM	600	65k	—	
		TMX		100k	42k	
	LSIG	TMMG		65k	—	
		TMXG		100k	42k	
800 A F	LSI	TMM	800	65k	—	2.5
		TMX		100k	42k	
	LSIG	TMMG		65k	—	
		TMXG		100k	42k	
	HI-MAG	TMN		65k	—	
1200 A G	LSI	TNM	400, 600, 800, 1000, 1200	65k	—	3.5
	LSIG	TNMG		100k	65k	
	LSI	TNX				
	LSIG	TNXG				
	HI-MAG	TNN	1200	65k	—	
3000 A J	LSIG	TRUG	1000, 1200, 1600, 2000	100k	100k	6.0 x 30 in. W x 15 in. D
3000 A K	LSIG		2500			6.0 x 30 in. W x 20 in. D
3000 A L	LSIG		3000			6.0 x 35 in. W x 20 in. D

(1) Adding options can increase the space factor of the unit.

Lighting and Power Panel Units

Lighting Panel (LPAN) - Bulletin 2193LE

Bulletin 2193LE is a frame mounted lighting panel with either a main lug or main circuit breaker. The lighting panels are rated for 100 A or 225 A with up to 42 branch circuits. One, two and three pole bolt-on branch circuit breakers are available with ratings from 15...100 A.

Bulletin 2193LE Frame Mounted Lighting Panel for Bolt-on Branch Circuit Breakers (LPAN)

Type	Panel Bus and Main Lug Ampere Rating	Max. Number of 1-pole Circuit Breakers	Space Factor ⁽¹⁾
Single Phase 3-Wire 120/240V AC 10 kA IC rms Sym. ⁽²⁾	100	18	2.0
	225	30	2.5
		42	3.0
Three Phase 4-Wire 120/208V AC 10 kA IC rms Sym. ⁽²⁾	100	18	2.0
		30	2.5
	225	42	3.0
Single Phase 3-Wire 120/240V AC ⁽³⁾	100	16	2.0
	225	30	3.5
		42	4.0
Three Phase 4-Wire 120/208V AC ⁽³⁾	100	15	2.0
		27	2.5
	225	42	4.0

(1) Adding options can increase the space factor of the unit.

(2) With Main Lug Only (MLO).

(3) With Main Circuit Breaker (MCB) 100 A Main Circuit Breaker is Cutler-Hammer BAB type series rating 10 kA. 225 A Main Circuit Breaker is Cutler-Hammer ED type series rating 65kA.

Panel Board with Main Circuit Breaker (PPAN) - Bulletin 2193PP

Bulletin 2193PP is a plug-in unit panel board with a main circuit breaker. The panel boards are rated for 100 A, 150 A, or 225 A with up to 42 branch circuits. One, two and three pole bolt-on branch circuit breakers are available with ratings from 15...100 A. The Bulletin 2193PP panel board is suitable for use with 3-phase, 4-wire, solidly grounded, Wye systems rated 480Y/277V or less. It can also be used on solidly grounded 3-wire power systems, however, only 2-pole and 3-pole branch circuit breakers can be used.

Bulletin 2193PP Plug-in Panel Board with Main Circuit Breaker (PPAN)

Main Breaker Trip Rating [A]	Max. Number of 1-pole Circuit Breakers	Main Circuit Breaker Type	Space Factor ⁽¹⁾	IC Rating at 480Y/277V [rms Sym.] ⁽²⁾
100	18	I3C	2.5	25 kA
		I6C		65 kA
		I0C		100 kA
150	30	I3C	3.0	25 kA
		I6C		65 kA
		I0C		100 kA
	42	3.5	I3C	25 kA
			I6C	65 kA
			I0C	100 kA
225	18	JD3D	3.5	35 kA ⁽³⁾
	30			
	42			

(1) Adding options can increase the space factor of the unit.

(2) This rating can be applied to all branch circuit breakers.

(3) 35 kA series combination rating only when used with 50 A or lower rated branch circuit breakers. Series combination rating is 22 kA when used with branch circuit breakers rated 60 A or higher.

Transformer Units

This section provides information about these transformer units.

- Control and Lighting Transformers without Disconnecting Means (XFMR) - Bulletin 2195
- Control and Lighting Transformers with Fusible Disconnect Switch (XFMR) - Bulletin 2196
- Control and Lighting Transformers with Circuit Breaker (XFMR) - Bulletin 2197

The transformer units are available with ratings from 0.5...50 kVA for single-phase and 10...45 kVA for three-phase. Secondary fuses are provided with each transformer unit. Factory installed primary fusing is optional on the Bulletin 2196 transformer unit.

Control and Lighting Transformer Unit (XFMR)

Rating kVA ⁽¹⁾	Recommended Primary Protection (A)			Bulletin 2195 Space Factor ⁽²⁾	Bulletin 2196 Space Factor ⁽²⁾	Bulletin 2196Z Space Factor ⁽²⁾	Bulletin 2197 Space Factor ⁽²⁾	Bulletin 2197Z Space Factor ⁽²⁾			
	240V	480V	600V								
SINGLE PHASE—120 Volt secondary with one secondary fuse											
0.5	15 ⁽³⁾	15 ⁽³⁾	15 ⁽³⁾	1.0	1.0	—	1.0	—			
0.75				1.5	1.5		1.5				
1				2.0	2.0		2.0				
1.6				1.5	2.5	2.0	2.5		2.0		
2				—	—	—	—		—	—	—
3 (1.5)				—	—	—	—		—	—	—
5 (2.5)	—	—	—	—	—	—	—	—			
SINGLE PHASE—120/240 Volt secondary with two secondary fuses. Transformer secondary wired and protected for 240V phase to phase/120V phase to center tap neutral.											
5 (2.5)	30	15 ⁽³⁾	—	1.5	2.5	2.0	2.5	2.0			
7.5 (3.7)	40 ⁽⁴⁾	20 ⁽³⁾	20 ⁽³⁾								
10 (5)	50 ⁽⁴⁾	30	20 ⁽³⁾								
15 (7.5)	70	40 ⁽⁵⁾	30 ⁽⁵⁾	2.0	3.0	—	3.0	2.5			
25 (12.5)	125	70 ⁽⁵⁾	60								
37.5 (18.5)	200	100	70 ⁽⁶⁾	2.0, 20" D	3.5, 20" D	—	3.0, 20" D	2.5, 20" D			
50 (25)	300 ⁽⁷⁾	150 ⁽⁸⁾	100								
THREE PHASE—120/208 Volt secondary with three secondary fuses. Transformer secondary wired and protected for 208V phase to phase/120V phase to WYE neutral.											
10 (5)	—	20 ⁽³⁾	15 ⁽³⁾	2.0	3.0	2.5	3.0	2.5			
15 (7.5)	—	20 ⁽³⁾	15 ⁽³⁾⁽⁹⁾								
25 (12.5)	—	40 ⁽⁵⁾	30 ⁽⁵⁾								
30 (15)	—	50 ⁽⁵⁾	40 ⁽⁵⁾								
37.5 (18.5)	—	60	50 ⁽⁵⁾	2.0, 20" D	3.0, 20" D	—	3.0, 20" D	2.5, 20" D			
45 (22.5)	—	70	60								
SINGLE PHASE—110/115 Volt secondary with one 1-pole circuit breaker											
0.5	15 ⁽³⁾	15 ⁽³⁾	15 ⁽³⁾	1.0	1.0	—	1.0	—			
0.75				1.5	1.5		1.5				
1				2.0	2.0		2.0				
1.6				1.5	2.5	2.0	2.5		2.0		
2				—	—	—	—		—	—	—
3 (1.5)				—	—	—	—		—	—	—
SINGLE PHASE—110/220 Volt secondary with two 1-pole circuit breakers. Transformer secondary wired and protected for 220V phase-to-phase, 110V phase-to-center tap neutral.											
5 (2.5)	20 ⁽³⁾	—	—	1.5	2.5	2.0	2.5	2.0			
7.5 (3.7)	20 ⁽³⁾	—	—								
10 (5)	30 ⁽³⁾	—	—								
15 (7.5)	50 ⁽⁵⁾	—	—						2.0	3.0	—

Control and Lighting Transformer Unit (XFMR) (Continued)

Rating kVA ⁽¹⁾	Recommended Primary Protection (A)			Bulletin 2195 Space Factor ⁽²⁾	Bulletin 2196 Space Factor ⁽²⁾	Bulletin 2196Z Space Factor ⁽²⁾	Bulletin 2197 Space Factor ⁽²⁾	Bulletin 2197Z Space Factor ⁽²⁾
	240V	480V	600V					
SINGLE PHASE—115/230 Volt secondary with two 1-pole circuit breakers Transformer secondary wired and protected for 230V phase-to-phase, 115V phase-to-center tap neutral.								
5 (2.5)	—	20 ⁽³⁾	—	1.5	2.5	2.0	2.5	2.0
7.5 (3.7)	—	20 ⁽³⁾	—					
10 (5)	—	30	—					
SINGLE PHASE—120/240 Volt secondary with two 1-pole circuit breakers Transformer secondary wired and protected for 240V phase-to-phase, 120V phase-to-center tap neutral.								
5 (2.5)	—	—	20 ⁽³⁾	1.5	2.5	2.0	2.5	2.0
7.5 (3.7)	—	—	20 ⁽³⁾					
10 (5)	—	—	30					
15 (7.5)	—	—	50 ⁽⁵⁾	2.0	3.0	—	3.0	2.5

- (1) In NEMA/UL Type 12 applications (non-ventilated 3 kVA and larger transformers), to maximize the transformer life, we recommend that the transformer not be loaded to greater than 50% of its nameplate rating. Number in parentheses indicates approximate derated rating. However, in many applications, NEMA/UL Type 1 with gasket design (vented and filtered doors) can be sufficient.
- (2) Adding options can increase the space factor of the unit.
- (3) 30 A fuse clip rating for Bulletin 2196 and 2196Z.
- (4) 60 A fuse clip rating for Bulletin 2196 not available for Bulletin 2196Z.
- (5) 60 A fuse clip rating for Bulletin 2196.
- (6) 100 A fuse clip rating for Bulletin 2196.
- (7) Not available for Bulletin 2196, 2197, and 2197Z.
- (8) 200 A fuse clip rating for Bulletin 2196.
- (9) 20 A circuit breaker rating for Bulletin 2197 and 2197Z.

Miscellaneous Units

Full section blank mounting plates are six space factors in size. They are available with no disconnect means, fusible disconnect switch or circuit breaker. They are also available with or without the horizontal bus.

Blank unit doors are available in a range of space factors from 0.5...4.0 in 0.5 space factor increments. The blank unit doors cover the unused unit space and have a unit support pan.

Empty Unit Inserts

Description	Space Factor ⁽¹⁾
Empty Unit Insert	0.5...4.0 (in 0.5 space factor increments)
Empty Unit Insert with Disconnecting Means	1.5...4.0 (in 0.5 space factor increments)
	1.5...4.0 (in 0.5 space factor increments)

- (1) Adding options can increase the space factor of the unit.

DeviceNet Network Units and EtherNet/IP Network Units

Description	Space Factor ⁽¹⁾	
DeviceNet Power Supply Unit (110...120V AC input and 8.0 A, 24V DC output)	Without disconnection means, plug-in stabs or control circuit transformer. Requires separate 110...120V AC source.	0.5
	Includes disconnect, fuses and 350VA control circuit transformer to provide power to power supply.	1.0
	Includes circuit breaker, fuses and 350VA control circuit transformer to provide power to power supply.	
Redundant DeviceNet Power Supply Unit (110...120V AC input and 8.0 A, 24V DC output)	Without disconnection means, plug-in stabs or control circuit transformer. Requires separate 110...120V AC source.	1.0
	Includes disconnect, fuses and 750VA control circuit transformer to provide power to power supply.	1.5
	Includes circuit breaker, fuses and 750VA control circuit transformer to provide power to power supply.	

DeviceNet Network Units and EtherNet/IP Network Units (Continued)

Description		Space Factor ⁽¹⁾
Ethernet Power Supply Unit (110...120V AC input and 10 A 24V DC output).	Without disconnection means, plug-in stabs, or control circuit transformer. Requires separate 110...120V AC source.	0.5
	Includes disconnect, fuses, and control circuit transformer to provide power to power supply.	1.0
	Includes circuit breaker, fuses, and control circuit transformer to provide power to power supply.	1.0
Redundant Ethernet Power Supply Unit (110...120V AC input and 10 A, 24V DC output).	Without disconnection means, plug-in stabs, or control circuit transformer. Requires separate 110...120V AC source.	1.0
	Includes disconnect, fuses, and control circuit transformer to provide power to power supply.	1.5
	Includes circuit breaker, fuses, and control circuit transformer to provide power to power supply.	1.5
ControlNet to DeviceNet linking device (Bulletin 1788)	Without disconnecting means, plug-in stabs, or control circuit transformer. Requires separate 110...120V AC source. Viewing window in door to provide visual verification of network status.	0.5
	With disconnect, fuses, and 80VA control circuit transformer. Viewing window in door to provide visual verification of network status.	1.0
	With circuit breaker, fuses, and 80VA control circuit transformer. Viewing window in door to provide visual verification of network status.	
Ethernet to DeviceNet linking device (Bulletin 1788)	Without disconnecting means, plug-in stabs or control transformer. Requires separate 110...120V AC source. Viewing window in door to provide visual verification of network status.	0.5
	With fusible disconnect and 80VA control transformer. Viewing window in door to provide visual verification of network status.	1.0
	With circuit breaker and 80VA control transformer. Viewing window in door to provide visual verification of network status.	
External DeviceNet Connector Unit with remotely powered 120V AC receptacle	Door mounted external DeviceNet connection and 120V AC receptacle for connection of computer to DeviceNet without having to open doors.	0.5

(1) Adding options can increase the space factor of the unit.

Miscellaneous Units

Description		Space Factor ⁽¹⁾		
NEMA Type 'C' Terminal Board Unit (supplied unwired)	Includes Bulletin 1492-CA1 terminal blocks	Top or bottom-mounted	44 Terminal Blocks	1.0
			66 Terminal Blocks	
			88 Terminal Blocks	
			110 Terminal Blocks	
	Top or bottom-mounted	76 Terminal Blocks	1.5	
		114 Terminal Blocks		
		152 Terminal Blocks		
	190 Terminal Blocks			
Neutral Connection Plate Unit	0.25 in. x 2 in. x 12 in. copper tin plated bus plate with #6-250 kcmil lug (280 A capacity)	0.5		
	0.25 in. x 2 in. x 12 in. copper silver plated bus plate with #6-250 kcmil lug (280 A capacity)	0.5		
Surge Protective Device Unit (formerly known as TVSS)	WYE power systems with a solidly grounded neutral 3-wire	480V L-L, 277V L-G	0.5	
		600V L-L, 346V L-G		
		208V L-L, 120V L-G		
		380V L-L, 220V L-G		
		400V L-L, 230V L-G		
		415V L-L, 240V L-G		
	WYE power systems with a solidly grounded neutral, 4-wire	480V L-L, 277V L-G, 277V L-N		
	WYE power systems with impedance grounded neutral or 3 Phase, 3-Wire Delta Power Systems	480V		
		600V		
240V				
380V				
400V				
415V				
Corner Section	Inside corner configuration is either 15 in. deep by 25 in. wide or 20 in. deep by 30 in. wide and is designed to contain power bus rated 600...2000 A only. There is no available space for the installation of units. The corner section does not have vertical wireway. Not available in either NEMA/UL Type 3R, Type 4 or back-to-back construction.	6.0		

Step 6: Select Unit Types

(1) Adding options can increase the space factor of the unit.

Control Circuit Transformer (with grounded and fused secondary)

Description	Size or Rating	FVC	Size or Rating	FVR	FVNR	TS1W TS2W
		2102L, 2103L		2106, 2107	2112, 2113	2122, 2123
		VA		VA	VA	VA
Standard capacity with primary fusing	30 A	80	1	80	80	80
	60 A	80	2	80	80	80
	100 A	200	3	200	200	200
	200 A	250	4	250	250	250
	300 A	350	5	350	350	350
	—	—	6	—	80	—
	—	—	200 A and 400 A	—	250	—
	—	—	600 A	—	500	—
100 watt extra capacity with primary fusing	30 A	130	1	130	130	130
	60 A	130	2	130	130	130
	100 A	250	3	250	250	250
	200 A	350	4	350	350	350
	300 A	500	5	500	500	500
	—	—	6	—	130	—
	—	—	200 A and 400 A	—	350	—
	—	—	600 A	—	750	—

Electronic Overload Relays

Option	Description	FVR	FVNR	2193M, 2193F
		2106, 2107	2112, 2113	
E300 Electronic Overload Relay	Communication Based Overload	✓	✓	✓
E100 Electronic Overload Relay	Basic-tier electronic overload relay	✓	✓	—

EtherNet/IP Switch Units

Switch Type	Description
Stratix Ethernet Switch 10-Port	Mounted in the Top Horizontal Wireway. It is used in the Top Horizontal Wireway for Ethernet IntelliCENTER sections that do not have a 6.0 SF frame mount unit.
Stratix Ethernet Switch 10-Port Main	Mounted in the Top Horizontal Wireway. This unit is used in a pluggable section next to a top incoming main for Ethernet IntelliCENTER. This unit holds a total of 2 switches: Switch for the section it which it resides. Switch for the section with the top incoming main or top frame mounted unit.

Soft Starter Units

These combination soft starter units contain a microprocessor-controlled motor controller, control circuit transformer and either a fusible disconnect switch or circuit breaker.

Specify a soft starter rather than a variable frequency drive when the following is required:

- A cost effective starter
- No speed control
- Simple acceleration and deceleration
- Lower starting torque
- Generously sized motor for the load
- Standard starting and stopping maneuvers
- Dynamic braking is not required
- The starter is not used to hold the rotor in place at zero speed

For additional information regarding soft starters, see the SMC-3, SMC Flex, and SMC-50 Smart Motor Controllers Technical data, publication [150-TD009](#).

For SMC-3 soft starter unit selection, go to [page 46](#).

SMC-3 Soft Starter Units - Bulletin 2154H and 2155H Features

- Three starting modes: soft start, kick start and current limit
- Electronic overload protection with selectable overload trip class
- Motor and system diagnostics
- Configurable auxiliary contacts
- Soft stop
- Integrated bypass contactor

SMC Flex Soft Starter Units - Bulletin 2154J and 2155J Features

- Seven standard modes of operation: soft start, current limit start, dual ramp, full voltage, linear speed acceleration, preset slow speed and soft stop
- Optional modes of operation: pump control, Smart Motor Braking, Accu-Stop™, and slow speed with braking
- Integral SCR bypass
- Electronic overload protection with selectable trip class
- Full metering and diagnostics
- Four programmable auxiliary contacts
- DPI communication
- LCD display
- Keyboard programming

For SMC Flex soft starter unit selection, go to [page 46](#).

Soft Starter Unit Selection

Bulletin 2154H Combination Soft Starter Motor Controller with Fusible Disconnect Switch (SMC-3)

Rating (A)	Nominal Horsepower (Nominal kW) ⁽¹⁾					Disconnect Rating	NEMA/UL Type 1 and Type 1 with gasket	NEMA/UL Type 12
	220...230V	240V	380...415V	480V	600V		Space Factor ⁽²⁾	Space Factor ⁽²⁾
3	(0.25...0.55)	0.5	(0.37...1.1)	0.5...1.5	0.75...2	30	0.5	0.5
9	(0.75...2.2)	0.75...2	(1.5...3.7)	2...5	3...7.5	30	0.5	0.5
19	(3.7)	3...5	(5.5...7.5)	7.5...10	10...15	30	0.5	0.5
25	(5.5)	7.5	(11)	15	20	30	1.0	1.0
30	(7.5)	10	(15)	20	25	60	1.0	1.0
37	—	—	(18.5)	25	30	60	1.0	1.0
43	(11)	15	(22)	30	40	60	1.5	2.0
60	(15)	20	(30)	40	50	100	1.5	2.5
85	(18.5...22)	25...30	(37)	50	—	100		
	—	—	(45)	60	60...75	200		
108	(30)	40	(55)	75	100	200	3.5	4.0
135	(37)	50	—	100	125	200	4.5	6.0, 20" W

(1) The horsepower and kW ratings shown are nominal. The limiting factor in the application and use of the SMC-3 is the output ampere rating.

(2) Adding options can increase the space factor of the unit.

Bulletin 2155H Combination Soft Starter Motor Controller with Circuit Breaker (SMC-3)

Rating (A)	Nominal Horsepower (Nominal kW) ⁽¹⁾					Disconnect Rating	NEMA/UL Type 1 and Type 1 with gasket	NEMA/UL Type 12
	220...230V	240V	380...415V	480V	600V		Space Factor ⁽²⁾	Space Factor ⁽²⁾
3	(0.25...0.55)	0.5	(0.37...1.1)	0.5...1.5	0.75...2	1.0	1.0	
9	(0.75...2.2)	0.75...2	(1.5...3.7)	2...5	3...7.5			
19	(3.7)	3...5	(5.5...7.5)	7.5...10	10...15			
25	(5.5)	7.5	(11)	15	20			
30	(7.5)	10	(15)	20	25			
37	—	—	(18.5)	25	30			
43	(11)	15	(22)	30	40			
60	(15)	20	(30)	40	50	1.5	2.0	
	—	—	(45)	60	60...75		2.5	
85	(18.5...22)	25...30	(37)	50	—	2.5	3.0	
	—	—	(45)	60	60...75		3.0	
108	(30)	40	(55)	75	100	2.5	3.5	
135	(37)	50	—	100	—	2.5		
135	—	—	—	—	125	3.0		

(1) The horsepower and kW ratings shown are nominal. The limiting factor in the application and use of the SMC-3 is the output ampere rating.

(2) Adding options can increase the space factor of the unit.

Bulletin 2154J - SMC Flex Soft Starter Motor Controller with Fusible Disconnect Switch - Line Connected

Rating (A)	Nominal Horsepower (Nominal kW) ⁽¹⁾					Disconnect Rating	NEMA/UL Type 1 and Type 1 w/ gasket	NEMA/UL Type 12
	220...230V	240V	380...415V	480V	600V		Space Factor ⁽²⁾	Space Factor ⁽²⁾
5	(0.25...1.1)	0.5...1	(0.37...2.2)	0.5...3	0.75...3	30	2.0	3.0
25	(1.5...5.5)	1.5...7.5	(3.7...11)	5...15	5...20	30		
43	(7.5...11)	10...15	(15...22)	20...30	25...40	60		
60	(15)	20	(30)	40	50	100	2.5	3.5
85	(18.5...22)	25...30	(37)	50	—	100		
	—	—	(45)	60	60...75	200		
108	(30)	40	(55)	75	100	200	3.5	4.0
135	(37)	50	—	100	125	200	4.5	6.0, 20" W

Bulletin 2154J - SMC Flex Soft Starter Motor Controller with Fusible Disconnect Switch - Line Connected (Continued)

Rating (A)	Nominal Horsepower (Nominal kW) ⁽¹⁾					Disconnect Rating	NEMA/UL Type 1 and Type 1 w/ gasket	NEMA/UL Type 12
	220...230V	240V	380...415V	480V	600V		Space Factor ⁽²⁾	Space Factor ⁽²⁾
201	(45...55)	60...75	(75...90)	125...150	150...200	400	6.0, 20"W	6.0, 20" W
251	(75)	100	(110...132)	200	250	400		
317	(90)	125	(150...160)	250	300	400	6.0, 20"W, 20" D	6.0, 20" W, 20" D
361	(110)	150	(185)	300	350	600		
480	(132)	200	(200...250)	350...400	400...500	600		

(1) The horsepower and kW ratings shown are nominal. The limiting factor in the application and use of the SMC Flex is the output ampere rating.

(2) Adding options can increase the space factor of the unit.

Bulletin 2155J - SMC Flex Soft Starter Motor Controller with Circuit Breaker - Line Connected

Rating (A)	Nominal Horsepower (Nominal kW) ⁽¹⁾					NEMA/UL Type 1 and Type 1 w/ gasket	NEMA/UL Type 12
	220...230V	240V	380...415V	480V	600V		
5	(0.25...1.1)	0.5...1	(0.37...2.2)	0.5...3	0.75...3	2.0	3.0
25	(1.5...5.5)	1.5...7.5	(3.7...11)	5...15	5...20		
43	(7.5...11)	10...15	(15...22)	20...30	25...40		
60	(15)	20	(30)	40	50		
85	(18.5...22)	25...30	(37)	50...60	60...75	2.5	3.0
	—	—	(45)	—	—		
108	(30)	40	(55)	75	100	6.0, 20"W	6.0, 20"W
135	(37)	50	—	100	125		
201	(45...55)	60...75	(75...90)	125...150	150...200	6.0 20"W, 20" D	6.0 20"W, 20" D
251	(75)	100	(110...132)	200	250		
317	(90)	125	(150...160)	250	300		
361	(110)	150	(185)	300	350	6.0 20"W, 20" D	6.0 20"W, 20" D
480	(132)	200	(200...250)	350...400	400...500		

(1) The horsepower and kW ratings shown are nominal. The limiting factor in the application and use of the SMC Flex is the output ampere rating.

(2) Adding options can increase the space factor of the unit.

Variable Frequency Drive Units

The combination variable frequency AC motor drive units contain a high performance, microprocessor-controlled, variable frequency AC drive and either a fusible disconnect switch or a circuit breaker.

They also:

- Include isolated logic and power.
- Include fans and venting where required.
- Include internal electronic overload protection.
- Include EMC filters on 380...415V AC.
- Include UL Class CC or J time delay fuses. These fuses provide both branch circuit protection and drive input protection. The drive input fuses are provided in series with the circuit breaker in some drive units.
- Include control circuit transformer (CCT). The CCT is sized to provide power for all standard pilot devices and any required fans.
- Produce a three-phase, pulse width modulated (PWM) adjustable frequency output and voltage output for exceptional control of motor speed and torque.
- Are digitally programmable with access to mode programming, providing precise and repeatedly accurate setup, control and operation and adaptability to handle a variety of applications.
- Have available 24V DC or 115V AC control voltages on some units.
- The Integrated Safe Torque Off safety option card provides Safe Torque Off functionality with the built-in EtherNet/IP port of the PowerFlex 755 family of drives. The option module removes rotational power to the motor without loss of power to the drive. It integrates with GuardLogix[®] controllers and requires Studio 5000 version 30 and higher.

Step 6: Select Unit Types

You need to select a Human Interface Module (HIM) and Control Platform Type for the drive units.

Select the drive unit based on nominal load Hp (kW) size. If full load current exceeds output current, select the unit based on the next larger Hp (kW).

Drives listed as Normal Duty have output current overload capabilities of 110% for 60 seconds and 150% for 3 seconds. Drives listed as Heavy Duty have output current overload capabilities of 150% for 60 seconds and 200% for 3 seconds.

Each unit is provided as a NEMA Wiring Class I, Type A unit with terminals mounted on the drive chassis for connection of remote pilot devices and input signals.

For NEMA/UL Type 3R and NEMA/UL Type 4 enclosure construction, contact your local Rockwell Automation sales office or Allen-Bradley distributor.

Proper placement of drive units in the MCC is essential for proper operation and life cycle of the drive. Strong consideration should be given to placing units with drives at the bottom of the section. When more than one drive unit is placed in a section, the drive unit with the highest rating should be located at the bottom of the section.

Do not mount transformer units below drive units. Heat from the transformer units can cause the drive to trip.

For additional information regarding variable frequency drives refer to the PowerFlex Low Voltage Drives Selection Guide, publication [PFLEX-SG002](#).

PowerFlex 70 AC Drive

These combination variable frequency AC motor drive units are specifically designed for use in CENTERLINE motor control centers. Each unit contains a high performance, microprocessor-controlled, variable frequency AC drive and either a fusible disconnect switch or a circuit breaker.

Bulletin 2162Q PowerFlex 70 Variable Frequency AC Drive (VFD) Units with Fusible Disconnect, Normal Duty

Nominal Load Hp (kW)	380V, 400V, and 415V			480V			600V		
	Maximum Continuous Output Current (A)	Space Factor ⁽¹⁾		Maximum Continuous Output Current (A)	Space Factor ⁽¹⁾		Maximum Continuous Output Current (A)	Space Factor ⁽¹⁾	
		NEMA/UL Type 1 and 1 w/Gasket	NEMA/UL Type 12		NEMA/UL Type 1 and 1 w/Gasket	NEMA/UL Type 12		NEMA/UL Type 1 and 1 w/Gasket	NEMA/UL Type 12
0.5 (0.37)	1.3	1.5	2.0	1.1	1.5	2.0	0.9	1.5	2.0
0.75 (0.55)	1.5			1.6			1.3		
1.0 (0.75)	2.1			2.1			1.7		
1.5 (1.1)	2.6			3			2.4		
2 (1.5)	3.5			3.4			2.7		
3 (2.2)	5			5			3.9		
5 (3.7)	8.7	2.5	8	2.5	6.1	2.5	2.5		
7.5 (5.5)	11.5	2.0	3.0	11	2.0	3.0	9	2.0	3.0
10 (7.5)	15.4			14			11		
15 (11)	22			22			17		
20 (15)	30	2.5	3.5	27	2.5	3.5	22	2.5	3.5
25 (18.5)	37			34			27		
30 (22)	43	3.0	3.5	40	3.0	3.5	32	3.0	3.5
40 (30)	60			52			41		
50 (37)	72			65			52		

(1) Adding options can increase the space factor of the unit.

Bulletin 2162Q PowerFlex 70 Variable Frequency AC Drive (VFD) Units with Fusible Disconnect, Heavy Duty

Nominal Load Hp (kW)	480V			600V		
	Maximum Continuous Output Current (A)	Space Factor ⁽¹⁾		Maximum Continuous Output Current (A)	Space Factor ⁽¹⁾	
		NEMA/UL Type 1 and 1 w/Gasket	NEMA/UL Type 12		NEMA/UL Type 1 and 1 w/Gasket	NEMA/UL Type 12
0.5 (0.37)	1.1	1.5	2.0	0.9	1.5	2.0
0.75 (0.55)	1.6			1.3		
1.0 (0.75)	2.1			1.7		
1.5 (1.1)	3.0			2.4		
2 (1.5)	3.4			2.7		
3 (2.2)	5.0	2.5	2.5	3.9	2.0	3.0
5 (3.7)	8.0	2.0	3.0	6.1		
7.5 (5.5)	11			9.0		
10 (7.5)	14	2.5	3.0	11	2.5	3.0
15 (11)	22			17		
20 (15)	27			3.5		
25 (18.5)	34	3.0	3.5	27	3.0	4.0
30 (22)	40	3.0	4.0	32		
40 (30)	52	3.5	4.0	41		

(1) Adding options can increase the space factor of the unit.

Bulletin 2163Q PowerFlex 70 Variable Frequency AC Drive (VFD) Units with Circuit Breaker Disconnect, Normal Duty

Nominal Load Hp (kW)	380V, 400V, and 415V			480V			600V		
	Maximum Continuous Output Current (A)	Space Factor ⁽¹⁾		Maximum Continuous Output Current (A)	Space Factor ⁽¹⁾		Maximum Continuous Output Current (A)	Space Factor ⁽¹⁾	
		NEMA/UL Type 1 and 1 w/Gasket	NEMA/UL Type 12		NEMA/UL Type 1 and 1 w/Gasket	NEMA/UL Type 12		NEMA/UL Type 1 and 1 w/Gasket	NEMA/UL Type 12
0.5 (0.37)	1.3	1.5	2.0	1.1	1.5	2.0	0.9	1.5	2.0
0.75 (0.55)	1.5			1.6					
1.0 (0.75)	2.1			2.1					
1.5 (1.1)	2.6			3.0					
2 (1.5)	3.5			3.4					
3 (2.2)	5.0	5.0	2.5	6.1	2.0	3.0			
5 (3.7)	8.7	2.5	8.0	9.0					
7.5 (5.5)	11.5	2.0	3.0	11			11		
10 (7.5)	15.4			14	17				
15 (11)	22	2.5	3.5	22	2.5	3.5	2.5	3.0	
20 (15)	30			3.5					27
25 (18.5)	37			3.0					34
30 (22)	43	3.0	3.5	40	3.0	3.5	32	3.0	4.0
40 (30)	60	3.0	4.0	52	3.0	4.0	41		
50 (37)	72	4.0	4.0	65	3.5	4.0	52		

(1) Adding options can increase the space factor of the unit.

Bulletin 2163Q PowerFlex 70 Variable Frequency AC Drive (VFD) Units with Circuit Breaker Disconnect, Heavy Duty

Nominal Load Hp (kW)	480V			600V		
	Maximum Continuous Output Current (A)	Space Factor ⁽¹⁾		Maximum Continuous Output Current (A)	Space Factor ⁽¹⁾	
		NEMA/UL Type 1 and 1 w/Gasket	NEMA/UL Type 12		NEMA/UL Type 1 and 1 w/Gasket	NEMA/UL Type 12
0.5 (0.37)	1.1	1.5	2.0	0.9	1.5	2.0
0.75 (0.55)	1.6			1.3		
1.0 (0.75)	2.1			1.7		
1.5 (1.1)	3.0			2.4		
2 (1.5)	3.4			2.7		
3 (2.2)	5	2.5	3.9	6.1	2.0	2.5
5 (3.7)	8	2.0	3.0			
7.5 (5.5)	11			9.0		
10 (7.5)	14			11		
15 (11)	22	2.5	3.5	17	2.5	3.5
20 (15)	27		3.0			
25 (18.5)	34	3.0	3.5	27	2.5	3.0
30 (22)	40	3.0	4.0	32		
40 (30)	52	3.5	4.0	41		

(1) Adding options can increase the space factor of the unit.

PowerFlex 753 and PowerFlex 755 AC Drive

These combination variable frequency AC motor drive units are specifically designed for use in CENTERLINE motor control centers. Each unit contains a high performance, microprocessor-controlled, variable frequency AC drive and either a fusible disconnect switch or a circuit breaker.

Bulletin 2162U, 2162V PowerFlex 753 and PowerFlex 755 Variable Frequency AC Drive (VFD) with Fusible Disconnect, Normal Duty

Nominal Hp (kW)	480V			600V				
	Maximum Continuous Output Current (A)	Space Factor ⁽¹⁾		Maximum Continuous Output Current (A)	Space Factor ⁽¹⁾			
		NEMA/UL Type 1 and Type 1 w/Gasket	NEMA/UL Type 12		NEMA/UL Type 1 and Type 1 w/Gasket	NEMA/UL Type 12		
0.5	N/A			0.9	2.5			
0.75	N/A			1.3				
1	2.1	2.0		1.7				
1.5	3			2.4				
2	3.4			2.7				
3	5			3.9				
5	8			6.1				
7.5	11			9				
10	14	2.5		11			3.0	
15	22	3.0		17				
20	27	3.5		22				
25	34	3.0		27	4.0			
30	40			3.5			32	
40	52	4.0		41	6.0 x 20 in. W x 15 in. D	6.0 x 25 in. W x 15 in. D		
50	65	3.5		52	6.0 x 25 in. W x 15 in. D			
60	77	6.0 x 20 in. W x 15 in. D	6.0 x 25 in. W x 15 in. D	63	6.0 x 25 in. W x 20 in. D			
75	96	6.0 x 25 in. W x 15 in. D	6.0 x 25 in. W x 15 in. D	77				
100	125	6.0 x 25 in. W x 20 in. D		99			6.0 x 30 in. W x 20 in. D	
125	156			6.0 x 30 in. W x 20 in. D				
150	186	6.0 x 35 in. W x 20 in. D		144	6.0 x 30 in. W x 20 in. D	N/A		
200	248	6.0 x 30 in. W x 20 in. D	N/A					
250	302	6.0 x 35 in. W x 20 in. D		N/A				
300	361			N/A				

(1) Adding options can increase the space factor of the unit.

Bulletin 2162U, 2162V PowerFlex 753 and PowerFlex 755 Variable Frequency AC Drive (VFD) with Fusible Disconnect, Heavy Duty

Nominal Hp (kW)	480V			600V			
	Maximum Continuous Output Current (A)	Space Factor ⁽¹⁾		Maximum Continuous Output Current (A)	Space Factor ⁽¹⁾		
		NEMA/UL Type 1 and Type 1 w/Gasket	NEMA/UL Type 12		NEMA/UL Type 1 and Type 1 w/Gasket	NEMA/UL Type 12	
0.5	N/A			0.9	2.5		
0.75	N/A			1.3			
1	2.1	2.0	2.5	1.7			
1.5	3			2.4			
2	3.4			2.7			
3	5			3.9			
5	8			6.1			
7.5	11			9			
10	14	3.0	11	3.0			
15	22	3.5	17				
20	27	3.0	4.0	22	6.0 x 20 in. W x 15 in. D	6.0 x 25 in. W x 15 in. D	
25	34			27			
30	40			32	6.0 x 25 in. W x 15 in. D	6.0 x 25 in. W x 20 in. D	6.0 x 25 in. W x 20 in. D
40	52			41	6.0 x 30 in. W x 20 in. D		
50	65	6.0 x 20 in. W x 15 in. D	6.0 x 25 in. W x 15 in. D	52	6.0 x 25 in. W x 20 in. D	6.0 x 25 in. W x 20 in. D	
60	77	6.0 x 25 in. W x 15 in. D	6.0 x 30 in. W x 20 in. D	63		6.0 x 30 in. W x 20 in. D	
75	96	6.0 x 25 in. W x 20 in. D	6.0 x 35 in. W x 20 in. D	77	6.0 x 30 in. W x 20 in. D	6.0 x 30 in. W x 20 in. D	
100	125			99		6.0 x 35 in. W x 20 in. D	
125	156			125		6.0 x 30 in. W x 20 in. D	N/A
150	186	6.0 x 30 in. W x 20 in. D	N/A				
200	248	6.0 x 35 in. W x 20 in. D	N/A				
250	302		N/A				

(1) Adding options can increase the space factor of the unit.

Bulletin 2163U, 2163V PowerFlex 753 and PowerFlex 755 Variable Frequency AC Drive (VFD) with Circuit Breaker Normal Duty

Nominal Hp (kW)	480V			600V			
	Maximum Continuous Output Current (A)	Space Factor ⁽¹⁾		Maximum Continuous Output Current (A)	Space Factor ⁽¹⁾		
		NEMA/UL Type 1 and Type 1 w/Gasket	NEMA/UL Type 12		NEMA/UL Type 1 and Type 1 w/Gasket	NEMA/UL Type 12	
0.5	N/A			0.9	2.5		
0.75	N/A			1.3			
1	2.1	2.0	2.5	1.7			
1.5	3.0			2.4			
2	3.4			2.7			
3	5.0			3.9			
5	8.0			6.1			
7.5	11			9			
10	14	2.5	11	3.0			
15	22	3.0	17				
20	27	2.5	3.5	22	6.0 x 20 in. W x 15 in. D	6.0 x 25 in. W x 15 in. D	
25	34			27			
30	40			32	3.0	6.0 x 25 in. W x 15 in. D	6.0 x 25 in. W x 15 in. D
40	52			41	6.0 x 20 in. W x 15 in. D		
50	65	3.0	4.0	52	6.0 x 25 in. W x 15 in. D	6.0 x 25 in. W x 15 in. D	

Bulletin 2163U, 2163V PowerFlex 753 and PowerFlex 755 Variable Frequency AC Drive (VFD) with Circuit Breaker Normal Duty

Nominal Hp (kW)	480V			600V		
	Maximum Continuous Output Current (A)	Space Factor ⁽¹⁾		Maximum Continuous Output Current (A)	Space Factor ⁽¹⁾	
		NEMA/UL Type 1 and Type 1 w/Gasket	NEMA/UL Type 12		NEMA/UL Type 1 and Type 1 w/Gasket	NEMA/UL Type 12
60	77	6.0 x 20 in. W x 15 in. D	6.0 x 25 W x 15 in. D	63	6.0 x 25 in. W x 20 in. D	6.0 x 25 in. W x 20 in. D
75	96	6.0 x 25 in. W x 15 in. D		77		
100	125	6.0 x 25 in. W x 20 in. D	6.0 x 25 in. W x 20 in. D	99		6.0 x 30 in. W x 20 in. D
125	156		6.0 x 30 in. W x 20 in. D	125		
150	186		6.0 x 35 in. W x 20 in. D	144		
200	248	6.0 x 30 in. W x 20 in. D	N/A			
250	302	6.0 x 35 in. W x 20 in. D	N/A			
300	361					
350	415					

(1) Adding options can increase the space factor of the unit.

Bulletin 2163U, 2163V PowerFlex 753 and PowerFlex 755 Variable Frequency AC Drive (VFD) with Circuit Breaker, Heavy Duty

Nominal Hp (kW)	480V			600V		
	Maximum Continuous Output Current (A)	Space Factor ⁽¹⁾		Maximum Continuous Output Current (A)	Space Factor ⁽¹⁾	
		NEMA/UL Type 1 and Type 1 w/Gasket	NEMA/UL Type 12		NEMA/UL Type 1 and Type 1 w/Gasket	NEMA/UL Type 12
0.5	N/A			0.9	2.5	2.5
0.75	N/A			1.3		
1	2.1	2.0	2.5	1.7		
1.5	3.0			2.4		
2	3.4			2.7		
3	5.0			3.9		
5	8.0			6.1		
7.5	11			9		
10	14			11		
15	22			17		
20	27	2.5	3.5	22	3.0	4.0
25	34	2.5	27			
30	40	3.0	4.0	32	6.0 x 20 in. W x 15 in. D	6.0 x 25 in. W x 15 in. D
40	52			41		
50	65	6.0 x 20 in. W x 15 in. D	6.0 x 25 in. W x 15 in. D	52	6.0 x 25 in. W x 20 in. D	6.0 x 25 in. W x 20 in. D
60	77	6.0 x 25 in. W x 15 in. D	63			
75	96	6.0 x 25 in. W x 20 in. D	6.0 x 25 in. W x 20 in. D	77		6.0 x 30 in. W x 20 in. D
100	125		6.0 x 30 in. W x 20 in. D	99		
125	156		6.0 x 35 in. W x 20 in. D	125		
150	186	6.0 x 30 in. W x 20 in. D	N/A			
200	248	6.0 x 35 in. W x 20 in. D	N/A			
250	302					
250	361					

(1) Adding options can increase the space factor of the unit.

PowerFlex 755TS AC Drive

These combination variable frequency AC motor drive units are specifically designed for use in CENTERLINE motor control centers. Each unit contains a high performance, microprocessor-controlled, variable frequency AC drive and either a fusible disconnect switch or a circuit breaker.

2163VT Combination PowerFlex 755TS Variable Frequency AC Drive (VFD) with Circuit Breaker, Normal Duty

Nominal HP	380...400V		
	Maximum Continuous output Current (A)	Minimum Space Factor	
		NEMA/UL Type 1 and Type 1 w/Gasket	NEMA/UL Type 12
1	2.1	2.5	2.5
2	3.5		
3	5		
5	8.7		
7	11.5		
10	15.5		
15	22	2.0	3.0
20	30	3.0	3.5
25	37		
29	43		
40	60	3.5	6.0 x 20 in. W x 15 in. D
50	72		
60	85		
74	104		
101	140	6.0 x 25 in. W x 20 in. D	6.0 x 30in. W x 20 in. D
121	170		6.0 x 35 in. W x 20 in. D
147	205		
177	260	6.0 x 30 in. W x 20 in. D	N/A

2163VT Combination PowerFlex 755TS Variable Frequency AC Drive (VFD) with Circuit Breaker, Heavy Duty

Nominal HP	380...400V		
	Maximum Continuous output Current (A)	Minimum Space Factor	
		NEMA/UL Type 1 and Type 1 w/Gasket	NEMA/UL Type 12
1	2.1	2.5	2.5
2	3.5		
3	5		
5	8.7		
7	11.5		
10	15.4		
15	22	2.0	3.0
20	30	3.0	3.5
25	37		
29	43		
40	60	3.5	6.0 x 20 in. W x 15 in. D
50	72		
60	85		
74	104		
101	140	6.0 x 25 in. W x 20 in. D	6.0 x 30in. W x 20 in. D
121	170		
147	205		N/A

Bulletin 2162VT PowerFlex 755TS Variable Frequency AC Drive (VFD) with Fusible Disconnect, Normal Duty

Nominal HP	480V		
	Maximum Continuous output Current (A)	Minimum Space Factor	
		NEMA/UL Type 1 and Type 1 w/Gasket	NEMA/UL Type 12
1	2.1	2.0	2.5
1.5	3		
2	3.4		
3	5		
5	8		
7.5	11		
10	14	2.5	3.0
15	22		
20	27		
25	34	3.0	3.5
30	40		
40	52	3.5	4.0
50	65		
60	77	6.0 x 20 in. W x 15 in. D	6.0 x 25 in. W x 15 in. D
75	96	6.0 x 25 in. W x 15 in. D	
100	125	6.0 x 25 in. W x 20 in. D	6.0 x 30 in. W x 20 in. D
125	156		6.0 x 35 in. W x 20 in. D
150	186		6.0 x 35 in. W x 20 in. D
200	248	6.0 x 35 in. W x 20 in. D	N/A
250	302		
300	361		

Bulletin 2162VT PowerFlex 755TS Variable Frequency AC Drive (VFD) with Fusible Disconnect, Heavy Duty

Nominal HP	480V		
	Maximum Continuous output Current (A)	Minimum Space Factor	
		NEMA/UL Type 1 and Type 1 w/Gasket	NEMA/UL Type 12
1	2.1	2.0	2.5
1.5	3		
2	3.4		
3	5		
5	8		
7.5	11		
10	14	2.5	3.0
15	22		
20	27		
25	34	3.0	3.5
30	40		
40	52	3.0	4.0
50	65		
60	77	6.0 x 20 in. W x 15 in. D	6.0 x 25 in. W x 15 in. D
75	96	6.0 x 25 in. W x 15 in. D	
100	125	6.0 x 25 in. W x 20 in. D	6.0 x 25 in. W x 20 in. D
125	156		6.0 x 30 in. W x 20 in. D
			6.0 x 35 in. W x 20 in. D

Bulletin 2162VT PowerFlex 755TS Variable Frequency AC Drive (VFD) with Fusible Disconnect, Heavy Duty (Continued)

Nominal HP	480V		
	Maximum Continuous output Current (A)	Minimum Space Factor	
		NEMA/UL Type 1 and Type 1 w/Gasket	NEMA/UL Type 12
150	186	6.0 x 30 in. W x 20 in. D	...
200	248	6.0 x 35 in. W x 20 in. D	
250	302		

Bulletin 2163VT PowerFlex 755TS Variable Frequency AC Drive (VFD) with Circuit Breaker, Normal Duty

Nominal HP	480V		
	Maximum Continuous output Current (A)	Minimum Space Factor	
		NEMA/UL Type 1 and Type 1 w/Gasket	NEMA/UL Type 12
1	2.1	2.0	2.5
1.5	3		
2	3.4		
3	5		
5	8		
7.5	11		
10	14		
15	22	2.5	3.0
20	27	3.0	3.5
25	34		
30	40		
40	52	3.0	4.0
50	65	3.5	
60	77	6.0 x 25 in. W x 15 in. D	6.0 x 25 in. W x 15 in. D
75	96		
100	125	6.0 x 25 in. W x 20 in. D	6.0 x 25 in. W x 20 in. D
125	156		6.0 x 30 in. W x 20 in. D
150	186		6.0 x 35 in. W x 20 in. D
200	248	6.0 x 30 in. W x 20 in. D	N/A
250	302	6.0 x 35 in. W x 20 in. D	
300	361		
350	415		

Bulletin 2163VT PowerFlex 755TS Variable Frequency AC Drive (VFD) with Circuit Breaker, Heavy Duty

Nominal HP	480V		
	Maximum Continuous output Current (A)	Minimum Space Factor	
		NEMA/UL Type 1 and Type 1 w/Gasket	NEMA/UL Type 12
1	2.1	2.0	2.5
1.5	3		
2	3.4		
3	5		
5	8		
7.5	11		
10	14	2.5	3.0
15	22	3.0	3.5
20	27		
25	34	3.5	4.0
30	40	3.0	
40	52	3.5	
50	65	6.0 x 25 in. W x 15 in. D	6.0 x 25 in. W x 15 in. D
60	77		
75	96	6.0 x 25 in. W x 20 in. D	6.0 x 25 in. W x 20 in. D
100	125		6.0 x 30 in. W x 20 in. D
125	156		6.0 x 35 in. W x 20 in. D
150	186	6.0 x 30 in. W x 20 in. D	N/A
200	248	6.0 x 35 in. W x 20 in. D	
250	302		
300	361		

PowerFlex 525 AC Drive

These combination variable frequency AC motor drive units are specifically designed for use in CENTERLINE motor control centers. Each unit contains a high performance, microprocessor-controlled, variable frequency AC drive and either a fusible disconnect switch or a circuit breaker.

2162W Combination PowerFlex 525 Variable Frequency AC Drive (VFD) Units with Fusible Disconnect, 480V AC, Normal Duty

Maximum Continuous Output Current (A)	Nominal Hp	NEMA/UL Type 1 and Type 1 w/ gasket	NEMA/UL 12
	480V	Space Factor	Space Factor
1.4	0.5	1.0	1.5
1.7	0.75	1.0	1.5
2.3	1.0	1.0	1.5
3.0	1.5	1.0	2.0
4.0	2.0	1.0	2.0
6.0	3.0	1.0	2.0
10.5	5.0	1.0	2.0
13	7.5	2.0	2.5
17	10	2.0	2.5
24	15	2.0	3.0
30	20	2.5	3.5

2162W Combination PowerFlex 525 Variable Frequency AC Drive (VFD) Units with Fusible Disconnect, 600V AC, Normal Duty

Maximum Continuous Output Current (A)	Nominal Hp	NEMA/UL Type 1 and Type 1 w/ gasket	NEMA/UL 12
	600V	Space Factor	Space Factor(3)
0.9	0.5	1.0	1.5
1.3	0.75	1.0	1.5
1.7	1.0	1.0	1.5
2.2	1.5	1.0	2.0
3.0	2.0	1.0	2.0
4.2	3.0	1.0	2.0
6.6	5.0	1.0	2.0
9.9	7.5	2.0	2.5
12	10	2.0	2.5
19	15	2.0	3.0
22	20	2.5	3.5

2163W Combination PowerFlex 525 Variable Frequency AC Drive (VFD) Units with Circuit Breaker, 480V AC, Normal Duty

Maximum Continuous Output Current (A)	Nominal Hp	NEMA/UL Type 1 and Type 1 w/ gasket	NEMA/UL 12
	480V	Space Factor	Space Factor
1.4	0.5	1.0	1.5
1.7	0.75	1.0	1.5
2.3	1.0	1.0	1.5
3.0	1.5	1.0	2.0
4.0	2.0	1.0	2.0
6.0	3.0	1.0	2.0
10.5	5.0	1.0	2.0
13	7.5	2.0	2.5
17	10	2.0	2.5
24	15	2.0	3.0
30	20	2.5	3.5

2163W Combination PowerFlex 525 Variable Frequency AC Drive (VFD) Units with Circuit Breaker, 600V AC, Normal Duty

Maximum Continuous Output Current (A)	Nominal Hp	NEMA/UL Type 1 and Type 1 w/ gasket	NEMA/UL 12
	600V	Space Factor	Space Factor
0.9	0.5	1.0	1.5
1.3	0.75	1.0	1.5
1.7	1.0	1.0	1.5
2.2	1.5	1.0	2.0
3.0	2.0	1.0	2.0
4.2	3.0	1.0	2.0
6.6	5.0	1.0	2.0
9.9	7.5	2.0	2.5
12	10	2.0	2.5
19	15	2.0	3.0
22	20	2.5	3.5

PowerFlex 523 AC Drive

These combination variable frequency AC motor drive units are specifically designed for use in CENTERLINE motor control centers. Each unit contains a high performance, microprocessor-controlled, variable frequency AC drive and either a fusible disconnect switch or a circuit breaker.

2162X Combination PowerFlex 523 Variable Frequency AC Drive (VFD) Units with Fusible Disconnect, 480V AC, Normal Duty

Maximum Continuous Output Current (A)	Nominal Hp	NEMA/UL Type 1 and Type 1 w/ gasket	NEMA/UL 12
	480V	Space Factor	Space Factor
1.4	0.5	1.0	1.5
1.7	0.75	1.0	1.5
2.3	1.0	1.0	1.5
3.0	1.5	1.0	2.0
4.0	2.0	1.0	2.0
6.0	3.0	1.0	2.0
10.5	5.0	1.0	2.0
13	7.5	2.0	2.5
17	10	2.0	2.5
24	15	2.0	3.0

2162X Combination PowerFlex 523 Variable Frequency AC Drive (VFD) Units with Fusible Disconnect, 600V AC, Normal Duty

Maximum Continuous Output Current (A)	Nominal Hp	NEMA/UL Type 1 and Type 1 w/ gasket	NEMA/UL 12
	600V	Space Factor	Space Factor
0.9	0.5	1.0	1.5
1.3	0.75	1.0	1.5
1.7	1.0	1.0	1.5
2.2	1.5	1.0	2.0
3.0	2.0	1.0	2.0
4.2	3.0	1.0	2.0
6.6	5.0	1.0	2.0
9.9	7.5	2.0	2.5
12	10	2.0	2.5
19	15	2.0	3.0

2163X Combination PowerFlex 523 Variable Frequency AC Drive (VFD) Units with Circuit Breaker, 480V AC, Normal Duty

Maximum Continuous Output Current (A)	Nominal Hp	NEMA/UL Type 1 and Type 1 w/ gasket	NEMA/UL 12
	480V	Space Factor	Space Factor
1.4	0.5	1.0	1.5
1.7	0.75	1.0	1.5
2.3	1.0	1.0	1.5
3.0	1.5	1.0	2.0
4.0	2.0	1.0	2.0
6.0	3.0	1.0	2.0
10.5	5.0	1.0	2.0
13	7.5	2.0	2.5
17	10	2.0	2.5
24	15	2.0	3.0

2163X Combination PowerFlex 523 Variable Frequency AC Drive (VFD) Units with Circuit Breaker, 600V AC, Normal Duty

Maximum Continuous Output Current (A)	Nominal Hp	NEMA/UL Type 1 and Type 1 w/ gasket	NEMA/UL 12
	600V	Space Factor	Space Factor
0.9	0.5	1.0	1.5
1.3	0.75	1.0	1.5
1.7	1.0	1.0	1.5
2.2	1.5	1.0	2.0
3.0	2.0	1.0	2.0
4.2	3.0	1.0	2.0
6.6	5.0	1.0	2.0
9.9	7.5	2.0	2.5
12	10	2.0	2.5
19	15	2.0	3.0

Programmable Automation Controller Units

The Bulletin 2180L, 2182L and 2183L units include a choice of one 4-slot or one 7-slot Bulletin 1756 ControlLogix™ chassis.

Unit features:

Without disconnecting means or plug-in stabs:

- 4-slot chassis, 1.0 space factor.
- 7-slot chassis, 2.0 space factor (frame mounted unit, section does not have vertical wireway next to this unit). Bottom mounted only.

With disconnecting means:

- Fusible disconnect (30 A switch), plug-in stabs, control circuit transformer, 4-slot chassis, 1.5 space factor.
- Fusible disconnect (30 A switch) without plug-in stabs, control circuit transformer, 7-slot chassis, 2.0 space factor (frame mounted unit, section does not have vertical wireway next to this unit). Bottom mounted only.
- Circuit breaker (15 A trip), plug-in stabs, control circuit transformer, 4-slot chassis, 1.5 space factor.
- Circuit breaker (15 A trip) without plug-in stabs, control circuit transformer, 7-slot chassis, 2.0 space factor (frame mounted unit, section does not have vertical wireway next to this unit). Bottom mounted only.

Unit options include:

- Processor cards (all memory upgrade options).
- Communication cards (Ethernet, ControlNet, DeviceNet, RI/O, DH+).
- Power supply (10.0 A)

Bulletin 2180L, 2182L, 2183L ControlLogix Programmable Controller (PLC)

Bulletin	I/O Chassis		Space Factor ⁽¹⁾
	Chassis Quantity	Chassis Size	
2180L Basic I/O chassis without disconnecting means or plug-in stabs. Includes viewing window.	1	4 slot	1.0
	1	7 slot	2.0
2182L Basic I/O chassis with disconnect and transformer. Includes viewing window.	1	4 slot	1.5
	1	7 slot	2.0
2183L Basic I/O chassis with circuit breaker and transformer. Includes viewing window.	1	4 slot	1.5
	1	7 slot	2.0

(1) Adding options can increase the space factor of the unit.

Hardware Kits for Field Installation

CENTERLINE 2100 MCC offer section and unit hardware kits such as Bus Splice or Isolation hardware, ground splice kits; see CENTERLINE 2100 Motor Control Centers publication [2100-CA004](#) for more information.

Notes:

Additional Resources

For assembled motor control centers, the customer is supplied with a copy of the motor control center layout and specification and the CENTERLINE 2100 Motor Control Centers Installation Instructions, publication [2100-IN012](#). The Receiving, Handling and Storing Motor Control Centers Instructions, publication [2100-IN040](#), is attached to the outside packaging of each shipping block.

Up to three electronic documentation CDs can be also be provided at no additional cost for each MCC. The CD contains the following:

- Equipment list (elevation, layout specification) drawings
- One-line diagrams (if requested)
- Unit wiring diagrams
- Spare parts list
- User and installation manuals for Rockwell Automation products, supplied in the specific motor control center
- Test reporting

These documents contain additional information concerning related products from Rockwell Automation. You can view or download publications at rok.auto/literature.

Resource	Description
CENTERLINE Motor Control Centers Power Fuses Product Data, publication 2100-TD003	Provides information and specifications for fuse use in motor control centers.
CENTERLINE Motor Control Centers Mains and Incoming Lines Dimensions Reference, publication 2100-TD018	Provides dimensions drawings for lug compartments, main fusible disconnects, main circuit breakers, and conduit entry.
DeviceNet Motor Control Centers (MCC) Technical Data, publication 2100-TD019	Provides information for motor control centers using a DeviceNet network.
CENTERLINE Motor Control Centers with EtherNet/IP, publication 2100-TD031	Provides information for motor control centers using an EtherNet/IP network.
CENTERLINE 2100 Motor Circuit Protection Technical Data, publication 2100-TD032	Provides information for motor circuit protection in units with catalog suffix code 'T' or with Bulletin 140G and 140MG circuit breakers.
CENTERLINE 2100 Low Voltage Motor Control Centers 65 kA Arc Resistant Device Limited and Time Duration Testing Technical Data, publication 2100-TD033	Provides information on certification for arc resistant testing.
CENTERLINE 2100 MCC Specification Checklist, publication 2100-SR003	Provides a checklist for selecting your motor control center.
CENTERLINE 2100 MCC Specification Guide, CSI Format, publication 2100-SR007	Provides procurement specifications for selecting your motor control center.
DeviceNet CENTERLINE Motor Control Centers Specification Guide 2100-SR008	Provides specifications for selecting your DeviceNet motor control center.
CENTERLINE 2100 Motor Control Centers, publication 2100-IN012	Provides information for the installation and use of your motor control center.
Power System Configuration Considerations for Selection of CENTERLINE 2100 MCCs, publication 2100-AT003	Provides considerations for selecting the power system configuration for your motor control center.
IntelliCENTER Software User Manual, publication MCC-UM002	Provides information for using IntelliCENTER software.
IntelliCENTER EtherNet/IP Motor Control Centers Reference Manual, publication MCC-RM001	Provides information regarding the EtherNet/IP network in your motor control center.
E300/E200 Electronic Overload Relay Technical Data, publication 193-TD006	Provides technical specifications for the Allen-Bradley® E300 and E200 overload relays for motor control applications, and for the three modules of each relay.
E100 Electronic Overload Relay Specifications Technical Data, publication 193-TD013	Provides technical specifications for the Allen-Bradley E100 electronic overload relays for motor control applications.
PowerFlex 750-series AC Drives Technical Data, publication 750-TD001	Provides technical specifications for the 750-series AC drives in various frame sizes, and in wall mount, floor mount, and roll out models.
PowerFlex 750-Series Products with TotalFORCE Control, publication 750-TD100	Provides technical specifications for the 750-series AC drives with TotalFORCE Control in various frame sizes, and in wall mount, floor mount, and roll out models.
ControlLogix System Selection Guide, publication 1756-SG001	Provides an overview of the various 1756 Series ControlLogix systems, which provide discrete, drives, motion, process, and safety control.
UL Standards Listing for Industrial Control Products, publication CMPNTS-SR002	Assists original equipment manufacturers (OEMs) with construction of panels, to help ensure that they conform to the requirements of Underwriters Laboratories.
American Standards, Configurations, and Ratings: Introduction to IC-AT001 Motor Circuit Design, publication	Provides an overview of American motor circuit design based on methods that are outlined in the NEC.
Industrial Components Preventive Maintenance, Enclosures, and Contact Ratings Specifications, publication IC-TD002	Provides a quick reference tool for Allen-Bradley industrial automation controls and assemblies.
Safety Guidelines for the Application, Installation, and Maintenance of Solid-state Control, publication SBI-1.1	Designed to harmonize with NEMA Standards Publication No. ICS 1.1-1987 and provides general guidelines for the application, installation, and maintenance of solid-state control in the form of individual devices or packaged assemblies incorporating solid-state components.
Industrial Automation Wiring and Grounding Guidelines, publication 1770-4.1	Provides general guidelines for installing a Rockwell Automation industrial system.
Product Certifications website, rok.auto/certifications .	Provides declarations of conformity, certificates, and other certification details.

Rockwell Automation Support

Use these resources to access support information.

Technical Support Center	Find help with how-to videos, FAQs, chat, user forums, Knowledgebase, and product notification updates.	rok.auto/support
Local Technical Support Phone Numbers	Locate the telephone number for your country.	rok.auto/phonesupport
Technical Documentation Center	Quickly access and download technical specifications, installation instructions, and user manuals.	rok.auto/techdocs
Literature Library	Find installation instructions, manuals, brochures, and technical data publications.	rok.auto/literature
Product Compatibility and Download Center (PCDC)	Download firmware, associated files (such as AOP, EDS, and DTM), and access product release notes.	rok.auto/pcdc

Documentation Feedback

Your comments help us serve your documentation needs better. If you have any suggestions on how to improve our content, complete the form at rok.auto/docfeedback.

Allen-Bradley, Accu-Stop, ArcShield, CENTERLINE, ControlLogix, E300, EnergyMetrix, expanding human possibility, FactoryTalk, GuardLogix, IntelliCENTER, PowerFlex, PowerMonitor, Rockwell Automation, SecureConnect, SMC, SMC-3, SMC Flex, Stratix, and Studio 5000 are trademarks of Rockwell Automation, Inc.

DeviceNet and EtherNet/IP are trademarks of ODVA, Inc.

Trademarks not belonging to Rockwell Automation are property of their respective companies.

Rockwell Automation maintains current product environmental compliance information on its website at rok.auto/pec.

Rockwell Otomasyon Ticaret A.Ş. Kar Plaza İş Merkezi E Blok Kat:6 34752, İçerenköy, İstanbul, Tel: +90 (216) 5698400 EEE Yönetmeliğine Uygundur

Connect with us.    

rockwellautomation.com ————— expanding **human possibility**[®]

AMERICAS: Rockwell Automation, 1201 South Second Street, Milwaukee, WI 53204-2496 USA, Tel: (1) 414.382.2000, Fax: (1) 414.382.4444

EUROPE/MIDDLE EAST/AFRICA: Rockwell Automation NV, Pegasus Park, De Kleetlaan 12a, 1831 Diegem, Belgium, Tel: (32) 2663 0600, Fax: (32) 2 663 0640

ASIA PACIFIC: Rockwell Automation SEA Pte Ltd, 2 Corporation Road, #04-05, Main Lobby, Corporation Place, Singapore 618494, Tel: (65) 6510 6608, FAX: (65) 6510 6699

UNITED KINGDOM: Rockwell Automation Ltd., Pitfield, Kiln Farm, Milton Keynes, MK11 3DR, United Kingdom, Tel: (44)(1908) 838-800, Fax: (44)(1908) 261-917

Publication 2100-SG003G-EN-P - July 2025

Supersedes Publication 2100-SG003F-EN-P - October 2023

Copyright © 2025 Rockwell Automation, Inc. All rights reserved. Printed in the U.S.A.