

THIS COPY IS PROVIDED ON A RESTRICTED BASIS AND IS NOT TO BE USED IN ANY WAY DETRIMENTAL TO THE INTERESTS OF PANDUIT CORP.

Material	High Conductivity Seamless Copper Tube
Plating	Electro-Tin
Wire Size	750 STR/FLEX
Wire Type	Stranded Copper: Locomotive
Wire Strip Length	1-3/4 in.
Stud Size	5/8 in.
UL Listed Wire Connector	Yes, for applications up to 35kv. Consult cable manufacturer for voltage stress relief instructions with applications greater than 2000 volts.
UL Temperature Rating	90° C
C.S.A Certified Wire Connector	Yes
Panduit Color Code on Barrel	YELLOW
Panduit Die Index No. on Barrel	P115
Alternate Industry Die Index No. ( ) on Barrel	(L115)



CERTIFIED

LISTED Wire Connector

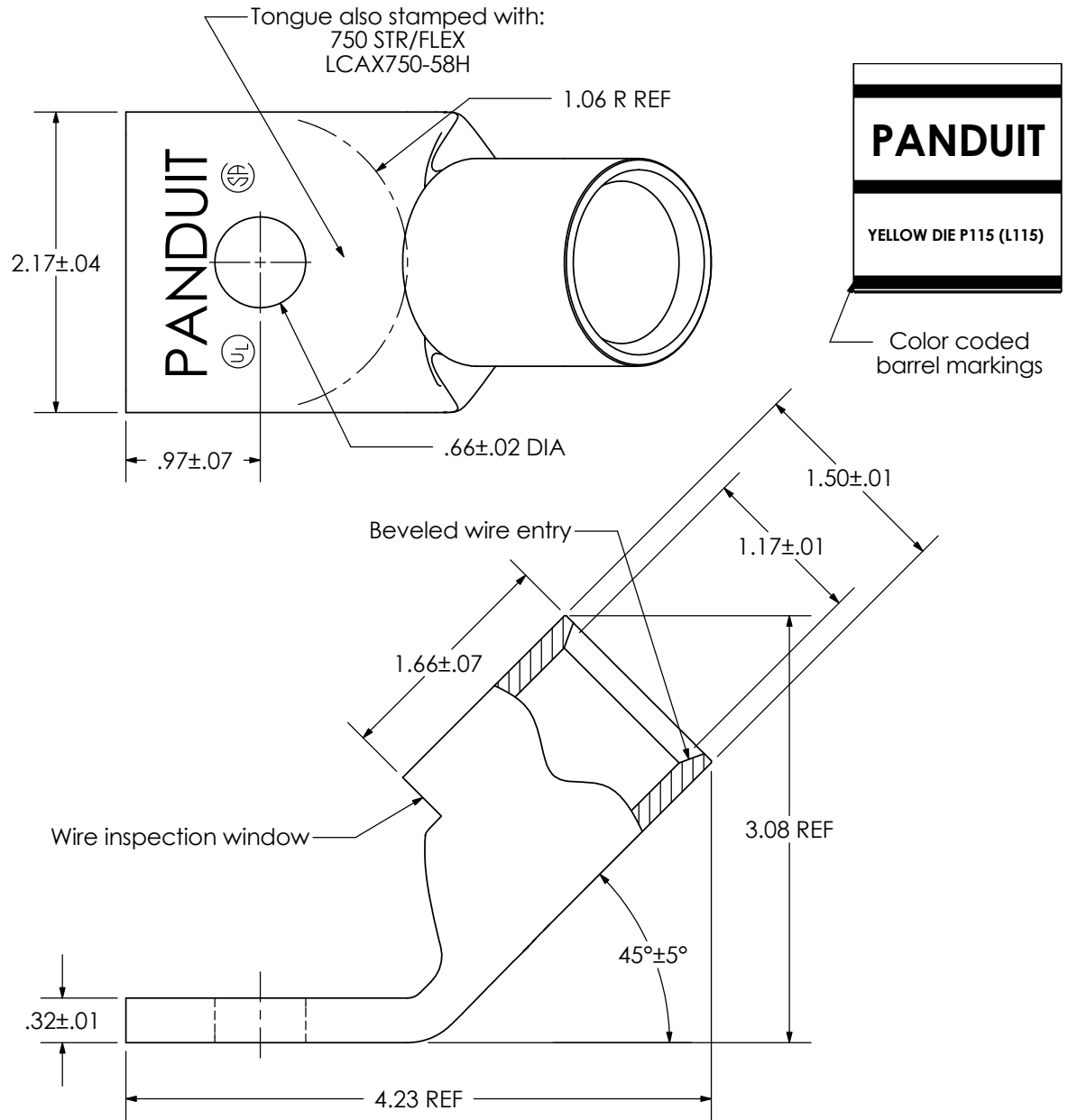

REV	DATE	BY	CHK	DESCRIPTION	ECN	SCALE	DRAWING NO / CAD FILE
01	4/09	JHNU	JHNU	REVISED TOLERANCES: HOLE OFFSET WAS .04, BARREL LENGTH WAS .04		N/A	LCAX750-58H-CUST

**PANDUIT CORP. TINLEY PARK, ILLINOIS**

LCAX750-58H-3  
Copper Lug - One-Hole, Standard Flex Barrel, 45° Angle Tongue

SCALE N/A DRAWING NO / CAD FILE LCAX750-58H-CUST