

Kinetix Linear Motion Specifications

Kinetix MPAS, MPMA, VPAR, MPAR, MPAI, LDAT, LDC, LDL

Topic	Page
Summary of Changes	2
Servo Drive Compatibility	2
Kinetix LDAT Integrated Linear Thrusters	3
Kinetix MPAS Integrated Linear Stages	36
Kinetix MPMA Integrated Multi-axis Linear Stages	55
Kinetix VPAR and Kinetix MPAR Electric Cylinders	78
Kinetix MPAI Heavy-duty Electric Cylinders	114
Kinetix LDC Iron Core Linear Servo Motors	140
Kinetix LDL Ironless Linear Servo Motors	158
Common Linear Motion Specifications	170
Motor Brake Application Guidelines	171
Additional Resources	173

This publication provides catalog numbers and product specifications, including performance, environmental, certifications, and dimension drawings for Allen-Bradley® linear motors and actuators.

Use this publication in conjunction with the Kinetix® Motion Control Selection Guide, publication [KNX-SG001](#), to help make decisions on the motion control product families best suited for your system requirements.

Summary of Changes

This publication contains the following new or updated information. This list includes substantive updates only and is not intended to reflect all changes.

Topic	Page
Added ArmorKinetix® Distributed Servo Drive (DSD) module compatibility with the appropriate Kinetix linear motor and actuator families.	2
Added ArmorKinetix cable information for Kinetix LDAT linear thrusters.	3
Added ArmorKinetix cable information for Kinetix VPAR and Kinetix MPAR electric cylinders.	80
Added ArmorKinetix cable information for Kinetix LDC linear motors.	140

Servo Drive Compatibility

Servo Drive Family	Integrated Linear Thrusters	Integrated Linear Stages		Electric Cylinders			Linear Motors	
	Kinetix LDAT	Kinetix MPAS	Kinetix MPMA	Kinetix VPAR	Kinetix MPAR	Kinetix MPAI	Kinetix LDC	Kinetix LDL
ArmorKinetix DSD	X	—	—	X	X	—	X	—
Kinetix 5700	X	X	X	X	X	X	X	X
Kinetix 5500	X (absolute encoder)	X (ballscrew)	X (ballscrew)	X	X	X	—	—
Kinetix 5300	X	X	X	—	X	X	X	X
Kinetix 5100	X (incremental)	X	X	—	X	X	X	X
Kinetix 6500	X (incremental)	X	X	—	X	X	X	—
Kinetix 6200								
Kinetix 6000	X (incremental)	X	X	—	X	X	X	X
Kinetix 300	X	X	X	—	X	X	X	X
Kinetix 350	—	X (ballscrew)	X (ballscrew)				—	—
Kinetix 3	X (incremental)	X (direct drive)	—	—	—	—	X	X
Kinetix 2000	X	X	X	—	X	X	X	X
Ultra™3000	X	X	X	—	X	X	X	X

Kinetix LDAT Integrated Linear Thrusters



Kinetix LDAT integrated linear thrusters provide machine builders with high-speed, load-bearing linear motion out-of-the-box. The Kinetix LDAT linear thruster is a reliable, high-speed linear actuator with an integrated linear guide that is capable of pushing, pulling, or carrying a load. The linear thruster combines high velocity, high levels of acceleration, and peak thrust forces up to 5469 N (1229 lb) to help maximize performance. Ideal applications are those that currently use a custom-designed belt actuator or linkage device that converts rotary motion into linear, including cartoners, stackers, case packers, case and tray formers, in-out feeds, diverters, ejectors, drop gates, and horizontal conveyors.

Kinetix LDAT Linear Thruster Features

- Increased reliability due to direct-drive technology with single linear guide, single wear item, caged-ball linear bearings, and elimination of wear items associated with rotary to linear motion conversion
- Integrated linear bearing provides the ability to carry a load without having to mount and align external bearings
- Multiple mounting surfaces and methods for ease of mounting into your machine
- Couples directly to the item that needs to be moved
- Available with strip cover option for added bearing protection in harsh environments
- High velocities, up to 5 m/s (16 ft/s), and acceleration, 49 m/s² (160 ft/s²) standard
- Peak forces ranging from 168...5469 N (38...1229 lb)
- Stroke lengths from 100...900 mm (3.9...35.4 in.)
- Motion Analyzer software, version 6.00 or later, for quick and easy sizing

Motor Connector/Cable Compatibility

Kinetix LDAT linear thrusters are equipped with SpeedTec DIN connectors. However, the incremental encoder option (-xBx) requires threaded DIN (M4) feedback cables in non-flex applications. This is due to the number of conductors required for incremental encoder connections.

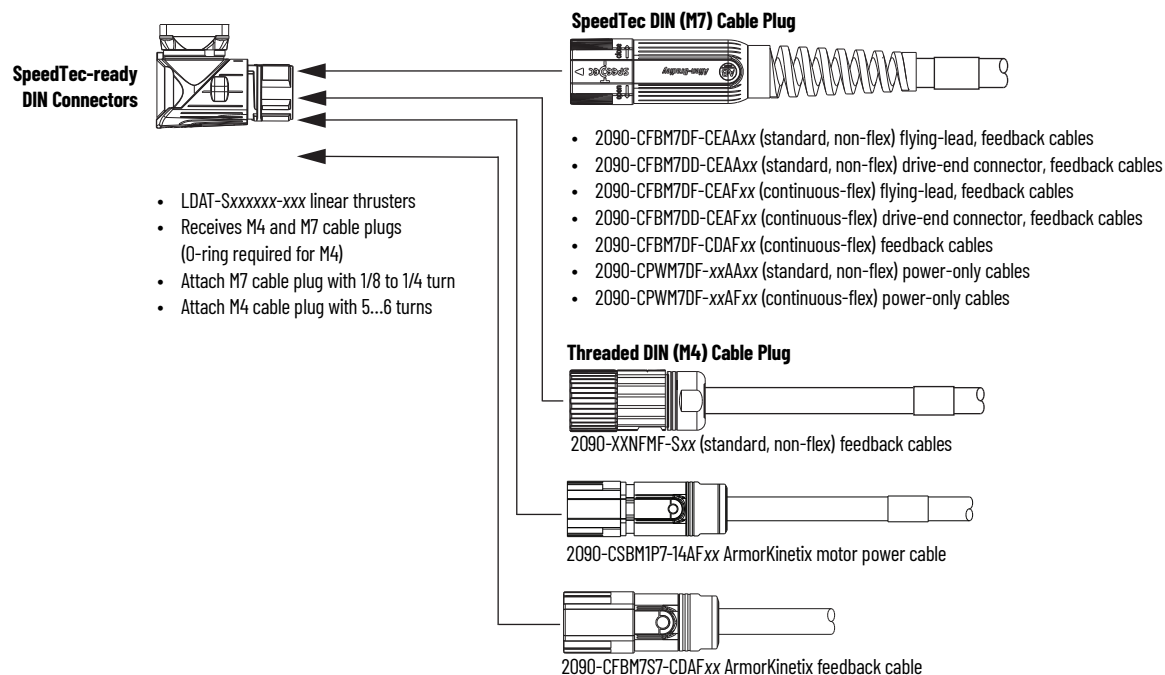

Catalog Numbers - Kinetix LDAT Integrated Linear Thrusters

Catalog numbers consist of various characters, each of which identifies a specific option for that component. Use the catalog numbering table chart below to understand the configuration of your actuator. For questions regarding product availability, contact your Allen-Bradley distributor.

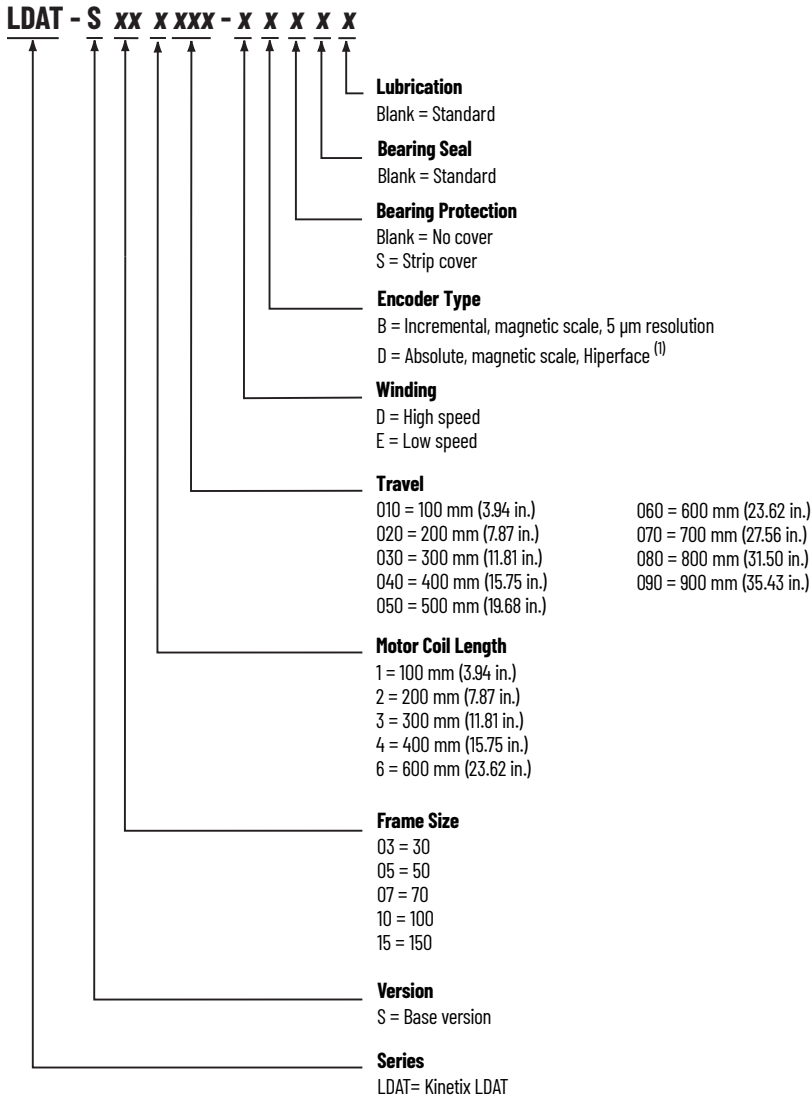

(1) Magnetic strip has 1.0 mm (0.039 in.) pole pitch. Final resolution when used with a Kinetix 300 drive is 0.488 µm (0.000019 in.).

Kinetix LDAT Integrated Linear Thrusters Accessories

These accessory items apply to the Kinetix LDAT linear thrusters.

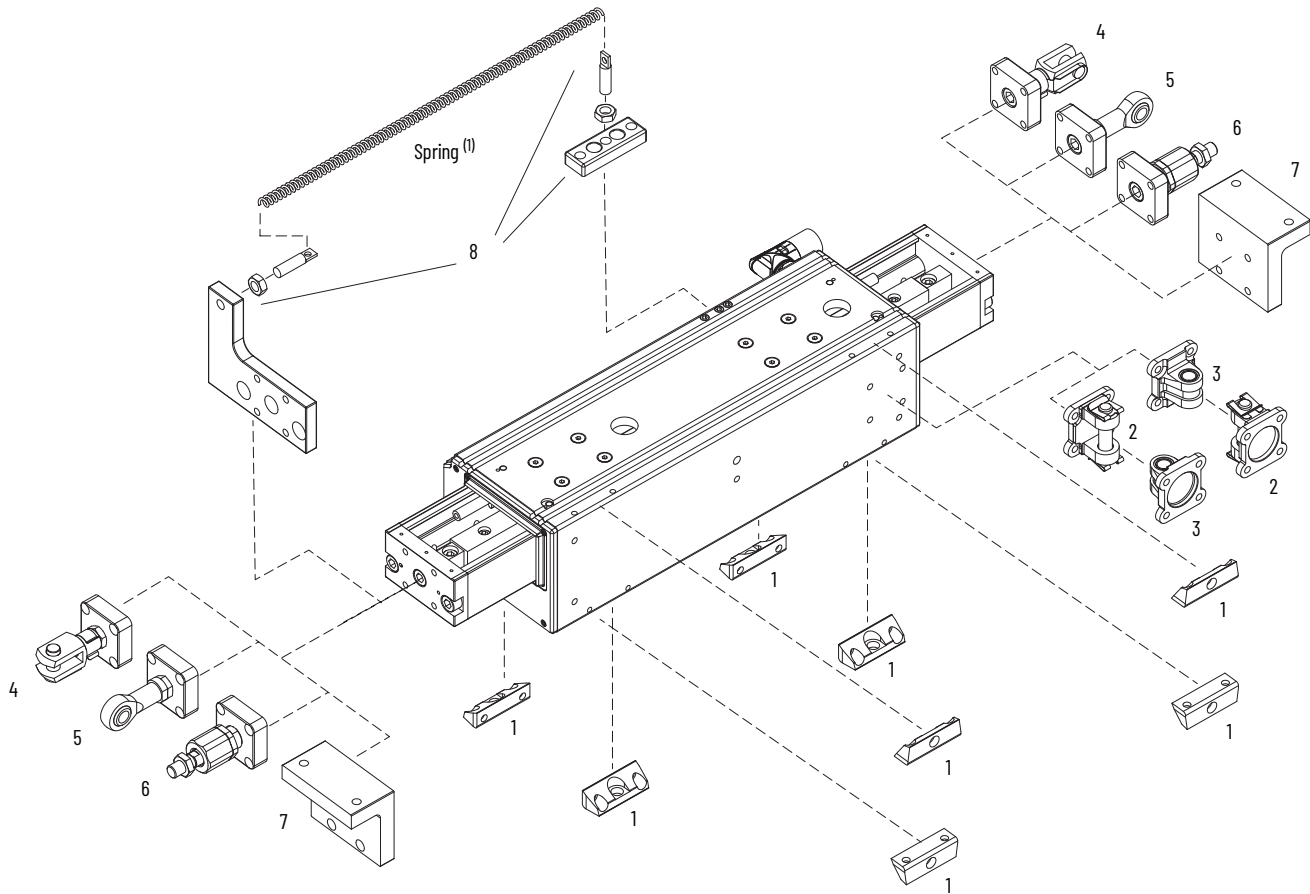

(1) Size and purchase spring according to your application needs. Contact your Rockwell Automation sales representative for assistance.

Mounting Attachments

Accessory Item	Frame	Accessory Cat. No.	Description	Dimensions
1 Foot mount bracket kit	30	LDAT-SMID-FTMOUNT	Use to attach thruster unit to machine with side or bottom mount. Kit includes foot mounts and mounting screws.	page 29
	50			
	70			
	100			
2 Clevis (male) attachment	150	LDAT-SLARGE-FTMOUNT	Use to attach thruster unit to machine with side or bottom mount. Kit includes foot mounts and mounting screws. This kit also includes M6x1.0x25 mounting screws required for center feet on only LDAT-S1x4xxx and LDAT-S1x6xxx thruster units.	
	30	LDAT-S03-CLVSM	Attachment includes flange, pivot pin, retaining clips, and mounting screws.	page 30
	50	LDAT-S0507-CLVSM		
	70			
100	LDAT-S1015-CLVSM			
3 Clevis (female) attachment	150	LDAT-S1015-CLVSF	Attachment includes swivel flange and mounting screws.	page 30
	30	LDAT-S03-CLVSF		
	50	LDAT-S0507-CLVSF		
	70			

Slider-end Attachments

Accessory Item	Frame	Accessory Cat. No.	Description	Dimensions
4 Rod eye kit	30	LDAT-S03-RODEYE	Attachment includes rod-eye, adapter, and mounting bolts.	page 31
	50	LDAT-S0507-RODEYE		
	70			
	100	LDAT-S1015-RODEYE		
	150			
5 Rod clevis kit	30	LDAT-S03-RODCLVS	Attachment includes rod clevis, adapter, hinged spring pin, hex nut, and mounting bolts.	page 32
	50	LDAT-S0507-RODCLVS		
	70			
	100	LDAT-S015-RODCLVS		
	150			
6 Rod coupler kit	30	LDAT-S03-RODCPLR	Attachment includes self-aligning rod coupler, adapter, hex nut, and mounting bolts.	page 33
	50	LDAT-S0507-RODCPLR		
	70			
	100	LDAT-S1015-RODCPLR		
	150			
7 Horizontal payload mounting bracket	30	LDAT-S03-HPBRKT	Attachment includes payload bracket and mounting screws.	page 34
	50	LDAT-S0507-HPBRKT		
	70			
	100	LDAT-S10-HPBRKT		
	150	LDAT-S15-HPBRKT		
8 Counterbalance kit	30	LDAT-S03-CBRKT	Kit includes slide-end bracket, stator bracket, spring anchors with hex nuts, and socket head cap screws. Extension springs are customer-supplied and specific to each application.	page 35
	50	LDAT-S0507-CBRKT		
	70			
	100	LDAT-S10-CBRKT		
	150	LDAT-S15-CBRKT		

Technical Specifications - Kinetix LDAT Integrated Linear Thrusters

Product specifications include information on mounting options, payload and deflection, performance, and weights.

Mounting Options

The Kinetix LDAT linear thrusters can be mounted by using the foot mount brackets relative to the coil side or cable connector side of the unit.

Coil Side Mounting

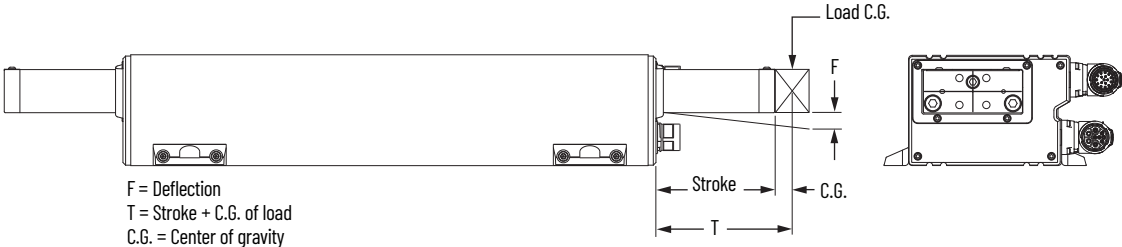

Side Opposite Connectors Mounting

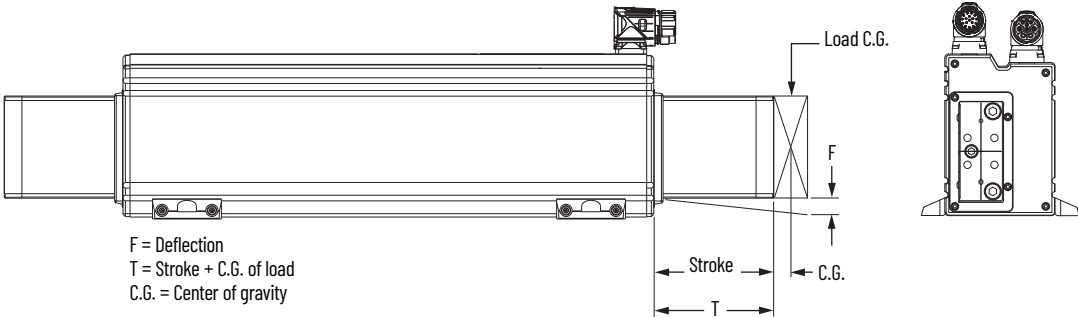

Payload Limitation and Deflection Specifications

Maximum Load at T (Frame 30)

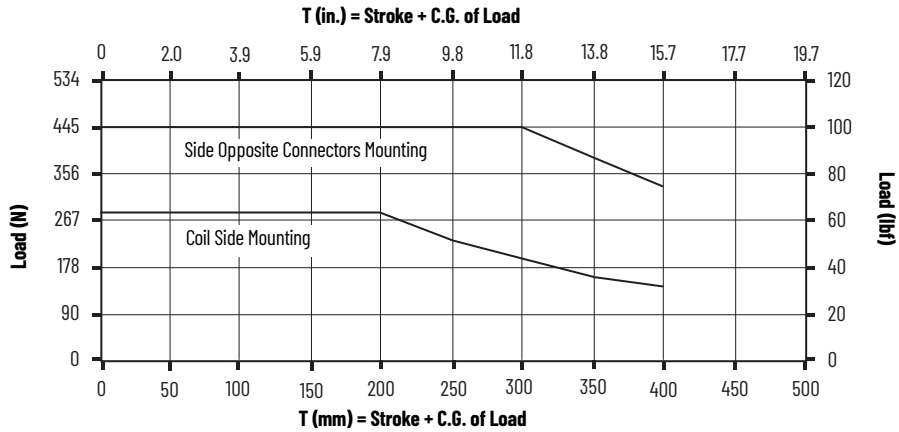

Cantilever Beam Deflection (Frame 30) When Mounted on the Coil Side

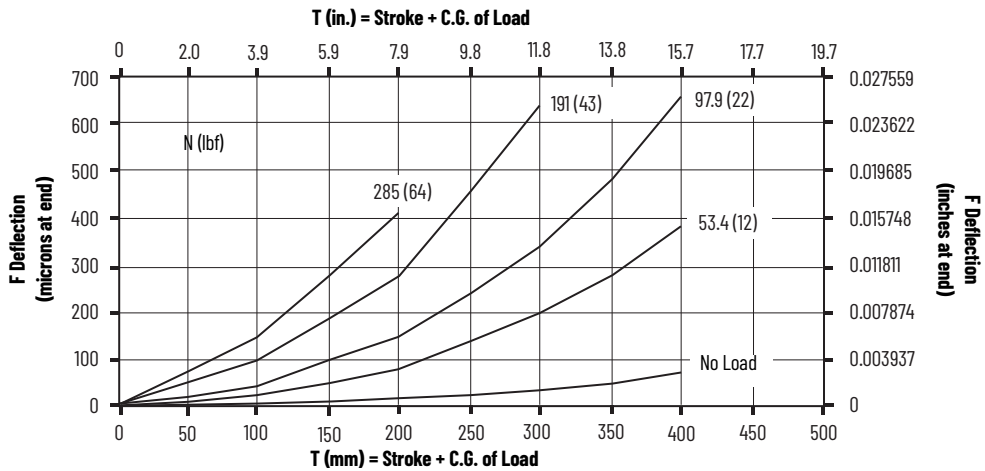

Cantilever Beam Deflection (Frame 30) When Mounted on the Side Opposite Connectors

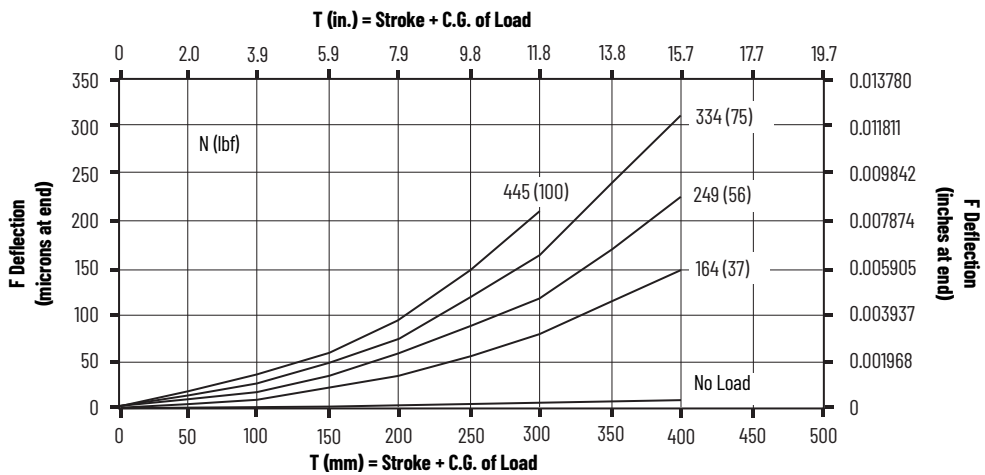

Maximum Load at T (Frame 50 and 70)

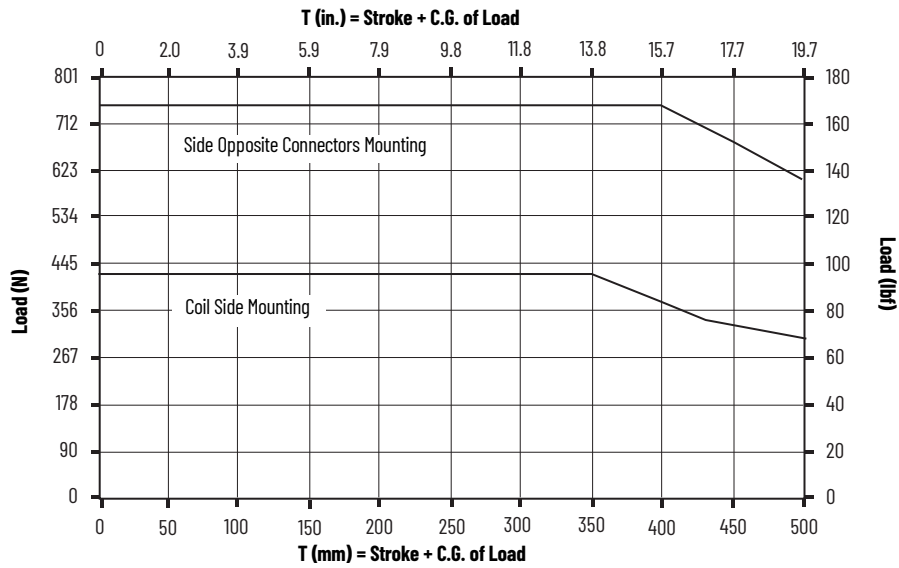

Cantilever Beam Deflection (Frame 50 and 70) When Mounted on the Coil Side

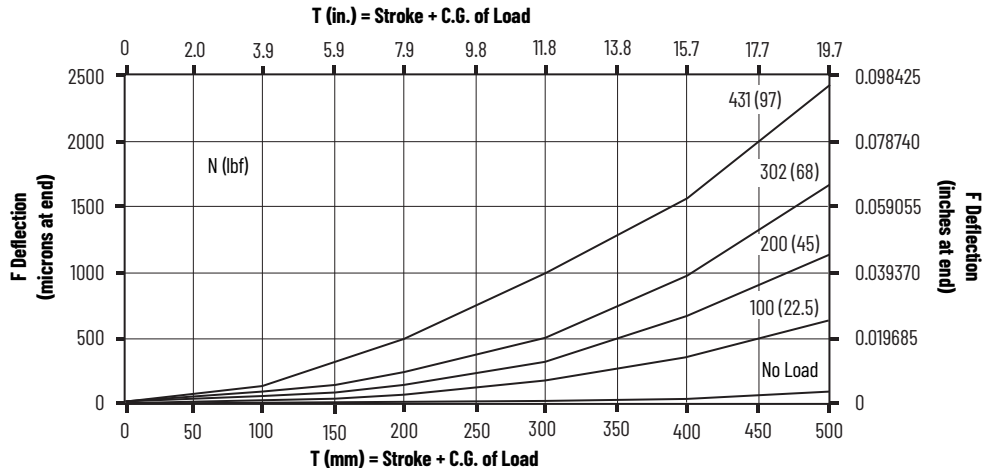

Cantilever Beam Deflection (Frame 50 and 70) When Mounted on the Side Opposite Connectors

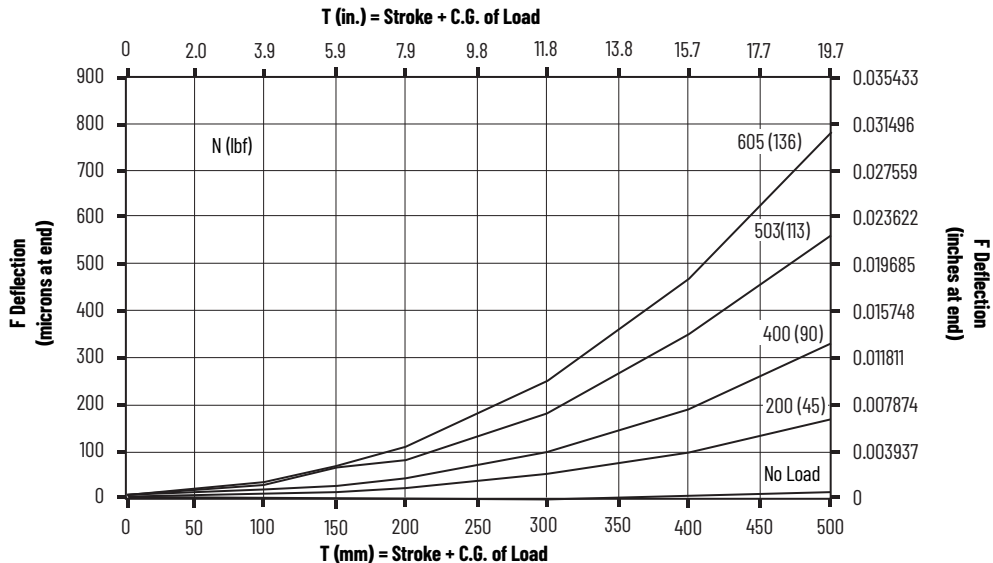

Maximum Load at T (Frame 100)

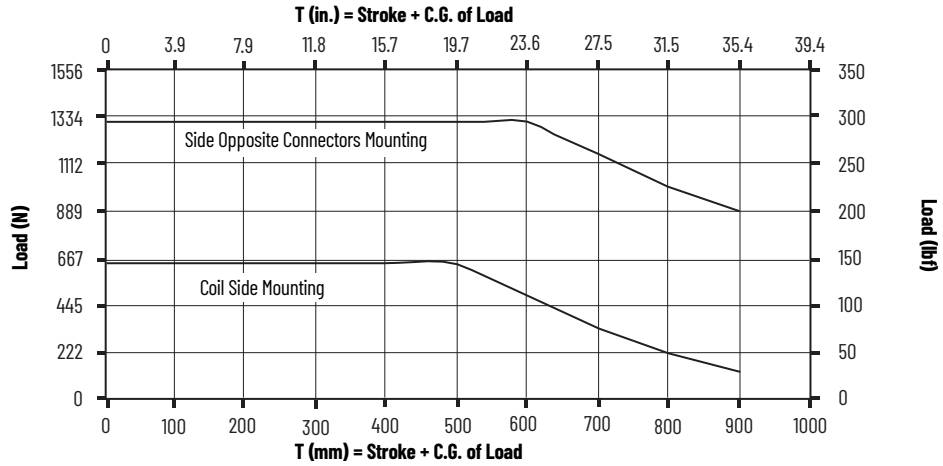

Cantilever Beam Deflection (Frame 100) When Mounted on the Coil Side

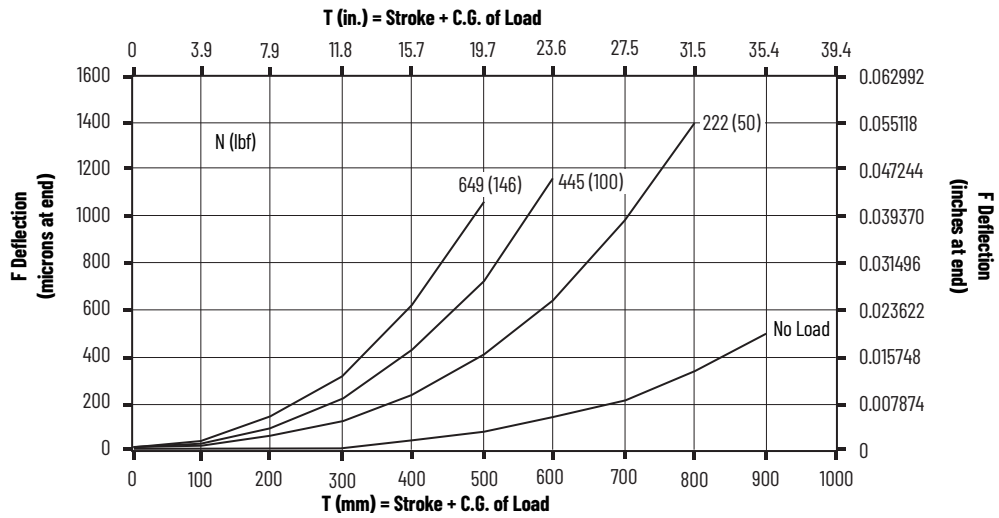

Cantilever Beam Deflection (Frame 100) When Mounted on the Side Opposite Connectors

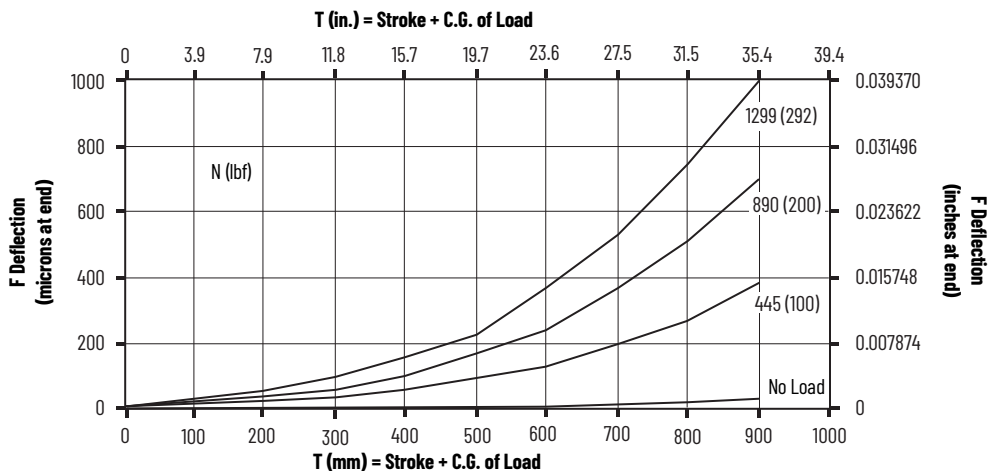

Maximum Load at T (Frame 150)

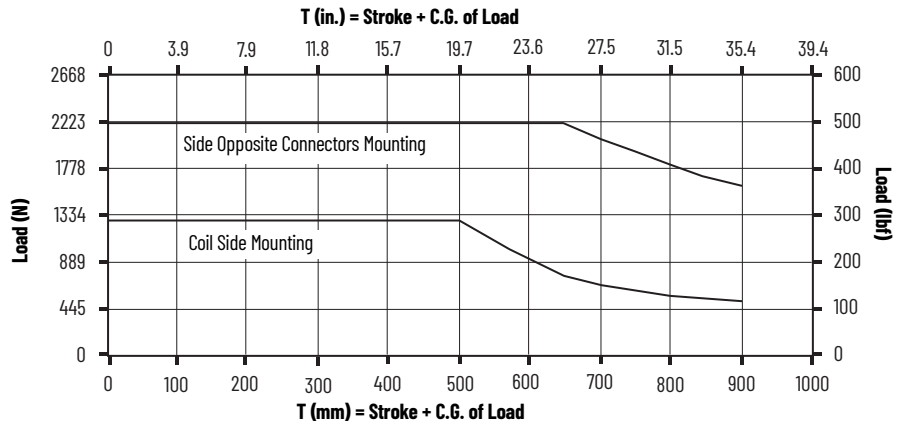

Cantilever Beam Deflection (Frame 150) When Mounted on the Coil Side

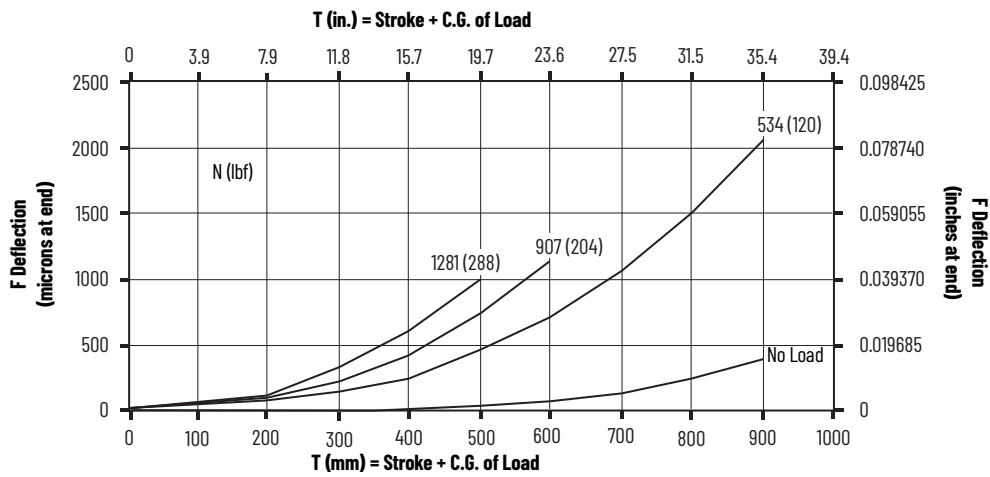

Cantilever Beam Deflection (Frame 150) When Mounted on the Side Opposite Connectors

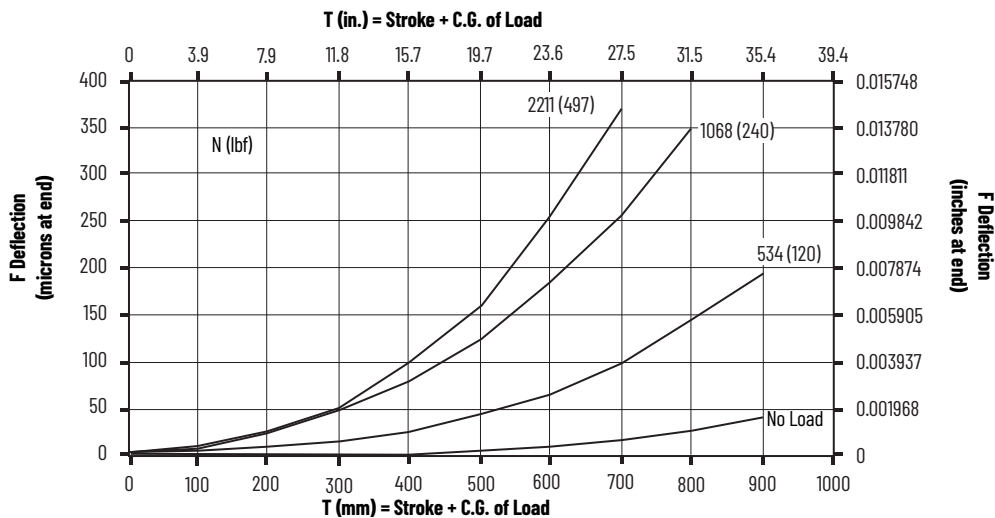

Maximum Pitch and Yaw Moment

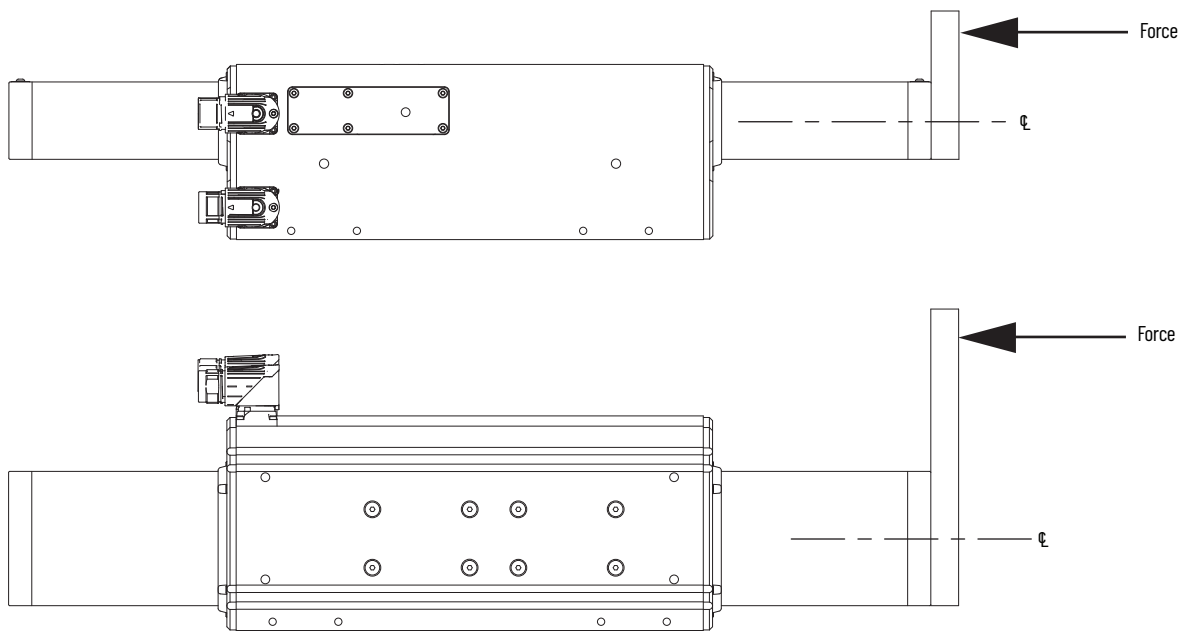

End Cap Maximum Mounting Moment

Linear Thruster Cat. No.	Frame Size	Value, max N·m (lb·ft)
LDAT-S03xxxx	30	27.50 (20.0)
LDAT-S05xxxx	50	47.50 (35.0)
LDAT-S07xxxx	70	102.38 (76.0)
LDAT-S10xxxx	100	102.38 (75.5)
LDAT-S15xxxx	150	102.38 (75.5)

Maximum Torsional Moment

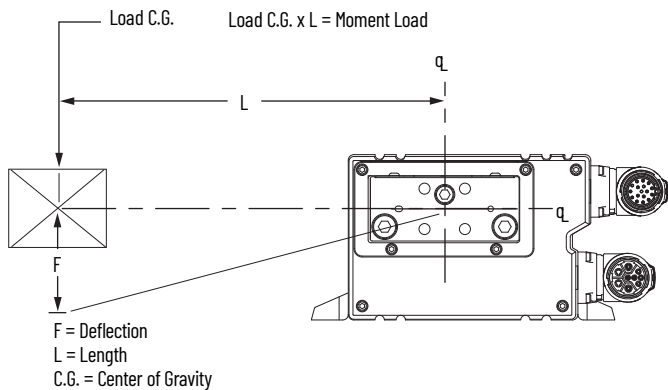

Maximum Twist

Linear Thruster Cat. No.	Frame Size	Value, max N·m (lb·in)
LDAT-S03xxxx	30	18.6 (165)
LDAT-S05xxxx	50	33.9 (300)
LDAT-S07xxxx	70	113 (1000)
LDAT-S10xxxx	150	226 (2000)

Performance Specifications with 200V-class Drives

Performance Specifications (Frame 30) with 200V-class Drives

Linear Thruster Cat. No.	Velocity, max 230V AC m/s	System Continuous Stall Current Amps 0-pk	System Continuous Stall Force N (lb)	System Peak Stall Current Amps 0-pk	System Peak Stall Force N (lb)	Rated Output 230V AC kW
LDAT-S031010-Dxx	2.4	4.8	81 (18)	12.2	168 (38)	0.20
LDAT-S031020-Dxx	3.1					0.25
LDAT-S031030-Dxx	3.5					0.29
LDAT-S031040-Dxx	3.8					0.31
LDAT-S032010-Dxx	3.1	7.4	126 (28)	24.3	336 (76)	0.44
LDAT-S032020-Dxx	4.1					0.52
LDAT-S032030-Dxx	4.7					0.59
LDAT-S032040-Dxx	5.0					0.63
LDAT-S032010-Exx	3.1	3.7	190 (43)	12.2	504 (113)	0.40
LDAT-S032020-Exx	4.1					0.47
LDAT-S032030-Exx	4.7					0.52
LDAT-S032040-Exx	5.0					0.55
LDAT-S033010-Dxx	3.5	11.1	190 (43)	36.5	504 (113)	0.67
LDAT-S033020-Dxx	4.7					0.88
LDAT-S033030-Dxx	5.0					0.95
LDAT-S033040-Dxx						0.95
LDAT-S033010-Exx	3.5	3.7	190 (43)	12.2	504 (113)	0.55
LDAT-S033020-Exx	4.4					0.65
LDAT-S033030-Exx						0.65
LDAT-S033040-Exx						0.65

Performance Specifications (Frame 50) with 200V-class Drives

Linear Thruster Cat. No.	Velocity, max 230V AC m/s	System Continuous Stall Current Amps 0-pk	System Continuous Stall Force N (lb)	System Peak Stall Current Amps 0-pk	System Peak Stall Force N (lb)	Rated Output 230V AC kW
LDAT-S051010-Dxx	2.8	3.1	119 (27)	11.4	363 (82)	0.31
LDAT-S051020-Dxx	3.7					0.38
LDAT-S051030-Dxx	4.1					0.42
LDAT-S051040-Dxx	4.4					0.44
LDAT-S051050-Dxx	4.7					0.46
LDAT-S052010-Dxx	3.7	6.2	251 (56)	22.7	727 (163)	0.79
LDAT-S052020-Dxx	4.8					0.97
LDAT-S052030-Dxx	5.00					1.01
LDAT-S052040-Dxx						1.01
LDAT-S052050-Dxx	5.00	1.01				
LDAT-S052010-Exx	2.6	3.1	119 (27)	11.4	363 (82)	0.50
LDAT-S052050-Exx						0.50
LDAT-S053010-Dxx	4.1	9.4	378 (85)	34.2	1093 (246)	1.31
LDAT-S053020-Dxx	5.0					1.53
LDAT-S053030-Dxx	5.0					1.53
LDAT-S053050-Dxx						1.53
LDAT-S053010-Exx	1.7	3.1	119 (27)	11.4	363 (82)	0.47
LDAT-S053050-Exx						0.47

Performance Specifications (Frame 50) with 200V-class Drives (continued)

Linear Thruster Cat. No.	Velocity, max 230V AC m/s	System Continuous Stall Current Amps 0-pk	System Continuous Stall Force N (lb)	System Peak Stall Current Amps 0-pk	System Peak Stall Force N (lb)	Rated Output 230V AC kW
LDAT-S054010-Dxx	4.4	12.4	509 (114)	45.5	1453 (327)	1.87
LDAT-S054020-Dxx ... LDAT-S054050-Dxx	5.0					2.05
LDAT-S054010-Exx ... LDAT-S054050-Exx	2.6	6.2		22.7		1.02

Performance Specifications (Frame 70) with 200V-class Drives

Linear Thruster Cat. No.	Velocity, max 230V AC m/s	System Continuous Stall Current Amps 0-pk	System Continuous Stall Force N (lb)	System Peak Stall Current Amps 0-pk	System Peak Stall Force N (lb)	Rated Output 230V AC kW
LDAT-S072010-Dxx ... LDAT-S072070-Dxx	3.5	6.0	364 (82)	22.0	1055 (237)	1.03
LDAT-S072010-Exx ... LDAT-S072070-Exx	1.7	3.0		11.0		0.47
LDAT-S073010-Dxx ... LDAT-S073070-Dxx	3.5	9.0	554 (125)	32.8	1576 (354)	1.57
LDAT-S073010-Exx ... LDAT-S073070-Exx	1.2	3.0		10.9		0.41
LDAT-S074010-Dxx ... LDAT-S074070-Dxx	3.5	11.9	730 (164)	43.5	2088 (469)	2.08
LDAT-S074010-Exx ... LDAT-S074070-Exx	1.8	6.0		21.7		0.95
LDAT-S076010-Dxx ... LDAT-S076070-Dxx	3.5	18.2	1122 (252)	66.4	3189 (717)	3.17
LDAT-S076010-Exx ... LDAT-S076070-Exx	1.8	9.1		33.2		1.45

Performance Specifications (Frame 100) with 200V-class Drives

Linear Thruster Cat. No.	Velocity, max 230V AC m/s	System Continuous Stall Current Amps 0-pk	System Continuous Stall Force N (lb)	System Peak Stall Current Amps 0-pk	System Peak Stall Force N (lb)	Rated Output 230V AC kW
LDAT-S102010-Dxx ... LDAT-S102090-Dxx	2.6	5.7	456 (103)	21.0	1289 (290)	0.96
LDAT-S102010-Exx ... LDAT-S102090-Exx	1.3	2.9		10.5		0.42
LDAT-S103010-Dxx ... LDAT-S103090-Dxx	2.7	8.6	702 (158)	31.5	1935 (435)	1.47
LDAT-S103010-Exx ... LDAT-S103090-Exx	0.9	2.9		10.5		0.30
LDAT-S104010-Dxx ... LDAT-S104090-Dxx	2.7	11.5	929 (209)	42.0	2578 (580)	2.07
LDAT-S104010-Exx ... LDAT-S104090-Exx	1.3	5.7		21.0		0.86
LDAT-S106010-Dxx ... LDAT-S106090-Dxx	2.7	17.3	1403 (315)	63.0	3871 (870)	2.94
LDAT-S106010-Exx ... LDAT-S106090-Exx	1.3	8.6		31.5		1.28

Performance Specifications (Frame 150) with 200V-class Drives

Linear Thruster Cat. No.	Velocity, max 230V AC m/s	System Continuous Stall Current Amps 0-pk	System Continuous Stall Force N (lb)	System Peak Stall Current Amps 0-pk	System Peak Stall Force N (lb)	Rated Output 230V AC kW
LDAT-S152010-Dxx ... LDAT-S152090-Dxx	1.8	5.3	643 (145)	19.5	1799 (404)	0.87
LDAT-S152010-Exx ... LDAT-S152090-Exx	0.9	2.7		9.8	1679 (377)	0.34
LDAT-S153010-Dxx ... LDAT-S153090-Dxx	1.8	8.0	978 (220)	29.1	2680 (602)	1.33
LDAT-S154010-Dxx ... LDAT-S154090-Dxx	1.8	10.7	1306 (294)	39.1	3597 (809)	1.78
LDAT-S154010-Exx ... LDAT-S154090-Exx	0.9	5.3		19.5	3383 (761)	0.70
LDAT-S156010-Dxx ... LDAT-S156090-Dxx	1.8	16.3	1997 (449)	59.4	5469 (1229)	2.71
LDAT-S156010-Exx ... LDAT-S156090-Ex	0.9	8.1		19.8	5110 (1149)	1.05

Performance Specifications with 400V-class Drives

Performance Specifications (Frame 30) with 400V-class (three-phase) Drives

Linear Thruster Cat. No.	Velocity, max 460V AC m/s	System Continuous Stall Current Amps 0-pk	System Continuous Stall Force N (lb)	System Peak Stall Current Amps 0-pk	System Peak Stall Force N (lb)	Rated Output 460V AC kW
LDAT-S031010-Dxx	2.4	4.8	81 (18)	12.2	168 (38)	0.20
LDAT-S031020-Dxx	3.1					0.25
LDAT-S031030-Dxx	3.5					0.29
LDAT-S031040-Dxx	3.8					0.31
LDAT-S032010-Dxx	3.1	7.4	126 (28)	24.3	336 (76)	0.40
LDAT-S032020-Dxx	4.1					0.52
LDAT-S032030-Dxx	4.7					0.59
LDAT-S032040-Dxx	5.0					0.63
LDAT-S032010-Exx	3.1	3.7	190 (43)	12.2	504 (113)	0.40
LDAT-S032020-Exx	4.1					0.52
LDAT-S032030-Exx	4.7					0.59
LDAT-S032040-Exx	5.0					0.63
LDAT-S033010-Dxx	3.5	11.1	190 (43)	36.5	504 (113)	0.67
LDAT-S033020-Dxx	4.7					0.88
LDAT-S033030-Dxx	5.0					0.95
LDAT-S033040-Dxx						0.67
LDAT-S033010-Exx	3.5	3.7	190 (43)	12.2	504 (113)	0.67
LDAT-S033020-Exx	4.7					0.87
LDAT-S033030-Exx	5.0					0.91
LDAT-S033040-Exx						0.91

Performance Specifications (Frame 50) with 400V-class (three-phase) Drives

Linear Thruster Cat. No.	Velocity, max 460V AC m/s	System Continuous Stall Current Amps 0-pk	System Continuous Stall Force N (lb)	System Peak Stall Current Amps 0-pk	System Peak Stall Force N (lb)	Rated Output 460V AC kW
LDAT-S051010-Dxx	2.8	3.1	119 (27)	11.4	363 (82)	0.34
LDAT-S051020-Dxx	3.7					0.43
LDAT-S051030-Dxx	4.1					0.49
LDAT-S051040-Dxx	4.4					0.53
LDAT-S051050-Dxx	4.7					0.55
LDAT-S052010-Dxx	3.7	6.2	251 (56)	22.7	727 (163)	0.92
LDAT-S052020-Dxx	4.8					1.20
LDAT-S052030-Dxx	5.0					1.24
LDAT-S052040-Dxx						1.24
LDAT-S052050-Dxx						1.24
LDAT-S052010-Exx	3.7	3.1	378 (85)	11.4	1093 (246)	0.80
LDAT-S052020-Exx	4.6					0.98
LDAT-S052030-Exx	4.6					1.02
LDAT-S052040-Exx						1.02
LDAT-S052050-Exx						1.02
LDAT-S053010-Dxx	4.1	9.4	378 (85)	34.2	1093 (246)	1.56
LDAT-S053020-Dxx	5.0					1.87
LDAT-S053030-Dxx						1.87
LDAT-S053050-Dxx						1.87
LDAT-S053010-Exx	3.5					3.1
LDAT-S054010-Dxx	4.4	12.4	509 (114)	45.5	1453 (327)	2.26
LDAT-S054020-Dxx	5.00					2.53
LDAT-S054050-Dxx						2.53
LDAT-S054010-Exx						4.4
LDAT-S054020-Exx	5.0					6.2
LDAT-S054050-Exx	5.0	6.2	22.7	2.05		

Performance Specifications (Frame 70) with 400V-class (three-phase) Drives

Linear Thruster Cat. No.	Velocity, max 460V AC m/s	System Continuous Stall Current Amps 0-pk	System Continuous Stall Force N (lb)	System Peak Stall Current Amps 0-pk	System Peak Stall Force N (lb)	Rated Output 460V AC kW		
LDAT-S072010-Dxx	3.9	6.0	364 (82)	22.0	1055 (237)	1.37		
LDAT-S072020-Dxx	5.0					1.64		
LDAT-S072030-Dxx						1.64		
LDAT-S072070-Dxx						1.64		
LDAT-S072010-Exx	3.5					3.0	11.0	1.03
LDAT-S073010-Dxx	4.4	9.0	554 (125)	32.8	1576 (354)	2.27		
LDAT-S073020-Dxx	5.0					2.50		
LDAT-S073070-Dxx						2.50		
LDAT-S073010-Exx						2.4	3.0	10.9
LDAT-S073070-Exx	2.4					3.0	10.9	1.01

Performance Specifications (Frame 70) with 400V-class (three-phase) Drives (continued)

Linear Thruster Cat. No.	Velocity, max 460V AC m/s	System Continuous Stall Current Amps 0-pk	System Continuous Stall Force N (lb)	System Peak Stall Current Amps 0-pk	System Peak Stall Force N (lb)	Rated Output 460V AC kW
LDAT-S074010-Dxx	4.7	11.9	730 (164)	43.5	2088 (469)	3.15
LDAT-S074020-Dxx ... LDAT-S074070-Dxx	5.0					3.30
LDAT-S074010-Exx ... LDAT-S074070-Exx	3.5			6.0		21.7
LDAT-S076010-Dxx ... LDAT-S076070-Dxx	5.0	18.2	1122 (252)	66.4	3189 (717)	5.02
LDAT-S076010-Exx ... LDAT-S076070-Exx	3.5	9.1		33.2		3.18

Performance Specifications (Frame 100) with 400V-class (three-phase) Drives

Linear Thruster Cat. No.	Velocity, max 460V AC m/s	System Continuous Stall Current Amps 0-pk	System Continuous Stall Force N (lb)	System Peak Stall Current Amps 0-pk	System Peak Stall Force N (lb)	Rated Output 460V AC kW
LDAT-S102010-Dxx	3.4	5.7	456 (103)	21.0	1289 (290)	1.44
LDAT-S102020-Dxx	4.4					1.74
LDAT-S102030-Dxx ... LDAT-S102040-Dxx ... LDAT-S102050-Dxx ... LDAT-S102090-Dxx	5.0					1.91
LDAT-S102010-Exx ... LDAT-S102090-Exx	2.6			2.9		10.5
LDAT-S103010-Dxx	3.8	8.6	702 (158)	31.5	1935 (435)	2.41
LDAT-S103020-Dxx ... LDAT-S103090-Dxx	5.0					2.93
LDAT-S103010-Exx ... LDAT-S103090-Exx	1.8			2.9		10.5
LDAT-S104010-Dxx	4.1	11.5	929 (209)	42.0	2578 (580)	3.76
LDAT-S104020-Dxx ... LDAT-S104090-Dxx	5.0					4.29
LDAT-S104010-Exx ... LDAT-S104090-Exx	2.7			5.7		21.0
LDAT-S106010-Dxx	4.5	17.3	1403 (315)	63.0	3871 (870)	5.41
LDAT-S106020-Dxx ... LDAT-S106090-Dxx	5.0					5.87
LDAT-S106010-Exx ... LDAT-S106090-Exx	2.7			8.6		31.5

Performance Specifications (Frame 150) with 400V-class (three-phase) Drives

Linear Thruster Cat. No.	Velocity, max 460V AC m/s	System Continuous Stall Current Amps 0-pk	System Continuous Stall Force N (lb)	System Peak Stall Current Amps 0-pk	System Peak Stall Force N (lb)	Rated Output 460V AC kW
LDAT-S152010-Dxx	3.2	5.3	643 (145)	19.5	1799 (404)	1.76
LDAT-S152020-Dxx ... LDAT-S152090-Dxx	3.5					1.89
LDAT-S152010-Exx	1.8	2.7	978 (220)	9.8	2680 (602)	0.87
LDAT-S152090-Exx		8.0		29.1		2.87
LDAT-S153010-Dxx	3.6	2.7	978 (220)	9.1	2680 (602)	0.80
LDAT-S153090-Dxx	1.2					
LDAT-S154010-Dxx	3.5	5.3	1306 (294)	19.5	3597 (809)	1.78
LDAT-S154090-Dxx	1.8					
LDAT-S156010-Dxx	3.6	8.1	1997 (449)	19.8	5469 (1229)	2.71
LDAT-S156090-Dxx	1.8					

Weight Specifications

Kinetix LDAT Integrated Linear Thrusters (Frame 30)

Linear Thruster Cat. No.	Weight, approx kg (lb)
LDAT-S031010-xxx	6.9 (15.2)
LDAT-S031020-xxx	7.5 (16.6)
LDAT-S031030-xxx	8.1 (17.9)
LDAT-S031040-xxx	8.7 (19.2)

Linear Thruster Cat. No.	Weight, approx kg (lb)
LDAT-S032010-xxx	9.7 (21.5)
LDAT-S032020-xxx	10.3 (22.8)
LDAT-S032030-xxx	10.9 (24.1)
LDAT-S032040-xxx	11.6 (25.5)

Linear Thruster Cat. No.	Weight, approx kg (lb)
LDAT-S033010-xxx	12.6 (26.9)
LDAT-S033020-xxx	13.2 (30.4)
LDAT-S033030-xxx	13.8 (31.7)
LDAT-S033040-xxx	14.4 (31.7)

Kinetix LDAT Integrated Linear Thrusters (Frame 50)

Linear Thruster Cat. No.	Weight, approx kg (lb)
LDAT-S051010-xxx	10.3 (22.7)
LDAT-S051020-xxx	11.3 (24.8)
LDAT-S051030-xxx	12.2 (26.9)
LDAT-S051040-xxx	13.2 (29.0)
LDAT-S051050-xxx	14.1 (31.7)
LDAT-S052010-xxx	14.6 (32.2)
LDAT-S052020-xxx	15.6 (34.3)

Linear Thruster Cat. No.	Weight, approx kg (lb)
LDAT-S052030-xxx	16.5 (36.4)
LDAT-S052040-xxx	17.5 (38.5)
LDAT-S052050-xxx	18.4 (40.6)
LDAT-S053010-xxx	18.9 (41.6)
LDAT-S053020-xxx	19.8 (43.7)
LDAT-S053030-xxx	20.8 (45.8)
LDAT-S053040-xxx	21.8 (48.0)

Linear Thruster Cat. No.	Weight, approx kg (lb)
LDAT-S053050-xxx	22.7 (50.1)
LDAT-S054010-xxx	23.3 (51.3)
LDAT-S054020-xxx	24.2 (53.4)
LDAT-S054030-xxx	25.2 (55.5)
LDAT-S054040-xxx	26.1 (57.6)
LDAT-S054050-xxx	27.1 (59.7)

Kinetix LDAT Integrated Linear Thrusters (Frame 70)

Linear Thruster Cat. No.	Weight, approx kg (lb)
LDAT-S072010-xxx	17.7 (39.1)
LDAT-S072020-xxx	18.9 (41.8)
LDAT-S072030-xxx	20.2 (44.4)
LDAT-S072040-xxx	21.4 (47.1)
LDAT-S072050-xxx	22.6 (49.8)
LDAT-S072060-xxx	23.8 (52.2)
LDAT-S072070-xxx	25.0 (55.2)
LDAT-S073010-xxx	23.0 (50.7)
LDAT-S073020-xxx	24.2 (53.3)
LDAT-S073030-xxx	25.4 (56.0)

Linear Thruster Cat. No.	Weight, approx kg (lb)
LDAT-S073040-xxx	26.6 (58.7)
LDAT-S073050-xxx	27.8 (61.4)
LDAT-S073060-xxx	29.1 (64.1)
LDAT-S073070-xxx	28.2 (62.1)
LDAT-S074010-xxx	30.3 (66.8)
LDAT-S074020-xxx	29.4 (64.8)
LDAT-S074030-xxx	30.6 (67.5)
LDAT-S074040-xxx	31.8 (70.2)
LDAT-S074050-xxx	33.1 (72.9)
LDAT-S074060-xxx	34.3 (75.6)

Linear Thruster Cat. No.	Weight, approx kg (lb)
LDAT-S074070-xxx	35.5 (78.2)
LDAT-S076010-xxx	38.6 (85.1)
LDAT-S076020-xxx	39.8 (87.7)
LDAT-S076030-xxx	41.0 (90.4)
LDAT-S076040-xxx	42.2 (93.1)
LDAT-S076050-xxx	43.5 (95.8)
LDAT-S076060-xxx	44.7 (98.5)
LDAT-S076070-xxx	45.9 (101.2)

Kinetix LDAT Integrated Linear Thrusters (Frame 100)

Linear Thruster Cat. No.	Weight, approx kg (lb)
LDAT-S102010-xxx	27.9 (61.5)
LDAT-S102020-xxx	29.9 (65.8)
LDAT-S102030-xxx	31.9 (70.2)
LDAT-S102040-xxx	33.8 (74.6)
LDAT-S102050-xxx	35.8 (79.0)
LDAT-S102060-xxx	37.8 (83.4)
LDAT-S102070-xxx	39.8 (87.7)
LDAT-S102080-xxx	41.8 (92.1)
LDAT-S102090-xxx	43.8 (96.9)
LDAT-S103010-xxx	36.0 (79.4)
LDAT-S103020-xxx	38.0 (83.8)
LDAT-S103030-xxx	40.0 (88.1)

Linear Thruster Cat. No.	Weight, approx kg (lb)
LDAT-S103040-xxx	42.0 (92.1)
LDAT-S103050-xxx	44.0 (96.9)
LDAT-S103060-xxx	45.9 (101.3)
LDAT-S103070-xxx	47.9 (105.6)
LDAT-S102080-xxx	49.9 (110.0)
LDAT-S102090-xxx	51.9 (114.4)
LDAT-S104010-xxx	44.1 (97.3)
LDAT-S104020-xxx	46.1 (101.7)
LDAT-S104030-xxx	48.1 (106.1)
LDAT-S104040-xxx	50.1 (110.4)
LDAT-S104050-xxx	52.1 (114.8)
LDAT-S104060-xxx	54.1 (119.2)

Linear Thruster Cat. No.	Weight, approx kg (lb)
LDAT-S104070-xxx	56.0 (123.3)
LDAT-S104080-xxx	58.0 (127.9)
LDAT-S104090-xxx	60.0 (132.3)
LDAT-S106010-xxx	60.2 (132.7)
LDAT-S106020-xxx	62.2 (137.1)
LDAT-S106030-xxx	64.2 (141.5)
LDAT-S106040-xxx	66.1 (145.8)
LDAT-S106050-xxx	68.1 (150.2)
LDAT-S106060-xxx	70.1 (154.6)
LDAT-S106070-xxx	72.1 (159.0)
LDAT-S106080-xxx	74.1 (163.3)
LDAT-S106090-xxx	76.1 (167.7)

Kinetix LDAT Integrated Linear Thrusters (Frame 150)

Linear Thruster Cat. No.	Weight, approx kg (lb)
LDAT-S152010-xxx	38.6 (85.1)
LDAT-S152020-xxx	41.6 (91.7)
LDAT-S152030-xxx	44.6 (98.4)
LDAT-S152040-xxx	47.7 (105.1)
LDAT-S152050-xxx	50.7 (111.8)
LDAT-S152060-xxx	53.7 (118.5)
LDAT-S152070-xxx	56.8 (125.2)
LDAT-S152080-xxx	59.8 (131.9)
LDAT-S152090-xxx	62.9 (138.6)
LDAT-S153010-xxx	49.5 (109.2)
LDAT-S153020-xxx	52.6 (115.9)
LDAT-S153030-xxx	55.6 (122.6)

Linear Thruster Cat. No.	Weight, approx kg (lb)
LDAT-S153040-xxx	58.6 (129.2)
LDAT-S153050-xxx	61.7 (135.9)
LDAT-S153060-xxx	64.7 (142.6)
LDAT-S153070-xxx	67.7 (149.3)
LDAT-S152080-xxx	70.8 (156.0)
LDAT-S152090-xxx	73.8 (162.7)
LDAT-S154010-xxx	60.4 (133.2)
LDAT-S154020-xxx	63.4 (139.9)
LDAT-S154030-xxx	66.5 (146.6)
LDAT-S154040-xxx	69.5 (153.3)
LDAT-S154050-xxx	72.5 (159.9)
LDAT-S154060-xxx	75.6 (166.6)

Linear Thruster Cat. No.	Weight, approx kg (lb)
LDAT-S154070-xxx	78.6 (173.3)
LDAT-S154080-xxx	81.7 (180.0)
LDAT-S154090-xxx	84.7 (186.7)
LDAT-S156010-xxx	82.4 (181.7)
LDAT-S156020-xxx	85.5 (188.4)
LDAT-S156030-xxx	88.5 (195.1)
LDAT-S156040-xxx	91.5 (201.8)
LDAT-S156050-xxx	94.6 (208.5)
LDAT-S156060-xxx	97.6 (215.1)
LDAT-S156070-xxx	100.6 (221.8)
LDAT-S156080-xxx	103.7 (228.5)
LDAT-S156090-xxx	106.7 (235.2)

Kinetix LDAT Integrated Linear Thrusters Mounting Accessories

Accessory Item		Frame	Cat. No.	Weight, approx g (oz)
1	Foot Mount	30	LDAT-SMID-FTMOUNT	30 (1.06)
		50		
		70		
		100	LDAT-SLARGE-FTMOUNT	
		150		
2	Clevis, Male	30	LDAT-03-CLVSM	100 (3.53)
		50	LDAT-0507-CLVSM	150 (5.29)
		70		
		100	LDAT-1015-CLVSM	370 (13.05)
		150		

Accessory Item		Frame	Cat. No.	Weight, approx g (oz)
3	Clevis, Female	30	LDAT-03-CLVSF	75 (2.65)
		50	LDAT-0507-CLVSF	100 (3.53)
		70		
		100	LDAT-1015-CLVSF	250 (8.82)
		150		

Kinetix LDAT Integrated Linear Thrusters Slider-end Accessories

Accessory Item		Frame	Cat. No.	Weight, approx g (oz)
4	Rod Clevis Kit	30	LDAT-S03-RODCLVS	190 (6.70)
		50	LDAT-S0507-RODCLVS	320 (11.29)
		70		
		100	LDAT-S015-RODCLVS	770 (27.16)
		150		
5	Rod Eye Kit	30	LDAT-S03-RODEYE	150 (5.29)
		50	LDAT-S0507-RODEYE	260 (9.17)
		70		
		100	LDAT-S1015-RODEYE	590 (20.81)
		150		
6	Rod Coupler Kit	30	LDAT-S03-RODCPLR	290 (10.05)
		50	LDAT-S0507-RODCPLR	370 (13.05)
		70		
		100	LDAT-S1015-RODCPLR	1030 (36.33)
		150		

Accessory Item		Frame	Cat. No.	Weight, approx g (oz)
7	Horizontal Payload Mounting Bracket	30	LDAT-S03-HPBRKT	260 (9.17)
		50	LDAT-S0507-HPBRKT	430 (15.17)
		70		
		100	LDAT-S10-HPBRKT	910 (32.10)
		150	LDAT-S15-HPBRKT	1300 (54.86)
8	Counterbalance Kit	30	LDAT-S03-CBRKT	380 (13.4)
		50	LDAT-S0507-CBRKT	600 (21.2)
		70		
		100	LDAT-S10-CBRKT	950 (33.5)
		150	LDAT-S15-CBRKT	1160 (40.9)

Dimensions - Kinetix LDAT Integrated Linear Thrusters

Kinetix LDAT Integrated Linear Thrusters Dimensions (Frame 30)

Bottom View of Side Mounting

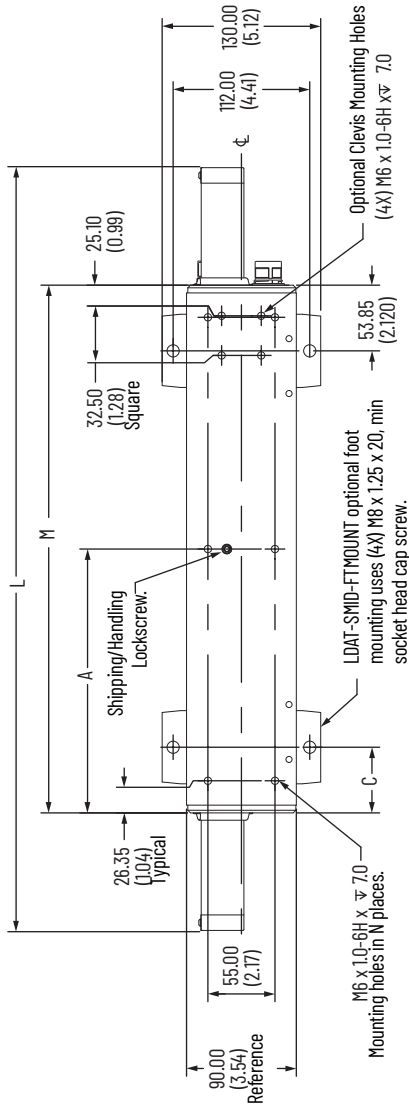

Bottom View of Bottom Mounting

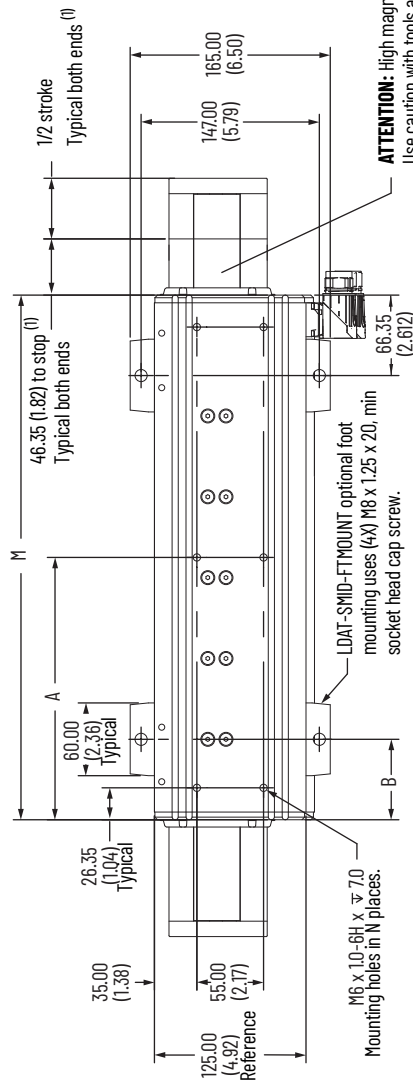

(1) Up to approximately 5 mm (0.2 in.) overtravel at each end. An additional 12.7 (0.5 in.) overtravel at each end when stop is fully compressed in a crash condition.

End View of Bottom Mounting

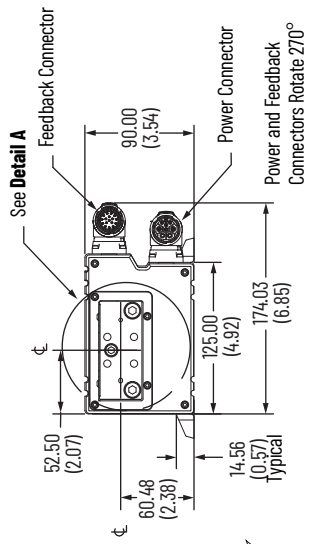

Dimensions are in mm (in.)

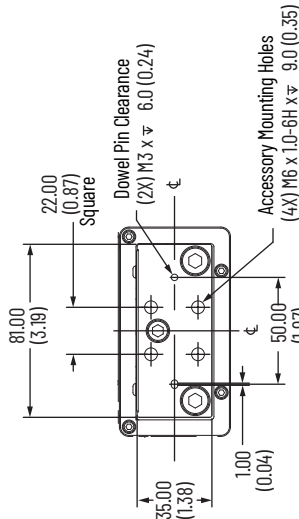

Detail A

Slider-end Mounting
Typical Both Ends

ATTENTION: High magnetic field.
Use caution with tools and loose hardware.
Pacemaker wearers: maintain 300 mm (12 in.) distance.

Kinetix LDAT Integrated Linear Thruster Dimensions (Frame 30)

Linear Thruster Cat. No.	Motor size (reference)	Stroke mm (in.)	L mm (in.)	M mm (in.)	A mm (in.)	B mm (in.)	C mm (in.)	N
LDAT-S031010-xxx	100	100 (3.9)	425.4 (16.75)	232.70 (9.161)		51.35 (2.022)	38.85 (1.530)	4
LDAT-S031020-xxx		200 (7.9)	525.4 (20.69)					
LDAT-S031030-xxx		300 (11.8)	625.4 (24.62)					
LDAT-S031040-xxx		400 (15.7)	725.4 (28.56)					
LDAT-S032010-xxx	200	100 (3.9)	525.4 (20.69)	332.70 (13.098)		66.35 (2.612)	53.85 (2.120)	
LDAT-S032020-xxx		200 (7.9)	625.4 (24.62)					
LDAT-S032030-xxx		300 (11.8)	725.4 (28.56)					
LDAT-S032040-xxx		400 (15.7)	825.4 (32.50)					
LDAT-S033010-xxx	300	100 (3.9)	625.4 (24.62)	432.70 (17.035)	216.35 (8.518)			6
LDAT-S033020-xxx		200 (7.9)	725.4 (28.56)					
LDAT-S033030-xxx		300 (11.8)	825.4 (32.50)					
LDAT-S033040-xxx		400 (15.7)	925.4 (36.43)					

Actuators are designed to metric dimensions. Inch dimensions are approximate conversions from millimeters. Dimensions without tolerances are for reference.

Kinetix LDAT Integrated Linear Thruster Dimensions (Frame 50 and 70)

Bottom View of Side Mounting

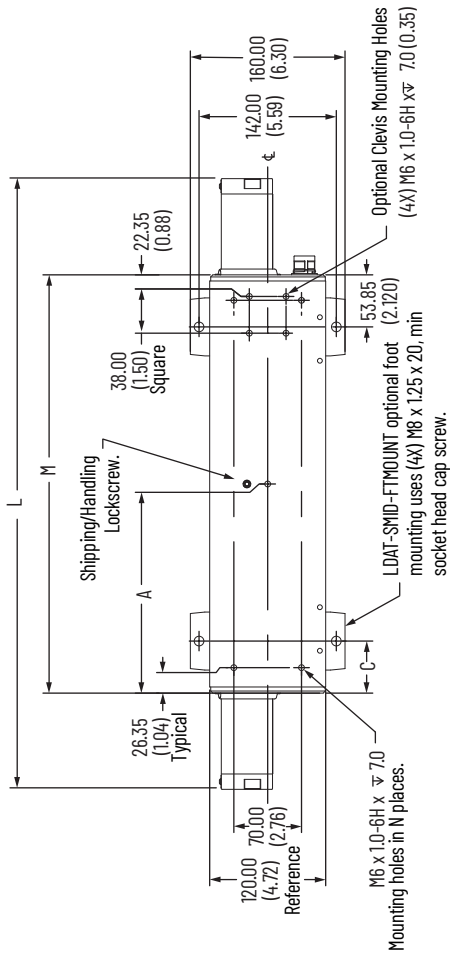

Bottom View of Bottom Mounting

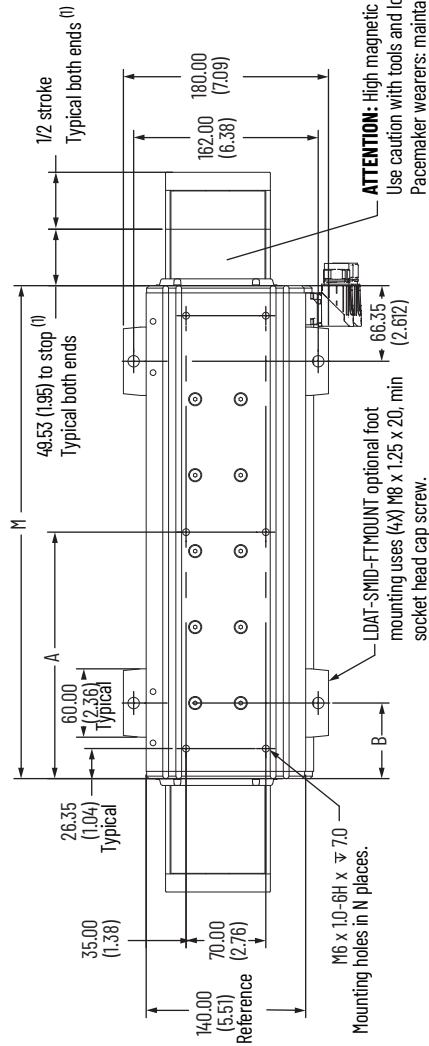

(1) Up to approximately 5 mm (0.2 in.) overtravel at each end. An additional 12.7 (0.5 in.) overtravel at each end when stop is fully compressed in a crash condition.

End View of Bottom Mounting

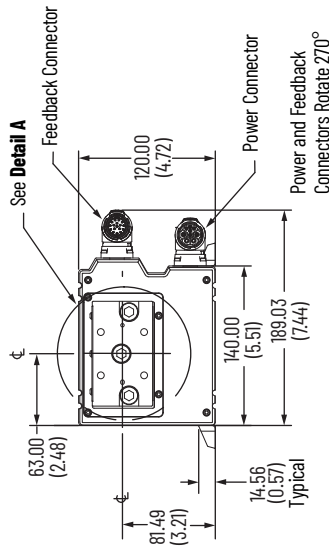

Dimensions are in mm (in.)

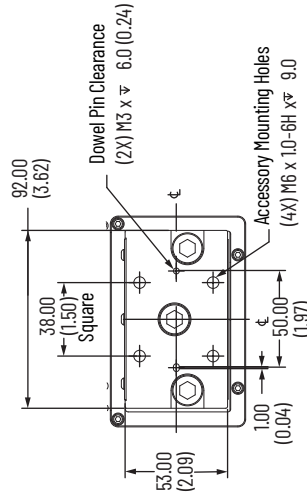

Detail A
Slider-end Mounting
Typical Both Ends

ATTENTION: High magnetic field. Use caution with tools and loose hardware. Pacemaker wearers: maintain 300 mm (12 in.) distance.

Kinetix LDAT Integrated Linear Thruster Dimensions (Frame 50)

Linear Thruster Cat. No.	Motor size (reference)	Stroke mm (in.)	L mm (in.)	M mm (in.)	A mm (in.)	B mm (in.)	C mm (in.)	N
LDAT-S051010-xxx		100 (3.9)	431.8 (16.988)					
LDAT-S051020-xxx		200 (7.9)	531.8 (20.935)			51.35 (2.022)	38.85 (1.530)	
LDAT-S051030-xxx	100	300 (11.8)	631.8 (24.872)	232.70 (9.161)				
LDAT-S051040-xxx		400 (15.7)	731.8 (28.809)					
LDAT-S051050-xxx		500 (19.7)	831.8 (32.746)					4
LDAT-S052010-xxx		100 (3.9)	531.8 (20.935)					
LDAT-S052020-xxx		200 (7.9)	631.8 (24.872)					
LDAT-S052030-xxx	200	300 (11.8)	731.8 (28.809)	332.70 (13.088)				
LDAT-S052040-xxx		400 (15.7)	831.8 (32.746)					
LDAT-S052050-xxx		500 (19.7)	931.8 (36.683)					
LDAT-S053010-xxx		100 (3.9)	631.8 (24.872)					
LDAT-S053020-xxx		200 (7.9)	731.8 (28.809)					
LDAT-S053030-xxx	300	300 (11.8)	831.8 (32.746)	432.70 (17.035)	216.35 (8.518)	66.35 (2.612)	53.85 (2.120)	
LDAT-S053040-xxx		400 (15.7)	931.8 (36.683)					
LDAT-S053050-xxx		500 (19.7)	1031.8 (40.620)					5
LDAT-S054010-xxx		100 (3.9)	731.8 (28.809)					
LDAT-S054020-xxx		200 (7.9)	831.8 (32.746)					
LDAT-S054030-xxx	400	300 (11.8)	931.8 (36.683)	532.70 (20.972)	266.35 (10.486)			
LDAT-S054040-xxx		400 (15.7)	1031.8 (40.620)					
LDAT-S054050-xxx		500 (19.7)	1131.8 (44.557)					

Kinetix LDAT Integrated Linear Thruster Dimensions (Frame 70)

Linear Thruster Cat. No.	Motor size (reference)	Stroke mm (in.)	L mm (in.)	M mm (in.)	A mm (in.)	B mm (in.)	C mm (in.)	N
LDAT-S072010-xxx		100 (3.9)	531.8 (20.94)					
LDAT-S072020-xxx		200 (7.9)	631.8 (24.87)					
LDAT-S072030-xxx		300 (11.8)	731.8 (28.81)					
LDAT-S072040-xxx	200	400 (15.7)	831.8 (32.75)	332.70 (13.088)				4
LDAT-S072050-xxx		500 (19.7)	931.8 (36.68)					
LDAT-S072060-xxx		600 (23.6)	1031.8 (40.62)					
LDAT-S072070-xxx		700 (27.6)	1131.8 (44.56)					
LDAT-S073010-xxx		100 (3.9)	631.8 (24.87)					
LDAT-S073020-xxx		200 (7.9)	731.8 (28.81)					
LDAT-S073030-xxx		300 (11.8)	831.8 (32.75)					
LDAT-S073040-xxx	300	400 (15.7)	931.8 (36.68)	432.70 (17.035)	216.35 (8.52)			
LDAT-S073050-xxx		500 (19.7)	1031.8 (40.62)					
LDAT-S073060-xxx		600 (23.6)	1131.8 (44.56)					
LDAT-S073070-xxx		700 (27.6)	1231.8 (48.48)					
LDAT-S074010-xxx		100 (3.9)	731.8 (28.81)					
LDAT-S074020-xxx		200 (7.9)	831.8 (32.75)					
LDAT-S074030-xxx		300 (11.8)	931.8 (36.68)					
LDAT-S074040-xxx	400	400 (15.7)	1031.8 (40.62)	532.70 (20.97)	266.350 (10.49)			5
LDAT-S074050-xxx		500 (19.7)	1131.8 (44.56)					
LDAT-S074060-xxx		600 (23.6)	1231.8 (48.48)					
LDAT-S074070-xxx		700 (27.6)	1331.8 (52.43)					
LDAT-S076010-xxx		100 (3.9)	931.8 (36.68)					
LDAT-S076020-xxx		200 (7.9)	1031.8 (40.62)					
LDAT-S076030-xxx		300 (11.8)	1131.8 (44.56)					
LDAT-S076040-xxx	600	400 (15.7)	1231.8 (48.48)	732.70 (28.85)	366.350 (14.42)			
LDAT-S076050-xxx		500 (19.7)	1331.8 (52.43)					
LDAT-S076060-xxx		600 (23.6)	1431.8 (56.37)					
LDAT-S076070-xxx		700 (27.6)	1531.8 (60.31)					

Actuators are designed to metric dimensions. Inch dimensions are approximate conversions from millimeters. Dimensions without tolerances are for reference.

Kinetix LDAT Integrated Linear Thruster Dimensions (Frame 100)

Bottom View of Side Mounting

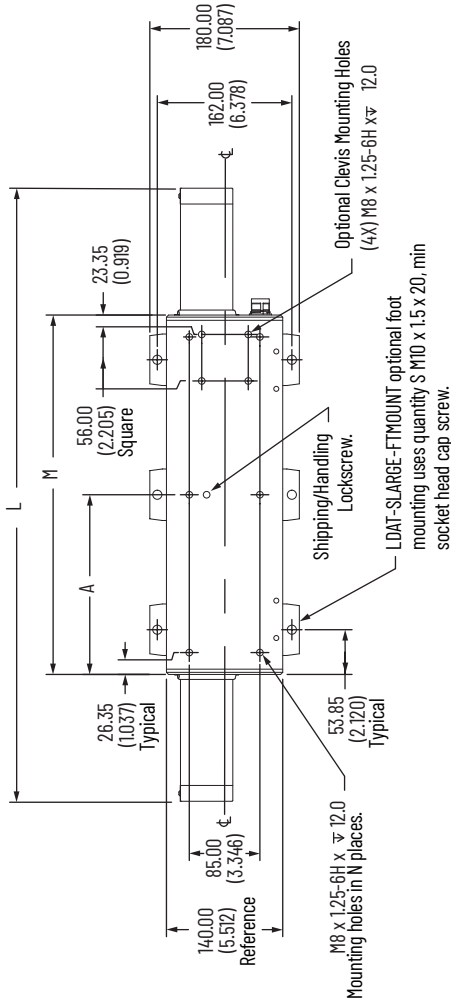

Bottom View of Bottom Mounting

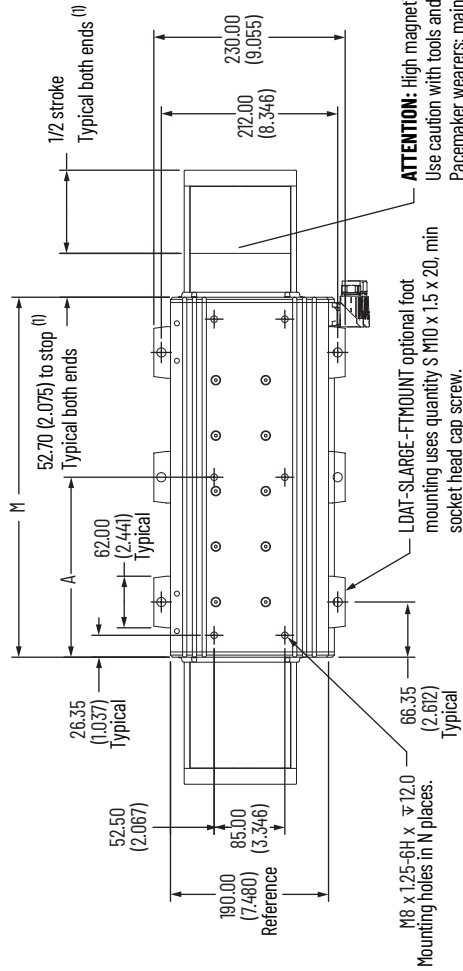

End View of Bottom Mounting

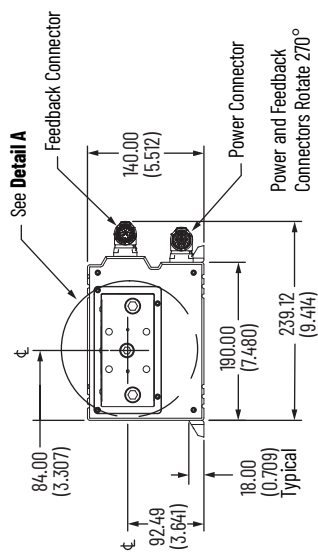

Dimensions are in mm (in.)

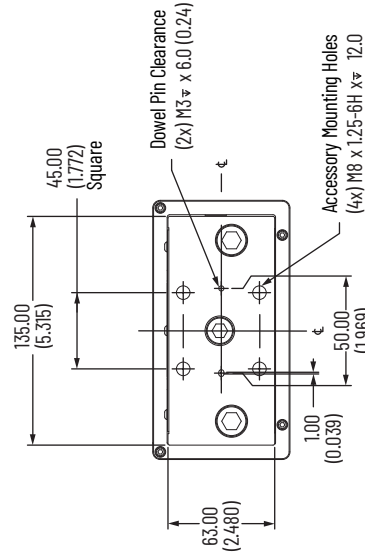

Detail A
Slider-end Mounting
Typical Both Ends

(1) Up to approximately 5 mm (0.2 in.) overtravel at each end. An additional 12.7 (0.5 in.) overtravel at each end when stop is fully compressed in a crash condition.

Kinetix LDAT Integrated Linear Thruster Dimensions (Frame 100)

Linear Thruster Cat. No.	Motor size (reference)	Stroke mm (in.)	L mm (in.)	M mm (in.)	A mm (in.)	N	S
LDAT-S102010-xxx	200	100 (3.9)	538.1 (21.18)	332.70 (13.098)	-	4	4
LDAT-S102020-xxx		200 (7.9)	638.1 (25.12)				
LDAT-S102030-xxx		300 (11.8)	738.1 (29.06)				
LDAT-S102040-xxx		400 (15.7)	838.1 (33.00)				
LDAT-S102050-xxx		500 (19.7)	938.1 (36.93)				
LDAT-S102060-xxx		600 (23.6)	1038.1 (40.87)				
LDAT-S102070-xxx		700 (27.6)	1138.1 (44.81)				
LDAT-S102080-xxx		800 (31.5)	1238.1 (48.74)				
LDAT-S102090-xxx		900 (35.4)	1338.1 (52.68)				
LDAT-S103010-xxx	300	100 (3.9)	638.1 (25.12)	432.70 (17.035)	216.35 (8.518)	6	4
LDAT-S103020-xxx		200 (7.9)	738.1 (29.06)				
LDAT-S103030-xxx		300 (11.8)	838.1 (33.00)				
LDAT-S103040-xxx		400 (15.7)	938.1 (36.93)				
LDAT-S103050-xxx		500 (19.7)	1038.1 (40.87)				
LDAT-S103060-xxx		600 (23.6)	1138.1 (44.81)				
LDAT-S103070-xxx		700 (27.6)	1238.1 (48.74)				
LDAT-S102080-xxx		800 (31.5)	1338.1 (52.68)				
LDAT-S102090-xxx		900 (35.4)	1438.1 (56.62)				
LDAT-S104010-xxx	400	100 (3.9)	738.1 (29.06)	532.70 (20.972)	266.35 (10.486)	6	6
LDAT-S104020-xxx		200 (7.9)	838.1 (33.00)				
LDAT-S104030-xxx		300 (11.8)	938.1 (36.93)				
LDAT-S104040-xxx		400 (15.7)	1038.1 (40.87)				
LDAT-S104050-xxx		500 (19.7)	1138.1 (44.81)				
LDAT-S104060-xxx		600 (23.6)	1238.1 (48.74)				
LDAT-S104070-xxx		700 (27.6)	1338.1 (52.68)				
LDAT-S104080-xxx		800 (31.5)	1438.1 (56.62)				
LDAT-S104090-xxx		900 (35.4)	1538.1 (60.55)				
LDAT-S106010-xxx	600	100 (3.9)	938.1 (36.93)	732.70 (28.846)	366.35 (14.423)	6	6
LDAT-S106020-xxx		200 (7.9)	1038.1 (40.87)				
LDAT-S106030-xxx		300 (11.8)	1138.1 (44.81)				
LDAT-S106040-xxx		400 (15.7)	1238.1 (48.74)				
LDAT-S106050-xxx		500 (19.7)	1338.1 (52.68)				
LDAT-S106060-xxx		600 (23.6)	1438.1 (56.62)				
LDAT-S106070-xxx		700 (27.6)	1538.1 (60.55)				
LDAT-S106080-xxx		800 (31.5)	1638.1 (64.49)				
LDAT-S106090-xxx		900 (35.4)	1738.1 (68.43)				

Actuators are designed to metric dimensions. Inch dimensions are approximate conversions from millimeters. Dimensions without tolerances are for reference.

Kinetix LDAT Integrated Linear Thruster Dimensions (Frame 150)

Bottom View of Side Mounting

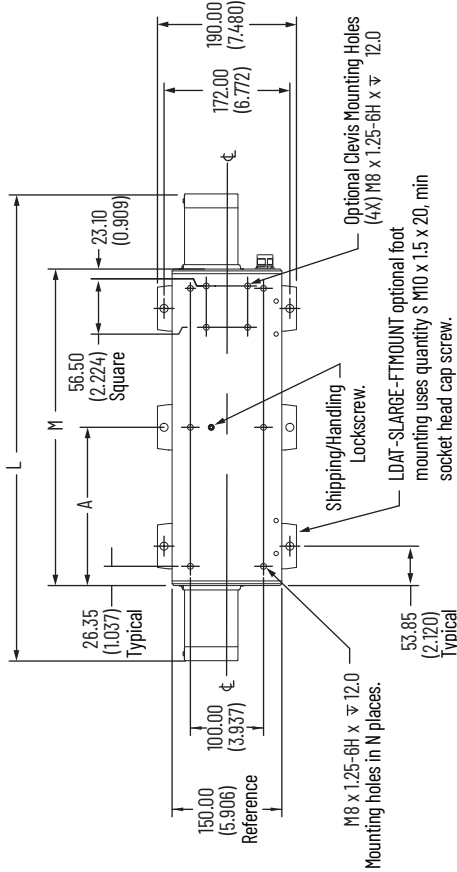

Bottom View of Bottom Mounting

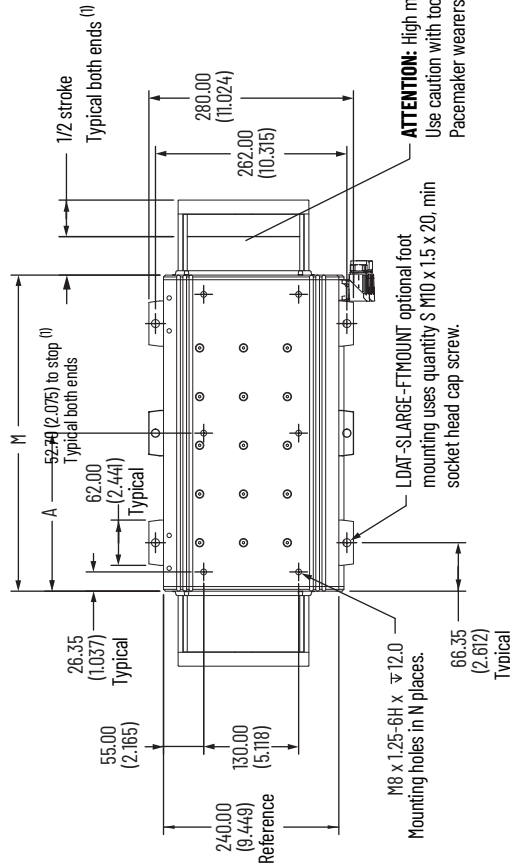

End View of Bottom Mounting

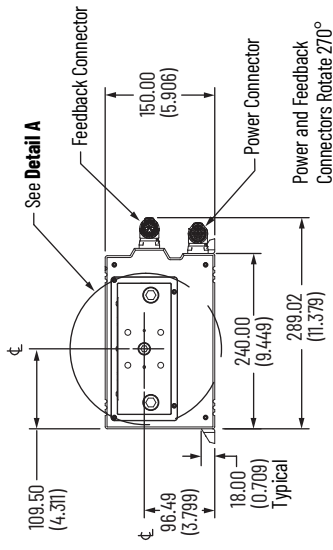

Dimensions are in mm (in.)

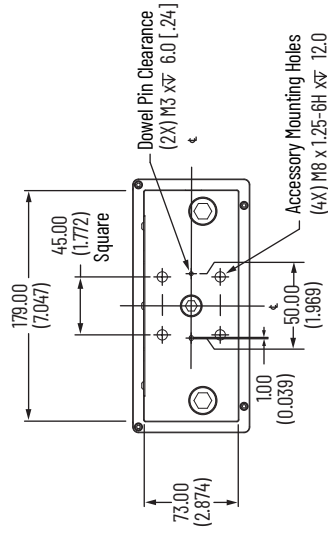

Detail A

Slider-end Mounting
Typical Both Ends

(1) Up to approximately 5 mm (0.2 in.) overtravel at each end. An additional 12.7 (0.5 in.) overtravel at each end when stop is fully compressed in a crash condition.

Kinetix LDAT Integrated Linear Thruster Dimensions (Frame 150)

Linear Thruster Cat. No.	Motor size (reference)	Stroke mm (in.)	L mm (in.)	M mm (in.)	A mm (in.)	N	S
LDAT-S152010-xxx	200	100 (3.9)	538.1 (21.18)	332.70 (13.098)	-	4	4
LDAT-S152020-xxx		200 (7.9)	638.1 (25.12)				
LDAT-S152030-xxx		300 (11.8)	738.1 (29.06)				
LDAT-S152040-xxx		400 (15.7)	838.1 (33.00)				
LDAT-S152050-xxx		500 (19.7)	938.1 (36.93)				
LDAT-S152060-xxx		600 (23.6)	1038.1 (40.87)				
LDAT-S152070-xxx		700 (27.6)	1138.1 (44.81)				
LDAT-S152080-xxx		800 (31.5)	1238.1 (48.74)				
LDAT-S152090-xxx		900 (35.4)	1338.1 (52.68)				
LDAT-S153010-xxx		300	100 (3.9)				
LDAT-S153020-xxx	200 (7.9)		738.1 (29.06)				
LDAT-S153030-xxx	300 (11.8)		838.1 (33.00)				
LDAT-S153040-xxx	400 (15.7)		938.1 (36.93)				
LDAT-S153050-xxx	500 (19.7)		1038.1 (40.87)				
LDAT-S153060-xxx	600 (23.6)		1138.1 (44.81)				
LDAT-S153070-xxx	700 (27.6)		1238.1 (48.74)				
LDAT-S153080-xxx	800 (31.5)		1338.1 (52.68)				
LDAT-S153090-xxx	900 (35.4)		1438.1 (56.62)				
LDAT-S154010-xxx	400		100 (3.9)	738.1 (29.06)	532.70 (20.972)	266.35 (10.486)	6
LDAT-S154020-xxx		200 (7.9)	838.1 (33.00)				
LDAT-S154030-xxx		300 (11.8)	938.1 (36.93)				
LDAT-S154040-xxx		400 (15.7)	1038.1 (40.87)				
LDAT-S154050-xxx		500 (19.7)	1138.1 (44.81)				
LDAT-S154060-xxx		600 (23.6)	1238.1 (48.74)				
LDAT-S154070-xxx		700 (27.6)	1338.1 (52.68)				
LDAT-S154080-xxx		800 (31.5)	1438.1 (56.62)				
LDAT-S154090-xxx		900 (35.4)	1538.1 (60.55)				
LDAT-S156010-xxx		600	100 (3.9)	938.1 (36.93)			
LDAT-S156020-xxx	200 (7.9)		1038.1 (40.87)				
LDAT-S156030-xxx	300 (11.8)		1138.1 (44.81)				
LDAT-S156040-xxx	400 (15.7)		1238.1 (48.74)				
LDAT-S156050-xxx	500 (19.7)		1338.1 (52.68)				
LDAT-S156060-xxx	600 (23.6)		1438.1 (56.62)				
LDAT-S156070-xxx	700 (27.6)		1538.1 (60.55)				
LDAT-S156080-xxx	800 (31.5)		1638.1 (64.49)				
LDAT-S156090-xxx	900 (35.4)		1738.1 (68.43)				

Actuators are designed to metric dimensions. Inch dimensions are approximate conversions from millimeters. Dimensions without tolerances are for reference.

Kinetix LDAT Integrated Linear Thrusters Mounting Accessories

These accessories apply to Kinetix LDAT linear thrusters. Components are designed to metric dimensions. Inch dimensions are approximate conversions from millimeters. Dimensions without tolerances are for reference.

Foot Mount Bracket Kit

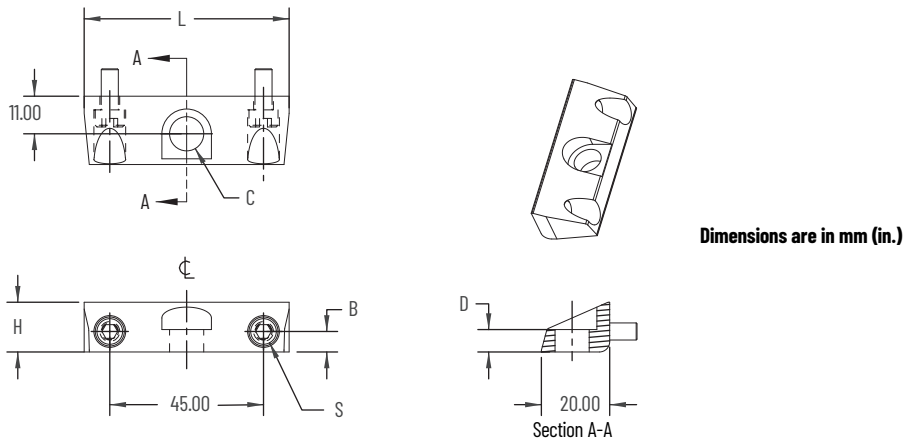

Cat. No. ⁽¹⁾	Frame	L mm (in.)	H mm (in.)	B mm (in.)	C, min mm (in.)	D mm (in.)	S mm (in.)	Kit Includes ⁽²⁾
LDAT-SMID-FTMOUNT	30	60.0 (2.36)	14.6 (0.57)	6.0 (0.24)	M8 x 1.25 x 20	6.56 (0.26)	M5 x 0.8 x 12	<ul style="list-style-type: none"> • 4 foot mounts • 8 screws
	50							
	70							
LDAT-SLARGE-FTMOUNT	100	62.0 (2.44)	18.0 (0.71)	7.8 (0.31)	M10 x 1.5 x 25	6.50 (0.26)	M6 x 1.0 x 16 M6 x 1.0 x 25	<ul style="list-style-type: none"> • 2 foot mounts • 8 screws
	150							

(1) Material is black anodized 6061-T6 aluminum. Stainless steel mounting hardware is included.

(2) Catalog number LDAT-SLARGE-FTMOUNT ships with two mounting screw lengths. Use the M6 x 1.0 x 25 LG screws to mount center feet on the LDAT-S1x4xxx and LDAT-S1x6xxx thruster units.

Clevis (male) Attachment

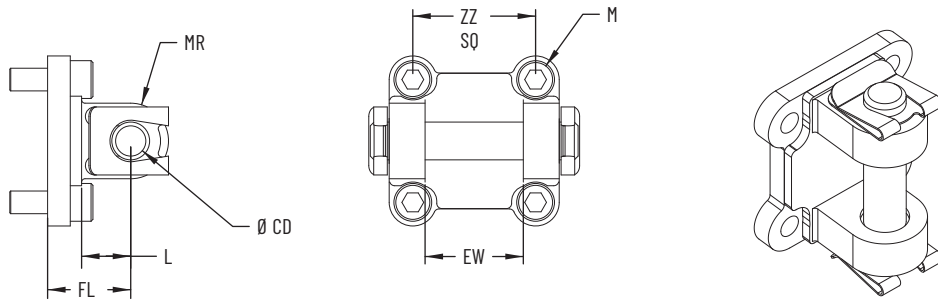

Dimensions are in mm (in.)

- Attachment includes:
- 1 Flange
 - 1 Pivot pin
 - 2 Retaining clips
 - 4 Mounting screws

Cat. No. (1)	Frame	Ø CD mm (in.) H9	EW (2) mm (in.)	FL (3) mm (in.)	L mm (in.)	MR mm (in.)	ZZ mm (in.)	M mm (in.)
LDAT-S03-CLVSM	30	10.0 (0.39)	26.0 (1.02)	22.0 (0.87)	13.0 (0.51)	8.5 (0.33)	32.5 (1.28)	M6 x 1.0 x 16 (0.04 x 0.63)
LDAT-S0507-CLVSM	50 70	12.0 (0.47)	28.0 (1.10)	25.0 (0.98)	16.0 (0.63)	12.0 (0.47)	38.0 (1.50)	
LDAT-S1015-CLVSM	100 150	16.0 (0.63)	40.0 (1.57)	32.0 (1.26)	21.0 (0.83)	16.0 (0.63)	56.5 (2.22)	M8 x 1.25 x 18 (0.05 x 0.71)

(1) Material is die cast aluminum. Contains no copper, PTFE, or silicone.
 (2) Tolerance for this dimension is a range between -0.2...-0.6 mm (-0.007...0.023 in.).
 (3) Tolerance for this dimension is ± 0.2 (± 0.008).

Clevis (Female) Attachment

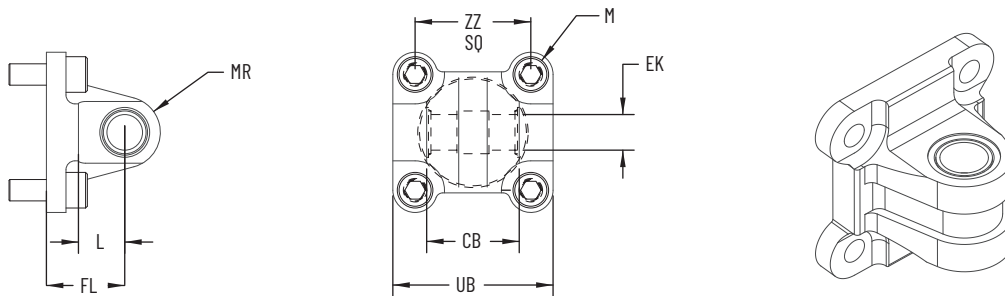

Dimensions are in mm (in.)

- Attachment includes:
- 1 Swivel flange
 - 4 mounting screws

Cat. No. (1)	Frame	CB mm (in.) H14	Ø EK mm (in.) e8	FL(2) mm (in.)	L mm (in.)	MR mm (in.)	UB mm (in.) h14	ZZ mm (in.)	M mm (in.)
LDAT-S03-CLVSF	30	26.0 (1.02)	10.0 (0.39)	22.0 (0.87)	13.0 (0.51)	8.5 (0.33)	45.0 (1.8)	32.5 (1.28)	M6 x 1.0 x 16
LDAT-S0507-CLVSF	50 70	28.0 (1.10)	12.0 (0.47)	25.0 (0.98)	16.0 (0.63)	12.0 (0.47)	52.0 (2.1)	38.0 (1.50)	M6 x 1.0 x 16
LDAT-S1015-CLVSF	100 150	40.0 (1.57)	16.0 (0.63)	32.0 (1.26)	21.0 (0.83)	16.0 (0.63)	70.0 (2.8)	56.5 (2.22)	M8 x 1.25 x 18

(1) Material is die cast aluminum. Contains no copper, PTFE, or silicone.
 (2) Tolerance for this dimension is ± 0.2 (± 0.008).

Kinetix LDAT Linear Thruster Slider-end Accessories

These accessories apply to Kinetix LDAT linear thrusters. Components are designed to metric dimensions. Inch dimensions are approximate conversion from millimeters. Dimensions with tolerances are for reference.

Rod Eye Attachment

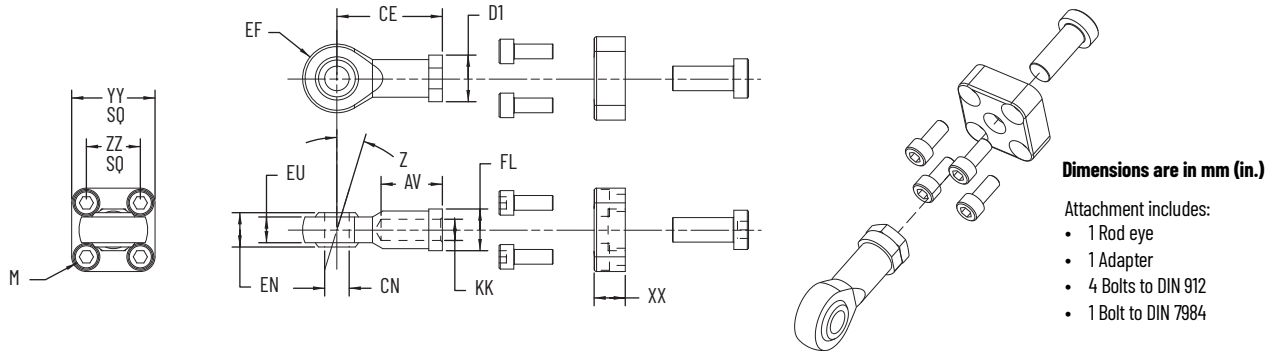

Cat. No. ⁽¹⁾	Frame	KK	AV ⁽²⁾ mm (in.)	CE mm (in.)	Ø CN mm (in.) H7	Ø D1 mm (in.)	EF ⁽³⁾ mm (in.)	EN mm (in.)	EU mm (in.)	Z Angle
LDAT-S03-RODEYE	30	M10 x 1.25	20.0 (0.79)	43.0 (1.69)	10.0 (0.39)	19.0 (0.75)	14.0 (0.55)	14.0 (0.55)	10.5 (0.41)	13°
LDAT-S0507-RODEYE	50 70	M12 x 1.25	22.0 (0.87)	50.0 (1.97)	12.0 (0.47)	22.0 (0.87)	16.0 (0.63)	16.0 (0.63)	12.0 (0.47)	
LDAT-S1015-RODEYE	100 150	M16 x 1.5	28.0 (1.10)	64.0 (2.52)	16.0 (0.63)	27.0 (1.06)	21.0 (0.83)	21.0 (0.83)	15.0 (0.59)	15°

(1) Material is galvanized steel.

(2) Tolerance for this dimension is -2.0 mm (-0.079 in.).

(3) Tolerance for this dimension is ±0.5 mm (±0.020 in.).

Cat. No. ⁽¹⁾	Frame	FL mm ⌀	XX mm (in.)	YY mm (in.)	ZZ mm (in.)	M
LDAT-S03-RODEYE	30	17.0	12.7 (0.50)	34.0 (1.34)	22.0 (0.86)	M6 x 1.0 x14
LDAT-S0507-RODEYE	50 70	19.0	15.875 (0.6)	50.0 (1.97)	38.0 (1.49)	M6 x 1.0 x 16
LDAT-S1015-RODEYE	100 150	22.0	25.4 (1.0)	62.0 (2.44)	45.0 (1.77)	M8 x 1.25 x 25

(1) Material is galvanized steel.

Rod Clevis Kit

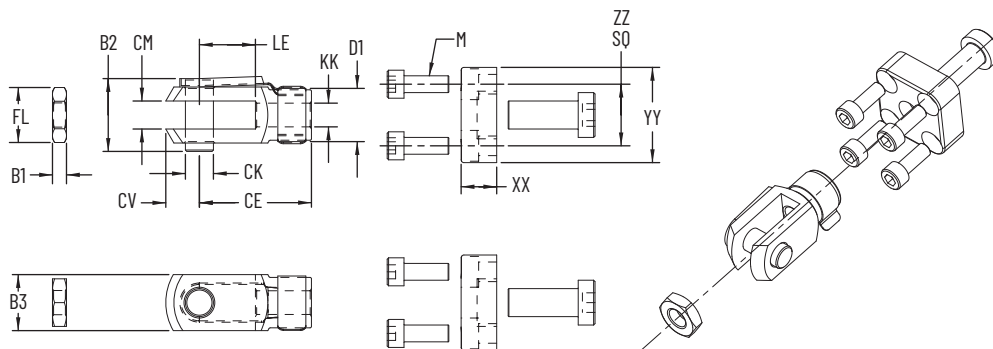

Dimensions are in mm (in.)

- Attachment includes:
- 1 Rod clevis
 - 1 Adapter
 - 1 Hinged spring pin
 - 4 Bolts to DIN 912
 - 1 Bolt to DIN 7984
 - 1 Hex nut

Cat. No. ⁽¹⁾	Frame	KK	B1 mm (in.)	B2 mm (in.)	B3 mm (in.)	CE ⁽²⁾ mm (in.)	Ø CK mm (in.) H11	CM mm (in.)	CV mm (in.)	Ø D1 mm (in.)	LE ⁽³⁾ mm (in.)
LDAT-S03-RODCLVS	30	M10 x 1.25	5.0 (0.20)	26.0 (1.02)	20.0 (0.79)	40.0 (1.57)	10.0 (0.39)	10.0 ⁽⁴⁾ (0.39)	12.0 (0.47)	18.0 (0.71)	20.0 (0.79)
LDAT-S0507-RODCLVS	50	M12 x 1.25	6.0 (0.24)	31.1 (1.22)	24.0 (0.94)	48.0 (1.89)	12.0 (0.47)	12.0 ⁽⁵⁾ (0.47)	14.0 (0.55)	20.0 (0.79)	24.0 (0.94)
	70										
LDAT-S1015-RODCLVS	100	M16 x 1.25	8.0 (0.31)	39.5 (1.56)	32.0 (1.26)	64.0 (2.52)	16.0 (0.63)	16.0 ⁽⁵⁾ (0.63)	19.0 (0.75)	26.0 (1.02)	32.0 (1.26)
	150										

(1) Material is galvanized steel. Contains no copper, PTFE, or silicone.
 (2) The tolerance for this dimension is ±0.4 (±0.016).
 (3) The tolerance for this dimension is ±0.5 (±0.020).
 (4) The tolerance for this dimension is B13.
 (5) Tolerance for this dimension is a range between +0.7...+0.15 mm (+0.027...0.006 in.).

Cat. No. ⁽¹⁾	Frame	FL mm ±C	XX mm (in.)	YY mm (in.)	ZZ mm (in.)	M
LDAT-S03-RODCLVS	30	17.0	12.7 (0.50)	34.0 (1.34)	22.0 (0.87)	M6 x 1.0 x 14
LDAT-S0507-RODCLVS	50	19.0	15.875 (0.6)	50.0 (1.97)	38.0 (1.50)	M6 x 1.0 x 16
	70					
LDAT-S1015-RODCLVS	100	24.0	25.4 (1.00)	62.0 (2.44)	45.0 (1.77)	M8 x 1.25 x 25
	150					

(1) Material is galvanized steel. Contains no copper, PTFE, or silicone.

Rod Coupler Kit

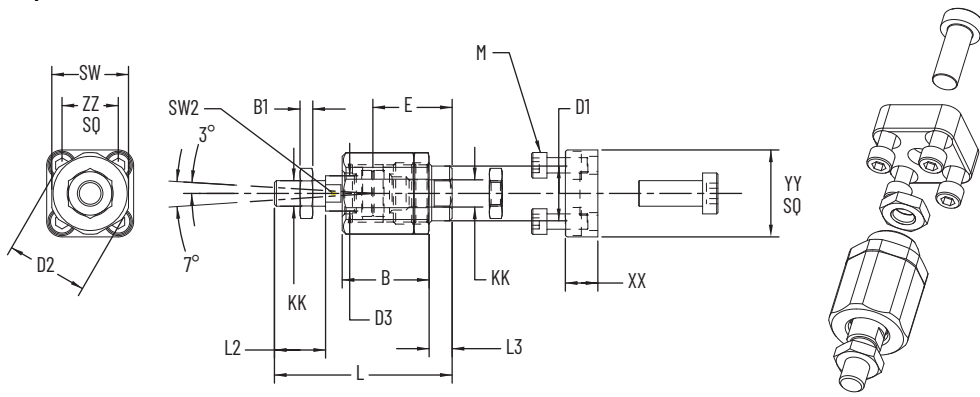

Dimensions are in mm (in.)

Attachment includes:

- 1 Self-aligning rod coupler
- 1 Adapter
- 4 Bolts to DIN 912
- 1 Bolt to DIN 7984
- 1 Hex nut

Cat. No. (1)	Frame	KK	B mm (in.)	B1 mm (in.)	D1 mm (in.)	D2 mm (in.)	D3 mm (in.)	E mm (in.)	L mm (in.)	L2 mm (in.)	L3 mm (in.)	SW mm (in.)	SW2 mm
LDAT-S03-RODCPLR	30	M10 x 1.25	34.0 (1.34)	5.0 (0.20)	21.8 (0.86)	32.0 (1.26)	14.0 (0.55)	31.0 (1.22)	69.5 (2.74)	20.0 (0.79)	8.0 (0.31)	30.0 (1.18)	12
LDAT-S0507-RODCPLR	50 70	M12 x 1.25		6.0 (0.24)				32.0 (1.26)	74.5 (2.93)	24.0 (0.94)	9.0 (0.35)		
LDAT-S1015-RODCPLR	100 150	M16 x 1.15	53.0 (2.09)	8.0 (0.31)	33.8 (1.33)	45.0 (1.77)	22.0 (0.87)	44.5 (1.75)	103.0 (4.06)	32.0 (1.26)		41.0 (1.61)	

Cat. No. (1)	Frame	XX mm (in.)	YY mm (in.)	ZZ mm (in.)	M	Radial Deviation mm (in.)
LDAT-S03-RODCPLR	30	12.7 (0.50)	34 (1.34)	22.0 (0.87)	M6 x 1.0 x 14	± 0.7 (0.028)
LDAT-S0507-RODCPLR	50 70	15.9 (0.63)	50 (1.97)	38.0 (1.50)	M6 x 1.0 x 16	
LDAT-S1015-RODCPLR	100 150	25.4 (1.00)	62 (2.44)	45.0 (1.77)	M8 x 1.25 x 25	± 1.0 (0.039)

(1) Material is galvanized steel. Contains no copper, PTFE, or silicone.

Payload Bracket Attachment

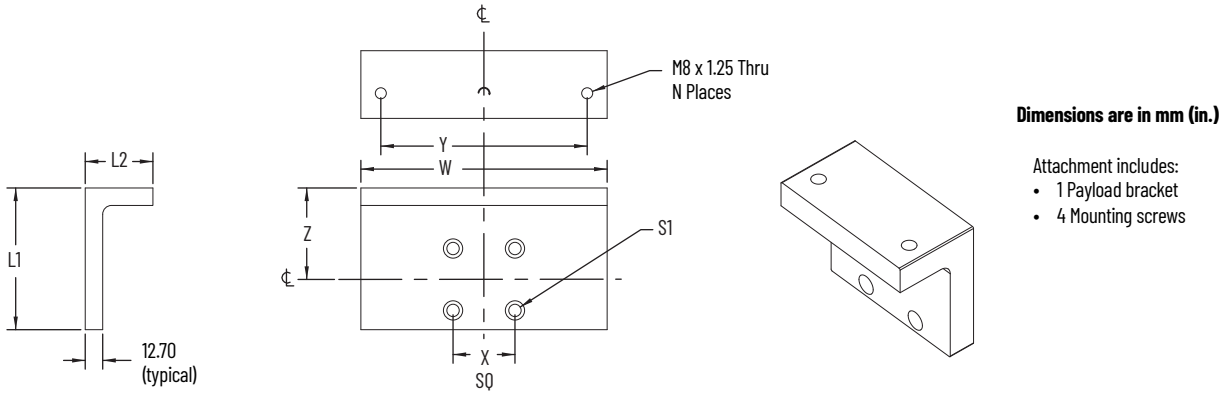

Cat. No. (1)	Frame	L1 mm (in.)	L2 mm (in.)	W mm (in.)	X mm (in.)	Y mm (in.)	Z mm (in.)	N	S1 mm
LDAT-S03-HPBRKT	30	60.0 (2.36)	51.9 (2.04)	81.0 (3.18)	22.0 (0.86)	60.0 (2.36)	42.5 (1.67)	2	M6 x 1.0 x 14
LDAT-S0507-HPBRKT	50 70	78.0 (3.07)	55.6 (2.18)	92.0 (3.62)	38.0 (1.50)	70.0 (2.76)	51.5 (2.03)	2	
LDAT-S10-HPBRKT	100	93.0 (3.66)	49.20 (1.94)	135.0 (5.31)	45.0 (1.77)	100.0 (3.94)	61.5 (2.42)	2	M8 x 1.25 x 14
LDAT-S15-HPBRKT	150	103.0 (4.06)		179.0 (7.04)		150.0 (5.91)	66.5 (2.62)	3	

(1) Material is black anodized 6061-T6 aluminum.

Counter Balance Kit

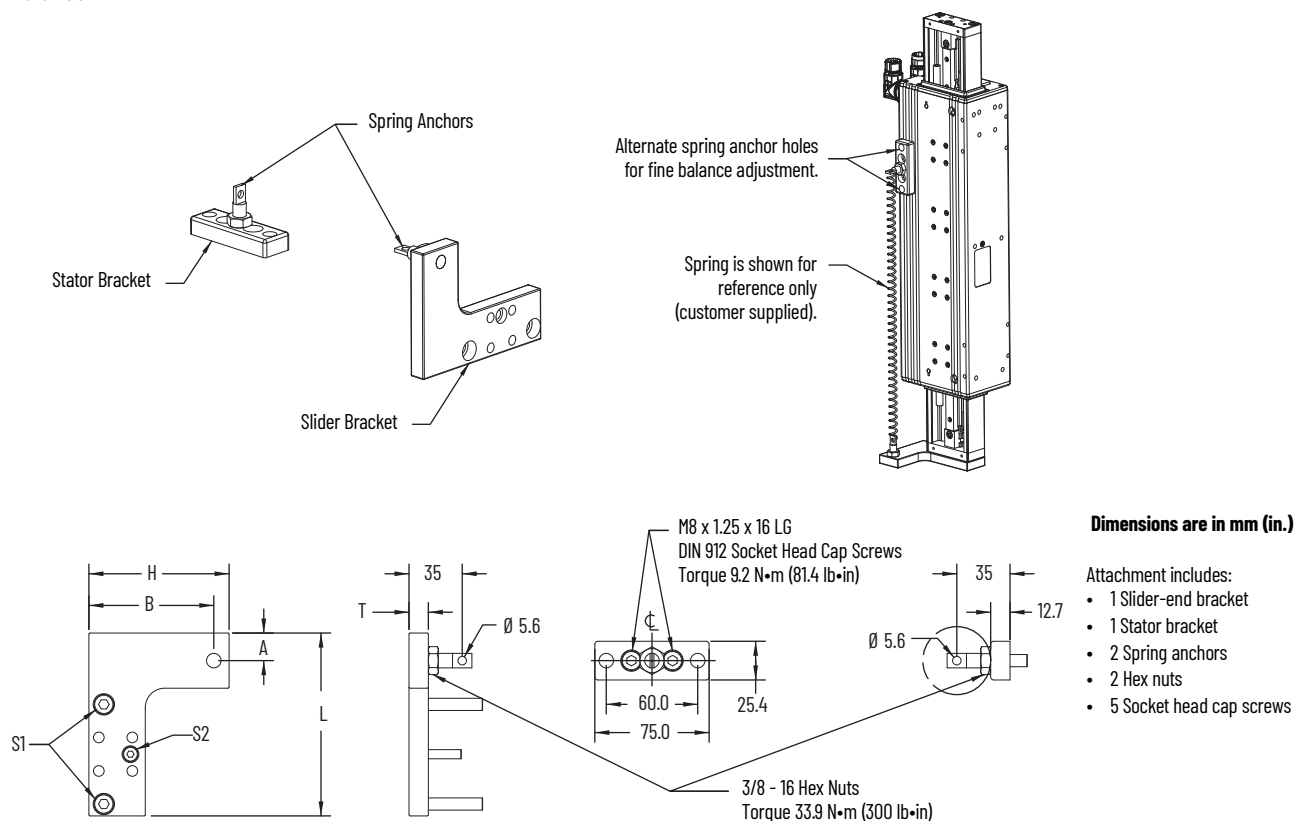

Cat. No. (1)	Frame	L mm (in.)	H mm (in.)	A mm (in.)	B mm (in.)	T mm (in.)	S1 mm	S2 mm	Moving Weight kg (lb)
LDAT-S03-CBKIT	30	120.0 (4.72)	92.0 (3.62)	18.1 (0.71)	82.0 (3.23)	12.7 (0.50)	M8 x 1.25 x 40	M6 x 1.0 x 30	0.27 (0.595)
LDAT-S0507-CBKIT	50	130.0 (5.12)	110.0 (4.33)	16.6 (0.65)	99.9 (3.923)	15.9 (0.63)	M10 x 1.5 x 50	M10 x 1.5 x 30	0.49 (1.080)
	70								
LDAT-S10-CBKIT	100	175.0 (6.89)	125.0 (4.92)	18.5 (0.73)	114.8 (4.52)	19.1 (0.75)	M12 x 1.75 x 60	M10 x 1.5 x 30	0.84 (1.852)
LDAT-S15-CBKIT	150	220.0 (8.66)	135.0 (5.31)	19.8 (0.78)	124.9 (4.92)		M14 x 2.0 x 60		1.16 (2.491)

(1) Material is black anodized 6061-T6 aluminum.

Kinetix MPAS Integrated Linear Stages



Kinetix MPAS linear stages extend the performance and reliability of Kinetix MP servo motor technology to ballscrew and direct-drive linear slide-type actuators. Kinetix MPAS linear stages are specifically designed for abusive, high-throughput industrial automation applications instead of clean, high-accuracy lab environments. Wear items such as cable track and strip seals can be changed in minutes to minimize machine down-time. Because the Kinetix MP linear stages are provided as fully integrated motor/actuators supported by Motion Analyzer software and the Studio 5000 Logix Designer® application, the time required for mechanical design, installation, setup, and programming is dramatically reduced.

Kinetix MPAS Direct-drive Linear Stage Features

- High-performance linear motor, linear guide bearings, and 5 micron resolution linear encoder integrated into a single, compact package
- Long life due to the elimination of a mechanical transmission
- Quick-change cable track module to minimize downtime
- Available with and without cover/strip seal option
- Peak forces to 601 N (135 lb) and peak velocities to 5000 mm/s (197 in/s)
- Stroke lengths from 120...1940 mm (4.7...76.4 in.)

Kinetix MPAS Ballscrew-drive Linear Stage Features

- High performance Kinetix MP servo motor, ballscrew, and linear guide bearings integrated in to single, compact package
- Peak forces to 1212 N (273 lb) and peak velocities to 1124 mm/s (44 in/s)
- Stroke lengths from 120...1020 mm (4.7...40.2 in.)

Motor Connector/Cable Compatibility

Kinetix MPAS linear stages are equipped with SpeedTec DIN connectors. However, the incremental encoder on direct-drive linear stages requires threaded DIN (M4) feedback cables in non-flex applications. This is due to the number of conductors required for incremental encoder connections.

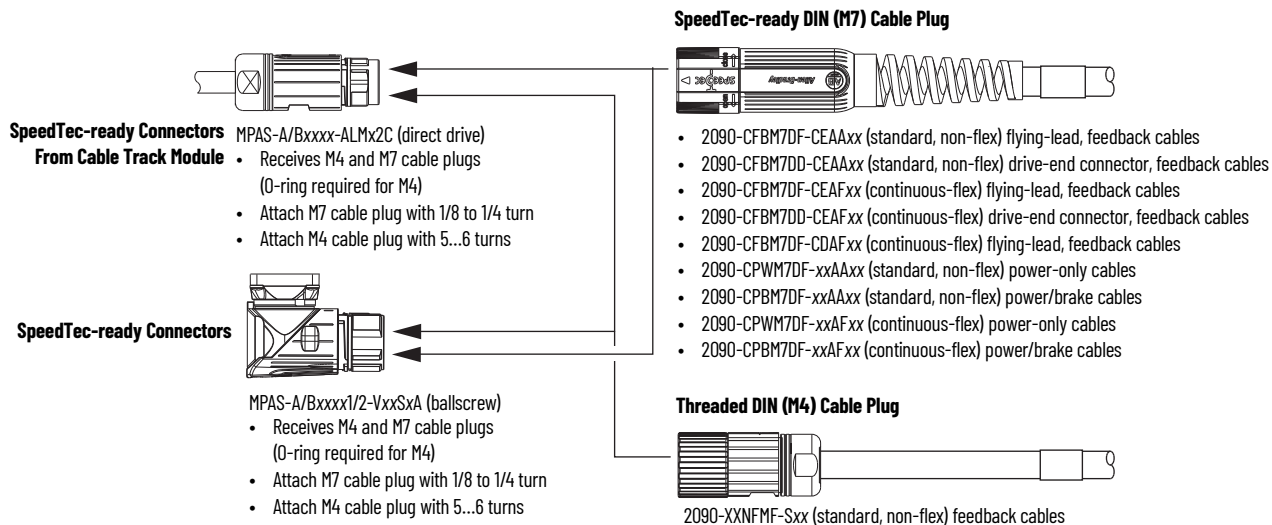

Catalog Numbers - Kinetix MPAS Integrated Linear Stages

Catalog numbers consist of various characters, each of which identifies a specific option for that component. Use the catalog numbering table chart below to understand the configuration of your actuator. For questions regarding product availability, contact your Allen-Bradley distributor.

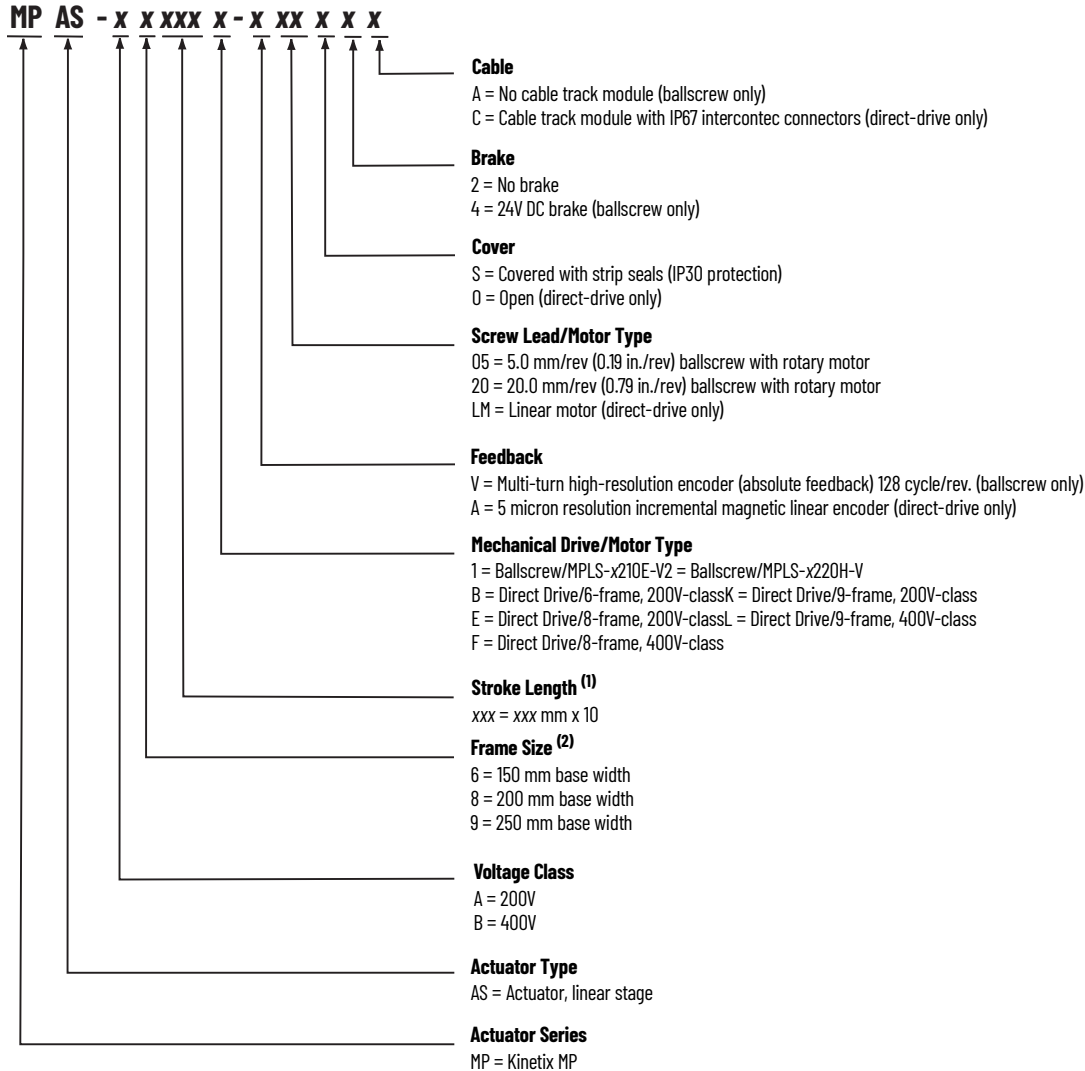

(1) For 6-frame direct-drive linear stages, variable xxx (mm stroke x 10) is 012, 018, 024, 030, 036, 042, 054, 066, 078, 090, 102, or 114.
For 8 and 9-frame direct-drive linear stages, variable xxx (mm stroke x 10) is 014, 020, 026, 032, 038, 044, 056, 068, 080, 092, 104, 128, 152, 176, or 194.
For 6-frame ballscrew linear stages, variable xxx (mm stroke x 10) is 012, 018, 024, 030, 036, 042, 054, or 066.
For 8 and 9-frame ballscrew linear stages, variable xxx (mm stroke x 10) is 012, 018, 024, 030, 036, 042, 054, 066, 078, 090, or 102.

(2) The 150 mm (6-frame) linear stages are available in ballscrew (200 and 400V-class) and direct drive (200V-class only).
The 200 mm (8-frame) linear stages are available in ballscrew and direct drive (200 and 400V-class).
The 250 mm (9-frame) linear stages are available in ballscrew and direct drive (200 and 400V-class).

Kinetix MPAS Integrated Linear Stage Accessory Kits

- Cable track module replacement kits
- Strip seal replacement kits
- Top cover kits
- Side cover kits
- Coupling kits
- Tee-nut kit (package of 10)
- Toe-clip kit (package of 10)
- Grease gun kit
- Grease replacement cartridge

Accessory Kits Common to All Single-axis Linear Stages

Linear Stage Cat. No.	Description	Accessory Cat. No.
MPAS-A/Bxxxx	Kit, grease gun for all integrated linear stages.	MPAS-GPUMP
	Grease gun refill cartridge for all integrated linear stages.	MPAS-CART
	Kit, toe clamps (10 per package) for all integrated linear stages.	MPAS-TOE
MPAS-A6xxx, MPAS-B6xxx	Kit, Tee-nuts (10 per package).	MPAS-6-TNUT
MPAS-A8xxx, MPAS-B8xxx		MPAS-8-TNUT
MPAS-A9xxx, MPAS-B9xxx		MPAS-9-TNUT

Accessory Kits for Single-axis Direct-drive Linear Stages

Linear Stage Cat. No.	Description	Accessory Cat. No.
MPAS-x6xxx-ALMx2A	Cable track module for direct-drive linear stage.	MPAS-6xxxB-CABLE ⁽¹⁾
MPAS-x8xxx-ALMx2A		MPAS-8xxxE-CABLE ⁽²⁾
MPAS-x9xxx-ALMx2A		MPAS-9xxxK-CABLE ⁽²⁾
MPAS-x6xxx-ALMS2A	Kit, strip seal for direct-drive linear stage.	MPAS-6xxxB-SEAL ⁽¹⁾
MPAS-x8xxx-ALMS2A		MPAS-8xxxE-SEAL ⁽²⁾
MPAS-x9xxx-ALMS2A		MPAS-9xxxK-SEAL ⁽²⁾
MPAS-x6xxx-ALMS2A	Kit, side covers for direct-drive linear stage.	MPAS-6xxxB-SIDE ⁽¹⁾
MPAS-x8xxx-ALMS2A		MPAS-8xxxE-SIDE ⁽²⁾
MPAS-x9xxx-ALMS2A		MPAS-9xxxK-SIDE ⁽²⁾
MPAS-x6xxx-ALMS2A	Kit, top cover for direct-drive linear stage.	MPAS-6xxxB-TOP ⁽¹⁾
MPAS-x8xxx-ALMS2A		MPAS-8xxxE-TOP ⁽²⁾
MPAS-x9xxx-ALMS2A		MPAS-9xxxK-TOP ⁽²⁾

(1) Variable xxx (mm stroke x 10) is 012, 018, 024, 030, 036, 042, 054, 066, 078, 090, 102, or 114.

(2) Variable xxx (mm stroke x 10) is 014, 020, 026, 032, 038, 044, 056, 068, 080, 092, 104, 128, 152, 176, or 194.

Accessory Kits for Single-axis Ballscrew Linear Stages

Linear Stage Cat. No.	Description	Accessory Cat. No.
MPAS-x6xxx-VxxSxA	Coupler, for ballscrew linear stage.	MPAS-6-COUP
MPAS-x8xxx-VxxSxA		MPAS-8-COUP
MPAS-x9xxx-VxxSxA		MPAS-9-COUP
MPAS-Axxxx1-V05S2A	Motor, 200V-class, without brake for 5 mm/rev ballscrew linear stage.	MPLS-A210E-V-X246
MPAS-Axxxx1-V05S4A	Motor, 200V-class, with brake for 5 mm/rev ballscrew linear stage.	MPLS-A210E-V-X247
MPAS-Bxxxx1-V05S2A	Motor, 400V-class, without brake for 5 mm/rev ballscrew linear stage.	MPLS-B210E-V-X248
MPAS-Bxxxx1-V05S4A	Motor, 400V-class, with brake for 5 mm/rev ballscrew linear stage.	MPLS-B210E-V-X249
MPAS-Axxxx2-V20S2A	Motor, 200V-class, without brake for 20 mm/rev ballscrew linear stage.	MPLS-A220H-V-X250
MPAS-Axxxx2-V20S4A	Motor, 200V-class with brake for 20 mm/rev ballscrew linear stage.	MPLS-A220H-V-X251
MPAS-Bxxxx2-V20S2A	Motor, 400V-class, without brake for 20 mm/rev ballscrew linear stage.	MPLS-B220H-V-X252
MPAS-Bxxxx2-V20S4A	Motor, 400V-class with brake for 20 mm/rev ballscrew linear stage.	MPLS-B220H-V-X253
MPAS-x6xxx-VxxSxA	Kit, strip seal for ballscrew linear stage.	MPAS-6xxx1-SEAL ⁽¹⁾
MPAS-x8xxx-VxxSxA		MPAS-8xxx1-SEAL ⁽²⁾
MPAS-x9xxx-VxxSxA		MPAS-9xxx1-SEAL ⁽²⁾
MPAS-x6xxx-VxxSxA	Kit, side cover for ballscrew linear stage.	MPAS-6xxx1-SIDE ⁽¹⁾
MPAS-x8xxx-VxxSxA		MPAS-8xxx1-SIDE ⁽²⁾
MPAS-x9xxx-VxxSxA		MPAS-9xxx1-SIDE ⁽²⁾
MPAS-x6xxx-VxxSxA	Kit, top cover for ballscrew linear stage.	MPAS-6xxx1-TOP ⁽¹⁾
MPAS-x8xxx-VxxSxA		MPAS-8xxx1-TOP ⁽²⁾
MPAS-x9xxx-VxxSxA		MPAS-9xxx1-TOP ⁽²⁾

(1) Variable xxx (mm stroke x 10) is 012, 018, 024, 030, 036, 042, 054, or 066.

(2) Variable xxx (mm stroke x 10) is 012, 018, 024, 030, 036, 042, 054, 066, 078, 090, or 102.

Technical Specifications - Kinetix MPAS Integrated Linear Stages

Kinetix MPAS Linear Stage Life Specifications

Attribute	Value
Linear bearings	10,000 km (6213.7 mi) or one year minimum life with a maximum load of 22.7 kg (50 lb) centered on lubrication intervals every 5000 km (3106.8 mi) or three months.
Ballscrew	300,000 krevs or one year minimum life with a maximum load of 11.3 kg (25 lb), 1 g maximum acceleration in a clean dry, noncontaminating environment with lubrication every 150,000 krevs or three months.
Strip seal	10,000,000 cycles or 10,000 km min life in clean, dry, noncontaminating environment.
Cable track module	10,000,000 cycles minimum life.
Mechanical stop bumper	56.49 N·m (500 lb·in) potential energy.

Kinetix MPAS Linear Stage Accuracy Specifications

Linear Stage Cat. No.	Drive Mechanism and Feedback Type	Bi-directional Repeatability (1)	Accuracy (1)	Straightness	Flatness
MPAS-A/B6xxx1-V05SxA MPAS-A/B6xxx2-V20SxA MPAS-A/B8xxx1-V05SxA MPAS-A/B8xxx2-V20SxA MPAS-A/B9xxx1-V05SxA MPAS-A/B9xxx2-V20SxA	Ballscrew with absolute multi-turn rotary encoder	±60 µm (±0.002 in.)	60 µm + 167 µm/m (0.002 in. + 0.002 in./ft)	10 µm + 50 µm/m	10 µm + 50 µm/m
MPAS-A6xxxB-ALMx2C MPAS-A8xxxE-ALMx2C MPAS-B8xxxF-ALMx2C MPAS-A9xxxK-ALMx2C MPAS-B9xxxL-ALMx2C	Linear Motor with incremental linear encoder	±15 µm (±0.0005 in.)	100 µm + 20 µm/m (0.004 in. + 0.0002 in./ft)		

(1) Measured at 20 °C (68 °F).

Load Force Ratings Specifications

The static moment and force ratings shown in the performance specifications tables are the maximum permissible values possible before permanent damage to the linear stage can occur. To determine the estimated L10 bearing and ballscrew life of Kinetix MPAS linear stages, use Motion Analyzer software, version 4.4 or later.

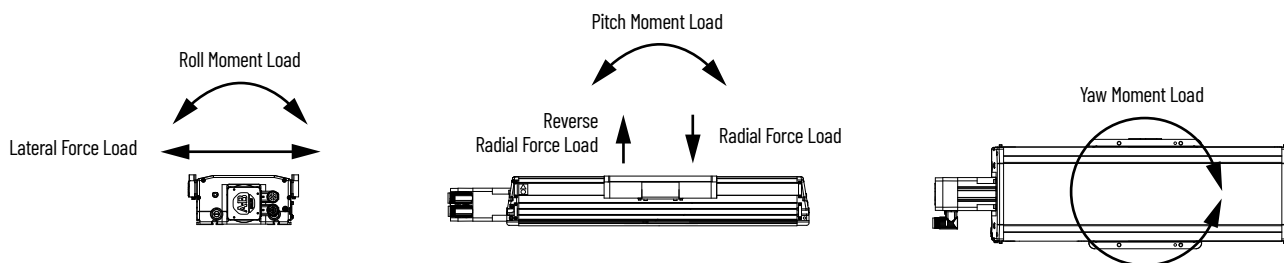

Performance Specifications with 200V-class Drives

Kinetix MPAS Linear Stage Performance Specifications (150 mm frame size)

Linear Stage Cat. No.	Screw Lead mm (in.)	Stroke Length mm (in.)	Velocity, max mm/s (in/s)	Cont. Stall Force N (lb)	Peak Stall Force N (lb)	Static Load, max ⁽¹⁾			Static Moment Load, max ⁽¹⁾		
						Radial N (lb)	Reverse Radial N (lb)	Lateral N (lb)	Pitch N•m (lb•ft)	Yaw N•m (lb•ft)	Roll N•m (lb•ft)
MPAS-A6xxx1-V05SxA	5.0 (0.2)	120...660	200 (7.9)	521 (117)	1212 (272)	5506 (1238)	2367 (532)	2753 (619)	195 (144)	227 (167)	92 (68)
MPAS-A6xxx2-V20SxA	20.0 (0.8)	(4.7...26.0)	1124 (44.3)	462 (104)	968 (218)						
MPAS-A6012B-ALMO2C	-	120 (4.7)	1568 (61.7)	105 (24)	359 (81)	5506 (1238)	2367 (532)	2753 (619)	195 (144)	227 (167)	92 (68)
MPAS-A6018B-ALMO2C		180 (7.1)	1920 (75.6)								
MPAS-A6024B-ALMO2C		240 (9.5)	2217 (87.3)								
MPAS-A6030B-ALMO2C		300 (11.8)	2478 (97.6)								
MPAS-A6036B-ALMO2C		360 (14.2)	2715 (106.9)								
MPAS-A6042B-ALMO2C		420 (16.5)	2933 (115.5)								
MPAS-A6054B-ALMO2C		540 (21.3)	3325 (130.9)								
MPAS-A6066B-ALMO2C		660 (26.0)	3676 (144.7)								
MPAS-A6078B-ALMO2C		780 (30.7)	3996 (157.3)								
MPAS-A6090B-ALMO2C		900 (35.4)	4293 (169.0)								
MPAS-A6102B-ALMO2C		1020 (40.2)	4570 (179.9)								
MPAS-A6114B-ALMO2C	1140 (44.9)	4831 (190.2)									
MPAS-A6012B-ALMC2C	120 (4.7)	1485 (58.5)	83 (19)	312 (70)							
MPAS-A6018B-ALMC2C	180 (7.1)	1819 (71.6)									
MPAS-A6024B-ALMC2C	240 (9.5)	2100 (82.7)									
MPAS-A6030B-ALMC2C	300 (11.8)	2348 (92.4)									
MPAS-A6036B-ALMC2C	360 (14.2)	2572 (101.3)									
MPAS-A6042B-ALMC2C	420 (16.5)	2778 (109.4)									
MPAS-A6054B-ALMC2C	540 (21.3)	3150 (124.0)									
MPAS-A6066B-ALMC2C	660 (26.0)	3483 (137.1)									
MPAS-A6078B-ALMC2C	780 (30.7)	3786 (149.1)									
MPAS-A6090B-ALMC2C	900 (35.4)	4067 (160.1)									
MPAS-A6102B-ALMC2C	1020 (40.2)	4330 (170.5)									
MPAS-A6114B-ALMC2C	1140 (44.9)	4577 (180.2)									

(1) Values apply to bearing ratings only. Contact your Rockwell Automation sales representative for structural considerations.

Kinetix MPAS Linear Stage Performance Specifications (200 mm frame size)

Linear Stage Cat. No.	Screw Lead mm (in.)	Stroke Length mm (in.)	Velocity, max mm/s (in/s)	Cont. Stall Force N (lb)	Peak Stall Force N (lb)	Static Load, max ⁽¹⁾			Static Moment Load, max ⁽¹⁾											
						Radial N (lb)	Reverse Radial N (lb)	Lateral N (lb)	Pitch N•m (lb•ft)	Yaw N•m (lb•ft)	Roll N•m (lb•ft)									
MPAS-A8xxx1-V05SxA	5.0 (0.2)	120...780 (4.7...30.7)	200 (7.9)	521 (117)	1212 (273)	9365 (2105)	4027 (905)	4683 (1053)	336 (248)	391 (288)	258 (190)									
		900 (35.4)	176 (6.9)																	
		1020 (40.1)	143 (5.6)																	
MPAS-A8xxx2-V20SxA	20.0 (0.8)	120...660 (4.7...26.0)	1124 (44.3)	462 (104)	968 (218)	9365 (2105)	4027 (905)	4683 (1053)	336 (248)	391 (288)	258 (190)									
		780 (30.7)	889 (35.0)																	
		900 (35.4)	715 (28.1)																	
		1020 (40.1)	582 (22.9)																	
MPAS-A8014E-ALM02C	20.0 (0.8)	140 (5.5)	1802 (70.9)	189 (43)	456 (103)	9365 (2105)	4027 (905)	4683 (1053)	336 (248)	391 (288)	258 (190)									
MPAS-A8020E-ALM02C		200 (7.9)	2154 (84.8)																	
MPAS-A8026E-ALM02C		260 (10.2)	2456 (96.7)																	
MPAS-A8032E-ALM02C		320 (12.6)	2725 (107.3)																	
MPAS-A8038E-ALM02C		380 (15.0)	2969 (116.9)																	
MPAS-A8044E-ALM02C		440 (17.3)	3195 (125.8)																	
MPAS-A8056E-ALM02C		560 (22.0)	3605 (141.9)																	
MPAS-A8068E-ALM02C		680 (26.8)	3972 (156.4)																	
MPAS-A8080E-ALM02C		800 (31.5)	4308 (169.6)																	
MPAS-A8092E-ALM02C		920 (36.2)	4620 (181.9)																	
MPAS-A8104E-ALM02C		1040 (40.9)	4912 (193.4)																	
MPAS-A8128E-ALM02C		1280 (50.4)	5000 (196.8)																	
MPAS-A8152E-ALM02C		1520 (59.8)	5000 (196.8)																	
MPAS-A8176E-ALM02C		1760 (69.3)																		
MPAS-A8194E-ALM02C		1940 (76.4)																		
MPAS-A8014E-ALMS2C		20.0 (0.8)	140 (5.5)									1710 (67.3)	159 (36)	399 (90)	9100 (2046)	4100 (922)	4700 (1057)	402 (297)	492 (363)	245 (181)
MPAS-A8020E-ALMS2C			200 (7.9)									2044 (80.5)								
MPAS-A8026E-ALMS2C	260 (10.2)		2330 (91.7)																	
MPAS-A8032E-ALMS2C	320 (12.6)		2585 (101.8)																	
MPAS-A8038E-ALMS2C	380 (15.0)		2817 (110.9)																	
MPAS-A8044E-ALMS2C	440 (17.3)		3032 (119.4)																	
MPAS-A8056E-ALMS2C	560 (22.0)		3420 (134.6)																	
MPAS-A8068E-ALMS2C	680 (26.8)		3769 (148.4)																	
MPAS-A8080E-ALMS2C	800 (31.5)		4088 (160.9)																	
MPAS-A8092E-ALMS2C	920 (36.2)		4384 (172.6)																	
MPAS-A8104E-ALMS2C	1040 (40.9)		4661 (183.5)																	
MPAS-A8128E-ALMS2C	1280 (50.4)		5000 (196.8)																	
MPAS-A8152E-ALMS2C	1520 (59.8)																			
MPAS-A8176E-ALMS2C	1760 (69.3)																			
MPAS-A8194E-ALMS2C	1940 (76.4)																			

(1) Values apply to bearing ratings only. Contact your Rockwell Automation sales representative for structural considerations.

Kinetix MPAS Linear Stage Performance Specifications (250 mm frame size)

Linear Stage Cat. No.	Screw Lead mm (in.)	Stroke Length mm (in.)	Velocity, max mm/s (in/s)	Cont. Stall Force N (lb)	Peak Stall Force N (lb)	Static Load, max ⁽¹⁾			Static Moment Load, max ⁽¹⁾										
						Radial N (lb)	Reverse Radial N (lb)	Lateral N (lb)	Pitch N•m (lb•ft)	Yaw N•m (lb•ft)	Roll N•m (lb•ft)								
MPAS-A9xxx1-V05SxA	5.0 (0.2)	120...780 (4.7...30.7)	200 (7.9)	521 (117)	1212 (273)														
		900 (35.4)	176 (6.9)																
		1020 (40.1)	143 (5.6)																
MPAS-A9xxx2-V20SxA	20.0 (0.8)	120...660 (4.7...26.0)	1124 (44.3)	462 (104)	968 (218)	13,282 (2986)	5711 (1284)	6641 (1493)	477 (352)	555 (409)	468 (345)								
		780 (30.7)	889 (35.0)																
		900 (35.4)	715 (28.1)																
		1020 (40.1)	582 (22.9)																
MPAS-A9014K-ALM02C		140 (5.5)	1875 (73.8)	285 (64)	680 (153)														
MPAS-A9020K-ALM02C		200 (7.9)	2241 (88.2)																
MPAS-A9026K-ALM02C		260 (10.2)	2555 (100.6)																
MPAS-A9032K-ALM02C		320 (12.6)	2834 (111.6)																
MPAS-A9038K-ALM02C		380 (15.0)	3089 (121.6)																
MPAS-A9044K-ALM02C		440 (17.3)	3324 (130.9)																
MPAS-A9056K-ALM02C		560 (22.0)	3749 (147.6)																
MPAS-A9068K-ALM02C		680 (26.8)	4132 (162.7)																
MPAS-A9080K-ALM02C		800 (31.5)	4481 (176.4)																
MPAS-A9092K-ALM02C		920 (36.2)	4806 (189.2)																
MPAS-A9104K-ALM02C		1040 (40.9)	5000 (196.8)																
MPAS-A9128K-ALM02C		1280 (50.4)																	
MPAS-A9152K-ALM02C		1520 (59.8)																	
MPAS-A9176K-ALM02C		1760 (69.3)																	
MPAS-A9194K-ALM02C		1940 (76.4)																	
MPAS-A9014K-ALMS2C		140 (5.5)	1779 (70.0)									245 (55)	601 (135)	12,900 (2900)	5800 (1304)	6600 (1484)	582 (429)	714 (527)	444 (328)
MPAS-A9020K-ALMS2C		200 (7.9)	2127 (83.7)																
MPAS-A9026K-ALMS2C	260 (10.2)	2425 (95.5)																	
MPAS-A9032K-ALMS2C	320 (12.6)	2690 (105.9)																	
MPAS-A9038K-ALMS2C	380 (15.0)	2931 (115.4)																	
MPAS-A9044K-ALMS2C	440 (17.3)	3154 (124.2)																	
MPAS-A9056K-ALMS2C	560 (22.0)	3559 (140.1)																	
MPAS-A9068K-ALMS2C	680 (26.8)	3921 (154.4)																	
MPAS-A9080K-ALMS2C	800 (31.5)	4253 (167.4)																	
MPAS-A9092K-ALMS2C	920 (36.2)	4561 (179.6)																	
MPAS-A9104K-ALMS2C	1040 (40.9)	4850 (190.9)																	
MPAS-A9128K-ALMS2C	1280 (50.4)	5000 (196.8)																	
MPAS-A9152K-ALMS2C	1520 (59.8)																		
MPAS-A9176K-ALMS2C	1760 (69.3)																		
MPAS-A9194K-ALMS2C	1940 (76.4)																		

(1) Values apply to bearing ratings only. Contact your Rockwell Automation sales representative for structural considerations.

Performance Specifications with 400V-class Drives

Kinetix MPAS Linear Stage Performance Specifications (150 mm frame size)

Linear Stage Cat. No.	Screw Lead mm (in.)	Stroke Length mm (in.)	Velocity, max mm/s (in/s)	Cont. Stall Force N (lb)	Peak Stall Force N (lb)	Static Load, max ⁽¹⁾			Static Moment Load, max ⁽¹⁾		
						Radial N (lb)	Reverse Radial N (lb)	Lateral N (lb)	Pitch N•m (lb•ft)	Yaw N•m (lb•ft)	Roll N•m (lb•ft)
MPAS-B6xxx1-V05SxA	5.0 (0.2)	120...660 (4.7...26.0)	200 (7.9)	521 (117)	1212 (273)	5506 (1238)	2367 (532)	2753 (619)	195 (144)	227 (167)	92 (68)
MPAS-B6xxx2-V20SxA	20.0 (0.8)		1124 (44.3)	462 (104)	968 (218)						

(1) Values apply to bearing ratings only. Contact your Rockwell Automation sales representative for structural considerations.

Kinetix MPAS Linear Stage Performance Specifications (200 mm frame size)

Linear Stage Cat. No.	Screw Lead mm (in.)	Stroke Length mm (in.)	Velocity, max mm/s (in/s)	Cont. Stall Force N (lb)	Peak Stall Force N (lb)	Static Load, max ⁽¹⁾			Static Moment Load, max ⁽¹⁾		
						Radial N (lb)	Reverse Radial N (lb)	Lateral N (lb)	Pitch N•m (lb•ft)	Yaw N•m (lb•ft)	Roll N•m (lb•ft)
MPAS-B8xxx1-V05SxA	5.0 (0.2)	120...780 (4.7...30.7)	200 (7.9)	521 (117)	1212 (273)	9365 (2105)	4027 (905)	4683 (1053)	336 (248)	391 (288)	258 (180)
		900 (35.4)	176 (6.9)								
		1020 (40.1)	143 (5.6)								
MPAS-B8xxx2-V20SxA	20.0 (0.8)	120...660 (4.7...26.0)	1124 (44.3)	462 (104)	968 (218)	9100 (2046)	4100 (922)	4700 (1057)	402 (297)	492 (363)	245 (181)
		780 (30.7)	889 (35.0)								
		900 (35.4)	715 (28.1)								
		1020 (40.1)	582 (22.9)								
MPAS-B8014F-ALM02C	-	140 (5.5)	1802 (70.9)	189 (43)	456 (103)	9100 (2046)	4100 (922)	4700 (1057)	402 (297)	492 (363)	245 (181)
MPAS-B8020F-ALM02C		200 (7.9)	2154 (84.8)								
MPAS-B8026F-ALM02C		260 (10.2)	2456 (96.7)								
MPAS-B8032F-ALM02C		320 (12.6)	2725 (107.3)								
MPAS-B8038F-ALM02C		380 (15.0)	2969 (116.9)								
MPAS-B8044F-ALM02C		440 (17.3)	3195 (125.8)								
MPAS-B8056F-ALM02C		560 (22.0)	3605 (141.9)								
MPAS-B8068F-ALM02C		680 (26.8)	3972 (156.4)								
MPAS-B8080F-ALM02C		800 (31.5)	4308 (169.6)								
MPAS-B8092F-ALM02C		920 (36.2)	4620 (181.9)								
MPAS-B8104F-ALM02C		1040 (40.9)	4912 (193.4)								
MPAS-B8128F-ALM02C		1280 (50.4)	5000 (196.8)								
MPAS-B8152F-ALM02C		1520 (59.8)	5000 (196.8)								
MPAS-B8176F-ALM02C		1760 (69.3)									
MPAS-B8194F-ALM02C	1940 (76.4)										
MPAS-B8014F-ALMS2C	-	140 (5.5)	1710 (67.3)	159 (36)	399 (90)	9100 (2046)	4100 (922)	4700 (1057)	402 (297)	492 (363)	245 (181)
MPAS-B8020F-ALMS2C		200 (7.9)	2044 (80.5)								
MPAS-B8026F-ALMS2C		260 (10.2)	2330 (91.7)								
MPAS-B8032F-ALMS2C		320 (12.6)	2585 (101.8)								
MPAS-B8038F-ALMS2C		380 (15.0)	2817 (110.9)								
MPAS-B8044F-ALMS2C		440 (17.3)	3032 (119.4)								
MPAS-B8056F-ALMS2C		560 (22.0)	3420 (134.6)								
MPAS-B8068F-ALMS2C		680 (26.8)	3769 (148.4)								
MPAS-B8080F-ALMS2C		800 (31.5)	4088 (160.9)								
MPAS-B8092F-ALMS2C		920 (36.2)	4384 (172.6)								
MPAS-B8104F-ALMS2C		1040 (40.9)	4661 (183.5)								
MPAS-B8128F-ALMS2C		1280 (50.4)	5000 (196.8)								
MPAS-B8152F-ALMS2C		1520 (59.8)									
MPAS-B8176F-ALMS2C		1760 (69.3)									
MPAS-B8194F-ALMS2C	1940 (76.4)										

(1) Values apply to bearing ratings only. Contact your Rockwell Automation sales representative for structural considerations.

Kinetix MPAS Linear Stage Performance Specifications, 250 mm frame size

Linear Stage Cat. No.	Screw Lead mm (in.)	Stroke Length mm (in.)	Velocity, max mm/s (in/s)	Cont. Stall Force N (lb)	Peak Stall Force N (lb)	Static Load, max ⁽¹⁾			Static Moment Load, max ⁽¹⁾											
						Radial N (lb)	Reverse Radial N (lb)	Lateral N (lb)	Pitch N·m (lb·ft)	Yaw N·m (lb·ft)	Roll N·m (lb·ft)									
MPAS-B9xxx1-V05SxA	5.0 (0.2)	120...780 (4.7...30.7)	200 (7.9)	521 (117)	1212 (273)	13,282 (2986)	5711 (1284)	6641 (1493)	477 (352)	555 (409)	468 (345)									
		900 (35.4)	176 (6.9)																	
		1020 (40.1)	143 (5.6)																	
MPAS-B9xxx2-V20SxA	20.0 (0.8)	120...660 (4.7...26.0)	1124 (44.3)	462 (104)	968 (218)	13,282 (2986)	5711 (1284)	6641 (1493)	477 (352)	555 (409)	468 (345)									
		780 (30.7)	889 (35.0)																	
		900 (35.4)	715 (28.1)																	
		1020 (40.1)	582 (22.9)																	
MPAS-B9014L-ALM02C	-	140 (5.5)	1875 (73.8)	285 (64)	680 (153)	12,900 (2900)	5800 (1304)	6600 (1484)	582 (429)	714 (527)	444 (328)									
MPAS-B9020L-ALM02C		200 (7.9)	2241 (88.2)																	
MPAS-B9026L-ALM02C		260 (10.2)	2555 (100.6)																	
MPAS-B9032L-ALM02C		320 (12.6)	2834 (111.6)																	
MPAS-B9038L-ALM02C		380 (15.0)	3089 (121.6)																	
MPAS-B9044L-ALM02C		440 (17.3)	3324 (130.9)																	
MPAS-B9056L-ALM02C		560 (22.0)	3749 (147.6)																	
MPAS-B9068L-ALM02C		680 (26.8)	4132 (162.7)																	
MPAS-B9080L-ALM02C		800 (31.5)	4481 (176.4)																	
MPAS-B9092L-ALM02C		920 (36.2)	4806 (189.2)																	
MPAS-B9104L-ALM02C		1040 (40.9)	5000 (196.8)																	
MPAS-B9128L-ALM02C		1280 (50.4)																		
MPAS-B9152L-ALM02C		1520 (59.8)																		
MPAS-B9176L-ALM02C		1760 (69.3)																		
MPAS-B9194L-ALM02C		1940 (76.4)																		
MPAS-B9014L-ALMS2C		-	140 (5.5)									1779 (70.0)	245 (55)	601 (135)	12,900 (2900)	5800 (1304)	6600 (1484)	582 (429)	714 (527)	444 (328)
MPAS-B9020L-ALMS2C			200 (7.9)									2127 (83.7)								
MPAS-B9026L-ALMS2C	260 (10.2)		2425 (95.5)																	
MPAS-B9032L-ALMS2C	320 (12.6)		2690 (105.9)																	
MPAS-B9038L-ALMS2C	380 (15.0)		2931 (115.4)																	
MPAS-B9044L-ALMS2C	440 (17.3)		3154 (124.2)																	
MPAS-B9056L-ALMS2C	560 (22.0)		3559 (140.1)																	
MPAS-B9068L-ALMS2C	680 (26.8)		3921 (154.4)																	
MPAS-B9080L-ALMS2C	800 (31.5)		4253 (167.4)																	
MPAS-B9092L-ALMS2C	920 (36.2)		4561 (179.6)																	
MPAS-B9104L-ALMS2C	1040 (40.9)		4850 (190.9)																	
MPAS-B9128L-ALMS2C	1280 (50.4)		5000 (196.8)																	
MPAS-B9152L-ALMS2C	1520 (59.8)																			
MPAS-B9176L-ALMS2C	1760 (69.3)																			
MPAS-B9194L-ALMS2C	1940 (76.4)																			

(1) Values apply to bearing ratings only. Contact your Rockwell Automation sales representative for structural considerations.

Motor Brake Specifications

Linear Stage Cat. No.	Backlash, max (brake engaged) µm (in.)	Holding Force N (lb)	Coil Current at 24V DC A	Brake Response Time		
				Release ms	Engage (by using external arc suppression device)	
					MOV ms	Diode ms
MPAS-A/Bxxxx1-V05SxA	100 (0.004)	5187 (1166)	0.46...0.56	58	20	42
MPAS-A/Bxxxx2-V20SxA		1294 (291)				

Standard Stroke Length and Weight Specifications

Kinetix MPAS Linear Stages, Ballscrew (150 mm frame size)

Linear Stage Cat. No.	Standard Stroke Lengths mm (in.)	Weight, approx kg (lb)
MPAS-A/B6xxx2-V20S2A 20 mm/rev (0.8 in./rev) Ballscrew without brake	120 (4.7)	14.5 (32.0)
	180 (7.1)	15.4 (33.9)
	240 (9.5)	16.3 (35.8)
	300 (11.8)	17.1 (37.7)
	360 (14.2)	18.0 (39.6)
	420 (16.5)	18.9 (41.5)
	540 (21.3)	20.6 (45.4)
	660 (26.0)	22.4 (49.2)
MPAS-A/B6xxx2-V20S4A 20 mm/rev (0.8 in./rev) Ballscrew with brake	120 (4.7)	15.0 (33.0)
	180 (7.1)	15.9 (34.9)
	240 (9.5)	16.7 (36.8)
	300 (11.8)	17.6 (38.7)
	360 (14.2)	18.5 (40.6)
	420 (16.5)	19.3 (42.5)
	540 (21.3)	21.1 (46.4)
	660 (26.0)	22.8 (50.2)

Linear Stage Cat. No.	Standard Stroke Lengths mm (in.)	Weight, approx kg (lb)
MPAS-A/B6xxx1-V05S2A 5 mm/rev (0.2 in./rev) Ballscrew without brake	120 (4.7)	13.9 (30.5)
	180 (7.1)	14.7 (32.4)
	240 (9.5)	15.6 (34.3)
	300 (11.8)	16.4 (36.2)
	360 (14.2)	17.3 (38.1)
	420 (16.5)	18.2 (40.0)
	540 (21.3)	19.9 (43.7)
	660 (26.0)	21.6 (47.5)
MPAS-A/B6xxx1-V05S4A 5 mm/rev (0.2 in./rev) Ballscrew with brake	120 (4.7)	14.3 (31.5)
	180 (7.1)	15.2 (33.4)
	240 (9.5)	16.0 (35.3)
	300 (11.8)	16.9 (37.2)
	360 (14.2)	17.8 (39.1)
	420 (16.5)	18.6 (40.9)
	540 (21.3)	20.3 (44.7)
	660 (26.0)	22.1 (48.5)

Kinetix MPAS Linear Stages, Direct Drive (150 mm frame size)

Linear Stage Cat. No.	Standard Stroke Lengths mm (in.)	Weight, approx without Cover kg (lb)	Weight, approx with Cover kg (lb)
MPAS-A6xxxB-ALMx2C Direct drive without brake	120 (4.7)	18.7 (41.0)	20.3 (44.7)
	180 (7.1)	20.0 (44.0)	21.8 (48.0)
	240 (9.5)	21.4 (47.1)	23.4 (51.4)
	300 (11.8)	22.8 (50.1)	24.9 (54.8)
	360 (14.2)	24.1 (53.1)	26.5 (58.2)
	420 (16.5)	25.5 (56.1)	28.0 (61.6)
	540 (21.3)	28.3 (62.3)	31.1 (68.4)
	660 (26.0)	31.0 (68.3)	34.2 (75.2)
	780 (30.7)	33.8 (74.3)	37.2 (81.9)
	900 (35.4)	36.5 (80.4)	40.3 (88.7)
	1020 (40.2)	39.5 (86.9)	43.6 (95.9)
	1140 (44.9)	42.3 (93.0)	46.7 (102.7)

Kinetix MPAS Linear Stages, Ballscrew (200 mm frame size)

Linear Stage Cat. No.	Standard Stroke Lengths mm (in.)	Weight, approx kg (lb)
MPAS-A/B8xxx2-V20S2A 20 mm/rev (0.8 in./rev) Ballscrew without brake	120 (4.7)	16.5 (36.3)
	180 (7.1)	17.5 (38.4)
	240 (9.5)	18.4 (40.5)
	300 (11.8)	19.4 (42.7)
	360 (14.2)	20.4 (44.8)
	420 (16.5)	21.4 (47.0)
	540 (21.3)	23.3 (51.3)
	660 (26.0)	25.2 (55.5)
	780 (30.7)	27.2 (59.8)
	900 (35.4)	29.1 (64.1)
1020 (40.2)	31.1 (68.4)	
MPAS-A/B8xxx2-V20S4A 20 mm/rev (0.8 in./rev) Ballscrew with brake	120 (4.7)	16.9 (37.2)
	180 (7.1)	17.9 (39.4)
	240 (9.5)	18.9 (41.5)
	300 (11.8)	19.9 (43.7)
	360 (14.2)	20.8 (45.8)
	420 (16.5)	21.8 (48.0)
	540 (21.3)	23.8 (52.3)
	660 (26.0)	25.7 (56.5)
	780 (30.7)	27.7 (60.8)
	900 (35.4)	29.6 (65.1)
1020 (40.2)	31.6 (69.4)	

Linear Stage Cat. No.	Standard Stroke Lengths mm (in.)	Weight, approx kg (lb)
MPAS-A/B8xxx1-V05S2A 5 mm/rev (0.2 in./rev) Ballscrew without brake	120 (4.7)	15.9 (34.9)
	180 (7.1)	16.8 (37.0)
	240 (9.5)	17.8 (39.2)
	300 (11.8)	18.8 (41.3)
	360 (14.2)	19.8 (43.5)
	420 (16.5)	20.7 (45.6)
	540 (21.3)	22.7 (49.9)
	660 (26.0)	24.6 (54.2)
	780 (30.7)	26.6 (58.5)
	900 (35.4)	28.5 (62.7)
1020 (40.2)	30.5 (67.1)	
MPAS-A/B8xxx1-V05S4A 5 mm/rev (0.2 in./rev) Ballscrew with brake	120 (4.7)	16.3 (35.9)
	180 (7.1)	17.3 (38.0)
	240 (9.5)	18.3 (40.2)
	300 (11.8)	19.2 (42.3)
	360 (14.2)	20.2 (44.5)
	420 (16.5)	21.2 (46.6)
	540 (21.3)	23.1 (50.9)
	660 (26.0)	25.1 (55.2)
	780 (30.7)	27.0 (59.5)
	900 (35.4)	29.0 (63.8)
1020 (40.2)	30.9 (68.0)	

Kinetix MPAS Linear Stages, Direct Drive (200 mm frame size)

Linear Stage Cat. No.	Standard Stroke Lengths mm (in.)	Weight, approx without Cover kg (lb)	Weight, approx with Cover kg (lb)
MPAS-A8xxxE-ALMx2C MPAS-B8xxxF-ALMx2C Direct drive without brake	140 (5.5)	21.0 (46.1)	22.6 (49.8)
	200 (7.9)	21.9 (48.2)	23.7 (52.2)
	260 (10.2)	22.8 (50.2)	24.9 (54.7)
	320 (12.6)	24.1 (53.0)	26.3 (57.8)
	380 (15.0)	24.7 (54.3)	27.1 (59.5)
	440 (17.3)	26.0 (57.1)	28.5 (62.7)
	560 (22.0)	27.9 (61.3)	30.8 (67.7)
	680 (26.8)	29.7 (65.4)	33.0 (72.5)
	800 (31.5)	31.9 (70.2)	35.5 (78.1)
	920 (36.2)	34.1 (75.1)	38.1 (83.7)
	1040 (40.9)	36.2 (79.6)	40.5 (89.1)
	1280 (50.4)	39.9 (87.8)	44.9 (98.8)
	1520 (59.8)	44.4 (97.6)	50.1 (110.1)
	1760 (69.3)	48.1 (105.8)	54.5 (119.9)
	1940 (76.4)	51.2 (112.7)	58.1 (127.9)
680 (26.8)	29.7 (65.4)	33.0 (72.5)	

Kinetix MPAS Linear Stages, Ballscrew (250 mm frame size)

Linear Stage Cat. No.	Standard Stroke Lengths mm (in.)	Weight, approx kg (lb)
MPAS-A/B9xxx2-V20S2A 20 mm/rev (0.8 in./rev) Ballscrew without brake	120 (4.7)	19.8 (43.6)
	180 (7.1)	21.1 (46.4)
	240 (9.5)	22.4 (49.2)
	300 (11.8)	23.6 (52.0)
	360 (14.2)	24.9 (54.8)
	420 (16.5)	26.2 (57.6)
	540 (21.3)	28.7 (63.2)
	660 (26.0)	31.3 (68.8)
	780 (30.7)	33.8 (74.3)
	900 (35.4)	36.3 (79.9)
1020 (40.2)	38.9 (85.5)	
MPAS-A/B9xxx2-V20S4A 20 mm/rev (0.8 in./rev) Ballscrew with brake	120 (4.7)	20.3 (44.6)
	180 (7.1)	21.5 (47.4)
	240 (9.5)	22.8 (50.2)
	300 (11.8)	24.1 (53.0)
	360 (14.2)	25.4 (55.8)
	420 (16.5)	26.6 (58.6)
	540 (21.3)	29.2 (64.2)
	660 (26.0)	31.7 (69.7)
	780 (30.7)	34.2 (75.3)
	900 (35.4)	36.8 (80.9)
1020 (40.2)	39.3 (86.5)	

Linear Stage Cat. No.	Standard Stroke Lengths mm (in.)	Weight, approx kg (lb)
MPAS-A/B9xxx1-V05S2A 5 mm/rev (0.2 in./rev) Ballscrew without brake	120 (4.7)	19.2 (42.3)
	180 (7.1)	20.5 (45.0)
	240 (9.5)	21.8 (47.9)
	300 (11.8)	23.0 (50.6)
	360 (14.2)	24.3 (53.4)
	420 (16.5)	25.6 (56.2)
	540 (21.3)	28.1 (61.8)
	660 (26.0)	30.6 (67.4)
	780 (30.7)	33.2 (73.0)
	900 (35.4)	35.7 (78.6)
1020 (40.2)	38.2 (84.1)	
MPAS-A/B9xxx1-V05S4A 5 mm/rev (0.2 in./rev) Ballscrew with brake	120 (4.7)	19.7 (43.3)
	180 (7.1)	20.9 (46.0)
	240 (9.5)	22.2 (48.8)
	300 (11.8)	23.5 (51.6)
	360 (14.2)	24.7 (54.4)
	420 (16.5)	26.0 (57.2)
	540 (21.3)	28.5 (62.8)
	660 (26.0)	31.1 (68.4)
	780 (30.7)	33.6 (74.0)
	900 (35.4)	36.2 (79.6)
1020 (40.2)	38.7 (85.1)	

Kinetix MPAS Linear Stages, Direct Drive (250 mm frame size)

Linear Stage Cat. No.	Standard Stroke Lengths mm (in.)	Weight, approx without Cover kg (lb)	Weight, approx with Cover kg (lb)
MPAS-A9xxxK-ALMx2C MPAS-B9xxxL-ALMx2C Direct drive without brake	140 (5.5)	26.8 (59.0)	29.0 (63.7)
	200 (7.9)	28.6 (62.8)	30.9 (68.0)
	260 (10.2)	29.8 (65.6)	32.5 (71.4)
	320 (12.6)	31.1 (68.5)	34.0 (74.7)
	380 (15.0)	32.4 (71.3)	35.5 (78.0)
	440 (17.3)	33.7 (74.2)	37.0 (81.4)
	560 (22.0)	36.8 (80.9)	40.5 (89.1)
	680 (26.8)	40.0 (87.9)	43.5 (95.8)
	800 (31.5)	42.4 (93.2)	47.0 (103.4)
	920 (36.2)	45.0 (98.9)	50.1 (110.1)
	1040 (40.9)	47.8 (105.1)	53.3 (117.3)
	1280 (50.4)	53.4 (117.4)	59.8 (131.6)
	1520 (59.8)	59.0 (129.8)	66.4 (146.0)
	1760 (69.3)	64.6 (142.1)	72.9 (160.3)
	1940 (76.4)	68.5 (150.6)	77.4 (170.3)
	680 (26.8)	40.0 (87.9)	43.5 (95.8)

Dimensions - Kinetix MPAS Integrated Linear Stages

MPAS-A/B6xxx1/2-VxxSxA (ballscrew) Linear Stage

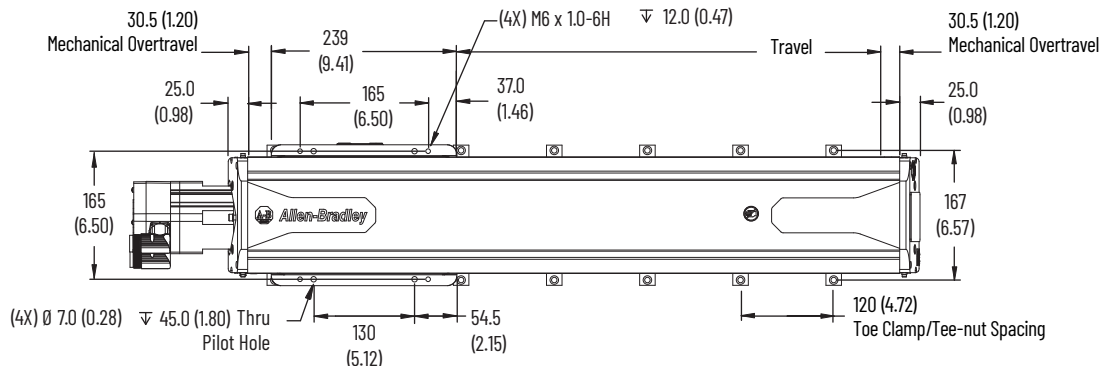

Dimensions are in mm (in.)

(4X) M10 x 1.5-6H Thru (2 per end cap)
Access point for lubricating linear bearings.
Provision to use lifting hooks (not provided).

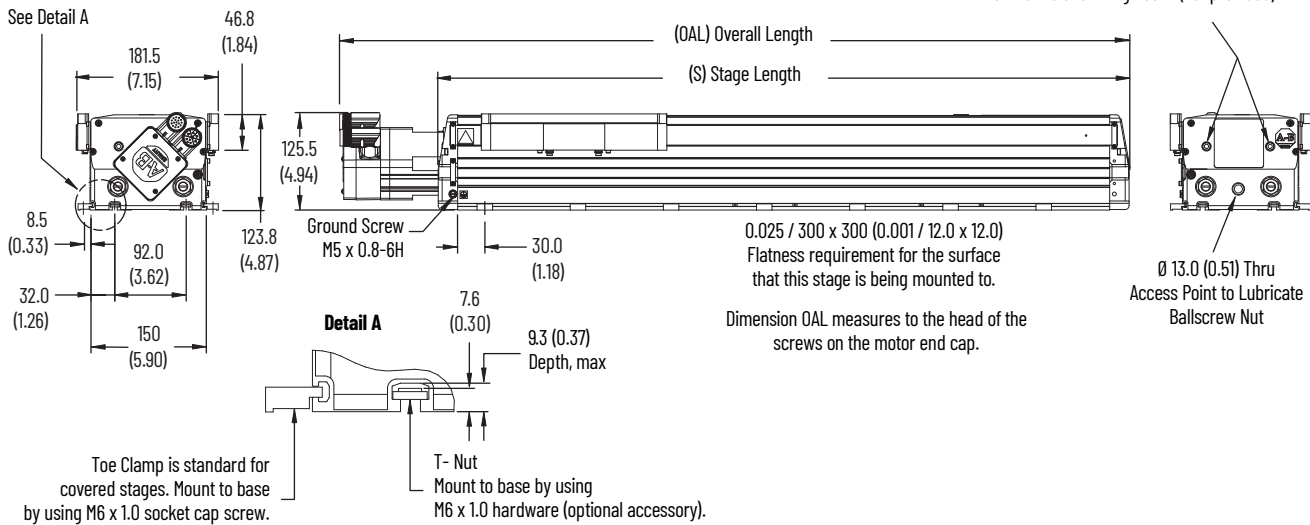

Linear Stage Cat. No.	S mm (in.)	OAL (5 mm/rev) (1) mm (in.)	OAL (20 mm/rev) (2) mm (in.)
MPAS-A/B6012x-VxxSxA	470 (18.5)	569 (22.4)	594 (23.4)
MPAS-A/B6018x-VxxSxA	530 (20.9)	629 (24.7)	654 (25.8)
MPAS-A/B6024x-VxxSxA	590 (23.2)	689 (27.1)	714 (28.1)
MPAS-A/B6030x-VxxSxA	650 (25.6)	749 (29.5)	774 (30.5)

Linear Stage Cat. No.	S mm (in.)	OAL (5 mm/rev) (1) mm (in.)	OAL (20 mm/rev) (2) mm (in.)
MPAS-A/B6036x-VxxSxA	710 (28.0)	809 (31.8)	834 (32.8)
MPAS-A/B6042x-VxxSxA	770 (30.3)	869 (34.2)	894 (35.2)
MPAS-A/B6054x-VxxSxA	890 (35.0)	989 (38.9)	1014 (39.9)
MPAS-A/B6066x-VxxSxA	1010 (39.8)	1109 (43.6)	1134 (44.6)

(1) If ordering an MPAS-A/B6xxx-V05S4A actuator with brake, add 39.0 mm (1.53 in.) to dimension OAL.
 (2) If ordering an MPAS-A/B6xxx-V20S4A actuator with brake, add 39.0 mm (1.53 in.) to dimension OAL.

Actuators are designed to metric dimensions. Inch dimensions are approximate conversions from millimeters. Dimensions without tolerances are for reference.

MPAS-A/B8xxx1/2-VxxSxA (ballscrew) Linear Stage

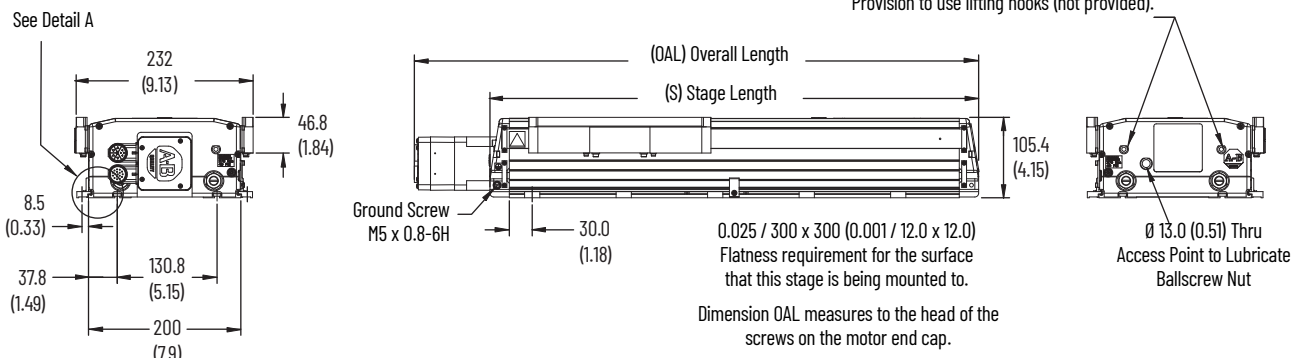
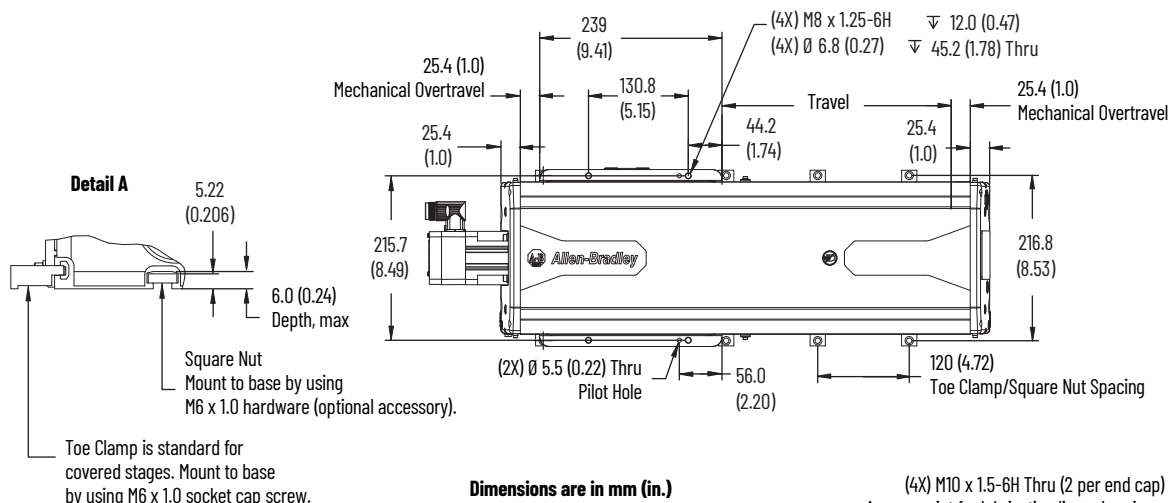

Linear Stage Cat. No.	S mm (in.)	OAL (5 mm/rev) (1) mm (in.)	OAL (20 mm/rev) (2) mm (in.)
MPAS-A/B8012x-VxxSxA	461 (18.1)	557 (21.9)	582 (22.9)
MPAS-A/B8018x-VxxSxA	521 (20.5)	617 (24.3)	642 (25.3)
MPAS-A/B8024x-VxxSxA	581 (22.9)	677 (26.6)	702 (27.6)
MPAS-A/B8030x-VxxSxA	641 (25.2)	737 (29.0)	762 (30.0)
MPAS-A/B8036x-VxxSxA	701 (27.6)	797 (31.4)	822 (32.4)
MPAS-A/B8042x-VxxSxA	761 (29.9)	857 (33.7)	882 (34.7)

Linear Stage Cat. No.	S mm (in.)	OAL (5 mm/rev) (1) mm (in.)	OAL (20 mm/rev) (2) mm (in.)
MPAS-A/B8054x-VxxSxA	881 (34.7)	977 (38.5)	1002 (39.5)
MPAS-A/B8066x-VxxSxA	1001 (39.4)	1097 (43.2)	1122 (44.2)
MPAS-A/B8078x-VxxSxA	1121 (44.1)	1217 (47.9)	1242 (48.9)
MPAS-A/B8090x-VxxSxA	1241 (48.8)	1337 (52.6)	1362 (53.6)
MPAS-A/B8102x-VxxSxA	1361 (53.6)	1457 (57.4)	1482 (58.4)

(1) If ordering an MPAS-A/B8xxx-V05S4A actuator with brake, add 39.0 mm (1.53 in.) to dimension OAL.
 (2) If ordering an MPAS-A/B8xxx-V20S4A actuator with brake, add 39.0 mm (1.53 in.) to dimension OAL.

Actuators are designed to metric dimensions. Inch dimensions are approximate conversions from millimeters. Dimensions without tolerances are for reference.

MPAS-A/B9xxx1/2-VxxSxA (ballscrew) Linear Stage

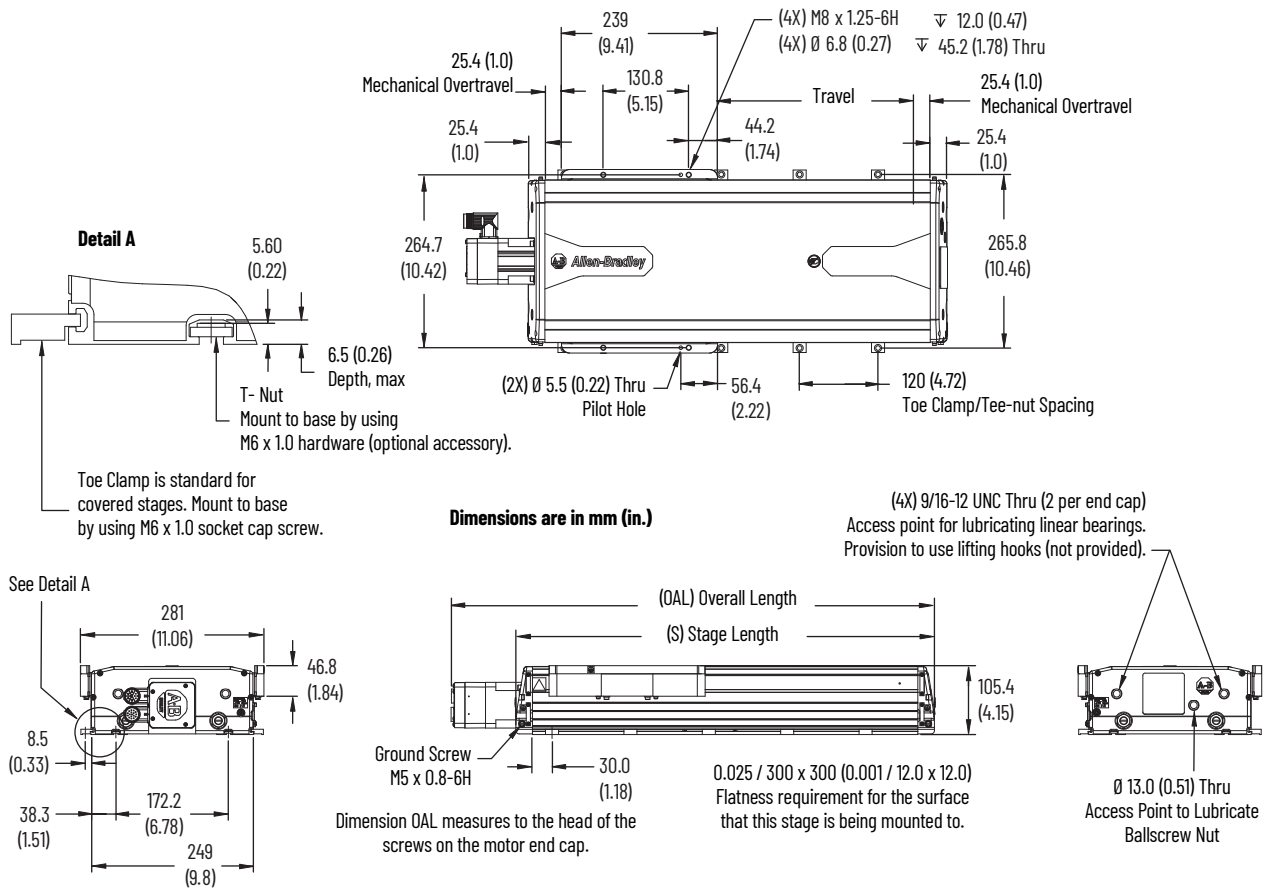

Linear Stage Cat. No.	S mm (in.)	OAL (5 mm/rev) ⁽¹⁾ mm (in.)	OAL (20 mm/rev) ⁽²⁾ mm (in.)
MPAS-A/B9012x-VxxSxA	461 (18.1)	557 (21.9)	582 (22.9)
MPAS-A/B9018x-VxxSxA	521 (20.5)	617 (24.3)	642 (25.3)
MPAS-A/B9024x-VxxSxA	581 (22.9)	677 (26.6)	702 (27.6)
MPAS-A/B9030x-VxxSxA	641 (25.2)	737 (29.0)	762 (30.0)
MPAS-A/B9036x-VxxSxA	701 (27.6)	797 (31.4)	822 (32.4)
MPAS-A/B9042x-VxxSxA	761 (29.9)	857 (33.7)	882 (34.7)

Linear Stage Cat. No.	S mm (in.)	OAL (5 mm/rev) ⁽¹⁾ mm (in.)	OAL (20 mm/rev) ⁽²⁾ mm (in.)
MPAS-A/B9054x-VxxSxA	881 (34.7)	977 (38.5)	1002 (39.5)
MPAS-A/B9066x-VxxSxA	1001 (39.4)	1097 (43.2)	1122 (44.2)
MPAS-A/B9078x-VxxSxA	1121 (44.1)	1217 (47.9)	1242 (48.9)
MPAS-A/B9090x-VxxSxA	1241 (48.8)	1337 (52.6)	1362 (53.6)
MPAS-A/B9102x-VxxSxA	1361 (53.6)	1457 (57.4)	1482 (58.4)

(1) If ordering an MPAS-A/B9xxx-V05S4A actuator with brake, add 39.0 mm (1.53 in.) to dimension OAL.
 (2) If ordering an MPAS-A/B9xxx-V20S4A actuator with brake, add 39.0 mm (1.53 in.) to dimension OAL.

Actuators are designed to metric dimensions. Inch dimensions are approximate conversions from millimeters. Dimensions without tolerances are for reference.

MPAS-A6xxxB-ALMx2C (direct drive) Linear Stage

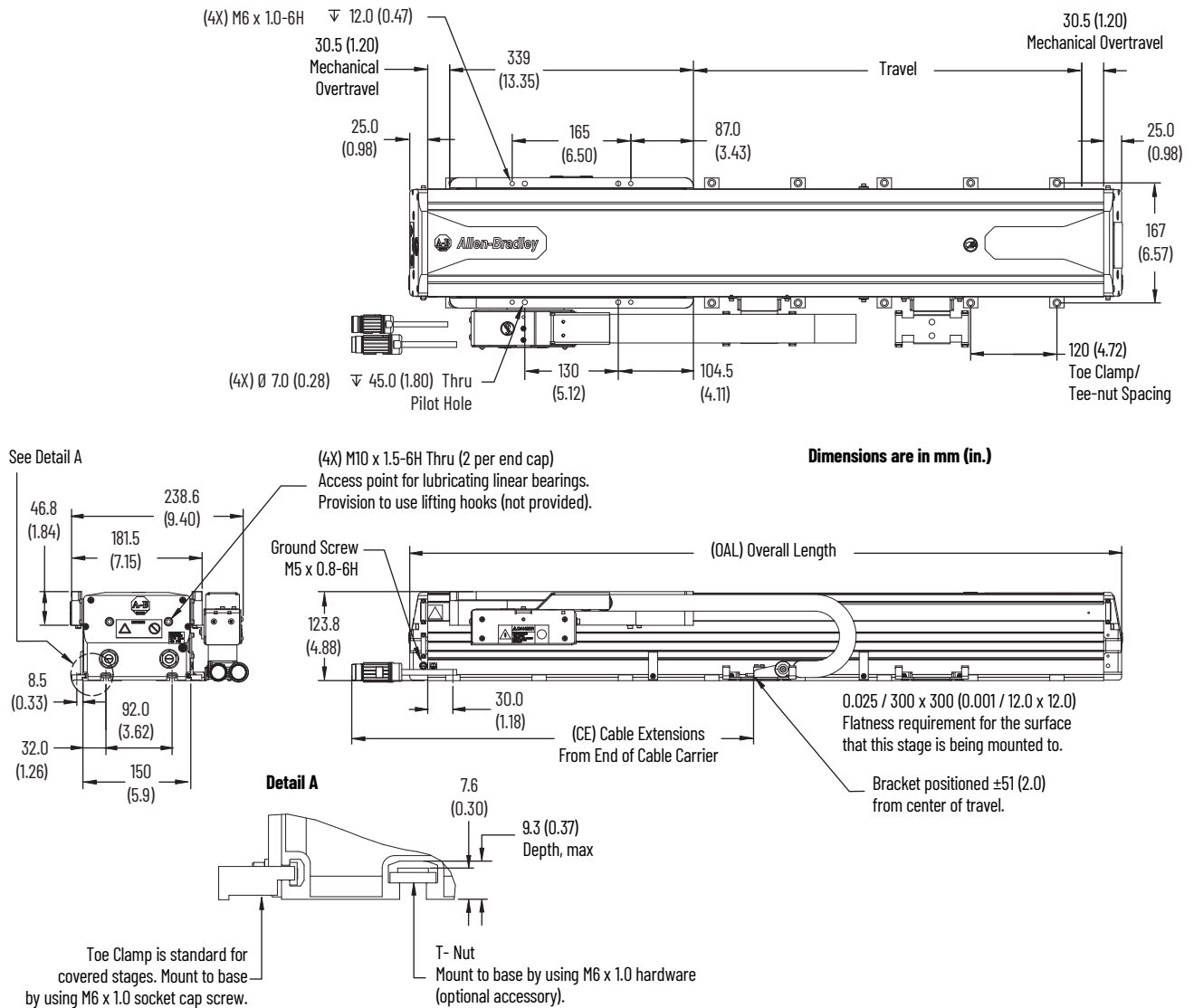

Linear Stage Cat. No.	OAL mm (in.)	CE mm (in.)
MPAS-A6012B-ALMx2C	570 (22.4)	1218 (48.0)
MPAS-A6018B-ALMx2C	630 (24.8)	1193 (47.0)
MPAS-A6024B-ALMx2C	690 (27.2)	1168 (46.0)
MPAS-A6030B-ALMx2C	750 (29.5)	1118 (44.0)
MPAS-A6036B-ALMx2C	810 (31.9)	1093 (43.0)
MPAS-A6042B-ALMx2C	870 (34.3)	1068 (42.0)

Linear Stage Cat. No.	OAL mm (in.)	CE mm (in.)
MPAS-A6054B-ALMx2C	990 (39.0)	1018 (40.0)
MPAS-A6066B-ALMx2C	1110 (43.7)	943 (37.0)
MPAS-A6078B-ALMx2C	1230 (48.4)	893 (35.0)
MPAS-A6090B-ALMx2C	1350 (53.1)	818 (32.0)
MPAS-A6102B-ALMx2C	1470 (57.9)	1768 (70.0)
MPAS-A6114B-ALMx2C	1590 (62.6)	1718 (68.0)

Actuators are designed to metric dimensions. Inch dimensions are approximate conversions from millimeters. Dimensions without tolerances are for reference.

MPAS-A/B8xxx-ALMx2C (direct drive) Linear Stage

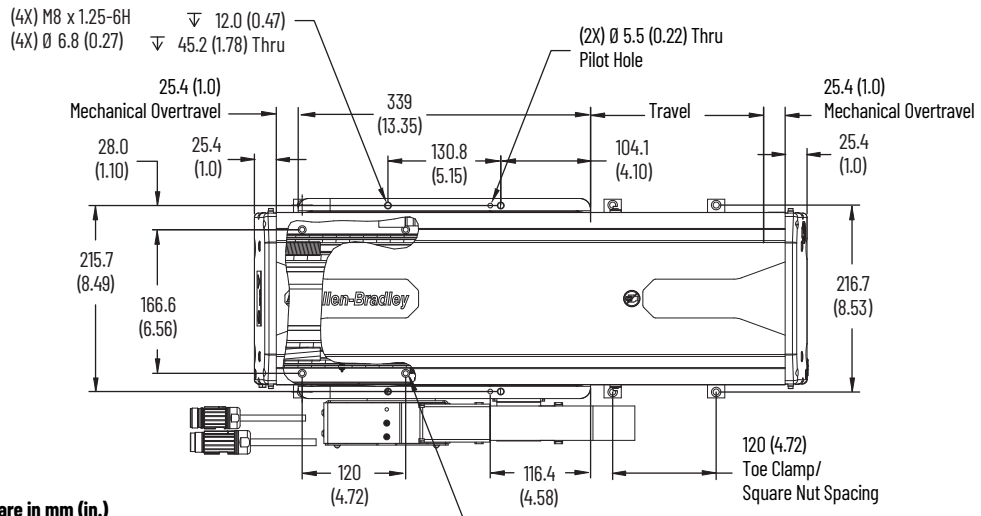

Dimensions are in mm (in.)

See Detail A

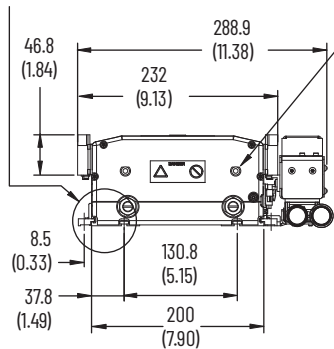

Detail A

(4X) M10 x 1.5-6H Thru (2 per end cap)
Access point for lubricating linear bearings.
Provision to use lifting hooks (not provided).

Ground Screw
M5 x 0.8-6H

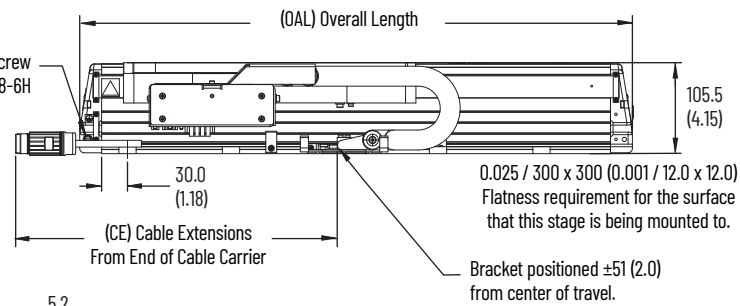

Toe Clamp is standard for covered stages. Mount to base by using M6 x 1.0 socket cap screw.

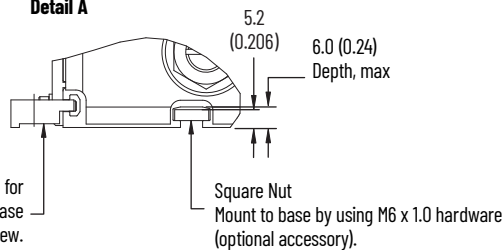

Linear Stage Cat. No.	OAL mm (in.)	CE mm (in.)	Linear Stage Cat. No.	OAL mm (in.)	CE mm (in.)	Linear Stage Cat. No.	OAL mm (in.)	CE mm (in.)
MPAS-A/B8014x-ALMx2C	581 (22.9)	1243 (49.0)	MPAS-A/B8044x-ALMx2C	881 (34.7)	1093 (43.0)	MPAS-A/B8104x-ALMx2C	1481 (58.3)	1793 (71.0)
MPAS-A/B8020x-ALMx2C	641 (25.2)	1218 (48.0)	MPAS-A/B8056x-ALMx2C	1001 (39.4)	1018 (40.0)	MPAS-A/B8128x-ALMx2C	1721 (67.8)	1668 (66.0)
MPAS-A/B8026x-ALMx2C	701 (27.6)	1168 (46.0)	MPAS-A/B8068x-ALMx2C	1121 (44.1)	968 (38.0)	MPAS-A/B8152x-ALMx2C	1961 (77.2)	1543 (61.0)
MPAS-A/B8032x-ALMx2C	761 (30.0)	1143 (45.0)	MPAS-A/B8080x-ALMx2C	1241 (48.9)	918 (36.0)	MPAS-A/B8176x-ALMx2C	2201 (86.7)	1418 (56.0)
MPAS-A/B8038x-ALMx2C	821 (32.3)	1118 (44.0)	MPAS-A/B8092x-ALMx2C	1361 (53.6)	843 (33.0)	MPAS-A/B8194x-ALMx2C	2381 (93.7)	1343 (53.0)

Actuators are designed to metric dimensions. Inch dimensions are approximate conversions from millimeters. Dimensions without tolerances are for reference.

MPAS-A/B9xxx-ALMx2C (direct drive) Linear Stage

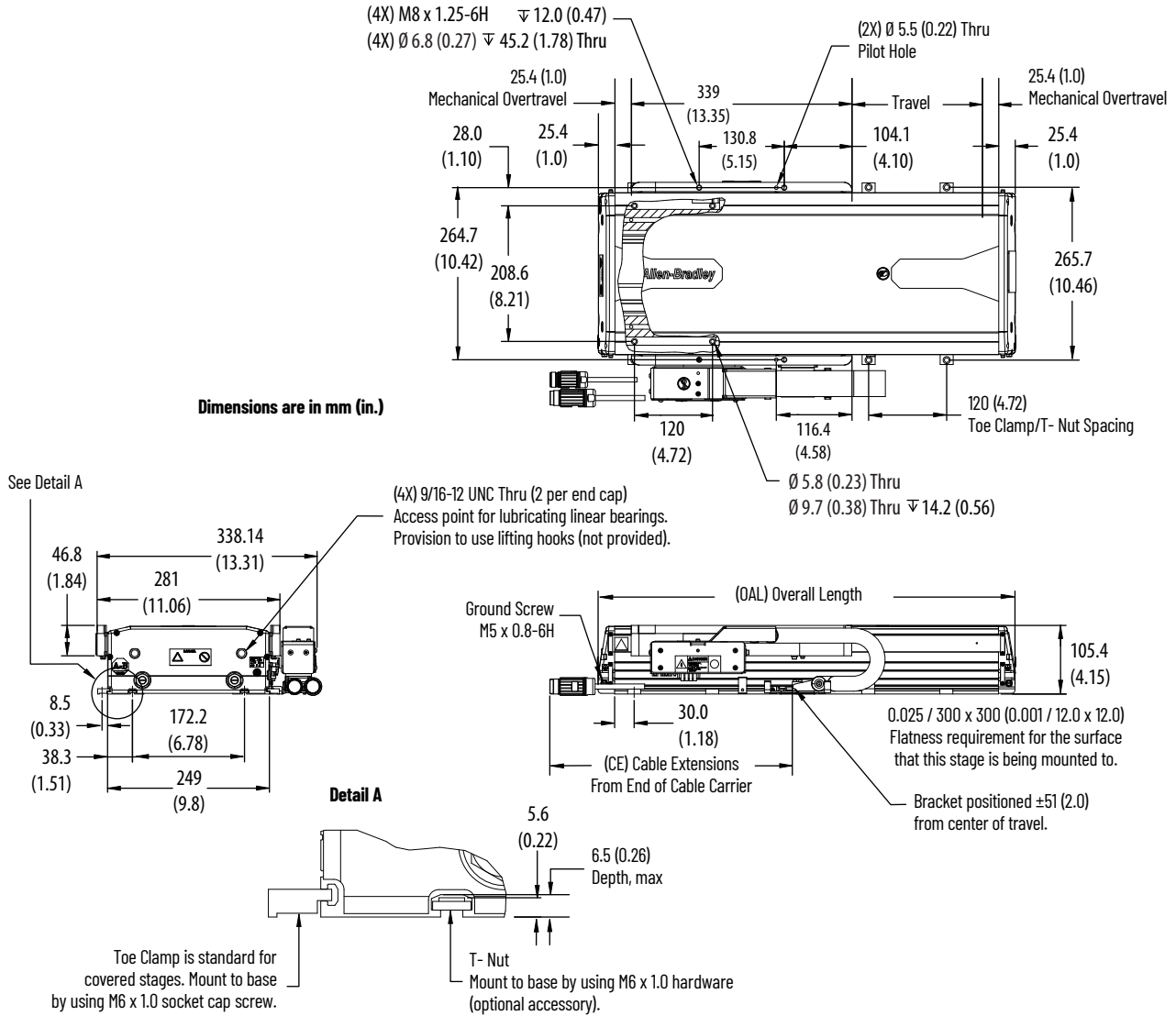

Linear Stage Cat. No.	OAL mm (in.)	CE mm (in.)
MPAS-A/B9014x-ALMx2C	581 (22.9)	1240 (49.0)
MPAS-A/B9020x-ALMx2C	641 (25.2)	1220 (48.0)
MPAS-A/B9026x-ALMx2C	701 (27.6)	1170 (46.0)
MPAS-A/B9032x-ALMx2C	761 (30.0)	1140 (45.0)
MPAS-A/B9038x-ALMx2C	821 (32.3)	1120 (44.0)

Linear Stage Cat. No.	OAL mm (in.)	CE mm (in.)
MPAS-A/B9044x-ALMx2C	881 (34.7)	1090 (43.0)
MPAS-A/B9056x-ALMx2C	1001 (39.4)	1020 (40.0)
MPAS-A/B9068x-ALMx2C	1121 (44.1)	960 (38.0)
MPAS-A/B9080x-ALMx2C	1241 (48.9)	910 (36.0)
MPAS-A/B9092x-ALMx2C	1361 (53.6)	840 (33.0)

Linear Stage Cat. No.	OAL mm (in.)	CE mm (in.)
MPAS-A/B9104x-ALMx2C	1481 (58.3)	1800 (71.0)
MPAS-A/B9128x-ALMx2C	1721 (67.8)	1670 (66.0)
MPAS-A/B9152x-ALMx2C	1961 (77.2)	1550 (61.0)
MPAS-A/B9176x-ALMx2C	2201 (86.7)	1420 (56.0)
MPAS-A/B9194x-ALMx2C	2381 (93.7)	1350 (53.0)

Actuators are designed to metric dimensions. Inch dimensions are approximate conversions from millimeters. Dimensions without tolerances are for reference.

Kinetix MPMA Integrated Multi-axis Linear Stages



Cartesian X/Y Configuration

Kinetix MPMA multi-axis linear stages extend the Allen-Bradley actuator portfolio into pre-defined and pre-assembled multi-axis configurations to suit a variety of manufacturing needs. These configurations come pre-assembled with known orthogonality and cable management, and are selectable in Motion Analyzer sizing software, version 4.7 or later.



Center Stacked X/Y Configuration

The cartesian X/Y configuration is typically used when you need to perform an operation on a workpiece from above such as picking and placing, dispensing, or scanning. This configuration is available with both direct-drive linear motors and ballscrew-actuated stages.



Center Stacked X/Z Configuration

The center stacked X/Y is a configuration that is often used to position your workpiece under a stationary object such as a camera or dispenser head. This configuration is available with both direct-drive linear motors and ballscrew-actuated stages.

The center stacked X/Z configuration is often used in applications where you need to pick an object from one line and place it on a perpendicular line. This configuration is available with both direct-drive linear motors and ballscrew actuated X-axis stages, and ballscrew actuated Z-axis stages.

Kinetix MPMA Multi-axis Linear Stage Features

- Your choice of direct-drive linear motor or ballscrew actuation. Direct-drive linear motor actuation provides greater repeatability, increased reliability, and higher dynamics. Ballscrew actuation provides greater linear thrust capabilities.
- Ease of selection in Motion Analyzer software, version 4.7 or later, that reduces the time and cost associated with selecting a multi-axis linear stage solution.
- Ease of machine design with the availability of CAD and Solid Models that reduce the time needed to generate machine drawings.
- Ease of configuration with the Studio 5000 Logix Designer application that reduces set-up time.
- Factory-supplied cable management that is field replaceable for ease of maintenance.
- Orthogonality of 30 arc seconds.

Catalog Numbers - Kinetix MPMA Multi-axis Linear Stages

Catalog numbers consist of various characters, each of which identifies a specific option for that component. Use the catalog numbering table chart below to understand the configuration of your actuator. For questions regarding product availability, contact your Allen-Bradley distributor.

MP MA - xxxxxxxx-xxx

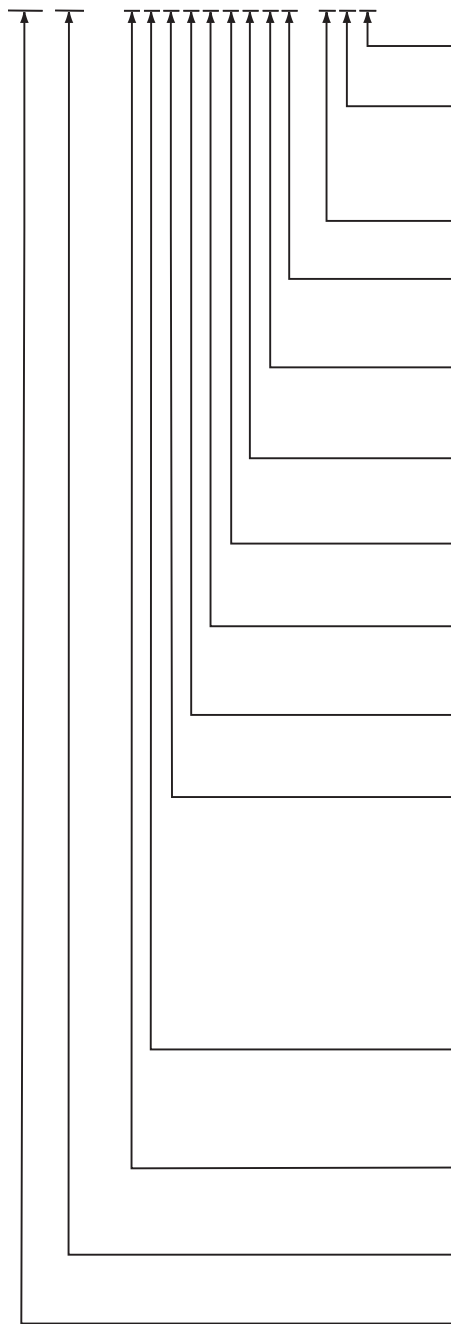

Cable

C = Cable track module with IP67 SpeedTec DIN connectors (applies to all Kinetix MPMA linear stages)

Limits and Brake Options

X-axisY-axisZ-axis

1 = No brake, no limits 1 = No brake, no limits 1 = None
 2 = No brake, no limits 2 = None 2 = 24V brake, no limits (ballscrew only)

Protection Options (same as Kinetix MPAS options)

S = Covered with strip seals (applies to all Kinetix MPMA linear stages)

Z-axis 10s of mm

0 = 0 mm 2 = 20 mm 4 = 40 mm 6 = 60 mm 8 = 80 mm
 1 = 10 mm 3 = 30 mm 5 = 50 mm 7 = 70 mm 9 = 90 mm

Z-axis 100s of mm

A = 0 mm C = 200 mm E = 400 mm
 B = 100 mm D = 300 mm F = 500 mm

Y-axis 10s of mm

0 = 0 mm 2 = 20 mm 4 = 40 mm 6 = 60 mm 8 = 80 mm
 1 = 10 mm 3 = 30 mm 5 = 50 mm 7 = 70 mm 9 = 90 mm

Y-axis 100s of mm

A = 0 mm C = 200 mm E = 400 mm G = 600 mm
 B = 100 mm D = 300 mm F = 500 mm

X-axis 10s of mm

0 = 0 mm 2 = 20 mm 4 = 40 mm 6 = 60 mm 8 = 80 mm
 1 = 10 mm 3 = 30 mm 5 = 50 mm 7 = 70 mm 9 = 90 mm

X-axis 100s of mm

A = 0 mm C = 200 mm E = 400 mm G = 600 mm I = 800 mm
 B = 100 mm D = 300 mm F = 500 mm H = 700 mm J = 900 mm

Kinetix MPAS Linear Stage

X-axis (base)

B = MPAS-x9xxxK/L-ALMS2x
 C = MPAS-x9xxxK/L-ALMS2x
 D = MPAS-x9xxxK/L-ALMS2x
 E = MPAS-x8xxxF/E-ALMS2x
 I = MPAS-x8xxx2-V2OS2x
 P = MPAS-x8xxx2-V2OS2x
 Q = MPAS-x9xxx2-V2OS2x

Y-axis (secondary)

B = MPAS-x8xxxF/E-ALMS2x
 C = MPAS-x9xxxK/L-ALMS2x
 D = None
 E = None
 I = None
 P = MPAS-x8xxx2-V2OS2x
 Q = MPAS-x8xxx2-V2OS2x

Z-axis (secondary)

B = None
 C = None
 D = MPAS-x6xxx2-V2OS4x
 E = MPAS-x6xxx2-V2OS4x
 I = MPAS-x6xxx2-V2OS4x
 P = None
 Q = None

Configuration

A = Center stacked XY
 B = Center stacked XZ
 C = Cartesian stacked XY (left-side cantilever)

Voltage Class

A = 200V
 B = 400V

Actuator Type

MA = Actuator, multi-axis linear stage

Actuator Series

MP = Kinetix MP

Kinetix MPMA Multi-axis Linear Stage System Combinations

The Kinetix MPMA multi-axis stages are based on the individual Kinetix MPAS stages, so the Kinetix MPAS force-velocity system performance specifications also apply to the Kinetix MPMA stages. For the Kinetix MPAS linear stage performance specifications with compatible servo drives, refer to the drive system publication for your servo drive family.

Kinetix MPMA multi-axis stages are comprised of custom Kinetix MPAS stages. This is due to the different cable management requirements for stacked-stage assemblies. Additionally, the Kinetix MPAS individual stage identifier embedded in the Kinetix MPMA catalog number does not correspond directly to the Kinetix MPAS catalog number used in the system combinations.

Kinetix MPAS Stage Identifier

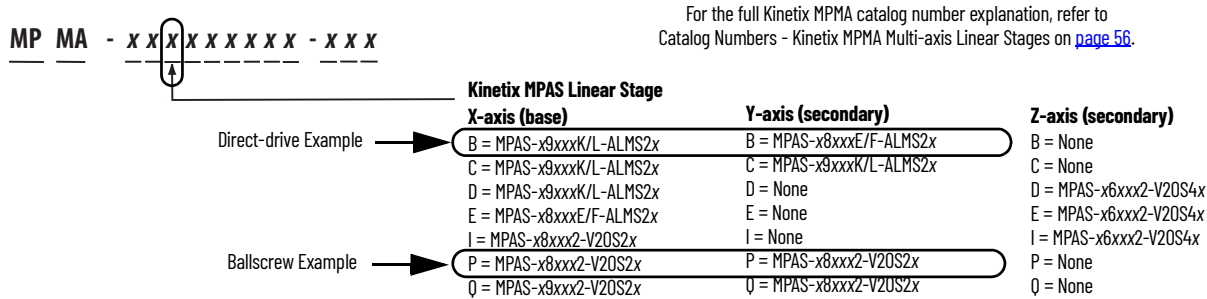

MPAS-xxxxxx-ALM Direct-drive Linear Stage

Follow this example to determine the Kinetix MPAS stages for MPMA-AABC0COA0-S1C multi-axis stages:

- Replace the Voltage Rating designator (x) with A (200V-class) or B (400V-class).
- Replace the Mechanical Drive/Motor Type designator.
 - Replace (K/L) with K if 200V-class or L if 400V-class
 - Replace (E/F) with E if 200V-class or F if 400V-class
- Replace the Cable designator (x), with the direct-drive standard C option.
- In this example: X-axis = MPAS-x9xxxK/L-ALMS2 and Y-axis = MPAS-x8xxxE/F-ALMS2.
 - X-axis stage = MPAS-A9xxxK-ALMS2C
 - Y-axis stage = MPAS-A8xxxE-ALMS2C

MPAS-xxxxxx-Vxx Ballscrew Linear Stage

Follow this example to determine the Kinetix MPAS stages for MPMA-BAPB8B8A0-S1C multi-axis stages:

- Replace the Voltage Rating designator (x) with A (200V-class) or B (400V-class).
- Holding brake (4) or no brake (2) option does not affect system performance.
- In this example: X-axis = MPAS-x8xxx2-V2OS2x and Y-axis = MPAS-x8xxx2-V2OS2x.
 - X-axis stage = MPAS-B8xxx2-V2OSxA
 - Y-axis stage = MPAS-B8xxx2-V2OSxA

Kinetix MPMA Multi-axis Linear Stage Accessory Kits

- Cable track module replacement kits
- Strip seal replacement kits
- Top cover kits (for Y or Z-axis only)
- Side cover kits
- Coupling kits (for Y or Z-axis only)
- Tee-nut kit (package of 10)
- Tee-nut bar kit
- Grease gun kit
- Grease replacement cartridge
- Rotary servo motor (for Y or Z-axis only)

Accessory Kits Common to All Multi-axis Linear Stages

Linear Stage Cat. No.	Description	Accessory Cat. No.
MPAS-A/Bxxxx	Kit, grease gun for all integrated linear stages.	MPAS-GPUMP
	Grease gun refill cartridge for all integrated linear stages.	MPAS-CART
MPAS-A6xxx, MPAS-B6xxx	Kit, Tee-nuts (10 per package).	MPAS-6-TNUT
MPAS-A8xxx, MPAS-B8xxx		MPAS-8-TNUT
MPAS-A9xxx, MPAS-B9xxx		MPAS-9-TNUT

Accessory Kits for Multi-axis Direct-drive Linear Stages

Refer to on [page 38](#) for accessory kit descriptions and catalog numbers.

Accessory Kits for Multi-axis Ballscrew Linear Stages

Refer to Accessory Kits for Single-axis Ballscrew Linear Stages on [page 39](#) for accessory kit descriptions and catalog numbers.

Accessory Kits for Stacked Cable Modules

Accessory Kits for Center Stacked X/Y Cable Modules

Multi-axis Linear Stage Cat. No.	Description	Accessory Cat. No.
MPMA-xABC0C0A0-xxx	Cable track module for MPMA-xAB series X/Y center stacked stages	MPMA-xABC0C0A0-CBL
MPMA-xABC6C6A0-xxx		MPMA-xABC6C6A0-CBL
MPMA-xABD2D2A0-xxx		MPMA-xABD2D2A0-CBL
MPMA-xABD8D8A0-xxx		MPMA-xABD8D8A0-CBL
MPMA-xABE4E4A0-xxx		MPMA-xABE4E4A0-CBL
MPMA-xABF6F6A0-xxx		MPMA-xABF6F6A0-CBL
MPMA-xACB4B4A0-xxx	Cable track module for MPMA-xAC series X/Y center stacked stages	MPMA-xACB4B4A0-CBL
MPMA-xACC0C0A0-xxx		MPMA-xACC0C0A0-CBL
MPMA-xACC6C6A0-xxx		MPMA-xACC6C6A0-CBL
MPMA-xACD2D2A0-xxx		MPMA-xACD2D2A0-CBL
MPMA-xAPB8B8A0-xxx	Cable track module for MPMA-xAP series X/Y center stacked stages	MPMA-xAPB8B8A0-CBL
MPMA-xAPC4C4A0-xxx		MPMA-xAPC4C4A0-CBL
MPMA-xAPD0D0A0-xxx		MPMA-xAPD0D0A0-CBL
MPMA-xAPE2E2A0-xxx		MPMA-xAPE2E2A0-CBL
MPMA-xAPG6G6A0-xxx		MPMA-xAPG6G6A0-CBL

Accessory Kits for Cartesian Stacked X/Y Cable Modules

Multi-axis Linear Stage Cat. No.	Description	Accessory Cat. No.
MPMA-xCBD2D2A0-xxx	Cable track module for MPMA-xCB series X/Y cartesian stacked stages	MPMA-xCBD2D2A0-CBL
MPMA-xCBE4D2A0-xxx		MPMA-xCBE4D2A0-CBL
MPMA-xCBE4E4A0-xxx		MPMA-xCBE4E4A0-CBL
MPMA-xCBF6E4A0-xxx		MPMA-xCBF6E4A0-CBL
MPMA-xCBG8E4A0-xxx		MPMA-xCBG8E4A0-CBL
MPMA-xCBG8F6A0-xxx		MPMA-xCBG8F6A0-CBL
MPMA-xCBIOF6A0-xxx		MPMA-xCBIOF6A0-CBL
MPMA-xCBJ2F6A0-xxx		MPMA-xCBJ2F6A0-CBL
MPMA-xCQD0D0A0-xxx	Cable track module for MPMA-xCQ series X/Y cartesian stacked stages	MPMA-xCQD0D0A0-CBL
MPMA-xCQE2D0A0-xxx		MPMA-xCQE2D0A0-CBL
MPMA-xCQE2E2A0-xxx		MPMA-xCQE2E2A0-CBL
MPMA-xCQG6E2A0-xxx		MPMA-xCQG6E2A0-CBL
MPMA-xCQG6G6A0-xxx		MPMA-xCQG6G6A0-CBL
MPMA-xCQH8G6A0-xxx		MPMA-xCQH8G6A0-CBL
MPMA-xCQJOG6A0-xxx		MPMA-xCQJOG6A0-CBL

Accessory Kits for Center Stacked X/Z Cable Modules

Multi-axis Linear Stage Cat. No.	Description	Accessory Cat. No.
MPMA-xBDD2A0B8-xxx	Cable track module for MPMA-xBD series X/Z center stacked stages	MPMA-xBDD2A0B8-CBL
MPMA-xBDD2A0D0-xxx		MPMA-xBDD2A0D0-CBL
MPMA-xBDE4A0B8-xxx		MPMA-xBDE4A0B8-CBL
MPMA-xBDE4A0D0-xxx		MPMA-xBDE4A0D0-CBL
MPMA-xBDE4A0E2-xxx		MPMA-xBDE4A0E2-CBL
MPMA-xBDG8A0B8-xxx		MPMA-xBDG8A0B8-CBL
MPMA-xBDG8A0D0-xxx		MPMA-xBDG8A0D0-CBL
MPMA-xBDG8A0E2-xxx		MPMA-xBDG8A0E2-CBL
MPMA-xBDIOA0B8-xxx		MPMA-xBDIOA0B8-CBL
MPMA-xBDIOA0D0-xxx		MPMA-xBDIOA0D0-CBL
MPMA-xBDIOA0E2-xxx		MPMA-xBDIOA0E2-CBL
MPMA-xBDJ2A0D0-xxx		MPMA-xBDJ2A0D0-CBL
MPMA-xBDJ2A0E2-xxx		MPMA-xBDJ2A0E2-CBL
MPMA-xBDJ2A0F4-xxx		MPMA-xBDJ2A0F4-CBL
MPMA-xBED2A0B8-xxx		Cable track module for MPMA-xBE series X/Z center stacked stages
MPMA-xBED2A0D0-xxx	MPMA-xBED2A0D0-CBL	
MPMA-xBEE4A0B8-xxx	MPMA-xBEE4A0B8-CBL	
MPMA-xBEE4A0D0-xxx	MPMA-xBEE4A0D0-CBL	
MPMA-xBEG8A0B8-xxx	MPMA-xBEG8A0B8-CBL	
MPMA-xBEG8A0D0-xxx	MPMA-xBEG8A0D0-CBL	
MPMA-xBID0A0B8-xxx	Cable track module for MPMA-xBI series X/Z center stacked stages	MPMA-xBID0A0B8-CBL
MPMA-xBID0A0D0-xxx		MPMA-xBID0A0D0-CBL
MPMA-xBIE2A0B8-xxx		MPMA-xBIE2A0B8-CBL
MPMA-xBIE2A0D0-xxx		MPMA-xBIE2A0D0-CBL
MPMA-xBIG6A0B8-xxx		MPMA-xBIG6A0B8-CBL
MPMP-xBIG6A0D0-xxx		MPMP-xBIG6A0D0-CBL

Mounting Bar Accessory Kits for Multi-axis X-axis Linear Stages

Multi-axis Linear Stage Cat. No.	Description	Accessory Cat. No.
MPMA-xxxB4xxx-xxx	Mounting bar for X-axis having B4 travel	MPAS-TBAR-B4
MPMA-xxxB8xxx-xxx	Mounting bar for X-axis having B8 travel	MPAS-TBAR-B8
MPMA-xxxC0xxx-xxx	Mounting bar for X-axis having C0 travel	MPAS-TBAR-C0
MPMA-xxxC4xxx-xxx	Mounting bar for X-axis having C4 travel	MPAS-TBAR-C4
MPMA-xxxC6xxx-xxx	Mounting bar for X-axis having C6 travel	MPAS-TBAR-C6
MPMA-xxxD0xxx-xxx	Mounting bar for X-axis having D0 travel	MPAS-TBAR-D0
MPMA-xxxD2xxx-xxx	Mounting bar for X-axis having D2 travel	MPAS-TBAR-D2
MPMA-xxxD8xxx-xxx	Mounting bar for X-axis having D8 travel	MPAS-TBAR-D8
MPMA-xxxE2xxx-xxx	Mounting bar for X-axis having E2 travel	MPAS-TBAR-E2
MPMA-xxxE4xxx-xxx	Mounting bar for X-axis having E4 travel	MPAS-TBAR-E4
MPMA-xxxF6xxx-xxx	Mounting bar for X-axis having F6 travel	MPAS-TBAR-F6
MPMA-xxxG6xxx-xxx	Mounting bar for X-axis having G6 travel	MPAS-TBAR-G6
MPMA-xxxG8xxx-xxx	Mounting bar for X-axis having G8 travel	MPAS-TBAR-G8
MPMA-xxxH8xxx-xxx	Mounting bar for X-axis having H8 travel	MPAS-TBAR-H8
MPMA-xxxI0xxx-xxx	Mounting bar for X-axis having I0 travel	MPAS-TBAR-I0
MPMA-xxxJ0xxx-xxx	Mounting bar for X-axis having J0 travel	MPAS-TBAR-J0
MPMA-xxxJ2xxx-xxx	Mounting bar for X-axis having J2 travel	MPAS-TBAR-J2

Technical Specifications - Kinetix MPMA Multi-axis Linear Stages

Kinetix MPMA Multi-axis Linear Stage Life Specifications

Attribute	Value
Strip seal	10,000,000 cycles or 10,000 km min life in clean, dry, noncontaminating environment.
Cable track module	10,000,000 cycles minimum life.
Mechanical stop bumper	56.49 N•m (500 lb•in) potential energy.

Kinetix MPMA Multi-axis Linear Stages Motor Brake Specifications

Multi-axis Linear Stage Cat. No.	Backlash, max (brake engaged) µm (in.)	Holding Force N (lb)	Coil Current at 24V DC A	Brake Response Time		
				Release ms	Engage (by using external arc suppression device)	
					MOV ms	Diode ms
MPAS-A/Bxxxx2-V20SxA	100 (0.004)	1294 (291)	0.46...0.56	58	20	42

Dimensions - Kinetix MPMA Multi-axis Linear Stages

MPMA-xABxxxxxx-xxx Product Specifications and Dimensions

These specifications apply to center stacked X/Y stages with 250 mm frame linear motor driven X-axis and 200 mm frame linear motor driven Y-axis. Maximum payload is 15 kg (33.1 lb). For heavier loads, contact your Rockwell Automation sales representative.



MPMA-xABxxxxxx-xxx Product Specifications

Multi-axis Linear Stage Cat. No.	Travel mm (in.)			Encoder Type			Bi-directional Repeatability (µm)			Weight, approx kg (lb)		
	X-axis	Y-axis	Z-axis	X-axis	Y-axis	Z-axis	X-axis	Y-axis	Z-axis			
MPMA-xABC0C0A0-S1C	200 (7.9)									56.4 (124.1)		
MPMA-xABC6C6A0-S1C	260 (10.2)									59.2 (130.2)		
MPMA-xABD2D2A0-S1C	320 (12.6)			5 micron resolution incremental magnetic linear encoder (direct-drive only)			15	15		62.1 (136.6)		
MPMA-xABD8D8A0-S1C	380 (15.0)											64.4 (141.7)
MPMA-xABE4E4A0-S1C	440 (17.3)											67.3 (148.1)
MPMA-xABF6F6A0-S1C	560 (22.0)											73.1 (160.8)

MPMA-xABxxxxxx-xxx Product Dimensions

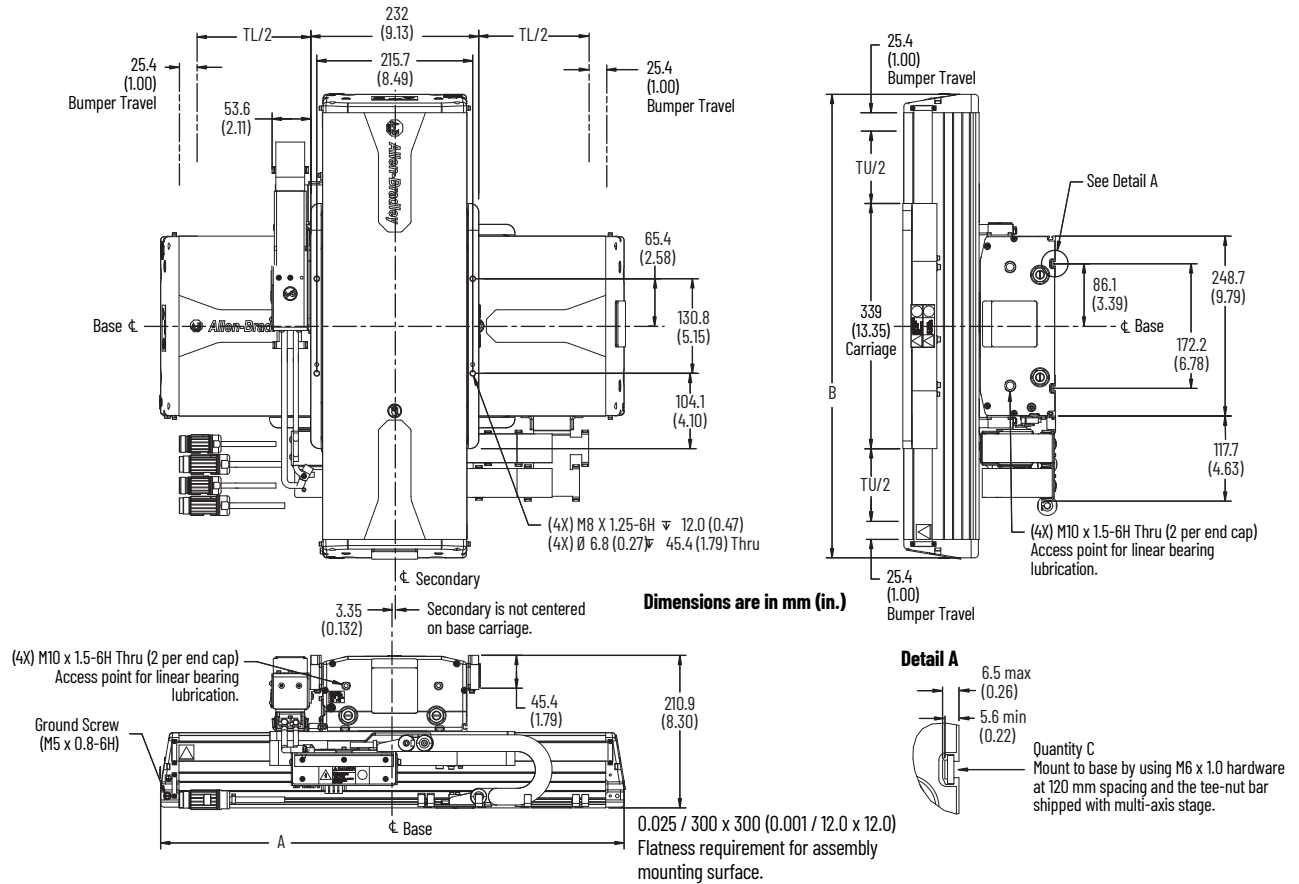

Multi-axis Linear Stage Cat. No.	A Stage Length (X-axis)	TL Travel (X-axis)	B Stage Length (Y-axis)	TU Travel (Y-axis)	C Mounting Locations (X-axis)
	mm (in.)	mm (in.)	mm (in.)	mm (in.)	Qty
MPMA-AABC0C0A0-S1C	641 (25.2)	200 (7.9)	641 (25.2)	200 (7.9)	10
MPMA-AABC6C6A0-S1C	701 (27.6)	260 (10.2)	701 (27.6)	260 (10.2)	12
MPMA-AABD2D2A0-S1C	761 (30.0)	320 (12.6)	761 (30.0)	320 (12.6)	14
MPMA-AABD8D8A0-S1C	821 (32.3)	380 (15.0)	821 (32.3)	380 (15.0)	16
MPMA-AABE4E4A0-S1C	881 (34.7)	440 (17.3)	881 (34.7)	440 (17.3)	10
MPMA-AABF6F6A0-S1C	1001 (39.4)	560 (22.0)	1001 (39.4)	560 (22.0)	12
MPMA-BABC0C0A0-S1C	641 (25.2)	200 (7.9)	641 (25.2)	200 (7.9)	14
MPMA-BABC6C6A0-S1C	701 (27.6)	260 (10.2)	701 (27.6)	260 (10.2)	16
MPMA-BABD2D2A0-S1C	761 (30.0)	320 (12.6)	761 (30.0)	320 (12.6)	10
MPMA-BABD8D8A0-S1C	821 (32.3)	380 (15.0)	821 (32.3)	380 (15.0)	12
MPMA-BABE4E4A0-S1C	881 (34.7)	440 (17.3)	881 (34.7)	440 (17.3)	14
MPMA-BABF6F6A0-S1C	1001 (39.4)	560 (22.0)	1001 (39.4)	560 (22.0)	16

Actuators are designed to metric dimensions. Inch dimensions are approximate conversions from millimeters. Dimensions without tolerances are for reference.

MPMA-xACxxxxxx-xxx Product Specifications and Dimensions

These specifications apply to center stacked X/Y stages with 250 mm frame linear motor driven X-axis and 250 mm frame linear motor driven Y-axis. Maximum payload is 20 kg (44.0 lb). For heavier loads, contact your Rockwell Automation sales representative.



MPMA-xACxxxxxx-xxx Product Specifications

Multi-axis Linear Stage Cat. No.	Travel mm (in.)			Encoder Type			Bi-directional Repeatability (μm)			Weight, approx kg (lb)
	X-axis	Y-axis	Z-axis	X-axis	Y-axis	Z-axis	X-axis	Y-axis	Z-axis	
MPMA-xACB4B4A0-S1C	140 (5.5)			5 micron resolution incremental magnetic linear encoder (direct-drive only)			15	15	-	62.2 (136.8)
MPMA-xACC0C0A0-S1C	200 (7.9)				66.0 (145.2)					
MPMA-xACC6C6A0-S1C	260 (10.2)				69.2 (152.2)					
MPMA-xACD2D2A0-S1C	320 (12.6)				72.2 (158.8)					

MPMA-xACxxxxxx-xxx Product Dimensions

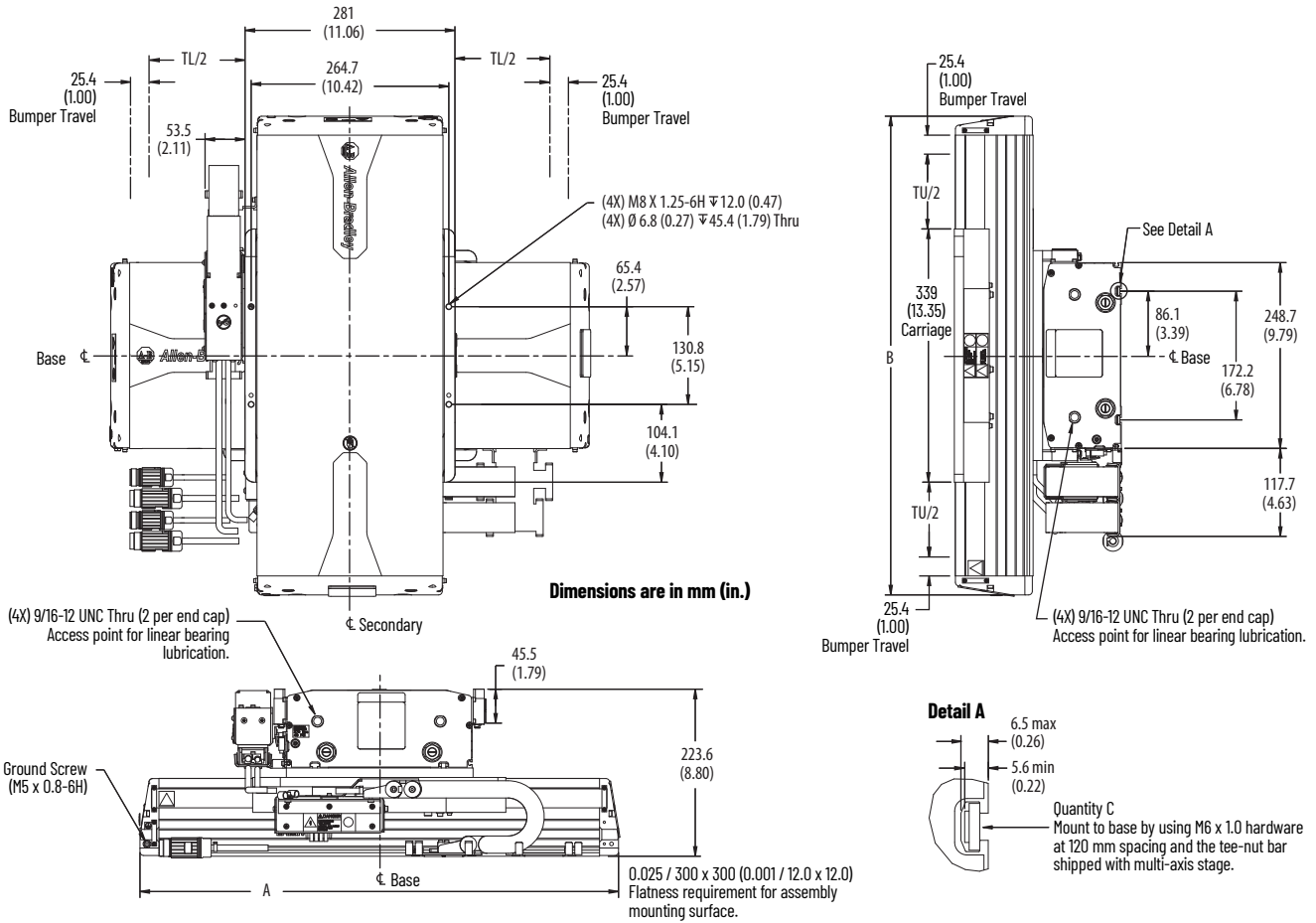

Multi-axis Linear Stage Cat. No.	A Stage Length (X-axis)	TL Travel (X-axis)	B Stage Length (Y-axis)	TU Travel (Y-axis)	C Mounting Locations (X-axis)
	mm (in.)	mm (in.)	mm (in.)	mm (in.)	Qty
MPMA-AACB4B4AO-S1C	581 (22.9)	140 (5.5)	581 (22.9)	140 (5.5)	10
MPMA-AACC0COAO-S1C	641 (25.2)	200 (7.9)	641 (25.2)	200 (7.9)	
MPMA-AACC6C6AO-S1C	701 (27.6)	260 (10.2)	701 (27.6)	260 (10.2)	12
MPMA-AACD2D2AO-S1C	761 (30.0)	320 (12.6)	761 (30.0)	320 (12.6)	
MPMA-BACB4B4AO-S1C	581 (22.9)	140 (5.5)	581 (22.9)	140 (5.5)	10
MPMA-BACC0COAO-S1C	641 (25.2)	200 (7.9)	641 (25.2)	200 (7.9)	
MPMA-BACC6C6AO-S1C	701 (27.6)	260 (10.2)	701 (27.6)	260 (10.2)	12
MPMA-BACD2D2AO-S1C	761 (30.0)	320 (12.6)	761 (30.0)	320 (12.6)	

Actuators are designed to metric dimensions. Inch dimensions are approximate conversions from millimeters. Dimensions without tolerances are for reference.

MPMA-xAPxxxxxx-xxx Product Specifications and Dimensions

These specifications apply to center stacked X/Y stages with 200 mm frame ballscrew driven X-axis and 200 mm frame ballscrew driven Y-axis. Maximum payload is 20 kg (44.0 lb). For heavier loads, contact your Rockwell Automation sales representative.



Multi-axis Linear Stage Cat. No.	Travel mm (in.)			Encoder Type			Bi-directional Repeatability (μm)			Weight, approx kg (lb)
	X-axis	Y-axis	Z-axis	X-axis	Y-axis	Z-axis	X-axis	Y-axis	Z-axis	
MPMA-xAPB8B8A0-S1C	180 (7.1)			Multi-turn high resolution encoder absolute feedback, 128 cycle/rev. (ballscrew only)			60	60	-	36.1 (79.4)
MPMA-xAPC4C4A0-S1C	240 (9.4)				37.9 (83.4)					
MPMA-xAPD0D0A0-S1C	300 (11.8)				39.9 (87.8)					
MPMA-xAPE2E2A0-S1C	420 (16.5)				43.9 (96.6)					
MPMA-xAPG6G6A0-S1C	660 (26.0)				51.5 (113.3)					

MPMA-xAPxxxxxx-xxx Product Dimensions

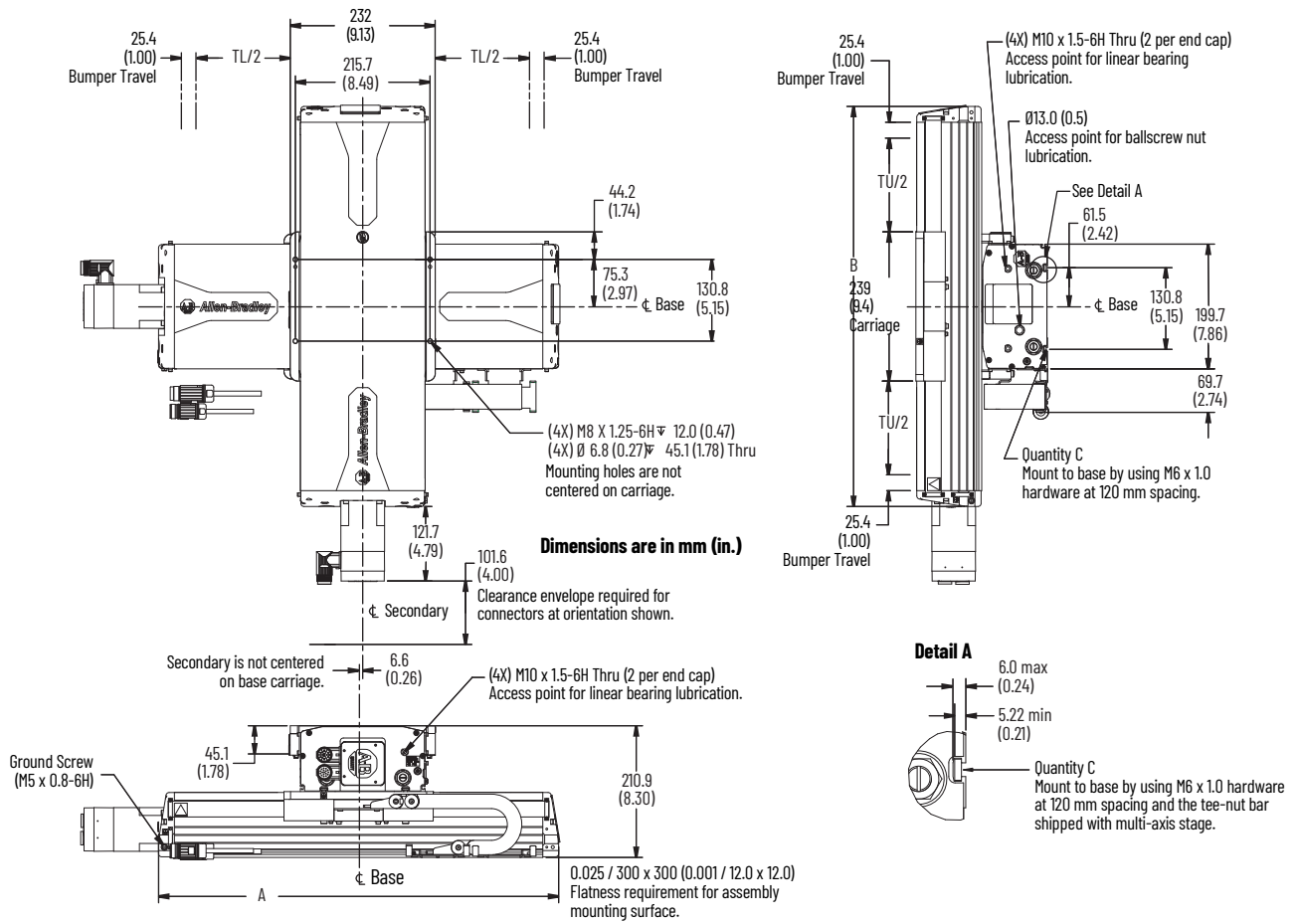

Multi-axis Linear Stage Cat. No.	A Stage Length (X-axis)	TL Travel (X-axis)	B Stage Length (Y-axis)	TU Travel (Y-axis)	C Mounting Locations (X-axis)
	mm (in.)	mm (in.)	mm (in.)	mm (in.)	Qty
MPMA-AAPB8B8A0-S1C	521 (20.5)	180 (7.1)	521 (20.5)	180 (7.1)	8
MPMA-AAPC4C4A0-S1C	581 (22.9)	240 (9.4)	581 (22.9)	240 (9.4)	10
MPMA-AAPD0D0A0-S1C	641 (25.2)	300 (11.8)	641 (25.2)	300 (11.8)	
MPMA-AAPE2E2A0-S1C	761 (30.0)	420 (16.5)	761 (30.0)	420 (16.5)	12
MPMA-AAPG6G6A0-S1C	1001 (39.4)	660 (26.0)	1001 (39.4)	660 (26.0)	16
MPMA-BAPB8B8A0-S1C	521 (20.5)	180 (7.1)	521 (20.5)	180 (7.1)	8
MPMA-BAPC4C4A0-S1C	581 (22.9)	240 (9.4)	581 (22.9)	240 (9.4)	10
MPMA-BAPD0D0A0-S1C	641 (25.2)	300 (11.8)	641 (25.2)	300 (11.8)	
MPMA-BAPE2E2A0-S1C	761 (30.0)	420 (16.5)	761 (30.0)	420 (16.5)	12
MPMA-BAPG6G6A0-S1C	1001 (39.4)	660 (26.0)	1001 (39.4)	660 (26.0)	16

Actuators are designed to metric dimensions. Inch dimensions are approximate conversions from millimeters. Dimensions without tolerances are for reference.

MPMA-xCBxxxxxx-xxx Product Specifications and Dimensions

These specifications apply to cartesian stacked X/Y stages with 250 mm frame linear motor driven X-axis and 200 mm frame linear motor driven Y-axis. Maximum payload is 20 kg (44.0 lb). For heavier loads, contact your Rockwell Automation sales representative.



MPMA-xCBxxxxxx-xxx Product Specifications

Multi-axis Linear Stage Cat. No.	Travel mm (in.)			Encoder Type			Bi-directional Repeatability (μm)			Weight, approx kg (lb)
	X-axis	Y-axis	Z-axis	X-axis	Y-axis	Z-axis	X-axis	Y-axis	Z-axis	
MPMA-xCBD2D2AO-S1C	320 (12.6)	320 (12.6)	-	5 micron resolution incremental magnetic linear encoder (direct-drive only)	-	-	15	15	-	69.7 (153.3)
MPMA-xCBE4D2AO-S1C	440 (17.3)									72.7 (159.9)
MPMA-xCBE4E4AO-S1C		74.9 (164.7)								
MPMA-xCBF6E4AO-S1C	440 (17.3)	78.4 (172.4)								
MPMA-xCBG8E4AO-S1C	680 (26.8)	81.4 (179.0)								
MPMA-xCBG8F6AO-S1C		83.7 (184.1)								
MPMA-xCBIOF6AO-S1C	800 (31.5)	560 (22.0)								87.2 (191.8)
MPMA-xCBJ2F6AO-S1C	920 (36.2)	90.3 (198.6)								

MPMA-xCBxxxxxx-xxx Product Dimensions

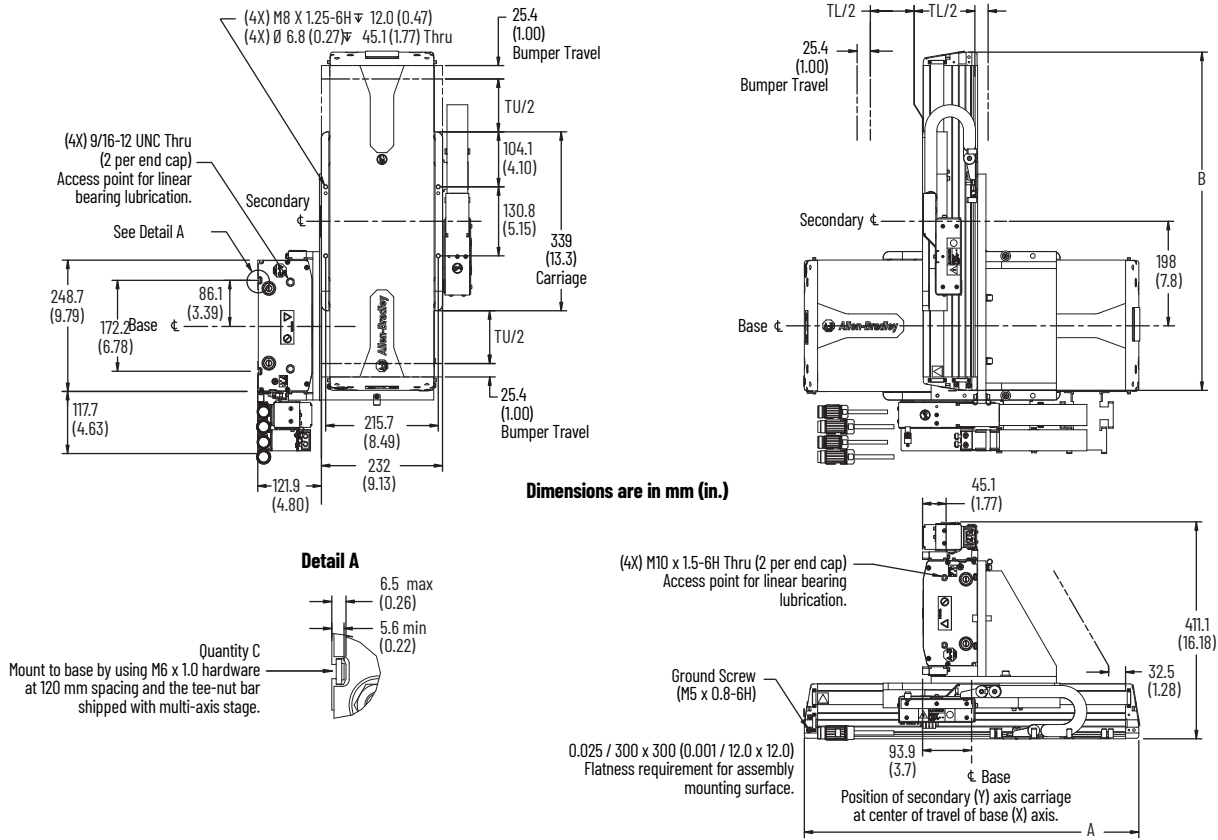

Multi-axis Linear Stage Cat. No.	A Stage Length (X-axis) mm (in.)	TL Travel (X-axis) mm (in.)	B Stage Length (Y-axis) mm (in.)	TU Travel (Y-axis) mm (in.)	C Mounting Locations (X-axis) Qty
MPMA-ACBD2D2A0-S1C	761 (30.0)	320 (12.6)	761 (30.0)	320 (12.6)	12
MPMA-ACBE4D2A0-S1C	881 (34.7)	440 (17.3)			14
MPMA-ACBE4E4A0-S1C	1001 (39.4)	560 (22.0)	881 (34.7)	440 (17.3)	16
MPMA-ACBF6E4A0-S1C					18
MPMA-ACBG8E4A0-S1C	1121 (44.1)	680 (26.8)	1001 (39.4)	560 (22.0)	20
MPMA-ACBG8F6A0-S1C	1241 (48.9)	800 (31.5)			22
MPMA-ACBJ2F6A0-S1C	1361 (53.6)	920 (36.2)	761 (30.0)	320 (12.6)	12
MPMA-BCBD2D2A0-S1C	761 (30.0)	320 (12.6)			14
MPMA-BCBE4D2A0-S1C	881 (34.7)	440 (17.3)	881 (34.7)	440 (17.3)	16
MPMA-BCBE4E4A0-S1C	1001 (39.4)	560 (22.0)			18
MPMA-BCBF6E4A0-S1C	1121 (44.1)	680 (26.8)	1001 (39.4)	560 (22.0)	20
MPMA-BCBG8E4A0-S1C	1241 (48.9)	800 (31.5)			22
MPMA-BCBG8F6A0-S1C	1361 (53.6)	920 (36.2)			

Actuators are designed to metric dimensions. Inch dimensions are approximate conversions from millimeters. Dimensions without tolerances are for reference.

MPMA-xCQxxxxxx-xxx Product Specifications and Dimensions

These specifications apply to cartesian stacked X/Y stages with 250 mm frame ballscrew driven X-axis and 200 mm frame ballscrew driven Y-axis. Maximum payload is 25 kg (55.1 lb). For heavier loads, contact your Rockwell Automation sales representative.



MPMA-xCQxxxxxx-xxx Product Specifications

Multi-axis Linear Stage Cat. No.	Travel mm (in.)			Encoder Type			Bi-directional Repeatability (μm)			Weight, approx kg (lb)
	X-axis	Y-axis	Z-axis	X-axis	Y-axis	Z-axis	X-axis	Y-axis	Z-axis	
MPMA-xCQD0D0AO-S1C	300 (11.8)	300 (11.8)	-	Multi-turn high resolution encoder absolute feedback, 128 cycle/rev. (ballscrew only)	-	-	60	60	-	51.7 (113.7)
MPMA-xCQE2D0AO-S1C	420 (16.5)									54.3 (119.4)
MPMA-xCQE2E2AO-S1C		420 (16.5)								56.3 (123.8)
MPMA-xCQG6E2AO-S1C	660 (26.0)									61.4 (135.0)
MPMA-xCQG6G6AO-S1C		660 (26.0)								65.2 (143.4)
MPMA-xCQH8G6AO-S1C	780 (30.7)									67.7 (148.9)
MPMA-xCQJ0G6AO-S1C	900 (35.4)	70.2 (154.4)								

MPMA-xCQxxxxxx-xxx Product Dimensions

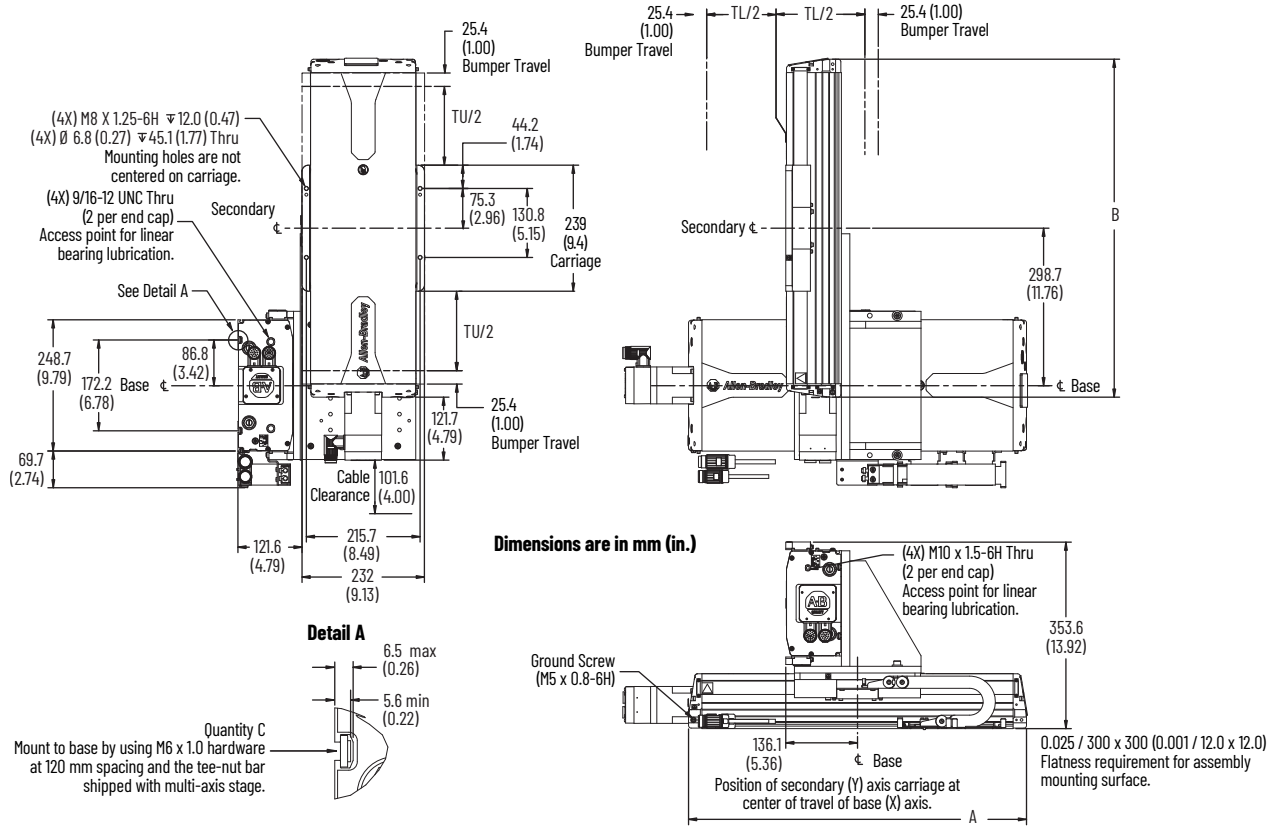

Multi-axis Linear Stage Cat. No.	A Stage Length (X-axis)	TL Travel (X-axis)	B Stage Length (Y-axis)	TU Travel (Y-axis)	C Mounting Locations (X-axis)
	mm (in.)	mm (in.)	mm (in.)	mm (in.)	Qty
MPMA-ACQD0DOAO-S1C	641 (25.2)	300 (11.8)	641 (25.2)	300 (11.8)	10
MPMA-ACQE2DOAO-S1C	761 (30.0)	420 (16.5)			12
MPMA-ACQE2E2AO-S1C	1001 (39.4)	660 (26.0)	761 (30.0)	420 (16.5)	16
MPMA-ACQG6E2AO-S1C			1001 (39.4)		
MPMA-ACQH8G6AO-S1C	1121 (44.1)	780 (30.7)	1001 (39.4)	660 (26.0)	18
MPMA-ACQJOG6AO-S1C	1241 (48.9)	900 (35.4)			20
MPMA-BCQD0DOAO-S1C	641 (25.2)	300 (11.8)	641 (25.2)	300 (11.8)	10
MPMA-BCQE2DOAO-S1C	761 (30.0)	420 (16.5)			12
MPMA-BCQE2E2AO-S1C	1001 (39.4)	660 (26.0)	761 (30.0)	420 (16.5)	16
MPMA-BCQG6E2AO-S1C			1001 (39.4)		
MPMA-BCQH8G6AO-S1C	1121 (44.1)	780 (30.7)	1001 (39.4)	660 (26.0)	18
MPMA-BCQJOG6AO-S1C	1241 (48.9)	900 (35.4)			20

Actuators are designed to metric dimensions. Inch dimensions are approximate conversions from millimeters. Dimensions without tolerances are for reference.

MPMA-xBExxxxxx-xxx Product Specifications and Dimensions

These specifications apply to center stacked X/Z stages with 200 mm frame linear motor driven X-axis and 150 mm frame ballscrew driven Z-axis. Maximum payload is 20 kg (44.0 lb). For heavier loads, contact your Rockwell Automation sales representative.



MPMA-xBExxxxxx-xxx Product Specifications

Multi-axis Linear Stage Cat. No.	Travel mm (in.)			Encoder Type			Bi-directional Repeatability (μ m)			Weight, approx kg (lb)
	X-axis	Y-axis	Z-axis	X-axis	Y-axis	Z-axis	X-axis	Y-axis	Z-axis	
MPMA-xBED2A0B8-S2C	320 (12.6)	-	180 (7.1)	5 micron resolution incremental magnetic linear encoder (direct-drive only)	-	Multi-turn high resolution encoder absolute feedback, 128 cycle/rev. (ballscrew only)	15	-	60	44.5 (98.0)
MPMA-xBED2A0D0-S2C			300 (11.8)							46.2 (101.7)
MPMA-xBEE4A0B8-S2C	440 (17.3)		180 (7.1)							46.7 (102.8)
MPMA-xBEE4A0D0-S2C			300 (11.8)							48.4 (106.6)
MPMA-xBEG8A0B8-S2C	680 (26.8)		180 (7.1)							51.2 (112.7)
MPMA-xBEG8A0D0-S2C			300 (11.8)							52.9 (116.9)

MPMA-xBExxxxxx-xxx Product Dimensions

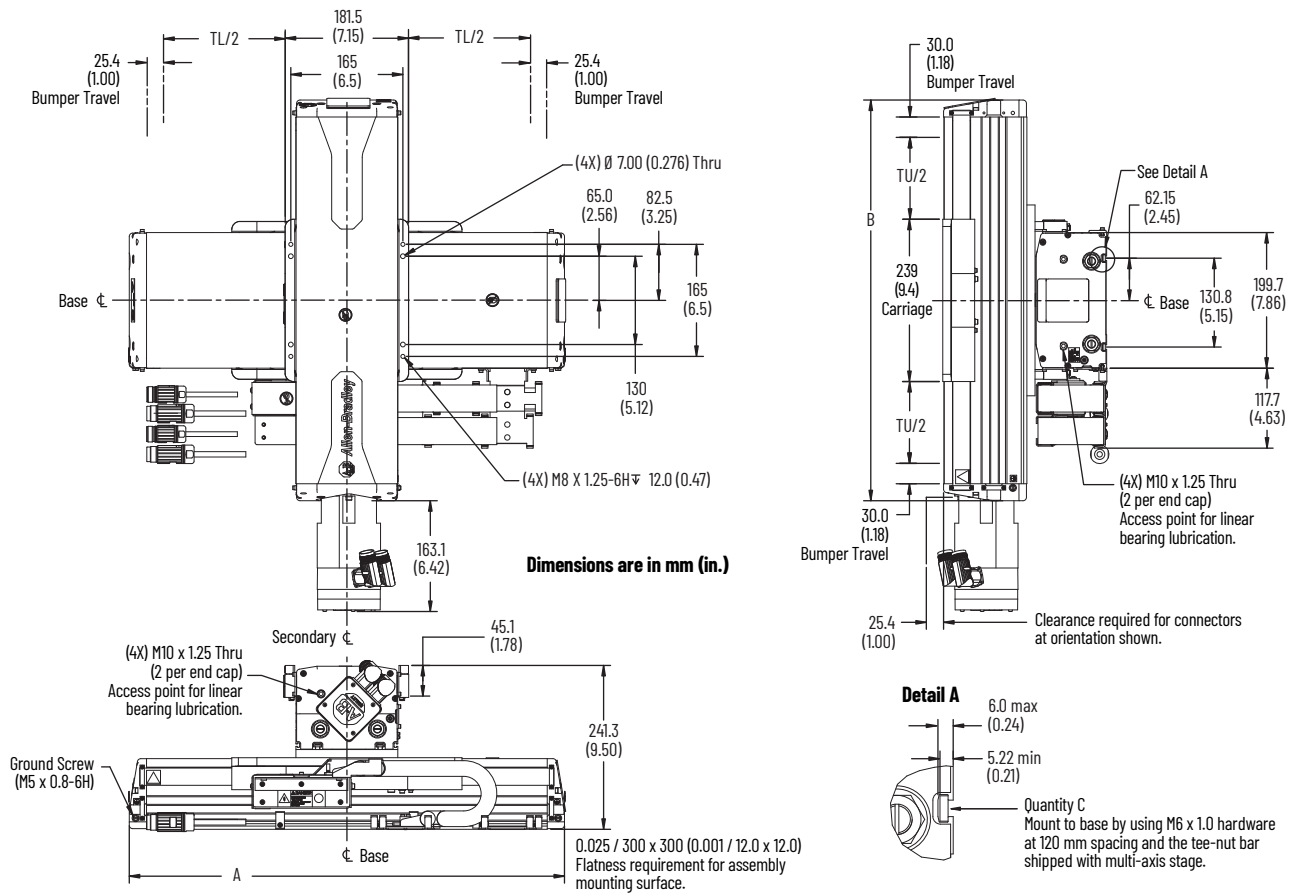

Multi-axis Linear Stage Cat. No.	A Stage Length (X-axis)	TL Travel (X-axis)	B Stage Length (Z-axis)	TU Travel (Z-axis)	C Mounting Locations (X-axis)
	mm (in.)	mm (in.)	mm (in.)	mm (in.)	Qty
MPMA-ABED2A0B8-S2C	761 (30.0)	320 (12.6)	530 (20.9)	180 (7.1)	12
MPMA-ABED2A0D0-S2C			650 (25.6)	300 (11.8)	
MPMA-ABEE4A0B8-S2C	881 (34.7)	440 (17.3)	530 (20.9)	180 (7.1)	14
MPMA-ABEE4A0D0-S2C			650 (25.6)	300 (11.8)	
MPMA-ABEG8A0B8-S2C	1121 (44.1)	680 (26.8)	530 (20.9)	180 (7.1)	18
MPMA-ABEG8A0D0-S2C			650 (25.6)	300 (11.8)	
MPMA-BBED2A0B8-S2C	761 (30.0)	320 (12.6)	530 (20.9)	180 (7.1)	12
MPMA-BBED2A0D0-S2C			650 (25.6)	300 (11.8)	
MPMA-BBEE4A0B8-S2C	881 (34.7)	440 (17.3)	530 (20.9)	180 (7.1)	14
MPMA-BBEE4A0D0-S2C			650 (25.6)	300 (11.8)	
MPMA-BBEG8A0B8-S2C	1121 (44.1)	680 (26.8)	530 (20.9)	180 (7.1)	18
MPMA-BBEG8A0D0-S2C			650 (25.6)	300 (11.8)	

Actuators are designed to metric dimensions. Inch dimensions are approximate conversions from millimeters. Dimensions without tolerances are for reference.

MPMA-xBlxxxxx-xxx Product Specifications and Dimensions

These specifications apply to center stacked X/Z stages with 200 mm frame ballscrew driven X-axis and 150 mm frame ballscrew driven Z-axis. Maximum payload is 25 kg (55.1 lb). For heavier loads, contact your Rockwell Automation sales representative.



MPMA-xBlxxxxx-xxx Product Specifications

Multi-axis Linear Stage Cat. No.	Travel mm (in.)			Encoder Type			Bi-directional Repeatability (μm)			Weight, approx kg (lb)
	X-axis	Y-axis	Z-axis	X-axis	Y-axis	Z-axis	X-axis	Y-axis	Z-axis	
MPMA-xBID0A0B8-S2C	300 (11.8)	-	180 (7.1)	Multi-turn high resolution encoder absolute feedback, 128 cycle/rev. (ballscrew only)	-	Multi-turn high resolution encoder absolute feedback, 128 cycle/rev. (ballscrew only)	60	-	60	37.7 (83.0)
MPMA-xBID0A0D0-S2C			300 (11.8)							39.4 (86.8)
MPMA-xBIE2A0B8-S2C	420 (16.5)		180 (7.1)							39.7 (87.4)
MPMA-xBIE2A0D0-S2C			300 (11.8)							41.4 (91.2)
MPMA-xBIG6A0B8-S2C	660 (26.0)		180 (7.1)							43.5 (95.8)
MPMP-xBIG6A0D0-S2C			300 (11.8)							45.2 (99.5)

MPMA-xBlxxxxx-xxx Product Dimensions

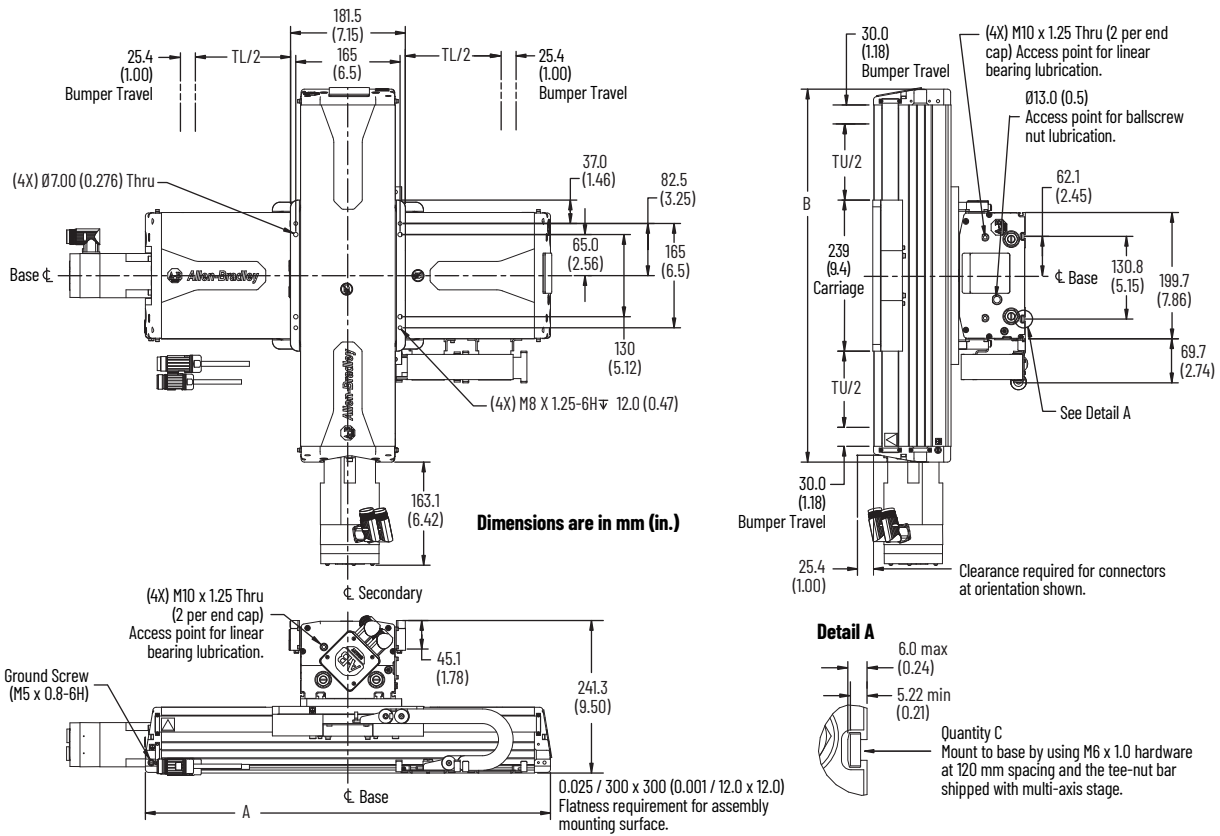

Multi-axis Linear Stage Cat. No.	A Stage Length (X-axis)	TL Travel (X-axis)	B Stage Length (Z-axis)	TU Travel (Z-axis)	C Mounting Locations (X-axis)
	mm (in.)	mm (in.)	mm (in.)	mm (in.)	Qty
MPMA-ABID0A0B8-S2C	641 (25.2)	300 (11.8)	530 (20.9)	180 (7.1)	10
MPMA-ABID0A0D0-S2C			650 (25.6)	300 (11.8)	
MPMA-ABIE2A0B8-S2C	761 (30.0)	420 (16.5)	530 (20.9)	180 (7.1)	12
MPMA-ABIE2A0D0-S2C			650 (25.6)	300 (11.8)	
MPMA-ABIG6A0B8-S2C	1001 (39.4)	660 (26.0)	530 (20.9)	180 (7.1)	16
MPMA-ABIG6A0D0-S2C			650 (25.6)	300 (11.8)	
MPMA-BBID0A0B8-S2C	641 (25.2)	300 (11.8)	530 (20.9)	180 (7.1)	10
MPMA-BBID0A0D0-S2C			650 (25.6)	300 (11.8)	
MPMA-BBIE2A0B8-S2C	761 (30.0)	420 (16.5)	530 (20.9)	180 (7.1)	12
MPMA-BBIE2A0D0-S2C			650 (25.6)	300 (11.8)	
MPMA-BBIG6A0B8-S2C	1001 (39.4)	660 (26.0)	530 (20.9)	180 (7.1)	16
MPMA-BBIG6A0D0-S2C			650 (25.6)	300 (11.8)	

Actuators are designed to metric dimensions. Inch dimensions are approximate conversions from millimeters. Dimensions without tolerances are for reference.

MPMA-xBDxxxxxx-xxx Product Specifications and Dimensions

These specifications apply to center stacked X/Z stages with 250 mm frame linear motor driven X-axis and 150 mm frame ballscrew driven Z-axis. Maximum payload is 20 kg (44.0 lb). For heavier loads, contact your Rockwell Automation sales representative.



MPMA-xBDxxxxxx-xxx Product Specifications

Multi-axis Linear Stage Cat. No.	Travel mm (in.)			Encoder Type			Bi-directional Repeatability (μm)			Weight, approx kg (lb)
	X-axis	Y-axis	Z-axis	X-axis	Y-axis	Z-axis	X-axis	Y-axis	Z-axis	
MPMA-xBDD2A0B8-S2C	320 (12.6)	-	180 (7.1)	5 micron resolution incremental magnetic linear encoder (direct-drive only)	-	Multi-turn high resolution encoder absolute feedback, 128 cycle/rev. (ballscrew only)	15	-	60	52.2 (114.9)
MPMA-xBDD2A0D0-S2C			300 (11.8)							53.9 (118.7)
MPMA-xBDE4A0B8-S2C	440 (17.3)		180 (7.1)							55.2 (121.5)
MPMA-xBDE4A0D0-S2C			300 (11.8)							56.9 (125.3)
MPMA-xBDE4A0E2-S2C			420 (16.5)							58.6 (129.0)
MPMA-xBDG8A0B8-S2C	680 (26.8)		180 (7.1)							61.7 (135.8)
MPMA-xBDG8A0D0-S2C			300 (11.8)							63.4 (139.6)
MPMA-xBDG8A0E2-S2C			420 (16.5)							65.1 (143.3)
MPMA-xBDIOA0B8-S2C	800 (31.5)		180 (7.1)							65.2 (143.5)
MPMA-xBDIOA0D0-S2C			300 (11.8)							66.9 (147.3)
MPMA-xBDIOA0E2-S2C			420 (16.5)							68.6 (151.0)
MPMA-xBDJ2A0D0-S2C	920 (36.2)		300 (11.8)							70.0 (154.1)
MPMA-xBDJ2A0E2-S2C		420 (16.5)	71.7 (157.8)							
MPMA-xBDJ2A0F4-S2C		540 (21.3)	73.5 (161.8)							

MPMA-xBDxxxxxx-xxx Product Dimensions

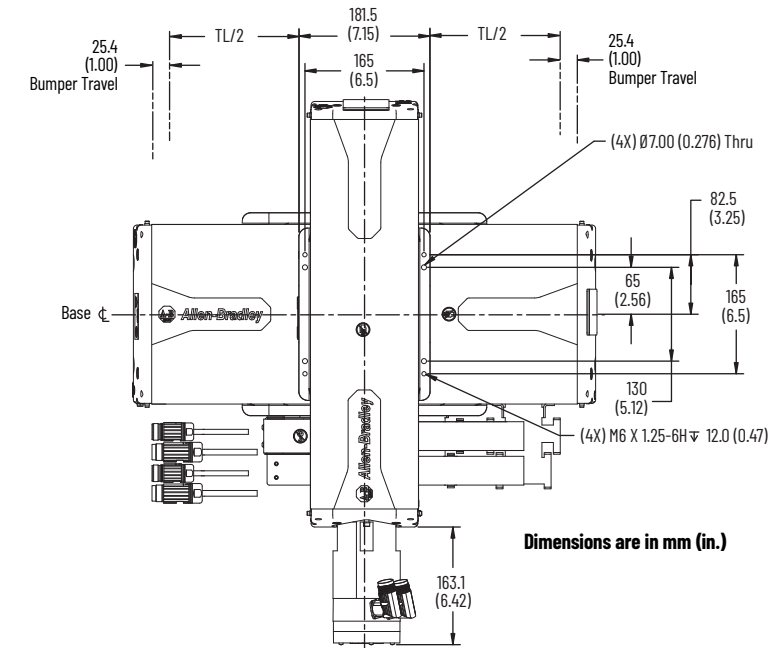

Dimensions are in mm (in.)

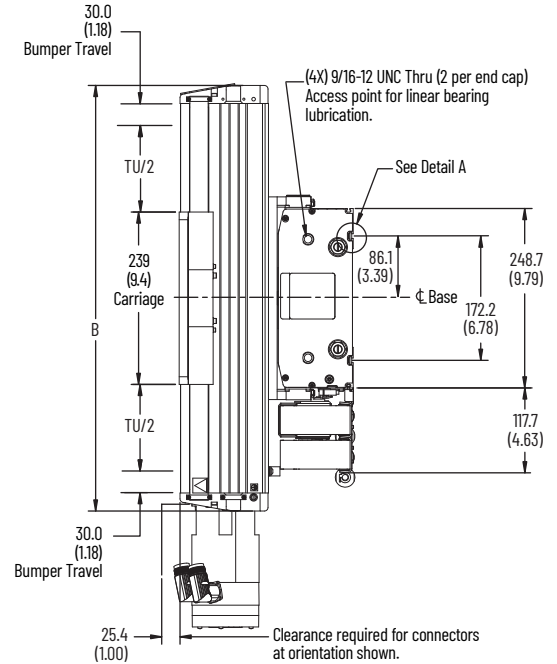
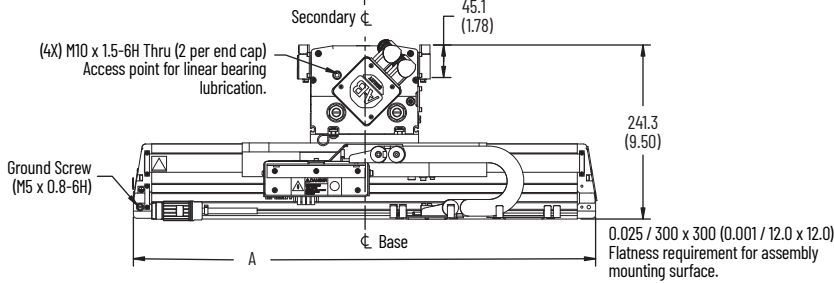

Detail A

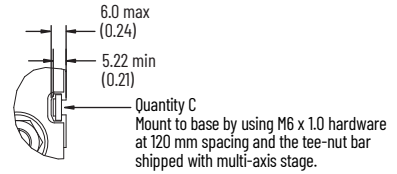

MPMA-xBDxxxxxx-xxx Product Dimensions

Multi-axis Linear Stage Cat. No.	A Stage Length (X-axis)	TL Travel (X-axis)	B Stage Length (Z-axis)	TU Travel (Z-axis)	C Mounting Locations (X-axis)
	mm (in.)	mm (in.)	mm (in.)	mm (in.)	Qty
MPMA-ABDD2A0B8-S2C	761 (30.0)	320 (12.6)	530 (20.9)	180 (7.1)	12
MPMA-ABDD2A0D0-S2C			650 (25.6)	300 (11.8)	
MPMA-ABDE4A0B8-S2C	881 (34.7)	440 (17.3)	530 (20.9)	180 (7.1)	14
MPMA-ABDE4A0D0-S2C			650 (25.6)	300 (11.8)	
MPMA-ABDE4A0E2-S2C			770 (30.3)	420 (16.5)	
MPMA-ABDG8A0B8-S2C	1121 (44.1)	680 (26.8)	530 (20.9)	180 (7.1)	18
MPMA-ABDG8A0D0-S2C			650 (25.6)	300 (11.8)	
MPMA-ABDG8A0E2-S2C			770 (30.3)	420 (16.5)	
MPMA-ABDIOA0B8-S2C	1241 (48.9)	800 (31.5)	530 (20.9)	180 (7.1)	20
MPMA-ABDIOA0D0-S2C			650 (25.6)	300 (11.8)	
MPMA-ABDIOA0E2-S2C			770 (30.3)	420 (16.5)	
MPMA-ABDJ2A0D0-S2C	1361 (53.6)	920 (36.2)	650 (25.6)	300 (11.8)	22
MPMA-ABDJ2A0E2-S2C			770 (30.3)	420 (16.5)	
MPMA-ABDJ2A0F4-S2C			890 (35.0)	540 (21.3)	
MPMA-BBDD2A0B8-S2C	761 (30.0)	320 (12.6)	530 (20.9)	180 (7.1)	12
MPMA-BBDD2A0D0-S2C			650 (25.6)	300 (11.8)	
MPMA-BBDE4A0B8-S2C	881 (34.7)	440 (17.3)	530 (20.9)	180 (7.1)	14
MPMA-BBDE4A0D0-S2C			650 (25.6)	300 (11.8)	
MPMA-BBDE4A0E2-S2C			770 (30.3)	420 (16.5)	
MPMA-BBDG8A0B8-S2C	1121 (44.1)	680 (26.8)	530 (20.9)	180 (7.1)	18
MPMA-BBDG8A0D0-S2C			650 (25.6)	300 (11.8)	
MPMA-BBDG8A0E2-S2C			770 (30.3)	420 (16.5)	
MPMA-BBDIOA0B8-S2C	1241 (48.9)	800 (31.5)	530 (20.9)	180 (7.1)	20
MPMA-BBDIOA0D0-S2C			650 (25.6)	300 (11.8)	
MPMA-BBDIOA0E2-S2C			770 (30.3)	420 (16.5)	
MPMA-BBDJ2A0D0-S2C	1361 (53.6)	920 (36.2)	650 (25.6)	300 (11.8)	22
MPMA-BBDJ2A0E2-S2C			770 (30.3)	420 (16.5)	
MPMA-BBDJ2A0F4-S2C			890 (35.0)	540 (21.3)	

Actuators are designed to metric dimensions. Inch dimensions are approximate conversions from millimeters. Dimensions without tolerances are for reference.

Kinetix VPAR and Kinetix MPAR Electric Cylinders

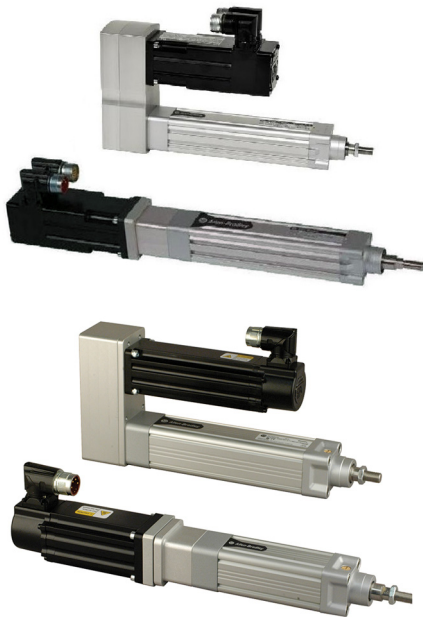

With Kinetix VPAR and MPAR electric cylinders, your applications experience flexible servo-control, ideal for solutions requiring forces to be built up quickly and positions that need to be approached accurately. Available in three ISO 15552 pneumatic-class frame sizes (32, 40, and 63), these durable, quiet, and energy-efficient non-rotating stainless-steel piston rod actuators are an excellent upgrade for pneumatic systems.

With the ability to synchronize and coordinate with multi-axis machine motions, the Kinetix VPAR and MPAR cylinders provide a dynamic, precise response for a wide range of linear motion applications. When seamlessly integrated into the Rockwell Automation® Integrated Architecture™, Kinetix VPAR and MPAR electric cylinders use the Studio 5000 Logix Designer application to extend and retract with precise positioning, velocity, or force. In Force mode, an electric cylinder continues to push the load in a manner similar to an air cylinder, but with the convenience of a limit established by using state-of-the-art software.

Kinetix VPAR and MPAR Electric Cylinder Features

- Fully assembled and ready to mount cylinders contribute to reductions in mechanical design engineering, assembly, wiring, and commissioning time.
- State-of-the-art design features ballscrew construction with linear stroke lengths up to 800 mm (32 in.), absolute high-resolution feedback, and speeds up to 1.0 m/s (39.4 in/s).
- Operates without externally mounted limit or home switches and retains position during power loss for faster machine restart.
- Rated for 100% duty cycle and designed for repeatable, reproducible performance over the actuator's operating life.
- Linear feed force of up to 2500 N (562 lb).
- Positioning repeatability of ± 0.02 mm (0.0008 in.).
- No piping, valving, air, or oil supply required.
- Sizing and engineering with compatible servo drives is made easy with Motion Analyzer and online CAD files.
- Commissioning is simplified by the use of standard Allen-Bradley motor power and feedback cables.
- Full set-up and programming support by using Allen-Bradley Logix 5000™ controllers. Studio 5000 Logix Designer and Ultraware software make setup and commissioning fast and easy.
- Optional 24V DC holding brakes.

Catalog Numbers - Kinetix VPAR and MPAR Electric Cylinders

Catalog numbers consist of various characters, each of which identifies a specific option for that component. Use the catalog numbering table chart below to understand the configuration of your actuator. For questions regarding product availability, contact your Allen-Bradley distributor.

Kinetix VPAR and MPAR Electric Cylinders

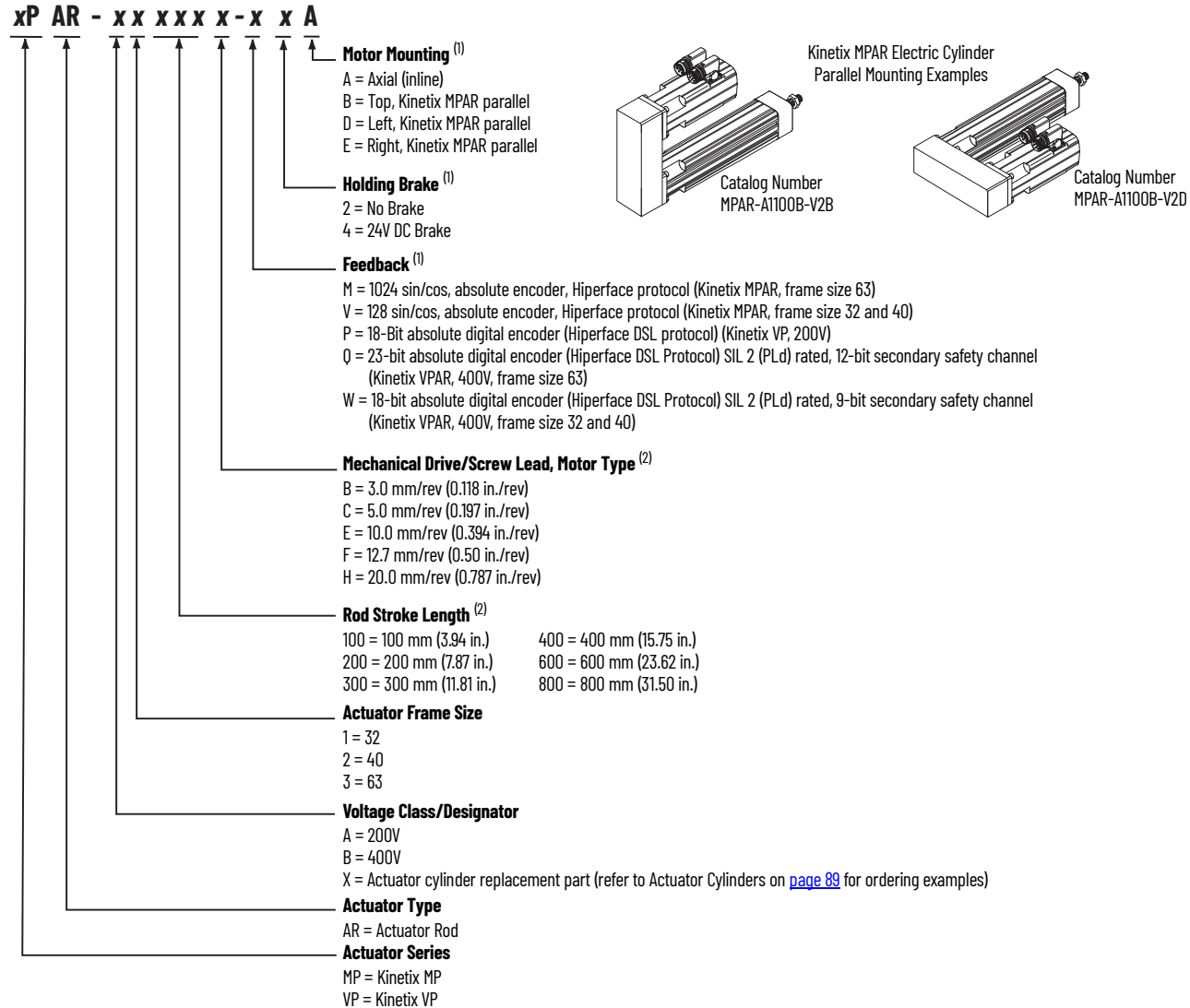

(1) This field does not apply to actuator cylinder replacement parts.
 (2) Not all combinations are available. Only the configurations as listed in Kinetix VPAR and MPAR Electric Cylinders Performance Specifications on [page 87](#) are available.

Kinetix VPAR and MPAR Electric Cylinder Accessories

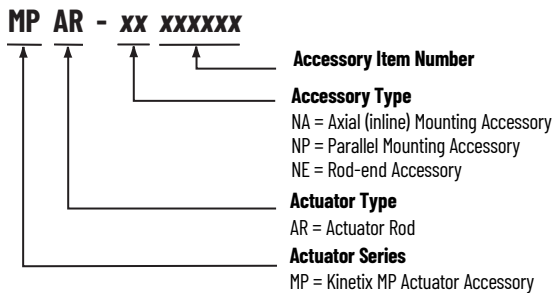

Motor Connector/Cable Compatibility

Kinetix VPAR electric cylinders are equipped with a single SpeedTec DIN connector.

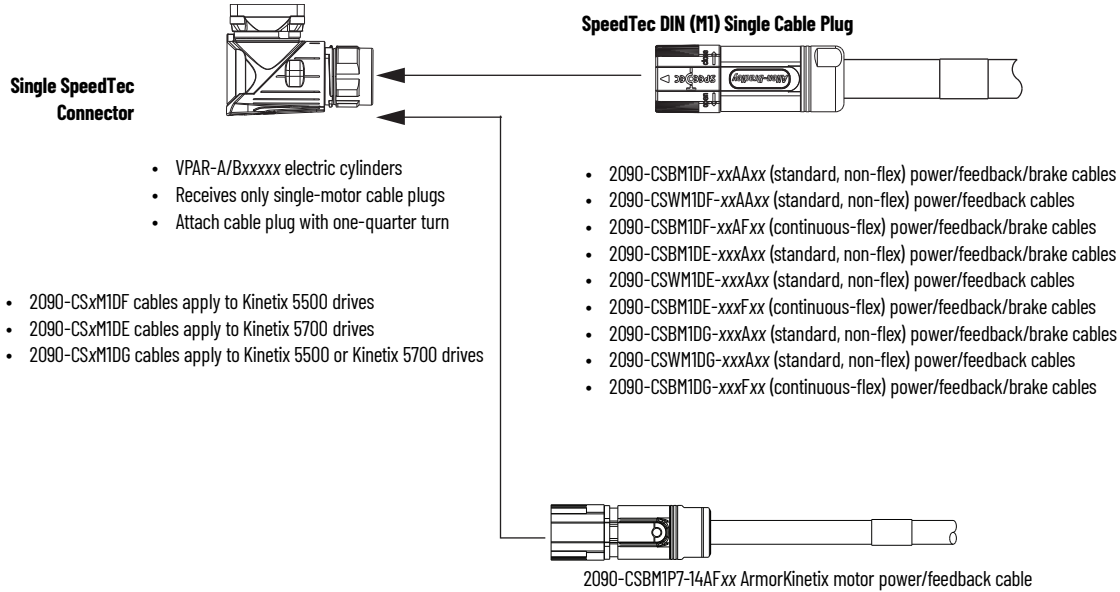

Kinetix MPAR electric cylinders are equipped with SpeedTec DIN connectors.

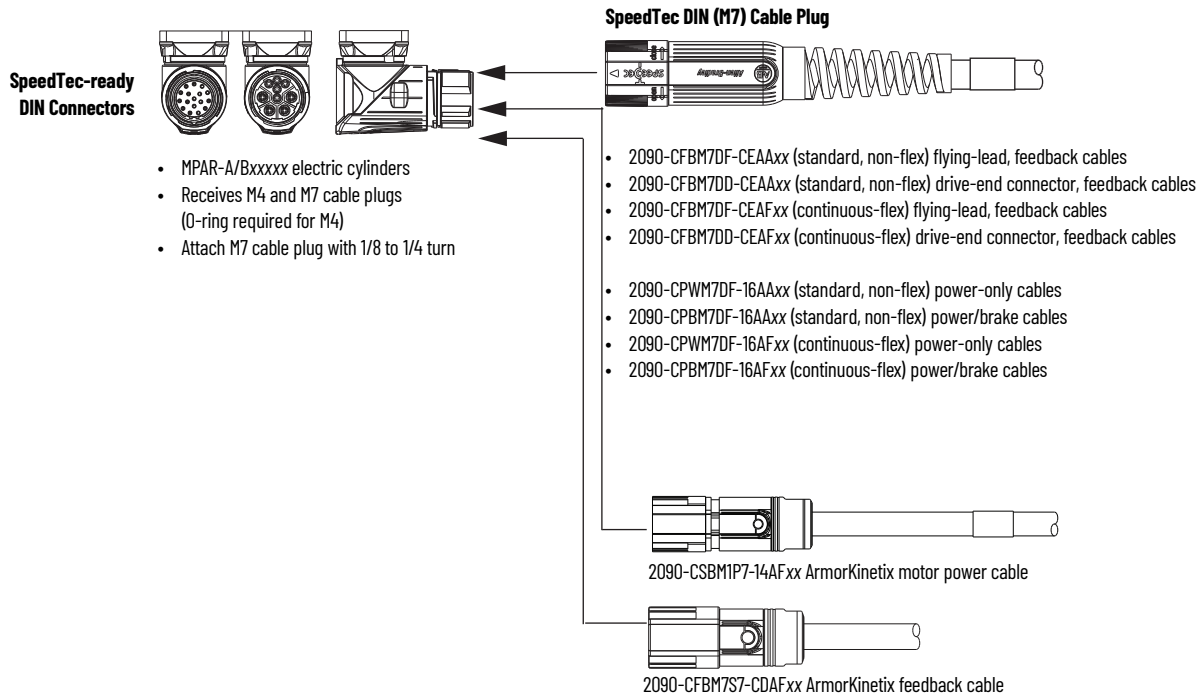

For Kinetix 2090 single motor cable specifications, see Kinetix Motion Accessories Specifications Technical Data, publication [KNX-TD004](#).

Kinetix VPAR and MPAR Electric Cylinder Accessories

These accessory items apply to Kinetix VPAR and MPAR electric cylinders.

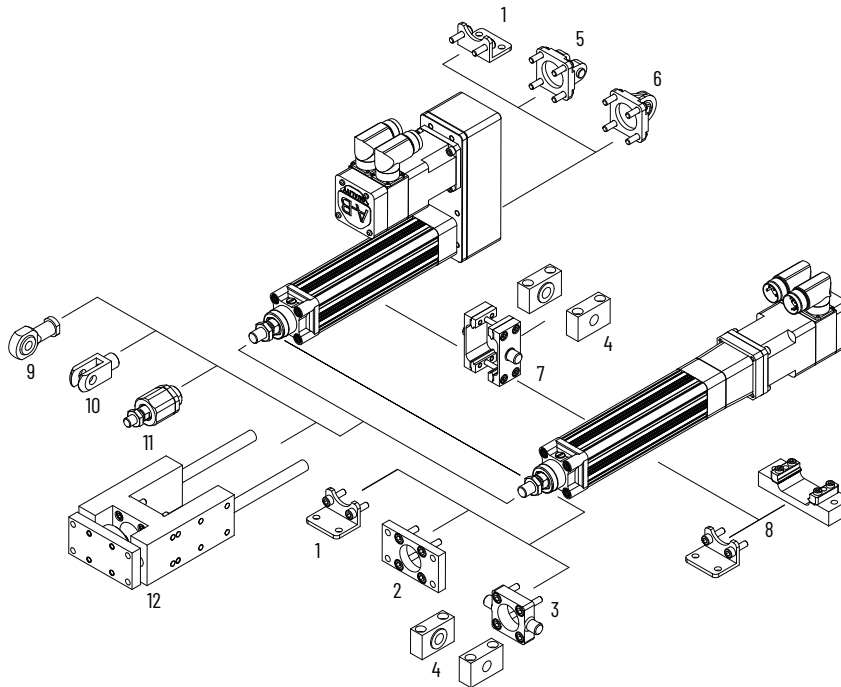

Mounting Attachments

Accessory Item	Description	Cat. No.	Dimensions
1	Foot mount	MPAR-NP62264x	page 105
2	Front flange mounting	MPAR-NA17437x	page 105
3	Trunnion flange	MPAR-NA62262x	page 106
4	Trunnion supports	MPAR-NA6226xx	page 106
5	Swivel flange (pin, narrow)	MPAR-NP17438x	page 107
6	Swivel flange (spherical bearing)	MPAR-NP62263x	page 107
7	Trunnion mount	MPAR-NA16352x	page 108
8	Foot mounting kit	MPAR-NA62268x	page 108

Rod-end Attachments

Accessory Item	Description	Cat. No.	Dimensions
9	Rod eye	MPAR-NE62263x	page 109
10	Rod clevis (threaded hole)	MPAR-NE62263x	page 109
11	Self-aligning rod coupler	MPAR-NE614x	page 110
12	Rod guide	MPAR-NExxxx	page 113

Kinetix VPAR and MPAR Electric Cylinders Rod Load Ratings

Electric cylinders must have the weight of the load supported and guided separately so that only axial force (no radial load) is required of the piston rod throughout the complete extend and retract motion. If some residual radial and/or torsional loading remains unavoidable, a rod guide can be added. Refer to Motion Analyzer for assistance when making these calculations and to determine when a rod guide is needed.

Maximum Permissible Lateral Forces $F_{y\max}$ and $F_{z\max}$ on the Piston Rod

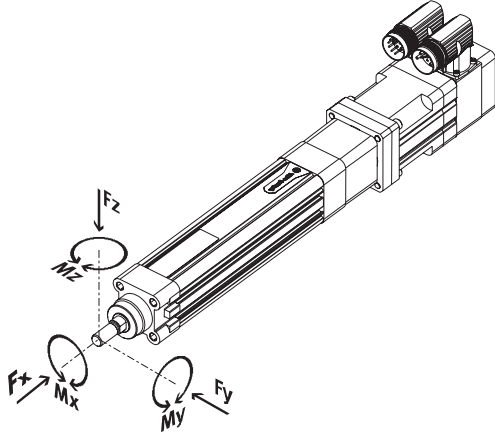

If there are two or more forces and torques acting simultaneously on the piston rod, the following equations must be true:

$$\frac{[F_y]}{F_{y\max}} + \frac{[F_z]}{F_{z\max}} + \frac{[M_y]}{M_{y\max}} + \frac{[M_z]}{M_{z\max}} \leq 1$$

$$[F_x] \leq F_{x\max}$$

$$[M_x] \leq M_{x\max}$$

Horizontal Mounting Position

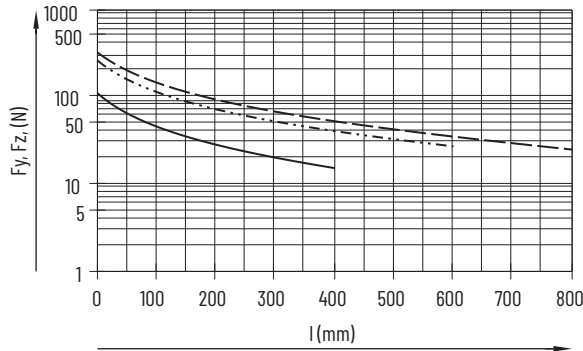

Vertical Mounting Position

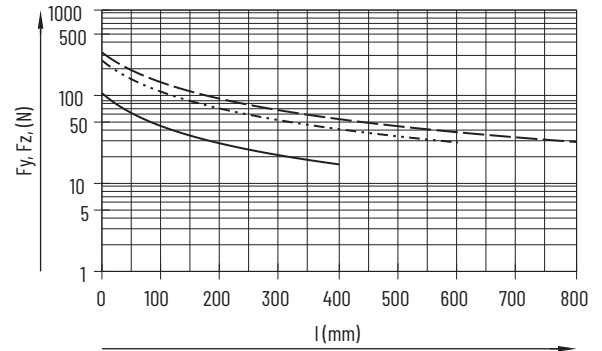

— Frame 32
 - - - Frame 40
 - · - Frame 63

Load Force Ratings

Attribute	Frame 32	Frame 40	Frame 63
F_x max (static)	600 N (135 lb)	1400 N (315 lb)	3700 N (832 lb)
M_x max	1 N·m (8.8 lb·in)	1 N·m (8.8 lb·in)	1.5 N·m (13.3 lb·in)
M_y max, M_z max	8 N·m (70.7 lb·in)	20 N·m (177 lb·in)	27 N·m (239 lb·in)

Kinetix VPAR and MPAR Electric Cylinders Piston Rod Deflection Specifications

These specifications are for determining the amount of shaft deflection to expect from a given load.

Piston-rod deflection specifications are a function of stroke length.

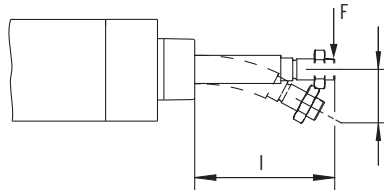

Kinetix VPAR and MPAR Electric Cylinders (Frame 32)

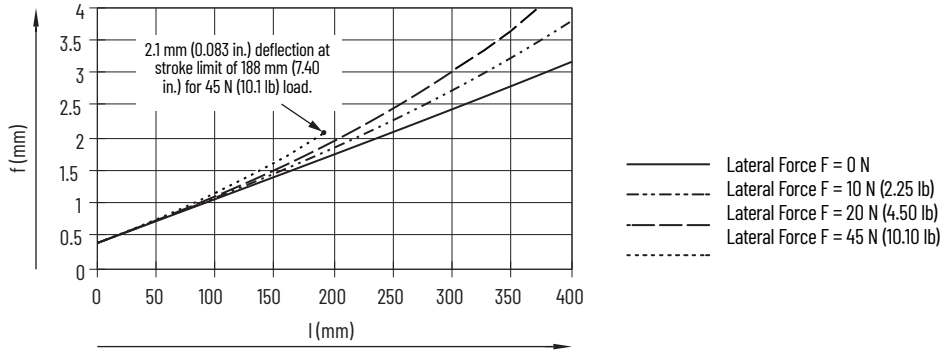

Kinetix VPAR and MPAR Electric Cylinders (Frame 40)

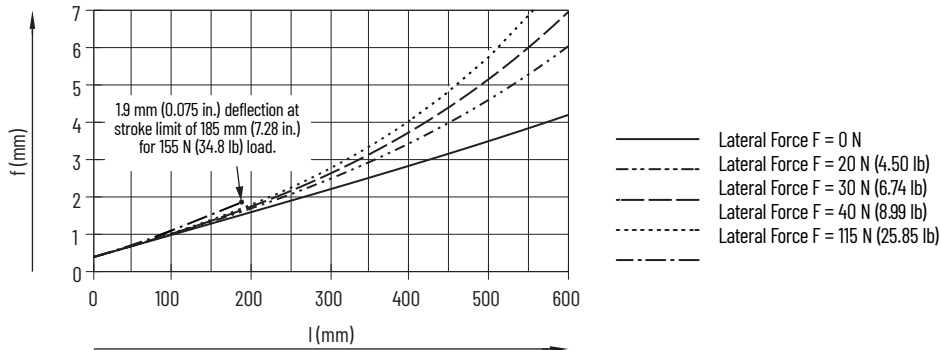

Kinetix VPAR and MPAR Electric Cylinders (Frame 63)

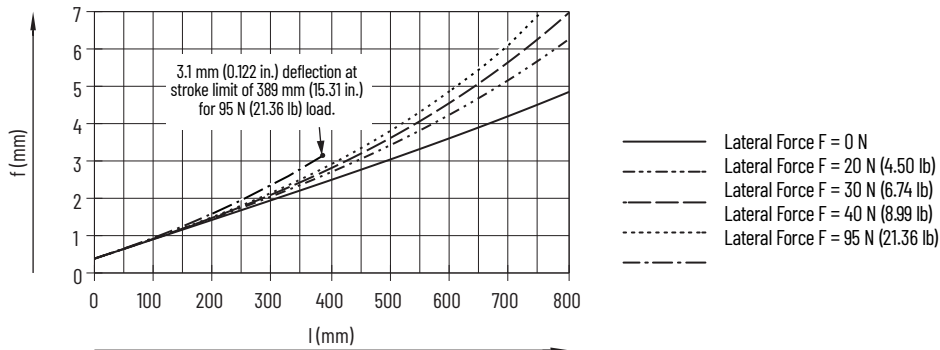

Kinetix VPAR and MPAR Electric Cylinders Life Specifications

Electric cylinder life specifications (running performance) are based on a combination of tested and calculated data. If the parameters of your application are different, your results can be different. The achievable running performance, expressed as L (km), is a function of mean feed force F, according to DIN 69051-4 as shown below and illustrated on [page 85](#). Refer to Motion Analyzer software for assistance when making these calculations and determining the running performance for your application.

Calculation of the Feed Force Fx

The peak feed force value must not exceed the maximum feed force within a movement cycle. In the case of vertical operation, the peak value is generally achieved during the acceleration phase of the upwards stroke. If the maximum feed force is exceeded, you can increase wear and shorten the service life of the ballscrew. The maximum speed must likewise not be exceeded.

$$F_x \leq F_{x \max}$$

and

$$V_x \leq V_{x \max}$$

During operation, the continuous feed force can be briefly exceeded up to the maximum feed force. The continuous feed force must, however, be adhered to when averaged over a movement cycle.

$$F_{x \text{m}} \leq F_{x \text{cont}}$$

Mean Feed Speed (to DIN 69051-4)

$$v_{xm} = \sum |v_x| \times \frac{q}{100} + |v_{x1}| \times \frac{q1}{100} + |v_{x2}| \times \frac{q2}{100} + |v_{x3}| \times \frac{q3}{100} + \dots$$

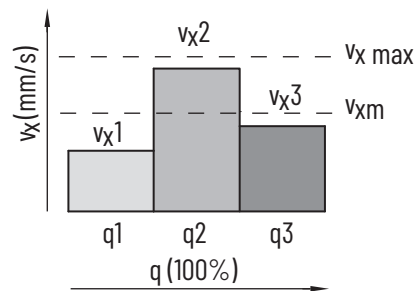

Mean Feed Force (to DIN 69051-4)

$$F_{xm} = \sqrt[3]{\sum |F_x|^3 \times \frac{|v_x|}{|v_{xm}|} \times \frac{q}{100}} =$$

$$F_{xm} = \sqrt[3]{|F_{x1}|^3 \times \frac{|v_{x1}|}{|v_{xm}|} \times \frac{q1}{100} + |F_{x2}|^3 \times \frac{|v_{x2}|}{|v_{xm}|} \times \frac{q2}{100} + |F_{x3}|^3 \times \frac{|v_{x3}|}{|v_{xm}|} \times \frac{q3}{100} + \dots}$$

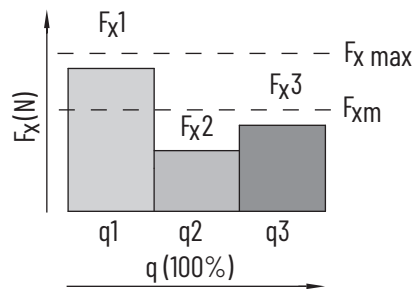

- | | | | |
|---------------------|-------------------------|--------------|----------------------|
| F_x | = Feed Force | V_x | = Feed Speed |
| F_{xm} | = Mean Feed Force | V_{xm} | = Mean Feed Speed |
| $F_{x \max}$ | = Maximum Feed Force | $V_{x \max}$ | = Maximum Feed Speed |
| $F_{x \text{cont}}$ | = Continuous Feed Force | | |
| q | = % of Time | | |

The achievable running performance, L (km), is a function of mean feed force F, according to DIN 69051-4 as illustrated in the figures below.

Kinetix VPAR and MPAR Electric Cylinders (Frame 32)

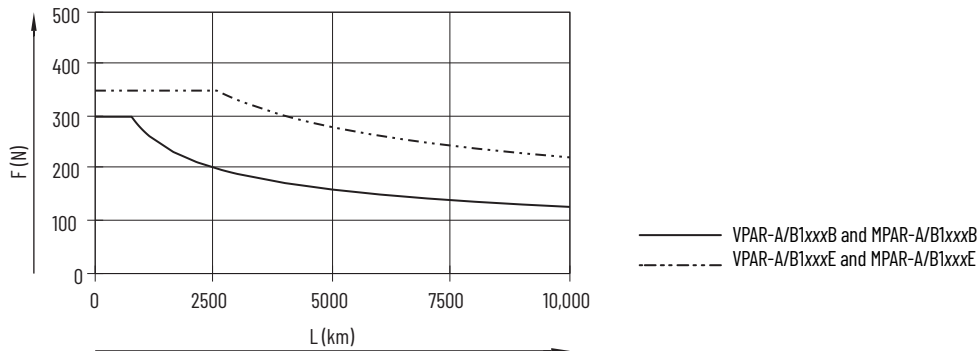

Kinetix VPAR and MPAR Electric Cylinders (Frame 40)

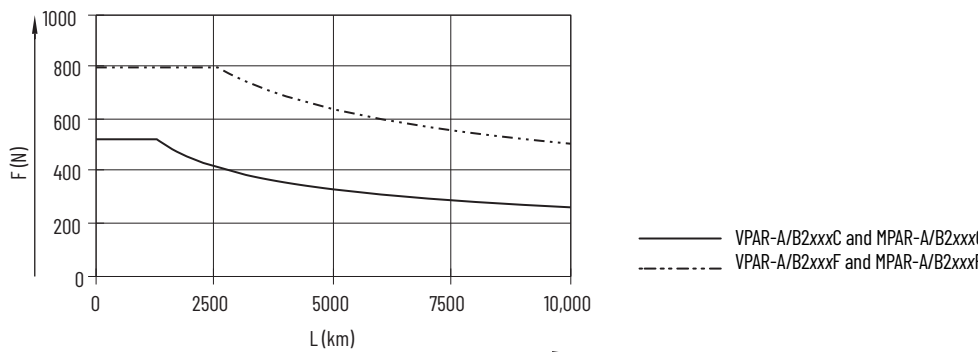

Kinetix VPAR and MPAR Electric Cylinders (Frame 63)

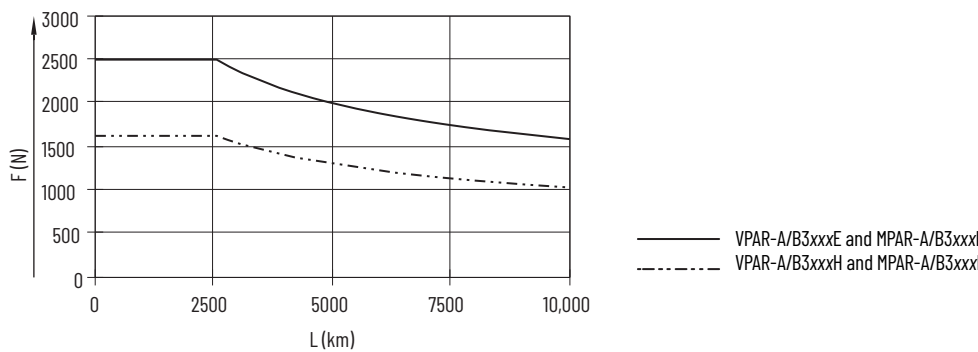

Technical Specifications - Kinetix VPAR and MPAR Electric Cylinders

Kinetix VPAR and MPAR Electric Cylinders General Specifications

Attribute	Frame 32	Frame 40	Frame 63
Construction design	Ballscrew servo-driven non-rotating piston rod ⁽¹⁾		
Piston rod thread	M10x1.25	M12x1.25	M16x1.50
Working stroke	100 mm (3.94 in.) 200 mm (7.87 in.) 300 mm (11.81 in.) 400 mm (15.75 in.)	100 mm (3.94 in.) 200 mm (7.87 in.) 300 mm (11.81 in.) 400 mm (15.75 in.) 600 mm (23.62 in.)	100 mm (3.94 in.) 200 mm (7.87 in.) 300 mm (11.81 in.) 400 mm (15.75 in.) 600 mm (23.62 in.) 800 mm (31.50 in.)
Protection against torsion/guide	Plain bearing guide		
Stroke reserve	0 mm		
Angle of rotation at the piston rod, max	±0.30°	±0.25°	±0.20°
Impact energy (E) at the end positions $E=0.5 \times m \times v^2$	0.0001 J	0.0002 J	0.0004 J
Positioning repeatability, max	±0.02 mm (0.0008 in.)		
Reversing backlash, max ⁽²⁾	0.05 mm (0.002 in.)		
Duty cycle	100%		
Position sensing (feedback)	Multi-turn absolute encoder		
Type of mounting	Via female threads		
	Via accessories		
Mounting position	Any		

(1) The maximum rotational force (Mx) applied in the application is limited as specified in Load Force Ratings on [page 82](#).

(2) In new condition.

Kinetix VPAR and MPAR Electric Cylinders Motor Brake Specifications

Electric Cylinder Cat. No.	Holding Force N (lb)	Coil Current at 24V DC A	Brake Response Time		
			Release ms	Engage (by using external arc suppression device)	
				MOV ms	Diode ms
VPAR-A/B1xxxB	700 (157)	0.30...0.36	38	-	25
VPAR-A/B1xxxE	700 (157)				
VPAR-A/B2xxxC	2000 (449)				
VPAR-A/B2xxxF	1600 (359)	0.57...0.69	66	-	42
VPAR-A/B3xxxE	2900 (652)	0.45...0.55	90	-	65
VPAR-A/B3xxxH	2200 (494)	0.62...0.76	90	-	95
MPAR-A/B1xxxB	300 (67)	0.43...0.53	23	9	18
MPAR-A/B1xxxE	350 (79)				
MPAR-A/B2xxxC	525 (118)				
MPAR-A/B2xxxF	800 (180)	0.46...0.56	58	20	42
MPAR-A/B3xxxE	2364 (531)	0.45...0.55	50	20	110
MPAR-A/B3xxxH	1625 (365)	0.58...0.70	110	25	160

Kinetix VPAR and MPAR Electric Cylinders Performance Specifications

Electric Cylinder ⁽¹⁾ Cat. No.	Frame	Peak Feed Force N (lb)	Continuous Stall Force N (lb)	Speed, max m/s (in/s)	Stroke Lengths mm (in.)	Acceleration, max m/s ² (in/s ²)
VPAR-A1xxxB-Pxx VPAR-B1xxxB-Wxx MPAR-A1xxxB-Vxx MPAR-B1xxxB-Vxx	32	300 (67)	240 (54)	0.15 (5.9)	100 (3.94) 200 (7.87) 300 (11.81) 400 (15.75)	6.0 (236)
VPAR-A1xxxE-Pxx VPAR-B1xxxE-Wxx MPAR-A1xxxE-Vxx MPAR-B1xxxE-Vxx		350 (79)	280 (63)	0.50 (19.7)		
VPAR-A2xxxC-Pxx VPAR-B2xxxC-Wxx MPAR-A2xxxC-Vxx MPAR-B2xxxC-Vxx	40	525 (118)	420 (94)	0.25 (9.8)	100 (3.94) 200 (7.87) 300 (11.81) 400 (15.75) 600 (23.62)	
VPAR-A2xxxF-Pxx VPAR-B2xxxF-Wxx MPAR-A2xxxF-Vxx MPAR-B2xxxF-Vxx		800 (180)	640 (144)	0.64 (25.2)		
VPAR-A3xxxE-Pxx VPAR-B3xxxE-Qxx MPAR-A3xxxE-Mxx MPAR-B3xxxE-Mxx	63	2500 (562)	2000 (450)	0.50 (19.7)	100 (3.94) 200 (7.87) 300 (11.81) 400 (15.75) 600 (23.62) 800 (31.50)	
VPAR-A3xxxH-Pxx VPAR-B3xxxH-Qxx MPAR-A3xxxH-Mxx MPAR-B3xxxH-Mxx		1625 (365)	1300 (292)	1.0 (39.4)		

(1) Stroke length replaces xxx in each catalog number.

Kinetix VPAR and MPAR Electric Cylinders Moving Load Specifications

Attribute	VPAR-x1xxxB MPAR-x1xxxB	VPAR-x1xxxE MPAR-x1xxxE	VPAR-x2xxxC MPAR-x2xxxC	VPAR-x2xxxF MPAR-x2xxxF	VPAR-x3xxxE MPAR-x3xxxE	VPAR-x3xxxH MPAR-x3xxxH
	Frame 32, Weight, approx g (oz)		Frame 40, Weight, approx g (oz)		Frame 63, Weight, approx g (oz)	
Moving load with 0 mm stroke	170 (6.0)	200 (7.05)	310 (10.93)	380 (13.40)	810 (28.57)	810 (1.79)
Moving load per 10 mm stroke	6.9 (0.24)	6.9 (0.24)	8.9 (0.31)	8.9 (0.31)	12.8 (0.45)	12.8 (0.028)

Weight Specifications

Kinetix VPAR Electric Cylinders (weight of cylinder with non-brake motor)

Electric Cylinder Cat. No.	Weight, Approx kg (lb)	Electric Cylinder Cat. No.	Weight, Approx kg (lb)	Electric Cylinder Cat. No.	Weight, Approx kg (lb)
VPAR-x1100B-P2A	2.8 (6.07) ⁽¹⁾	VPAR-x2100C-P2A	3.8 (8.32) ⁽¹⁾	VPAR-x3100E-x2A	9.4 (20.57) ⁽²⁾
VPAR-x1100B-P2B/D/E	3.7 (8.05) ⁽¹⁾	VPAR-x2100C-P2B/D/E	4.5 (9.86) ⁽¹⁾	VPAR-x3100E-x2B/D/E	13.5 (29.59) ⁽²⁾
VPAR-x1200B-P2A	3.1 (6.73) ⁽¹⁾	VPAR-x2200C-P2A	4.2 (9.20) ⁽¹⁾	VPAR-x3200E-x2A	10.2 (22.33) ⁽²⁾
VPAR-x1200B-P2B/D/E	4.0 (8.71) ⁽¹⁾	VPAR-x2200C-P2B/D/E	5.0 (10.96) ⁽¹⁾	VPAR-x3200E-x2B/D/E	14.3 (31.35) ⁽²⁾
VPAR-x1300B-P2A	3.4 (7.39) ⁽¹⁾	VPAR-x2300C-P2A	4.7 (10.30) ⁽¹⁾	VPAR-x3300E-x2A	11.0 (24.09) ⁽²⁾
VPAR-x1300B-P2B/D/E	4.3 (9.37) ⁽¹⁾	VPAR-x2300C-P2B/D/E	5.4 (11.84) ⁽¹⁾	VPAR-x3300E-x2B/D/E	15.1 (33.11) ⁽²⁾
VPAR-x1400B-P2A	3.7 (8.05) ⁽¹⁾	VPAR-x2400C-P2A	5.1 (11.18) ⁽¹⁾	VPAR-x3400E-x2A	11.8 (25.85) ⁽²⁾
VPAR-x1400B-P2B/D/E	4.7 (10.25) ⁽¹⁾	VPAR-x2400C-P2B/D/E	5.9 (12.94) ⁽¹⁾	VPAR-x3400E-x2B/D/E	16.0 (35.09) ⁽²⁾
VPAR-x1100E-P2A	3.1 (6.78) ⁽¹⁾	VPAR-x2600C-P2A	6.1 (13.38) ⁽¹⁾	VPAR-x3600E-x2A	13.4 (29.37) ⁽²⁾
VPAR-x1100E-P2B/D/E	3.9 (8.54) ⁽¹⁾	VPAR-x2600C-P2B/D/E	6.8 (14.92) ⁽¹⁾	VPAR-x3600E-x2B/D/E	17.6 (38.61) ⁽²⁾
VPAR-x1200E-P2A	3.4 (7.44) ⁽¹⁾	VPAR-x2100F-P2A	4.2 (9.24) ⁽³⁾	VPAR-x3800E-x2A	15.1 (33.11) ⁽²⁾
VPAR-x1200E-P2B/D/E	4.2 (9.20) ⁽¹⁾	VPAR-x2100F-P2B/D/E	6.5 (14.30) ⁽³⁾	VPAR-x3800E-x2B/D/E	19.4 (42.77) ⁽²⁾
VPAR-x1300E-P2A	3.7 (8.10) ⁽¹⁾	VPAR-x2200F-P2A	4.7 (10.34) ⁽³⁾	VPAR-x3100H-x2A	9.2 (20.28) ⁽⁴⁾
VPAR-x1300E-P2B/D/E	4.6 (10.08) ⁽¹⁾	VPAR-x2200F-P2B/D/E	7.0 (15.40) ⁽³⁾	VPAR-x3100H-x2B/D/E	13.3 (29.32) ⁽⁴⁾
VPAR-x1400E-P2A	4.1 (8.98) ⁽¹⁾	VPAR-x2300F-P2A	5.2 (11.44) ⁽³⁾	VPAR-x3200H-x2A	10.2 (22.48) ⁽⁴⁾
VPAR-x1400E-P2B/D/E	4.9 (10.74) ⁽¹⁾	VPAR-x2300F-P2B/D/E	7.5 (16.50) ⁽³⁾	VPAR-x3200H-x2B/D/E	14.1(32.85) ⁽⁴⁾
		VPAR-x2400F-P2A	5.6 (12.32) ⁽³⁾	VPAR-x3300H-x2A	11.0 (24.25) ⁽⁴⁾
		VPAR-x2400F-P2B/D/E	7.9 (17.38) ⁽³⁾	VPAR-x3300H-x2B/D/E	14.9 (32.85) ⁽⁴⁾
		VPAR-x2600F-P2A	6.6 (14.52) ⁽³⁾	VPAR-x3400H-x2A	11.8 (26.01) ⁽⁴⁾
		VPAR-x2600F-P2B/D/E	8.9 (19.58) ⁽³⁾	VPAR-x3400H-x2B/D/E	15.8 (34.83) ⁽⁴⁾
				VPAR-x3600H-x2A	13.5 (29.76) ⁽⁴⁾
				VPAR-x3600H-x2B/D/E	17.4 (38.36) ⁽⁴⁾
				VPAR-x3800H-x2A	15.1 (33.29) ⁽⁴⁾
				VPAR-x3800H-x2B/D/E	19.0 (41.89) ⁽⁴⁾

- (1) If you are ordering a VPAR-x1xxxB-P4x or VPAR-x2xxxC-P4x electric cylinder with brake, add 0.34 kg (0.75 lb).
- (2) If you are ordering a VPAR-x3xxxE-P4x electric cylinder with brake, add 0.63 kg (1.39 lb).
- (3) If you are ordering a VPAR-x2xxxF-P4x electric cylinder with brake, add 0.59 kg (1.30 lb).
- (4) If you are ordering a VPAR-x3xxxH-P4x electric cylinder with brake, add 0.87 kg (1.92 lb).

Kinetix MPAR Electric Cylinders (weight of cylinder with non-brake motor)

Electric Cylinder Cat. No.	Weight, (1) approx kg (lb)	Electric Cylinder Cat. No.	Weight, approx kg (lb)	Electric Cylinder Cat. No.	Weight, approx kg (lb)
MPAR-x1100B-V2A	2.6 (5.73)	MPAR-x2100C-V2A	3.7 (8.16) ⁽¹⁾	MPAR-x3100E-M2A	9.5 (20.94) ⁽²⁾
MPAR-x1100B-V2B/D/E	3.5 (7.72)	MPAR-x2100C-V2B/D/E	4.4 (9.70) ⁽¹⁾	MPAR-x3100E-M2B/D/E	13.6 (29.98) ⁽²⁾
MPAR-x1200B-V2A	2.9 (6.39)	MPAR-x2200C-V2A	4.1 (9.04) ⁽¹⁾	MPAR-x3200E-M2A	10.3 (22.71) ⁽²⁾
MPAR-x1200B-V2B/D/E	3.8 (8.377)	MPAR-x2200C-V2B/D/E	4.9 (10.80) ⁽¹⁾	MPAR-x3200E-M2B/D/E	14.4 (31.75) ⁽²⁾
MPAR-x1300B-V2A	3.2 (7.05)	MPAR-x2300C-V2A	4.6 (10.14) ⁽¹⁾	MPAR-x3300E-M2A	11.1 (24.47) ⁽²⁾
MPAR-x1300B-V2B/D/E	4.1 (9.04)	MPAR-x2300C-V2B/D/E	5.3 (11.68) ⁽¹⁾	MPAR-x3300E-M2B/D/E	15.2 (33.51) ⁽²⁾
MPAR-x1400B-V2A	3.5 (7.72)	MPAR-x2400C-V2A	5.0 (11.02) ⁽¹⁾	MPAR-x3400E-M2A	11.9 (26.23) ⁽²⁾
MPAR-x1400B-V2B/D/E	4.5 (9.92)	MPAR-x2400C-V2B/D/E	5.8 (12.79) ⁽¹⁾	MPAR-x3400E-M2B/D/E	16.1 (35.49) ⁽²⁾
MPAR-x1100E-V2A	3.0 (6.61)	MPAR-x2600C-V2A	6.0 (11.02) ⁽¹⁾	MPAR-x3600E-M2A	13.5 (29.76) ⁽²⁾
MPAR-x1100E-V2B/D/E	3.8 (8.377)	MPAR-x2600C-V2B/D/E	6.7 (14.77) ⁽¹⁾	MPAR-x3600E-M2B/D/E	17.7 (39.02) ⁽²⁾
MPAR-x1200E-V2A	3.3 (7.27)	MPAR-x2100F-V2A	4.2 (9.26) ⁽³⁾	MPAR-x3800E-M2A	15.2 (33.51) ⁽²⁾

Kinetix MPAR Electric Cylinders (weight of cylinder with non-brake motor) (continued)

Electric Cylinder Cat. No.	Weight, ⁽¹⁾ approx kg (lb)
MPAR-x1200E-V2B/D/E	4.1 (9.04)
MPAR-x1300E-V2A	3.6 (7.94)
MPAR-x1300E-V2B/D/E	4.5 (9.92)
MPAR-x1400E-V2A	4.0 (8.82)
MPAR-x1400E-V2B/D/E	4.8 (10.58)

Electric Cylinder Cat. No.	Weight, approx kg (lb)
MPAR-x2100F-V2B/D/E	6.5 (14.33) ⁽³⁾
MPAR-x2200F-V2A	4.7 (10.36) ⁽³⁾
MPAR-x2200F-V2B/D/E	7.0 (15.43) ⁽³⁾
MPAR-x2300F-V2A	5.2 (11.46) ⁽³⁾
MPAR-x2300F-V2B/D/E	7.5 (16.53) ⁽³⁾
MPAR-x2400F-V2A	5.6 (12.34) ⁽³⁾
MPAR-x2400F-V2B/D/E	7.9 (17.42) ⁽³⁾
MPAR-x2600F-V2A	6.6 (14.55) ⁽³⁾
MPAR-x2600F-V2B/D/E	8.9 (19.62) ⁽³⁾

Electric Cylinder Cat. No.	Weight, approx kg (lb)
MPAR-x3800E-M2B/D/E	19.3 (42.55) ⁽²⁾
MPAR-x3100H-M2A	9.3 (20.50) ⁽⁴⁾
MPAR-x3100H-M2B/D/E	13.2 (29.10) ⁽⁴⁾
MPAR-x3200H-M2A	10.1 (22.27) ⁽⁴⁾
MPAR-x3200H-M2B/D/E	14.0 (30.86) ⁽⁴⁾
MPAR-x3300H-M2A	10.9 (24.03) ⁽⁴⁾
MPAR-x3300H-M2B/D/E	14.8 (32.63) ⁽⁴⁾
MPAR-x3400H-M2A	11.7 (25.79) ⁽⁴⁾
MPAR-x3400H-M2B/D/E	15.7 (34.61) ⁽⁴⁾
MPAR-x3600H-M2A	13.4 (29.54) ⁽⁴⁾
MPAR-x3600H-M2B/D/E	17.3 (38.14) ⁽⁴⁾
MPAR-x3800H-M2A	15.0 (33.07) ⁽⁴⁾
MPAR-x3800H-M2B/D/E	18.9 (41.67) ⁽⁴⁾

(1) If ordering MPAR-x1xxx-V4x or MPAR-x2xxxC-V4x electric cylinder with brake, add 0.2 kg (0.4 lb).

(2) If ordering MPAR-x3xxxE-M4x electric cylinder with brake, add 1.0 kg (2.2 lb).

(3) If ordering MPAR-x2xxxF-V4x electric cylinder with brake, add 0.4 kg (0.9 lb).

(4) If ordering MPAR-x3xxxH-M4x electric cylinder with brake, add 1.7 kg (3.7 lb).

Actuator Cylinders (weight of replacement cylinder)

Actuator Cylinder ⁽¹⁾ Cat. No.	Weight, approx kg (lb)
MPAR-X1100B	1.1 (2.43)
MPAR-X1200B	1.4 (3.09)
MPAR-X1300B	1.7 (3.75)
MPAR-X1400B	2.1 (4.63)
MPAR-X1100E	1.1 (2.43)
MPAR-X1200E	1.4 (3.09)
MPAR-X1300E	1.8 (3.97)
MPAR-X1400E	2.1 (4.63)

Actuator Cylinder ⁽¹⁾ Cat. No.	Weight, approx kg (lb)
MPAR-X2100C	1.7 (3.75)
MPAR-X2200C	2.2 (4.85)
MPAR-X2300C	2.6 (5.73)
MPAR-X2400C	3.1 (6.83)
MPAR-X2600C	4.0 (8.82)
MPAR-X2100F	1.8 (3.97)
MPAR-X2200F	2.3 (5.07)
MPAR-X2300F	2.8 (6.17)
MPAR-X2400F	3.2 (7.05)
MPAR-X2600F	4.2 (9.26)

Actuator Cylinder ⁽¹⁾ Cat. No.	Weight, approx kg (lb)
MPAR-X3100E	3.8 (8.38)
MPAR-X3200E	4.6 (10.14)
MPAR-X3300E	5.4 (11.90)
MPAR-X3400E	6.3 (13.89)
MPAR-X3600E	7.9 (17.42)
MPAR-X3800E	9.5 (20.94)
MPAR-X3100H	3.8 (8.38)
MPAR-X3200H	4.6 (10.14)
MPAR-X3300H	5.4 (11.90)
MPAR-X3400H	6.3 (13.89)
MPAR-X3600H	7.9 (17.42)
MPAR-X3800H	9.5 (20.94)

(1) If ordering a replacement cylinder for electric cylinder catalog numbers MPAR-A2100C-V2A, the replacement actuator cylinder catalog number is MPAR-X2100C.

Kinetix VPAR and MPAR Electric Cylinders Mounting Accessories

Accessory Item		Frame	Cat. No.	Weight, approx g (oz)
1	Foot mount attachment	32	MPAR-NP622640	90 (3.17)
		40	MPAR-NP622641	110 (3.53)
		63	MPAR-NP622642	250 (8.82)
2	Flange mounting	32	MPAR-NA174376	240 (8.46)
		40	MPAR-NA174377	280 (9.88)
		63	MPAR-NA174379	690 (24.34)
3	Trunnion flange	32	MPAR-NA622625	190 (6.70)
		40	MPAR-NA622626	450 (15.87)
		63	MPAR-NA622627	1130 (39.86)
4	Trunnion support	32	MPAR-NA622628	280 (9.88)
		40	MPAR-NA622629	460 (16.23)
		63	MPAR-NA622630	620 (21.87)

Accessory Item		Frame	Cat. No.	Weight, approx g (oz)
5	Swivel flange (pin, narrow)	32	MPAR-NP174383	90 (3.17)
		40	MPAR-NP174384	140 (4.94)
		63	MPAR-NP174386	320 (11.29)
6	Swivel flange (spherical bearing)	32	MPAR-NP622637	90 (3.17)
		40	MPAR-NP622638	130 (4.58)
		63	MPAR-NP622639	280 (9.88)
7	Trunnion mount	32	MPAR-NA163525	230 (8.11)
		40	MPAR-NA163526	400 (14.11)
		63	MPAR-NA163528	920 (32.45)
8	Foot mounting kit	32	MPAR-NA622685	240 (8.46)
		40	MPAR-NA622686	310 (10.93)
		63	MPAR-NA622687	510 (17.99)

Kinetix VPAR and MPAR Electric Cylinders Rod-end Accessories

Accessory Item		Frame	Cat. No.	Weight, approx g (oz)
9	Rod eye	32	MPAR-NE622631	100 (3.53)
		40	MPAR-NE622632	150 (5.29)
		63	MPAR-NE622633	300 (10.58)
10	Rod clevis	32	MPAR-NE622634	80 (2.82)
		40	MPAR-NE622635	140 (4.94)
		63	MPAR-NE622636	340 (11.99)
11	Self-aligning rod coupler	32	MPAR-NE6140	210 (7.41)
		40	MPAR-NE6141	220 (7.76)
		63	MPAR-NE6142	650 (22.93)

Kinetix VPAR and MPAR Electric Cylinders Rod Guide (Item 12) Accessories

Rod Guide Cat. No.	Frame	Stroke Length mm (in.)	Weight, approx kg (lb)
MPAR-NE34494	32	100 (3.9)	1.7 (3.75)
MPAR-NE34496		200 (7.9)	1.9 (4.19)
MPAR-NE34497		320 (12.6)	2.1 (4.63)
MPAR-NE150290		400 (15.7)	2.3 (5.07)
MPAR-NE34500	40	100 (3.9)	2.7 (5.95)
MPAR-NE34502		200 (7.9)	3.0 (6.61)
MPAR-NE34504		320 (12.6)	3.4 (7.50)
MPAR-NE150291		400 (15.7)	3.7 (8.16)
MPAR-NE34505		500 (19.7)	4.0 (8.82)
MPAR-NE34514	63	100 (3.9)	5.9 (13.01)
MPAR-NE34516		200 (7.9)	6.4 (14.11)
MPAR-NE34518		320 (12.6)	7.0 (15.43)
MPAR-NE34519		400 (15.7)	7.4 (16.31)
MPAR-NE34520		500 (19.7)	7.9 (17.42)

Dimensions - Kinetix VPAR Electric Cylinders

Kinetix VPAR Electric Cylinders (Frame 32)

Dimensions are in mm (in.).

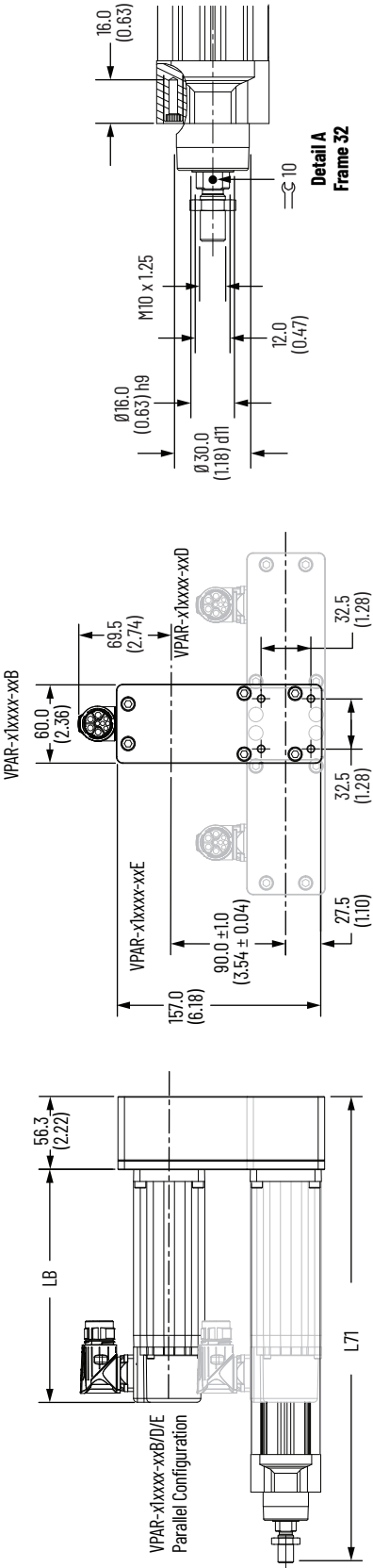
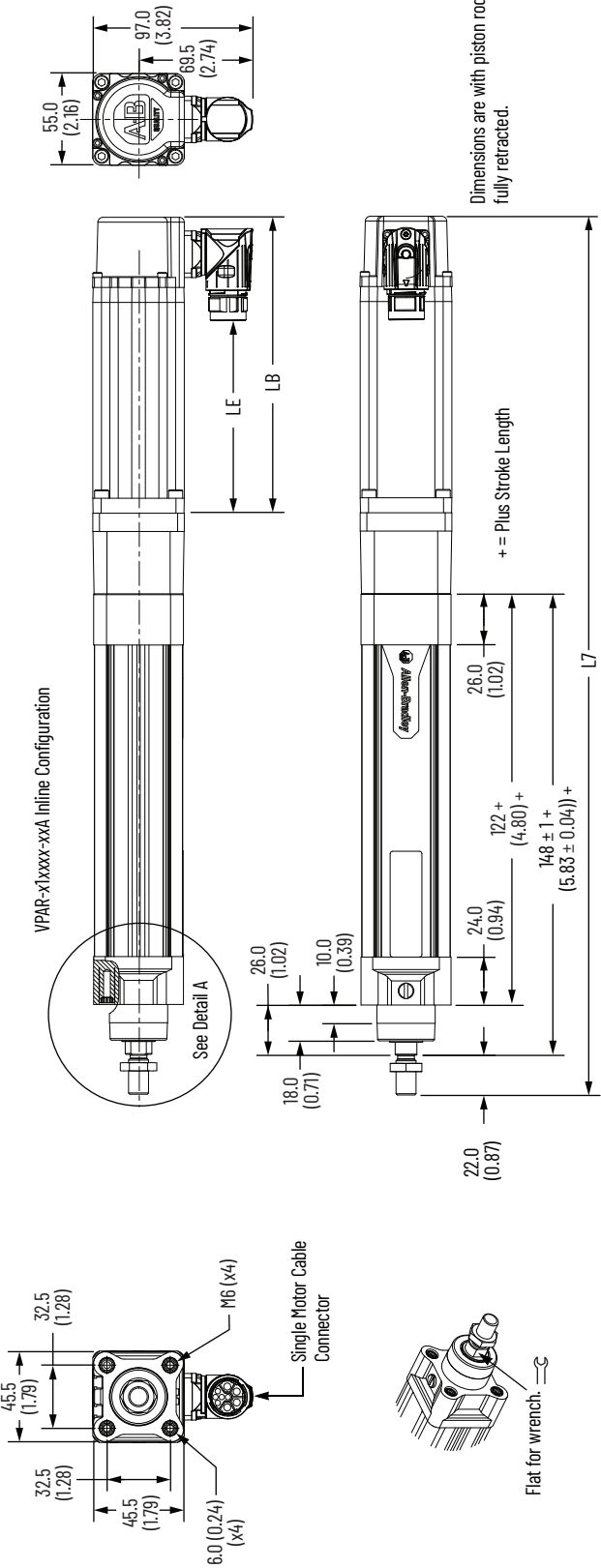

Kinetix VPAR Electric Cylinder Dimensions (inline configuration, Frame 32)

Electric Cylinder Cat. No.	L7 ⁽¹⁾ mm (in.)	LB ⁽¹⁾ mm (in.)	LE ⁽¹⁾ mm (in.)
VPAR-x1100B-P2A	467.3 (18.40)	148.1 (5.83)	85.3 (3.36)
VPAR-x1200B-P2A	567.3 (22.33)		
VPAR-x1300B-P2A	667.3 (26.27)		
VPAR-x1400B-P2A	767.3 (30.21)		
VPAR-x1100E-P2A	492.3 (19.38)	173.1 (6.81)	110.3 (4.34)
VPAR-x1200E-P2A	592.3 (23.32)		
VPAR-x1300E-P2A	692.3 (27.26)		
VPAR-x1400E-P2A	792.3 (31.19)		

(1) If you are ordering an VPAR-x1xxxx-P4x actuator with brake, add 30.6 mm (1.20 in.) to dimensions L7, LB, and LE.

Kinetix VPAR Electric Cylinder Dimensions (parallel configuration, Frame 32) ⁽¹⁾

Electric Cylinder Cat. No.	L71 mm (in.)
VPAR-x1100B-P2B/D/E	326.3 (12.8)
VPAR-x1200B-P2B/D/E	426.3 (16.8)
VPAR-x1300B-P2B/D/E	526.3 (20.7)
VPAR-x1400B-P2B/D/E	626.3 (24.6)

(1) For the complete dimension of the parallel configuration electric cylinders, use the inline dimensions for an electric cylinder with the same rod-stroke length and the dimensions from this table.

Actuators are designed to metric dimensions. Inch dimensions are approximate conversions from millimeters. Dimensions without tolerances are for reference.

Kinetix VPAR Electric Cylinders (Frame 40)

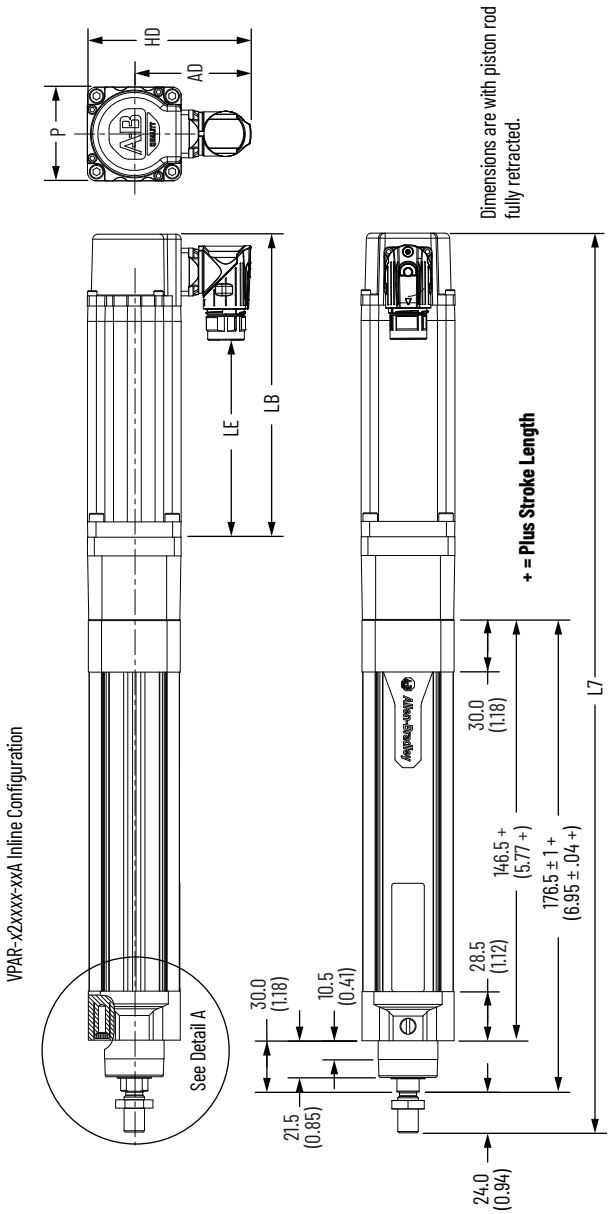
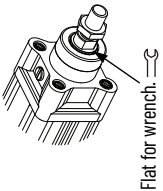
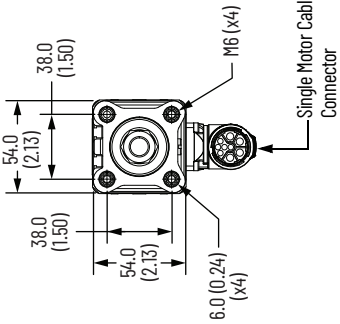

Dimensions are in mm (in.).

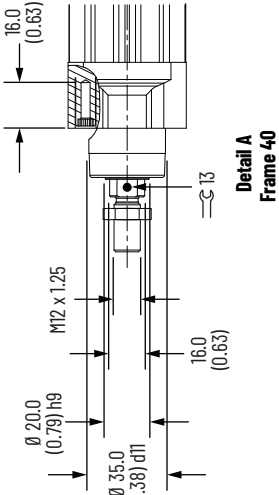
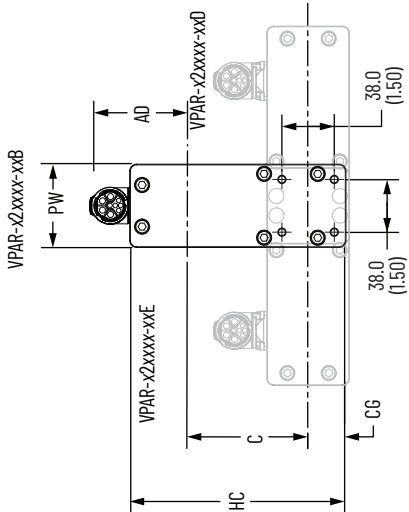
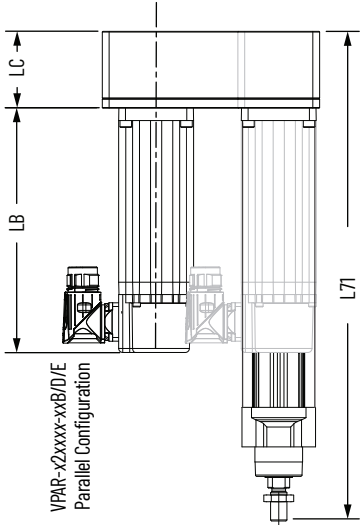

Kinetix VPAR Electric Cylinder Dimensions (inline, Frame 40)

Electric Cylinder Cat. No.	L7 ⁽¹⁾ mm (in.)	LB ⁽¹⁾ mm (in.)	LE ⁽¹⁾ mm (in.)	P mm (in.)	AD mm (in.)	HD mm (in.)
VPAR-x2100C-P2A	522.8 (20.58)	173.1 (6.81)	110.3 (4.34)	55.0 (2.17)	69.5 (2.74)	97.0 (3.82)
VPAR-x2200C-P2A	622.8 (24.52)					
VPAR-x2300C-P2A	722.8 (28.46)					
VPAR-x2400C-P2A	822.8 (32.39)					
VPAR-x2600C-P2A	1022.8(40.27)					
VPAR-x2100F-P2A	499.6 (19.67)	149.9 (5.90)	87.1 (3.43)	70.0 (2.76)	77.0 (3.03)	112.0 (4.41)
VPAR-x2200F-P2A	599.6 (23.61)					
VPAR-x2300F-P2A	699.6 (27.54)					
VPAR-x2400F-P2A	799.6 (31.48)					
VPAR-x2600F-P2A	999.6 (39.35)					

(1) If you are ordering an VPAR-x2xxx-P4x actuator with brake, add 30.6 mm (1.20 in.) to dimensions L7, LB, and LE.

Kinetix VPAR Electric Cylinder Dimensions (parallel, Frame 40) ⁽¹⁾

Electric Cylinder Cat. No.	L71 mm (in.)	LC mm (in.)	HC mm (in.)	C ⁽²⁾ mm (in.)	CG mm (in.)	PW mm (in.)
VPAR-x2100C-P2B/D/E	356.8 (14.05)	56.3 (2.22)	157.0 (6.18)	90.0 (3.54)	27.0 (1.06)	60.0 (2.36)
VPAR-x2200C-P2B/D/E	456.8 (17.98)					
VPAR-x2300C-P2B/D/E	556.8 (21.92)					
VPAR-x2400C-P2B/D/E	656.8 (25.86)					
VPAR-x2600C-P2B/D/E	856.8 (33.73)					
VPAR-x2100F-P2B/D/E	369.8 (14.56)	69.3 (2.73)	189.0 (7.44)	100.0 (3.94)	38.0 (1.50)	86.0 (3.39)
VPAR-x2200F-P2B/D/E	469.8 (18.50)					
VPAR-x2300F-P2B/D/E	569.8 (22.43)					
VPAR-x2400F-P2B/D/E	669.8 (26.37)					
VPAR-x2600F-P2B/D/E	869.8 (34.24)					

(1) For complete dimensions of the parallel configuration electric cylinders, use the inline dimensions for an electric cylinder with the same rod-stroke length and the dimensions from this table.

(2) The tolerance for this dimension is ±1.0 mm (0.04 in.).

Kinetix VPAR Electric Cylinders (Frame 63)

Dimensions are in mm (in.).

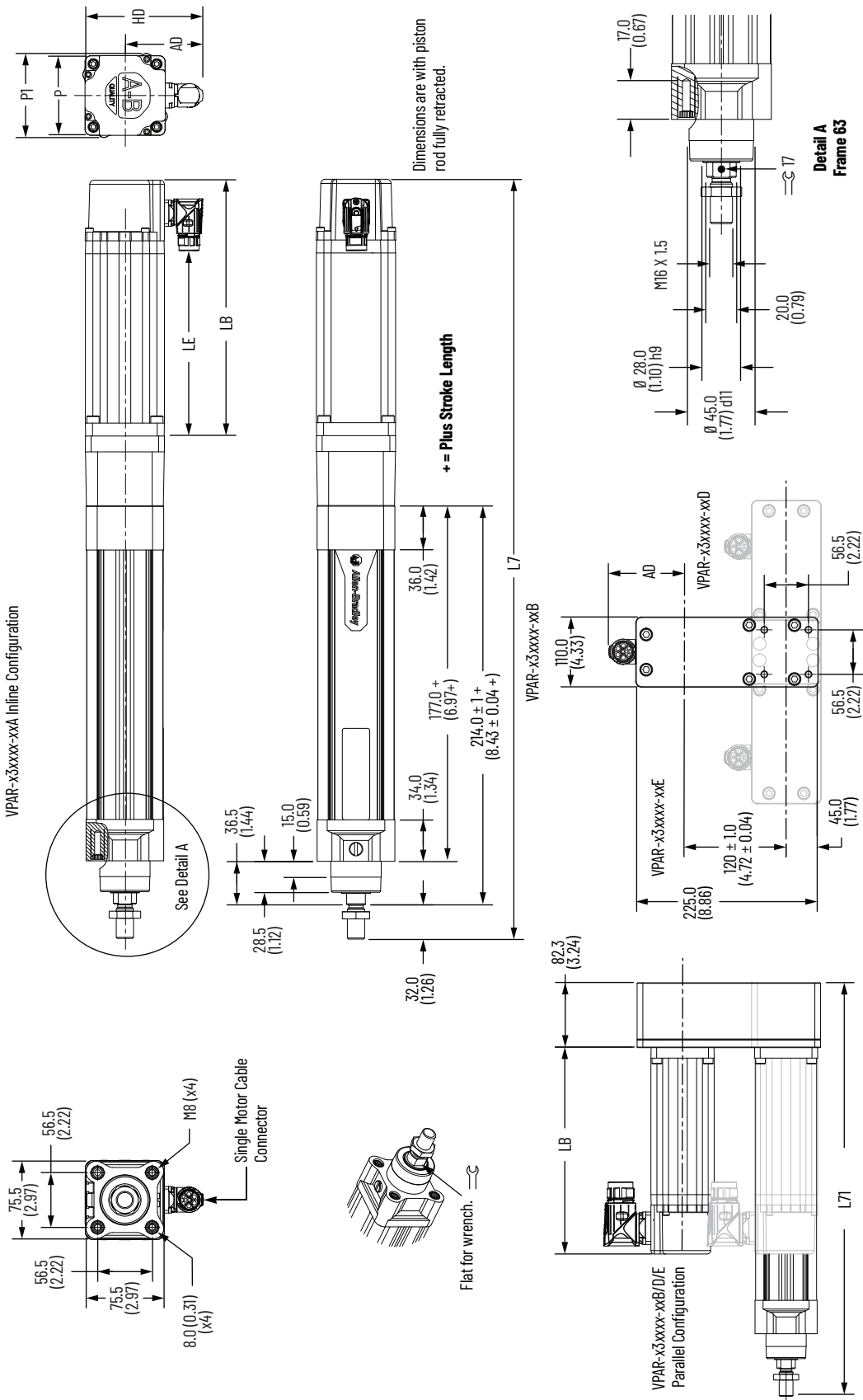

Kinetix VPAR Electric Cylinder Dimensions (inline, Frame 63)

Electric Cylinder Cat. No.	L7 ⁽¹⁾ mm (in.)	LB ⁽¹⁾ mm (in.)	LE ⁽¹⁾ mm (in.)	P mm (in.)	P1 mm (in.)	AD mm (in.)	HD mm (in.)
VPAR-x3100E-x2A	598.5 (23.56)	181.4 (7.14)	119.7 (4.71)	89.4 (3.52)	94.4 (3.72)	86.5 (3.41)	131.2 (5.17)
VPAR-x3200E-x2A	698.5 (27.50)						
VPAR-x3300E-x2A	798.5 (31.44)						
VPAR-x3400E-x2A	898.5 (35.37)						
VPAR-x3600E-x2A	1098.5 (43.25)						
VPAR-x3800E-x2A	1298.5 (51.12)						
VPAR-x3100H-x2A	577.9 (22.752)	152.4 (6.00)	90.7 (3.57)	98.3 (3.87)	101.5 (4.00)	90.8 (3.57)	140.0 (5.51)
VPAR-x3200H-x2A	677.9 (26.69)						
VPAR-x3300H-x2A	777.9 (30.63)						
VPAR-x3400H-x2A	877.9 (34.56)						
VPAR-x3600H-x2A	1077.9 (42.44)						
VPAR-x3800H-x2A	1277.9 (50.31)						

(1) If you are ordering an VPAR-x3xxxE-x4x actuator with brake, add 34.5 mm (1.36 in.) to dimensions L7, LB, and LE.
 If you are ordering an VPAR-x3xxxH-x4x actuator with brake, add 48.5 mm (1.91 in.) to dimensions L7, LB, and LE.

Kinetix VPAR Electric Cylinder Dimensions (parallel, Frame 63)

Electric Cylinder Cat. No.	L71 mm (in.)
VPAR-x3100x-x2B/D/E	428.3 (16.86)
VPAR-x3200x-x2B/D/E	528.3 (20.80)
VPAR-x3300x-x2B/D/E	628.3 (24.74)
VPAR-x3400x-x2B/D/E	728.3 (28.67)
VPAR-x3600x-x2B/D/E	928.3 (36.55)
VPAR-x3800x-x2B/D/E	1128.3 (44.42)

Dimensions - Kinetix MPAR Electric Cylinders

Kinetix MPAR Electric Cylinders Dimensions (Frame 32)

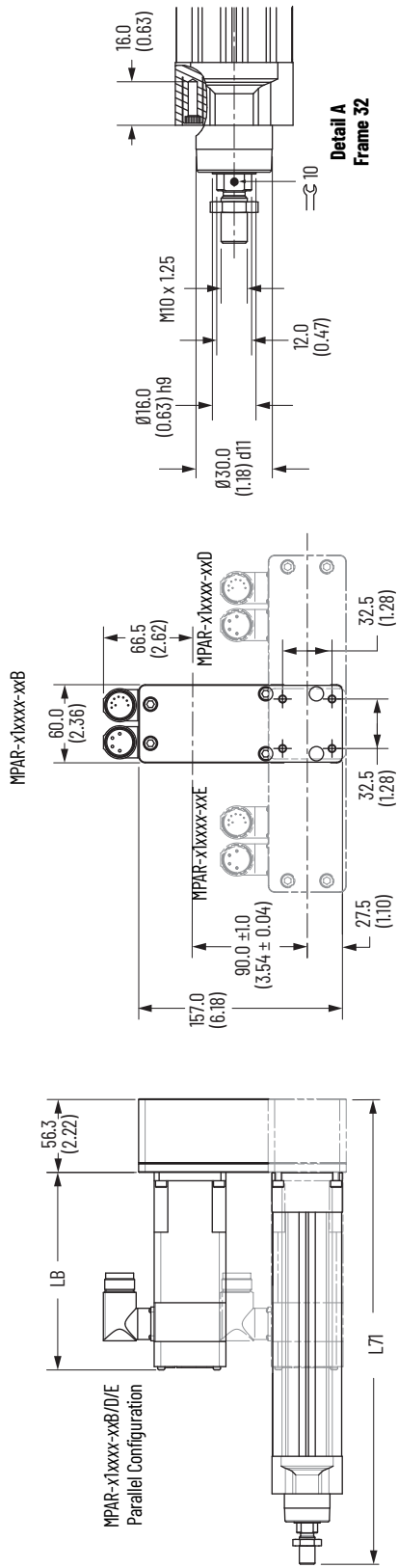
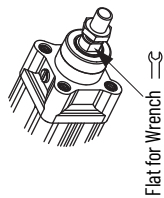
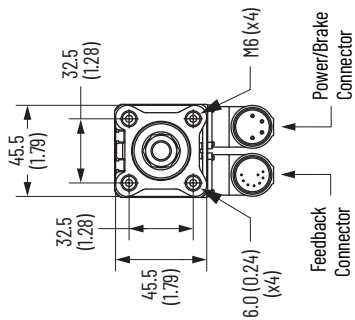
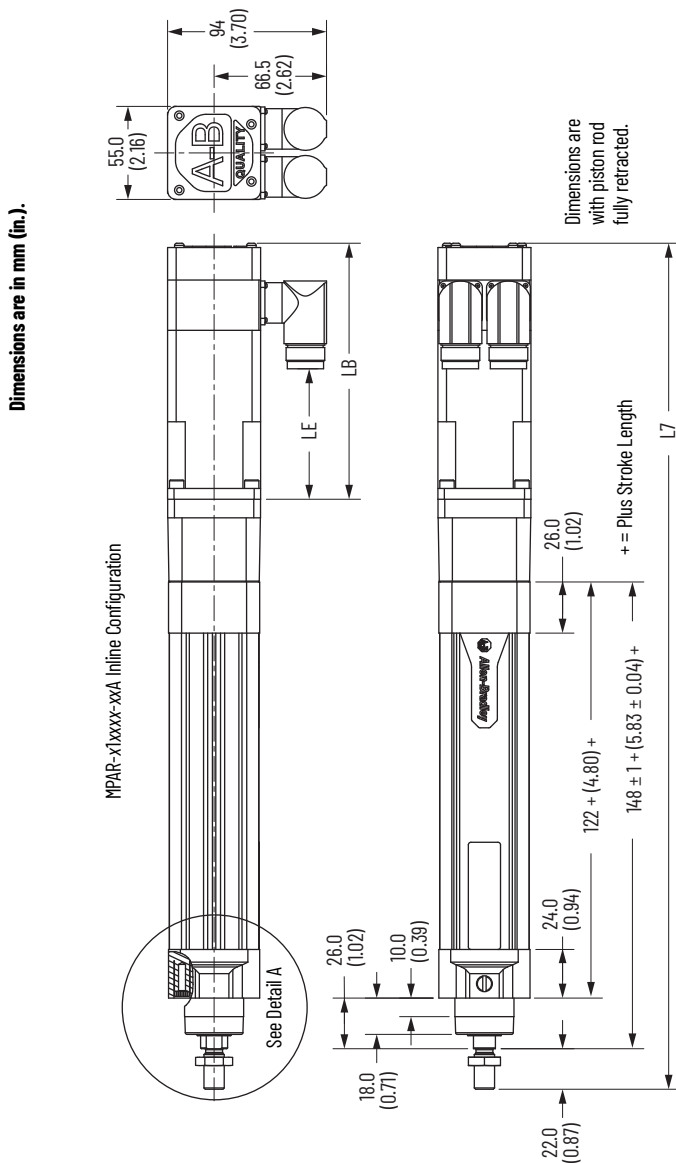

Kinetix MPAR Electric Cylinder Dimensions (inline configuration, Frame 32)

Electric Cylinder Cat. No.	L7 (1) mm (in.)	LB (1) mm (in.)	LE (2) mm (in.)
MPAR-x1100B-V2A	445.7 (17.55)	126.5 (4.98)	52.4 (2.06)
MPAR-x1200B-V2A	545.7 (21.48)		
MPAR-x1300B-V2A	645.7 (25.42)		
MPAR-x1400B-V2A	745.7 (29.36)		
MPAR-x1100E-V2A	470.7 (18.53)	151.5 (5.96)	77.2 (3.04)
MPAR-x1200E-V2A	570.7 (22.47)		
MPAR-x1300E-V2A	670.7 (26.41)		
MPAR-x1400E-V2A	770.7 (30.34)		

- (1) If you are ordering an MPAR-x1xxx-V4x actuator with brake, add 36.1 mm (1.42 in.) to dimensions L7 and LB.
- (2) If you are ordering an MPAR-x1xxx-V4x actuator with brake, add 33.4 mm (1.31 in.) to dimension LE.

Kinetix MPAR Electric Cylinder Dimensions (parallel configuration, Frame 32)

Electric Cylinder (1) Cat. No.	L71 mm (in.)
MPAR-x1100B-V2B/D/E	326.3 (12.8)
MPAR-x1200B-V2B/D/E	426.3 (16.8)
MPAR-x1300B-V2B/D/E	526.3 (20.7)
MPAR-x1400B-V2B/D/E	626.3 (24.6)

- (1) For the complete dimension of the parallel configuration electric cylinders, use the inline dimensions for an electric cylinder with the same rod-stroke length and the dimensions from this table.

Actuators are designed to metric dimensions. Inch dimensions are approximate conversions from millimeters. Dimensions without tolerances are for reference.

Kinetix MPAR Electric Cylinders Dimensions (Frame 40)

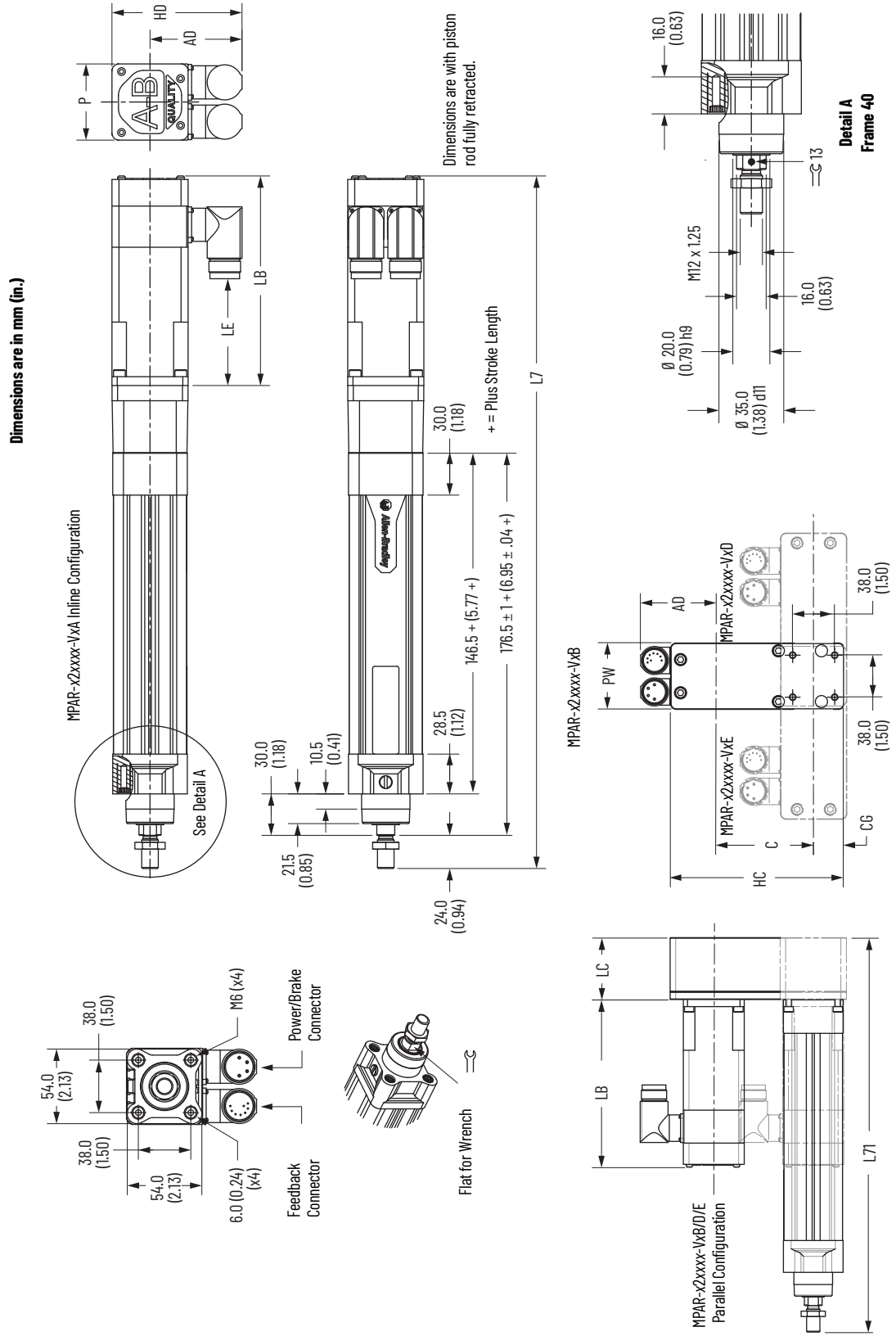

Kinetix MPAR Electric Cylinder Dimensions (inline, Frame 40)

Electric Cylinder Cat. No.	L7 ⁽¹⁾ mm (in.)	LB ⁽¹⁾ mm (in.)	LE ⁽²⁾ mm (in.)	P mm (in.)	AD mm (in.)	HD mm (in.)
MPAR-x2100C-V2A	501.2 (19.73)	151.5 (5.96)	77.2 (3.04)	55.0 (2.17)	66.5 (2.62)	94.0 (3.70)
MPAR-x2200C-V2A	601.2 (23.67)					
MPAR-x2300C-V2A	701.2 (27.61)					
MPAR-x2400C-V2A	801.2 (31.54)					
MPAR-x2600C-V2A	1001.2 (39.42)					
MPAR-x2100F-V2A	489.8 (19.28)	140.1 (5.52)	65.1 (2.56)	70.0 (2.76)	74.0 (2.91)	109.0 (4.29)
MPAR-x2200F-V2A	589.8 (23.22)					
MPAR-x2300F-V2A	689.8 (27.16)					
MPAR-x2400F-V2A	789.8 (31.09)					
MPAR-x2600F-V2A	989.8 (38.97)					

- (1) If you are ordering an MPAR-x2xxxC-V4x actuator with brake, add 36.1 mm (1.42 in.) to dimensions L7 and LB.
If you are ordering an MPAR-x2xxxF-V4x actuator with brake, add 39.0 mm (1.54 in.) to dimensions L7 and LB.
- (2) If you are ordering an MPAR-x2xxxC-V4x actuator with brake, add 33.4 mm (1.31 in.) to dimension LE.
If you are ordering an MPAR-x2xxxF-V4x actuator with brake, add 24.7 mm (0.97 in.) to dimension LE.

Kinetix MPAR Electric Cylinder Dimensions (parallel, Frame 40)

Electric Cylinder ⁽¹⁾ Cat. No.	L71 mm (in.)	LC mm (in.)	HC mm (in.)	C ⁽²⁾ mm (in.)	CG mm (in.)	PW mm (in.)
MPAR-x2100C-V2/D/E	356.8 (14.05)	56.3 (2.22)	157.0 (6.18)	90.0 (3.54)	27.0 (1.06)	60.0 (2.36)
MPAR-x2200C-V2/D/E	456.8 (17.98)					
MPAR-x2300C-V2/D/E	556.8 (21.92)					
MPAR-x2400C-V2/D/E	656.8 (25.86)					
MPAR-x2600C-V2/D/E	856.8 (33.73)					
MPAR-x2100F-V2/D/E	369.8 (14.56)	69.3 (2.73)	188.5 (7.42)	100.0 (3.94)	38.0 (1.50)	86.0 (3.39)
MPAR-x2200F-V2/D/E	469.8 (18.50)					
MPAR-x2300F-V2/D/E	569.8 (22.43)					
MPAR-x2400F-V2/D/E	669.8 (26.37)					
MPAR-x2600F-V2/D/E	356.8 (14.05)					

- (1) For complete dimensions of the parallel configuration electric cylinders, use the inline dimensions for an electric cylinder with the same rod-stroke length and the dimensions from this table.
- (2) The tolerance for this dimension is ±1.0 mm (0.04 in.).

Actuators are designed to metric dimensions. Inch dimensions are approximate conversions from millimeters. Dimensions without tolerances are for reference.

Kinetix MPAR Electric Cylinders Dimensions (Frame 63)

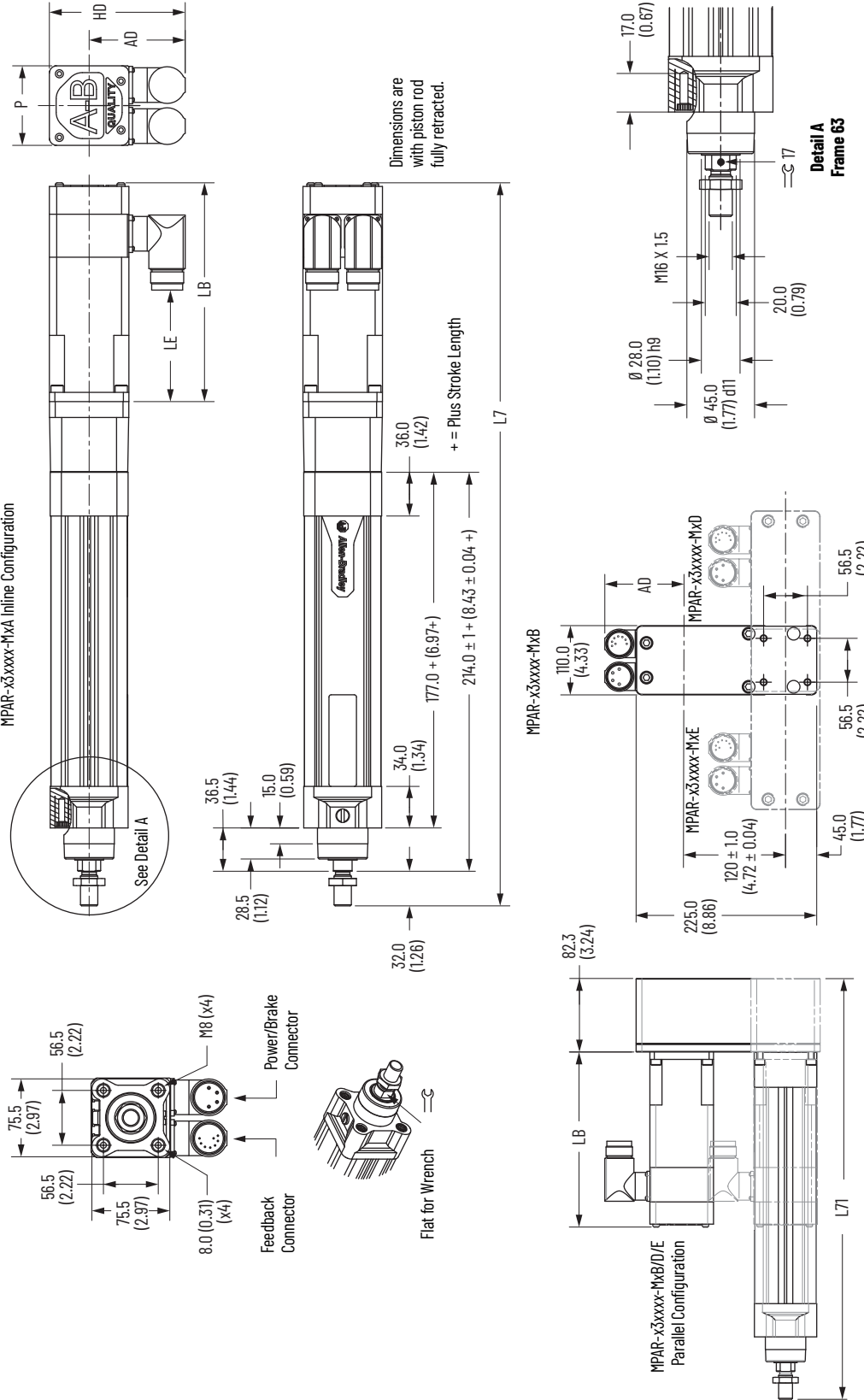

Kinetix MPAR Electric Cylinder Dimensions (inline, Frame 63)

Electric Cylinder Cat. No.	L7 ⁽¹⁾ mm (in.)	LB ⁽¹⁾ mm (in.)	LE ⁽²⁾ mm (in.)	P mm (in.)	AD mm (in.)	HD mm (in.)
MPAR-x3100E-M2A	595.9 (23.46)	178.8 (7.04)	121.5 (4.78)	89.4 (3.52)	80.9 (3.19)	125.7 (4.95)
MPAR-x3200E-M2A	695.9 (27.40)					
MPAR-x3300E-M2A	795.9 (31.33)					
MPAR-x3400E-M2A	895.9 (35.27)					
MPAR-x3600E-M2A	1095.9 (43.15)					
MPAR-x3800E-M2A	1295.9 (51.02)					
MPAR-x3100H-M2A	574.8 (22.63)	149.8 (5.90)	92.5 (3.64)	98.3 (3.87)	83.9 (3.30)	132.8 (5.23)
MPAR-x3200H-M2A	674.8 (26.57)					
MPAR-x3300H-M2A	774.8 (30.50)					
MPAR-x3400H-M2A	874.8 (34.44)					
MPAR-x3600H-M2A	1074.8 (42.31)					
MPAR-x3800H-M2A	1274.8 (50.19)					

- (1) If you are ordering an MPAR-x3xxxE-M4x actuator with brake, add 34.5 mm (1.36 in.) to dimensions L7 and LB.
If you are ordering an MPAR-x3xxxH-M4x actuator with brake, add 48.5 mm (1.91 in.) to dimensions L7 and LB.
- (2) If you are ordering an MPAR-x3xxxE-M4x actuator with brake, add 34.5 mm (1.36 in.) to dimension LE.
If you are ordering an MPAR-x3xxxH-M4x actuator with brake, add 48.5 mm (1.91 in.) to dimension LE.

Kinetix MPAR Electric Cylinder Dimensions (parallel, Frame 63)

Electric Cylinder Cat. No.	L71 mm (in.)
MPAR-x3100x-M2B/D/E	428.3 (16.86)
MPAR-x3200x-M2B/D/E	528.3 (20.80)
MPAR-x3300x-M2B/D/E	628.3 (24.74)
MPAR-x3400x-M2B/D/E	728.3 (28.67)
MPAR-x3600x-M2B/D/E	928.3 (36.55)
MPAR-x3800x-M2B/D/E	1128.3 (44.42)

Dimensions - Electric Cylinders (Replacement components)

Electric Cylinder Dimensions (Frame 32, 40, and 63)

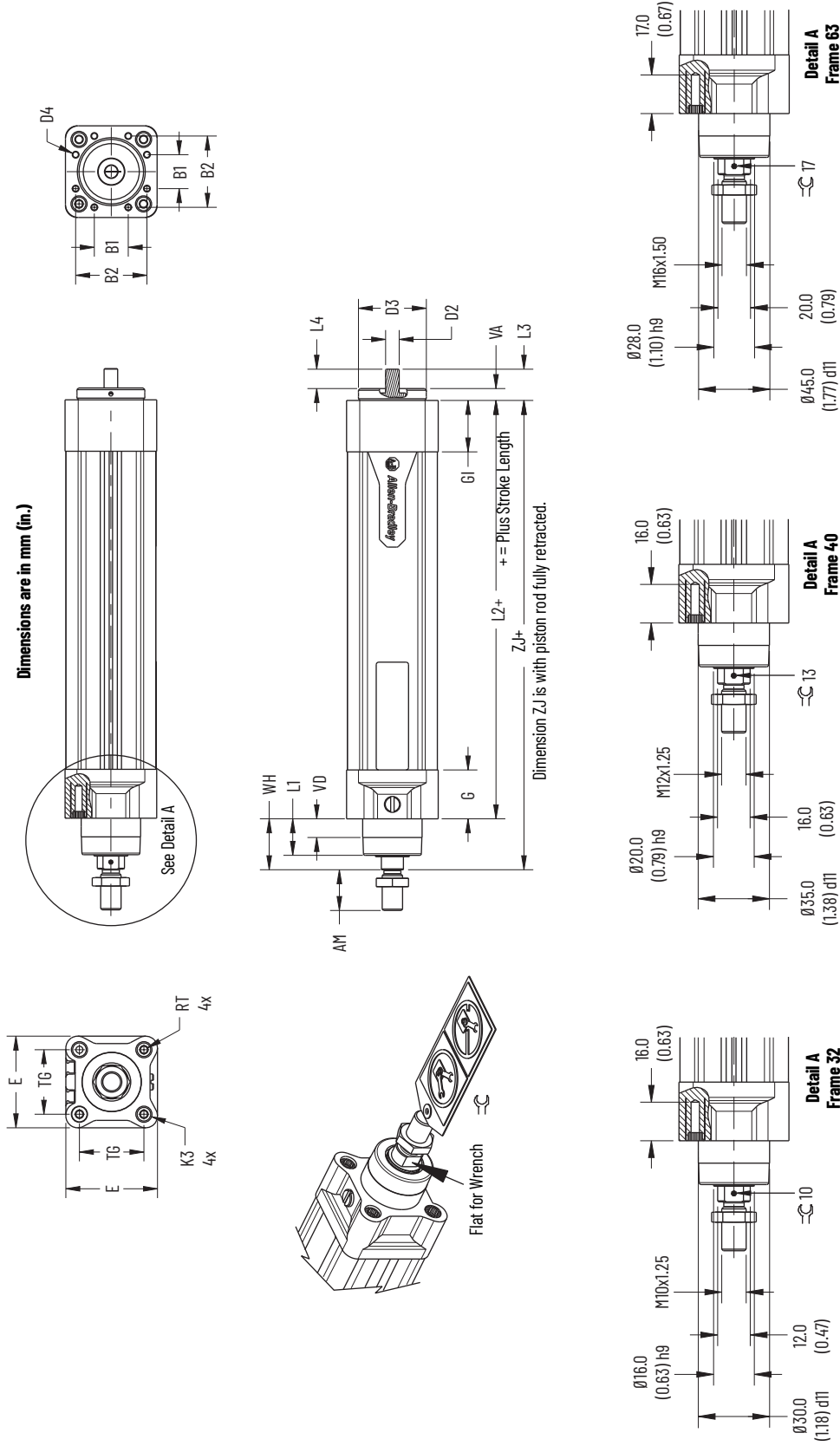

Electric Cylinder Replacement Components

Electric Cylinder Cat. No.	Frame	AM mm (in.)	G mm (in.)	G1 mm (in.)	L1 mm (in.)	L2 mm (in.)	L3 mm (in.)	L4 mm (in.)	ZJ (1) mm (in.)	VA mm (in.)	VD mm (in.)	WH mm (in.)	D2 mm (in.) h6	D3 mm (in.) f7	D4	B1 mm (in.)	B2 mm (in.)	E mm (in.)	RT	TG mm (in.)	K3 mm (in.)
VPAR-X1xxxB	32	22.0 (0.87)	24.0 (0.94)	26.0 (1.02)	18.0 (0.71)	122.0 (4.80)	15.9 (0.63)	8.0 (0.31)	148.0 (5.83)	7.0 (0.28)	10.0 (0.39)	26.0 (1.02)	6.0 (0.24)	32.0 (1.26)	M3	19.0 (0.75)	32.0 (1.26)	45.5 (1.79)	M6	32.5 (1.28)	6.0 (0.24)
MPAR-X1xxxB																					
VPAR-X1xxxE																					
MPAR-X1xxxE																					
VPAR-X2xxxC	40	24.0 (0.94)	28.0 (1.14)	30.0 (1.18)	21.5 (0.85)	146.5 (5.77)	18.4 (0.72)	14.0 (0.55)	176.5 (6.95)	7.0 (0.28)	10.5 (0.41)	30.0 (1.18)	8.0 (0.31)	40.0 (1.57)	M4	20.0 (0.79)	42.0 (1.65)	54.0 (2.13)	M6	38.0 (1.50)	6.0 (0.24)
MPAR-X2xxxC																					
VPAR-X2xxxF																					
MPAR-X2xxxF																					
VPAR-X3xxxE	63	32.0 (1.26)	34.0 (1.34)	36.0 (1.42)	28.5 (1.12)	177.0 (6.97)	23.5 (0.93)	17.0 (0.67)	214.0 (8.43)	9.0 (0.35)	15.0 (0.59)	36.5 (1.44)	12.0 (0.47)	60.0 (2.36)	M5	31.0 (1.22)	62.0 (2.44)	75.5 (2.97)	M8	56.5 (2.22)	8.0 (0.31)
MPAR-X3xxxE																					
VPAR-X3xxxH																					
MPAR-X3xxxH																					

(1) The tolerance for this dimension is ±1.0 mm (0.039 in.).

These replacement cylinders are available in the event of bent rods or other damage to the cylinder. For replacement motors, couplings, and belts, refer to Kinetix VPAR and MPAR Electric Cylinder Replacement Parts Installation Instructions, publication [MPAR-IN002](#).

Actuators are designed to metric dimensions. Inch dimensions are approximate conversions from millimeters. Dimensions without tolerances are for reference.

Kinetix VPAR and MPAR Electric Cylinder Mounting Accessories

Components are designed to metric dimensions. Inch dimensions are approximate conversions from millimeters. Dimensions without tolerances are for reference.

Foot Mount Attachment

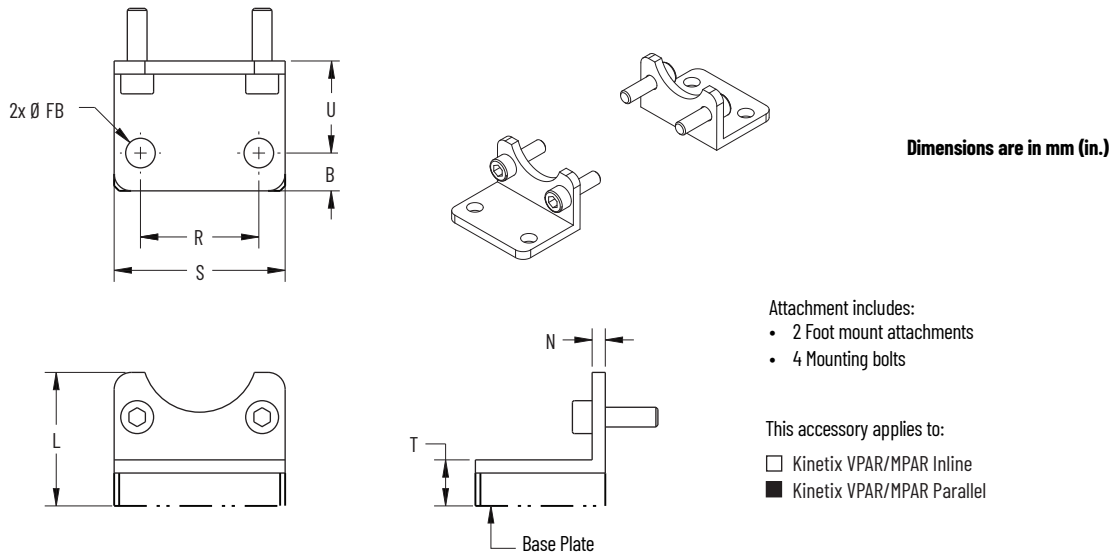

Cat. No. (1)	Frame	T mm (in.)	N mm (in.)	FB mm (in.)	L mm (in.)	B mm (in.)	U mm (in.)	R mm (in.)	S mm (in.)
MPAR-NP622640	32	4.0 (0.16)	4.0 (0.16)	7.0 (0.27)	37.2 (1.46)	10.0 (0.39)	24.0 (0.94)	32.0 (1.26)	45.0 (1.77)
MPAR-NP622641	40	14.0 (2) (0.55)	4.0 (0.16)	9.0 (0.35)	40.6 (2) (1.60)	11.5 (0.45)	28.0 (1.10)	36.0 (1.42)	52.0 (2.05)
MPAR-NP622642	63	15.0 (2) (0.59)	5.0 (0.20)	9.0 (0.35)	52.5 (2) (2.07)	14.0 (0.55)	32.0 (1.26)	50.0 (1.97)	75.0 (2.95)

(1) Material is zinc plated steel.
 (2) This dimension includes base plate provided with frame 40 and frame 63 foot mount attachments.

Flange Mounting Attachment

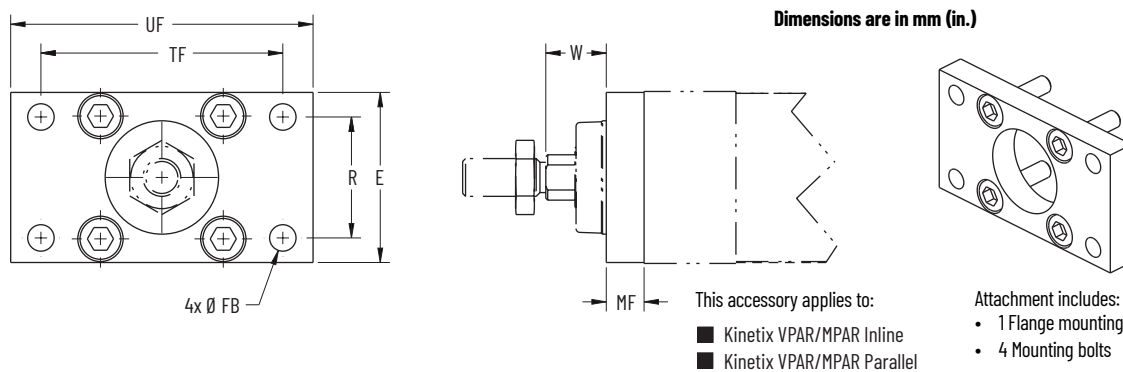

Cat. No. (1)	Frame	E mm (in.)	FB mm (in.)	MF mm (in.)	R mm (in.)	TF mm (in.)	UF mm (in.)	W mm (in.)
MPAR-NA174376	32	45.0 (1.77)	7.0 (0.28)	10.0 (0.39)	32.0 (1.26)	64.0 (2.52)	80.0 (3.15)	16.0 (0.63)
MPAR-NA174377	40	52.0 (2.05)	9.0 (0.35)	10.0 (0.39)	36.0 (1.42)	72.0 (2.83)	90.0 (3.54)	20.0 (0.79)
MPAR-NA174379	63	75.0 (2.95)	9.0 (0.35)	12.0 (0.47)	50.0 (1.97)	100 (3.94)	120 (4.72)	24.5 (0.96)

(1) Material is zinc plated steel.

Trunnion Flange Attachment

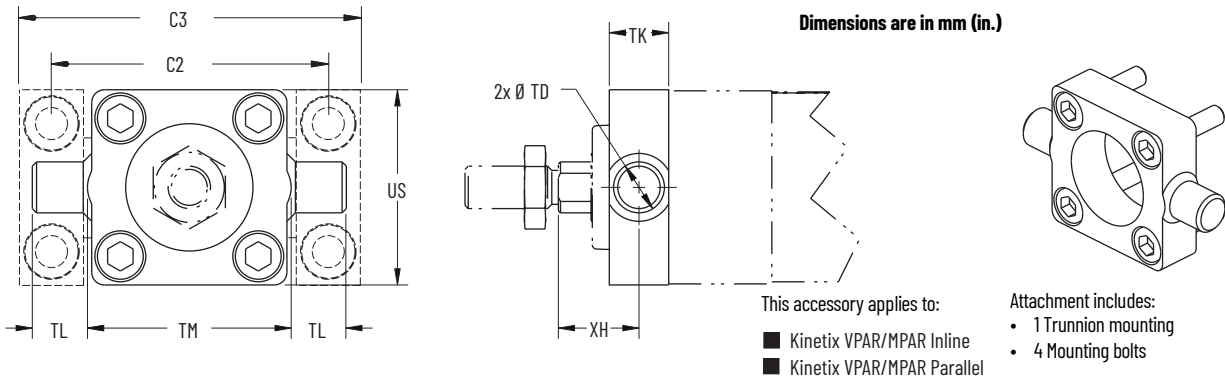

Cat. No. (1)	Frame	C2 (2) mm (in.)	C3 (2) mm (in.)	TD mm (in.) e9	TK mm (in.)	TL mm (in.)	TM mm (in.)	US mm (in.)	XH mm (in.)
MPAR-NA622625	32	71.0 (2.80)	86.0 (3.39)	12.0 (0.47)	14.0 (0.55)	13.0 (0.51)	50.0 (1.97)	46.0 (1.81)	19.0 (0.75)
MPAR-NA622626	40	87.0 (3.43)	105 (4.13)	16.0 (0.63)	19.0 (0.75)	17.0 (0.67)	63.0 (2.48)	59.0 (2.08)	20.5 (0.81)
MPAR-NA622627	63	116 (4.57)	136 (5.35)	20.0 (0.79)	24.0 (0.94)	22.0 (0.87)	90.0 (3.54)	84.0 (2.96)	24.5 (0.96)

(1) Material zinc plated steel.
 (2) These dimensions are drawn to the trunnion support blocks as shown on [page 106](#) (not included with the trunnion flange attachment).

Trunnion Support Block Attachments

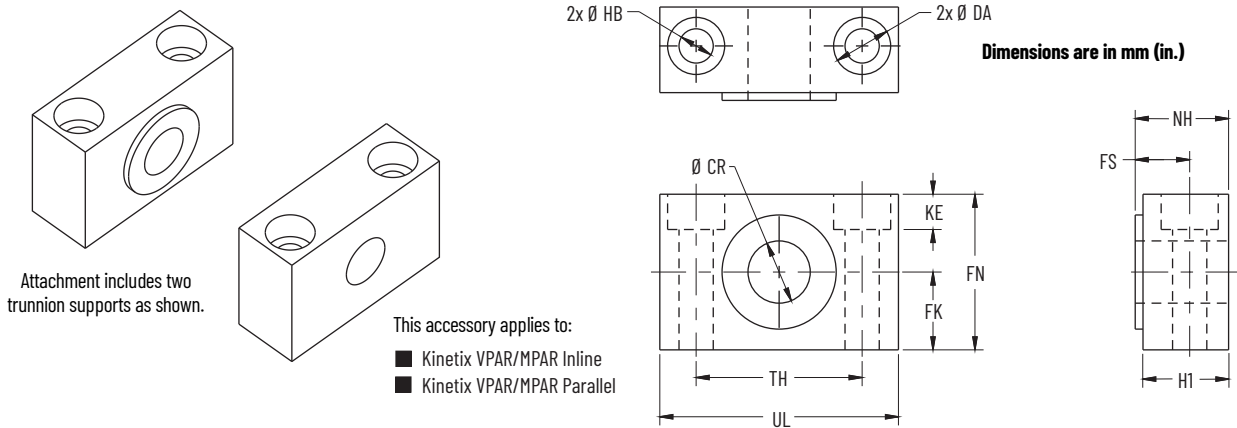

Cat. No. (1)	Frame	CR mm (in.) H7	DA mm (in.)	FK (2) mm (in.)	FN mm (in.)	FS mm (in.)	H1 mm (in.)	HB mm (in.)	KE mm (in.)	NH mm (in.)	TH mm (in.)	UL mm (in.)
MPAR-NA622628	32	12.0 (0.47)	11.0 (0.43)	15.0 (0.59)	30.0 (1.18)	10.5 (0.41)	15.0 (0.59)	6.6 (0.26)	6.8 (0.27)	18.0 (0.71)	32.0 (1.26)	46.0 (1.81)
MPAR-NA622629	40	16.0 (0.63)	15.0 (0.59)	18.0 (0.71)	36.0 (1.42)	12.0 (0.47)	18.0 (0.71)	9.0 (0.35)	9.0 (0.35)	21.0 (0.83)	36.0 (1.42)	55.0 (2.17)
MPAR-NA622630	63	20.0 (0.79)	18.0 (0.71)	20.0 (0.79)	40.0 (1.57)	13.0 (0.51)	20.0 (0.79)	11.0 (0.43)	11.0 (0.43)	23.0 (0.91)	42.0 (1.65)	65.0 (2.56)

(1) Material is zinc plated steel. Sintered bronze bearing.
 (2) Tolerance for this dimension is ±0.1 mm (±0.0039 in.).

Swivel Flange (pin, narrow) Attachment

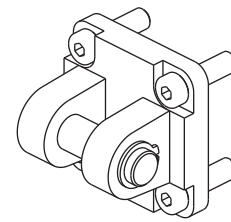
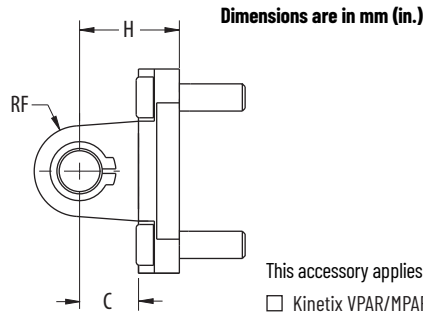
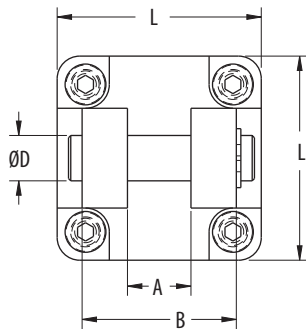

This accessory applies to:
 Kinetix VPAR/MPAR Inline
 Kinetix VPAR/MPAR Parallel

- Attachment includes:
- 1 Swivel flange
 - 1 Pivot pin
 - 4 Mounting screws
 - 1 Retaining clip

Cat. No. (1)	Frame	D mm (in.)	A mm (in.) H14	B mm (in.)	L mm (in.)	C mm (in.)	H (2) mm (in.)	RF mm (in.)
MPAR-NP174383	32	10.0 (0.39)	14.0 (0.55)	34.0 (1.34)	45.0 (1.77)	13.0 (0.51)	22.0 (0.86)	10.0 (0.39)
MPAR-NP174384	40	12.0 (0.47)	16.0 (0.63)	40.0 (1.57)	52.0 (2.05)	16.0 (0.63)	25.0 (0.98)	12.0 (0.47)
MPAR-NP174386	63	16.0 (0.63)	21.0 (0.82)	51.0 (2.01)	75.0 (2.95)	21.0 (0.82)	32.0 (0.26)	18.0 (0.71)

(1) Material is die cast aluminum. Zinc plated steel dowel.
 (2) Tolerance for this dimension is ±0.2 mm (±0.0079 in.).

Swivel Flange (spherical bearing) Attachment

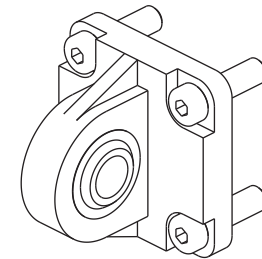
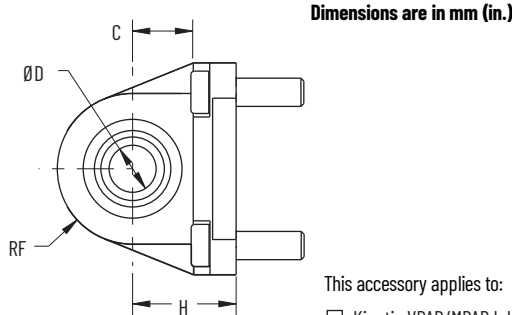
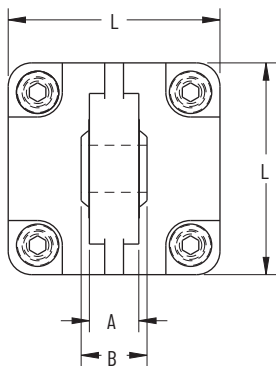

This accessory applies to:
 Kinetix VPAR/MPAR Inline
 Kinetix VPAR/MPAR Parallel

- Attachment includes:
- 1 Swivel flange with spherical bearing
 - 4 Mounting screws

Cat. No. (1)	Frame	D mm (in.) H7	A mm (in.)	B (2) mm (in.)	L mm (in.)	C mm (in.)	H (2) mm (in.) JS15	RF mm (in.)
MPAR-NP622637	32	10.0 (0.39)	10.5 (0.41)	14.0 (0.55)	45.0 (1.77)	13.0 (0.51)	22.0 (0.86)	16.0 (0.63)
MPAR-NP622638	40	12.0 (0.47)	12.0 (0.47)	16.0 (0.63)	52.0 (2.05)	16.0 (0.63)	25.0 (0.98)	19.0 (0.75)
MPAR-NP622639	63	16.0 (0.63)	15.0 (0.59)	21.0 (0.82)	75.0 (2.95)	21.0 (0.82)	32.0 (0.26)	24.0 (0.94)

(1) Material is die cast aluminum.
 (2) Tolerance for this dimension is +0, -0.1 mm (+0, -0.0039 in.).

Trunnion Mounting Attachment

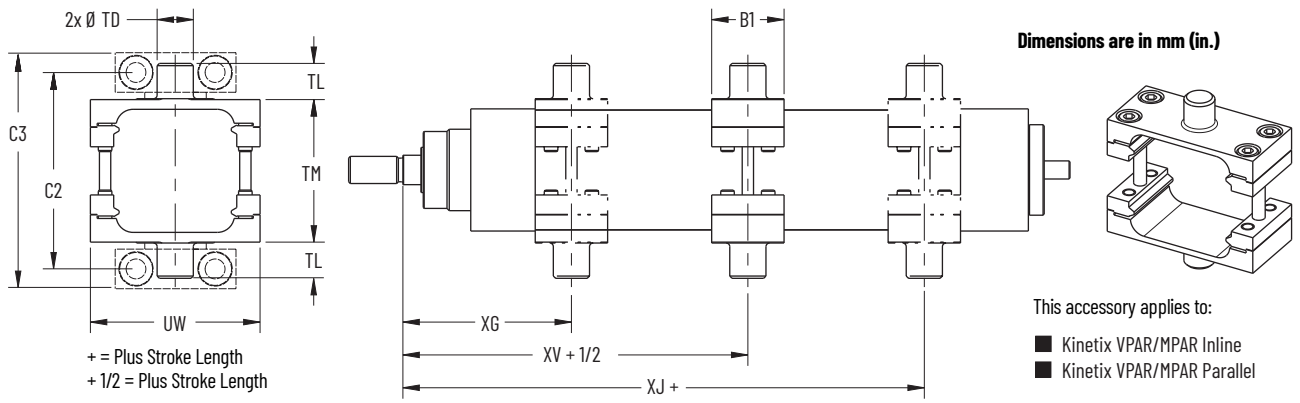

Cat. No. (1) (2)	Frame	B1 mm (in.)	C2 (3) mm (in.)	C3 (3) mm (in.)	TD mm (in.)	TL mm (in.)	TM mm (in.)	UW mm (in.)	XG mm (in.)	XV mm (in.)	XJ mm (in.)	Tightening Torque N•m (lb•in)
MPAR-NA163525	32	30.0 (1.18)	71.0 (2.80)	86.0 (3.39)	12.0 (0.47)	12.0 (0.47)	50.0 (1.97)	65.0 (2.56)	65.0 (2.56)	86.0 (3.39)	107 (4.21)	4.0 (35.4) (4)
MPAR-NA163526	40	32.0 (1.26)	87.8 (3.46)	105.8 (4.17)	16.0 (0.63)	16.0 (0.63)	63.0 (2.48)	75.0 (2.95)	74.0 (2.91)	102.5 (4.04)	130.5 (5.14)	8.0 (70.7) (4)
MPAR-NA163528	63	41.0 (1.61)	117.6 (4.63)	137.6 (5.42)	20.0 (0.79)	20.0 (0.79)	90.0 (3.54)	105 (4.13)	91.5 (3.60)	124.5 (4.90)	157.5 (6.20)	18.0 (159) (5)

- (1) Material is zinc plated steel.
- (2) You can attach the trunnion mounting kit anywhere along the cylinder barrel.
- (3) These dimensions are drawn to the trunnion support blocks as shown on [page 106](#) (not included with the trunnion mounting attachment).
- (4) Tolerance for this tightening torque value is +1.0 N•m (+8.8 lb•in).
- (5) Tolerance for this tightening torque value is +2.0 N•m (+17.7 lb•in).

Foot Mounting Kit

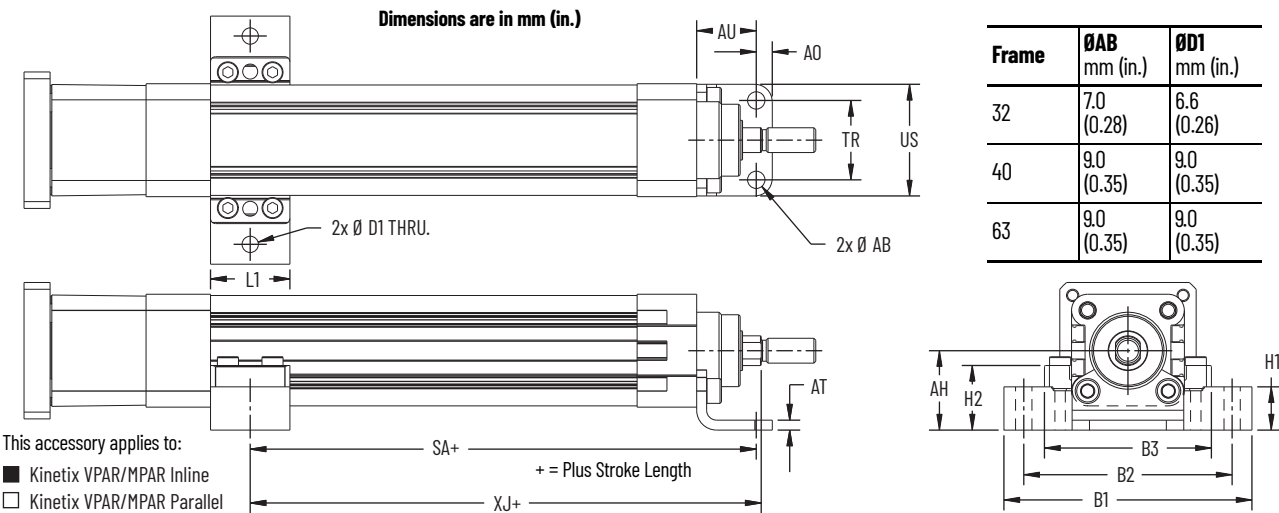

Frame	ØAB mm (in.)	ØD1 mm (in.)
32	7.0 (0.28)	6.6 (0.26)
40	9.0 (0.35)	9.0 (0.35)
63	9.0 (0.35)	9.0 (0.35)

Cat. No. (1)	Frame	AH mm (in.)	A0 mm (in.)	AT mm (in.)	AU mm (in.)	B1 mm (in.)	B2 mm (in.)	B3 mm (in.)	H1 mm (in.)	H2 mm (in.)	TR mm (in.)	US mm (in.)	XJ mm (in.)	SA mm (in.)	L1 mm (in.)
MPAR-NA622685	32	32.0 (1.26)	11 (0.43)	4.0 (0.16)	24.0 (0.94)	100 (3.94)	84.0 (3.31)	64.8 (2.55)	17.5 (0.69)	26.1 (1.03)	32.0 (1.26)	45.0 (1.77)	105.7 (4.16)	103.7 (4.08)	32.0 (1.26)
MPAR-NA622686	40	36.0 (1.42)	8.0 (0.31)	4.0 (0.16)	28.0 (1.10)	130 (5.12)	108 (4.25)	83.6 (3.29)	15.7 (0.62)	23.3 (0.92)	36.0 (1.42)	52.0 (2.05)	129.2 (5.09)	127.2 (5.01)	34.0 (1.34)
MPAR-NA622687	63	50.0 (1.97)	13.0 (0.49)	5.0 (0.20)	32.0 (1.26)	150 (5.91)	128 (5.04)	103.0 (4.06)	22.9 (0.90)	30.4 (1.20)	50.0 (1.97)	75.0 (2.95)	158.0 (6.22)	153.5 (6.00)	41.0 (1.61)

- (1) Material is galvanized steel and subject to low corrosion stress. Contains no copper, PTFE, or silicone.

Kinetix VPAR and MPAR Electric Cylinder Rod-end Accessories

Components are designed to metric dimensions. Inch dimensions are approximate conversions from millimeters. Dimensions without tolerances are for reference.

Rod-eye Attachment

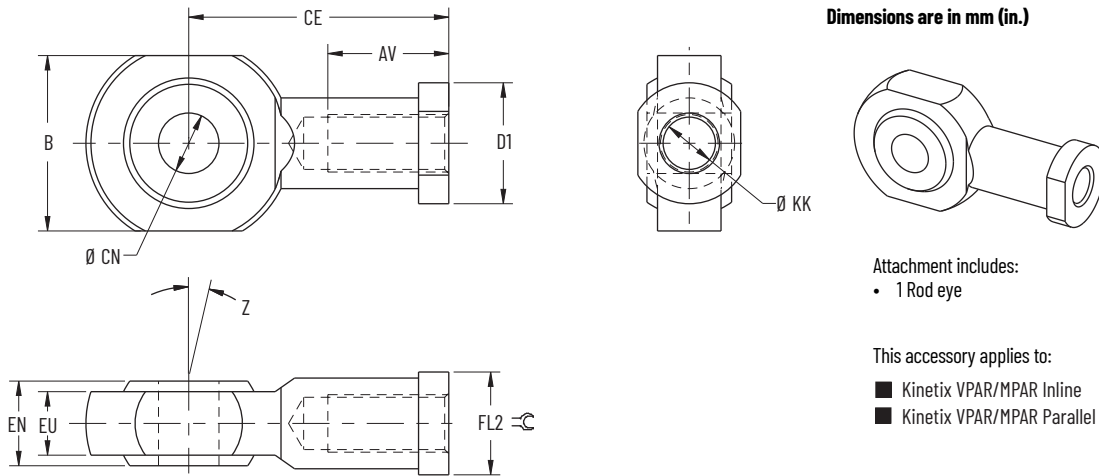

Cat. No. (1)	Frame	AV mm (in.)	B mm (in.)	CE mm (in.)	CN mm (in.)	D1 mm (in.)	EN mm (in.)	EU mm (in.)	Z Angle	FL2 mm	KK
MPAR-NE622631	32	20.0 (0.79)	29.0 (1.14)	43.0 (1.69)	10.0 (0.39)	20.0 (0.79)	14.0 (0.55)	10.5 (0.41)	13°	17	M10x1.25
MPAR-NE622632	40	22.0 (0.87)	33.0 (1.30)	50.0 (1.97)	12.0 (0.47)	23.0 (0.91)	16.0 (0.63)	12.0 (0.47)	13°	19	M12x1.25
MPAR-NE622633	63	28.0 (1.10)	43.0 (1.69)	64.0 (2.52)	16.0 (0.63)	29.0 (1.14)	21.0 (0.83)	15.0 (0.59)	15°	22	M16x1.50

(1) Material is zinc plated steel.

Rod Clevis Attachment

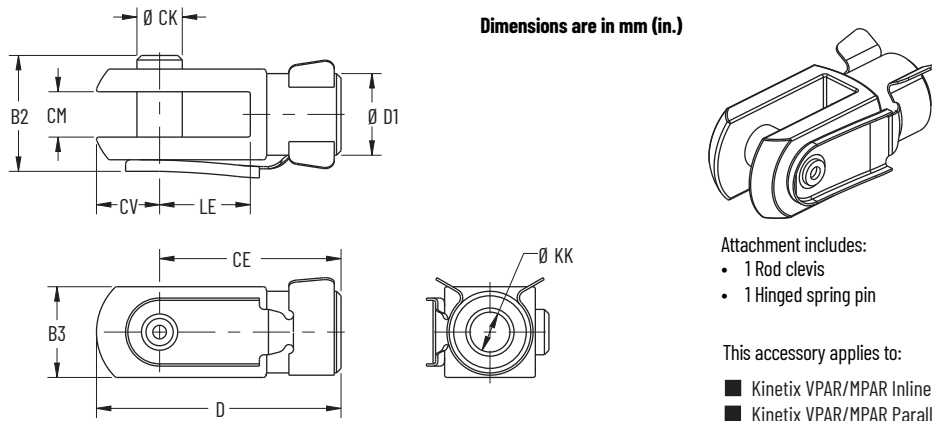

Cat. No. (1)	Frame	B2 mm (in.)	B3 mm (in.)	CE mm (in.)	CK mm (in.)	CM mm (in.)	CV mm (in.)	D mm (in.)	D1 mm (in.)	LE mm (in.)	KK
MPAR-NE622634	32	25.5 (1.00)	20.0 (0.79)	40.0 (1.57)	10.0 (0.39)	10.0 (0.39)	13.9 (0.55)	53.9 (2.12)	18.0 (0.71)	20.0 (0.79)	M10x1.25
MPAR-NE622635	40	30.5 (1.20)	24.0 (0.94)	48.0 (1.89)	12.0 (0.47)	12.0 (0.47)	16.7 (0.66)	64.7 (2.55)	20.0 (0.79)	24.0 (0.94)	M12x1.25
MPAR-NE622636	63	39.0 (1.54)	32.0 (1.26)	64.0 (2.52)	16.0 (0.63)	16.0 (0.63)	22.4 (0.88)	86.4 (3.40)	26.0 (1.02)	32.0 (1.26)	M16x1.50

(1) Material is zinc plated steel.

Self-aligning Rod Coupler Attachment

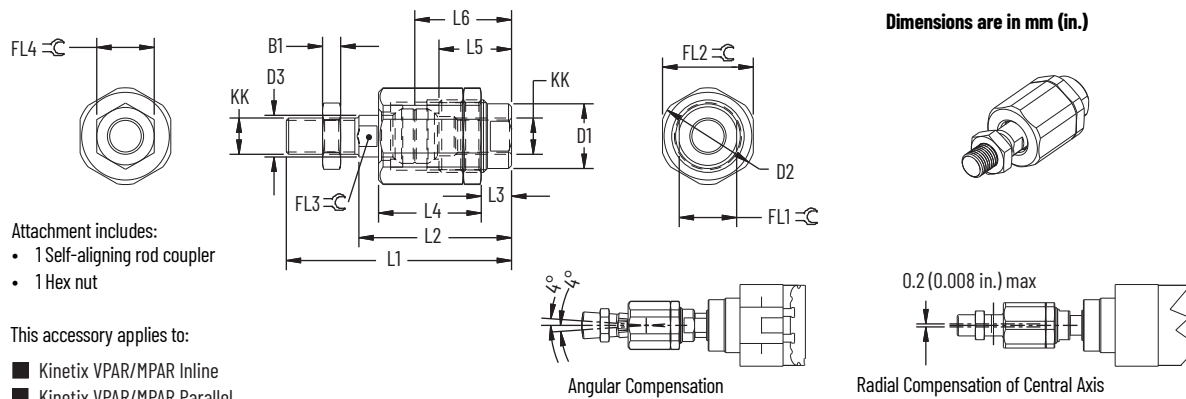

Cat. No. (1)	Frame	B1 mm (in.)	D1 mm (in.)	D2 mm (in.)	D3 mm (in.)	L1 mm (in.)	L2 mm (in.)	L3 mm (in.)	L4 mm (in.)	L5 mm (in.)	L6 mm (in.)
MPAR- NE6140	32	5.0 (0.20)	21.4 (0.84)	32.0 (1.26)	13.8 (0.54)	69.5 (2.74)	49.5 (1.95)	9.0 (0.35)	34.0 (1.34)	23.0 (0.91)	31.0 (1.22)
MPAR-NE6141	40	6.0 (0.24)	21.4 (0.84)	32.0 (1.26)	13.8 (0.54)	74.5 (2.93)	50.5 (1.99)	10.0 (0.39)	34.0 (1.34)	24.0 (0.94)	32.0 (1.26)
MPAR-NE6142	63	8.0 (0.31)	33.8 (1.33)	45.0 (1.77)	22.0 (0.87)	103 (4.06)	71.0 (2.80)	10.0 (0.39)	53.0 (2.09)	32.0 (1.26)	44.5 (1.75)

Cat. No. (1)	Frame	FL1 mm ⌀	FL2 mm ⌀	FL3 mm ⌀	FL4 mm ⌀	Radial Deviation mm (in.)	KK
MPAR-NE6140	32	19	30	12	17	±0.7 (±0.027)	M10x1.25
MPAR-NE6141	40	19	30	12	19	±0.7 (±0.027)	M12x1.25
MPAR-NE6142	63	30	41	19	24	±1.0 (±0.039)	M16x1.50

(1) Material is galvanized steel and subject to moderate corrosion stress. Contains no copper, PTFE, or silicone.

Technical Specifications - Kinetix VPAR and MPAR Electric Cylinder Rod Guides

Rod guides protect ISO standard cylinders from torsion when subjected to radial or torsional side loads. They provide high-precision guidance for workpiece handling and other handling applications.

Rod Guides for Fixed Strokes

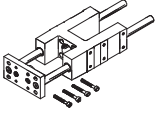
Rod Guide	Cat. No. Frame 32	Stroke mm (in.)	Cat. No. Frame 40	Stroke mm (in.)	Cat. No. Frame 63	Stroke mm (in.)
	MPAR-NE34494	10...100 (0.39...3.94)	MPAR-NE34500	10...100 (0.39...3.94)	MPAR-NE34514	10...100 (0.39...3.94)
	MPAR-NE34496	10...200 (0.39...7.87)	MPAR-NE34502	10...200 (0.39...7.87)	MPAR-NE34516	10...200 (0.39...7.87)
	MPAR-NE34497	10...320 (0.39...12.60)	MPAR-NE34504	10...320 (0.39...12.60)	MPAR-NE34518	10...320 (0.39...12.60)
	MPAR-NE150290	10...400 (0.39...15.75)	MPAR-NE150291	10...400 (0.39...15.75)	MPAR-NE34519	10...400 (0.39...15.75)
			MPAR-NE34505	10...500 (0.39...19.68)	MPAR-NE34520	10...500 (0.39...19.68)

Material Specifications

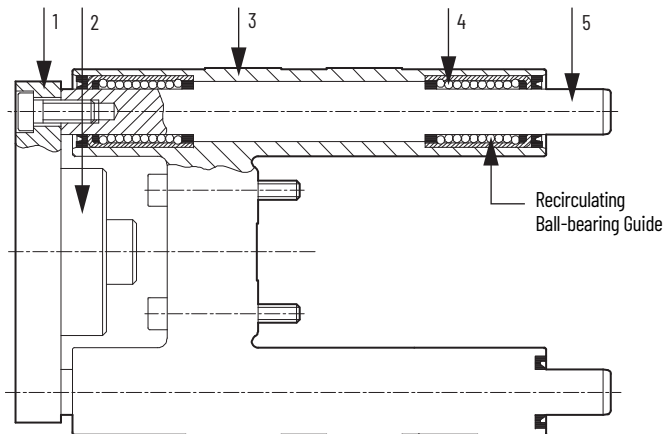

Item	Attribute	Value ⁽¹⁾
1	Yoke Plate	Aluminium
2	Coupling	Steel
3	Guide	Aluminium
4	Bearing	Steel
5	Guide Rods	Steel

(1) Contains no copper, PTFE, or silicone.

Maximum Working Load (F) as a Function of Cantilever Extension A

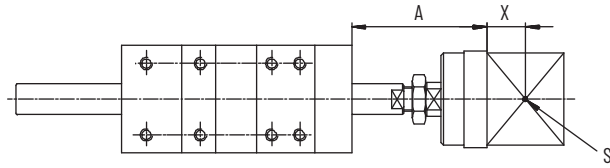

A = Cantilever Extension
 X = Distance for Center of Gravity of Working Load
 S = Center of Gravity of Working Load

Maximum Load Forces (frame 32)

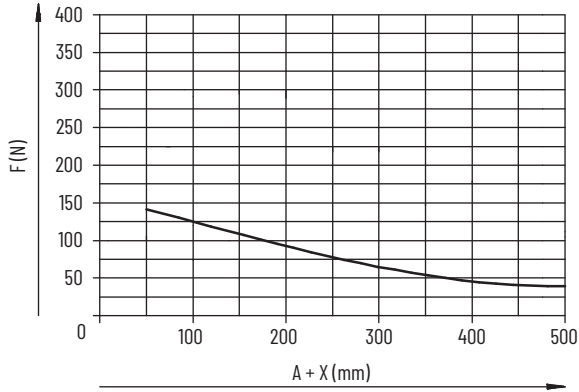

Maximum Load Forces (frame 40)

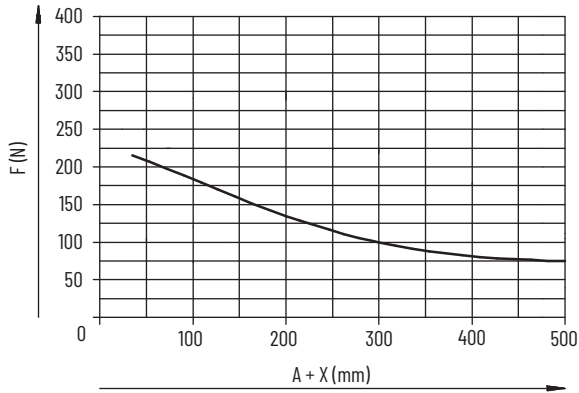

Maximum Load Forces (frame 63)

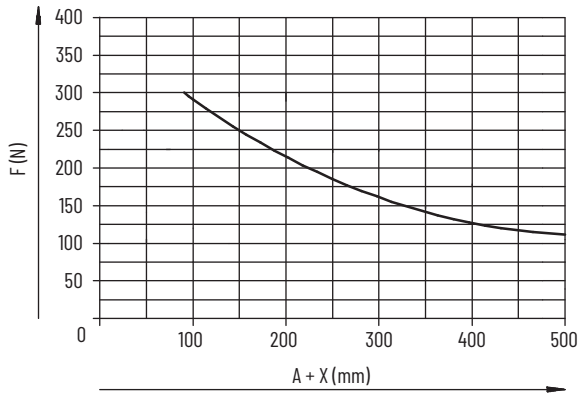

Rod Guide Dimensions

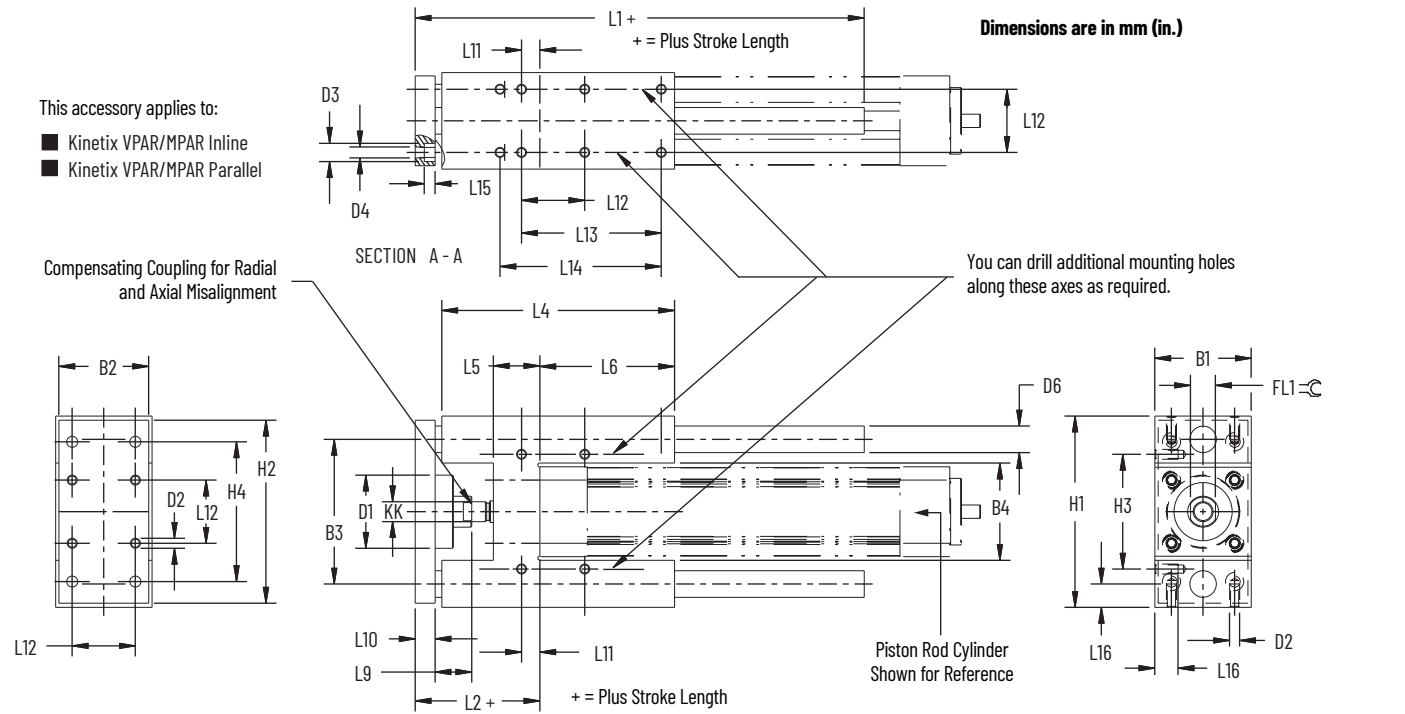

Frame	B1 (1) mm (in.)	B2 mm (in.)	B3 (2) mm (in.)	B4 (3) mm (in.)	D1 mm (in.)	D2	D3 mm (in.)	D4 mm (in.)	D6 mm (in.) h6	H1 mm (in.)	H2 mm (in.)	H3 (2) mm (in.)	H4 (2) mm (in.)	KK
32	50.0 (1.97)	45.0 (1.77)	74.0 (2.91)	50.5 (1.99)	44.0 (1.73)	M6	11.0 (0.43)	6.6 (0.26)	12.0 (0.47)	97.0 (4) (3.82)	90.0 (3.54)	61.0 (2.40)	78.0 (3.07)	M10x1.25
40	58.0 (2.28)	54.0 (2.13)	87.0 (3.43)	58.5 (2.30)	44.0 (1.73)	M6	11.0 (0.43)	6.6 (0.26)	16.0 (0.63)	115 (4) (4.53)	110 (4.33)	69.0 (2.72)	84.0 (3.31)	M12x1.25
63	85.0 (3.35)	80.0 (3.15)	119 (4.69)	85.5 (3.37)	60.0 (2.36)	M8	15.0 (0.59)	9.0 (0.35)	20.0 (0.79)	152 (5) (5.98)	145 (5.71)	100 (3.94)	105 (4.13)	M16x1.50

- (1) Tolerance for this dimension is -0.3 mm (-0.012 in.).
- (2) Tolerance for this dimension is ±0.2 mm (±0.008 in.).
- (3) Tolerance for this dimension is ±0.3 mm (±0.012 in.).
- (4) Tolerance for this dimension is -0.4 mm (-0.016 in.).
- (5) Tolerance for this dimension is -0.5 mm (-0.019 in.).

Frame	L1 mm (in.)	L2 mm (in.)	L4 mm (in.)	L5 mm (in.)	L6 mm (in.)	L9 mm (in.)	L10 mm (in.)	L11 mm (in.)	L12 (1) mm (in.)	L13 (1) mm (in.)	L14 (1) mm (in.)	L15 mm (in.)	L16 mm (in.)	FL1 mm C
32	155 (6.10)	67.0 (2) (2.64)	125 (4.92)	24.0 (0.94)	76.0 (2.99)	20.0 (0.79)	12.0 (0.47)	4.3 (0.17)	32.5 (1.28)	70.3 (2.77)	78.0 (3.07)	6.5 (0.26)	12.0 (0.47)	15
40	170 (6.69)	75.0 (2) (2.95)	140 (5.51)	28.0 (1.10)	81.0 (3.19)	22.0 (0.87)	12.0 (0.47)	11.0 (0.43)	38.0 (1.50)	84.0 (3.31)	-	6.5 (0.26)	14.0 (0.55)	15
63	220 (8.66)	89.0 (3) (3.50)	182 (7.17)	34.0 (1.34)	111 (4.37)	25.0 (0.98)	15.0 (0.59)	15.3 (0.60)	56.5 (2.22)	105 (4.13)	-	9.0 (0.35)	16.0 (0.63)	19

- (1) Tolerance for this dimension is ±0.2 mm (±0.008 in.).
- (2) Tolerance for this dimension is +5.0 mm (+0.197 in.).
- (3) Tolerance for this dimension is +10.0 mm (+0.394 in.).

Kinetix MPAI Heavy-duty Electric Cylinders



The Kinetix MPAI electric cylinders are compact, lightweight, high-force actuators that serve as a cost-effective alternative to fluid power solutions. These ready-to-install electric cylinders are energy efficient and provide machine flexibility, including precise, multi-point (positioning or force) motion profiles, that you can customize for movements with smooth startup and soft stops.

Kinetix MPAI Electric Cylinder Features

- Fully integrated servo motor and mechanics, these ready to install cylinders contribute to reductions in mechanical design engineering, assembly, wiring, and commissioning time.
- Standard and food-grade paint configurations are available in 64, 83, 110, and 144 mm frames sizes.
- State-of-the-art design features ballscrew or roller screw construction with linear stroke lengths up to 450 mm (18 in.), absolute high-resolution feedback, and speeds up to 610 mm/s (24 in/s).
- Lower operating costs... energy efficient actuators for 200V and 400V-class motion control systems.
- Extend and retract accurately. End with a soft touch.
- Linear feed force of up to 14,679 N (3300 lb).
- Sizing and engineering with compatible servo drives is made easy with Motion Analyzer software and online CAD files.
- Commissioning is simplified by the use of standard Allen-Bradley motor power and feedback cables.
- Full set-up and programming support by using Allen-Bradley Logix 5000 controllers. Studio 5000 Logix Designer and Ultraware software make setup and commissioning fast and easy.
- Closed loop control (absolute encoder feedback, standard).
- IP67 environmental rating (in static condition only).

Food Grade Paint Option Features

- Stainless steel actuator rod with Viton seals.
- Smooth body design with durable two-part (white) food-grade epoxy coating and corrosion resistant stainless steel fasteners.
- Fully encapsulated windings for moisture protection and increased thermal efficiency.
- Designed to meet the needs of many food, beverage, and medical requirements, with mounting below the food line.
- Two standard mounting options:
 - Front face mount: All surfaces epoxy coated, except for machined aluminum face-mounting surface used for direct mounting or with an optional stainless-steel front flange. Face mounted surface with type 316 stainless-steel wiper seal retaining rings are designed to eliminate pockets that can accumulate residue.
 - Rear clevis mount: All surfaces are epoxy coated including clevis mount attachment that has stainless steel inserts for the pivot and wear points.
- Field replaceable front wiper (Viton) seal.



**Kinetix MPAI (Food-grade paint)
Heavy-duty Electric Cylinder**

Catalog Numbers - Kinetix MPAI Electric Cylinders

Catalog numbers consist of various characters, each of which identifies a specific option for that component. Use the catalog numbering table chart below to understand the configuration of your actuator. For questions regarding product availability, contact your Allen-Bradley distributor.

Kinetix MPAI Electric Cylinders

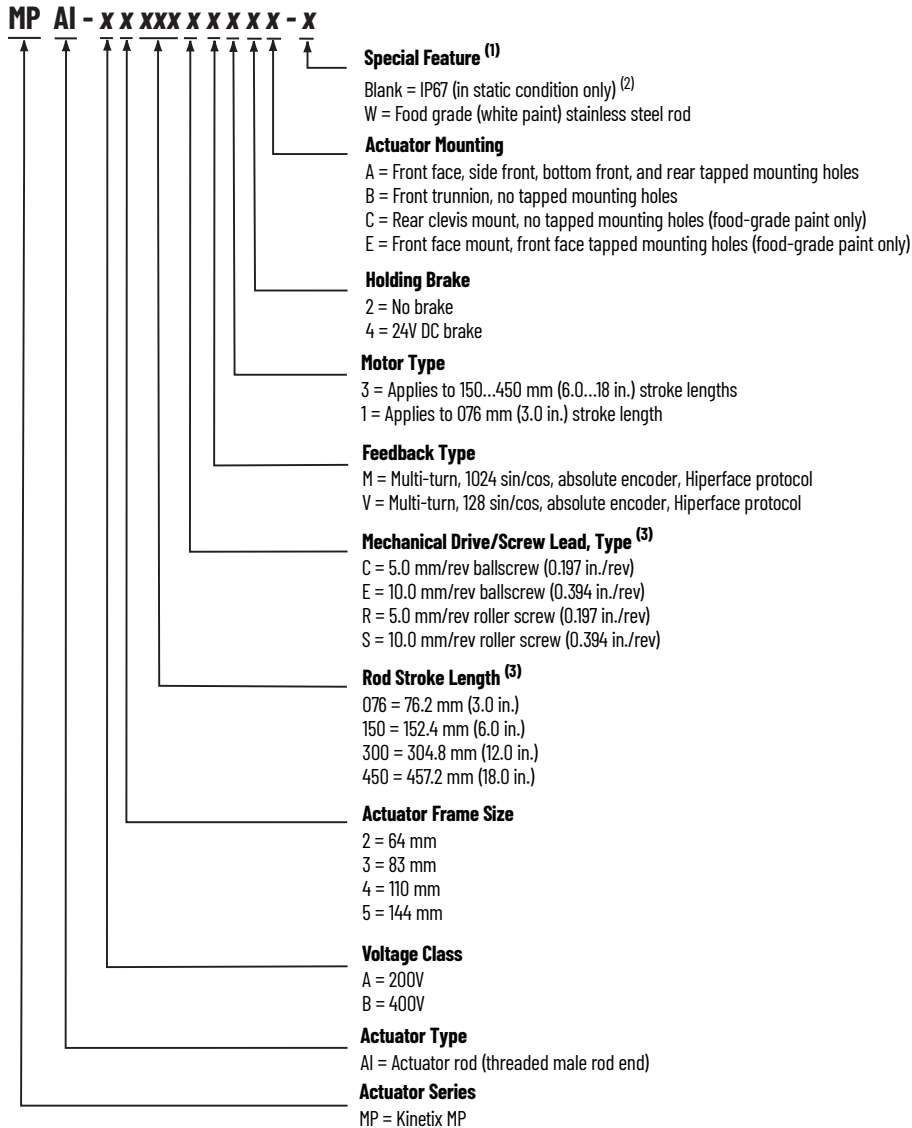

(1) The Special Feature field is used for customer-specific coding.

(2) Maintain the front bearing and wiper seal at the prescribed interval. Wipe rods dry before motion occurs or liquid could be drawn inside the actuator.

(3) Not all combinations are available. Only the configurations as listed in Performance Specifications (Standard, ballscrew), Performance Specifications (standard, roller screw), and Performance Specifications (Food-grade paint, ballscrew) beginning on [page 122](#), are available.

Kinetix MPAl Electric Cylinder Accessories

MP AI - xx x xx xx

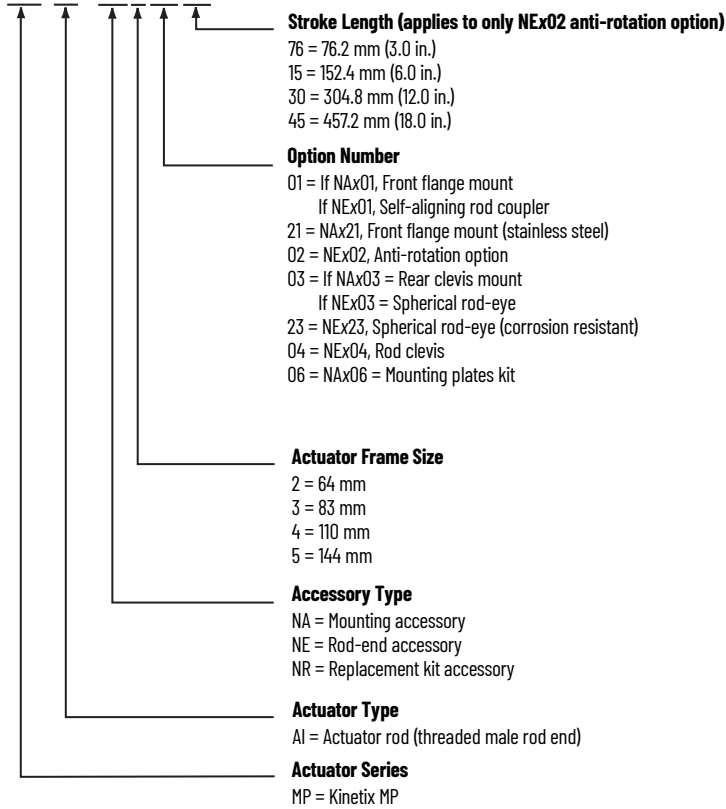

Motor Connector/Cable Compatibility

Kinetix MPAI Electric Cylinders

SpeedTec-ready DIN Connectors

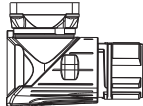

- MPAI-A/Bxxxx electric cylinders
- Receives M4 and M7 cable plugs (O-ring required for M4)
- Attach M7 cable plug with 1/8 to 1/4 turn

SpeedTec DIN (M7) Cable Plug

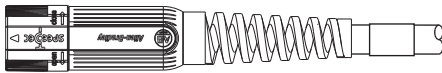

- 2090-CFBM7DF-CEAAxx (standard, non-flex) flying-lead, feedback cables
- 2090-CFBM7DD-CEAAxx (standard, non-flex) drive-end connector, feedback cables
- 2090-CFBM7DF-CEAFxx (continuous-flex) flying-lead, feedback cables
- 2090-CFBM7DD-CEAFxx (continuous-flex) drive-end connector, feedback cables
- 2090-CPWM7DF-xxAAxx (standard, non-flex) power-only cables
- 2090-CPBM7DF-xxAAxx (standard, non-flex) power/brake cables
- 2090-CPWM7DF-xxAFxx (continuous-flex) power-only cables
- 2090-CPBM7DF-xxAFxx (continuous-flex) power/brake cables

MPAI-A/B2xxx, MPAI-A/B3xxx, MPAI-A/B4xxx, and MPAI-B5xxx electric cylinders require 16 AWG power cables. MPAI-A5xxx electric cylinders require 14 AWG power cables.

Kinetix MPAI Electric Cylinder Accessories and Options

- 24V DC holding brake.
- Rod-end attachments, mounting attachments, and anti-rotation accessories.
- Positive Air Pressure kit (catalog number MPF-7-AIR-PURGE) is mounted on the feedback connector to provide positive air pressure to further reduce the chance of contamination inside the electric cylinder.

Refer to the Kinetix MPAI Heavy-duty Electric Cylinders Installation Instructions, publication [MPAI-IN001](#), for more information on the positive air pressure kit.

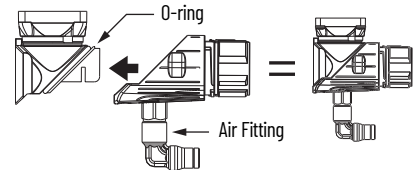

Kinetix MPAI Electric Cylinder Configurations

The Kinetix MPAI electric cylinders are available in standard and food-grade paint configurations. Both configurations are available in two mounting options and can be accessorized in the field with various mounting attachments.

Standard Configurations

- The front-face mount and front trunnion mount cylinders provide tapped holes for mounting attachments.
- The front trunnion mount cylinders are compatible with only the rod-end attachments.
- On standard configurations, the rear-clevis mounting bracket is purchased separately and field-installed.

Food Grade Paint Configurations

- Food-grade paint configurations are factory pre-assembled and epoxy painted.
- Pre-assembly and epoxy (white) paint is essential for the overall environmental integrity of the unit.
- No unnecessary accessory mounting holes are included.
- On food-grade paint configurations, the rear-clevis mounting bracket is pre-assembled and the cylinder is epoxy painted as a single unit.

Configurations and Accessories

Mounting Attachments

Accessory Item	Description	Dimensions
1	Mounting plates	page 134
2	Rear clevis mounting kit	page 135
3	Front flange mount	page 135
4	Anti-rotation option	page 137

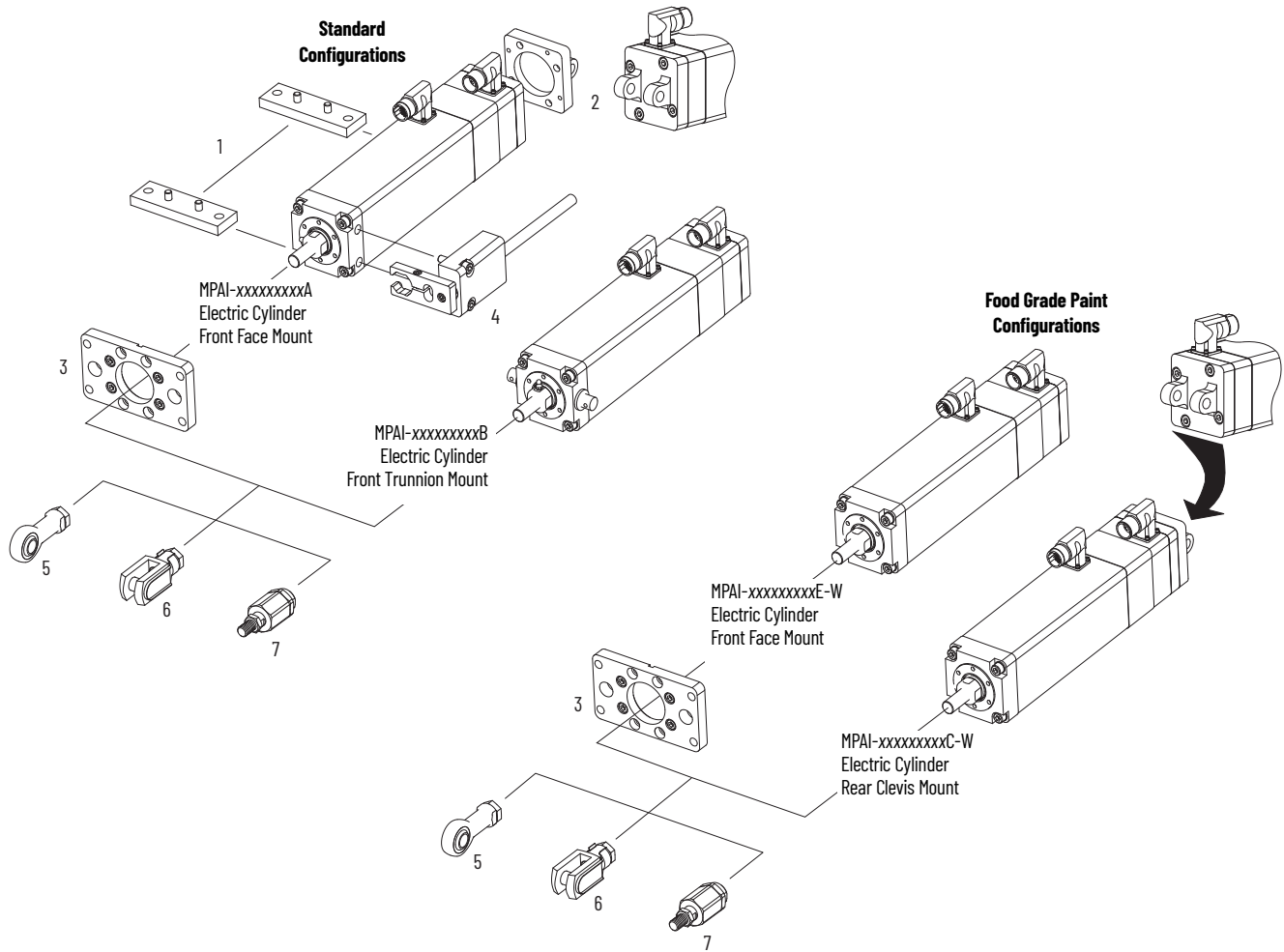

Rod-end Attachments

Accessory Item	Description	Dimensions
5	Rod eye	page 138
6	Rod clevis	page 139
7	Self-aligning rod coupler	page 139

Kinetix MPAI Electric Cylinders Life Specifications

Electric cylinder life specifications (total running performance) are based on a combination of tested and calculated data. If the parameters of your application are different, your results can be different. The achievable running performance, expressed as L, is a function of mean feed force F, according to DIN 69051-4 as illustrated below. Refer to Motion Analyzer software, version 4.800 or later, for assistance when making these calculations for determining the running performance for your application.

Ballscrew Expected Life Specifications

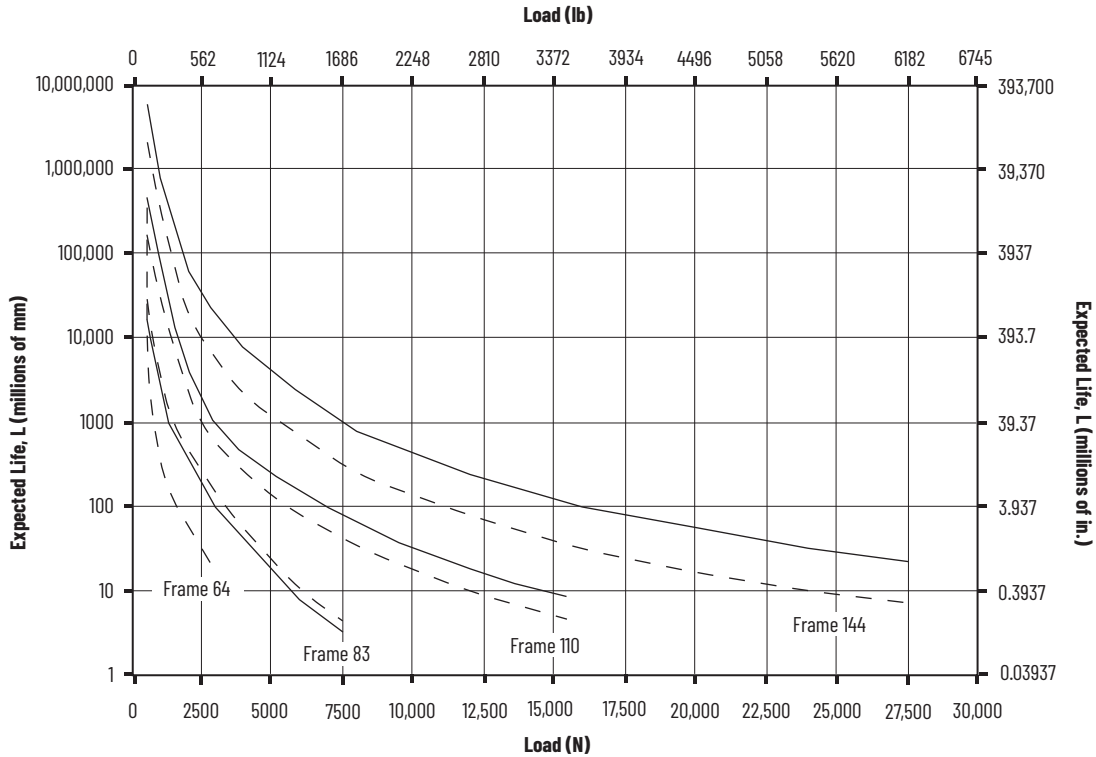

Load = Mean cubic feed force.
 Life, L = Accumulated total travel running performance.
 All curves represent properly lubricated and maintained actuators.

The L_{10} expected life of a ball-screw linear actuator is expressed as the linear travel distance that 90% of properly maintained ball-screws are expected to meet or exceed. This is not a guarantee. Use this graph for estimation purposes only.

Legend	
—	10 mm Lead
- - -	5 mm Lead

The underlying formula that defines this value is:

$$L_{10} = \left(P \right) \left(\frac{C}{F} \right)^3$$

Where:
 L_{10} = Travel life in m (in.)
 C = Dynamic load rating N (lb)
 F = Cubic mean applied load N (lb)
 P = Screw lead mm (in.)

Roller Screw Expected Life Specifications

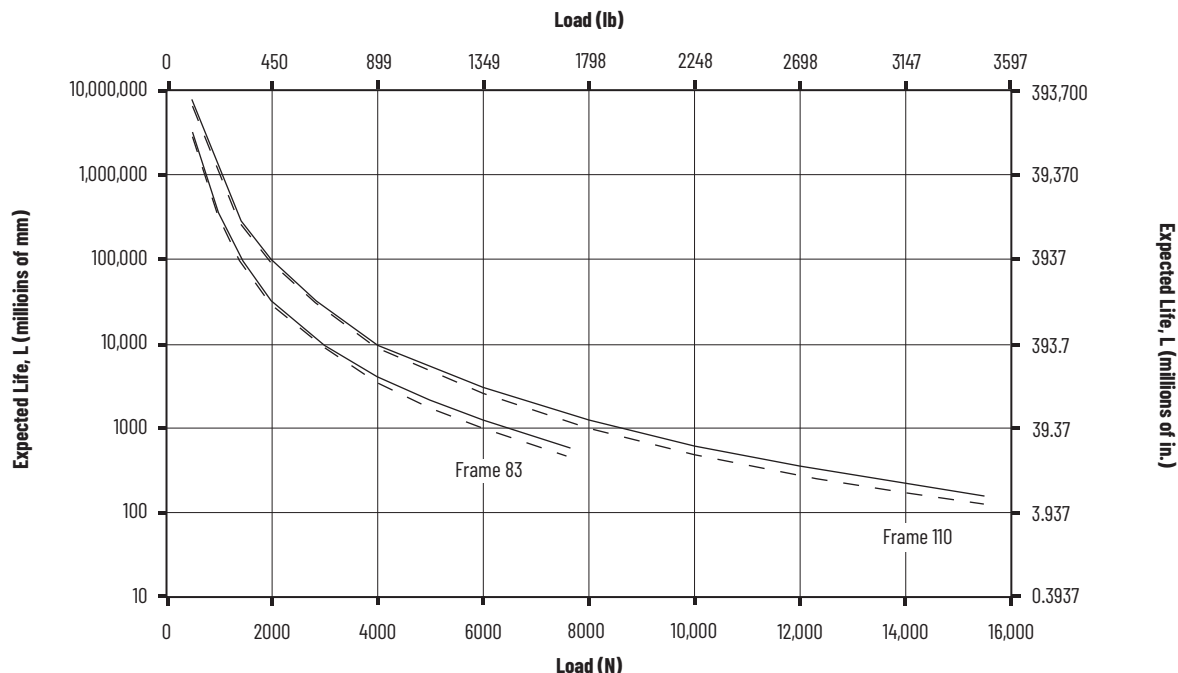

Load = Mean cubic feed force.
 Life, L = Accumulated total travel running performance.
 All curves represent properly lubricated and maintained actuators.

The L_{10} expected life of a roller-screw linear actuator is expressed as the linear travel distance that 90% of properly maintained roller-screws are expected to meet or exceed. This is not a guarantee. Use this graph for estimation purposes only.

Legend	
—	10 mm Lead
- - -	5 mm Lead

The underlying formula that defines this value is:

$$L_{10} = \left(P \right) \left(\frac{C}{F} \right)^3$$

Where:
 L_{10} = Travel life in millions of mm (in.)
 C = Dynamic load rating N (lb)
 F = Cubic mean applied load N (lb)
 P = Screw lead mm (in.)

Application Guidelines

All Loads must be separately supported and guided ^(a). Align loads along the line-of-thrust rod motion. Side loading affects the life of the actuator. Actuators have been lubricated at the factory and are ready for installation. For moderate to light use, no lubrication is required for the life of the actuator. For more severe duty use (higher loads and/or higher duty cycles), periodic lubrication is necessary to achieve actuator expected life ^(b). Add grease via the built-in grease fitting. Removing the cylinder from the machine is seldom necessary ^(c).

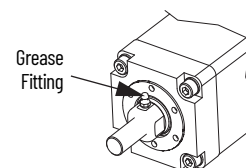

(a) Kinetix MPAL actuators are not meant for use where side loading occurs. This is a common application characteristic shared by fluid power cylinders.
 (b) Refer to the Kinetix MPAL Heavy-duty Electric Cylinders Installation Instructions, publication [MPAL-IN001](#), for lubrication guidelines and specifications.
 (c) You can extend or retract the rod to a point where the grease fitting (if present) is more accessible.

Technical Specifications - Kinetix MPAI Electric Cylinders

General Specifications

Attribute	Frame 64	Frame 83	Frame 110	Frame 144
Construction design	Ballscrew servo-driven actuator	Ballscrew or roller screw servo-driven actuator		Ballscrew servo-driven actuator
Piston rod thread	M10 x 1.25	M16 x 1.50	M20 x 1.50	M27 x 2.00
Working stroke length	76.2 mm (3.0 in.) 152.4 mm (6.0 in.) 304.8 mm (12.0 in.)	76.2 mm (3.0 in.) 152.4 mm (6.0 in.) 304.8 mm (12.0 in.) 457.2 mm (18.0 in.)	152.4 mm (6.0 in.) 304.8 mm (12.0 in.) 457.2 mm (18.0 in.)	
Protection against torsion/guide	Plain bearing guide			
Stroke reserve	0 mm			
Positioning repeatability, max	±0.02 mm (0.0008 in.)			
Reversing backlash, max ⁽¹⁾				
Ballscrew	0.10 mm (0.004 in.)	0.10 mm (0.004 in.)	0.13 mm (0.005 in.)	0.13 mm (0.005 in.)
Roller screw	-	0.03 mm (0.001 in.)	0.03 mm (0.001 in.)	-
Duty cycle	100%			
Position sensing (feedback)	Multi-turn absolute encoder			
Mounting position	Any			

(1) In new condition.

Materials Specifications

Attribute	Standard Configuration Cat. No. MPAI-xxxxxxxxxA or MPAI-xxxxxxxxxB	Food Grade Paint Configuration Cat. No. MPAI-xxxxxxxxxE-W or MPAI-xxxxxxxxxC-W
Chassis body/finish	Black anodized extruded aluminum	White painted anodized aluminum
Assembly hardware	Standard hardened steel	304 or 316 stainless steel
Rod end	Zinc plated steel alloy	304 or 316 stainless steel
Rod	Salt bath nitride treated steel Hardness = 65 HRC Thickness = 0.0004...0.0008 in.	304 or 316 stainless steel
Rod wiper seal	Nitrile/standard grease	Viton
Body seals	Nitrile	Viton
Front bearing block	Machined anodized aluminum	Machined (not casted) aluminum on front face mounting surface
Wiper seal cover	316 stainless steel	316 stainless steel
Zerk fitting ⁽¹⁾	Steel	Stainless steel
Mounting hole	Stainless steel inserts 18...8 (304)	
Connectors	Zinc die cast, blue chromated plate	Zinc die cast, blue chromated plate with epoxy paint (same as Kinetix MPF motors)
Label	Same as used on Kinetix MPL motors	
Environmental rating	IP66/67	

(1) Zerk fitting not present on MPAI-x2xxx (64 frame) electric cylinders.

Performance Specifications (Standard, ballscrew)

Electric Cylinder (1) Cat. No.	Frame	Peak Feed Force N (lb)	System Continuous (2) Stall Force N (lb)		Speed, max mm/s (in/s)	Ballscrew Lead mm/rev (in./rev)	Stroke Lengths mm (in.)	Dynamic Load Rating (1 million revs) N (lb)	
			25 °C (77 °F)	40 °C (104 °F)					
MPAI-x2076CV1xx	64	1446 (325)	890 (200)	706 (159)	305 (12)	5.0 (0.197)	76.2 (3.0)	4502 (1012)	
MPAI-x2150CV3xx			1446 (325)	1147 (258)			152.4 (6.0)		
MPAI-x2300CV3xx			1446 (325)	1147 (258)			304.8 (12.0)		
MPAI-x3076CM1xx (3)	83	5140 (1155)	1624 (365)	1290 (290)	305 (12)	5.0 (0.197)	76.2 (3.0) (4)	7602 (1709)	
MPAI-x3150CM3xx		4448 (1000)	4003 (900)	3176 (714)	279 (11)		152.4 (6.0)		
MPAI-x3300CM3xx					188 (7.3)		304.8 (12.0)		
MPAI-x3450CM3xx					188 (7.3)	457.2 (18.0)			
MPAI-x3076EM1xx (3)		2570 (578)	814 (183)	645 (145)	610 (24)	10.0 (0.394)	76.2 (3.0) (4)		5400 (1214)
MPAI-x3150EM3xx		4003 (900)	2002 (450)	1588 (357)	559 (22)		152.4 (6.0)		
MPAI-x3300EM3xx	376 (15)				304.8 (12.0)				
MPAI-x3450EM3xx	376 (15)				457.2 (18.0)				
MPAI-x4150CM3xx	110	8896 (2000)	7784 (1750)	6179 (1389)	279 (11)	5.0 (0.197)	152.4 (6.0)	15,100 (3395)	
MPAI-x4300CM3xx					245 (9.5)		304.8 (12.0)		
MPAI-x4450CM3xx					245 (9.5)		457.2 (18.0)		
MPAI-x4150EM3xx		7784 (1750)	3892 (875)	3092 (695)	559 (22)	10.0 (0.394)	152.4 (6.0)		15,000 (3372)
MPAI-x4300EM3xx					491 (19)		304.8 (12.0)		
MPAI-x4450EM3xx					491 (19)		457.2 (18.0)		
MPAI-x5150CM3xx	144	13,345 (3000)	13,122 (2950)	10,415 (2341)	200 (7.9)	5.0 (0.197)	152.4 (6.0)	28,865 (6714)	
MPAI-x5300CM3xx					200 (7.9)		304.8 (12.0)		
MPAI-x5450CM3xx					200 (7.9)		457.2 (18.0)		
MPAI-x5150EM3xx		13,122 (2950)	6561 (1475)	5208 (1171)	400 (15.7)	10.0 (0.394)	152.4 (6.0)		35,255 (7476)
MPAI-x5300EM3xx					400 (15.7)		304.8 (12.0)		
MPAI-x5450EM3xx					400 (15.7)		457.2 (18.0)		

(1) MPAI-A (200V-class) or MPAI-B (400V-class) replaces x in catalog number.
 (2) Characteristics when mounted to 279 x 279 x 12.7 mm (11 x 11 x 0.5 in.) aluminum mounting surface.
 (3) Duty cycle for peak feed force is 1.0 second on and at least 15.0 seconds off.
 (4) This stroke length is available in only 64 and 83 frame sizes.

Performance Specifications (standard, roller screw)

Electric Cylinder (1) Cat. No.	Frame	Peak Feed Force N (lb)	System Continuous (2) Stall Force N (lb)		Speed, max mm/s (in/s)	Roller Screw Lead mm/rev	Stroke Lengths mm (in.)	Dynamic Load Rating (1 million revs) N (lb)	
			25 °C (77 °F)	40 °C (104 °F)					
MPAI-x3076RM1xx (3)	83	4862 (1093)	1557 (350)	1237 (278)	305 (12)	5.0 (0.197)	76.2 mm (3.0 in.) (4)	35,030 (7875)	
MPAI-x3150RM3xx					279 (11)		152.4 mm (6.0 in.)		
MPAI-x3300RM3xx					176 (6.9)		304.8 mm (12.0 in.)		
MPAI-x3450RM3xx		176 (6.9)	457.2 mm (18.0 in.)						
MPAI-x3076SM1xx (3)		2431 (547)	778 (175)	618 (139)	610 (24)	10.0 (0.394)	76.2 mm (3.0 in.) (4)		30,270 (6805)
MPAI-x3150SM3xx		3781 (850)	1891 (425)	1499 (337)	559 (22)		152.4 mm (6.0 in.)		
MPAI-x3300SM3xx	353 (14)				304.8 mm (12.0 in.)				
MPAI-x3450SM3xx	353 (14)				457.2 mm (18.0 in.)				
MPAI-x4150RM3xx	110	14,679 (3300)	7340 (1650)	5827 (1310)	279 (11)	5.0 (0.197)	152.4 mm (6.0 in.)	47,520 (10,683)	
MPAI-x4300RM3xx					196 (7.6)		304.8 mm (12.0 in.)		
MPAI-x4450RM3xx					196 (7.6)		457.2 mm (18.0 in.)		
MPAI-x4150SM3xx		7340 (1650)	3670 (825)	2914 (655)	559 (22)	10.0 (0.394)	152.4 mm (6.0 in.)		40,968 (9210)
MPAI-x4300SM3xx					393 (15)		304.8 mm (12.0 in.)		
MPAI-x4450SM3xx					393 (15)		457.2 mm (18.0 in.)		

(1) MPAI-A (200V-class) or MPAI-B (400V-class) replaces x in catalog number.
 (2) Characteristics when mounted to 279 x 279 x 12.7 mm (11 x 11 x 0.5 in.) aluminum mounting surface.
 (3) Duty cycle for peak feed force is 1.0 second on and at least 15.0 seconds off.
 (4) This stroke length is available in only the 83 mm frame size.

Performance Specifications (Food-grade paint, ballscrew)

Electric Cylinder (1) Cat. No.	Frame	Peak Feed Force N (lb)	System Continuous (2) Stall Force N (lb)		Speed, max mm/s (in/s)	Ballscrew Lead mm/rev (in./rev)	Stroke Lengths mm (in.)	Dynamic Load Rating (1 million revs) N (lb)			
			25 °C (77 °F)	40 °C (104 °F)							
MPAI-x2076CV1xx-W	64	1446 (325)	890 (200)	706 (159)	305 (12)	5.0 (0.197)	76.2 (3.0)	4502 (1012)			
MPAI-x2150CV3xx-W			1446 (325)	1147 (258)			152.4 (6.0)				
MPAI-x2300CV3xx-W							304.8 (12.0)				
MPAI-x3076CM1xx-W (3)	83	5140 (1155)	1624 (365)	1290 (290)	305 (12)	5.0 (0.197)	76.2 (3.0) (4)	7602 (1709)			
MPAI-x3150CM3xx-W		4448 (1000)	4003 (900)	3176 (714)	279 (11)		152.4 (6.0)				
MPAI-x3300CM3xx-W					188 (7.3)		304.8 (12.0)				
MPAI-x3450CM3xx-W							457.2 (18.0)				
MPAI-x3076EM1xx-W (3)		83	2570 (578)	814 (183)	645 (145)		610 (24)		10.0 (0.394)	76.2 (3.0) (4)	5400 (1214)
MPAI-x3150EM3xx-W			4003 (900)	2002 (450)	1588 (357)		559 (22)			152.4 (6.0)	
MPAI-x3300EM3xx-W	376 (15)					304.8 (12.0)					
MPAI-x3450EM3xx-W						457.2 (18.0)					
MPAI-x4150CM3xx-W	110	8896 (2000)	7784 (1750)	6179 (1389)	279 (11)	5.0 (0.197)	152.4 (6.0)	15,100 (3395)			
MPAI-x4300CM3xx-W									245 (9.5)	304.8 (12.0)	
MPAI-x4450CM3xx-W										457.2 (18.0)	
MPAI-x4150EM3xx-W		7784 (1750)	3892 (875)	3092 (695)	559 (22)	10.0 (0.394)	152.4 (6.0)	15,000 (3372)			
MPAI-x4300EM3xx-W					491 (19)		304.8 (12.0)				
MPAI-x4450EM3xx-W							457.2 (18.0)				
MPAI-x5150CM3xx-W	144	13,345 (3000)	13,122 (2950)	10,415 (2341)	200 (79)	5.0 (0.197)	152.4 (6.0)	28,865 (6714)			
MPAI-x5300CM3xx-W										304.8 (12.0)	
MPAI-x5450CM3xx-W										457.2 (18.0)	
MPAI-x5150EM3xx-W		13,122 (2950)	6561 (1475)	5208 (1171)	400 (15.7)	10.0 (0.394)	152.4 (6.0)	35,255 (7476)			
MPAI-x5300EM3xx-W										304.8 (12.0)	
MPAI-x5450EM3xx-W										457.2 (18.0)	

(1) MPAI-A (200V-class) or MPAI-B (400V-class) replaces x in catalog number.
 (2) Characteristics when mounted to 279 x 279 x 12.7 mm (11 x 11 x 0.5 in.) aluminum mounting surface.
 (3) Duty cycle for peak feed force is 1.0 second on and at least 15.0 seconds off.
 (4) This stroke length is available in only 64 and 83 frame sizes.

Kinetix MPAI Electric Cylinder Motor Brake Specifications

Electric Cylinder Cat. No.	Static Torque N·m (lb·in)	Coil Current at 24V DC A _{peak}	Brake Response Time		
			Release ms	Engage (by using external arc suppression device)	
				MOV ms	Diode ms
MPAI-x2xxxxVx4x	1.6 (14.0)	0.35	20	75	150
MPAI-x3xxxxMx4x	4.0 (35.4)	0.43	50	40	80
MPAI-x4xxxxMx4x	10.0 (88.5)	0.67	35	25	50
MPAI-x5xxxxMx4x	16.4 (145)	0.66	25	15	30

Estimated Brake Holding Force

Electric Cylinder Cat. No.	MPAI-xxxxCVx4x (1) MPAI-xxxxCMx4x N (lb)	MPAI-xxxxEMx4x (1) N (lb)	MPAI-xxxxRMx4x (2) N (lb)	MPAI-xxxxSMx4x (2) N (lb)
MPAI-x2xxxxVx4x	2300 (517)	-	-	-
MPAI-x3xxxxMx4x	5818 (1308)	2909 (654)	6423 (1444)	3212 (722)
MPAI-x4xxxxMx4x	14,550 (3271)	7272 (1635)	16,063 (3611)	8029 (1805)
MPAI-x5xxxxMx4x	23,838 (5359)	11,921 (2680)	-	-

(1) MPAI-xxxxCMx4x is a 5 mm ball-screw actuator and MPAI-xxxxEMx4x is a 10 mm ball-screw actuator.
 (2) MPAI-xxxxRMx4x is a 5 mm roller-screw actuator and MPAI-xxxxSMx4x is a 10 mm roller-screw actuator.

In vertical applications, an unpowered Kinetix MPAl electric cylinder requires a holding brake to maintain position if the load on the actuator exceeds these values.

Back Drive Force

Electric Cylinder Cat. No.	MPAl-xxxxCVxxx MPAl-xxxxCMxxx N (lb)	MPAl-xxxxEMxxx N (lb)	MPAl-xxxxRMxxx N (lb)	MPAl-xxxxSMxxx N (lb)
MPAl-x2xxxxVxxx	218 (49)	-	-	-
MPAl-x3xxxxMxxx	267 (60)	126 (28)	592 (133)	525 (118)
MPAl-x4xxxxMxxx	445 (100)	196 (44)	734 (165)	623 (140)
MPAl-x5xxxxMxxx	667 (153)	343 (77)	-	-

Weight Specifications

Standard Mount and Trunnion Mount Electric Cylinders

Electric Cylinder (1) (Frame 64) Cat. No.	Weight, approx kg (lb)	Electric Cylinder (Frame 83) Cat. No.	Weight, approx kg (lb)	Electric Cylinder (Frame 110) Cat. No.	Weight, approx kg (lb)	Electric Cylinder (2) (Frame 144) Cat. No.	Weight, (3) (4) approx kg (lb)
MPAl-x2076xV12x	3.2 (7.1)	MPAl-x3076xM12x	7.0 (15.4)	-	-	-	-
MPAl-x2150xV12x	4.7 (10.4)	MPAl-x3150xM32x	8.3 (18.3)	MPAl-x4150xM32x	15.8 (34.8)	MPAl-x5150xM32A	32.1 (70.7)
MPAl-x2300xV12x	5.8 (12.8)	MPAl-x3300xM32x	10.1 (22.2)	MPAl-x4300xM32x	18.8 (41.4)	MPAl-x5300xM32A	37.8 (83.3)
-	-	MPAl-x3450xM32x	11.9 (26.2)	MPAl-x4450xM32x	21.8 (48.0)	MPAl-x5450xM32A	43.6 (96.1)
MPAl-x2076xV14x	3.7 (8.2)	MPAl-x3076xM14x	7.9 (17.4)	-	-	-	-
MPAl-x2150xV14x	5.2 (11.5)	MPAl-x3150xM34x	9.3 (20.5)	MPAl-x4150xM34x	17.3 (38.1)	MPAl-x5150xM34A	34.4 (75.8)
MPAl-x2300xV14x	6.3 (13.9)	MPAl-x3300xM34x	11.1 (24.4)	MPAl-x4300xM34x	20.3 (44.7)	MPAl-x5300xM34A	40.2 (88.6)
-	-	MPAl-x3450xM34x	12.9 (28.4)	MPAl-x4450xM34x	23.3 (51.4)	MPAl-x5450xM34A	45.9 (101.2)

- (1) For MPAl-x2xx xCVxxC-W (rear clevis mount) cylinders, add 0.2 kg (0.44 lb).
- (2) Includes MPAl-x5xxxxM3xA and MPAl-x5xxxxM3xE-W (front face mount) cylinders.
- (3) For MPAl-x5xxxxM3xB (front trunnion mount) cylinders, add 0.5 kg (1.1 lb).
- (4) For MPAl-x5xxxxM3xC-W (rear clevis mount) cylinders, add 2.1 kg (4.6 lb).

Mounting Accessories

Accessory	Frame	Cat. No.	Weight, approx g (oz)
Mounting plates	64	MPAl-NA206	500 (17.6)
	83	MPAl-NA306	920 (32.5)
	110	MPAl-NA406	1150 (40.6)
	144	MPAl-NA506	3080 (108.6)
Rear clevis mount	64	MPAl-NA203	310 (10.9)
	83	MPAl-NA303	700 (24.7)
	110	MPAl-NA403	1430 (50.4)
	144	MPAl-NA503	3010 (106.2)
Front flange mount	64	MPAl-NA201	490 (17.3)
	83	MPAl-NA301	1070 (37.7)
	110	MPAl-NA401	1740 (61.4)
	144	MPAl-NA501	4170 (147.1)
Front flange mount (stainless steel)	64	MPAl-NA221	500 (17.6)
	83	MPAl-NA321	1090 (38.4)
	110	MPAl-NA421	1770 (62.4)
	144	MPAl-NA521	4250 (149.9)

Rod-end Accessories

Accessory	Frame	Cat. No.	Weight, approx g (oz)
Rod eye	64	MPAI-NE203	90 (3.2)
	83	MPAI-NE303	255 (9.0)
	110	MPAI-NE403	497 (17.5)
	144	MPAI-NE503	1330 (46.9)
Rod eye (stainless steel)	64	MPAI-NE223	70 (2.5)
	83	MPAI-NE323	210 (7.4)
	110	MPAI-NE423	380 (13.4)
	144	MPAI-NE523	1300 (45.8)

Accessory	Frame	Cat. No.	Weight, approx g (oz)
Self-aligning rod coupler	64	MPAI-N201	220 (7.8)
	83	MPAI-NE301	660 (23.3)
	110	MPAI-NE401	730 (25.7)
	144	MPAI-NE501	2200 (77.6)
Rod clevis	64	MPAI-NE204	100 (3.53)
	83	MPAI-NE304	350 (12.3)
	110	MPAI-NE404	710 (25.0)
	144	MPAI-NE504	2030 (71.6)

Anti-rotation Option Accessories

Anti-rotation (Frame 64) Cat. No.	Weight, approx g (oz)
MPAI-NE20276	330 (11.6)
MPAI-NE20215	370 (13.1)
MPAI-NE20230	450 (15.9)
-	

Anti-rotation (Frame 83) Cat. No.	Weight, approx g (oz)
MPAI-NE30276	660 (23.3)
MPAI-NE30215	740 (26.1)
MPAI-NE30230	890 (31.4)
MPAI-NE30245	1040 (36.7)

Anti-rotation (Frame 110) Cat. No.	Weight, approx g (oz)
-	
MPAI-NE40215	820 (28.9)
MPAI-NE40230	980 (34.6)
MPAI-NE40245	1130 (39.8)

Anti-rotation (Frame 144) Cat. No.	Weight, approx g (oz)
-	
MPAI-NE50215	2330 (82.2)
MPAI-NE50230	2660 (93.8)
MPAI-NE50245	3000 (105.8)

Dimensions - Kinetix MPAI Electric Cylinders

Kinetix MPAI Electric Cylinder (face-mount standard) Dimensions (Frame 64, 83, 110, and 144) MPAL-xxxxxxxAA Face Mount (standard) Configuration

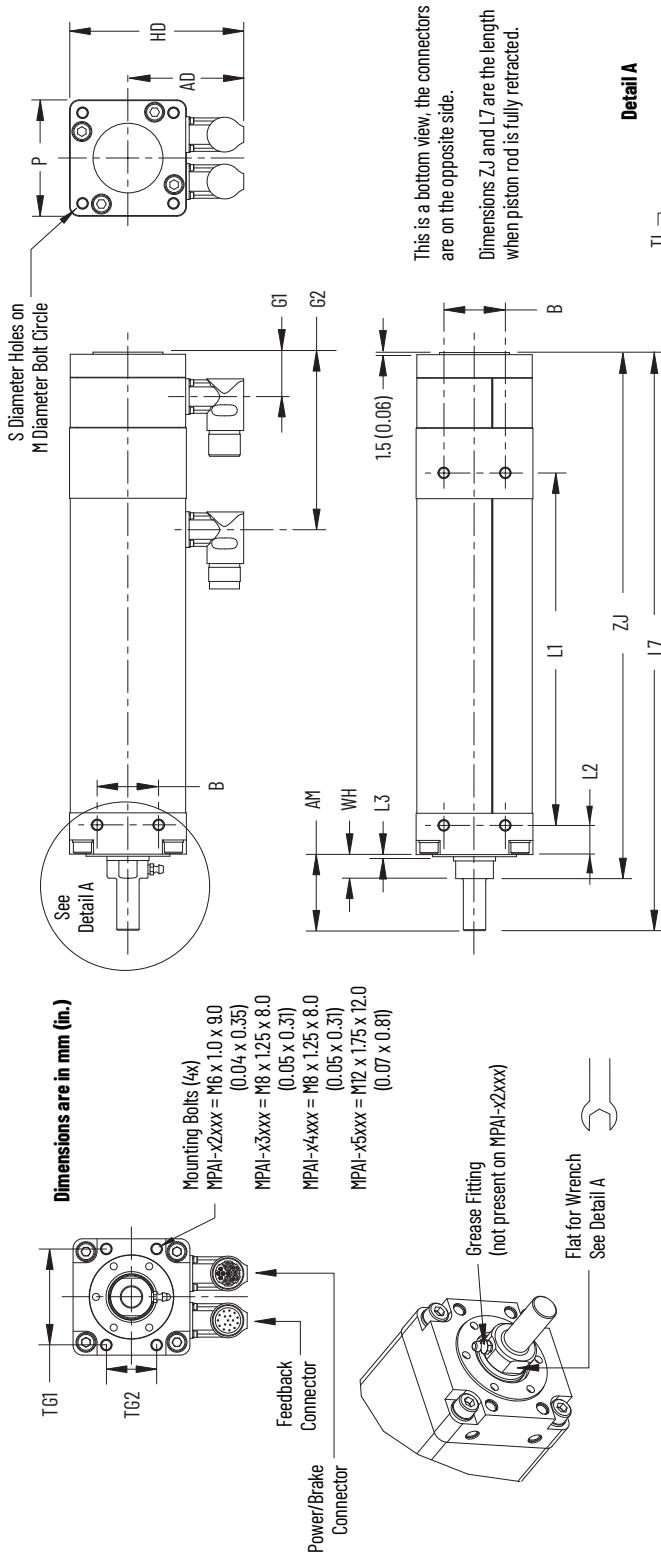

Detail A Dimensions

Frame Size	TL (threaded length, min) mm (in.)	PD (pilot diameter) mm (in.)	AF (across flats) mm (in.)	RD (rod diameter) mm (in.)
64	M10 x 1.25 x 22.1 (0.049 x 0.87)	Ø 47.955...48.000 (1.8880...1.8898)	22.74...22.99 (0.895...0.905)	Ø 25.38 (0.999)
83	M16 x 1.5 x 34.3 (0.06 x 1.35)	Ø 59.955...60.000 (2.3604...2.3622)	26.72...26.97 (1.052...1.062)	Ø 30.13 (1.186)
110	M20 x 1.5 x 41.4 (0.06 x 1.63)	Ø 71.955...72.000 (2.8328...2.8346)	34.73...34.98 (1.367...1.377)	Ø 38.08 (1.499)
144	M27 x 2.0 x 45.7 (0.08 x 1.80)	Ø 99.955...100.000 (3.9352...3.9370)	53.73...53.98 (2.115...2.125)	Ø 57.13 (2.249)

Kinetix MPAI Electric Cylinder (face-mount standard) Dimensions (Frame 64)

Electric Cylinder Cat. No.	AD mm (in.)	AM mm (in.)	B mm (in.)	G1 mm (in.)	G2 (1) mm (in.)	HD mm (in.)	L1 mm (in.)	L2 mm (in.)	L3 mm (in.)	L7 (1) mm (in.)	M (2) mm (in.)	P mm (in.)	S mm (in.)	TG1 mm (in.)	TG2 mm (in.)	WH mm (in.)	ZJ (1) mm (in.)
MPAL-A/B2076CV12A							144.0 (5.67)			288.1 (11.34)							263.5 (10.37)
MPAL-A/B2150CV32A	72.8 (2.87)	41.9 (1.65)	34.0 (1.34)	28.8 (1.13)	106.9 (4.21)	104.5 (4.11)	220.2 (8.67)	20.00 (0.787)	1.50 (0.06)	364.3 (14.34)	70.0 (2.76)	63.5 (2.50)	M6 x 1.0 x 9.0 (0.04 x 0.35)	54.0 (2.13)	20.0 (0.79)	17.3 (0.68)	339.7 (13.37)
MPAL-A/B2300CV32A							372.6 (14.67)			516.7 (20.34)							492.1 (19.37)

Kinetix MPAL Electric Cylinder (face-mount standard) Dimensions (Frame 83)

Electric Cylinder Cat. No.	AD	AM	B	G1	G2 (1)	HD	L1	L2	L3	L7 (1)	M (2)	P	S	TG1	TG2	WH	ZJ (1)
	mm (in.)	mm (in.)	mm (in.)	mm (in.)	mm (in.)	mm (in.)	mm (in.)	mm (in.)	mm (in.)	mm (in.)	mm (in.)	mm (in.)	mm (in.)	mm (in.)	mm (in.)	mm (in.)	mm (in.)
MPAL-A/B3076xM12A							177.0 (6.97)			337.6 (13.29)							300.0 (11.81)
MPAL-A/B3150xM32A	82.8 (3.26)	54.6 (2.15)	44.0 (1.73)	319 (1.25)	127.5 (5.02)	124.6 (4.90)	253.1 (9.97)	21.0 (0.83)	1.50 (0.06)	413.6 (16.29)	92.0 (3.622)	83.6 (3.29)	M8 x 1.25 x12 (0.05 x 0.47)	69.0 (2.72)	36.0 (1.42)	17.3 (0.68)	376.3 (14.81)
MPAL-A/B3300xM32A							405.5 (15.97)			566.0 (22.29)							528.7 (20.81)
MPAL-A/B3450xM32A							557.9 (21.97)			718.4 (28.29)							681.1 (26.81)

(1) If ordering MPAL-A/B3xxxxxM4A actuator with brake, add 47.7 mm (1.88 in.) to dimensions G2, L7, and ZJ.
 (2) The tolerance for this dimension is +0.0, -0.038 mm (+0.0, -0.0015 in.).

Kinetix MPAL Electric Cylinder (face-mount standard) Dimensions (Frame 110)

Electric Cylinder Cat. No.	AD	AM	B	G1	G2 (1)	HD	L1	L2	L3	L7 (1)	M (2)	P	S	TG1	TG2	WH	ZJ (1)
	mm (in.)	mm (in.)	mm (in.)	mm (in.)	mm (in.)	mm (in.)	mm (in.)	mm (in.)	mm (in.)	mm (in.)	mm (in.)	mm (in.)	mm (in.)	mm (in.)	mm (in.)	mm (in.)	mm (in.)
MPAL-A/B4150xM32A							295.4 (11.63)			466.6 (18.37)							422.1 (16.62)
MPAL-A/B4300xM32A	96.3 (3.79)	61.3 (2.41)	50.0 (1.97)	319 (1.25)	130.7 (5.15)	151.5 (5.96)	447.8 (17.63)	25.0 (0.98)	1.50 (0.06)	618.0 (24.37)	127.0 (5.0)	110.5 (4.35)	M8 x 1.25 x12 (0.05 x 0.47)	85.0 (3.35)	55.0 (2.17)	16.8 (0.66)	574.5 (22.62)
MPAL-A/B4450xM32A							600.2 (23.63)			771.4 (30.37)							726.9 (28.62)

(1) If ordering MPAL-A/B4xxxxxM4A actuator with brake, add 46.2 mm (1.81 in.) to dimensions G2, L7, and ZJ.
 (2) The tolerance for this dimension is +0.0, -0.038 mm (+0.0, -0.0015 in.).

Kinetix MPAL Electric Cylinder (face-mount standard) Dimensions (Frame 144)

Electric Cylinder Cat. No.	AD	AM	B	G1	G2 (1)	HD	L1	L2	L3	L7 (1)	M (2)	P	S	TG1	TG2	WH	ZJ (1)
	mm (in.)	mm (in.)	mm (in.)	mm (in.)	mm (in.)	mm (in.)	mm (in.)	mm (in.)	mm (in.)	mm (in.)	mm (in.)	mm (in.)	mm (in.)	mm (in.)	mm (in.)	mm (in.)	mm (in.)
MPAL-A/B5150xM32A							343.6 (13.53)			553.4 (21.79)							502.6 (19.79)
MPAL-A/B5300xM32A	110.1 (4.33)	74.9 (2.75)	85.00 (3.346)	34.4 (1.35)	146.8 (5.78)	181.9 (7.16)	496.0 (19.53)	30.00 (1.181)	1.40 (0.06)	705.8 (27.79)	155.00 (6.102)	143.6 (5.66)	M12 x 1.75 x 12 (0.07 x 0.47)	110.00 (4.331)	65.00 (2.559)	24.1 (0.95)	655.0 (25.79)
MPAL-A/B5450xM32A							648.4 (25.53)			858.2 (33.79)							807.4 (31.79)

(1) If ordering MPAL-A/B5xxxxxM4A actuator with brake, add 51.5 mm (2.03 in.) to dimensions G2, L7, and ZJ.
 (2) The tolerance for this dimension is +0.0, -0.038 mm (+0.0, -0.0015 in.).

Actuators are designed to metric dimensions. Inch dimensions are approximate conversions from millimeters. Dimensions without tolerances are for reference.

Kinetix MPAl Electric Cylinder (face-mount food-grade paint) Dimensions (Frame 64, 83, 110, and 144) MPAl-xxxxxxxE-W Face Mount (Food-grade paint) Configuration

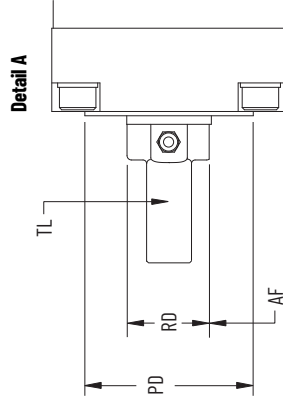
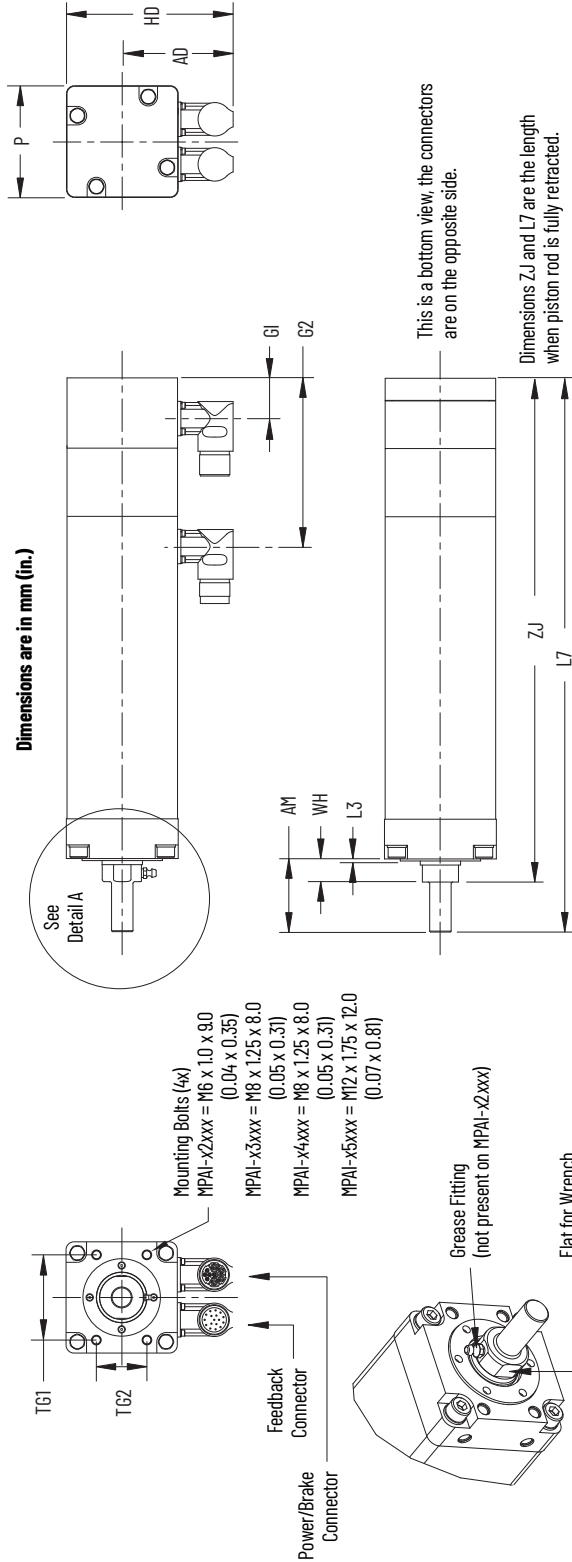

Detail A Dimensions

Frame Size	TL (threaded length, min) mm (in.)	PD (pilot diameter) mm (in.)	AF (across flats) mm (in.)	RD (rod diameter) mm (in.)
64	M10 x 1.25 x 22.1 (0.049 x 0.87)	Ø 4.955...48.000 (1.8880...1.8888)	22.74...22.99 (0.895...0.905)	Ø 25.38 (0.989)
83	M16 x 1.5 x 34.3 (0.06 x 1.35)	Ø 59.955...60.000 (2.3604...2.3622)	26.72...26.97 (1.052...1.062)	Ø 30.13 (1.186)
110	M20 x 1.5 x 41.4 (0.06 x 1.63)	Ø 71.955...72.000 (2.8328...2.8346)	34.73...34.98 (1.367...1.377)	Ø 38.08 (1.489)
144	M27 x 2.0 x 45.7 (0.08 x 1.80)	Ø 99.955...100.000 (3.9352...3.9370)	53.73...53.98 (2.115...2.125)	Ø 57.13 (2.249)

Kinetix MPAl Electric Cylinder (face-mount food-grade paint) Dimensions (Frame 64)

Electric Cylinder Cat. No.	AD mm (in.)	AM mm (in.)	G1 mm (in.)	G2 (1) mm (in.)	HD mm (in.)	L3 mm (in.)	L7 (1) mm (in.)	P mm (in.)	T61 mm (in.)	T62 mm (in.)	WH mm (in.)	ZJ (1) mm (in.)
MPAl-A/B2076CV12E-W							285.8 (11.25)					261.2 (10.28)
MPAl-A/B2150CV32E-W	72.8 (2.87)	42.1 (1.66)	26.9 (1.06)	104.6 (4.12)	104.5 (4.11)	1.8 (0.07)	362.0 (14.25) 514.4 (20.25)	63.5 (2.5)	54.0 (2.13)	20.0 (0.79)	17.5 (0.69)	337.4 (13.28)
MPAl-A/B2300CV32E-W												488.8 (19.28)

(1) If ordering MPAl-A/B2xxxVx4E-W actuator with brake, add 37.6 mm (1.48 in.) to dimensions G2, L7, and ZJ.

Kinetix MPAI Electric Cylinder (face-mount food-grade paint) Dimensions (Frame 83)

Electric Cylinder Cat. No.	AD mm (in.)	AM mm (in.)	G1 mm (in.)	G2 (1) mm (in.)	HD mm (in.)	L3 mm (in.)	L7 (1) mm (in.)	P mm (in.)	TG1 mm (in.)	TG2 mm (in.)	WH mm (in.)	ZJ (1) mm (in.)
MPAI-A/B3076xM12E-W							337.6 (13.29)					300.4 (11.83)
MPAI-A/B3150xM32E-W	82.8 (3.26)	54.9 (2.16)	30.0 (1.18)	126.0 (4.96)	124.6 (4.90)	1.8 (0.07)	413.6 (16.29)	83.6 (3.29)	68.0 (2.72)	36.0 (1.42)	17.6 (0.69)	376.6 (14.83)
MPAI-A/B3300xM32E-W							566.0 (22.29)					529.0 (20.83)
MPAI-A/B3450xM32E-W							718.4 (28.29)					681.4 (26.83)

(1) If ordering MPAI-A/B3xxxxM4E-W actuator with brake, add 47.7 mm (1.88 in.) to dimensions G2, L7, and ZJ.

Kinetix MPAI Electric Cylinder (face-mount food-grade paint) Dimensions (Frame 110)

Electric Cylinder Cat. No.	AD mm (in.)	AM mm (in.)	G1 mm (in.)	G2 (1) mm (in.)	HD mm (in.)	L3 mm (in.)	L7 (1) mm (in.)	P mm (in.)	TG1 mm (in.)	TG2 mm (in.)	WH mm (in.)	ZJ (1) mm (in.)
MPAI-A/B4150xM32E-W							466.8 (18.38)					422.3 (16.62)
MPAI-A/B4300xM32E-W	96.3 (3.79)	61.5 (2.42)	30.0 (1.18)	130.8 (5.15)	151.5 (5.96)	1.8 (0.07)	619.2 (24.38)	110.5 (4.35)	85.0 (3.35)	55.0 (2.17)	16.8 (0.66)	574.7 (22.62)
MPAI-A/B4450xM32E-W							771.6 (30.38)					727.1(28.6 2)

(1) If ordering MPAI-A/B4xxxxM4E-W actuator with brake, add 46.2 mm (1.81 in.) to dimensions G2, L7, and ZJ.

Kinetix MPAI Electric Cylinder (face-mount food-grade paint) Dimensions (Frame 144)

Electric Cylinder Cat. No.	AD mm (in.)	AM mm (in.)	G1 mm (in.)	G2 (1) mm (in.)	HD mm (in.)	L3 mm (in.)	L7 (1) mm (in.)	P mm (in.)	TG1 mm (in.)	TG2 mm (in.)	WH mm (in.)	ZJ (1) mm (in.)
MPAI-A/B5150xM32E-W							552.6 (21.76)					501.8 (19.76)
MPAI-A/B5300xM32E-W	110.1 (4.33)	75.2 (2.96)	34.0 (1.34)	146.0 (5.75)	181.9 (7.16)	1.7 (0.07)	705.0 (27.76)	143.6 (5.66)	110.00 (4.331)	65.00 (2.559)	24.4 (0.96)	654.2 (25.76)
MPAI-A/B5450xM32E-W							857.4 (33.76)					806.6 (31.76)

(1) If ordering MPAI-A/B5xxxxM4E-W actuator with brake, add 51.5 mm (2.03 in.) to dimensions G2, L7, and ZJ.

Actuators are designed to metric dimensions. Inch dimensions are approximate conversions from millimeters. Dimensions without tolerances are for reference.

Kinetix MPAl Electric Cylinder (trunnion-mount standard) Dimensions (Frame 64, 83, 110, and 144) MPAl-xxxxxxxB Trunnion Mount (standard) Configurations

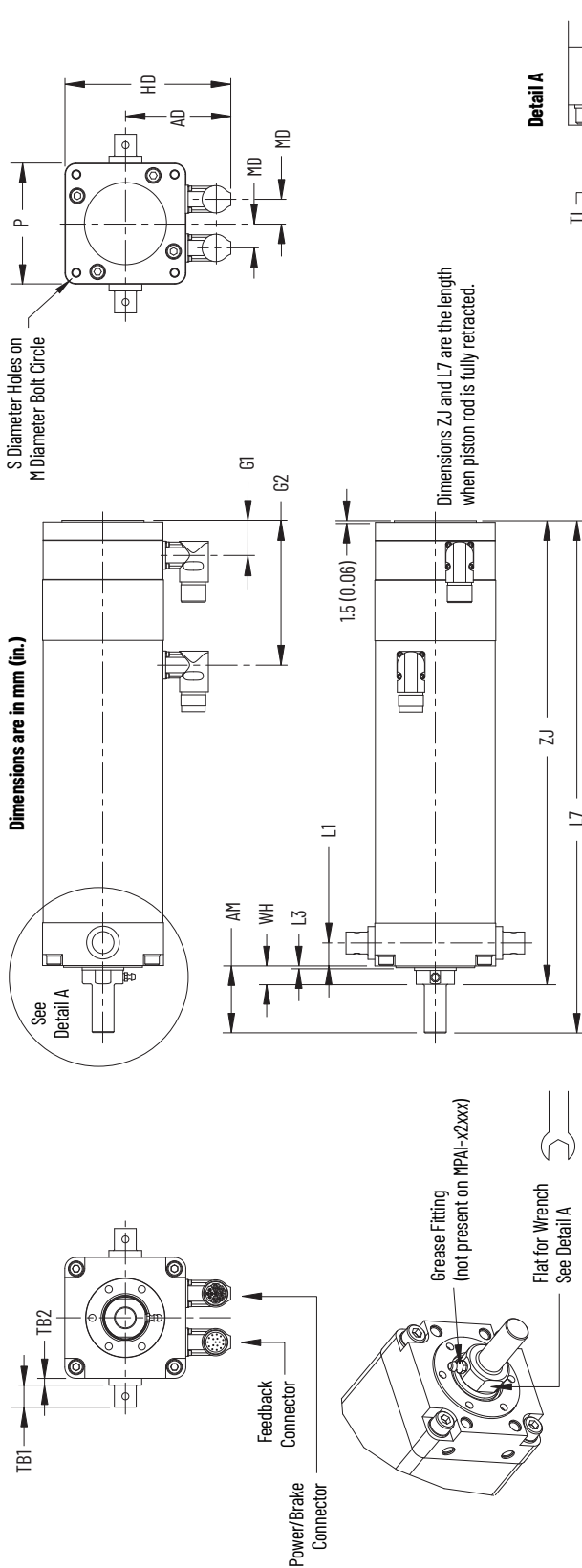

Detail A Dimensions

Frame Size	TL (threaded length, min) mm (in.)	PD (pilot diameter) mm (in.)	AF (across flats) mm (in.)	RD (rod diameter) mm (in.)	TD (trunnion diameter) mm (in.)
64	M10 x 1.25 x 22.1 (0.049 x 0.87)	Ø 4.7955...48.000 (1.8880...1.8898)	22.74...22.99 (0.895...0.905)	Ø 25.38 (0.998)	Ø 11.97...11.98 (0.471...0.472)
83	M16 x 1.5 x 34.3 (0.06 x 1.35)	Ø 59.955...60.000 (2.3604...2.3622)	26.72...26.97 (1.052...1.062)	Ø 30.13 (1.186)	Ø 15.96...15.98 (0.628...0.629)
110	M20 x 1.5 x 41.4 (0.06 x 1.63)	Ø 71.955...72.000 (2.8328...2.8346)	34.73...34.98 (1.367...1.377)	Ø 38.08 (1.498)	Ø 19.96...19.98 (0.786...0.787)
144	M27 x 2.0 x 45.7 (0.08 x 1.80)	Ø 99.955...100.000 (3.9352...3.9370)	53.73...53.98 (2.115...2.125)	Ø 57.13 (2.249)	Ø 24.97...24.99 (0.983...0.984)

Kinetix MPAl Electric Cylinder (trunnion-mount standard) Dimensions (Frame 64)

Electric Cylinder Cat. No.	AD mm (in.)	AM mm (in.)	G1 mm (in.)	G2 (1) mm (in.)	HD mm (in.)	L1 mm (in.)	L3 mm (in.)	L7 (1) mm (in.)	M (2) mm (in.)	MD mm (in.)	P mm (in.)	S mm (in.)	TB1 mm (in.)	TB2 mm (in.)	WH mm (in.)	ZJ (1) mm (in.)
MPAl-A/B2076CV2B								288.1 (11.34)								263.5 (10.37)
MPAl-A/B2150CV3ZB	72.8 (2.87)	419 (1.65)	28.8 (1.13)	106.9 (4.21)	104.5 (4.11)	15.0 (0.591)	1.5 (0.06)	364.3 (14.34)	70.00 (2.756)	9.5 (0.38)	63.5 (2.50)	M6 x 1.0 x 9 (0.04 x 0.35)	8.7 (0.34)	2.3 (0.09)	17.3 (0.68)	339.7 (13.37)
MPAl-A/B2300CV3ZB								516.7 (20.34)								492.1 (19.37)

(1) If ordering MPAl-A/B2xxxxxB actuator with brake, add 37.6 mm (1.48 in.) to dimensions G2, L7, and ZJ.

(2) The tolerance for this dimension is +0.0, -0.038 mm (+0.0, -0.0015 in.).

Kinetix MPAI Electric Cylinder (trunnion-mount standard) Dimensions (Frame 833)

Electric Cylinder Cat. No.	AD mm (in.)	AM mm (in.)	G1 mm (in.)	G2 (1) mm (in.)	HD mm (in.)	L1 mm (in.)	L3 mm (in.)	L7 (1) mm (in.)	M (2) mm (in.)	MD mm (in.)	P mm (in.)	S mm (in.)	TB1 mm (in.)	TB2 mm (in.)	WH mm (in.)	ZJ (1) mm (in.)
MPAI-A/B3150xM32B								413.6 (16.29)								376.3 (14.81)
MPAI-A/B3300xM32B	82.8 (3.26)	54.6 (2.15)	30.4 (1.20)	127.5 (5.02)	124.6 (4.90)	15.00 (0.59)	1.5 (0.06)	566.0 (22.29)	92.0 (3.622)	16.8 (0.66)	83.6 (3.29)	M8 x 1.25 x12 (0.05 x 0.47)	16.0 (0.63)	3.2 (0.13)	17.3 (0.68)	528.7 (20.81)
MPAI-A/B3450xM32B								718.4 (28.29)								681.1 (26.81)

(1) If ordering MPAI-A/B3xxxxM4B actuator with brake, add 47.7 mm (1.88 in.) to dimensions G2, L7, and ZJ.

(2) The tolerance for this dimension is +0.0, -0.038 mm (+0.0, -0.0015 in.).

Kinetix MPAI Electric Cylinder (trunnion-mount standard) Dimensions (Frame 110)

Electric Cylinder Cat. No.	AD mm (in.)	AM mm (in.)	G1 mm (in.)	G2 (1) mm (in.)	HD mm (in.)	L1 mm (in.)	L3 mm (in.)	L7 (1) mm (in.)	M (2) mm (in.)	MD mm (in.)	P mm (in.)	S mm (in.)	TB1 mm (in.)	TB2 mm (in.)	WH mm (in.)	ZJ (1) mm (in.)
MPAI-A/B4150xM32B								466.6 (18.37)								422.1 (16.62)
MPAI-A/B4300xM32B	96.3 (3.79)	61.3 (2.41)	30.4 (1.20)	130.7 (5.15)	151.5 (5.96)	21.00 (0.83)	1.5 (0.06)	619.0 (24.37)	127.0 (5.0)	22.2 (0.87)	110.5 (4.35)	M8 x 1.25 x12 (0.05 x 0.47)	20.05 (0.79)	6.25 (0.25)	16.8 (0.66)	574.5 (22.62)
MPAI-A/B4450xM32B								771.4 (30.37)								726.9 (28.62)

(1) If ordering MPAI-A/B4xxxxM4B actuator with brake, add 46.2 mm (1.81 in.) to dimensions G2, L7, and ZJ.

(2) The tolerance for this dimension is +0.0, -0.038 mm (+0.0, -0.0015 in.).

Kinetix MPAI Electric Cylinder (trunnion-mount standard) Dimensions (Frame 144)

Electric Cylinder Cat. No.	AD mm (in.)	AM mm (in.)	G1 mm (in.)	G2 (1) mm (in.)	HD mm (in.)	L1 mm (in.)	L3 mm (in.)	L7 (1) mm (in.)	M (2) mm (in.)	MD mm (in.)	P mm (in.)	S mm (in.)	TB1 mm (in.)	TB2 mm (in.)	WH mm (in.)	ZJ (1) mm (in.)
MPAI-A/B5150xM32B								553.4 (21.79)								502.6 (19.79)
MPAI-A/B5300xM32B	110.1 (4.33)	74.9 (2.95)	34.4 (1.35)	146.8 (5.78)	181.9 (7.16)	28.0 (1.10)	1.4 (0.06)	705.8 (27.79)	155.0 (6.10)	22.2 (0.88)	143.6 (5.66)	M12 x 1.75 x12 (0.07 x 0.47)	24.9 (0.98)	8.2 (0.32)	24.1 (0.95)	655.0 (25.79)
MPAI-A/B5450xM32B								858.2 (33.79)								807.4 (31.79)

(1) If ordering MPAI-A/B5xxxxM4B actuator with brake, add 51.5 mm (2.03 in.) to dimensions G2, L7, and ZJ.

(2) The tolerance for this dimension is +0.0, -0.038 mm (+0.0, -0.0015 in.).

Actuators are designed to metric dimensions. Inch dimensions are approximate conversions from millimeters. Dimensions without tolerances are for reference.

Kinetix MPAl Electric Cylinder (clevis-mount food-grade paint) Dimensions (Frame 64, 83, 110, and 144) MPAl-xxxxxxx-C-W Clevis Mount (Food-grade paint) Configurations

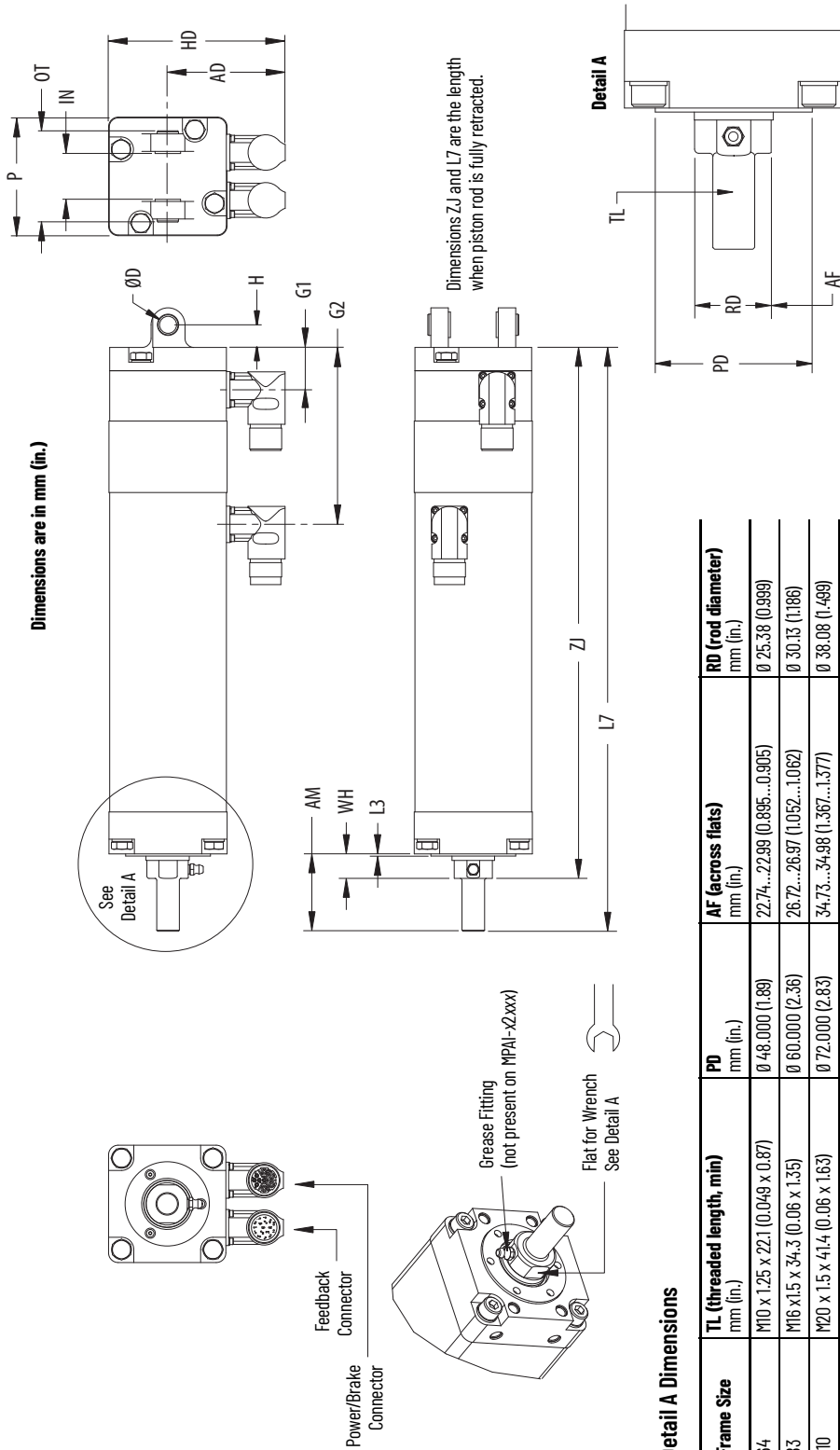

Detail A Dimensions

Frame Size	TL (threaded length, min) mm (in.)	PD mm (in.)	AF (across flats) mm (in.)	RD (rod diameter) mm (in.)
64	M10 x 1.25 x 22.1 (0.049 x 0.87)	Ø 48.000 (1.89)	22.74...22.99 (0.895...0.905)	Ø 25.38 (0.999)
83	M16 x 1.5 x 34.3 (0.06 x 1.35)	Ø 60.000 (2.36)	26.72...26.97 (1.052...1.062)	Ø 30.13 (1.186)
110	M20 x 1.5 x 41.4 (0.06 x 1.63)	Ø 72.000 (2.83)	34.73...34.98 (1.367...1.377)	Ø 38.08 (1.499)
144	M27 x 2.0 x 45.7 (0.08 x 1.80)	Ø 100.000 (3.94)	53.73...53.98 (2.115...2.125)	Ø 57.13 (2.249)

Kinetix MPAl Electric Cylinder (clevis-mount food-grade paint) Dimensions (Frame 64)

Electric Cylinder Cat. No.	AD mm (in.)	AM mm (in.)	ØD mm (in.)	G1 mm (in.)	G2 (1) mm (in.)	H mm (in.)	HD mm (in.)	IN mm (in.)	L3 mm (in.)	L7 (1) mm (in.)	OT mm (in.)	P mm (in.)	WH mm (in.)	ZJ (1) mm (in.)
MPAl-A/B2076CV12C-W			10.01...10.02 (0.394...0.395)			13.0 (0.51)	104.5 (4.11)	26.3 (1.03)	1.5 (0.06)	285.8 (11.25)	46.25 (1.821)	63.5 (2.50)	17.3 (0.68)	261.2 (10.28)
MPAl-A/B2150CV32C-W	72.8 (2.87)	41.9 (1.65)		26.9 (1.06)	104.6 (4.12)					362.0 (14.25)				337.4 (13.28)
MPAl-A/B2300CV32C-W										514.4 (20.25)				488.8 (19.28)

(1) If ordering MPAl-A/B2xxxxx4C-W actuator with brake, add 37.6 mm (1.48 in.) to dimensions G2, L7, and ZJ.

Kinetix MPAI Electric Cylinder (clevis-mount food-grade paint) Dimensions (Frame 83)

Electric Cylinder Cat. No.	AD mm (in.)	AM mm (in.)	ØD mm (in.)	G1 mm (in.)	G2 (1) mm (in.)	H mm (in.)	HD mm (in.)	IN mm (in.)	L3 mm (in.)	L7 (1) mm (in.)	OT mm (in.)	P mm (in.)	WH mm (in.)	ZJ (1) mm (in.)
MPAI-A/B3076xM12C-W										337.4 (13.28)				300.1 (11.81)
MPAI-A/B3150xM132C-W	82.8 (3.26)	54.6 (2.15)	12.01 (0.473)	30.0 (1.18)	127.5 (5.02)	16.0 (0.630)	124.6 (4.90)	32.3 (1.27)	1.50 (0.06)	413.6 (16.29)	64.3 (2.53)	83.6 (3.29)	17.3 (0.68)	376.3 (14.81)
MPAI-A/B3300xM132C-W										566.0 (22.29)				528.7 (20.81)
MPAI-A/B3450xM132C-W										718.4 (28.29)				681.1 (26.81)

(1) If ordering MPAI-A/B3xxxxM4C-W actuator with brake, add 47.7 mm (1.88 in.) to dimensions G2, L7, and ZJ.

Kinetix MPAI Electric Cylinder (clevis-mount food-grade paint) Dimensions (Frame 110)

Electric Cylinder Cat. No.	AD mm (in.)	AM mm (in.)	ØD mm (in.)	G1 mm (in.)	G2 (1) mm (in.)	H mm (in.)	HD mm (in.)	IN mm (in.)	L3 mm (in.)	L7 (1) mm (in.)	OT mm (in.)	P mm (in.)	WH mm (in.)	ZJ (1) mm (in.)
MPAI-A/B4150xM132C-W										466.6 (18.37)				422.1 (16.62)
MPAI-A/B4300xM132C-W	96.3 (3.79)	61.3 (2.41)	16.01 (0.630)	30.0 (1.18)	130.7 (5.15)	22.0 (0.866)	151.5 (5.96)	50.3 (1.98)	1.50 (0.06)	619.0 (24.37)	94.3 (3.71)	110.5 (4.35)	16.8 (0.66)	574.5 (22.62)
MPAI-A/B4450xM132C-W										771.4 (30.37)				726.9 (28.62)

(1) If ordering MPAI-A/B4xxxxM4C-W actuator with brake, add 46.2 mm (1.82 in.) to dimensions G2, L7, and ZJ.

Kinetix MPAI Electric Cylinder (clevis-mount food-grade paint) Dimensions (Frame 144)

Electric Cylinder Cat. No.	AD mm (in.)	AM mm (in.)	ØD (1) mm (in.)	G1 mm (in.)	G2 (2) mm (in.)	H mm (in.)	HD mm (in.)	IN mm (in.)	L3 mm (in.)	L7 (1) mm (in.)	OT mm (in.)	P mm (in.)	WH mm (in.)	ZJ (1) mm (in.)
MPAI-A/B5150xM132C-W										552.6 (21.76)				501.8 (19.76)
MPAI-A/B5300xM132C-W	110.1 (4.33)	74.9 (2.95)	20.02 (0.788)	34.0 (1.34)	146.0 (5.75)	27.0 (1.063)	181.9 (7.16)	60.33 (2.375)	1.40 (0.06)	705.0 (27.76)	114.30 (4.500)	143.6 (5.66)	24.1 (0.95)	654.2 (25.76)
MPAI-A/B5450xM132C-W										857.4 (33.76)				806.6 (31.76)

(1) Tolerance for this dimension is +0.02 mm (+0.001 in.)

(2) If ordering MPAI-A/B5xxxxM4C-W actuator with brake, add 51.5 mm (2.03 in.) to dimensions G2, L7, and ZJ.

Actuators are designed to metric dimensions. Inch dimensions are approximate conversions from millimeters. Dimensions without tolerances are for reference.

Accessories - Kinetix MPAI Heavy-duty Electric Cylinders

Mounting Accessories

These accessories apply to standard-mount electric cylinders. Components are designed to metric dimensions. Inch dimensions are approximate conversions from millimeters. Dimensions without tolerances are for reference.

Mounting Plates Attachment

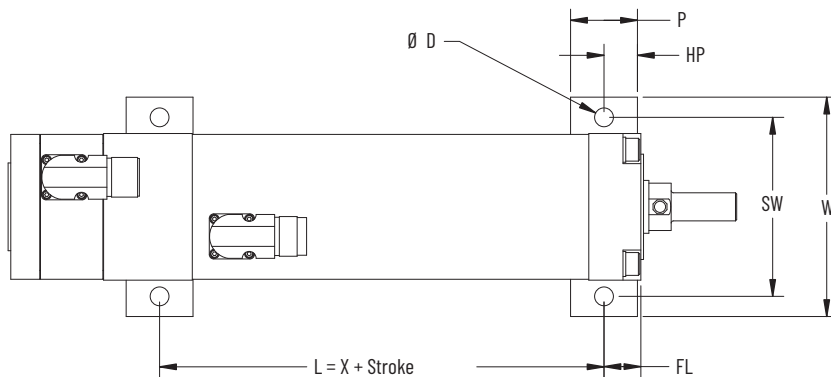

Dimensions are in mm (in.)

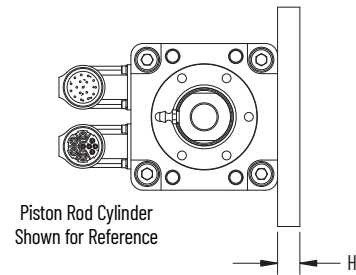

Cat. No. (1)	Frame	X mm (in.)	FL mm (in.)	D mm (in.)	P mm (in.)	HP mm (in.)	SW mm (in.)	W mm (in.)	H mm (in.)
MPAI-NA206	64	67.8 (2.67)	20.0 (0.79)	8.7 (0.34)	30.0 (1.18)	15.0 (0.59)	80.0 (3.15)	100 (3.94)	11.0 (0.43)
MPAI-NA306	83	100.7 (3.96)	21.0 (0.83)	10.7 (0.42)	38.1 (1.50)	19.05 (0.75)	102 (4.02)	125 (4.92)	12.7 (0.50)
MPAI-NA406	110	143 (5.63)	25.0 (0.98)				130 (5.12)	155 (6.10)	
MPAI-NA506	144	343.6 (13.53)	30.0 (1.18)	15.1 (0.59)	50.0 (1.97)	25.0 (0.98)	170 (6.69)	200 (7.87)	20.0 (0.79)

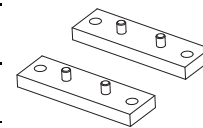

- Attachment includes:
- 2 mounting plates
 - Mounting hardware

This accessory applies to:

- Kinetix MPAI Standard
- Kinetix MPAI Food Grade Paint

(1) Material is carbon steel and finish is melonite. Contains no copper, PTFE, or silicone.

Rear Clevis Mount Attachment

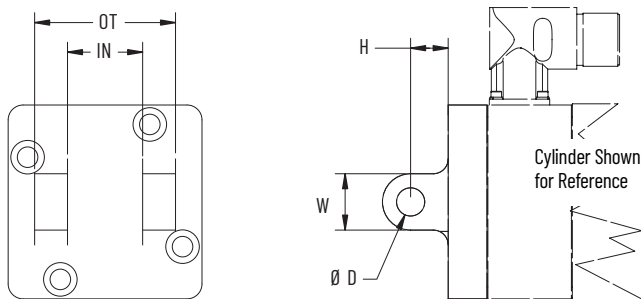

Dimensions are in mm (in.)

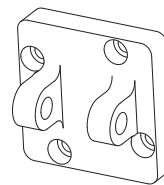

Attachment includes replacement gasket.

This accessory applies to:

- Kinetix MPAI Standard
- Kinetix MPAI Food Grade Paint

Cat. No. (1)	Frame	ØD (2) mm (in.)	IN (3) mm (in.)	OT (4) mm (in.)	W mm (in.)	H mm (in.)
MPAI-NA203	64	10.0 (0.39)	26.0 (1.02)	45.0 (1.77)	20.0 (0.787)	13.0 (0.512)
MPAI-NA303	83	12.0 (0.4724)	32.0 (1.260)	60.0 (2.36)	24.0 (0.945)	16.0 (0.630)
MPAI-NA403	110	16.0 (0.6299)	50.0 (1.9685)	90.0 (3.54)	36.0 (1.417)	22.0 (0.866)
MPAI-NA503	144	20.0 (0.7874)	60.0 (2.3622)	110 (4.3307)	40.0 (1.575)	27.0 (1.063)



Rear clevis mount attachments for food-grade paint configurations are factory pre-assembled. Refer to the figure on [page 118](#).

- (1) Material is carbon steel and finish is melonite. Contains no copper, PTFE, or silicone.
- (2) Tolerance for this dimension is +0.043, -0 mm (+0.017, -0 in.).
- (3) Tolerance for this dimension is +0.62, -0 mm (+0.024, -0 in.).
- (4) Tolerance for this dimension is +0, -0.62 mm (+0, -0.024 in.).

Front Flange Attachment

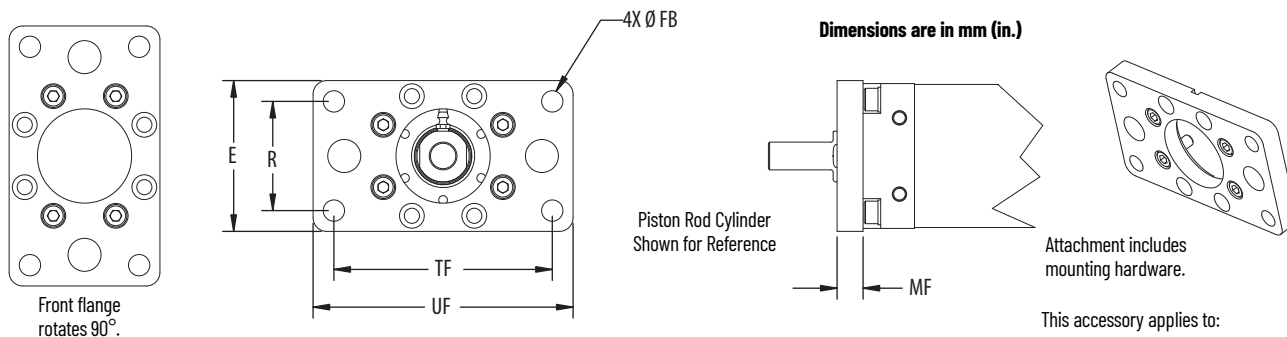

Dimensions are in mm (in.)

Attachment includes mounting hardware.

This accessory applies to:

- Kinetix MPAI Standard
- Kinetix MPAI Food Grade Paint

Cat. No.	Frame	E mm (in.)	ØFB mm (in.)	MF mm (in.)	R mm (in.)	TF mm (in.)	UF mm (in.)
MPAI-NA201	64	67.3 (1.47)	8.7 (0.34)	11.2 (0.44)	50.0 (1.97)	100 (3.94)	117.4 (4.62)
MPAI-NA221							
MPAI-NA301 (1)	83	87.0 (3.43)	12.3 (0.48)	15.0 (0.59)	63.0 (2.48)	126 (4.96)	150 (5.90)
MPAI-NA321 (2)							
MPAI-NA401 (1)	110	110.5 (4.35)	14.7 (0.58)	16.0 (0.63)	75.0 (2.95)	150 (5.90)	170 (6.69)
MPAI-NA421 (2)							
MPAI-NA501 (1)	144	150 (5.91)	16.7 (0.66)	17.8 (0.70)	115 (4.53)	230 (9.05)	260 (10.24)
MPAI-NA521 (2)							

- (1) Material is carbon steel and finish is melonite. Contains no copper, PTFE, or silicone.
- (2) Material is stainless steel, type 316.

Anti-rotation Option Accessory

The Kinetix MPAI actuator design lets the extending rod rotate. This provides simple setup of the actuator letting you rotate the rod and thread it in and out of the actuator for mechanical attachment or system testing. This feature also requires that the rod be kept from rotating when used in its dedicated application for proper linear motion. In most applications, for example, where the load is coupled to linear bearings or some support device, the load cannot rotate and thus provides anti-rotation for the extending actuator rod. For applications where the load is free to rotate, Allen-Bradley offers the anti-rotation option as shown on [page 136](#).

IMPORTANT The anti-rotation option is not a guide or support mechanism. It is intended as only an anti-rotation device.

Anti-rotation Option for Fixed Strokes

Cat. No. Frame 64	Stroke mm (in.)
MPAI-NE20276	76.2 (3.0)
MPAI-NE20215	152.4 (6.0)
MPAI-NE20230	304.8 (12.0)

Cat. No. Frame 83	Stroke mm (in.)
MPAI-NE30276	76.2 (3.0)
MPAI-NE30215	152.4 (6.0)
MPAI-NE30230	304.8 (12.0)
MPAI-NE30245	457.2 (18.0)

Cat. No. Frame 110	Stroke mm (in.)
MPAI-NE40215	152.4 (6.0)
MPAI-NE40230	304.8 (12.0)
MPAI-NE40245	457.2 (18.0)

Cat. No. Frame 144	Stroke mm (in.)
MPAI-NE50215	152.4 (6.0)
MPAI-NE50230	304.8 (12.0)
MPAI-NE50245	457.2 (18.0)

Anti-rotation Option Material Specifications

You can mount the anti-rotation option from either side of the standard mount cylinder.

Item	Attribute	Value ⁽¹⁾
1	Rod	C1060 ground hardened steel
2	Bearing block	Anodized aluminium
3	Clamp	Zinc-plated carbon steel

(1) Contains no copper, PTFE, or silicone.

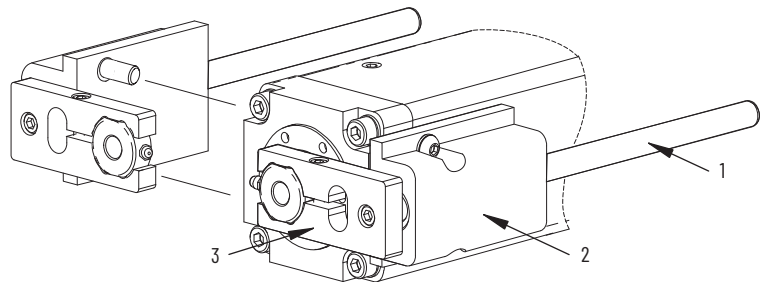

Anti-rotation Option Dimensions

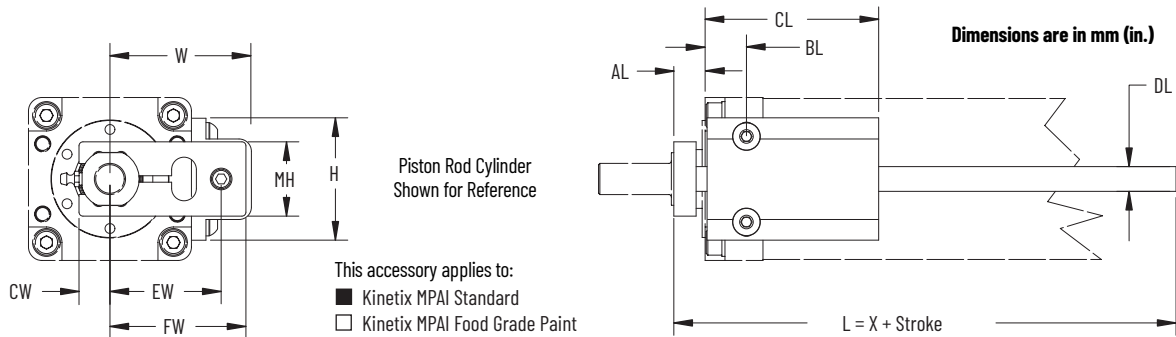

When the anti-rotate option is used in conjunction with a front flange attachment, the actuator total stroke length is reduced by this amount.

Frame	Value
64	7.6 (0.30)
83	11.4 (0.45)
110	13.0 (0.51)
144	11.2 (0.44)

Cat. No.	Frame	Stroke	X mm (in.)	L mm (in.)	AL mm (in.)	BL mm (in.)	CL mm (in.)	DL mm (in.)	W mm (in.)	CW mm (in.)	EW mm (in.)	FW mm (in.)	H mm (in.)	MH mm (in.)
MPAI-NE20276	64	076		157.2 (6.19)										
MPAI-NE20215		150	81.0 (3.19)	233.4 (9.19)	17.4 (0.68)	18.5 (0.73)	63.5 (2.50)	9.5 (0.37)	54.9 (2.16)	12.7 (0.50)	43.3 (1.70)	51.2 (2.01)	46.2 (1.82)	34.9 (1.37)
MPAI-NE20230		300		385.8 (15.19)										
MPAI-NE30276	83	076		181.4 (7.14)										
MPAI-NE30215		150	105.2 (4.14)	257.6 (10.14)	17.1 (0.67)	20.0 (0.79)	88.0 (3.46)	12.7 (0.50)	72.3 (2.85)	15.9 (0.63)	57.0 (2.24)	69.7 (2.74)	62.7 (2.47)	38.1 (1.50)
MPAI-NE30230		300		410.0 (16.14)										
MPAI-NE30245		450		562.4 (22.14)										
MPAI-NE40215	110	150		260.9 (10.27)										
MPAI-NE40230		300	108.5 (4.27)	413.3 (16.27)	17.1 (0.67)	20.0 (0.79)	88.0 (3.46)	12.7 (0.50)	85.7 (3.37)	19.8 (0.78)	70.5 (2.78)	83.2 (3.28)	64.3 (2.53)	45.9 (1.81)
MPAI-NE40245		450		565.7 (22.27)										
MPAI-NE50215	144	150		294.9 (11.6)										
MPAI-NE50230		300	142.5 (5.60)	447.3 (17.6)	25.4 (1.00)	27.5 (1.08)	113.0 (4.55)	19.0 (0.75)	118.3 (4.66)	31.8 (1.25)	95.1 (3.74)	109.7 (4.32)	106.7 (4.20)	68.2 (2.69)
MPAI-NE50245		450		599.7 (23.6)										

Rod-end Accessories

These accessories apply to standard and front trunnion-mount electric cylinders. Components are designed to metric dimensions. Inch dimensions are approximate conversions from millimeters. Dimensions without tolerances are for reference.

Rod-eye Attachment

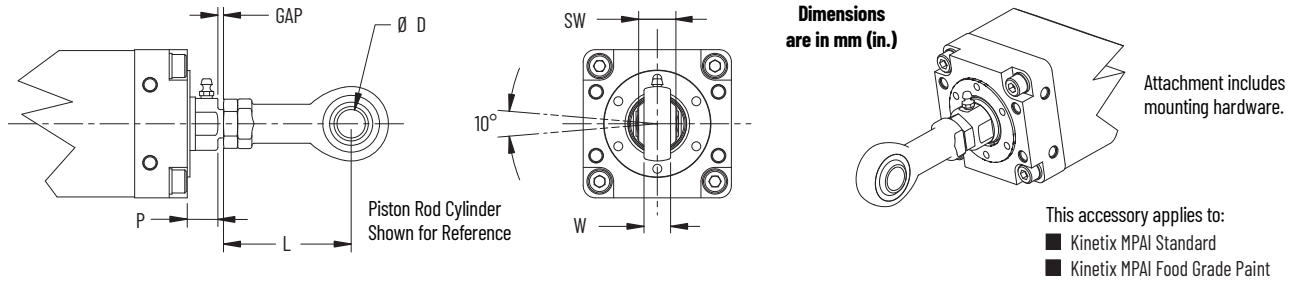

Cat. No.	Frame	ØD mm (in.)	P mm (in.)	L mm (in.)	W mm (in.)	SW mm (in.)	GAP mm (in.)
MPAI-NE203 ⁽¹⁾	64	10.0 (0.39)	17.3 (0.68)	48.0 (1.89)	10.5 (0.41)	14.0 (0.55)	2.5...9.6 (0.10...0.38)
MPAI-NE223 ⁽²⁾							
MPAI-NE303 ⁽¹⁾	83	16.0 (0.63)	17.3 (0.68)	72.0 (2.83)	15.0 (0.59)	21.0 (0.83)	3.0...13.3 (0.12...0.52)
MPAI-NE323 ⁽²⁾							
MPAI-NE403 ⁽¹⁾	110	20.0 (0.79)	16.8 (0.66)	87.0 (3.43)	18.0 (0.71)	25.0 (0.98)	3.0...14.5 (0.12...0.57)
MPAI-NE423 ⁽²⁾							
MPAI-NE503 ⁽¹⁾	144	30.0 (1.18)	24.1 (0.95)	123.5 (4.86)	25.0 (0.94)	37.0 (1.46)	5.1...10.3 (0.20...0.41)
MPAI-NE523 ⁽²⁾							

(1) Material is steel and finish is clear zinc.

(2) Material is high-alloy steel for environments requiring higher corrosion resistance. Contains no copper, PTFE, or silicone.

IMPORTANT The spherical rod-eye attachment must be used with an anti-rotation option or the load that the actuator is attached to must be kept from rotating. Without one of these two methods, the spherical rod-eye lets the actuator rod rotate and result in inaccurate positioning due to lost rotational motion.

Rod Clevis Attachment

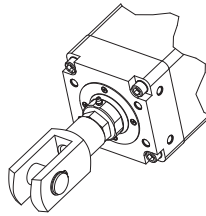
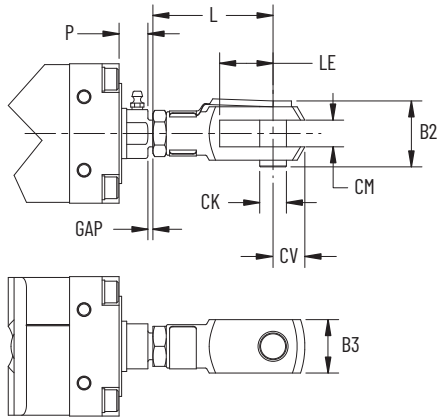

Piston Rod Cylinder Shown for Reference

Dimensions are in mm (in.)

- Attachment includes:
- 1 Rod clevis
 - 1 Hinged spring pin
 - 1 Hex nut

- This accessory applies to:
- Kinetix MPAI Standard
 - Kinetix MPAI Food Grade Paint

Cat. No. (1)	Frame	B2 mm (in.)	B3 mm (in.)	ØCK mm (in.) H9	CM mm (in.)	CV mm (in.)	LE mm (in.)	L mm (in.)	P mm (in.)	GAP mm (in.)
MPAI-NE204	64	27.0 (1.06)	20.0 (0.79)	10.0 (0.39)	10.0 (0.39)	11.2 (0.44)	20.0 (0.79)	45.0 (1.77)	17.3 (0.68)	2.5...9.6 (0.10...0.38)
MPAI-NE304	83	40.0 (1.57)	32.0 (1.26)	16.0 (0.63)	16.0 (0.63)	19.0 (0.75)	32.0 (1.26)	72.0 (2.83)	17.3 (0.68)	3.0...13.1 (0.12...0.52)
MPAI-NE404	110	48.0 (1.89)	40.0 (1.57)	20.0 (0.79)	20.0 (0.79)	25.0 (0.98)	40.0 (1.57)	90.0 (3.54)	16.8 (0.66)	3.0...14.5 (0.12...0.57)
MPAI-NE504	144	65.0 (2.56)	55.0 (2.17)	30.0 (1.18)	30.0 (1.18)	40.3 (1.59)	54.0 (2.13)	123.5 (4.86)	24.1 (0.95)	3.0...10.3 (0.12...0.41)

(1) Material is galvanized steel.

Self-aligning Rod Coupler

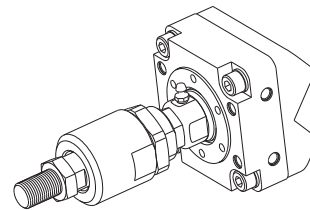
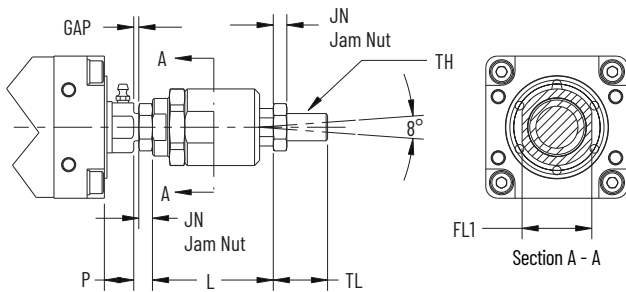

Dimensions are in mm (in.)

- Attachment includes:
- 1 Self-aligning rod coupler
 - 1 Hex nut

- This accessory applies to:
- Kinetix MPAI Standard
 - Kinetix MPAI Food Grade Paint

Cat. No. (1)	Frame	TH mm (in.)	TL mm (in.)	L mm (in.)	P mm (in.)	JN mm (in.)	FL1 mm (in.)	GAP mm (in.)
MPAI-NE201	64	M10 x 1.25	20.0 (0.79)	49.5 (1.95)	17.3 (0.68)	6.0 (0.24)	30.0 (1.18)	2.5...9.6 (0.10...0.38)
MPAI-NE301	83	M16 x 1.50	32.0 (1.26)	71.0 (2.80)	17.3 (0.68)	8.0 (0.31)	41.0 (1.61)	3.0...13.3 (0.12...0.52)
MPAI-NE401	110	M20 x 1.50	40.0 (1.57)	80.0 (3.15)	16.8 (0.66)	10.0 (0.39)	41.0 (1.61)	3.1...14.5 (0.12...0.57)
MPAI-NE501	144	M27 x 2.0	54.0 (2.13)	103 (4.06)	24.1 (0.95)	13.5 (0.53)	55.0 (2.17)	5.1...10.3 (0.20...0.41)

(1) Material is steel and finish is clear zinc.

Kinetix LDC Iron Core Linear Servo Motors



The Kinetix LDC iron core linear motors address a growing interest in linear motor technology as it becomes more affordable and is increasingly recognized as a practical means of improving machine performance. With the iron core product design, you now have cost-effective options to help you improve machine throughput while reducing maintenance and downtime.

Kinetix LDC Iron Core Linear Motor Features

- High thrust force to cost ratio lets you use smaller, less expensive motors.
- Cogging torque less than 5% of continuous force.
- Very high acceleration and speeds up to 10 m/s (32.8 ft/s) greatly increase the throughput of your machine.
- No limits to travel distance. Ability to achieve high speeds over short and long travels.
- Direct drive technology for extreme servo responsiveness.
- No-wear, high reliability parts increase productivity.
- Peak forces to 5246 N (1179 lb).
- Ability to size and optimize Kinetix LDC iron-core linear motors and corresponding servo drives by using Motion Analyzer software reduces product selection time and minimizes cost.
- Full set-up and programming support with the Studio 5000 Logix Designer application reduces set-up time.

Motor Connector/Cable Compatibility

Kinetix LDC iron-core linear motors are equipped with SpeedTec-ready DIN connectors. However, these motors have incremental encoders and must use threaded DIN (M4) feedback cables in non-flex applications. This is due to the number of conductors required for incremental encoder connections.

Kinetix LDC Iron Core Linear Motors

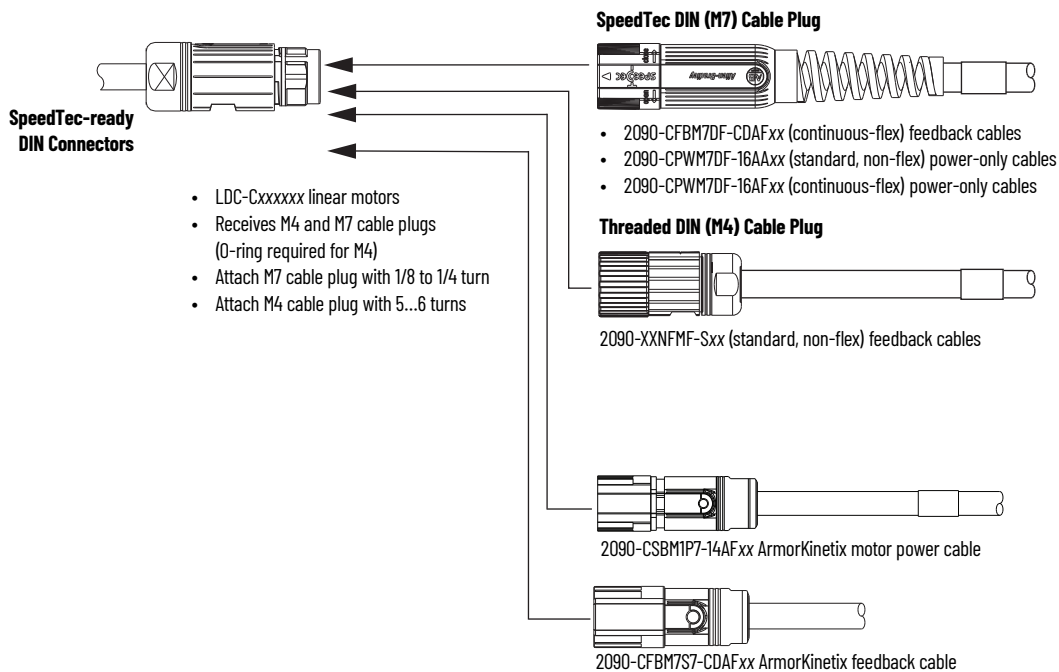

Catalog Numbers - Kinetix LDC Iron Core Linear Motors

Catalog numbers consist of various characters, each of which identifies a specific option for that component. Use the catalog numbering table chart below to understand the configuration of your actuator. For questions regarding product availability, contact your Allen-Bradley distributor.

Kinetix LDC Iron Core Linear Motors

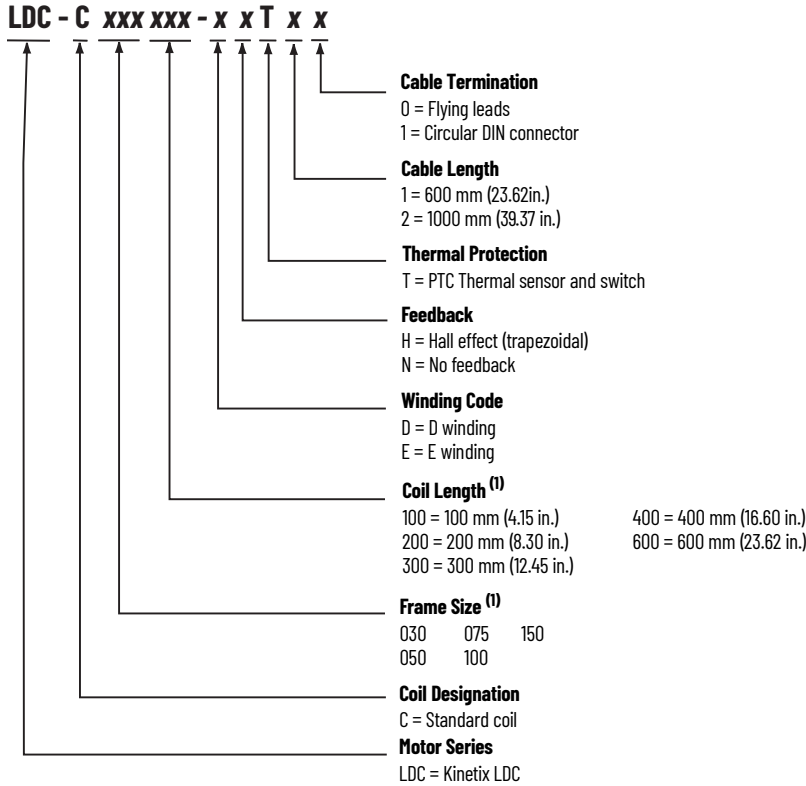

(1) Not all combinations are available. Only the configurations as listed in Technical Specifications - Kinetix LDC Iron Core Linear Motors on [page 143](#) are available.

Kinetix LDC Iron Core Linear Motor Magnet Track and Cooling Plates

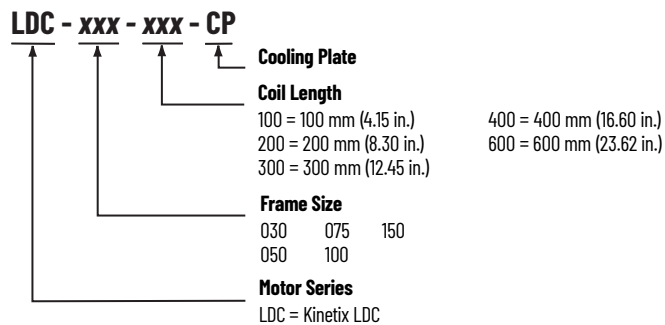
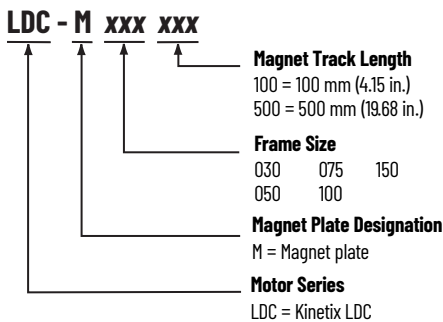

Accessories - Kinetix LDC Iron Core Linear Motors

- Cooling plates
- Bulk head connector kit
- Encoder connector kit
- Hall effect replacement module for connectorized coil
- Hall effect replacement module for flying-lead coil

Accessories for Kinetix LDC Iron Core Linear Motors

Cat. No.	Accessory	Description
LDC-BULK-HD	Bulk head connector kit	For easy mounting of flex cable to non-flex cables. Kit includes flange for feedback and power connectors, o-rings, and nut. Refer to Bulk Head Connector Flange Dimensions on page 160 .
LDC-ENC-CNCT	Encoder connector kit	Adapts your encoder to the feedback cable on the Hall effect module.
LDC-HALL-C	Hall effect module	Replacement module for use with connectorized coil.
LDC-HALL-F		Replacement module for use with flying-lead coil.

Cooling Plate Accessories for Kinetix LDC Iron Core Linear Motors

Coil Cat. No.	Cooling Plate Cat. No.
LDC-C030100-xxxxx	LDC-030-100-CP
LDC-C030200-xxxxx	LDC-030-200-CP
LDC-C050100-xxxxx	LCC-050-100-CP
LDC-C050200-xxxxx	LDC-050-200-CP
LDC-C050300-xxxxx	LCC-050-300-CP
LDC-C075200-xxxxx	LDC-075-200-CP
LDC-C075300-xxxxx	LDC-075-300-CP
LDC-C075400-xxxxx	LDC-075-400-CP
LDC-C100300-xxxxx	LDC-100-300-CP
LDC-C100400-xxxxx	LDC-100-400-CP
LDC-C100600-xxxxx	LDC-100-600-CP
LDC-C150400-xxxxx	LDC-150-400-CP
LDC-C150600-xxxxx	LDC-150-600-CP

Technical Specifications - Kinetix LDC Iron Core Linear Motors

These performance specifications apply to all Kinetix LDC iron core linear motors.

Common Performance Specifications

Attribute	Value
Motor type	3 phase, wye winding, synchronous permanent magnet stator, non-ventilated linear motor
Operating speed, max	10 m/s (32.8 ft/s)
Operating voltage, (not for direct connection to AC line)	460V AC rms
Dielectric rating of motor power connections (U,V,W), to ground for 1.0 s ⁽¹⁾	2500V AC rms 50/60 Hz
Cogging torque	< 5% of the continuous force
Applied bus voltage, max ⁽²⁾	650V DC
Electrical cycle length	50 mm (1.9685 in.)
Coil temperature, max	130 °C (266 °F)
Insulation class	130 °C (266 °F) Class B
Thermal time constant, Ref, winding to ambient	45 min
Paint color	Black

(1) Tested during manufacturing process. Do not re-apply test voltage. Contact Application Engineering (631.344.6600) for advice on testing coils post production.

(2) Maximum cable length is 10 m (32.8 ft). Consult Application Engineering (631.344.6600) for applications requiring longer cables.

Motor performance specifications are with sinusoidal commutation. Cooling options include NC (no cooling), AC (air cooling), and WC (water cooling).

Kinetix LDC Iron Core Linear Motors (30 mm frame size)

Attribute	Units	Symbol	LDC-C030100-DxTxx			LDC-C030200-DxTxx			LDC-C030200-ExTxx		
			NC	AC	WC	NC	AC	WC	NC	AC	WC
Force, continuous ^{(1) (2) (3)}	N (lbf)	F_c	74 (17)	93 (21)	111 (25)	148 (33)	185 (42)	222 (50)	148 (33)	185 (42)	222 (50)
Force, peak ⁽⁴⁾	N (lbf)	F_p	188 (42)			375 (84)					
Thermal resistance	°C/W	R_{th}	2.24	1.43	1.00	1.12	0.72	0.50	1.12	0.72	0.50
Force constant ^{(5) (6) (7)}	N/A _{pk} (lbf/A _{pk})	K_f	18.2 (4.1)			18.2 (4.1)			36.4 (8.2)		
Back EMF constant p-p ^{(5) (6) (7)}	V _p /m/s (V _p /in/s)	K_e	21.5 (0.55)			21.5 (0.55)			43.0 (1.09)		
Current, peak ^{(4) (6)}	A _{pk} (A _{rms})	I_p	12.1 (8.6)			24.3 (17.1)			12.1 (8.6)		
Current, continuous ^{(1) (2) (3) (6)}	A _{pk} (A _{rms})	I_c	4.1 (2.88)	5.1 (3.6)	6.1 (4.3)	8.1 (5.8)	10.2 (7.2)	12.2 (8.6)	4.1 (2.9)	5.1 (3.6)	6.1 (4.3)
Resistance p-p @ 20 °C (68 °F) ^{(5) (7)}	Ohms	R_{20}	2.256			1.128			4.51		
Inductance p-p ^{(5) (7)}	mH	L	21.6			10.8			43.0		
Magnetic attraction ⁽⁸⁾	N (lbf)	F_a	393 (88)			786 (177)					

(1) Coils at maximum temperature, 130 °C (266 °F), mounted to an aluminum heat sink whose area is noted in table on [page 149](#), and at 40 °C (104 °F) ambient.

(2) Continuous force and current based on coil moving with all phases sharing the same load in sinusoidal commutation.

(3) For standstill conditions, multiply continuous force and continuous current by 0.9.

(4) Calculated at 20% duty cycle for 1.0 second, max. Some applications can produce significantly higher peak forces. Call Applications Engineering (631.344.6600) for details.

(5) Winding parameters listed are measured line-to-line (phase-to-phase).

(6) Currents and voltages listed are measured 0-peak of the sine wave unless noted as rms.

(7) Specifications are ±10%. Phase-to-phase inductance is ±30%.

(8) All specifications are at the standard reference air gap as shown in the drawing on [page 151](#) and [page 153](#).

Kinetix LDC Iron Core Linear Motors (50 mm frame size)

Attribute	Units	Symbol	LDC-C050100-DxTxx			LDC-C050200-DxTxx			LDC-C050300-DxTxx			LDC-C050300-ExTxx					
			NC	AC	WC	NC	AC	WC	NC	AC	WC	NC	AC	WC			
Force, continuous (1) (2) (3)	N (lbf)	F_c	119 (27)	149 (34)	179 (40)	240 (54)	299 (67)	359 (81)	240 (54)	299 (67)	359 (81)	363 (82)	453 (102)	544 (122)	363 (82)	453 (102)	544 (122)
Force, peak (4)	N (lbf)	F_p	302 (68)			600 (135)						941 (212)					
Thermal resistance	°C/W	R_{th}	1.44	0.92	0.64	0.71	0.46	0.32	0.71	0.46	0.32	0.48	0.31	0.21	0.48	0.31	0.21
Force constant (5) (6) (7)	N/A _{pk} (lbf/A _{pk})	K_f	30.3 (6.8)			30.3 (6.8)			60.7 (13.6)			30.8 (6.9)			92.4 (20.8)		
Back EMF constant p-p (5) (6) (7)	V _p /m/s (V _p /in/s)	K_e	35.8 (0.91)			35.8 (0.91)			71.7 (1.82)			36.4 (0.92)			109.1 (2.77)		
Current, peak (4) (6)	A _{pk} (A _{rms})	I_p	11.7 (8.3)			23.3 (16.5)			11.6 (8.2)			35.9 (25.4)			72.0 (8.5)		
Current, continuous (1) (2) (3) (6)	A _{pk} (A _{rms})	I_c	3.9 (2.8)	4.9 (3.5)	5.9 (4.2)	7.9 (5.6)	9.9 (7.0)	11.8 (8.4)	3.9 (2.8)	4.9 (3.5)	5.9 (4.2)	11.8 (8.3)	14.7 (10.4)	17.7 (12.5)	3.9 (2.8)	4.9 (3.5)	5.9 (4.2)
Resistance p-p @ 20 °C (68 °F) (5) (7)	Ωhms	R_{20}	3.76			1.88			7.52			1.25			11.28		
Inductance p-p (5) (7)	mH	L	36			18			72			12			108		
Magnetic attraction (8)	N (lbf)	F_a	690 (155)			1379 (310)						2069 (465)					

(1) Coils at maximum temperature, 130 °C (266 °F), mounted to an aluminum heat sink whose area is noted in table on [page 149](#), and at 40 °C (104 °F) ambient.

(2) Continuous force and current based on coil moving with all phases sharing the same load in sinusoidal commutation.

(3) For standstill conditions, multiply continuous force and continuous current by 0.9.

(4) Calculated at 20% duty cycle for 1.0 second, max. Some applications can produce significantly higher peak forces. Call Applications Engineering (631.344.6600) for details.

(5) Winding parameters listed are measured line-to-line (phase-to-phase).

(6) Currents and voltages listed are measured 0-peak of the sine wave unless noted as rms.

(7) Specifications are ±10%. Phase-to-phase inductance is ±30%.

(8) All specifications are at the standard reference air gap as shown in the drawing on [page 151](#) and [page 153](#).

Kinetix LDC Iron Core Linear Motors (75 mm frame size)

Attribute	Units	Symbol	LDC-C075200-DxTxx			LDC-C075200-ExTxx			LDC-C075300-DxTxx			LDC-C075300-ExTxx			LDC-C075400-DxTxx			LDC-C075400-ExTxx		
			NC	AC	WC	NC	AC	WC	NC	AC	WC	NC	AC	WC	NC	AC	WC	NC	AC	WC
Force, continuous (1) (2) (3)	N (lbf)	F_c	348 (78)	435 (98)	523 (117)	348 (78)	435 (98)	523 (117)	523 (117)	784 (176)	871 (196)	523 (117)	784 (176)	871 (196)	1045 (235)	687 (157)	871 (196)	1045 (235)	687 (157)	871 (196)
Force, peak (4)	N (lbf)	F_p	882 (198)			1368 (308)			1368 (308)			1824 (410)								
Thermal resistance	$^{\circ}\text{C}/\text{W}$	R_{th}	0.58	0.37	0.26	0.58	0.37	0.26	0.39	0.25	0.17	0.39	0.25	0.17	0.29	0.19	0.13	0.29	0.19	0.13
Force constant (5) (6) (7)	N/A_{pk} (lbf/A_{pk})	K_f	45.5 (10.2)			91.0 (20.5)			45.5 (10.2)			136.5 (30.7)			45.5 (10.2)			91.0 (20.5)		
Back EMF constant p-p (5) (6) (7)	$V_p/\text{m/s}$ ($V_p/\text{m/s}$)	K_e	53.7 (1.37)			107.5 (2.73)			53.7 (1.37)			161.2 (4.10)			53.7 (1.37)			107.5 (2.73)		
Current, peak (4) (6)	A_{pk} (A_{rms})	I_p	22.9 (16.2)			11.5 (8.1)			35.6 (25.1)			11.9 (8.4)			47.4 (33.5)			23.7 (16.8)		
Current, continuous (1) (2) (3) (6)	A_{pk} (A_{rms})	I_c	7.7 (5.4)	9.6 (6.8)	11.5 (8.1)	3.8 (2.7)	4.8 (3.4)	5.7 (4.1)	11.5 (8.1)	14.4 (10.2)	17.2 (12.2)	3.8 (2.7)	4.8 (3.4)	5.7 (4.1)	15.3 (10.8)	19.1 (13.5)	23.0 (16.2)	7.7 (5.4)	9.6 (6.8)	11.5 (8.1)
Resistance p-p @ 20 $^{\circ}\text{C}$ (68 $^{\circ}\text{F}$) (5) (7)	Ohms	R_{20}	2.47			9.88			1.65			14.82			1.24			4.94		
Inductance p-p (5) (7)	mH	L	24			95			16			142			12			47		
Magnetic attraction (6)	N (lbf)	F_a	2000 (450)			2989 (674)			2989 (674)			3989 (899)			3989 (899)					

(1) Coils at maximum temperature, 130 $^{\circ}\text{C}$ (266 $^{\circ}\text{F}$), mounted to an aluminum heat sink whose area is noted in table on [page 149](#), and at 40 $^{\circ}\text{C}$ (104 $^{\circ}\text{F}$) ambient.

(2) Continuous force and current based on coil moving with all phases sharing the same load in sinusoidal commutation.

(3) For standstill conditions, multiply continuous force and continuous current by 0.9.

(4) Calculated at 20% duty cycle for 1.0 second, max. Some applications can produce significantly higher peak forces. Call Applications Engineering (631.344.6600) for details.

(5) Winding parameters listed are measured line-to-line (phase-to-phase).

(6) Currents and voltages listed are measured 0-peak of the sine wave unless noted as rms.

(7) Specifications are $\pm 10\%$. Phase-to-phase inductance is $\pm 30\%$.

(8) All specifications are at the standard reference air gap as shown in the drawing on [page 151](#) and [page 153](#).

Kinetix LDC Iron Core Linear Motors (100 mm frame size)

Attribute	Units	Symbol	LDC-C100300-DxTxx			LDC-C100300-ExTxx			LDC-C100400-DxTxx			LDC-C100400-ExTxx			LDC-C100600-DxTxx			LDC-C100600-ExTxx		
			NC	AC	WC	NC	AC	WC	NC	AC	WC	NC	AC	WC	NC	AC	WC	NC	AC	WC
Force, continuous (1) (2) (3)	N (lbf)	F_c	674 (152)	843 (190)	1012 (227)	674 (152)	843 (190)	1012 (227)	899 (202)	1124 (253)	1349 (303)	899 (202)	1124 (253)	1349 (303)	1686 (379)	2023 (455)	1349 (303)	1686 (379)	2023 (455)	
Force, peak (4)	N (lbf)	F_p	1767 (397)			2356 (530)			2356 (530)			3534 (794)								
Thermal resistance	$^{\circ}\text{C}/\text{W}$	R_{th}	0.33	0.21	0.15	0.33	0.21	0.15	0.25	0.16	0.11	0.25	0.16	0.11	0.11	0.07	0.17	0.11	0.07	
Force constant (5) (6) (7)	N/A_{pk} (lbf/A_{pk})	K_f	60.7 (13.6)			182.0 (40.9)			60.7 (13.6)			121.3 (27.3)					60.7 (13.6)			
Back EMF constant p-p (5) (6) (7)	$\text{V}_p/\text{m/s}$ ($\text{V}_p/\text{in/s}$)	K_e	71.7 (1.82)			215.0 (5.46)			71.7 (1.82)			143.3 (3.64)					71.7 (1.82)			
Current, peak (4) (6)	A_{pk} (A_{rms})	I_p	34.3 (24.2)			11.4 (8.1)			45.7 (32.3)			22.8 (16.1)					68.5 (48.4)			
Current, continuous (1) (2) (3) (6)	A_{pk} (A_{rms})	I_c	11.1 (7.9)	13.9 (9.8)	16.7 (11.8)	3.7 (2.6)	4.6 (3.3)	5.6 (3.9)	14.8 (10.5)	18.5 (13.1)	22.2 (15.7)	7.4 (5.2)	9.3 (6.5)	11.1 (7.9)	27.8 (19.7)	33.3 (23.6)	22.2 (15.7)	27.8 (19.7)	33.3 (23.6)	
Resistance p-p @ 20 $^{\circ}\text{C}$ (68 $^{\circ}\text{F}$) (5) (7)	Ω ms	R_{20}	2.04			18.36			1.53			6.12					1.02			
Inductance p-p (5) (7)	mH	L	20			184			15			61					10			
Magnetic attraction (6)	N (lbf)	F_a	3930 (883)						5240 (1178)								7860 (1767)			

(1) Coils at maximum temperature, 130 $^{\circ}\text{C}$ (266 $^{\circ}\text{F}$), mounted to an aluminum heat sink whose area is noted in table on [page 149](#), and at 40 $^{\circ}\text{C}$ (104 $^{\circ}\text{F}$) ambient.

(2) Continuous force and current based on coil moving with all phases sharing the same load in sinusoidal commutation.

(3) For standstill conditions, multiply continuous force and continuous current by 0.9.

(4) Calculated at 20% duty cycle for 1.0 second, max. Some applications can produce significantly higher peak forces. Call Applications Engineering (631.344.6600) for details.

(5) Winding parameters listed are measured line-to-line (phase-to-phase).

(6) Currents and voltages listed are measured 0-peak of the sine wave unless noted as rms.

(7) Specifications are $\pm 10\%$. Phase-to-phase inductance is $\pm 30\%$.

(8) All specifications are at the standard reference air gap as shown in the drawing on [page 151](#) and [page 153](#).

Kinetix LDC Iron Core Linear Motors (150 mm frame size)

Attribute	Units	Symbol	LDC-C150400-DxTxx			LDC-C150400-ExTxx			LDC-C150600-DxTxx			LDC-C150600-ExTxx		
			NC	AC	WC	NC	AC	WC	NC	AC	WC	NC	AC	WC
Force, continuous (1) (2) (3)	N (lbf)	F _c	1281 (288)	1601 (360)	1922 (432)	1281 (288)	1601 (360)	1922 (432)	1922 (432)	2402 (540)	2882 (648)	1922 (432)	2402 (540)	2882 (648)
Force, peak (4)	N (lbf)	F _p	3498 (786)						5246 (1179)					
Thermal resistance	°C/W	R _{th}	0.20	0.13	0.09	0.20	0.13	0.09	0.13	0.09	0.06	0.13	0.09	0.06
Force constant (5) (6) (7)	N/A _{pk} (lbf/A _{pk})	K _f	91.0 (20.5)			182.0 (40.9)			91.0 (20.5)			182.0 (40.9)		
Back EMF constant p-p (5) (6) (7)	V _p /m/s (V _p /in/s)	K _e	107.5 (2.73)			215.0 (5.46)			107.5 (2.73)			215.0 (5.46)		
Current, peak (4) (6)	A _{pk} (A rms)	I _p	45.2 (32.0)			22.6 (16.0)			67.8 (47.9)			33.9 (24.0)		
Current, continuous (1) (2) (3) (6)	A _{pk} (A rms)	I _c	14.1 (10.0)	17.6 (12.4)	21.1 (14.9)	7.0 (5.0)	8.8 (6.2)	10.6 (7.5)	21.1 (14.9)	26.4 (18.7)	31.7 (22.4)	10.6 (7.5)	13.2 (9.3)	15.8 (11.2)
Resistance p-p @ 20 °C (68 °F) (5) (7)	Ohms	R ₂₀	2.12			8.48			1.41			5.65		
Inductance p-p (5) (7)	mH	L	22			86			14			58		
Magnetic attraction (8)	N (lbf)	F _a	7860 (1768)						11790 (2652)					

(1) Coils at maximum temperature, 130 °C (266 °F), mounted to an aluminum heat sink whose area is noted in table on [page 149](#), and at 40 °C (104 °F) ambient.

(2) Continuous force and current based on coil moving with all phases sharing the same load in sinusoidal commutation.

(3) For standstill conditions, multiply continuous force and continuous current by 0.9.

(4) Calculated at 20% duty cycle for 1.0 second, max. Some applications can produce significantly higher peak forces. Call Applications Engineering (631.344.6600) for details.

(5) Winding parameters listed are measured line-to-line (phase-to-phase).

(6) Currents and voltages listed are measured 0-peak of the sine wave unless noted as rms.

(7) Specifications are ±10%. Phase-to-phase inductance is ±30%.

(8) All specifications are at the standard reference air gap as shown in the drawing on [page 151](#) and [page 153](#).

Weight Specifications

Motor Coil with Flying Leads and Cooling Plate

Coil Cat. No.	Weight, approx kg (lb)
LDC-C030100-DHT20	1.41 (3.1)
LDC-C030200-xHT20	2.27 (5.0)
LDC-C050100-DHT20	2.05 (4.5)
LDC-C050200-xHT20	3.18 (7.0)
LDC-C050300-xHT20	4.55 (10.0)
LDC-C075200-xHT20	4.55 (10.0)
LDC-C075300-xHT20	6.36 (14.0)
LDC-C075400-xHT20	8.18 (18.0)
LDC-C100300-xHT20	7.73 (17.0)
LDC-C100400-xHT20	10.0 (22.0)
LDC-C100600-xHT20	15.45 (34.0)
LDC-C150400-xHT20	14.55 (32.0)
LDC-C150600-xHT20	21.36 (47.0)

Cooling Plate Cat. No.	Weight, approx kg (lb)
LDC-030-100-CP	0.12 (0.26)
LDC-030-200-CP	0.20 (0.44)
LDC-050-100-CP	0.15 (0.32)
LDC-050-200-CP	0.25 (0.55)
LDC-050-300-CP	0.36 (0.79)
LDC-075-200-CP	0.39 (0.85)
LDC-075-300-CP	0.56 (1.23)
LDC-075-400-CP	0.73 (1.60)
LDC-100-300-CP	0.73 (1.60)
LDC-100-400-CP	0.96 (2.10)
LDC-100-600-CP	1.39 (3.05)
LDC-150-400-CP	1.93 (4.24)
LDC-150-600-CP	2.86 (6.29)

Coil and Cooling Plate (combined) Weight, approx kg (lb)
1.53 (3.4)
2.47 (5.4)
2.19 (4.8)
3.43 (7.6)
4.91 (10.8)
4.93 (10.9)
6.92 (15.2)
8.91 (19.6)
8.46 (18.6)
10.96 (24.1)
16.84 (37.0)
16.47 (36.2)
24.22 (53.3)

Motor Coil with Connectors and Cooling Plate

Coil Cat. No.	Weight, approx kg (lb)
LDC-C030100-DHT11	1.61 (3.55)
LDC-C030200-xHT11	2.47 (5.44)
LDC-C050100-DHT11	2.25 (4.96)
LDC-C050200-xHT11	3.38 (7.45)
LDC-C050300-xHT11	4.75 (10.47)
LDC-C075200-xHT11	4.75 (10.47)
LDC-C075300-xHT11	6.56 (14.46)
LDC-C075400-xHT11	8.38 (18.47)
LDC-C100300-xHT11	7.91 (17.4)
LDC-C100400-xHT11	10.2 (22.5)
LDC-C100600-xHT11	15.65 (34.5)
LDC-C150400-xHT11	14.75 (32.5)
LDC-C150600-xHT11	21.56 (47.5)

Cooling Plate Cat. No.	Weight, approx kg (lb)
LDC-030-100-CP	0.12 (0.26)
LDC-030-200-CP	0.20 (0.44)
LDC-050-100-CP	0.15 (0.32)
LDC-050-200-CP	0.25 (0.55)
LDC-050-300-CP	0.36 (0.79)
LDC-075-200-CP	0.39 (0.85)
LDC-075-300-CP	0.56 (1.23)
LDC-075-400-CP	0.73 (1.60)
LDC-100-300-CP	0.73 (1.60)
LDC-100-400-CP	0.96 (2.10)
LDC-100-600-CP	1.39 (3.05)
LDC-150-400-CP	1.93 (4.24)
LDC-150-600-CP	2.86 (6.29)

Coil and Cooling Plate (combined) Weight, approx kg (lb)
1.73 (3.81)
2.67 (5.89)
2.40 (5.29)
3.63 (8.00)
5.11 (11.3)
5.14 (11.33)
7.12 (15.70)
9.11 (20.08)
8.64 (18.6)
11.16 (24.60)
17.04 (37.57)
16.19 (35.69)
23.69 (52.23)

Motor Magnet Track

Magnet Track Cat. No.	Weight, approx kg (lb)
LDC-M030100	0.47 (1.02)
LDC-M050100	0.66 (1.46)
LDC-M075100	0.90 (1.98)
LDC-M100100	1.14 (2.51)
LDC-M150100	1.62 (3.57)
LDC-M030500	2.35 (5.12)
LDC-M050500	3.32 (7.28)
LDC-M075500	4.5 (9.92)
LDC-M100500	5.7 (12.57)
LDC-M150500	8.08 (17.81)

Carriage Weight and Heat Sink Area Requirements

Cat. No.	Required Heat Sink Area cm² (in.²)	Required Carriage Plate Weight, approx kg (lb)
LDC-C030100-DHTxx	150 X 200 (6 X 8)	1.1 (2.6)
LDC-C030200-xHTxx	150 X 300 (6 X 12)	1.6 (3.6)
LDC-C050100-DHTxx	200 X 200 (8 X 8)	1.8 (4)
LDC-C050200-xHTxx	200 X 300 (8 X 12)	2.7 (6)
LDC-C050300-xHTxx	200 X 400 (8 X 16)	3.6 (8)
LDC-C075200-xHTxx	250 X 300 (10 X 12)	5.4 (12)
LDC-C075300-xHTxx	250 X 400 (10 X 16)	7.3 (16)
LDC-C075400-xHTxx	250 X 500 (10 X 20)	9.1 (20)
LDC-C100300-xHTxx	300 X 400 (12 X 16)	8.7 (19.2)
LDC-C100400-xHTxx	300 X 500 (12 X 20)	10.9 (24)
LDC-C100600-xHTxx	300 X 750 (12 X 30)	19.6 (43.2)
LDC-C150400-xHTxx	400 X 500 (16 X 20)	21.8 (48)
LDC-C150600-xHTxx	400 X 750 (16 X 30)	32.7 (72)

Cooling Plate Flow Rate Specifications

Coil Cat. No.	Cooling Plate Cat. No.	Air Flow Rate ⁽¹⁾ L/min (ft ³ /hr)	Water Flow Rate ⁽²⁾ bar (psi)
LDC-C030100-xxxxx	LDC-030-100-CP	N/A ⁽³⁾	N/A ⁽³⁾
LDC-C030200-xxxxx	LDC-030-200-CP	N/A ⁽³⁾	N/A ⁽³⁾
LDC-C050100-xxxxx	LCC-050-100-CP	N/A ⁽³⁾	0.41 (6)
LDC-C050200-xxxxx	LDC-050-200-CP	N/A ⁽³⁾	0.48 (7)
LDC-C050300-xxxxx	LCC-050-300-CP	N/A ⁽³⁾	0.55 (8)
LDC-C075200-xxxxx	LDC-075-200-CP	N/A ⁽³⁾	0.48 (7)
LDC-C075300-xxxxx	LDC-075-300-CP	N/A ⁽³⁾	0.55 (8)
LDC-C075400-xxxxx	LDC-075-400-CP	N/A ⁽³⁾	0.69 (10)
LDC-C100300-xxxxx	LDC-100-300-CP	61.4 (130)	0.69 (10)
LDC-C100400-xxxxx	LDC-100-400-CP	N/A ⁽³⁾	0.83 (12)
LDC-C100600-xxxxx	LDC-100-600-CP	47.2 (100)	0.97 (14)
LDC-C150400-xxxxx	LDC-150-400-CP	N/A ⁽³⁾	0.83 (12) ⁽⁴⁾
LDC-C150600-xxxxx	LDC-150-600-CP	N/A ⁽³⁾	0.93 (13.5) ⁽⁴⁾

(1) These are the flow rates required to maintain air pressure at 0.689 bar (10 lb/in.²).

(2) These are the flow rates required to maintain water pressure at 3.8 L/min (1 gal/min).

(3) This flow rate is not available. Call Application Engineering (631-344-6600) for assistance.

(4) These are the flow rates required to maintain water pressure at 7.57 L/min (2 gal/min).

Dimensions - Kinetix LDC Iron Core Linear Motors

Kinetix LDC iron core linear motor components are designed to metric dimensions. Inch dimensions are conversions from millimeters. Untoleranced dimensions are for reference.

LDC-C030/050/075/100xxx-xHT20 Motor Coil Dimensions (Flying leads)

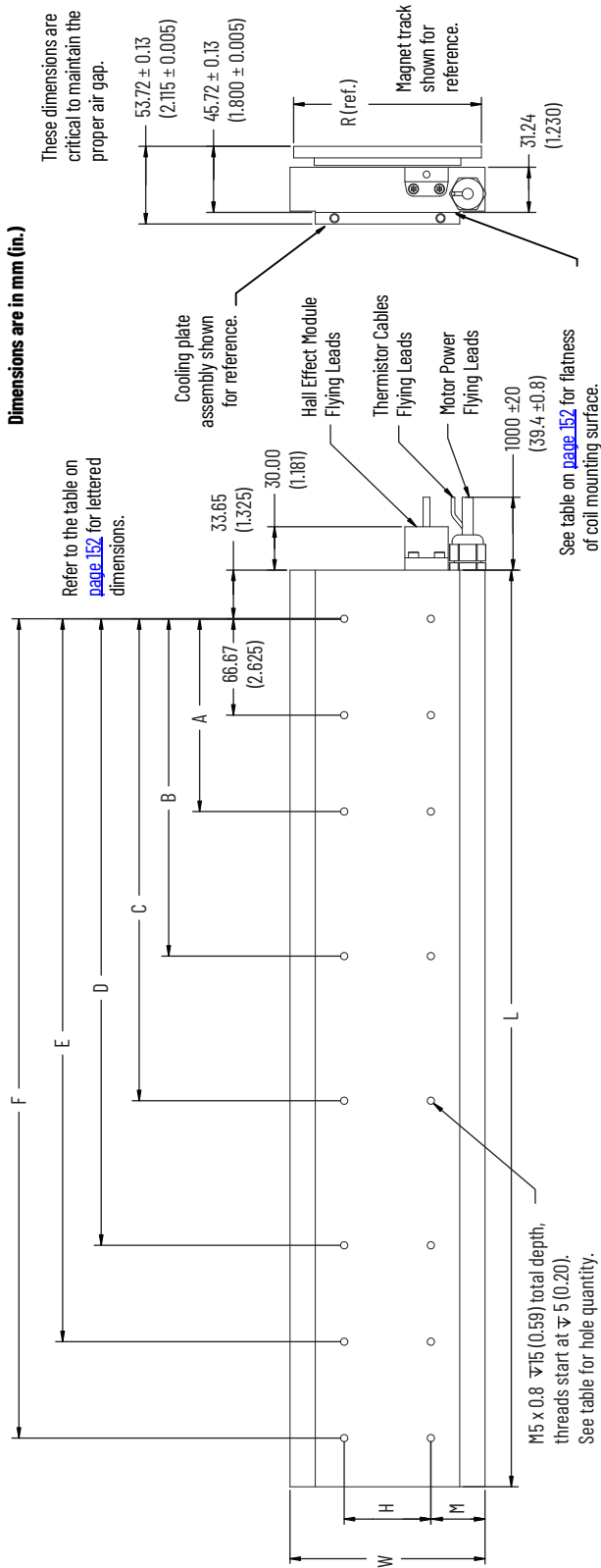

LDC-C030/050/075/100xxx-xHT11 Motor Coil Dimensions (connectors)

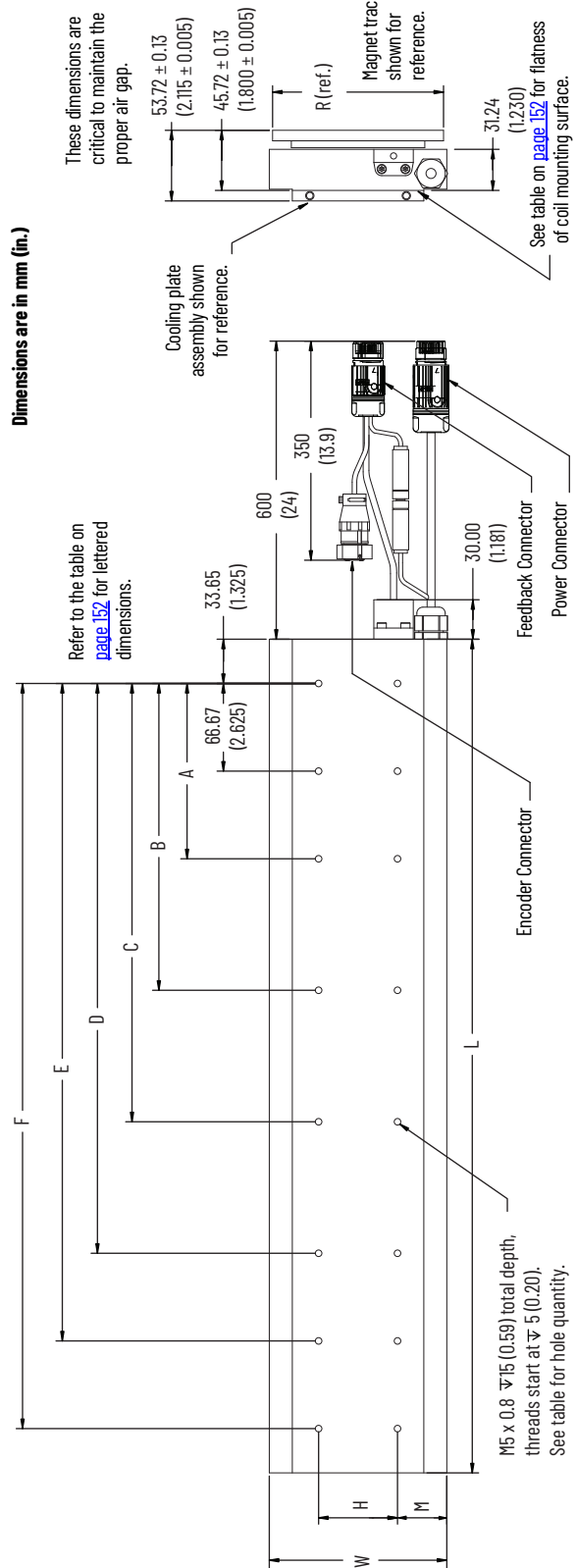

LDC-C030/050/075/100xxx-xHTxx Motor Coil Dimensions

Cat. No.	L mm (in.)	W (1) mm (in.)	A mm (in.)	B mm (in.)	C mm (in.)	D mm (in.)	E mm (in.)	F mm (in.)	H mm (in.)	M mm (in.)	R mm (in.)	Hole Qty
LDC-C030100-DHTxx	134.0 (5.28)	65.00 (2.559)	-	-	-	-	-	-	15.00 (0.591)	25.00 (0.984)	60.00 (2.362)	4
LDC-C030200-xHTxx	234.0 (9.21)	-	100.00 (3.937)	166.67 (6.562)	-	-	-	-	-	-	-	8
LDC-C050100-DHTxx	134.0 (5.28)	85.00 (3.346)	-	-	-	-	-	-	25.00 (0.984)	30.00 (1.181)	80.00 (3.150)	4
LDC-C050200-xHTxx	234.0 (9.21)	-	100.00 (3.937)	166.67 (6.562)	-	-	-	-	-	-	-	8
LDC-C050300-xHTxx	334.0 (13.15)	-	133.33 (5.249)	200.00 (7.874)	266.67 (10.499)	-	-	-	-	-	-	10
LDC-C075200-xHTxx	234.0 (9.21)	110.00 (4.331)	100.00 (3.937)	166.67 (6.562)	-	-	-	-	-	-	-	8
LDC-C075300-xHTxx	334.0 (13.15)	-	133.33 (5.249)	200.00 (7.874)	266.67 (10.499)	-	-	-	40.00 (1.575)	35.00 (1.378)	105.00 (4.134)	10
LDC-C075400-xHTxx	434.0 (17.09)	-	133.33 (5.249)	233.33 (9.186)	300.00 (11.811)	366.67 (14.436)	-	-	-	-	-	12
LDC-C100300-xHTxx	334.0 (13.15)	135.00 (5.315)	133.33 (5.249)	200.00 (7.874)	266.67 (10.499)	-	-	-	-	-	-	10
LDC-C100400-xHTxx	434.0 (17.09)	-	133.33 (5.249)	233.33 (9.186)	300.00 (11.811)	366.67 (14.436)	-	-	60.00 (2.362)	37.50 (1.476)	130.00 (5.118)	12
LDC-C100600-xHTxx	634.0 (25.31)	-	133.33 (5.249)	233.33 (9.186)	333.33 (13.123)	433.33 (17.060)	500.00 (19.686)	566.66 (22.310)	-	-	-	16

(1) Tolerance for W dimension is +1.00 mm (+0.039 in.), -0.00 mm (-0.000 in.)

Cat. No.	Power Cable Gauge (1) mm ² (AWG)	Cat. No.	Flatness mm/300 x 300 (in./12 x 12)
LDC-C030xxx-xHTxx		LDC-C030xxx-xHTxx	
LDC-C050xxx-xHTxx		LDC-C050100-DHTxx	0.25 (0.01)
LDC-C075xxx-xHTxx	0.75 (18)	LDC-C050200-xHTxx	
LDC-C100300-xHTxx		LDC-C050300-xHTxx	0.38 (0.15)
LDC-C100400-xHTxx		LDC-C075200-xHTxx	0.25 (0.01)
LDC-C100600-DHTxx	1.5 (16)	LDC-C075300-xHTxx	0.38 (0.15)
LDC-C100600-EHTxx	0.75 (18)	LDC-C075400-xHTxx	0.64 (0.25)
		LDC-C100300-xHTxx	0.38 (0.15)
		LDC-C100400-xHTxx	0.64 (0.25)
		LDC-C100600-xHTxx	0.89 (0.035)

(1) Refer to Cable Specifications on page 154 for additional cable specifications.

LDC-C0150xxx-xHT20 Motor Coil Dimensions (Flying leads)

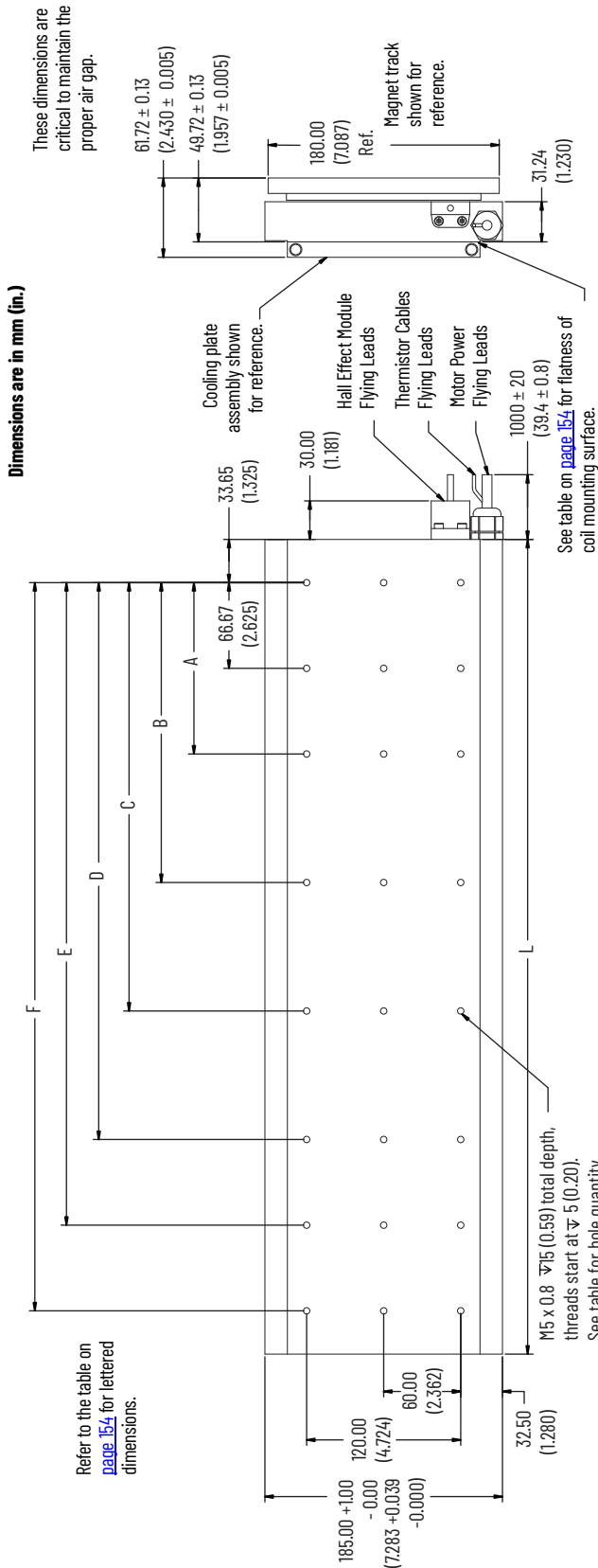

LDC-C150xxx-xHT11 Motor Coil Dimensions (connectors)

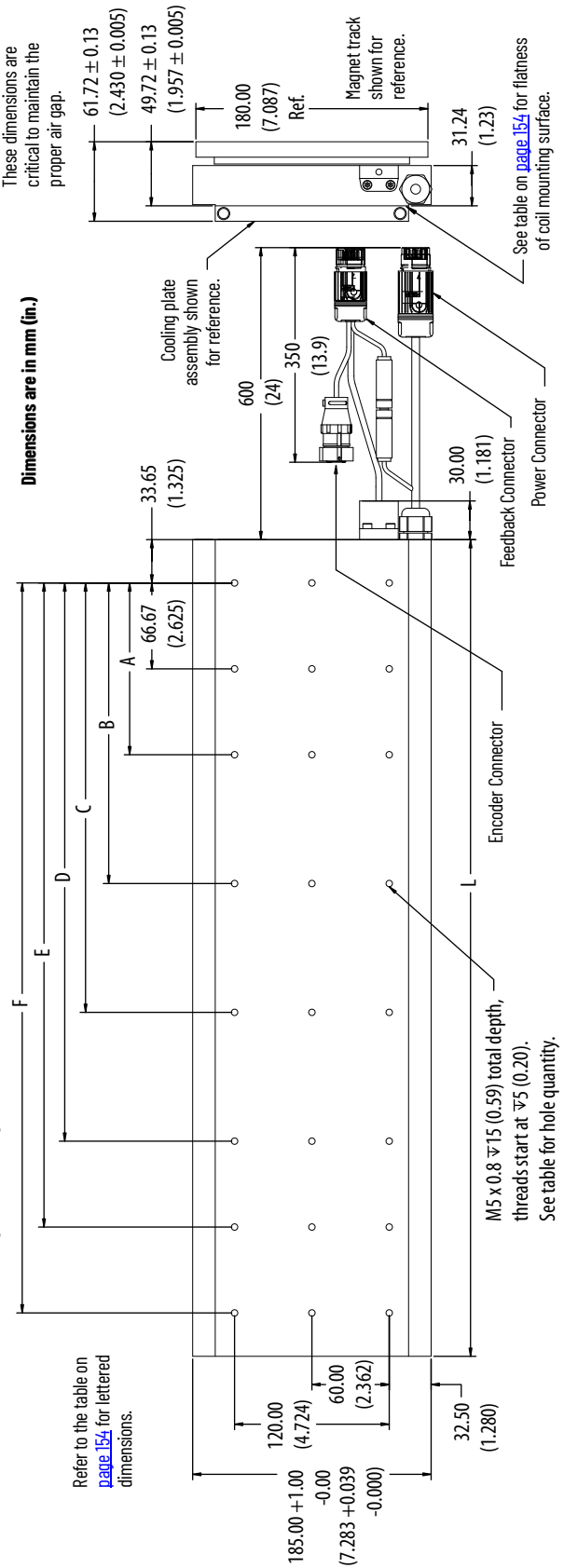

LDC-C150xxx-xHTxx Motor Coil Dimensions

Cat. No.	L mm (in.)	A mm (in.)	B mm (in.)	C mm (in.)	D mm (in.)	E mm (in.)	F mm (in.)	Hole Qty
LDC-C150400-xHTxx	434.0 (17.09)	133.33 (5.249)	233.33 (9.186)	300.00 (11.811)	366.67 (14.436)	-	-	18
LDC-C150600-xHTxx	634.0 (25.31)	133.33 (5.249)	233.33 (9.186)	333.33 (13.123)	433.33 (17.060)	500.00 (19.686)	566.66 (22.310)	24

Cable Specifications

Cable (1)	Conductors	Gauge mm ² (AWG)	Shield Type	Cable Dia. mm (in.)	Static Bend Radius mm (in.)
Power (2)	4	0.75 (18)	Braid	7.0 (0.28)	18.0 (0.70)
Power (2)	4	1.5 (16)	Braid	8.0 (0.32)	17.0 (0.67)
Power (2)	4	0.50 (20)	Braid	6.4 (0.25)	17.0 (0.67)
Thermistor	2	0.14 (26)	None	4.0 (0.16)	10.0 (0.40)
Hall Module	6	0.25 (24)	Foil	5.0 (0.20)	15.0 (0.59)

(1) All cables are non-flex.

(2) Power cable specification is dependent on coil used. See Power Cable Gauge tables on [page 152](#) and [page 154](#).

Cat. No.	Power Cable Gauge mm ² (AWG)	Flatness mm/300 x 300 (in./12 x 12)
LDC-C150400-xHTxx	0.82 (18)	0.64 (0.025)
LDC-C150600-DHTxx		
LDC-C150600-EHTxx	1.31 (16)	0.89 (0.035)

Kinetix LDC Iron Core Linear Motor Magnet Track Dimensions

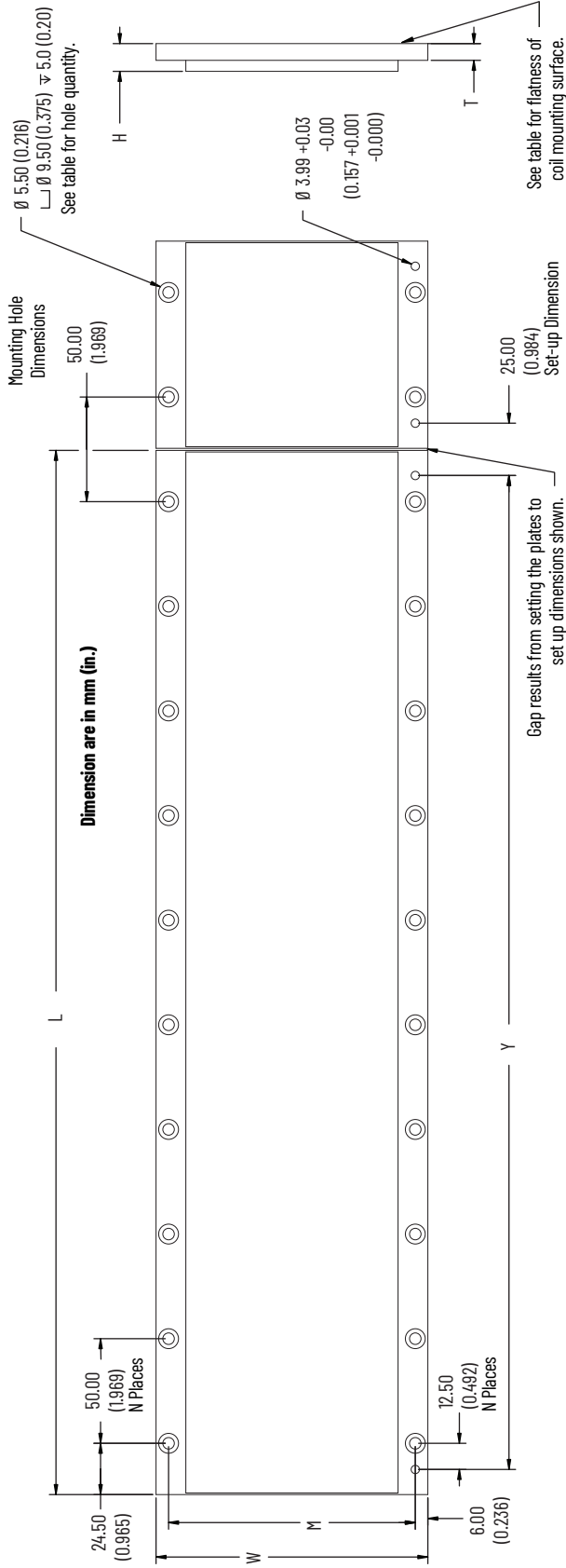

Cat. No.	L (1) mm (in.)	Y (2) mm (in.)	W mm (in.)	M mm (in.)	H (3) mm (in.)	T mm (in.)	N	Hole Ø/ty	Flatness (4) mm/300 x 300 (in./12 x 12)
LDC-M030100			60.0 (2.36)	48.00 (1.890)					0.06 (0.002)
LDC-M050100			80.0 (3.15)	68.00 (2.677)	13.26 (0.522)	8.00 (0.315)	1	4	
LDC-M075100		75.00 (2.953)	105.0 (4.13)	93.00 (3.661)					0.13 (0.005)
LDC-M100100			130.0 (5.12)	118.00 (4.646)					
LDC-M150100			180.0 (7.09)	168.00 (6.614)	17.26 (0.680)	12.00 (0.472)			0.50 (0.20)
LDC-M030500			60.0 (2.36)	48.00 (1.890)					
LDC-M050500			80.0 (3.15)	68.00 (2.677)	13.26 (0.522)	8.00 (0.315)	9	20	
LDC-M075500		475.00 (18.70)	105.0 (4.13)	93.00 (3.661)					0.90 (0.035)
LDC-M100500			130.0 (5.12)	118.00 (4.646)					
LDC-M150500			180.0 (7.09)	168.00 (6.614)	17.26 (0.680)	12.00 (0.472)			

(1) Tolerance for L dimension is ± 0.25 mm (± 0.010 in.).
 (2) Tolerance for Y dimension is ± 0.08 mm (± 0.003 in.).
 (3) Tolerance for H dimension is ± 0.16 mm (± 0.006 in.).
 (4) Specified flatness is in the free state.

LDC-030/050/075/100-xxx-CP Motor Coil Cooling Plate Dimensions

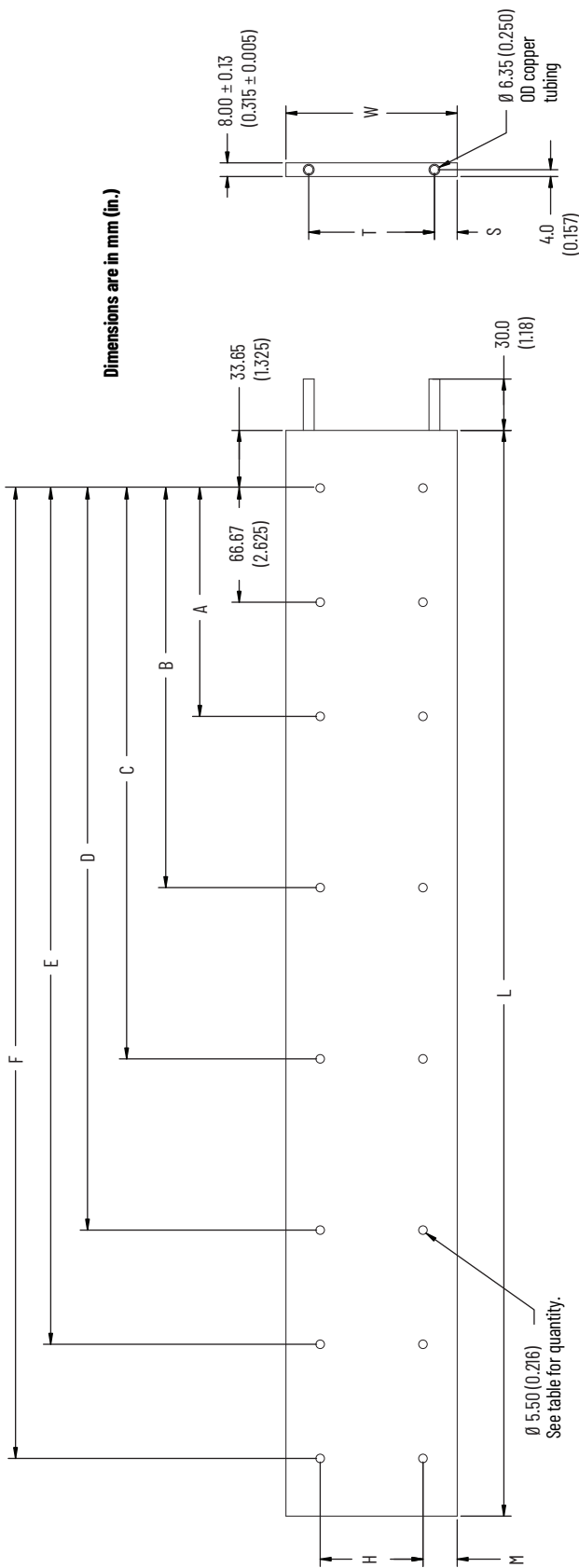

Cat. No.	L mm (in.)	W mm (in.)	A mm (in.)	B mm (in.)	C mm (in.)	D mm (in.)	E mm (in.)	F mm (in.)	H mm (in.)	M mm (in.)	T mm (in.)	S mm (in.)	Hole Qty
LDC-030-100-CP	134.0 (5.28)	38.00 (1.496)	-	-	-	-	-	-	15.00 (0.591)	11.50 (0.453)	27.5 (1.08)	5.25 (0.207)	4
LDC-030-200-CP	234.0 (9.21)	-	100.00 (3.937)	166.67 (6.562)	-	-	-	-	-	-	-	-	8
LDC-050-100-CP	134.0 (5.28)	50.00 (1.969)	-	-	-	-	-	-	25.00 (0.984)	12.50 (0.492)	38.1 (1.50)	5.95 (0.234)	4
LDC-050-200-CP	234.0 (9.21)	-	100.00 (3.937)	166.67 (6.562)	-	-	-	-	-	-	-	-	8
LDC-050-300-CP	334.0 (13.15)	-	133.33 (5.249)	200.00 (7.874)	266.67 (10.499)	-	-	-	-	-	-	-	10
LDC-075-200-CP	234.0 (9.21)	75.00 (2.953)	100.00 (3.937)	166.67 (6.562)	-	-	-	-	40.00 (1.575)	17.50 (0.689)	50.8 (2.00)	12.10 (0.476)	8
LDC-075-300-CP	334.0 (13.15)	-	133.33 (5.249)	200.00 (7.874)	266.67 (10.499)	-	-	-	-	-	-	-	10
LDC-075-400-CP	434.0 (17.09)	-	133.33 (5.249)	233.33 (9.186)	300.00 (11.811)	366.67 (14.436)	-	-	-	-	-	-	12
LDC-100-300-CP	334.0 (13.15)	100.00 (3.937)	133.33 (5.249)	200.00 (7.874)	266.67 (10.499)	-	-	-	60.00 (2.362)	20.00 (0.787)	73.4 (2.89)	13.30 (0.524)	10
LDC-100-400-CP	434.0 (17.09)	-	133.33 (5.249)	233.33 (9.186)	300.00 (11.811)	366.67 (14.436)	-	-	-	-	-	-	12
LDC-100-600-CP	634.0 (25.31)	-	133.33 (5.249)	233.33 (9.186)	333.33 (13.123)	433.33 (17.060)	500.00 (19.686)	566.66 (22.310)	-	-	-	-	16

LDC-150-xxx-CP Motor Coil Cooling Plate Dimensions

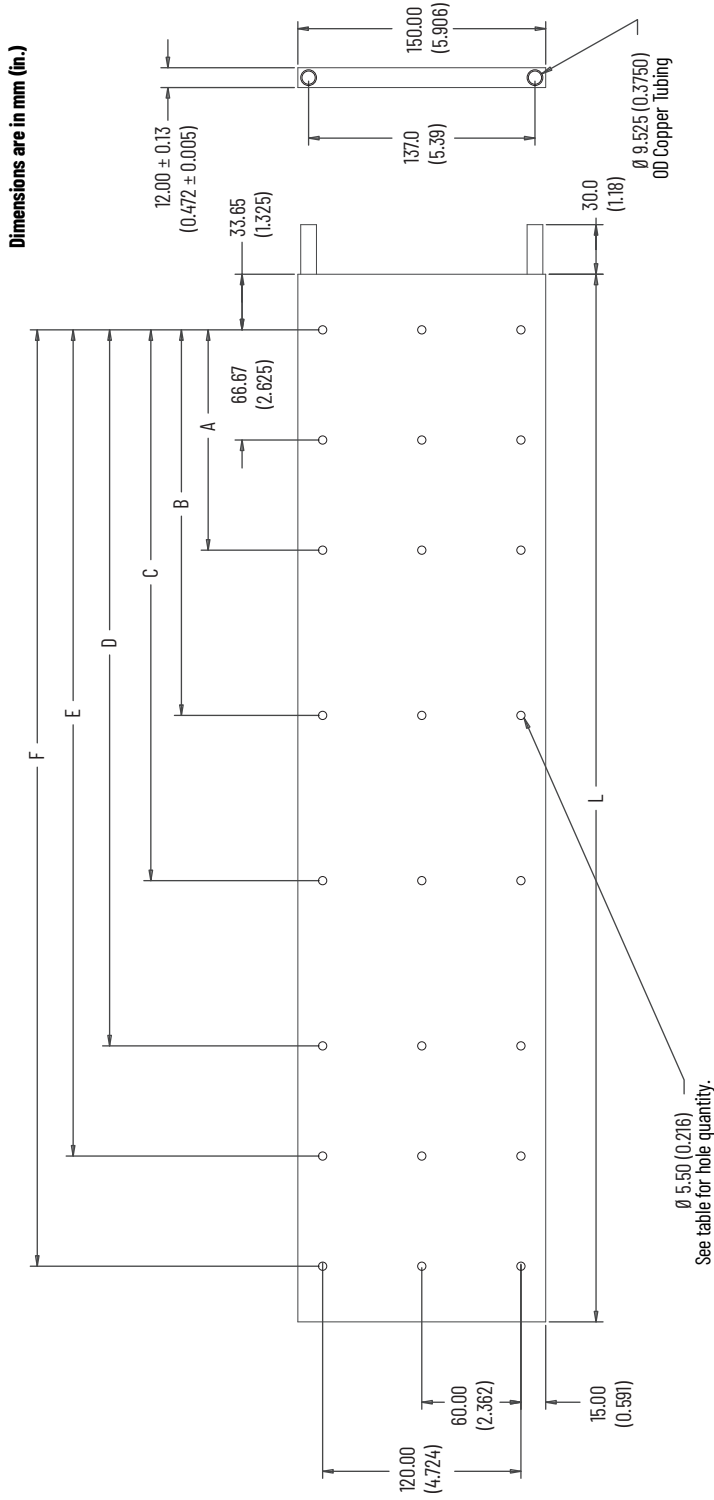

Cat. No.	L mm (in.)	A mm (in.)	B mm (in.)	C mm (in.)	D mm (in.)	E mm (in.)	F mm (in.)	Hole Qty
LDC-150-400-CP	434.0 (17.09)	133.33 (5.249)	233.33 (9.186)	300.00 (11.811)	366.67 (14.436)	-	-	18
LDC-150-600-CP	634.0 (25.31)	133.33 (5.249)	233.33 (9.186)	333.33 (13.123)	433.33 (17.060)	500.00 (19.686)	566.66 (22.310)	24

Kinetix LDL Ironless Linear Servo Motors



The Kinetix LDL ironless linear motors address a growing interest in linear motor technology as it becomes more affordable and is increasingly recognized as a practical means of improving machine performance. With the ironless product design, you now have cost-effective options to help you improve machine throughput while reducing maintenance and downtime.

Kinetix LDL Ironless Linear Motor Features

- No magnetic attraction between the coil and magnet channel allows for the use of smaller, less expensive linear bearings.
- No external magnetic field to have to shield in magnetic sensitive applications.
- Non-cogging technology for super smooth motion.
- Very high acceleration and speeds up to 10 m/s (32.8 ft/s) greatly increase the throughput of your machine.
- No limits to travel distance. Ability to achieve high speeds over short and long travels.
- Direct drive technology for extreme servo responsiveness.
- No-wear, high reliability parts increase productivity.
- Peak forces to 1977 N (444 lb).
- Ability to size and optimize Kinetix LDL ironless linear motors and corresponding servo drives by using Motion Analyzer software reduces product selection time and minimizes cost.
- Full set-up and programming support with the Studio 5000 Logix Designer application reduces set-up time.

Motor Connector/Cable Compatibility

Kinetix LDL ironless linear motors are equipped with SpeedTec-ready DIN connectors. However, these motors have incremental encoders and must use threaded DIN (M4) feedback cables in non-flex applications. This is due to the number of conductors required for incremental encoder connections.

Kinetix LDL Ironless Linear Motors

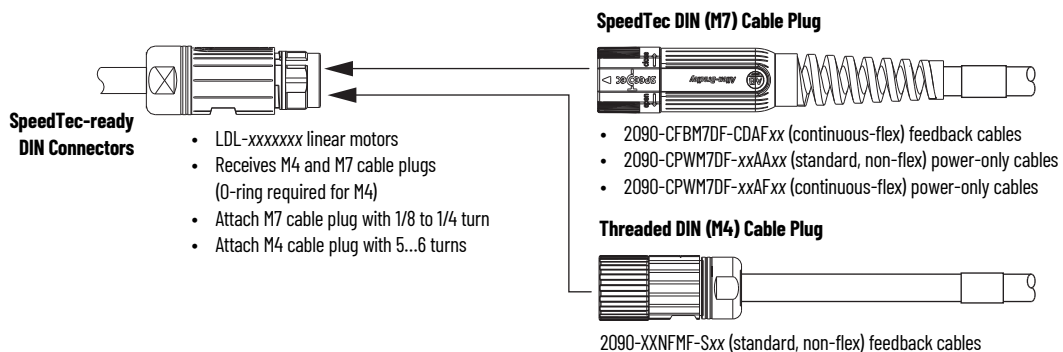

Catalog Numbers - Kinetix LDL Ironless Linear Motors

Catalog numbers consist of various characters, each of which identifies a specific option for that component. Use the catalog numbering table chart below to understand the configuration of your actuator. For questions regarding product availability, contact your Allen-Bradley distributor.

Kinetix LDL Ironless Linear Motors

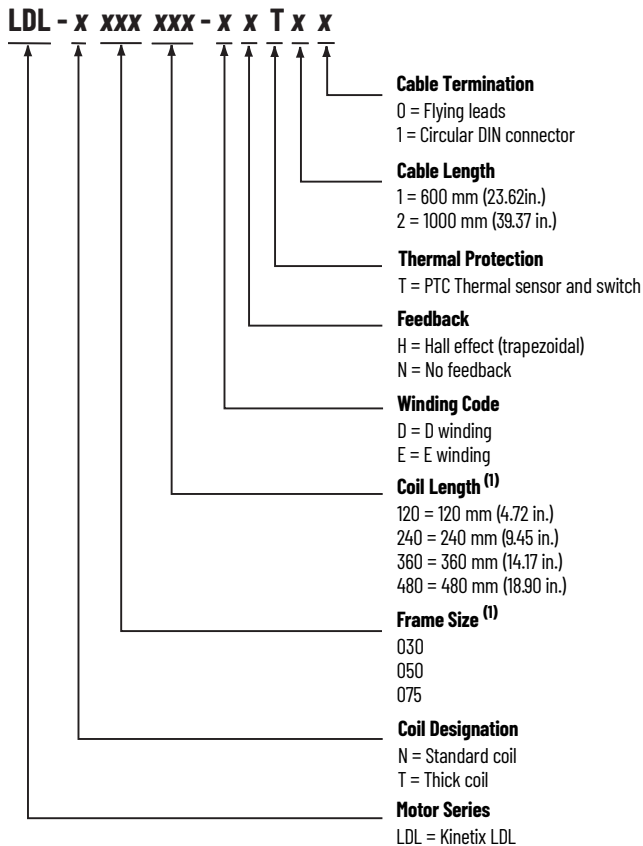

(1) Not all combinations are available. Only the configurations as listed in Technical Specifications - Kinetix LDL Ironless Linear Motors on [page 161](#) are available.

Kinetix LDL Ironless Linear Motor Magnet Channels

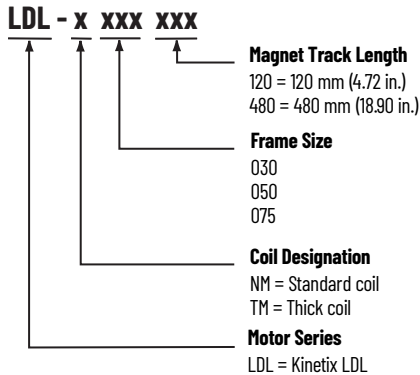

Accessories - Kinetix LDL Ironless Linear Motors

- Bulk head connector kit
- Encoder connector kit
- Hall effect replacement module for connectorized coil
- Hall effect replacement module for flying-lead coil

Accessories for Kinetix LDL Ironless Linear Motors

Cat. No.	Accessory	Description
LDC-BULK-HD	Bulk head connector kit	For easy mounting of flex cable to non-flex cables. Kit includes flange for feedback and power connectors, o-rings, and nut.
LDC-ENC-CNCT	Encoder connector kit	Adapts your encoder to the feedback cable on the Hall effect module.
LDL-HALL-C	Hall effect module	Replacement module for use with connectorized coil.
LDL-HALL-F		Replacement module for use with flying-lead coil.

Bulk Head Connector Flange Dimensions

Dimensions are in mm (in.)

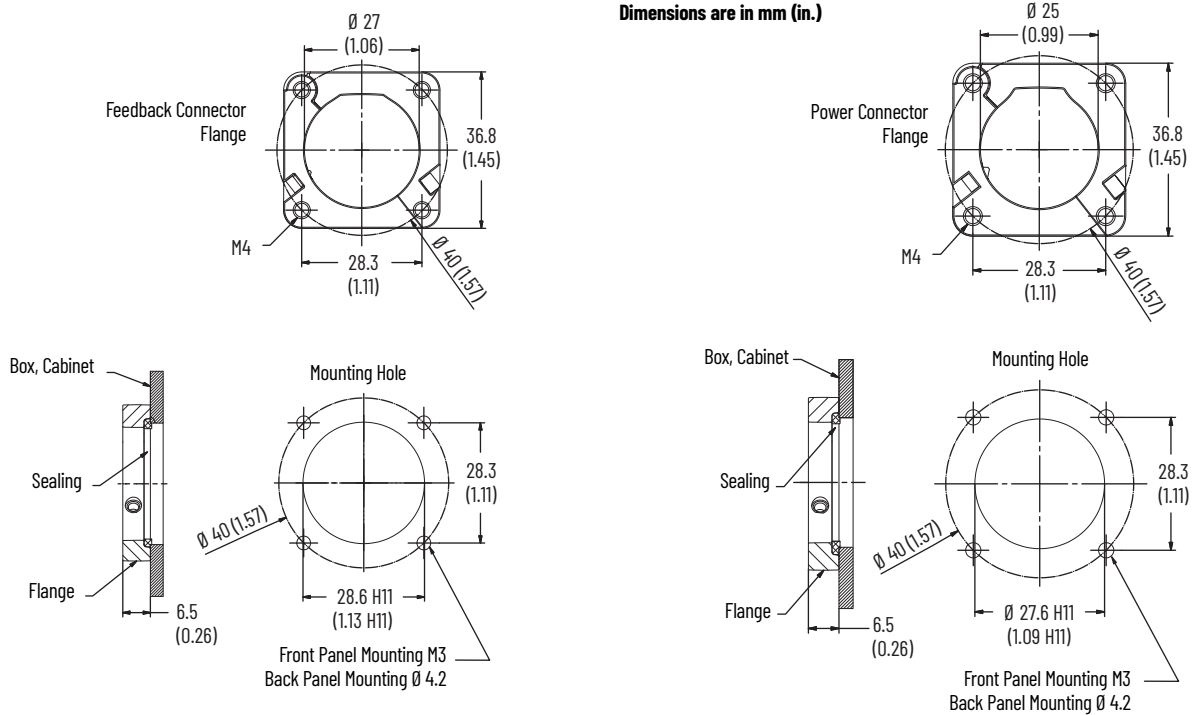

Technical Specifications - Kinetix LDL Ironless Linear Motors

These performance specifications apply to all Kinetix LDL ironless linear motors.

Common Performance Specifications

Attribute	Value
Motor type	3 phase, wye winding, synchronous permanent magnet stator, non-ventilated linear motor.
Operating speed, max	10 m/s (32.8 ft/s)
Operating voltage, (not for direct connection to AC line)	230V AC rms
Dielectric rating of motor power connections (U,V,W), to ground for 1.0 s ⁽¹⁾	1500V AC rms, 50/60 Hz
Cogging torque	Zero
Applied bus voltage, max ⁽²⁾	325V DC
Electrical cycle length	60 mm (2.36 in.)
Coil temperature, max	130 °C (266 °F)
Insulation class	130 °C (266 °F) Class B
Thermal time constant, Ref, winding to ambient	35 min
Paint color	Black

(1) Tested during manufacturing process. Do not re-apply test voltage. Contact Application Engineering (631.344.6600) for advice on testing coils post production.

(2) Maximum cable length 10 m (32.8 ft). Contact Application Engineering (631.344.6600) for applications requiring longer cables.

Kinetix LDL Ironless Linear Motor (standard 30 mm frame size)

Attribute	Units	Symbol	LDL-N030120-DxTxx	LDL-N030240-DxTxx	LDL-N030240-ExTxx
Force, continuous ⁽¹⁾ ⁽²⁾ ⁽³⁾ ⁽⁴⁾	N (lbf)	F_c	63 (14)	126 (28)	
Force, peak ⁽⁵⁾	N (lbf)	F_p	209 (47)	417 (94)	
Thermal resistance	°C/W	R_{th}	1.73	0.86	
Force constant ⁽⁶⁾ ⁽⁷⁾ ⁽⁸⁾	N/A _{pk} (lbf/A _{pk})	K_f	21.0 (4.7)	21.0 (4.7)	42.0 (9.4)
Back EMF constant p-p ⁽⁶⁾ ⁽⁷⁾ ⁽⁸⁾	V _p /m/s (V _p /in/s)	K_e	24.8 (0.6)	24.8 (0.6)	49.6 (1.3)
Current, peak ⁽⁵⁾ ⁽⁷⁾	A _{pk} (A _{rms})	I_p	9.9 (7.0)	19.9 (14.0)	9.9 (7.0)
Current, continuous ⁽¹⁾ ⁽²⁾ ⁽³⁾ ⁽⁴⁾	A _{pk} (A _{rms})	I_c	3.0 (2.1)	6.0 (4.2)	3.0 (2.1)
Resistance p-p @ 20 °C (68 °F) ⁽⁶⁾ ⁽⁸⁾	Ohms	R_{20}	5.41	2.70	10.82
Inductance p-p ⁽⁶⁾ ⁽⁸⁾	mH	L	8.43	4.22	16.86
Magnetic attraction	N (lbf)	F_a	0 (0)		

Kinetix LDL Ironless Linear Motor (thick 30 mm frame size)

Attribute	Units	Symbol	LDL-T030120-DxTxx	LDL-T030240-DxTxx	LDL-T030240-ExTxx
Force, continuous ⁽¹⁾ ⁽²⁾ ⁽³⁾ ⁽⁴⁾	N (lbf)	F_c	72 (16)	144 (32)	
Force, peak ⁽⁵⁾	N (lbf)	F_p	239 (54)	479 (108)	
Thermal resistance	°C/W	R_{th}	1.31	0.65	
Force constant ⁽⁶⁾ ⁽⁷⁾ ⁽⁸⁾	N/A _{pk} (lbf/A _{pk})	K_f	24.1 (5.4)	24.1 (5.4)	48.2 (10.8)
Back EMF constant p-p ⁽⁶⁾ ⁽⁷⁾ ⁽⁸⁾	V _p /m/s (V _p /in/s)	K_e	28.5 (0.7)	28.5 (0.7)	56.9 (1.4)
Current, peak ⁽⁵⁾ ⁽⁷⁾	A _{pk} (A _{rms})	I_p	9.9 (7.0)	19.9 (14.0)	9.9 (7.0)
Current, continuous ⁽¹⁾ ⁽²⁾ ⁽³⁾ ⁽⁴⁾	A _{pk} (A _{rms})	I_c	3.0 (2.1)	6.0 (4.2)	3.0 (2.1)
Resistance p-p @ 20 °C (68 °F) ⁽⁶⁾ ⁽⁸⁾	Ohms	R_{20}	7.15	3.57	14.29
Inductance p-p ⁽⁶⁾ ⁽⁸⁾	mH	L	13.40	6.70	26.80
Magnetic attraction	N (lbf)	F_a	0 (0)		

- (1) Coils at maximum temperature, 130 °C (266 °F), mounted to an aluminum heat sink whose area is noted in table on [page 166](#), and at 40 °C (104 °F) ambient.
- (2) Continuous force and current based on coil moving with all phases sharing the same load in sinusoidal commutation.
- (3) For standstill conditions, multiply continuous force and continuous current by 0.9.
- (4) Coil mountings on either of the two narrow sides reduces continuous force by 10%.
- (5) Calculated at 11% duty cycle for 1.0 second, max. Some applications can produce significantly higher peak forces. Call Applications Engineering (631.344.6600) for details.
- (6) Winding parameters listed are measured line-to-line (phase-to-phase).
- (7) Currents and voltages listed are measured 0-peak of the sine wave unless noted as rms.
- (8) Specifications are ±10%. Phase-to-phase inductance is ±30%.

Kinetix LDL Ironless Linear Motor (standard 50 mm frame size)

Attribute	Units	Symbol	LDL-N050120-DxTxx	LDL-N050240-DxTxx	LDL-N050240-ExTxx
Force, continuous ⁽¹⁾ ⁽²⁾ ⁽³⁾ ⁽⁴⁾	N (lbf)	F_c	96 (22)	191 (43)	
Force, peak ⁽⁵⁾	N (lbf)	F_p	317 (71)	635 (143)	
Thermal resistance	°C/W	R_{th}	1.58	0.79	
Force constant ⁽⁶⁾ ⁽⁷⁾ ⁽⁸⁾	N/A_{pk} (lbf/ A_{pk})	K_f	35.0 (7.9)	35.0 (7.9)	70.0 (15.7)
Back EMF constant p-p ⁽⁶⁾ ⁽⁷⁾ ⁽⁸⁾	$V_p/m/s$ ($V_p/in/s$)	K_e	41.3 (1.1)	41.3 (1.1)	82.7 (2.1)
Current, peak ⁽⁵⁾ ⁽⁷⁾	A_{pk} (A_{rms})	I_p	9.1 (6.4)	18.1 (12.8)	9.1 (6.4)
Current, continuous ⁽¹⁾ ⁽²⁾ ⁽³⁾ ⁽⁴⁾	A_{pk} (A_{rms})	I_c	2.7 (1.9)	5.5 (3.9)	2.7 (1.9)
Resistance p-p @ 20 °C (68 °F) ⁽⁶⁾ ⁽⁸⁾	Ohms	R_{20}	7.11	3.56	14.22
Inductance p-p ⁽⁶⁾ ⁽⁸⁾	mH	L	11.08	5.54	22.16
Magnetic attraction	N (lbf)	F_a	0 (0)		

Attribute	Units	Symbol	LDL-N050360-DxTxx	LDL-N050360-ExTxx	LDL-N050480-DxTxx	LDL-N050480-ExTxx
Force, continuous ⁽¹⁾ ⁽²⁾ ⁽³⁾ ⁽⁴⁾	N (lbf)	F_c	287 (65)		383 (86)	
Force, peak ⁽⁵⁾	N (lbf)	F_p	952 (214)		1269 (285)	
Thermal resistance	°C/W	R_{th}	0.53		0.39	
Force constant ⁽⁶⁾ ⁽⁷⁾ ⁽⁸⁾	N/A_{pk} (lbf/ A_{pk})	K_f	35.0 (7.9)	105.0 (23.6)	35.0 (7.9)	70.0 (15.7)
Back EMF constant p-p ⁽⁶⁾ ⁽⁷⁾ ⁽⁸⁾	$V_p/m/s$ ($V_p/in/s$)	K_e	41.3 (1.1)	124.0 (3.2)	41.3 (1.1)	82.7 (2.1)
Current, peak ⁽⁵⁾ ⁽⁷⁾	A_{pk} (A_{rms})	I_p	27.2 (19.2)	9.1 (6.4)	36.3 (25.6)	18.1 (12.8)
Current, continuous ⁽¹⁾ ⁽²⁾ ⁽³⁾ ⁽⁴⁾	A_{pk} (A_{rms})	I_c	8.2 (5.8)	2.7 (1.9)	10.9 (7.7)	5.5 (3.9)
Resistance p-p @ 20 °C (68 °F) ⁽⁶⁾ ⁽⁸⁾	Ohms	R_{20}	2.37	21.33	1.78	7.11
Inductance p-p ⁽⁶⁾ ⁽⁸⁾	mH	L	3.69	33.25	2.77	11.08
Magnetic attraction	N (lbf)	F_a	0 (0)			

(1) Coils at maximum temperature, 130 °C (266 °F), mounted to an aluminum heat sink whose area is noted in table on [page 166](#), and at 40 °C (104 °F) ambient.

(2) Continuous force and current based on coil moving with all phases sharing the same load in sinusoidal commutation.

(3) For standstill conditions, multiply continuous force and continuous current by 0.9.

(4) Coil mountings on either of the two narrow sides reduces continuous force by 10%.

(5) Calculated at 11% duty cycle for 1.0 second, max. Some applications can produce significantly higher peak forces. Call Applications Engineering (631.344.6600) for details.

(6) Winding parameters listed are measured line-to-line (phase-to-phase).

(7) Currents and voltages listed are measured 0-peak of the sine wave unless noted as rms.

(8) Specifications are ±10%. Phase-to-phase inductance is ±30%.

Kinetix LDL Ironless Linear Motor (thick 50 mm frame size)

Attribute	Units	Symbol	LDL-T050120-DxTxx	LDL-T050240-DxTxx	LDL-T050240-ExTxx
Force, continuous ⁽¹⁾ ⁽²⁾ ⁽³⁾ ⁽⁴⁾	N (lbf)	F _c	110 (25)	220 (49)	
Force, peak ⁽⁵⁾	N (lbf)	F _p	364 (82)	728 (164)	
Thermal resistance	°C/W	R _{th}	1.19	0.60	
Force constant ⁽⁶⁾ ⁽⁷⁾ ⁽⁸⁾	N/A _{pk} (lbf/A _{pk})	K _f	40.2 (9.0)	40.2 (9.0)	80.4 (18.1)
Back EMF constant p-p ⁽⁶⁾ ⁽⁷⁾ ⁽⁸⁾	V _p /m/s (V _p /in/s)	K _e	47.4 (1.2)	47.4 (1.2)	94.9 (2.4)
Current, peak ⁽⁵⁾ ⁽⁷⁾	A _{pk} (A _{rms})	I _p	9.1 (6.4)	18.1 (12.8)	9.1 (6.4)
Current, continuous ⁽¹⁾ ⁽²⁾ ⁽³⁾ ⁽⁴⁾	A _{pk} (A _{rms})	I _c	2.7 (1.9)	5.5 (3.9)	2.7 (1.9)
Resistance p-p @ 20 °C (68 °F) ⁽⁶⁾ ⁽⁸⁾	Ohms	R ₂₀	9.42	4.71	18.83
Inductance p-p ⁽⁶⁾ ⁽⁸⁾	mH	L	18	9	35.31
Magnetic attraction	N (lbf)	F _a	0 (0)		

Attribute	Units	Symbol	LDL-T050360-DxTxx	LDL-T050360-ExTxx	LDL-T050480-DxTxx	LDL-T050480-ExTxx
Force, continuous ⁽¹⁾ ⁽²⁾ ⁽³⁾ ⁽⁴⁾	N (lbf)	F _c	329 (74)		439 (99)	
Force, peak ⁽⁵⁾	N (lbf)	F _p	1093 (246)		1457 (327)	
Thermal resistance	°C/W	R _{th}	0.40		0.30	
Force constant ⁽⁶⁾ ⁽⁷⁾ ⁽⁸⁾	N/A _{pk} (lbf/A _{pk})	K _f	40.2 (9.0)	120.5 (27.1)	40.2 (9.0)	80.4 (18.1)
Back EMF constant p-p ⁽⁶⁾ ⁽⁷⁾ ⁽⁸⁾	V _p /m/s (V _p /in/s)	K _e	47.4 (1.2)	142.3 (3.6)	47.4 (1.2)	94.9 (2.4)
Current, peak ⁽⁵⁾ ⁽⁷⁾	A _{pk} (A _{rms})	I _p	27.2 (19.2)	9.1 (6.4)	36.3 (25.6)	18.1 (12.8)
Current, continuous ⁽¹⁾ ⁽²⁾ ⁽³⁾ ⁽⁴⁾	A _{pk} (A _{rms})	I _c	8.2 (5.8)	2.7 (1.9)	10.9 (7.7)	5.5 (3.9)
Resistance p-p @ 20 °C (68 °F) ⁽⁶⁾ ⁽⁸⁾	Ohms	R ₂₀	3.14	28.25	2.35	9.42
Inductance p-p ⁽⁶⁾ ⁽⁸⁾	mH	L	5.88	52.96	4.41	17.65
Magnetic attraction	N (lbf)	F _a	0 (0)			

- (1) Coils at maximum temperature, 130 °C (266 °F), mounted to an aluminum heat sink whose area is noted in table on [page 166](#), and at 40 °C (104 °F) ambient.
- (2) Continuous force and current based on coil moving with all phases sharing the same load in sinusoidal commutation.
- (3) For standstill conditions, multiply continuous force and continuous current by 0.9.
- (4) Coil mountings on either of the two narrow sides reduces continuous force by 10%.
- (5) Calculated at 11% duty cycle for 1.0 second, max. Some applications can produce significantly higher peak forces. Call Applications Engineering (631.344.6600) for details.
- (6) Winding parameters listed are measured line-to-line (phase-to-phase).
- (7) Currents and voltages listed are measured 0-peak of the sine wave unless noted as rms.
- (8) Specifications are ±10%. Phase-to-phase inductance is ±30%.

Kinetix LDL Ironless Linear Motor (standard 75 mm frame size)

Attribute	Units	Symbol	LDL-N075480-DxTxx	LDL-N075480-ExTxx
Force, continuous ⁽¹⁾ (2) (3) (4)	N (lbf)	F_c	519 (117)	
Force, peak ⁽⁵⁾	N (lbf)	F_p	1723 (387)	
Thermal resistance	°C/W	R_{th}	0.37	
Force constant ⁽⁶⁾ (7) (8)	N/A_{pk} (lbf/A _{pk})	K_f	52.5 (11.8)	105.0 (23.6)
Back EMF constant p-p ⁽⁶⁾ (7) (8)	$V_p/m/s$ ($V_p/in/s$)	K_e	62.0 (1.6)	124.0 (3.2)
Current, peak ⁽⁵⁾ (7)	A_{pk} (A _{rms})	I_p	32.8 (23.2)	16.4 (11.6)
Current, continuous ⁽¹⁾ (2) (3) (4)	A_{pk} (A _{rms})	I_c	9.9 (7.0)	4.9 (3.5)
Resistance p-p @ 20 °C (68 °F) ⁽⁶⁾ (8)	Ohms	R_{20}	2.31	9.24
Inductance p-p ⁽⁶⁾ (8)	mH	L	3.60	14.40
Magnetic attraction	N (lbf)	F_a	0 (0)	

Kinetix LDL Ironless Linear Motor (thick 75 mm frame size)

Attribute	Units	Symbol	LDL-T075480-DxTxx	LDL-T075480-ExTxx
Force, continuous ⁽¹⁾ (2) (3) (4)	N (lbf)	F_c	596 (134)	
Force, peak ⁽⁵⁾	N (lbf)	F_p	1977 (444)	
Thermal resistance	°C/W	R_{th}	0.28	
Force constant ⁽⁶⁾ (7) (8)	N/A_{pk} (lbf/A _{pk})	K_f	60.3 (13.5)	120.5 (27.1)
Back EMF constant p-p ⁽⁶⁾ (7) (8)	$V_p/m/s$ ($V_p/in/s$)	K_e	71.2 (1.8)	142.3 (3.6)
Current, peak ⁽⁵⁾ (7)	A_{pk} (A _{rms})	I_p	32.8 (23.2)	16.4 (11.6)
Current, continuous ⁽¹⁾ (2) (3) (4)	A_{pk} (A _{rms})	I_c	9.9 (7.0)	4.9 (3.5)
Resistance p-p @ 20 °C (68 °F) ⁽⁶⁾ (8)	Ohms	R_{20}	3.06	12.25
Inductance p-p ⁽⁶⁾ (8)	mH	L	5.74	22.97
Magnetic attraction	N (lbf)	F_a	0 (0)	

(1) Coils at maximum temperature, 130 °C (266 °F), mounted to an aluminum heat sink whose area is noted in table on [page 166](#), and at 40 °C (104 °F) ambient.

(2) Continuous force and current based on coil moving with all phases sharing the same load in sinusoidal commutation.

(3) For standstill conditions, multiply continuous force and continuous current by 0.9.

(4) Coil mountings on either of the two narrow sides reduces continuous force by 10%.

(5) Calculated at 11% duty cycle for 1.0 second, max. Some applications can produce significantly higher peak forces. Call Applications Engineering (631.344.6600) for details.

(6) Winding parameters listed are measured line-to-line (phase-to-phase).

(7) Currents and voltages listed are measured 0-peak of the sine wave unless noted as rms.

(8) Specifications are ±10%. Phase-to-phase inductance is ±30%.

Weight Specifications

Motor Coil with Flying Leads

Cat. No.	Weight, approx kg (lb)
LDL-N030120-DHT20	0.63 (1.38)
LDL-T030120-DHT20	0.74 (1.64)
LDL-N030240-xHT20	1.14 (2.51)
LDL-T030240-xHT20	1.37 (3.02)
LDL-N050120-DHT20	0.75 (1.66)
LDL-T050120-DHT20	0.91 (2.01)
LDL-N050240-xHT20	1.39 (3.07)

Cat. No.	Weight, approx kg (lb)
LDL-T050240-xHT20	1.71 (3.77)
LDL-N050360-xHT20	2.03 (4.47)
LDL-T050360-xHT20	2.50 (5.52)
LDL-N050480-xHT20	2.67 (5.88)
LDL-T050480-xHT20	3.30 (7.28)
LDL-N075480-xHT20	3.32 (7.32)
LDL-T075480-xHT20	4.16 (9.18)

Motor Coil with Connectors

Cat. No.	Weight, approx kg (lb)
LDL-N030120-DHT11	0.83 (1.83)
LDL-T030120-DHT11	0.94 (2.07)
LDL-N030240-xHT11	1.34 (2.95)
LDL-T030240-xHT11	1.57 (3.46)
LDL-N050120-DHT11	0.95 (2.09)
LDL-T050120-DHT11	1.01 (2.22)
LDL-N050240-xHT11	1.41 (3.11)

Cat. No.	Weight, approx kg (lb)
LDL-T050240-xHT11	1.91 (4.21)
LDL-N050360-xHT11	2.23 (4.92)
LDL-T050360-xHT11	2.70 (5.95)
LDL-N050480-xHT11	3.50 (7.72)
LDL-T050480-xHT11	4.36 (9.61)
LDL-N075480-xHT11	3.52 (7.76)
LDL-T075480-xHT11	4.36 (9.61)

Motor Magnet Channel

Cat. No.	Weight, approx kg (lb)
LDL-NM030120	1.37 (3.02)
LDL-NM030480	5.51 (12.15)
LDL-TM030120	1.40 (3.08)
LDL-TM030480	5.60 (12.35)
LDL-NM050120	1.87 (4.12)
LDL-NM050480	7.48 (16.49)

Cat. No.	Weight, approx kg (lb)
LDL-TM050120	1.89 (4.17)
LDL-TM050480	7.57 (16.69)
LDL-NM075120	2.91 (6.42)
LDL-NM075480	11.64 (25.66)
LDL-TM075120	2.94 (6.48)
LDL-TM075480	11.76 (25.93)

Carriage Weight and Heat Sink Area Requirements

Cat. No.	Required Heat Sink Area cm ² (in. ²)	Required Carriage Plate Weight kg (lb)
LDL-x030120-DHTxx	774 (120)	1.4 (3)
LDL-x030240-xHTxx	1160 (180)	2.0 (4.5)
LDL-x050120-DHTxx	774 (120)	2.7 (6)
LDL-x050240-DHTxx	1160 (180)	4.0 (9)
LDL-x050360-DHTxx	1680 (260)	5.9 (13)
LDL-x050480-DHTxx	2060 (320)	7.3 (16)
LDL-x075480-xHTxx	2060 (320)	7.3 (16)

Dimensions - Kinetix LDL Ironless Linear Motor Components

Kinetix LDL ironless linear motor components are designed to metric dimensions. Inch dimensions are conversions from millimeters. Untoleranced dimensions are for reference.

LDL-xxxxxxx-xHT20 Motor Coil Dimensions (Flying Leads)

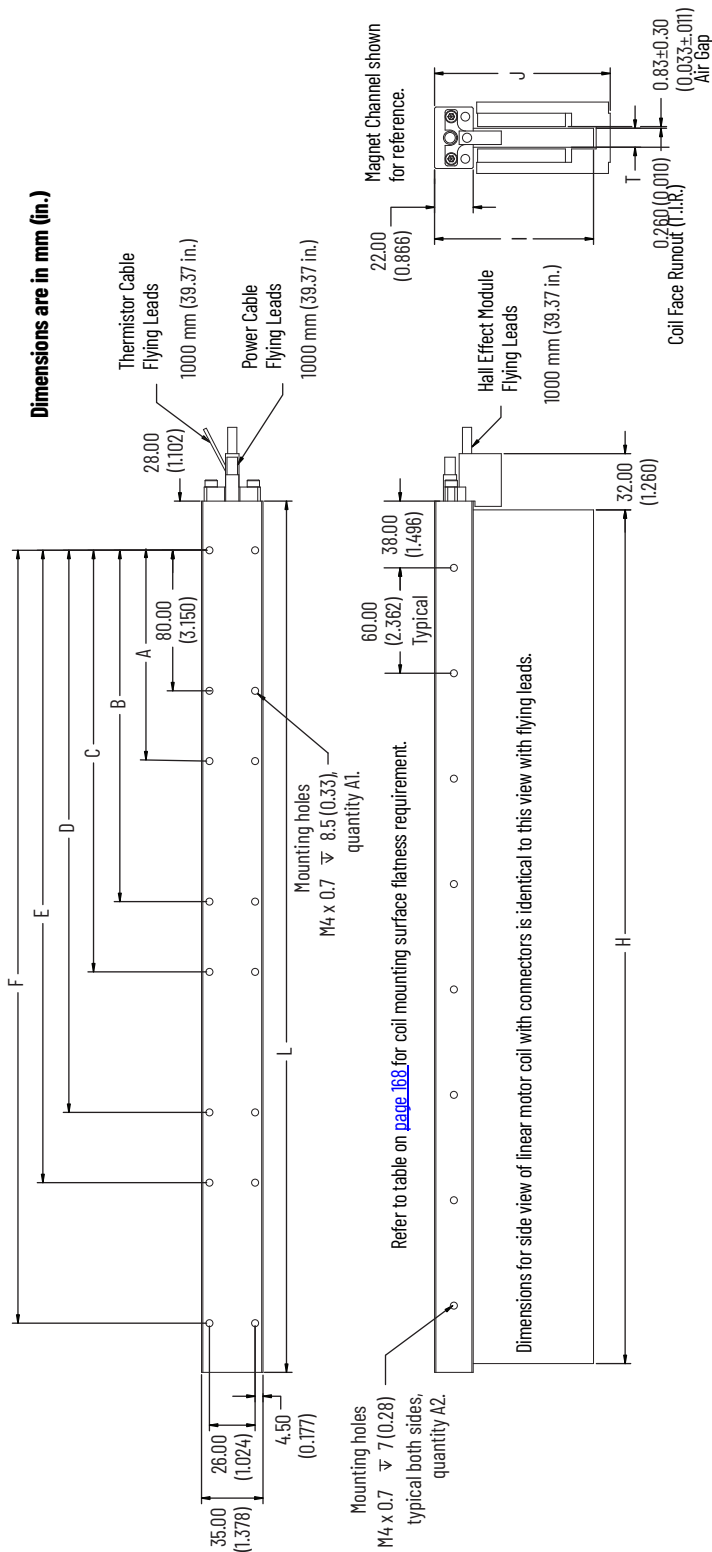

LDL-xxxxxxx-xHT11 Motor Coil Dimensions (connectors)

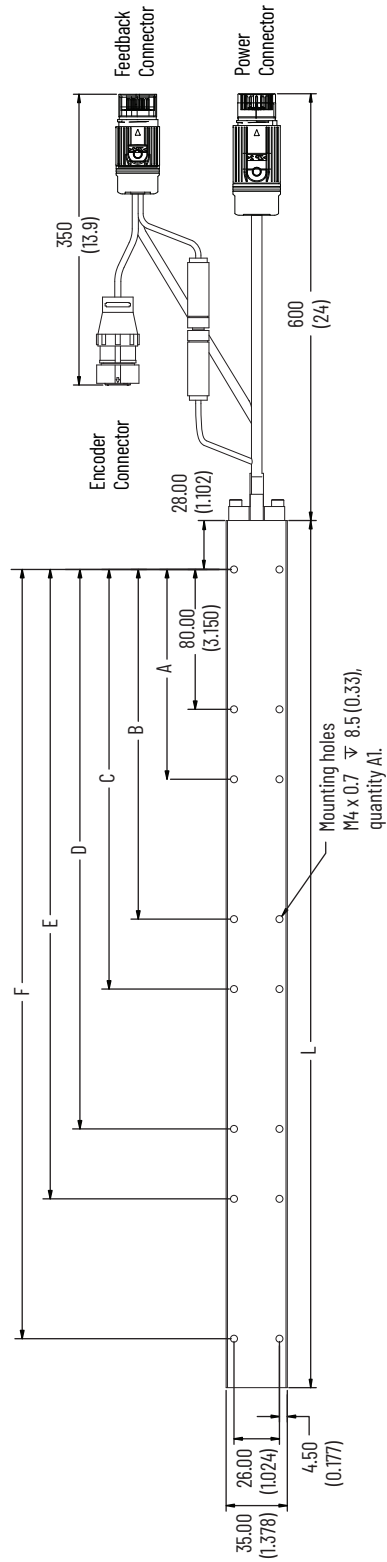

LDL-xxxx-xHTxx Motor Coil Dimensions

Cat. No.	L mm (in.)	A mm (in.)	B mm (in.)	C mm (in.)	D mm (in.)	E mm (in.)	F mm (in.)	G mm (in.)	H mm (in.)	I mm (in.)	J ⁽¹⁾ mm (in.)	T mm (in.)	A1 Qty	A2 Qty	Power Cable Gauge mm ² (AWG)	Flatness mm/300 x 300 (in./12 x 12)
LDL-N030120-DHTxx	136.0 (5.35)	-	-	-	-	-	-	60.00 (2.362)	126.00 (4.961)	70.50 (2.776)	80.00 (3.149)	8.30 (0.33) 10.80 (0.43)	4	2		
LDL-T030120-DHTxx																
LDL-N030240-xHTxx	256.0 (10.08)	120.00 (4.724)	200.00 (7.874)	-	-	-	-	180.00 (7.087)	246.00 (9.685)			8.30 (0.33) 10.80 (0.43)	8	4		0.25 (0.010)
LDL-T030240-xHTxx																
LDL-N050120-DHTxx	136.0 (5.35)	-	-	-	-	-	-	60.00 (2.362)	126.00 (4.961)			8.30 (0.33) 10.80 (0.43)	4	2	0.50 (20)	
LDL-T050120-DHTxx																
LDL-N050240-xHTxx	256.0 (10.08)	120.0 (4.724)	200 (7.874)	-	-	-	-	180.00 (7.087)	246.00 (9.685)			8.30 (0.33) 10.80 (0.43)	8	4		
LDL-T050240-xHTxx																
LDL-N050360-xHTxx	376.0 (14.80)	120.00 (4.724)	200 (7.874)	240.00 (9.449)	320.00 (12.598)	-	-	300.00 (11.811)	366.00 (14.409)	90.50 (3.563)	100.00 (3.937)	8.30 (0.33) 10.80 (0.43)	12	6		0.38 (0.015)
LDL-T050360-xHTxx																
LDL-N050480-DHTxx												8.30 (0.33)			0.75 (18)	
LDL-T050480-DHTxx															0.50 (20)	
LDL-N050480-EHTxx												10.80 (0.43)			0.50 (20)	
LDL-T050480-EHTxx															0.75 (18)	
LDL-N075480-DHTxx	496.0 (19.53)	120.00 (4.724)	200 (7.874)	240.00 (9.449)	320.00 (12.598)	360.00 (14.173)	440.00 (17.323)	420.00 (16.535)	486.00 (19.134)			8.30 (0.33)	16	8		0.64 (0.025)
LDL-T075480-DHTxx										115.50 (4.547)	130.00 (5.118)	10.80 (0.43)			0.50 (20)	
LDL-N075480-EHTxx															0.75 (18)	
LDL-T075480-EHTxx															0.50 (20)	

(1) Tolerance for J dimension is ±0.26 mm (0.010 in.).

Cable Specifications

Cable (1)	Conductors	Gauge mm ² (AWG)	Shield Type	Cable Dia. mm (in.)	Static Bend Radius mm (in.)
Power	4	0.82 (18)	Braid	7.0 (0.28)	18.0 (0.70)
Power	4	0.52 (20)	Braid	6.4 (0.25)	17.0 (0.67)
Thermistor	2	0.20 (26)	None	4.0 (0.16)	10.0 (0.40)
Hall Module	6	0.13 (24)	Foil	5.0 (0.20)	15.0 (0.59)

(1) All cables are non-flex.

Kinetix LDL Ironless Linear Motor Magnet Channel Dimensions

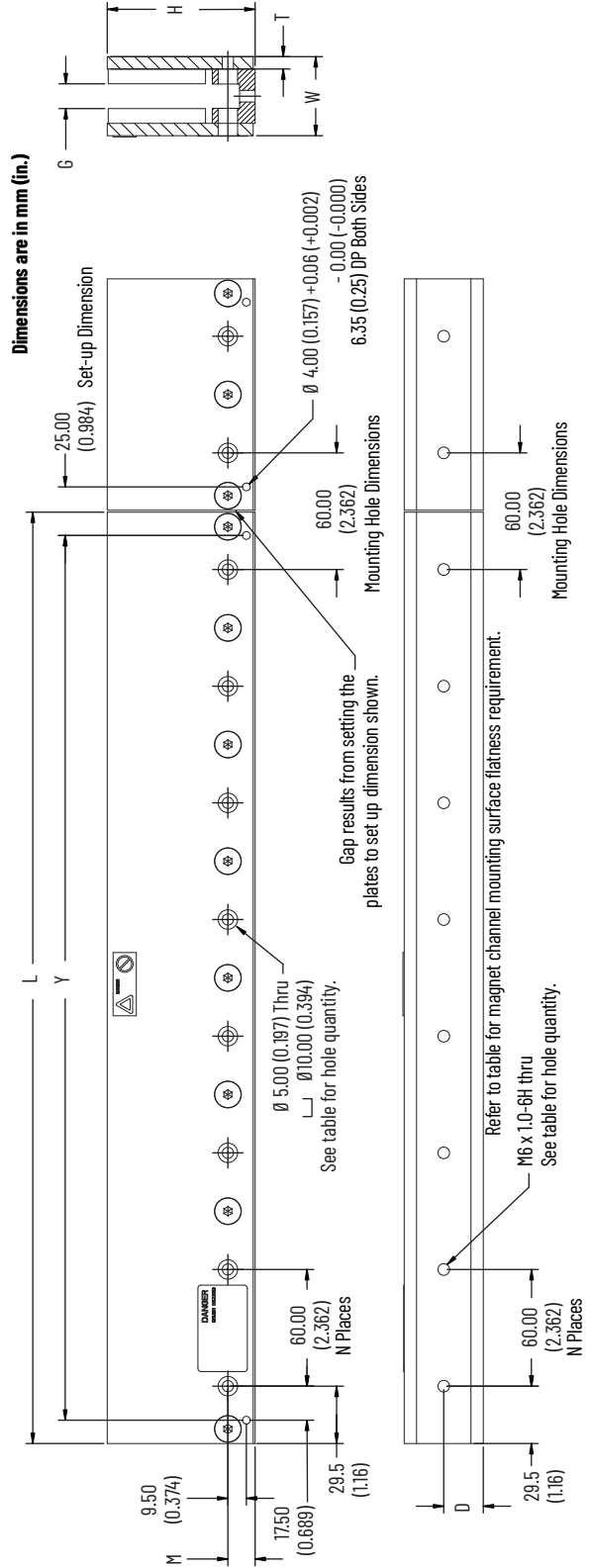

Cat. No.	W mm (in.)	H mm (in.)	T mm (in.)	G (1) mm (in.)	D mm (in.)	L (2) mm (in.)	M mm (in.)	N	Hole Qty	Y (3) mm (in.)	Flatness mm/300 x 300 (in./12 x 12)
LDL-NM030120	37.80 (1.488)	56.00 (2.205)	6.35 (0.250)	9.86 (0.388)	18.90 (0.744)	119.00 (4.685)	14.00 (0.551)	1	2	95.00 (3.740)	0.13 (0.005)
LDL-NM030480	40.65 (1.600)			12.57 (0.494)	20.33 (0.800)	479.00 (18.858)		7	8	455.00 (17.913)	0.26 (0.010)
LDL-TM030120	37.80 (1.488)	76.00 (2.992)	6.35 (0.250)	9.86 (0.388)	18.90 (0.744)	119.00 (4.685)	14.00 (0.551)	1	2	95.00 (3.740)	0.13 (0.005)
LDL-TM030480				12.57 (0.494)	20.33 (0.800)	479.00 (18.858)		7	8	455.00 (17.913)	0.26 (0.010)
LDL-NM050120	41.1 (1.62)	106.0 (4.173)	8.00 (0.315)	9.86 (0.388)	20.55 (0.809)	119.00 (4.685)	19.00 (0.748)	1	2	95.00 (3.740)	0.13 (0.005)
LDL-NM050480	40.65 (1.600)			12.57 (0.494)	20.33 (0.800)	479.00 (18.858)		7	8	455.00 (17.913)	0.26 (0.010)
LDL-TM050120	43.7 (1.72)	106.0 (4.173)	8.00 (0.315)	9.86 (0.388)	21.85 (0.860)	119.00 (4.685)	19.00 (0.748)	1	2	95.00 (3.740)	0.13 (0.005)
LDL-TM050480				12.57 (0.494)	21.85 (0.860)	479.00 (18.858)		7	8	455.00 (17.913)	0.26 (0.010)

(1) Tolerance for G dimension is +0.35 mm (+0.012 in.), -0.12 mm (-0.004 in.).

(2) Tolerance for L dimension is ±0.25 mm (±0.010 in.).

(3) Tolerance for Y dimension is ±0.05 mm (±0.002 in.).

Common Linear Motion Specifications

These specifications are common to all Kinetix Motion Control linear motor/actuator families.

Environmental Specifications - Kinetix Linear Motion

Attribute	Kinetix MP Integrated Linear Stages		Kinetix LDAT Integrated Linear Thrusters	Kinetix MP Electric Cylinders		Kinetix LDC and Kinetix LDL Linear Motors
	Kinetix MPAS	Kinetix MPMA		Kinetix MPAR	Kinetix MPAI	
Temperature, ambient	0...40 °C (32...104 °F)					
Temperature, storage	-30...70 °C (-22...158 °F)		-25...60 °C (-13...140 °F)		-30...70 °C (-22...158 °F)	
Relative humidity (noncondensing)	5...95%					
Shock	20 g peak, 6 ms duration					
Vibration	0.1 grms @ 30...2000 Hz		2.5 g peak @ 30...2000 Hz			

Environmental Ratings - Kinetix Linear Motion

IP Rating	Dust Protection ⁽¹⁾	Liquid Protection ⁽¹⁾	Linear Actuator/Motor	Description
IP30	Objects larger than 2.5 mm (0.098 in.)	No protection from liquids.	Kinetix LDAT	With strip cover option.
			Kinetix MPAS and MPMA	With unique, long life strip seal system.
IP40	Objects larger than 1.0 mm (0.039 in.)	No protection from liquids.	Kinetix MPAR	Applies to complete Kinetix MPAR or VPAR unit, including rod-end seal and breather port.
			Kinetix VPAR	
IP65		Protected against low-pressure jets of water from all directions.	Kinetix LDC	-
			Kinetix LDL	
IP66	Total protection from dust	Protected against strong jets of water.	Kinetix MPAR ⁽²⁾	Applies to electronic components and with the use of Rockwell Automation factory-delivered Kinetix 2090 cable connectors.
			Kinetix VPAR ⁽²⁾	Applies to electronic components and with the use of Rockwell Automation factory-delivered Kinetix 2090 single cable.
IP67		Protected against the effects of temporary liquid immersion.	Kinetix MPAI ⁽²⁾	With the use of Rockwell Automation factory-delivered Kinetix 2090 cable connectors.

(1) IP rating descriptions are for reference only. See the international standards for more complete rating descriptions.

(2) In static condition only. Maintain the front bearing and wiper seal at the prescribed interval. Wipe rods dry before motion occurs or liquid could be drawn inside the actuator.

Certifications - Kinetix Linear Motion

Linear Motor/Actuator Family	cULus ⁽¹⁾	CE ⁽²⁾
Kinetix MPAS and MPMA linear stages	X	X
Kinetix VPAR, MPAR, and MPAI electric cylinders	X	X
Kinetix LDAT linear thrusters	X	X
Kinetix LDC linear motors	X	X
Kinetix LDL linear motors	X	X

(1) UL recognized components to applicable UL and CSA standards.

(2) When product is marked, see the Product Certification link at rok.auto/certifications for Declarations of Conformity, certificates, and other certification details.

Motor Brake Application Guidelines

The brakes offered as options on the ballscrew driven linear stages and electric cylinders are holding brakes designed to hold the carriage/rod cylinder in position up to the rated brake holding torque. The brakes release when voltage is applied to the brake coil. Voltage and polarity supplied to the brake must be as specified to be sure of proper brake performance.

The brakes are not designed for stopping an actuator in motion. Use servo drive inputs to stop carriage/rod cylinder motion before the brake is activated. The recommended method of stopping motion is to command the servo drive to decelerate the carriage/rod cylinder to a complete stop and engage the brake only after the carriage/rod cylinder has stopped.

If system main power fails, the brakes can withstand use as stopping brakes. However, use of the brakes as stopping brakes can create mechanical backlash that is potentially damaging to the system, increases brake pad wear and reduces brake life. The brakes are not designed nor are they intended to be used as a safety device.

A separate power source is required to disengage the brake. This power source can be controlled by the linear stage controls, in addition to manual operator controls. Electrical arcing can occur at the relay contacts until the brake power dissipates. A customer supplied diode or metal oxide varistor (MOV) is recommended to prevent arcing. Use of an MOV can also reduce the time to mechanically engage the brake.

For more information on the use of holding brakes, see the Vertical Load and Holding Brake Management Application Technique, publication [MOTION-AT003](#).

Example Suppression Device for Brake Relay Contacts

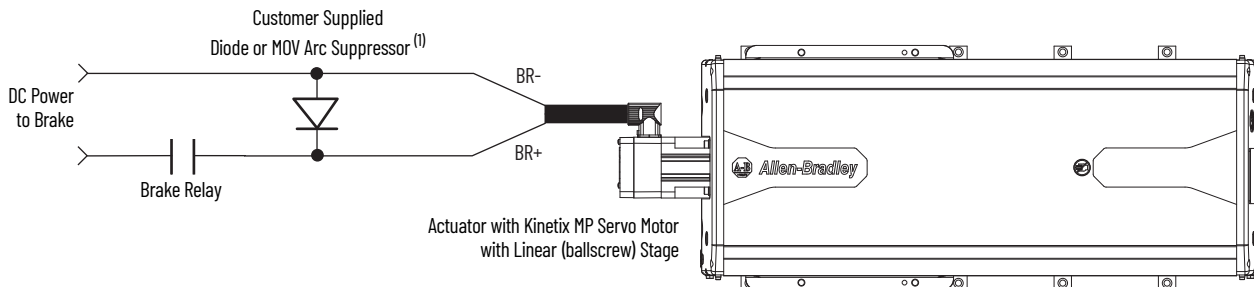

- (1) Kinetix 2000, Kinetix 5100, Kinetix 5300, Kinetix 5500, Kinetix 5700, Kinetix 6000, Kinetix 6200, Kinetix 6500, and Kinetix 7000 servo drives provide motor/actuator brake relay outputs and supply an MOV arc suppressor. A customer-supplied arc suppressor is not required unless the coil current of the brake is greater than the maximum brake current rating of the drive relay output.

Notes:

Additional Resources

These documents contain additional information concerning related products from Rockwell Automation.

Resource	Description
Kinetix Rotary Motion Specifications Technical Data, publication KNX-TD001	Product specifications for Kinetix VPL, VPC, VPF, VPH, and VPS; Kinetix MPL, MPM, MPF, and MPS; Kinetix TLY and TL; Kinetix HPK; and Kinetix MMA rotary motors.
Kinetix 5700, 5500, 5300, 5100 Servo Drives Specifications, publication KNX-TD003	Provides product specifications for Kinetix Integrated Motion over the EtherNet/IP network and EtherNet/IP networking servo drive families.
Kinetix Rotary and Linear Motion Cable Specifications Technical Data, publication KNX-TD004	Product specifications for Kinetix 2090 motor and interface cables.
Kinetix 3, 300, 350, 2000, 6000, 6200, 6500, 7000 Servo Drives Specifications, publication KNX-TD005	Provides product specifications for Kinetix Integrated Motion over the EtherNet/IP network (Kinetix 6500 and Kinetix 350), Integrated Motion over Sercos interface (Kinetix 6200, Kinetix 6000, Kinetix 2000, and Kinetix 7000), and component (Kinetix 3) servo drive families.
Kinetix 5500 Drive Systems Design Guide, publication KNX-RM009	Provides information to determine and select the required (drive specific) drive module, power accessory, connector kit, motor cable, and interface cable catalog numbers for your drive and motor/actuator motion control system. Includes system performance specifications and torque/speed curves (rotary motion) and force/velocity curves (linear motion) for your motion application.
Kinetix 5700 Drive Systems Design Guide, publication KNX-RM010	
Kinetix 5100 Drive Systems Design Guide, publication KNX-RM011	
Kinetix 5300 Drive Systems Design Guide, publication KNX-RM012	
Kinetix 6000 and Kinetix 6200/6500 Drive Systems Design Guide, publication KNX-RM003	
Kinetix 300/350 Drive Systems Design Guide, publication KNX-RM004	
Kinetix 3 Drive Systems Design Guide, publication KNX-RM005	
Kinetix 2000 Drive Systems Design Guide, publication KNX-RM006	
Kinetix 7000 Drive Systems Design Guide, publication GMC-RM007	
Kinetix MPAS Integrated Linear Stages User Manual, publication MP-UM001	
Kinetix MPMA Integrated Multi-axis Linear Stages User Manual, publication MPMA-UM001	
Kinetix VP Electric Cylinders Installation Instructions, publication VPAR-IN001	Provides information to install, configure, startup, and troubleshoot your Kinetix VPAR electric cylinders.
Kinetix MPAR Electric Cylinders (Series B and C) Installation Instructions, publication MPAR-IN001	Provides information to install, configure, startup, and troubleshoot your Kinetix MPAR electric cylinders. These are the Kinetix MPAR electric cylinders currently available.
Kinetix MPAR Electric Cylinders (Series A and B) Installation Instructions, publication MPAR-IN003	Provides information to install, configure, startup, and troubleshoot your Series A and B Kinetix MPAR electric cylinders. These are legacy Kinetix MPAR electric cylinders no longer available.
Kinetix MPAI Heavy Duty Electric Cylinders Installation Instructions, publication MPAI-IN001	Provides information to install, configure, startup, and troubleshoot your Kinetix MPAI heavy-duty electric cylinders.
Kinetix Motion Control Selection Guide, publication KNX-SG001	Provides an overview of Kinetix servo drives, motors, actuators, and motion accessories designed to help make initial decisions for the motion control products best suited for your system requirements.
System Design for Control of Electrical Noise Reference Manual, publication GMC-RM001	Provides information, examples, and techniques designed to minimize system failures caused by electrical noise.
Servo Drive Installation Best Practices Application Technique, publication MOTION-AT004	Best practice examples to help reduce the number of potential noise or electromagnetic interference (EMI) sources in your system and to make sure that the noise sensitive components are not affected by the remaining noise.
ControlLogix Selection Guide, publication 1756-SG001	Provides information to determine which ControlLogix® controller fits your application and the product specifications to help design a ControlLogix system and select the appropriate components.
CompactLogix Selection Guide, publication 1769-SG001	Provides information to determine which CompactLogix™ controller fits your application and the product specifications to help design a CompactLogix system and select the appropriate components.
Industrial Ethernet Media Brochure, publication 1585-BR001	Provides information to determine which Bulletin 1585 Ethernet cable fits your application and the product specifications to help select the appropriate components.
Motion Analyzer software, access online at https://motionanalyzer.rockwellautomation.com/	Comprehensive motion application used for sizing, analysis, optimization, selection, and validation of your Kinetix motion control system.
Rockwell Automation Product Selection website, rok.auto/systemtools	Provides online product selection and system configuration tools, including AutoCad (DXF) drawings.
Product Certifications website rok.auto/certifications	Provides declarations of conformity, certificates, and other certification details.

You can view or download publications at rok.auto/literature.

Rockwell Automation Support

Use these resources to access support information.

Technical Support Center	Find help with how-to videos, FAQs, chat, user forums, Knowledgebase, and product notification updates.	rok.auto/support
Local Technical Support Phone Numbers	Locate the telephone number for your country.	rok.auto/phonesupport
Technical Documentation Center	Quickly access and download technical specifications, installation instructions, and user manuals.	rok.auto/techdocs
Literature Library	Find installation instructions, manuals, brochures, and technical data publications.	rok.auto/literature
Product Compatibility and Download Center (PCDC)	Download firmware, associated files (such as AOP, EDS, and DTM), and access product release notes.	rok.auto/pcdc

Documentation Feedback

Your comments help us serve your documentation needs better. If you have any suggestions on how to improve our content, complete the form at rok.auto/docfeedback.





Allen-Bradley, ArmorKinetix, CompactLogix, ControlLogix, expanding human possibility, Integrated Architecture, Kinetix, Logix 5000, Rockwell Automation, Studio 5000 Logix Designer, and Ultra are trademarks of Rockwell Automation, Inc.

EtherNet/IP is a trademark of ODVA, Inc.

Trademarks not belonging to Rockwell Automation are property of their respective companies.

Rockwell Automation maintains current product environmental compliance information on its website at rok.auto/pec.

Rockwell Otomasyon Ticaret A.Ş. Kar Plaza İş Merkezi E Blok Kat:6 34752, İçerenköy, İstanbul, Tel: +90 (216) 5698400 EEE Yönetmeliğine Uygundur

Connect with us.    

rockwellautomation.com ————— expanding **human possibility**[®]

AMERICAS: Rockwell Automation, 1201 South Second Street, Milwaukee, WI 53204-2496 USA, Tel: (1) 414.382.2000, Fax: (1) 414.382.4444

EUROPE/MIDDLE EAST/AFRICA: Rockwell Automation NV, Pegasus Park, De Kleetlaan 12a, 1831 Diegem, Belgium, Tel: (32) 2 663 0600, Fax: (32) 2 663 0640

ASIA PACIFIC: Rockwell Automation, Level 14, Core F, Cyberport 3, 100 Cyberport Road, Hong Kong, Tel: (852) 2887 4788, Fax: (852) 2508 1846

UNITED KINGDOM: Rockwell Automation Ltd. Pitfield, Kiln Farm Milton Keynes, MK11 3DR, United Kingdom, Tel: (44)(1908) 838-800, Fax: (44)(1908) 261-917

Publication KNX-TD002G-EN-P - June 2023

Supersedes Publication KNX-TD002F-EN-P - October 2021

Copyright © 2023 Rockwell Automation, Inc. All rights reserved. Printed in the U.S.A.