

# SIEMENS

## RUGGEDCOM RX1510

### Installation Guide

#### Preface

---

#### Introduction

---

1

#### Installing the Device

---

2

#### Device Management

---

3

#### Modules

---

4

#### Technical Specifications

---

5

#### Certification

---

6

Copyright © 2018 Siemens Canada Ltd

All rights reserved. Dissemination or reproduction of this document, or evaluation and communication of its contents, is not authorized except where expressly permitted. Violations are liable for damages. All rights reserved, particularly for the purposes of patent application or trademark registration.

This document contains proprietary information, which is protected by copyright. All rights are reserved. No part of this document may be photocopied, reproduced or translated to another language without the prior written consent of Siemens Canada Ltd.

## » Disclaimer Of Liability

Siemens has verified the contents of this document against the hardware and/or software described. However, deviations between the product and the documentation may exist.

Siemens shall not be liable for any errors or omissions contained herein or for consequential damages in connection with the furnishing, performance, or use of this material.

The information given in this document is reviewed regularly and any necessary corrections will be included in subsequent editions. We appreciate any suggested improvements. We reserve the right to make technical improvements without notice.

## » Registered Trademarks

RUGGEDCOM™ and ROS™ are trademarks of Siemens Canada Ltd.

Linux® is the registered trademark of Linus Torvalds in the United States and other countries.

The registered trademark Linux® is used pursuant to a sublicense from LMI, the exclusive licensee of Linus Torvalds, owner of the mark on a world-wide basis.

Other designations in this manual might be trademarks whose use by third parties for their own purposes would infringe the rights of the owner.

## » Security Information

Siemens provides products and solutions with industrial security functions that support the secure operation of plants, machines, equipment and/or networks. They are important components in a holistic industrial security concept. With this in mind, Siemens' products and solutions undergo continuous development. Siemens recommends strongly that you regularly check for product updates.

For the secure operation of Siemens products and solutions, it is necessary to take suitable preventive action (e.g. cell protection concept) and integrate each component into a holistic, state-of-the-art industrial security concept. Third-party products that may be in use should also be considered. For more information about industrial security, visit <https://www.siemens.com/industrialsecurity>.

To stay informed about product updates as they occur, sign up for a product-specific newsletter. For more information, visit <https://support.automation.siemens.com>.

## » Warranty

Siemens warrants this product for a period of five (5) years from the date of purchase, conditional upon the return to factory for maintenance during the warranty term. This product contains no user-serviceable parts. Attempted service by unauthorized personnel shall render all warranties null and void. The warranties set forth in this article are exclusive and are in lieu of all other warranties, performance guarantees and conditions whether written or oral, statutory, express or implied (including all warranties and conditions of merchantability and fitness for a particular purpose, and all warranties and conditions arising from course of dealing or usage or trade). Correction of nonconformities in the manner and for the period of time provided above shall constitute the Seller's sole liability and the Customer's exclusive remedy for defective or nonconforming goods or services whether claims of the Customer are based in contract (including fundamental breach), in tort (including negligence and strict liability) or otherwise.

For warranty details, visit <https://www.siemens.com/ruggedcom> or contact a Siemens customer service representative.

## » Contacting Siemens

**Address**  
Siemens Canada Ltd

**Telephone**  
Toll-free: 1 888 264 0006

**E-mail**  
[ruggedcom.info.i-ia@siemens.com](mailto:ruggedcom.info.i-ia@siemens.com)

Industry Sector  
300 Applewood Crescent  
Concord, Ontario  
Canada, L4K 5C7

Tel: +1 905 856 5288  
Fax: +1 905 856 1995

**Web**  
<https://www.siemens.com/ruggedcom>



# Table of Contents

Preface .....	vii
Alerts .....	vii
Related Documents .....	viii
Accessing Documentation .....	viii
Training .....	viii
Customer Support .....	viii
Chapter 1	
Introduction .....	1
1.1 Feature Highlights .....	1
1.2 Description .....	2
1.3 Required Tools and Materials .....	3
1.4 Decommissioning and Disposal .....	3
1.5 Cabling Recommendations .....	4
1.5.1 Protection On Twisted-Pair Data Ports .....	4
1.5.2 Gigabit Ethernet 1000Base-TX Cabling Recommendations .....	4
Chapter 2	
Installing the Device .....	5
2.1 General Procedure .....	6
2.2 Unpacking the Device .....	6
2.3 Mounting the Device .....	6
2.3.1 Mounting the Device on a DIN Rail .....	7
2.3.2 Mounting the Device to a Panel .....	7
2.4 Connecting the Failsafe Alarm Relay .....	8
2.5 Connecting Power .....	9
2.5.1 Connecting High AC/DC Power .....	10
2.5.2 Connecting Low DC Power .....	11
Chapter 3	
Device Management .....	13
3.1 Connecting to the Device .....	13
3.2 Configuring the Device .....	15
3.3 Accessing the CompactFlash Card .....	15

## Chapter 4

<b>Modules</b> .....	19
4.1 Available Modules .....	20
4.2 Installing/Removing Line Modules .....	28
4.3 Installing/Removing Power Modules .....	30

## Chapter 5

<b>Technical Specifications</b> .....	33
5.1 Power Supply Specifications .....	33
5.2 Failsafe Relay Specifications .....	34
5.3 Operating Environment .....	34
5.4 Mechanical Specifications .....	34
5.5 Dimension Drawings .....	34

## Chapter 6

<b>Certification</b> .....	39
6.1 Approvals .....	39
6.1.1 TÜV SÜD .....	39
6.1.2 European Union (EU) .....	40
6.1.3 FCC .....	41
6.1.4 FDA/CDRH .....	41
6.1.5 ISED .....	41
6.1.6 RoHS .....	41
6.1.7 Other Approvals .....	42
6.2 EMC and Environmental Type Tests .....	42

# Preface

This guide describes the RUGGEDCOM RUGGEDCOM RX1510. It describes the major features of the device, installation, commissioning and important technical specifications.

It is intended for use by network technical support personnel who are responsible for the installation, commissioning and maintenance of the device. It is also recommended for use by network and system planners, system programmers, and line technicians.

## CONTENTS

- [“Alerts”](#)
- [“Related Documents”](#)
- [“Accessing Documentation”](#)
- [“Training”](#)
- [“Customer Support”](#)

## Alerts

The following types of alerts are used when necessary to highlight important information.



### **DANGER!**

*DANGER alerts describe imminently hazardous situations that, if not avoided, will result in death or serious injury.*



### **WARNING!**

*WARNING alerts describe hazardous situations that, if not avoided, may result in serious injury and/or equipment damage.*



### **CAUTION!**

*CAUTION alerts describe hazardous situations that, if not avoided, may result in equipment damage.*



### **IMPORTANT!**

*IMPORTANT alerts provide important information that should be known before performing a procedure or step, or using a feature.*



### **NOTE**

*NOTE alerts provide additional information, such as facts, tips and details.*

## Related Documents

Other documents that may be of interest include:

- [RUGGEDCOM ROX II CLI User Guide](https://support.industry.siemens.com/cs/ww/en/view/109481699) [https://support.industry.siemens.com/cs/ww/en/view/109481699]
- [RUGGEDCOM ROX II Web Interface User Guide](https://support.industry.siemens.com/cs/ww/en/view/109481700) [https://support.industry.siemens.com/cs/ww/en/view/109481700]
- [RUGGEDCOM ROX II Modules Catalog](https://support.industry.siemens.com/cs/ww/en/view/109747072) [https://support.industry.siemens.com/cs/ww/en/view/109747072]

## Accessing Documentation

The latest user documentation for RUGGEDCOM RX1510 is available online at <https://www.siemens.com/ruggedcom>. To request or inquire about a user document, contact Siemens Customer Support.

## Training

Siemens offers a wide range of educational services ranging from in-house training of standard courses on networking, Ethernet switches and routers, to on-site customized courses tailored to the customer's needs, experience and application.

Siemens' Educational Services team thrives on providing our customers with the essential practical skills to make sure users have the right knowledge and expertise to understand the various technologies associated with critical communications network infrastructure technologies.

Siemens' unique mix of IT/Telecommunications expertise combined with domain knowledge in the utility, transportation and industrial markets, allows Siemens to provide training specific to the customer's application.

For more information about training services and course availability, visit <https://www.siemens.com/ruggedcom> or contact a Siemens Sales representative.

## Customer Support

Customer support is available 24 hours, 7 days a week for all Siemens customers. For technical support or general information, contact Siemens Customer Support through any of the following methods:



### Online

Visit <http://www.siemens.com/automation/support-request> to submit a Support Request (SR) or check on the status of an existing SR.

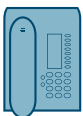

### Telephone

Call a local hotline center to submit a Support Request (SR). To locate a local hotline center, visit <http://www.automation.siemens.com/mcms/aspa-db/en/automation-technology/Pages/default.aspx>.



### **Mobile App**

Install the Industry Online Support app by Siemens AG on any Android, Apple iOS or Windows mobile device and be able to:

- Access Siemens' extensive library of support documentation, including FAQs and manuals
- Submit SRs or check on the status of an existing SR
- Contact a local Siemens representative from Sales, Technical Support, Training, etc.
- Ask questions or share knowledge with fellow Siemens customers and the support community



# 1 Introduction

The RUGGEDCOM RUGGEDCOM RX1510 is a cost-efficient, rugged Layer 3 switch and router. The RUGGEDCOM RX1510's modular and field replaceable platform can be equipped with WAN, serial, and Ethernet options, making it ideally suited for electric power utilities, the industrial plant floor, and traffic control systems. The appliance's compact form factor makes it ideal for pole mount applications or installation in restricted spaces.

The RUGGEDCOM RX1510 is designed to provide a high level of immunity to electromagnetic interference (EMI) and heavy electrical surges typical of the harsh environments found in many industrial applications. An operating temperature range of -40 to 85 °C (-40 to 185 °F) allows the RUGGEDCOM RX1510 to be placed in almost any location.

## CONTENTS

- [Section 1.1, "Feature Highlights"](#)
- [Section 1.2, "Description"](#)
- [Section 1.3, "Required Tools and Materials"](#)
- [Section 1.4, "Decommissioning and Disposal"](#)
- [Section 1.5, "Cabling Recommendations"](#)

## Section 1.1

# Feature Highlights

### Reliability in Harsh Environments

- Immunity to EMI and high voltage electrical transients
- -40 to 85 °C (-40 to 185 °F) operating temperature (no fans)
- Failsafe output relay for critical failure or error alarming

### Universal Power Supply Options

- Dual redundant, modular, hot-swappable power supplies
- Fully integrated power supplies (no external adapters)
- Input voltage ranges: 13-36 VDC and 37-72 VDC or 85-264 VAC and 88-300 VDC for worldwide operability
- CSA/UL 60950-1 safety approved to 85 °C (185 °F)

### Physical Ports

- Field replaceable line modules
- Up to 24 100Base-FX ports
- Up to 24 10/100Base-TX ports
- Up to 12 10Base-FL/100Base-SX ports
- Up to 8 Gigabit Ethernet ports
- Up to 24 serial ports
- Up to 4 T1/E1 RJ48C ports or 2 E1 BNC ports
- Up to 2 DDS (Digital Data Services) ports
- Up to 8 active cellular data interfaces

Section 1.2

# Description

The RUGGEDCOM RX1510 features various ports, controls and indicator LEDs on the front panel for connecting, configuring and troubleshooting the device.

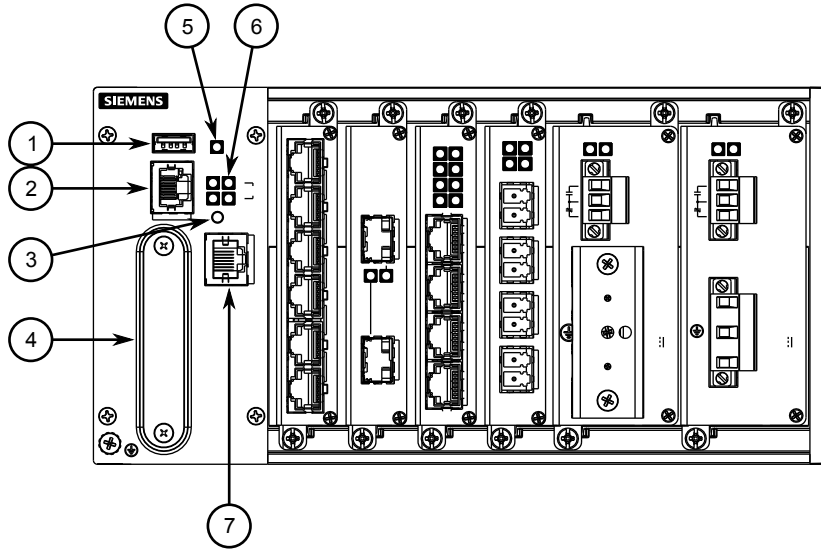

**Figure 1: RUGGEDCOM RX1510**

1. Utility USB Port 2. RS232 Serial Console Port (RJ45) 3. Lamp Test/Alarm Cut-Off (LT/ACO) Button 4. Compact Flash Card Port  
5. Alarm Indicator LED 6. Port Status LEDs 7. Management Port

<b>Management Port</b>	This 10/100Base-T Ethernet port is used for system management that is out-of-band from the switch fabric.
<b>RS-232 Serial Console Port</b>	The serial console port is for interfacing directly with the device and accessing initial management functions. For information about connecting to the device via the serial console port, refer to <a href="#">Section 3.1, "Connecting to the Device"</a> .
<b>Utility USB Port</b>	Use the USB port to upgrade the ROX II software or install files, such as configuration files and feature key files. For more information, refer to the <i>RUGGEDCOM ROX II User Guide</i> for the RUGGEDCOM RX1510.
<b>Lamp Test/Alarm Cut-Off (LT/ACO) Button</b>	This button performs two functions: <ul style="list-style-type: none"> <li>• Press and hold this button to test all indicator LEDs</li> <li>• Press and release this button to acknowledge an active alarm</li> </ul>
<b>Power Status LEDs</b>	Indicates the status of the power modules. <ul style="list-style-type: none"> <li>• Green = Power is on</li> <li>• Off = Power is off</li> </ul>
<b>Port Status LEDs</b>	Indicates when ports are active. <ul style="list-style-type: none"> <li>• Green = OK</li> <li>• Orange = Warning alert</li> <li>• Red = Configuration error</li> </ul>
<b>Alarm Indicator LED</b>	Indicates when an alarm condition exists. <ul style="list-style-type: none"> <li>• Green = Alarms cleared/acknowledged</li> </ul>

- Red = Alarm

**Compact Flash Card Port**

Houses the CompactFlash (CF) card that contains active and backup installations of RUGGEDCOM ROX II, along with the configuration database and other system data. For more information, refer to [Section 3.3, "Accessing the CompactFlash Card"](#).

## Section 1.3

## Required Tools and Materials

The following tools and materials are required to install the RUGGEDCOM RX1510:

Tools/Materials	Purpose
AC/DC power cord (16 AWG)	For connecting power to the device.
Lightning protector	For protecting the device from harmful electrical strikes.
Shielded coaxial cables	For connecting the device to antennas and an Ethernet network.
SIM Card(s) provided by the network carrier	For accessing a network carrier's cellular network. Required only if a cellular modem module is equipped.
Flathead screwdriver	For mounting the device to a DIN rail.
Phillips screwdriver	For mounting the device to a panel.
4 x #6-32 screws	For mounting the device to a panel.
Braided or equivalent ground wire	For grounding the device to safety Earth.

## Section 1.4

## Decommissioning and Disposal

Proper decommissioning and disposal of this device is important to prevent malicious users from obtaining proprietary information and to protect the environment.

### » Decommissioning

This device may include sensitive, proprietary data. Before taking the device out of service, either permanently or for maintenance by a third-party, make sure it has been fully decommissioned.

For more information, refer to the associated *User Guide*.

### » Recycling and Disposal

For environmentally friendly recycling and disposal of this device and related accessories, contact a facility certified to dispose of waste electrical and electronic equipment. Recycling and disposal must be done in accordance with local regulations.

## Section 1.5

# Cabling Recommendations

Siemens recommends using SIMATIC NET industrial Ethernet shielded cables for all Ethernet ports.

**CONTENTS**

- [Section 1.5.1, "Protection On Twisted-Pair Data Ports"](#)
- [Section 1.5.2, "Gigabit Ethernet 1000Base-TX Cabling Recommendations"](#)

## Section 1.5.1

## Protection On Twisted-Pair Data Ports

All copper Ethernet ports on RUGGEDCOM products include transient suppression circuitry to protect against damage from electrical transients and conform with IEC 61850-3 and IEEE 1613 Class 1 standards. This means that during a transient electrical event, communications errors or interruptions may occur, but recovery is automatic.

Siemens also does not recommend using copper Ethernet ports to interface with devices in the field across distances that could produce high levels of ground potential rise (i.e. greater than 2500 V), during line-to-ground fault conditions.

## Section 1.5.2

## Gigabit Ethernet 1000Base-TX Cabling Recommendations

The IEEE 802.3ab Gigabit Ethernet standard defines 1000 Mbit/s Ethernet communications over distances of up to 100 m (328 ft) using all 4 pairs in category 5 (or higher) balanced, unshielded twisted-pair cabling. For wiring guidelines, system designers and integrators should refer to the Telecommunications Industry Association (TIA) TIA/EIA-568-A wiring standard that characterizes minimum cabling performance specifications required for proper Gigabit Ethernet operation. For reliable, error-free data communication, new and pre-existing communication paths should be verified for TIA/EIA-568-A compliance.

The following table summarizes the relevant cabling standards:

Cabling Category	1000Base-TX Compliant	Required Action
< 5	No	New wiring infrastructure required.
5	Yes	Verify TIA/EIA-568-A compliance.
5e	Yes	No action required. New installations should be designed with Category 5e or higher.
6	Yes	No action required.
> 6	Yes	Connector and wiring standards to be determined.

Follow these recommendations for copper data cabling in high electrical noise environments:

- Data cable lengths should be as short as possible, preferably 3 m (10 ft) in length. Copper data cables should not be used for inter-building communications.
- Power and data cables should not be run in parallel for long distances, and should be installed in separate conduits. Power and data cables should intersect at 90° angles when necessary to reduce inductive coupling.

# 2 Installing the Device

This chapter describes how to install the device, including mounting the device, connecting power, and connecting the device to the network.



## DANGER!

*Electrocution hazard – risk of serious personal injury and/or damage to equipment. Before performing any maintenance tasks, make sure all power to the device has been disconnected and wait approximately two minutes for any remaining energy to dissipate.*



## WARNING!

*Radiation hazard – risk of serious personal injury. This product contains a laser system and is classified as a **CLASS 1 LASER PRODUCT**. Use of controls or adjustments or performance of procedures other than those specified herein may result in hazardous radiation exposure.*



## WARNING!

*Radiation hazard – risk of Radio Frequency (RF) exposure. This device is compliant with the requirements set forth in FCC 47 CFR, section 1.1307, addressing Radio Frequency (RF) exposure from radio frequency base stations, as defined in FCC OET Bulletin 65 [[http://transition.fcc.gov/Bureaus/Engineering\\_Technology/Documents/bulletins/oet65/oet65.pdf](http://transition.fcc.gov/Bureaus/Engineering_Technology/Documents/bulletins/oet65/oet65.pdf)]. The emitted radiation should be as little as possible. To achieve minimum RF exposure, install the device when it is configured not to transmit and set it to operational mode remotely, rather than having a technician enable transmission on-site. For maintenance of the base station, or other operations which require RF exposure, the exposure should be minimized in time and according to the regulations set forth by the country of installation or the Federal Communications Commission (FCC).*



## IMPORTANT!

*This product contains no user-serviceable parts. Attempted service by unauthorized personnel shall render all warranties null and void.*

*Changes or modifications not expressly approved by Siemens Canada Ltd could invalidate specifications, test results, and agency approvals, and void the user's authority to operate the equipment.*



## IMPORTANT!

*This product should be installed in a **restricted access location** where access can only be gained by authorized personnel who have been informed of the restrictions and any precautions that must be taken. Access must only be possible through the use of a tool, lock and key, or other means of security, and controlled by the authority responsible for the location.*

## CONTENTS

- [Section 2.1, "General Procedure"](#)
- [Section 2.2, "Unpacking the Device"](#)
- [Section 2.3, "Mounting the Device"](#)

- [Section 2.4, "Connecting the Failsafe Alarm Relay"](#)
- [Section 2.5, "Connecting Power"](#)

## Section 2.1

# General Procedure

The general procedure for installing the device is as follows:

1. Review the relevant certification information for any regulatory requirements. For more information, refer to [Section 6.1, "Approvals"](#).
2. Review the *RUGGEDCOM RX1500 Series Modules Catalog* for special installation or regulatory requirements related to the modules installed in the device. In the case of cellular modem line modules, this includes antenna installation and regulatory requirements.
3. Mount the device.
4. Connect the failsafe alarm relay.
5. Connect power to the device and ground the device to safety Earth.
6. Connect the device to the network.
7. Configure the device.

## Section 2.2

# Unpacking the Device

When unpacking the device, do the following:

1. Inspect the package for damage before opening it.
2. Visually inspect each item in the package for any physical damage.
3. Verify all items are included.



### IMPORTANT!

*If any item is missing or damaged, contact Siemens for assistance.*

## Section 2.3

# Mounting the Device

The RUGGEDCOM RX1510 is designed for maximum mounting and display flexibility. It can be equipped with connectors that allow it to be installed in a 35 mm (1.4 in) DIN rail, or directly on a panel.



### IMPORTANT!

*Heat generated by the device is channeled outwards from the enclosure. As such, it is recommended that 2.5 cm (1 in) of space be maintained on all open sides of the device to allow for some convective airflow.*

Forced airflow is not required. However, any increase in airflow will result in a reduction of ambient temperature and improve the long-term reliability of all equipment mounted in the rack space.

**NOTE**  
For detailed dimensions of the device with either DIN rail or panel hardware installed, refer to [Section 5.5, "Dimension Drawings"](#).

- CONTENTS**
- [Section 2.3.1, "Mounting the Device on a DIN Rail"](#)
  - [Section 2.3.2, "Mounting the Device to a Panel"](#)

Section 2.3.1

## Mounting the Device on a DIN Rail

For DIN rail installations, the RUGGEDCOM RX1510 can be equipped with panel/DIN rail adapters pre-installed on each side of the chassis. The adapters allow the device to be slid onto a standard 35 mm (1.4 in) DIN rail.

To mount the device to a DIN rail, do the following:

1. Align the adapters with the DIN rails and slide the device into place.

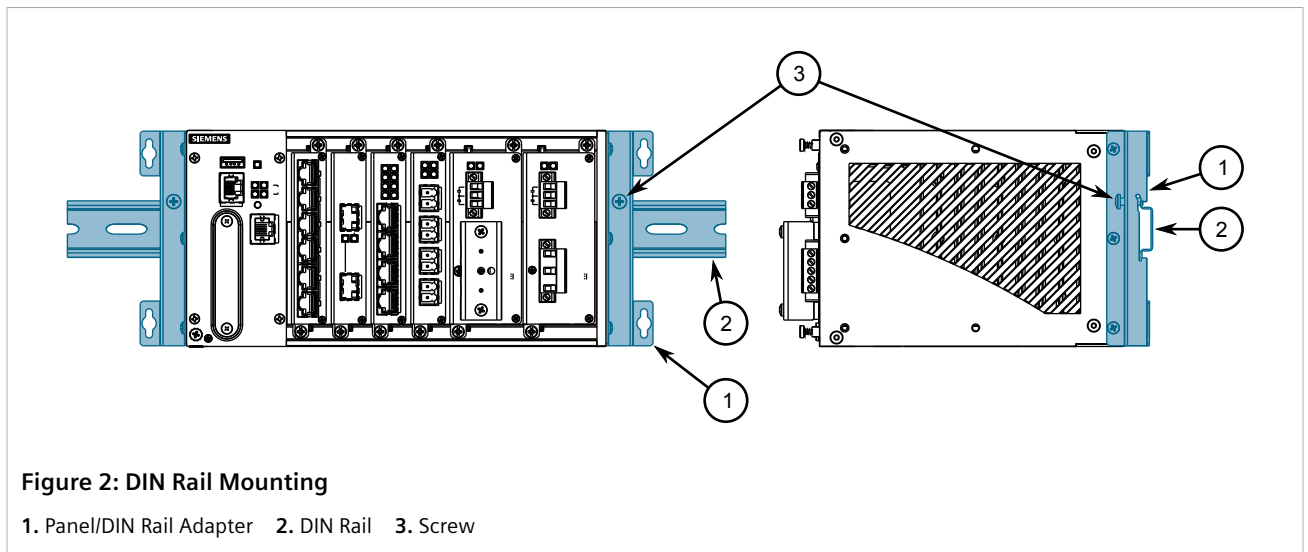

2. Install one of the supplied screws on either side of the device to secure the adapters to the DIN rails.

Section 2.3.2

## Mounting the Device to a Panel

For panel installations, the RUGGEDCOM RX1510 can be equipped with panel/DIN rail adapters pre-installed on each side of the chassis. The adapters allow the device to be attached to a panel using screws.

To mount the device to a panel, do the following:

1. Place the device against the panel and mark the mounting holes on the panel.

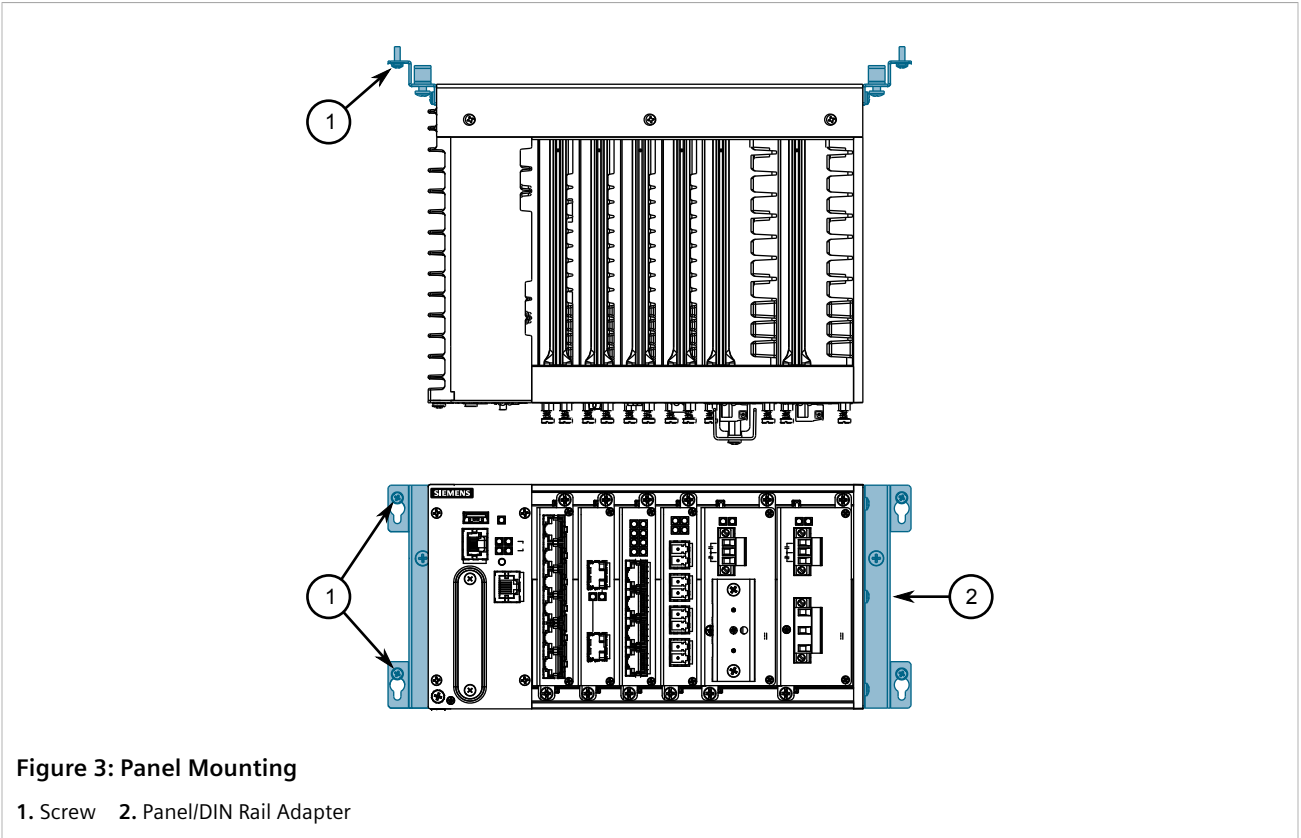

2. Prepare the mounting holes
3. Align the device with the mounting holes and secure it to the panel.

#### Section 2.4

## Connecting the Failsafe Alarm Relay

The failsafe relay can be configured to latch based on alarm conditions. The NO (Normally Open) contact is closed when the unit is powered and there are no active alarms. If the device is not powered or if an active alarm is configured, the relay opens the NO contact and closes the NC (Normally Closed) contact.



#### NOTE

*Control of the failsafe relay output is configurable through ROX II. One common application for this relay is to signal an alarm if a power failure occurs. For more information, refer to the ROX II User Guide for the RUGGEDCOM RX1510.*

The following shows the proper relay connections.

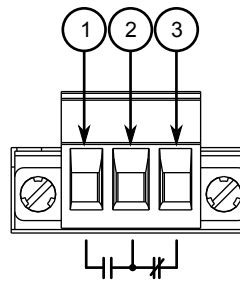

**Figure 4: Failsafe Alarm Relay Wiring**

1. Normally Open 2. Common 3. Normally Closed

## Section 2.5

# Connecting Power

The RUGGEDCOM RX1510 supports dual redundant high AC, high DC and/or low DC power modules that can be installed in any combination. The use of two power modules is recommended to provide redundancy and load balancing.

Power modules are equipped with a pluggable terminal block. Use #6 size ring lugs for secure, reliable connections under severe shock or vibration.

For information about installing or removing a power module, refer to [Section 4.3, "Installing/Removing Power Modules"](#).



### DANGER!

*Electrocution hazard – risk of serious personal injury or death. The device may have two power modules equipped, which may be connected to separate power sources. Make sure all power sources are off before servicing the power module terminals.*



### IMPORTANT!

- *In a high AC/DC and low DC (24/48 V) power module arrangement, the placement of the AC and DC power supplies is not slot-dependent. Either power module slot can be used for AC or DC power.*
- *For maximum redundancy in a dual power module configuration, use two independent power sources.*
- *Use minimum #16 gage copper wiring when connecting terminal blocks.*
- *The maximum wire length between the terminal block and power source must not exceed 6 m (20 ft) for 24 V power supplies or 18 m (60 ft) for 48 V power supplies.*
- *For 125/230 VAC rated equipment, an appropriately rated AC circuit breaker must be installed.*
- *For 125/250 VDC rated equipment, an appropriately rated DC circuit breaker must be installed.*
- *It is recommended to provide a 20 A circuit breaker for the power module.*
- *Equipment must be installed according to applicable local wiring codes and standards.*

### CONTENTS

- [Section 2.5.1, "Connecting High AC/DC Power"](#)

- Section 2.5.2, "Connecting Low DC Power"

Section 2.5.1

## Connecting High AC/DC Power

To connect a high AC/DC power supply to the device, do the following:



**CAUTION!**

*Electrical hazard – risk of damage to equipment. Do not connect AC power cables to a 12, 24 or 48 VDC power supply terminal block. Damage to the power supply may occur.*

1. Connect the power supply terminal block to the device.

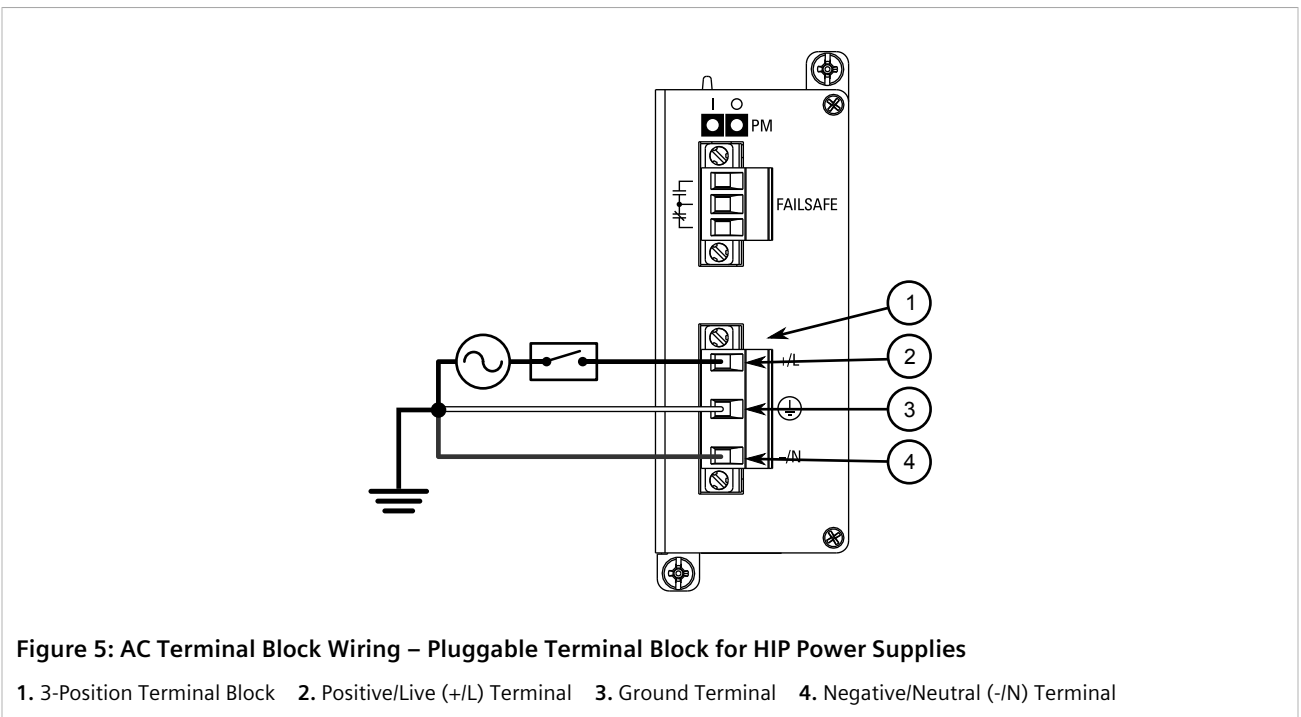

**Figure 5: AC Terminal Block Wiring – Pluggable Terminal Block for HIP Power Supplies**

1. 3-Position Terminal Block 2. Positive/Live (+/L) Terminal 3. Ground Terminal 4. Negative/Neutral (-/N) Terminal

2. Connect the positive wire from the power source to the positive/live (+/L) terminal on the terminal block.
3. Connect the negative wire from the power source to the neutral/negative (-/N) terminal on the terminal block.
4. Using a braided wire or other appropriate grounding wire, connect the ground terminal to the chassis ground connection. The ground terminal is used as the ground conductor for surge and transient suppression circuitry internal to the unit.
5. Using a #10 ring lug and #10-32 screw, secure the ground terminal on the power source to the chassis ground terminal on the device. Make sure the lug is tightened to 3.4 N·m (30 lbf·in).

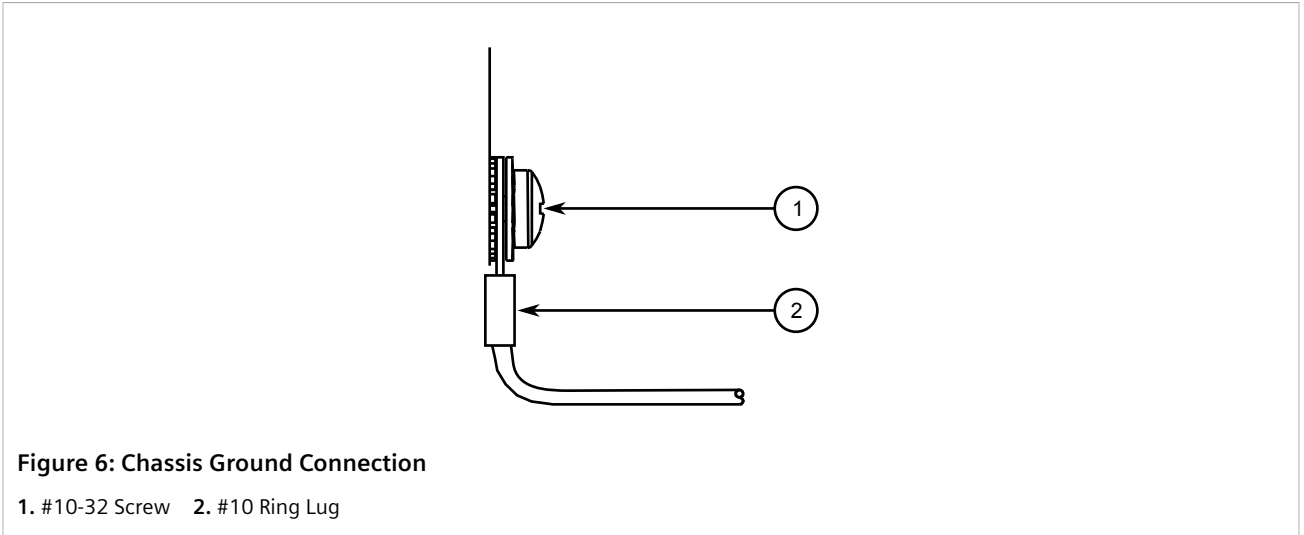

6. Install the safety cover over the terminal block.

### Section 2.5.2

## Connecting Low DC Power

To connect a low DC power supply to the device, do the following:



**CAUTION!**

*Electrical hazard – risk of damage to equipment. Do not connect AC power cables to a 12, 24 or 48 VDC power supply terminal block. Damage to the power supply may occur.*



**IMPORTANT!**

*When connecting the device to a DC power source, make sure the source provides only positive voltage.*

1. Connect the power supply terminal block to the device.

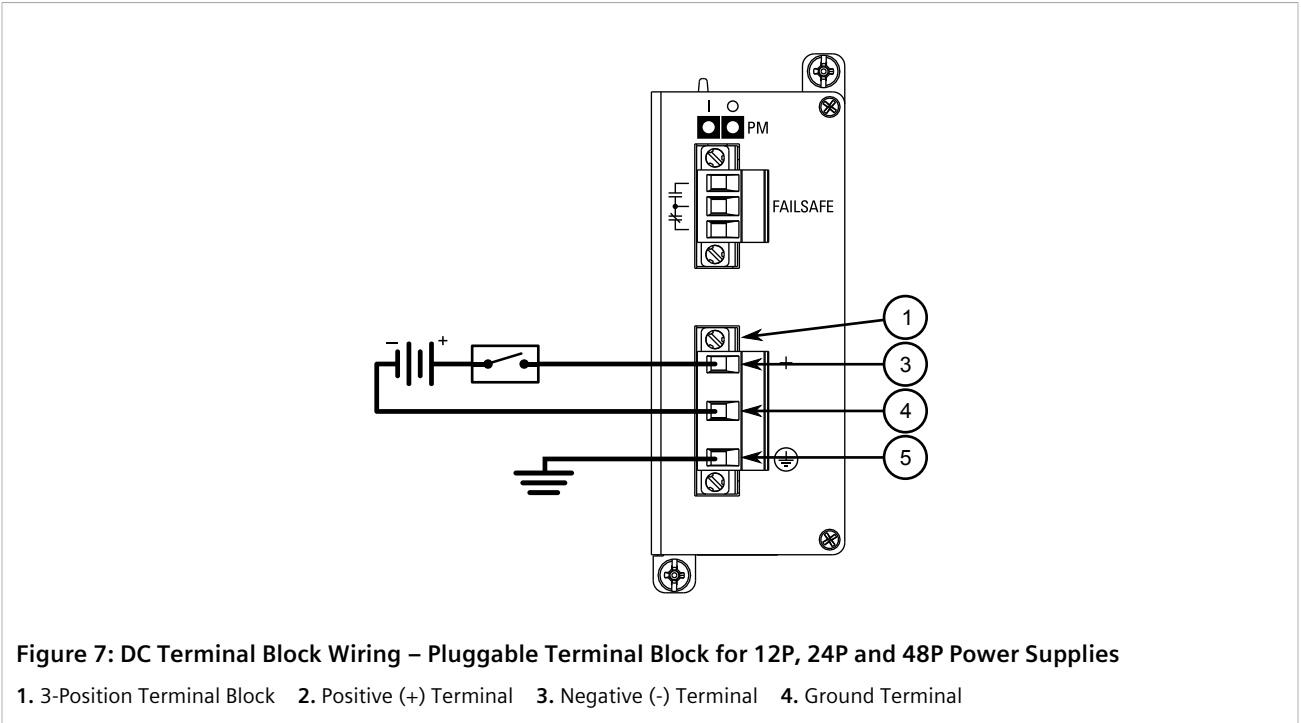

2. Connect the positive wire from the power source to the positive (+) terminal on the terminal block.
3. Connect the negative wire from the power source to the negative (-) terminal on the terminal block.
4. Using a braided wire or other appropriate grounding wire, connect the ground terminal to the chassis ground connection. The surge ground terminal is used as the ground conductor for all surge and transient suppression circuitry internal to the unit.
5. Using a #10 ring lug and #10-32 screw, secure the ground terminal on the power source to the chassis ground terminal on the device. Make sure the lug is tightened to 3.4 N·m (30 lbf·in).

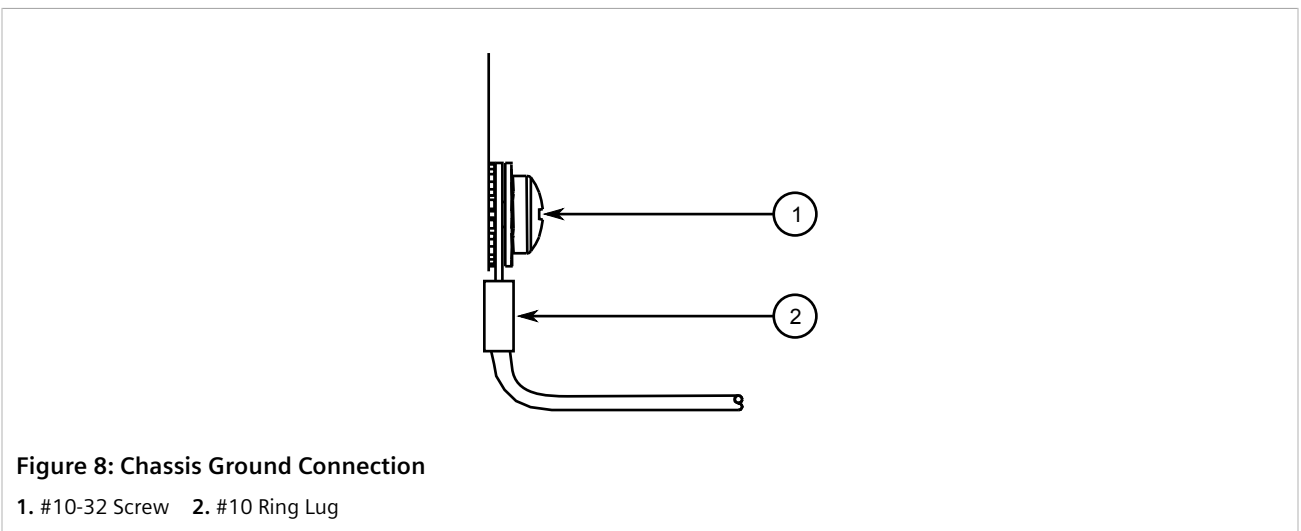

6. Install the safety cover over the terminal block. **This is mandatory for 48 VDC power supplies.**

# 3 Device Management

This section describes how to connect to and manage the device.

## CONTENTS

- [Section 3.1, "Connecting to the Device"](#)
- [Section 3.2, "Configuring the Device"](#)
- [Section 3.3, "Accessing the CompactFlash Card"](#)

### Section 3.1

## Connecting to the Device

The following describes the various methods for accessing the RUGGEDCOM ROX II console and Web interfaces on the device. For more detailed instructions, refer to the *RUGGEDCOM ROX II User Guide* for the RUGGEDCOM RX1510.

### » Serial Console and Management Ports

Connect a workstation directly to the serial console or management ports to access the boot-time control and RUGGEDCOM ROX II interfaces. The serial console port provides access to RUGGEDCOM ROX II's console interface, while the management port provides access to ROX II's console and Web interfaces.



#### IMPORTANT!

*The serial console and management (MGMT) ports are intended to be used only as temporary connections during initial configuration or troubleshooting.*

Connection to the console port is made using an RJ-45-to-DB9 console cable. The following is the pin-out for the console port:

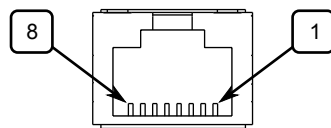

Figure 9: RJ-45 Console Port Pin Configuration

Pin		Name	Description
RJ-45 Male	DB9 Female		
1	6	DSR <sup>a</sup>	Data Set Ready
2	1	Reserved (Do Not Connect)	
3	4	DTR <sup>a</sup>	Data Terminal Ready
4	5	GND	Signal Ground
5	2	RxD	Receive Data (to DTE)
6	3	TxD	Transmit Data (from DTE)

Pin		Name	Description
RJ-45 Male	DB9 Female		
7	8	CTS <sup>b</sup>	Clear to Send
8	7	RTS <sup>b</sup>	Read to Send
	9	RI <sup>c</sup>	Ring Indicator

<sup>a</sup> The DSR, DCD and DTR pins are connected together internally.

<sup>b</sup> The CTS and RTS pins are connected together internally.

<sup>c</sup> RI is not connected.

For information about how to connect to the device via the serial console port, refer to the *RUGGEDCOM ROX II CLI User Guide* for the RUGGEDCOM RX1510.

For information about how to connect to the device via the management port, refer to either the *RUGGEDCOM ROX II Web Interface User Guide* or the *RUGGEDCOM ROX II CLI User Guide* for the RUGGEDCOM RX1510.

The management port is a 10/100Base-TX copper Ethernet port with an RJ-45 connector. The following is the pin-out for the management port:

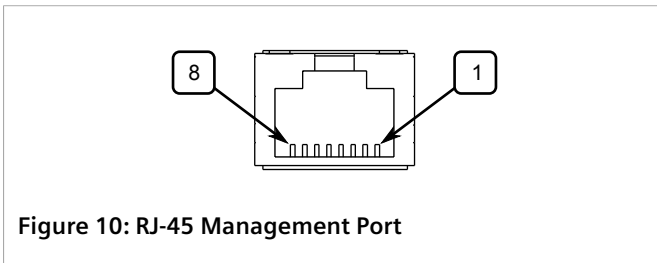

Figure 10: RJ-45 Management Port

Pin	Name	Description
1	RX+	Receive Data+
2	RX-	Receive Data-
3	TX+	Transmit Data+
4		Reserved (Do Not Connect)
5		Reserved (Do Not Connect)
6	TX-	Transmit Data-
7		Reserved (Do Not Connect)
8		Reserved (Do Not Connect)

## » Communication Ports

Connect any of the available Ethernet ports on the device to a management switch and access the RUGGEDCOM ROX II console and Web interfaces via the device's IP address. The factory default IP address for the RUGGEDCOM RX1510 is <https://192.168.0.2>.

For more information about available ports, refer to [Chapter 4, Modules](#).



### NOTE

Single-mode fiber ports only support Ultra Physical Contact (UPC) cable connectors.

## Section 3.2

## Configuring the Device

Once the device is installed and connected to the network, it must be configured. All configuration management is done via the RUGGEDCOM ROX II interface. For more information about configuring the device, refer to the *RUGGEDCOM ROX II User Guide* associated with the installed software release.

## Section 3.3

## Accessing the CompactFlash Card

The RUGGEDCOM RX1510 features a removable CompactFlash (CF) card that stores configuration files, firmware (active and backup versions), file-based feature keys and other system files.

**CAUTION!**

*Configuration hazard – risk of data corruption/loss. Do not remove or insert the CF card when the device is powered on.*

The CF card should only be removed in the following scenarios:

- The chassis is defective (with the exception of power and media modules)
- The CF card is deemed defective or corrupt
- The device is rendered non-functional due to a serious configuration error, data corruption, or hardware fault

**CAUTION!**

*Configuration hazard – risk of data corruption/loss. The following will void the warranty and potentially result in configuration data corruption/loss:*

- *Using a CF card not approved by Siemens for use with this device*
- *Removing the CF card in any scenario other than those described in this section*

### » Inserting the CF card

To insert the CF card into the device, do the following:

**IMPORTANT!**

*The device should only be powered on when the CF card is present.*

1. Make sure the device is powered down.
2. Remove the CF card access panel.
3. Insert the CF card into the slot until it is fully seated.

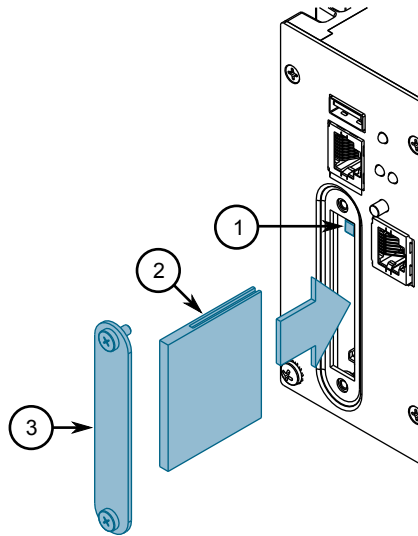

**Figure 11: Inserting the CF Card**

1. CompactFlash Card 2. Access Panel

4. Secure the CF card access panel to the chassis.

### » Removing the CF card

To remove the CF card from the device, do the following:

1. Make sure the device is powered down.
2. Remove the CF card access panel.

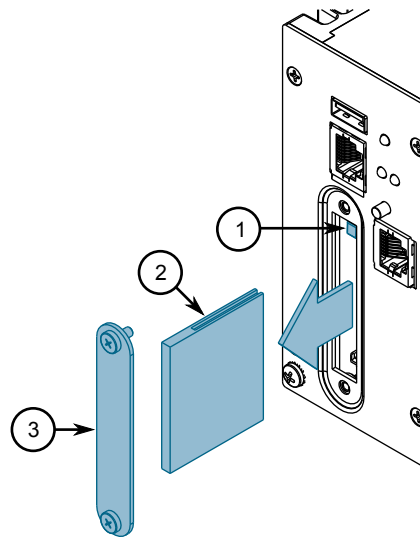

**Figure 12: Removing the CF Card**

1. Ejector Button 2. CompactFlash Card 3. Access Panel

3. Press the ejector button to the left of the CF card and then pull the card out.
4. Secure the CF card access panel to the chassis.



# 4 Modules

The RUGGEDCOM RX1510 features slots for up to two field-replaceable line modules, which can be used to expand and customize the capabilities of the device to suit specific applications. A variety of modules are available, each featuring a specific type of communication port: copper Ethernet, fiber optic Ethernet, SFP, WAN, cellular modem and DDS. The RUGGEDCOM APE (Application Processing Engine) line module, a utility-grade computing platform for running third-party applications directly from within the RUGGEDCOM RX1510, is also available.

Modules can be installed in any one of the available slots in the device chassis.

Use the RUGGEDCOM ROX II software to determine which ports are equipped on the device. For more information, refer to the *RUGGEDCOM ROX II User Guide* for the device.



### NOTE

*Only one T1/E1 WAN module and up to two DDS modules are supported.*

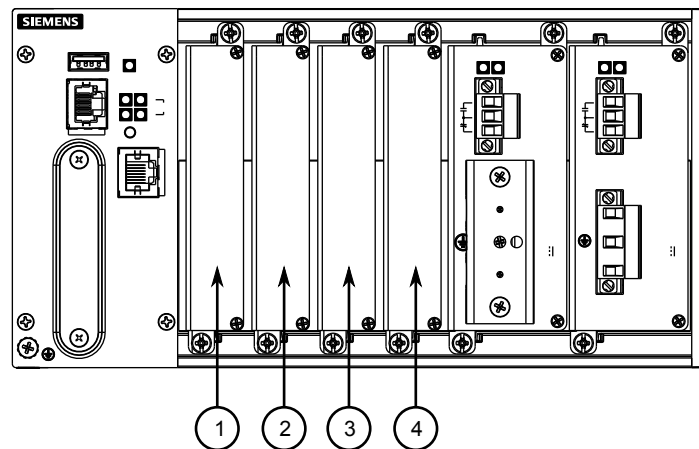

**Figure 13: Available Chassis Slots**

1. Slot 1 2. Slot 2 3. Slot 3 4. Slot 4

### CONTENTS

- [Section 4.1, "Available Modules"](#)
- [Section 4.2, "Installing/Removing Line Modules"](#)
- [Section 4.3, "Installing/Removing Power Modules"](#)

Section 4.1

# Available Modules

The following is a list of all power and line modules available for use in the RUGGEDCOM RX1510. For more information about individual modules, refer to the [RUGGEDCOM RX1500 Series Modules Catalog](https://support.industry.siemens.com/cs/ca/en/view/109747072) [https://support.industry.siemens.com/cs/ca/en/view/109747072].

## » Power Supply Modules

### RUGGEDCOM RX1500PN PS 12

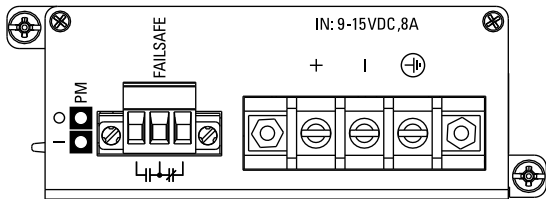

#### Specifications

Input Range: 9 to 15 VDC  
Terminal Type: Screw

#### Article Numbers

6GK6015-0AL17-0AA0 (Standard)  
6GK6015-0AL17-0AA1 (Conformal Coated)

### RUGGEDCOM RX1500PN PS 12P

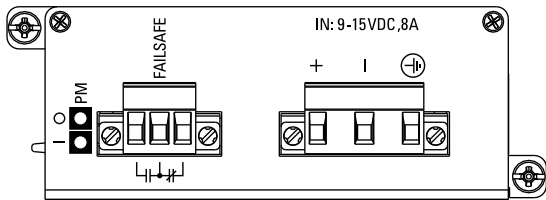

#### Specifications

Input Range: 9 to 15 VDC  
Terminal Type: Pluggable

#### Article Numbers

6GK6015-0AL18-0AA0 (Standard)  
6GK6015-0AL18-0AA1 (Conformal Coated)

### RUGGEDCOM RX1500PN PS 24

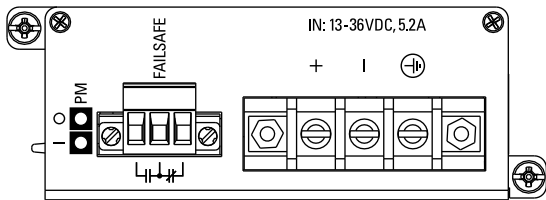

#### Specifications

Input Range: 13 to 36 VDC  
Terminal Type: Screw

#### Article Numbers

6GK6015-0AL11-0AA0 (Standard)  
6GK6015-0AL11-0AA1 (Conformal Coated)

### RUGGEDCOM RX1500PN PS 24P

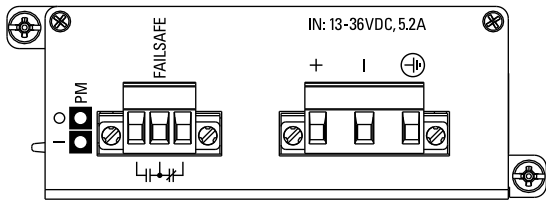

#### Specifications

Input Range: 13 to 36 VDC  
Terminal Type: Pluggable

#### Article Numbers

6GK6015-0AL14-0AA0 (Standard)  
6GK6015-0AL14-0AA1 (Conformal Coated)

**RUGGEDCOM RX1500PN PS 48**

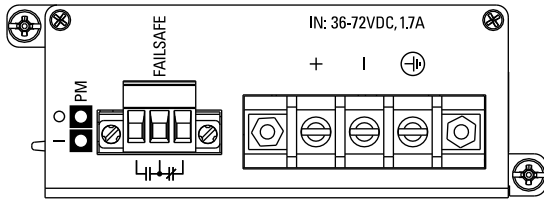

**Specifications**

Input Range: 36 to 72 VDC  
Terminal Type: Screw

**Article Numbers**

6GK6015-0AL12-0AA0  
(Standard)  
6GK6015-0AL12-0AA1  
(Conformal Coated)

**RUGGEDCOM RX1500PN PS 48P**

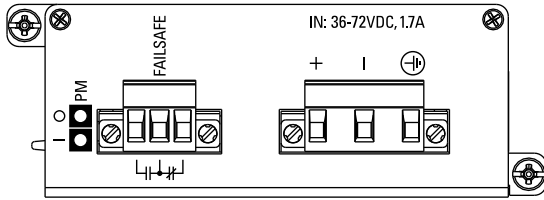

**Specifications**

Input Range: 36 to 72 VDC  
Terminal Type: Pluggable

**Article Numbers**

6GK6015-0AL15-0AA0  
(Standard)  
6GK6015-0AL15-0AA1  
(Conformal Coated)

**RUGGEDCOM RX1500PN PS HI**

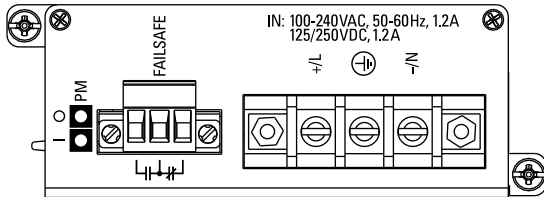

**Specifications**

Input Range: 88 to 300 VDC or  
85 to 264 VAC  
Terminal Type: Screw

**Article Numbers**

6GK6015-0AL13-0AA0  
(Standard)  
6GK6015-0AL13-0AA1  
(Conformal Coated)

**RUGGEDCOM RX1500PN PS HIP**

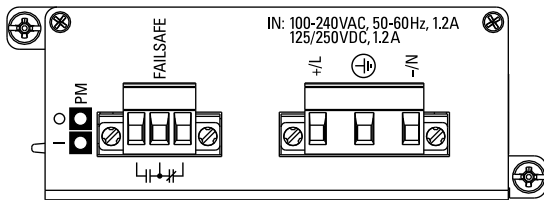

**Specifications**

Input Range: 88 to 300 VDC or  
85 to 264 VAC  
Terminal Type: Screw

**Article Numbers**

6GK6015-0AL16-0AA0  
(Standard)  
6GK6015-0AL16-0AA1  
(Conformal Coated)

» **Copper Ethernet Modules**

**RUGGEDCOM RX1500PN LM CG01**

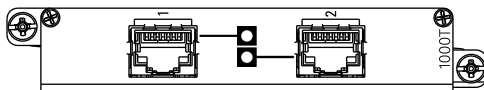

**Specifications**

Ports: 2  
Speed: 1000 Mbps  
Interface: TX  
Port Type: RJ45  
Distance: 100 m (328 ft)

**Article Numbers**

6GK6015-0AL20-0FC0  
(Standard)  
6GK6015-0AL20-0FC1  
(Conformal Coated)

**RUGGEDCOM RX1500PN LM CG03**

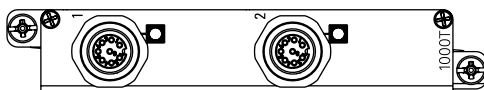

**Specifications**

Ports: 2  
Speed: 1000 Mbps  
Interface: TX  
Port Type: M12 (8-Pin, A-Coded)  
Distance: 100 m (328 ft)

**Article Numbers**

6GK6015-0AL20-0PB0  
(Standard)  
6GK6015-0AL20-0PB1  
(Conformal Coated)

**RUGGEDCOM RX1500PN LM CG03B**

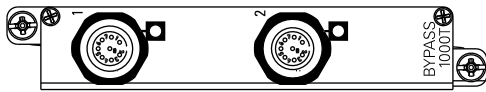

**Specifications**

Ports: 2  
Speed: 1000 Mbps  
Interface: TX  
Port Type: M12 (8-Pin, A-Coded, Controlled Bypass)  
Distance: 100 m (328 ft)

**Article Numbers**

6GK6015-0AL20-0PE0 (Standard)  
6GK6015-0AL20-0PE1 (Conformal Coated)

**RUGGEDCOM RX1500PN LM X CG04**

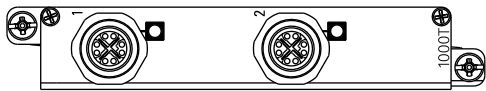

**Specifications**

Ports: 2  
Speed: 1000 Mbps  
Interface: TX  
Port Type: M12 (8-pin, X-Coded)  
Distance: 100 m (328 ft)

**Article Numbers**

6GK6015-0AL20-0PH0 (Standard)  
6GK6015-0AL20-0PH1 (Conformal Coated)

**RUGGEDCOM RX1500PN LM X CG04B**

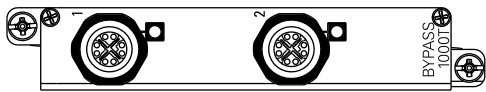

**Specifications**

Ports: 2  
Speed: 1000 Mbps  
Interface: TX  
Port Type: M12 (8-pin, X-Coded, Controlled Bypass)  
Distance: 100 m (328 ft)

**Article Numbers**

6GK6015-0AL20-0PJ0 (Standard)  
6GK6015-0AL20-0PJ1 (Conformal Coated)

**RUGGEDCOM RX1500PN LM 4TX03**

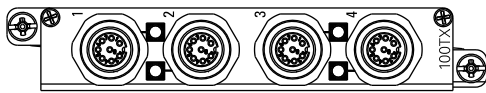

**Specifications**

Ports: 4  
Speed: 100 Mbps  
Interface: TX  
Port Type: M12 (4-Pin, A-Coded)  
Distance: 100 m (328 ft)

**Article Numbers**

6GK6015-0AL20-0PC0 (Standard)  
6GK6015-0AL20-0PC1 (Conformal Coated)

**RUGGEDCOM RX1500PN LM 4TX03B**

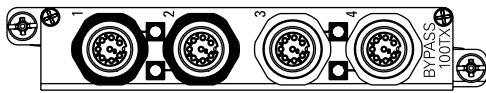

**Specifications**

Ports: 4  
Speed: 100 Mbps  
Interface: TX  
Port Type: M12 (8-Pin, A-Coded, Controlled Bypass)  
Distance: 100 m (328 ft)

**Article Numbers**

6GK6015-0AL20-0PF0 (Standard)  
6GK6015-0AL20-0PF1 (Conformal Coated)

**RUGGEDCOM RX1500PN LM 4TX04**

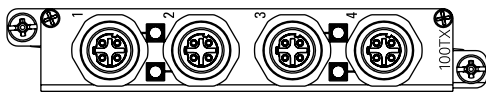

**Specifications**

Ports: 4  
Speed: 100 Mbps  
Interface: TX  
Port Type: M12 (4-Pin, D-Coded)  
Distance: 100 m (328 ft)

**Article Numbers**

6GK6015-0AL20-0PD0 (Standard)  
6GK6015-0AL20-0PD1 (Conformal Coated)

**RUGGEDCOM RX1500PN LM 4TX04B**

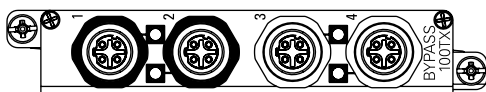

**Specifications**

Ports: 4  
Speed: 100 Mbps  
Interface: TX  
Port Type: M12 (4-Pin, A-Coded, Controlled Bypass)  
Distance: 100 m (328 ft)

**Article Numbers**

6GK6015-0AL20-0PG0 (Standard)  
6GK6015-0AL20-0PG1 (Conformal Coated)

**RUGGEDCOM RX1500PN LM 6TX01**

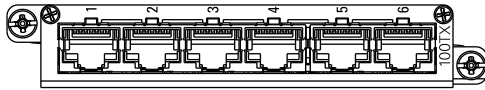

**Specifications**

Ports: 6  
Speed: 100 Mbps  
Interface: TX  
Port Type: RJ45  
Distance: 100 m (328 ft)

**Article Numbers**

6GK6015-0AL20-ONB0 (Standard)  
6GK6015-0AL20-ONB1 (Conformal Coated)

» **Fiber Optic Ethernet Modules**

**RUGGEDCOM RX1500PN LM 4FX11**

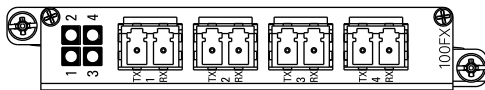

**Specifications**

Mode: MM  
Speed: 100 Mbps  
Interface: FX  
Wavelength: 1300 nm  
Ports: 4  
Port Type: LC  
Distance: 2 km (1.2 mi)

**Article Numbers**

6GK6015-0AL20-0BC0 (Standard)  
6GK6015-0AL20-0BC1 (Conformal Coated)

**RUGGEDCOM RX1500PN LM FL01**

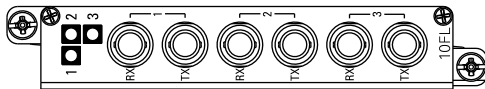

**Specifications**

Mode: MM  
Speed: 10/100 Mbps  
Interface: FL/SX  
Wavelength: 820 nm  
Ports: 3  
Port Type: ST  
Distance: 2 km (1.2 mi)

**Article Numbers**

6GK6015-0AL20-0BD0 (Standard)  
6GK6015-0AL20-0BD1 (Conformal Coated)

**RUGGEDCOM RX1500PN LM FG03**

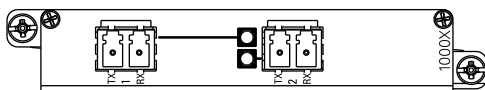

**Specifications**

Mode: SM  
Speed: 1000 Mbps  
Interface: LX  
Wavelength: 820 nm  
Ports: 4  
Port Type: LC  
Distance: 10 km (6.2 mi)

**Article Numbers**

6GK6015-0AL20-0EC0 (Standard)  
6GK6015-0AL20-0EC1 (Conformal Coated)

**RUGGEDCOM RX1500PN LM FG50**

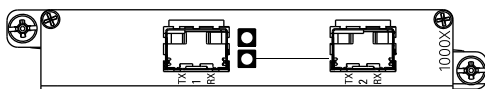

**Specifications**

SFP Sockets: 2  
Speed: 1000 Mbps

**Article Numbers**

6GK6015-0AL20-0JB0 (Standard)  
6GK6015-0AL20-0JB1 (Conformal Coated)

**RUGGEDCOM RX1500PN LM FX50**

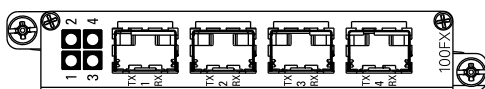

**Specifications**

SFP Sockets: 4  
Speed: 100 Mbps

**Article Numbers**

6GK6015-0AL20-0JC0 (Standard)  
6GK6015-0AL20-0JC1 (Conformal Coated)

**RUGGEDCOM RX1500PN LM 6FX50**

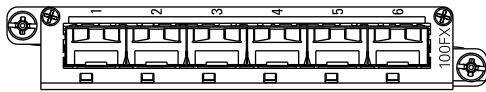

**Specifications**

SFP Sockets: 6  
Speed: 100 Mbps

**Article Numbers**

6GK6015-0AL20-OJD0 (Standard)  
6GK6015-0AL20-OJD1 (Conformal Coated)

» **WAN Modules**

**RUGGEDCOM RX1500PN LM S01**

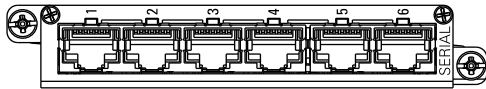

**Specifications**

Standard: RS232/RS422/RS485  
Ports: 6  
Port Type: RJ45

**Article Numbers (Standard)**

6GK6015-0AL20-OKB0 (Standard)  
6GK6015-0AL20-OKB1 (Conformal Coated)

**RUGGEDCOM RX1500PN LM TC1**

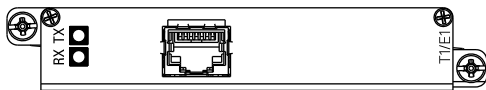

**Specifications**

Interface: T1/E1  
Ports: 1  
Port Type: RJ48C

**Article Numbers (Standard)**

6GK6015-0AL20-0MB0 (Standard)  
6GK6015-0AL20-0MB1 (Conformal Coated)

**RUGGEDCOM RX1500PN LM TC2**

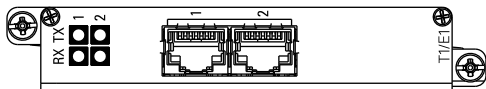

**Specifications**

Interface: T1/E1  
Ports: 2  
Port Type: RJ48C

**Article Numbers (Standard)**

6GK6015-0AL20-0MCO (Standard)  
6GK6015-0AL20-0MC1 (Conformal Coated)

**RUGGEDCOM RX1500PN LM TC4**

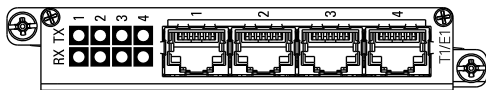

**Specifications**

Interface: T1/E1  
Ports: 4  
Port Type: RJ48C

**Article Numbers (Standard)**

6GK6015-0AL20-0MD0 (Standard)  
6GK6015-0AL20-0MD1 (Conformal Coated)

**RUGGEDCOM RX1500PN LM E02**

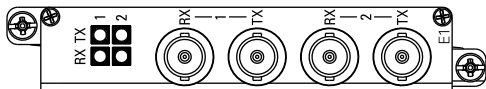

**Specifications**

Interface: E1  
Ports: 2  
Port Type: BNC (75 Ω)

**Article Numbers (Standard)**

6GK6015-0AL20-0HCO (Standard)  
6GK6015-0AL20-0HC1 (Conformal Coated)

**RUGGEDCOM RX1500PN LM D02**



**Specifications**

Speed: 56 kbps (Master/Slave) or 64 kbps (Slave)  
Ports: 1  
Port Type: RJ48S

**Article Numbers (Standard)**

6GK6015-0AL20-0LB0 (Standard)  
6GK6015-0AL20-0LB1 (Conformal Coated)

» **Cellular Modem Modules**

**RUGGEDCOM RX1500PN LM W11**

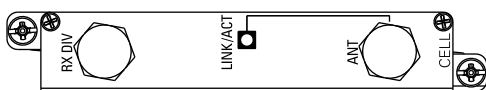

**Specifications**

Services: GSM/EDGE/HSPA+  
Region: North America (AT&T)  
Port Type: 50 Ω SMA  
Antennas: 1 x GSM/EDGE/HSPA+,  
1 x Receive Diversity (Secondary)

**Article Numbers (Standard)**

6GK6015-0AL20-0WB0 (Standard)  
6GK6015-0AL20-0WB1 (Conformal Coated)

**RUGGEDCOM RX1500PN LM W12**

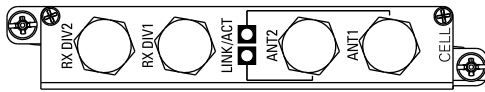

SIM: Dual Mini-SIM (2FF)

**Specifications**

Services: GSM/EDGE/HSPA+  
Region: North America (AT&T),  
European Union, Australia  
Port Type: 50 Ω SMA  
Antennas: 2 x GSM/EDGE/HSPA+,  
2 x Receive Diversity (Secondary)  
SIM: Dual Mini-SIM (2FF)

**Article Numbers (Standard)**

6GK6015-0AL20-OWCO  
(Standard)  
6GK6015-0AL20-OWC1  
(Conformal Coated)

**RUGGEDCOM RX1500PN LM W21**

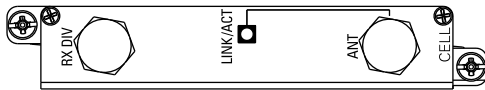

**Specifications**

Services: EVDO Rev A  
Region: North America (Verizon)  
Port Type: 50 Ω SMA  
Antennas: 1 x EVDO Rev A, 1 x  
Receive Diversity (Secondary)  
SIM: Dual Mini-SIM (2FF)

**Article Numbers (Standard)**

6GK6015-0AL20-OWDO  
(Standard)  
6GK6015-0AL20-OWD1  
(Conformal Coated)

**RUGGEDCOM RX1500PN LM W22**

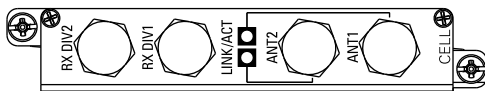

**Specifications**

Services: EVDO Rev A  
Region: North America (Verizon)  
Port Type: 50 Ω SMA  
Antennas: 2 x EVDO Rev A, 2 x  
Receive Diversity (Secondary)  
SIM: Dual Mini-SIM (2FF)

**Article Numbers (Standard)**

6GK6015-0AL20-OWE0  
(Standard)  
6GK6015-0AL20-OWE1  
(Conformal Coated)

**RUGGEDCOM RX1500PN LM W32**

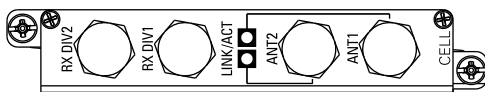

**Specifications**

Services: EVDO Rev A  
Region: North America (Verizon)  
Port Type: 50 Ω SMA  
Antennas: 1 x GSM/EDGE/HSPA  
+, 1 x EVDO Rev A, 2 x Receive  
Diversity (Secondary)  
SIM: Dual Mini-SIM (2FF)

**Article Numbers (Standard)**

6GK6015-0AL20-OWF0  
(Standard)  
6GK6015-0AL20-OWF1  
(Conformal Coated)

**RUGGEDCOM RX1500PN LM W41**

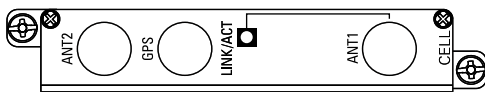

**Specifications**

Services: 4G LTE/HSPA+/HSDPA/  
HSUPA/DC-HSPA+/UMTS/WCDMA/  
EDGE/GPRS/GSM/GNSS  
Region: European Union  
Port Type: 50 Ω SMA  
Antennas: 1 x LTE Main, 1 x LTE  
MIMO, 1 x GPS  
SIM: Dual Mini-SIM (2FF)

**Article Numbers (Standard)**

6GK6015-0AL20-OWG0  
(Standard)  
6GK6015-0AL20-OWG1  
(Conformal Coated)

**RUGGEDCOM RX1500PN LM W51**

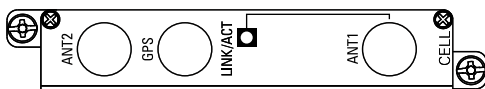

**Specifications**

Services: 4G LTE/HSPA+/HSDPA/  
HSUPA/DC-HSPA+/UMTS/WCDMA/  
EDGE/GPRS/GSM/CDMA/EVDO/  
GNSS  
Region: North America (AT&T,  
Rogers, Bell, Telus)  
Port Type: 50 Ω SMA  
Antennas: 1 x LTE Main, 1 x LTE  
MIMO, 1 x GPS

**Article Numbers (Standard)**

6GK6015-0AL20-OWHO  
(Standard)  
6GK6015-0AL20-OWH1  
(Conformal Coated)

**RUGGEDCOM RX1500PN LM W61**

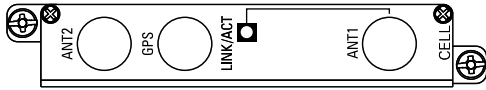

SIM: Dual Mini-SIM (2FF)

**Specifications**

Services: 4G LTE/HSPA+/CDMA/  
EVDO/GPS/GNSS

Region: North America (Verizon,  
Sprint)

Port Type: 50 Ω SMA

Antennas: 1 x LTE Main, 1 x LTE  
MIMO, 1 x GPS

SIM: Dual Mini-SIM (2FF)

**Article Numbers (Standard)**

6GK6015-0AL20-0WJ0  
(Standard)

6GK6015-0AL20-0WJ1  
(Conformal Coated)

**RUGGEDCOM RX1500PN LM W81**

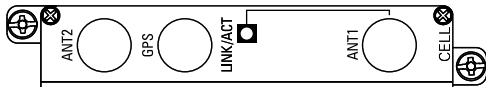

**Specifications**

Services: 4G LTE/HSPA+/EDGE/  
GPRS/GSM/UMTS/GNSS

Region: Asia-Pacific

Port Type: 50 Ω SMA

Antennas: 1 x LTE Main, 1 x LTE  
MIMO, 1 x GPS

SIM: Dual Mini-SIM (2FF)

**Article Numbers (Standard)**

6GK60150AL200WK0 (Standard)

6GK60150AL200WK1  
(Conformal Coated)

» **RUGGEDCOM APE Modules**

**RUGGEDCOM RX1500PN LM APE1402**

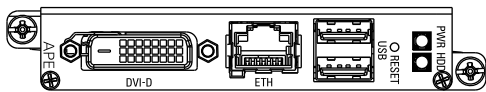

**Specifications**

Operating System: Debian Linux®

Processor: Intel Atom E660 1.3  
GHz, 512 KB L2 Cache

RAM: 2 GB DDR2, 800 MHz, 32-  
bit

Disk: 8 GB SATA, Solid State

Networking: Realtek RTL8111,  
RJ45 Gigabit Ethernet Interface

USB: 2 x USB 2.1<sup>a</sup>

Video: Intel 4108 Graphics  
Processor, DVI-D

**Article Numbers (Standard)**

6GK6015-0AL20-0GB0  
(Standard)

6GK6015-0AL20-0GB1  
(Conformal Coated)

**RUGGEDCOM RX1500PN LM APE1402W7**

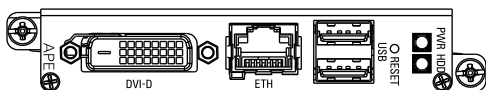

**Specifications**

Operating System: Windows®  
Embedded Standard 7

Processor: Intel Atom E660 1.3  
GHz, 512 KB L2 Cache

RAM: 2 GB DDR2, 800 MHz, 32-  
bit

Disk: 8 GB SATA, Solid State

Networking: Realtek RTL8111,  
RJ45 Gigabit Ethernet Interface

USB: 2 x USB 2.1<sup>a</sup>

Video: Intel 4108 Graphics  
Processor, DVI-D

**Article Numbers (Standard)**

6GK6015-0AL20-0GC0  
(Standard)

6GK6015-0AL20-0GC1  
(Conformal Coated)

**RUGGEDCOM RX1500PN LM APE1404**

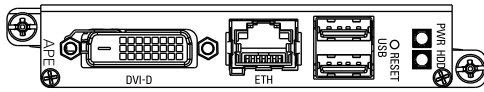

**Specifications**

Operating System: Debian Linux®  
 Processor: Intel Atom E660T 1.3 GHz, 512 KB L2 Cache  
 RAM: 2 GB DDR2, 800 MHz, 32-bit  
 Disk: 16 GB SATA, Solid State  
 Networking: Realtek RTL8111, RJ45 Gigabit Ethernet Interface  
 USB: 2 x USB 2.1<sup>a</sup>  
 Video: Intel 4108 Graphics Processor, DVI-D

**Article Numbers (Standard)**

6GK6015-0AL20-0GD0 (Standard)  
 6GK6015-0AL20-0GD1 (Conformal Coated)

**RUGGEDCOM RX1500PN LM APE1404W7**

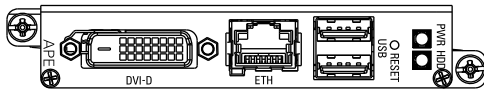

**Specifications**

Operating System: Windows® Embedded Standard 7  
 Processor: Intel Atom E660T 1.3 GHz, 512 KB L2 Cache  
 RAM: 2 GB DDR2, 800 MHz, 32-bit  
 Disk: 16 GB SATA, Solid State  
 Networking: Realtek RTL8111, RJ45 Gigabit Ethernet Interface  
 USB: 2 x USB 2.1<sup>a</sup>  
 Video: Intel 4108 Graphics Processor, DVI-D

**Article Numbers (Standard)**

6GK6015-0AL20-0GE0 (Standard)  
 6GK6015-0AL20-0GE1 (Conformal Coated)

**RUGGEDCOM RX1500PN LM APE1404CKP**

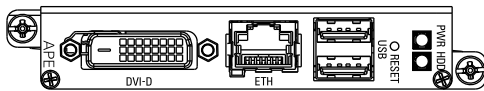

**Specifications**

Operating System: Check Point GAI™ OS  
 Processor: Intel Atom E660T 1.3 GHz, 512 KB L2 Cache  
 RAM: 2 GB DDR2, 800 MHz, 32-bit  
 Disk: 16 GB SATA, Solid State  
 Networking: Realtek RTL8111, RJ45 Gigabit Ethernet Interface  
 USB: 2 x USB 2.1<sup>a</sup>  
 Video: Intel 4108 Graphics Processor, DVI-D

**Article Numbers (Standard)**

6GK6015-0AL20-0GF0 (Standard)  
 6GK6015-0AL20-0GF1 (Conformal Coated)

<sup>a</sup> Maximum combined USB device power consumption is 500 mA at 5 V.

» **Blank Modules**

**RUGGEDCOM RX1500PN PS XXP**

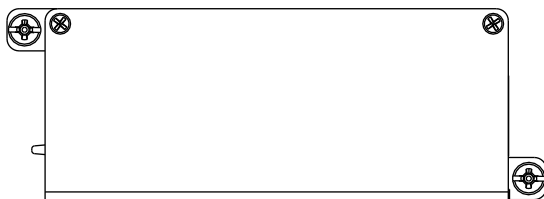

**Specifications**

—

**Article Numbers**

6GK6015-0AL10-0AA0 (Standard)  
 6GK6015-0AL10-0AA1 (Conformal Coated)

RUGGEDCOM RX1500PN LM Blank

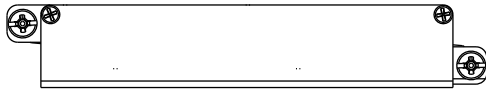

Specifications

—

Article Numbers

6GK6015-0AL20-0AA0  
(Standard)

6GK6015-0AL20-0AA1  
(Conformal Coated)

Section 4.2

## Installing/Removing Line Modules

Upon installing a new line module in the device, all features associated with the module are available in RUGGEDCOM ROX II. For more information, refer to the *RUGGEDCOM ROX II User Guide* for the RUGGEDCOM RX1510.

Once a line module is removed, all the features associated with the module are hidden or disabled in RUGGEDCOM ROX II.



**CAUTION!**

*Electrical hazard – risk of power failure. Do not install more than two RUGGEDCOM APE modules. Installing more than two of this type of module can lead to power fluctuations and irregular shut downs.*



**IMPORTANT!**

*Only one WAN line module is supported per chassis.*



**CAUTION!**

*Contamination hazard – risk of equipment damage. Prevent the ingress of water, dirt and other debris that may lead to premature equipment failure. Always make sure slots are not left empty and open ports are protected with plugs or covers.*

### » Removing a Module

To remove a line module, do the following:

1. [Optional] If the device is installed in a rack, remove it from the rack.
2. Loosen the screws that secure the module.
3. Pull the module from the chassis to disconnect it.

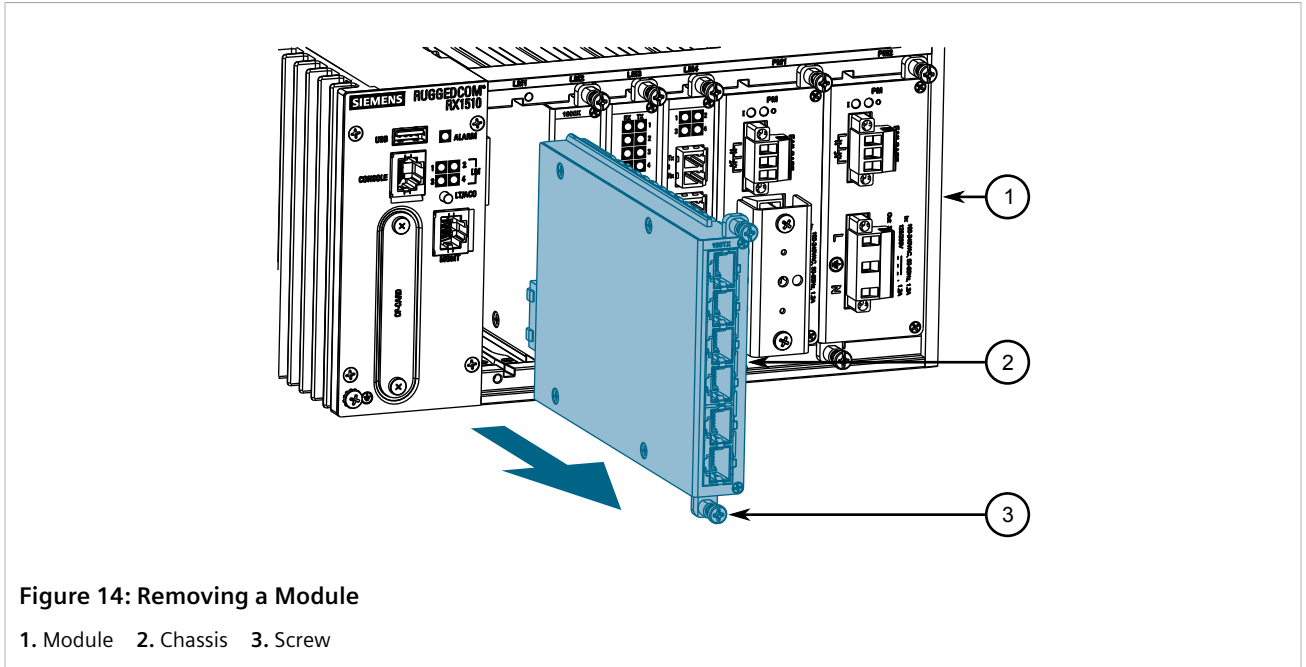

4. Install a new module or a blank module (to prevent the ingress of dust and dirt).
5. [Optional] If necessary, install the device in the rack.

### » Installing a Module

To install a line module, do the following:

1. [Optional] If the device is installed in a rack, remove it from the rack.
2. Remove the current module from the slot.
3. Insert the new module into the slot.

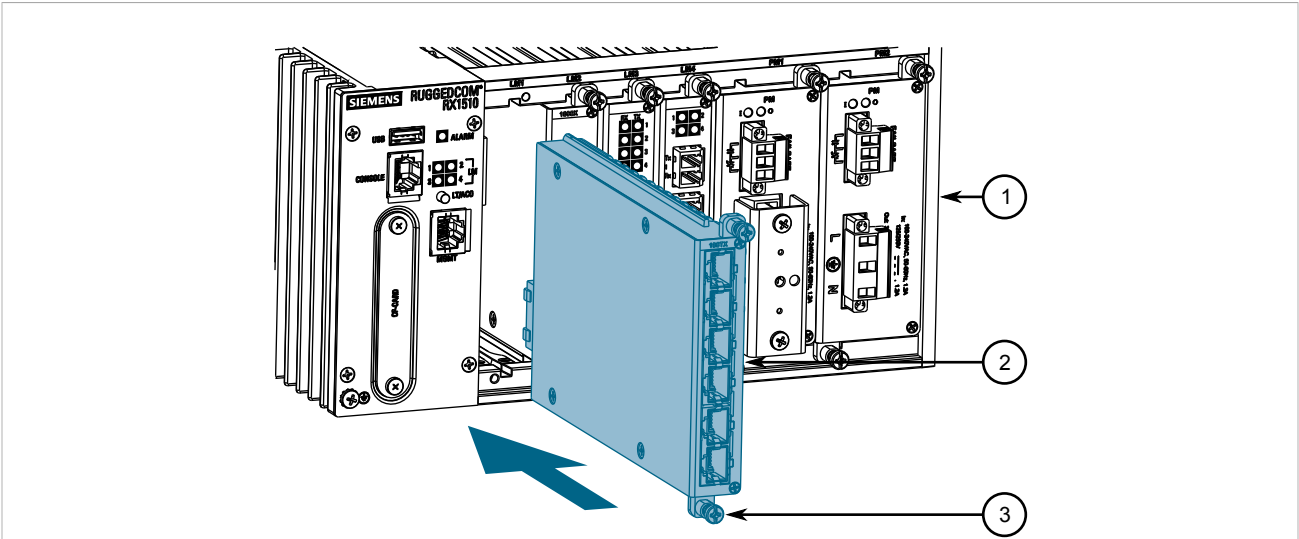

**Figure 15: Installing a Module**

1. Module 2. Chassis 3. Screw

4. Tighten the screws to secure the module.
5. [Optional] If necessary, install the device in the rack.

Section 4.3

## Installing/Removing Power Modules

The RUGGEDCOM RX1510 supports dual redundant power supply modules.

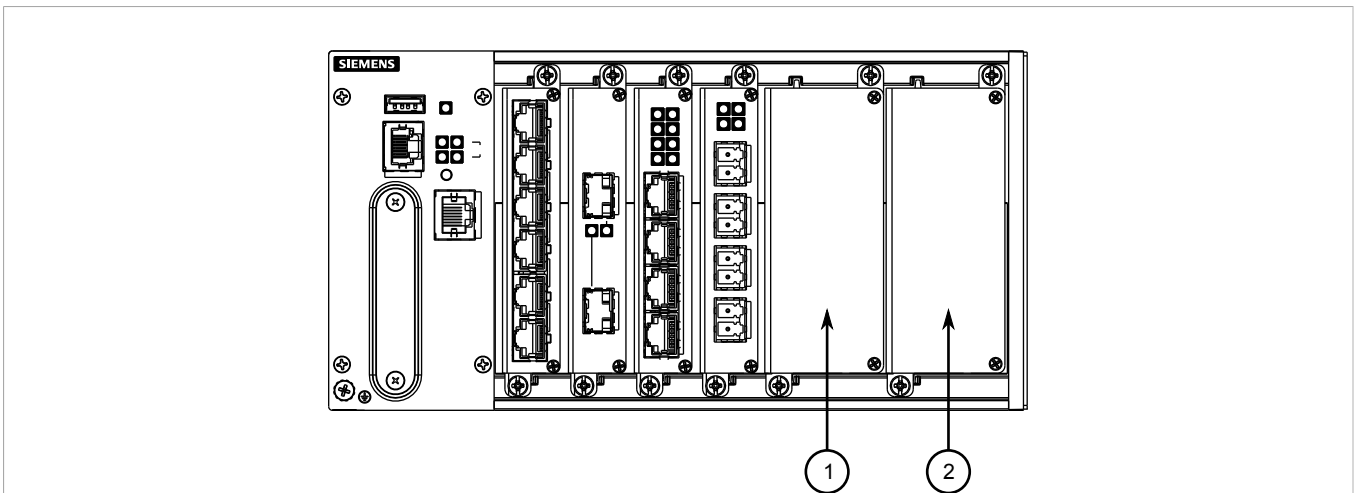

**Figure 16: Power Modules**

1. Slot PS1 2. Slot PS2



**CAUTION!**

Contamination hazard – risk of equipment damage. Prevent the ingress of water, dirt and other debris that may lead to premature equipment failure. Always make sure slots are not left empty.



**NOTE**

Power modules are hot swappable. When installing/removing a power module, it is not necessary to turn off power to the redundant power module.

## » Removing a Power Module

To remove a power module, do the following:



**DANGER!**

Electrocution hazard – risk of serious personal injury or death. Make sure power to the module is turned off before servicing the power supply terminal.

1. Turn off power to the module.
2. Loosen the screws that secure the module to the chassis until the module can be removed.

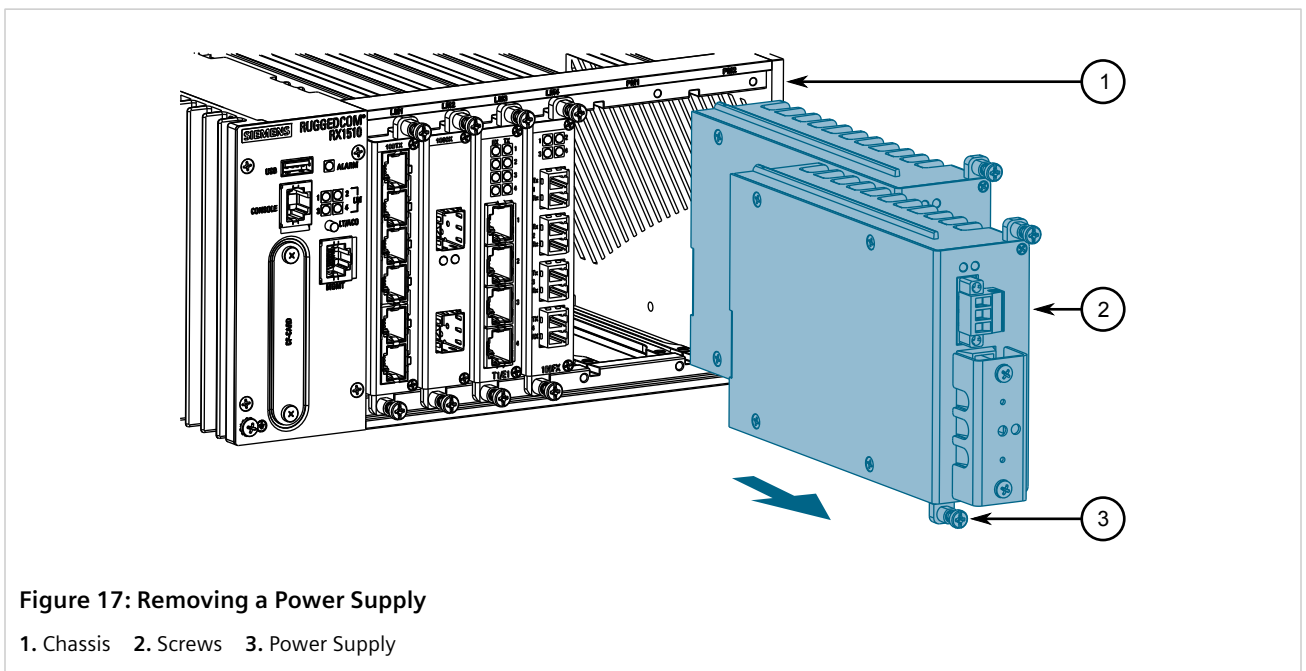

3. Slide the module out of the chassis.
4. Disconnect the power supply wiring from the terminal block. Alternatively, for convenience, remove the terminal block with the wiring still connected and set it aside to be connected later to the new module.
5. Install a new or blank module to prevent the ingress of dust and dirt.

## » Installing a Power Module

To install a power module, do the following:

1. If equipped, remove the existing module.

2. If applicable, connect the supplied terminal block to the module or connect the terminal block from the previous module.
3. Confirm or connect the wiring from the power supply to the module. For more information, refer to [Section 2.5, "Connecting Power"](#).
4. Insert the module into the empty slot.

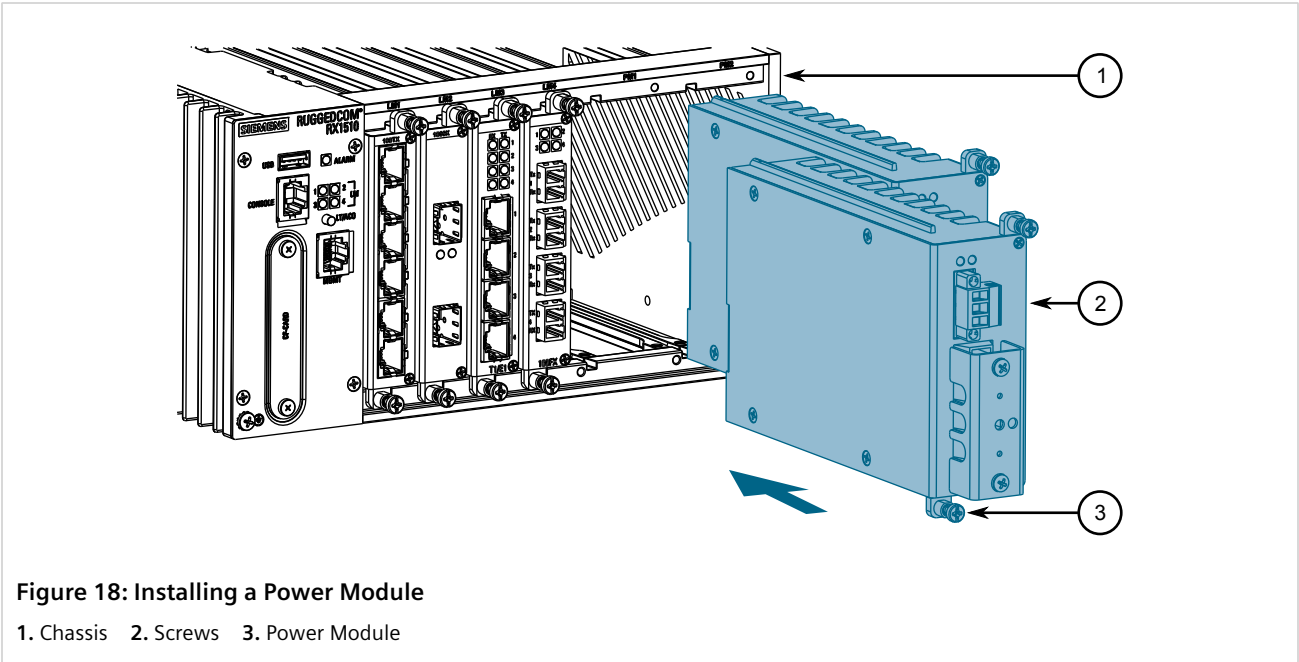

5. Hand-tighten the screws to secure the power module to the chassis.
6. Turn on power to the device and confirm the module is receiving and supplying power. This is indicated by the LEDs on the module.

LED	State	Description
O	Green	The module is supplying power
I	Green	The module is receiving power

# 5 Technical Specifications

This section provides important technical specifications related to the device.

## CONTENTS

- [Section 5.1, "Power Supply Specifications"](#)
- [Section 5.2, "Failsafe Relay Specifications"](#)
- [Section 5.3, "Operating Environment"](#)
- [Section 5.4, "Mechanical Specifications"](#)
- [Section 5.5, "Dimension Drawings"](#)

## Section 5.1

# Power Supply Specifications



### NOTE

When determining cable lengths, make sure the minimum input voltage for the power supply is provided at the power source.

Power Supply Type	Input Range		Internal Fuse Rating	Maximum Power Consumption <sup>a</sup>	Insulation
	Min	Max			
HI	88 VDC	300 VDC	3.15 A(T) <sup>b</sup>	65 W	2800 VDC for 1 minute
	85 VAC	264 VAC			
HIP	88 VDC	300 VDC	3.15 A(T) <sup>b</sup>	65 W	
	85 VAC	264 VAC			
24	13 VDC	36 VDC	10 A(T) <sup>b</sup>	63.5 W	1500 VDC for 1 minute
24P					
48	36 VDC	72 VDC	3.15 A(T) <sup>b</sup>	60 W	
48P					
12	9 VDC	15 VDC	12 A	67 W	1500 VAC or 2121 VDC for 1 minute
12P					

<sup>a</sup> Power consumption varies based on the device configuration.

<sup>b</sup> (T) denotes time-delay fuse.

Section 5.2

## Failsafe Relay Specifications

Maximum Switching Voltage	Rated Switching Current	Isolation
30 VDC	5 A	2800 VDC for 1 minute
250 VAC	6.25 A	

Section 5.3

## Operating Environment

The RUGGEDCOM RX1510 is rated to operate under the following environmental conditions.



**IMPORTANT!**

*Temperature limits for select line modules may differ from that which can be withstood by the RUGGEDCOM RX1510. Make sure the selected modules are rated for the expected environmental conditions before deployment. For more information, refer to the RUGGEDCOM RX1510 Series Modules Catalog.*

Ambient Operating Temperature <sup>cd</sup>	-40 to 85 °C (-40 to 185 °F)
Ambient Storage Temperature	-40 to 85 °C (-40 to 185 °F)
Ambient Relative Humidity <sup>e</sup>	5% to 95%
Maximum Altitude	2000 m (6562 ft)

<sup>c</sup> Maximum ambient operating temperature is 70 °C (158 °F) when the device is installed along with Underwriter Laboratories (UL) listed devices.

<sup>d</sup> Measured from a 30 cm (12 in) radius surrounding the center of the enclosure.

<sup>e</sup> Non-condensing.

Section 5.4

## Mechanical Specifications

Weight	Approximately 5.0 kg (11 lb)
Ingress Protection	IP40
Enclosure	Aluminum

Section 5.5

## Dimension Drawings



**NOTE**

*All dimensions are in millimeters, unless otherwise stated.*

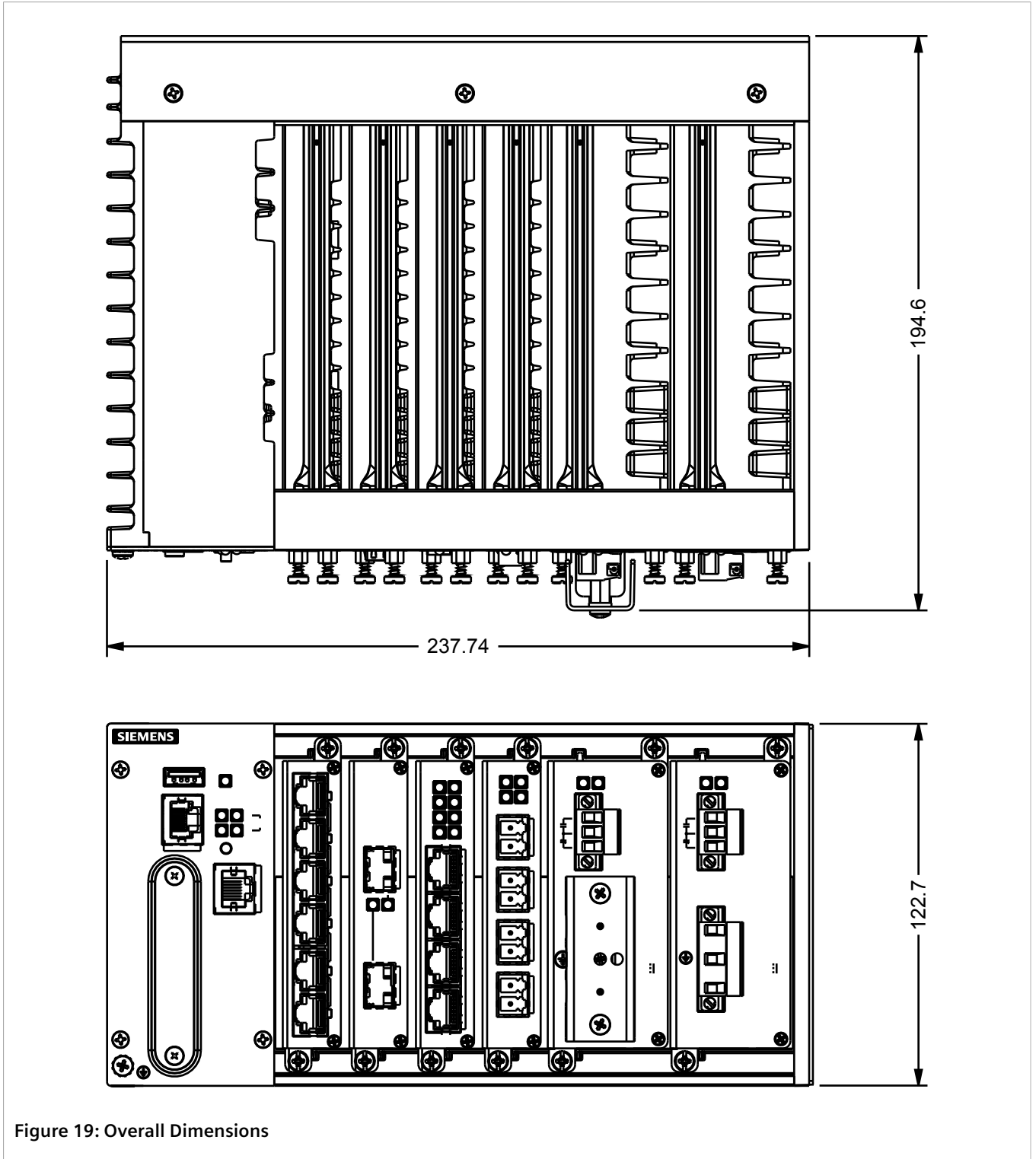

Figure 19: Overall Dimensions

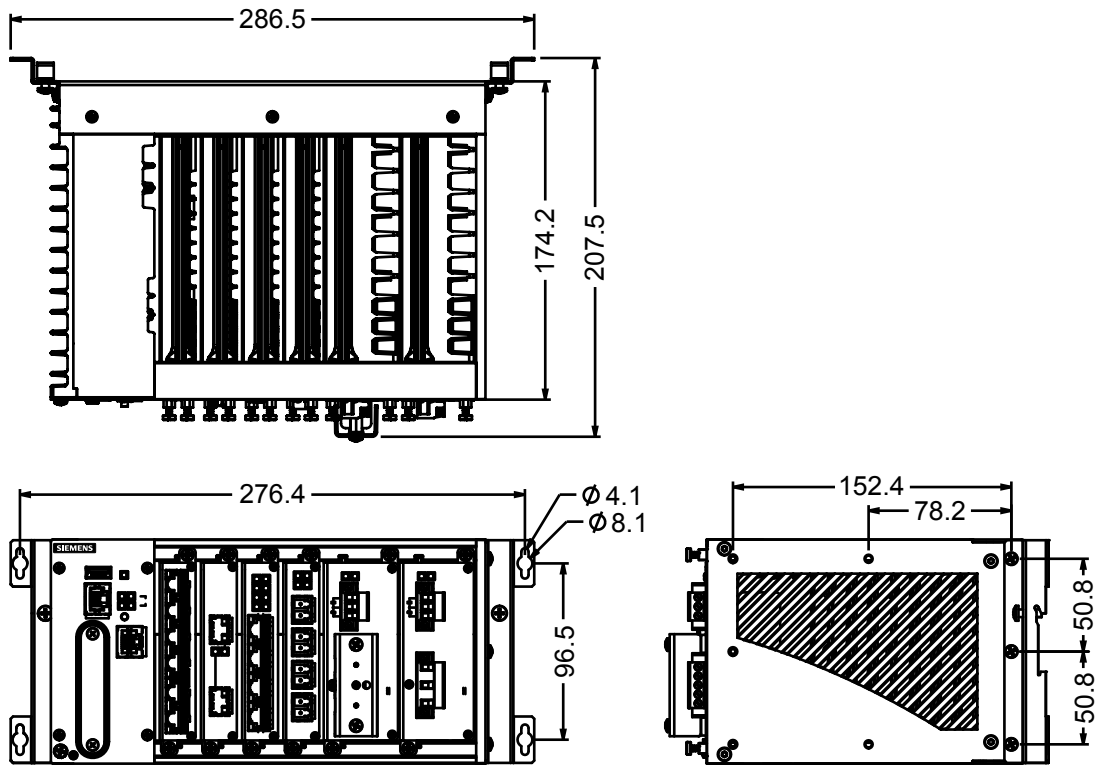

Figure 20: Panel and Din Rail Mount Dimensions

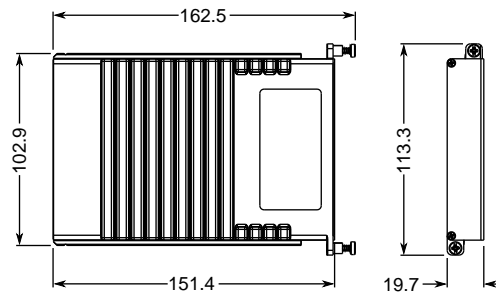

Figure 21: Line Module Dimensions

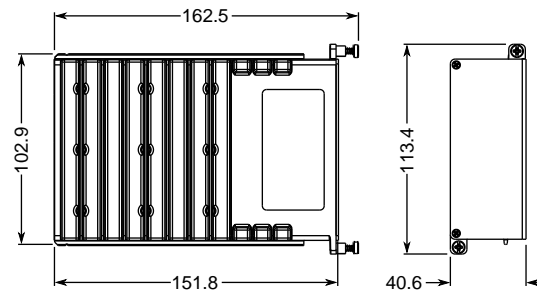

Figure 22: Power Module Dimensions



# 6 Certification

The RUGGEDCOM RX1510 device has been thoroughly tested to guarantee its conformance with recognized standards and has received approval from recognized regulatory agencies.

**NOTE**

*Certifications related to individual modules are detailed in the RUGGEDCOM Modules Catalog for the device available online.*

**CONTENTS**

- [Section 6.1, "Approvals"](#)
- [Section 6.2, "EMC and Environmental Type Tests"](#)

## Section 6.1

## Approvals

This section details the standards to which the RUGGEDCOM RX1510 complies.

**CONTENTS**

- [Section 6.1.1, "TÜV SÜD"](#)
- [Section 6.1.2, "European Union \(EU\)"](#)
- [Section 6.1.3, "FCC"](#)
- [Section 6.1.4, "FDA/CDRH"](#)
- [Section 6.1.5, "ISED"](#)
- [Section 6.1.6, "RoHS"](#)
- [Section 6.1.7, "Other Approvals"](#)

## Section 6.1.1

### TÜV SÜD

This device is certified by TÜV SÜD to meet the requirements of the following standards:

- **CAN/CSA-C22.2 NO. 60950-1-07 (R2012)**  
Information Technology Equipment – Safety – Part 1: General Requirements (Bi-National standard, with UL 60950-1)
- **UL 60950-1**  
Information Technology Equipment – Safety – Part 1: General Requirements)

Section 6.1.2

## European Union (EU)

This device is declared by Siemens Canada Ltd to comply with essential requirements and other relevant provisions of the following EU directives:

- **Directive 2014/30/EU**  
Directive 2014/30/EU of the European Parliament and of the Council of 26 February 2014 on the harmonisation of the laws of the Member States relating to electromagnetic compatibility (recast) Text with EEA relevance
- **Directive 2014/35/EU**  
Directive 2014/35/EU of the European Parliament and of the Council of 26 February 2014 on the harmonisation of the laws of the Member States relating to the making available on the market of electrical equipment designed for use within certain voltage limits Text with EEA relevance
- **Directive 2011/65/EU**  
Directive 2011/65/EU of the European Parliament and of the Council of 8 June 2011 on the restriction of the use of certain hazardous substances in electrical and electronic equipment Text with EEA relevance
- **Directive 1999/5/EC**  
Directive 1999/5/EC of the European Parliament and of the Council of 9 March 1999 on radio equipment and telecommunications terminal equipment and the mutual recognition of their conformity
- **EN 60950-1**  
Information Technology Equipment – Safety – Part 1: General Requirements
- **EN 61000-3-2**  
Electromagnetic compatibility (EMC) – Part 3-2: Limits – Limits for harmonic current emissions (equipment input current  $\leq 16$  A per phase)
- **EN 61000-3-3**  
Electromagnetic compatibility (EMC) – Part 3-3: Limits – Limitation of voltage changes, voltage fluctuations and flicker in public low-voltage supply systems, for equipment with rated current  $\leq 16$  A per phase and not subject to conditional connection
- **EN 61000-6-2**  
Electromagnetic Compatibility (EMC) – Part 6-2: Generic Standards – Immunity for Industrial Environments
- **EN 60825-1**  
Safety of Laser Products – Equipment Classification and Requirements
- **EN 50581**  
Technical Documentation for the Assessment of Electrical and Electronic Products with Respect to the Restriction of Hazardous Substances
- **EN 55022**  
Information Technology Equipment – Radio Disturbance Characteristics – Limits and Methods of Measurement

The device is marked with a CE marking and notified body number, and can be used throughout the European community.

**CE 0680**

A copy of the CE Declaration of Conformity is available from Siemens Canada Ltd. For contact information, refer to [“Contacting Siemens”](#).

Section 6.1.3

## FCC

This device has been tested and found to comply with the limits for a Class A digital device, pursuant to Part 15 of the FCC Rules. These limits are designed to provide reasonable protection against harmful interference when the equipment is operated in a commercial environment.

This device generates, uses and can radiate radio frequency energy and, if not installed and used in accordance with the instruction manual, may cause harmful interference to radio communications. Operation of this equipment in a residential area is likely to cause harmful interference in which case users will be required to correct the interference at their own expense.



**IMPORTANT!**

*Changes or modifications not expressly approved by the party responsible for compliance could void the user's authority to operate this device.*

Section 6.1.4

## FDA/CDRH

This device meets the requirements of the following U.S. Food and Drug Administration (FDA) standard:

- Title 21 Code of Federal Regulations (CFR) – Chapter I – Sub-chapter J – Radiological Health

Section 6.1.5

## ISED

This device is declared by Siemens Canada Ltd to meet the requirements of the following ISED (Innovation Science and Economic Development Canada) standard:

- CAN ICES-3 (A)/NMB-3 (A)

Section 6.1.6

## RoHS

This device is declared by Siemens Canada Ltd to meet the requirements of the following RoHS (Restriction of Hazardous Substances) directives for the restricted use of certain hazardous substances in electrical and electronic equipment:

- **China RoHS 2**  
Administrative Measure on the Control of Pollution Caused by Electronic Information Products

A copy of the Material Declaration is available online at <https://support.industry.siemens.com/cs/ww/en/view/109738831>.

## Section 6.1.7

## Other Approvals

This device meets the requirements of the following additional standards:

- **IEEE 1613**  
IEEE Standard Environmental and Testing Requirements for Communications Networking Devices in Electric Power Substations
- **IEC 61000-6-2**  
Electromagnetic Compatibility (EMC) – Part 6-2: Generic Standards – Immunity for Industrial Environments
- **IEC 61850-3**  
Communication Networks and Systems in Substations – Part 3: General Requirements

## Section 6.2

## EMC and Environmental Type Tests

The RUGGEDCOM RX1510 has passed the following Electromagnetic Compatibility (EMC) and environmental tests.

### » EMC Type Test for IEC 61850-3

Test	Description		Test Levels	Severity Levels
IEC 61000-4-2	ESD	Enclosure Contact	$\pm 8$ kV	4
		Enclosure Air	$\pm 15$ kV	
IEC 61000-4-3	Radiated RFI	Enclosure Ports	20 V/m	Note <sup>a</sup>
IEC 61000-4-4	Burst (Fast Transient)	Signal ports	$\pm 4$ kV @ 2.5 kHz	4
		DC Power Ports	$\pm 4$ kV	
		AC Power Ports		
		Earth ground ports		
IEC 61000-4-5	Surge	Signal ports	$\pm 4$ kV Line-to-Ground $\pm 2$ kV Line-to-Line	4
		DC Power Ports	$\pm 2$ kV Line-to-Ground $\pm 1$ kV Line-to-Line	3
		AC Power Ports	$\pm 4$ kV Line-to-Ground $\pm 2$ kV Line-to-Line	4
IEC 61000-4-6	Induced (Conducted) RFI	Signal ports	10 V	3
		DC Power Ports		
		AC Power Ports		
		Earth ground ports		
IEC 61000-4-8	Magnetic Field	Enclosure Ports	100 A/m, continuous 1000 A/m for 1 s	Note <sup>a</sup>

Test	Description		Test Levels	Severity Levels
			1000 A/m for 1 s	5
IEC 61000-4-11	Voltage Dips and Interrupts	AC Power Ports	30% for 1 period 60% for 50 periods	
IEC 61000-4-12	Damped Oscillatory	Signal ports	2.5 kV common, 1 kV differential mode @1 MHz	3
		DC Power Ports		
		AC Power Ports		
IEC 61000-4-16	Mains Frequency Voltage	Signal ports	30 V Continuous 300 V for 1 s	4
		DC Power Ports		
IEC 61000-4-17	Ripple on DC Power Supply	DC Power Ports	10%	3
IEC 61000-4-29	Voltage Dips and Interrupts	DC Power Ports	30% for 0.1 s 60% for 0.1 s 100% for 0.05 s	
IEC 60255-5	Dielectric Strength	Signal ports	2 kV (Failsafe Relay output)	
		DC Power Ports	1.5 kV	
		AC Power Ports	2 kV	
	HV Impulse	Signal ports	5 kV (Failsafe Relay output)	
		DC Power Ports	5 kV	
		AC Power Ports		

<sup>a</sup> Siemens-specified severity levels

## » EMC Immunity Type Tests for IEEE 1613



### NOTE

The RUGGEDCOM RX1510 meets Class 2 requirements for an all-fiber configuration and Class 1 requirements for copper ports. Class 1 allows for temporary communication loss, while Class 2 requires error-free and interrupted communications.

Description		Test Levels
HV Impulse	Signal ports	5 kV (Failsafe Relay Output)
	DC Power Ports	5 kV
	AC Power Ports	
Dielectric Strength	Signal ports	2 kV
	DC Power Ports	1.5 kV
	AC Power Ports	2 kV
Fast Transient	Signal ports	± 4 kV @ 2.5 kHz
	DC Power Ports	± 4 kV
	AC Power Ports	

Description		Test Levels
Oscillatory	Earth ground ports	
	Signal ports	2.5 kV common mode @1MHz
	DC Power Ports	2.5 kV common
	AC Power Ports	1 kV differential mode @ 1 MHz
Radiated RFI	Enclosure ports	35 V/m
ESD	Enclosure Contact	± 8 kV
	Enclosure Air	± 15 kV

## » Environmental Type Tests

Test	Description		Test Levels	Severity Levels
IEC 60068-2-1	Cold Temperature	Test Ad	-40 °C (-40 °F), 16 Hours	
IEC 60068-2-2	Dry Heat	Test Bd	85 °C (185 °F), 16 Hours	
IEC 60068-2-30	Humidity (Damp Heat, Cyclic)	Test Db	95% (non-condensing), 55 °C (131 °F), 6 cycles	
IEC 60255-21-1	Vibration		2 g @ 10-150 Hz	Class 2
IEC 60255-21-2	Shock		30 g @ 11 ms	Class 2
	Bump		10 g @ 16 ms	Class 1
IEC 61373	Long Life (Random Vibration)		Category 1 Class B	
	Shock			
IEC 60255-21-3	Seismic		Method A	Level 2
MIL-STD-810G	Altitude		12192 m (40000 ft) @ 40 °C, 90 minutes	