



PHILIPS

bodine

Emergency Lighting

Product Catalog

Solutions

Life safety emergency lighting

Innovative solutions for emergency lighting applications

Contents

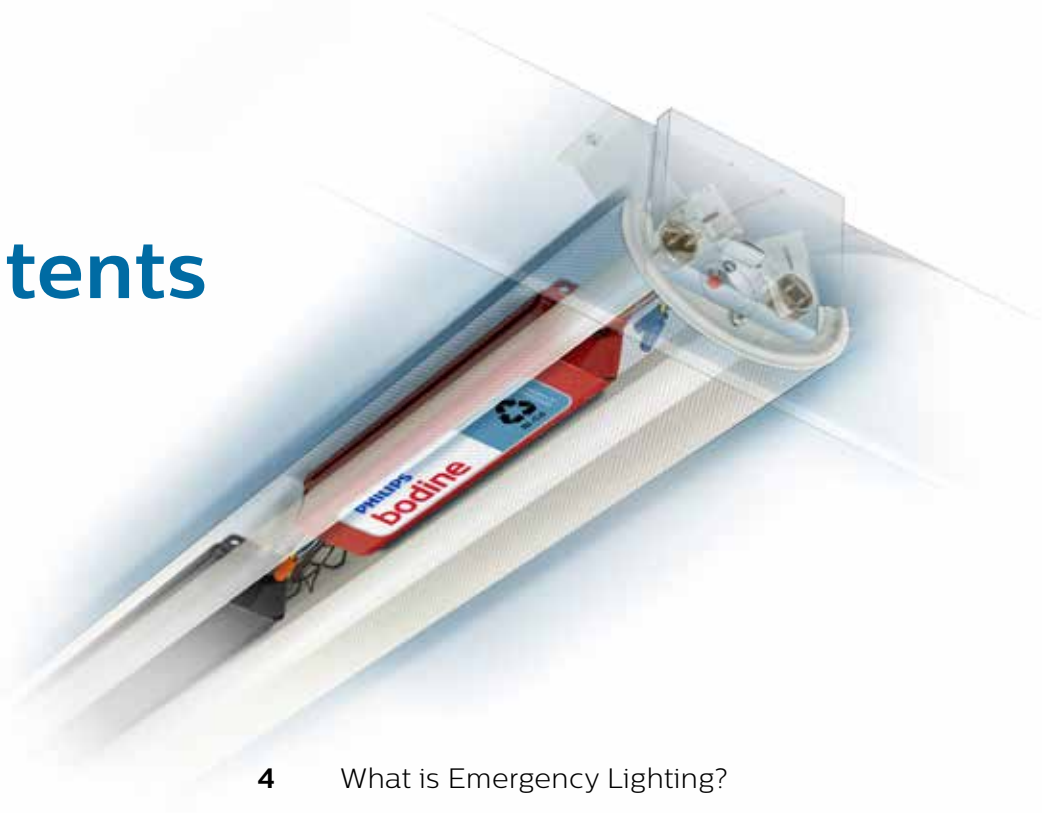

4	What is Emergency Lighting?
6	Emergency Lighting System Design
8	Emergency Code
10	Code-Required Testing
12	Emergency LED Drivers
14	Linear Fluorescent
16	Low-Profile Fluorescent
18	Compact Fluorescent
20	Self-Testing Fluorescent
22	Cold-Pak Fluorescent
24	Generator Products
26	Inverters
30	Special Applications
32	Fluorescent Emergency Ballasts Product Summary
34	LED Product Summary & Selection Guide

What is emergency lighting?

Emergency lighting is a vital part of every facility's life safety program. Local, state and national building codes, such as the NFPA® Life Safety Code® and National Electrical Code®, require reliable and sufficient emergency illumination for commercial, industrial and institutional buildings in the United States. When normal power fails for any reason, emergency lighting provides critical illumination. It helps to guide building occupants along the path of egress to the nearest exit.

Philips Bodine Emergency Lighting Provides Instant Backup

Philips Bodine emergency lighting products provide instant backup lighting whenever normal power fails. Philips Bodine fluorescent emergency ballasts, emergency LED drivers and emergency lighting inverters deliver 90 minutes of battery-supplied power.

Complements Original Designs

Philips Bodine emergency lighting products complement original lighting designs. Because they can be installed inconspicuously inside, on top of, near or remote from the fixture – depending on factors such as fixture, emergency lighting product and product model – they do not detract from fixture or interior design. Philips Bodine emergency lighting is emergency lighting you'll never see until you need it.



Philips Bodine fluorescent emergency ballasts, emergency LED drivers and emergency lighting inverters deliver 90 minutes of battery-supplied power.



When normal power fails, Philips Bodine emergency lighting products sense the loss and immediately switch into emergency mode.



In field applications, a qualified electrician can typically install our products in less than 30 minutes.



Looks Like Normal Lighting

Philips Bodine emergency lighting products use the same light source for normal and emergency lighting. As a result, emergency lighting appears similar to lighting under normal conditions. No drastic change in lighting or unwanted glare occurs.

Reduces the Risk of Tampering

Philips Bodine emergency lighting products may be installed inside, on top of, near or remote from the fixture – depending on factors such as fixture, emergency lighting product and product model. This inconspicuous positioning reduces the risk of tampering and vandalism.

Saves Time and Reduces Labor Costs

Philips Bodine emergency lighting products are factory or field installed.* In field applications, a qualified electrician can typically install our products in less than 30 minutes.

* Some Philips Bodine emergency lighting products, including our emergency LED drivers, are suitable for factory installation only.

Application

Philips Emergency Lighting provides Philips Bodine emergency lighting products for a wide variety of applications, including fluorescent, LED, HID and incandescent. Products are available for indoor, damp and hazardous locations, as well for longer runtimes and for special voltages and line frequencies.

Operation

When normal power fails, Philips Bodine emergency lighting products sense the loss and immediately switch into emergency mode. For many of our product lines, including Philips Bodine fluorescent emergency ballasts, emergency LED drivers and inverters, this means the emergency lighting unit immediately begins supplying supplemental power to support emergency lighting operation for a minimum of 90 minutes. When normal power is restored, the Philips Bodine emergency lighting unit returns to the charging mode.

UL Testing

Philips Bodine emergency lighting products are tested by Underwriters' Laboratories (UL) in accordance with standards set forth in UL 924, "Emergency Lighting and Power Equipment." Products are UL Listed for factory or field installation or Component Recognized for factory installation only.

Philips Emergency Lighting also offers Philips Bodine emergency lighting products that are CSA Certified for Canada and NOM Certified for Mexico.

Emergency Lighting System Design

Codes and regulations establish guidelines for emergency lighting equipment. However, there may be circumstances that call for more than minimum standards. Incorporating the right combination of elements into emergency lighting design provides a higher degree of safety.

The best emergency lighting system is carefully planned for a specific building and its occupants. As a part of this planning process, it is important to consider a variety of factors.

Proximity, Shape and Size of Exits

The configuration of walls adjoining the exit way, the amount of space devoted to exit passages and travel distance to exits should be considered when determining the number and placement of emergency lighting units. For example, it is important to place emergency lighting at an intersection of a corridor or hallway. If it is a large area, additional units may be needed to provide adequate light to see any objects blocking the exit path. Emergency lighting should be evenly spaced.

Number of Persons Expected to Occupy a Building

The number of people expected to occupy a building and their knowledge of its interior also influence the level of emergency illumination needed. Large numbers of people unfamiliar with exit paths require more emergency lighting than smaller numbers of people who know the surroundings. Consequently, auditoriums, convention halls and sports arenas often need higher levels of emergency illumination than factories, office buildings and warehouses.

Color and Texture of Ceiling, Floor and Wall Coverings

Emergency lighting levels are affected by the color and texture of surrounding areas. Light-colored walls and floors with smooth surfaces require less emergency lighting because of their reflective characteristics than do darker floors and walls with rough surfaces.

Intended Use of a Building

Additional emergency lighting may be required depending on the types of people using a facility. Elementary school children, the elderly and the physically challenged, for example, may need more emergency lighting than do apartment residents, college students and factory or office workers. High security facilities and retail situations where valuable merchandise is accessible may require extra illumination. Adequate lighting can be especially critical in hospital settings such as operating and emergency rooms.

The best emergency lighting system is carefully planned for a specific building and its occupants.



Whether your design requires unit equipment or devices for use in conjunction with generators or central inverter systems, Philips Bodine offers the emergency lighting solution for you.

As a part of the planning process, it is important to consider a variety of factors.

Emergency Code

AC power failures occur for a variety of reasons. Storms, tornadoes, hurricanes and other extreme weather conditions can affect AC power. Vehicular accidents, fires or equipment failure can also result in power outages. When this happens, liability concerns are inevitable. Serious accidents or mishaps could occur when occupants are left in total darkness during a power failure. In such instances, the first area of inquiry is often, “Did this building meet code?”

Laws, Codes and Regulations

Although state and local building codes vary, most are based upon:

1. National Electrical Code®, NFPA 70®, Article 700;
2. Life Safety Code®, NFPA 101®, Section 7.9;
3. Occupational Safety and Health Act (OSHA) regulations.

These codes provide complete information about emergency lighting requirements. However, a basic starting point is provided in the LSC 7.9.2.1 (2012), which states:

Specifiers, building owners or facility management may choose to go beyond minimums in their effort to keep people and property safe.

Emergency illumination shall be provided for a minimum of 1½ hours in the event of failure of normal lighting. Emergency lighting facilities shall be arranged to provide initial illumination that is not less than an average of 1 ft-candle (10.8 lux) and, at any point, not less than 0.1 ft-candle (1.1 lux), measured along the path of egress at floor level. Illumination levels shall be permitted to decline to not less than an average of 0.6 ft-candle (6.5 lux) and, at any point, not less than 0.06 ft-candle (0.65 lux) at the end of 1½ hours. A maximum-to-minimum illumination uniformity ratio of 40 to 1 shall not be exceeded.

It is important to remember that codes generally set minimum standards. Specifiers, building owners, facility management or municipalities may choose to go beyond minimums in their effort to keep people and property safe.

Maintenance

Codes mandate periodic monitoring of emergency lighting equipment once it is installed. Emergency operation must be tested at 30-day intervals for a minimum of 30 seconds, and, for battery-powered systems, a 90-minute discharge test must be conducted once a year. Additionally, the NFPA requires that records be kept as proof of maintenance.



Serious accidents or mishaps could occur when occupants are left in total darkness during a power failure. In such instances, the first area of inquiry is often:

“Did this building meet code?”



Functional testing shall be conducted monthly, with a minimum of 3 weeks and a maximum of 5 weeks between tests, for not less than 30 seconds, except as otherwise permitted by 7.9.3.1.1(2).



(7.9.3.1.1(1), NFPA® Life Safety Code® 2012)

Code-Required Testing

7.9.3 Periodic Testing of Emergency Lighting Equipment.

7.9.3.1.1 Testing of required emergency lighting systems shall be permitted to be conducted as follows:

- (1) Functional testing shall be conducted monthly, with a minimum of 3 weeks and a maximum of 5 weeks between tests, for not less than 30 seconds, except as otherwise permitted by 7.9.3.1.1(2).
- (2) The test interval shall be permitted to be extended beyond 30 days with the approval of the authority having jurisdiction.
- (3) Functional testing shall be conducted annually for a minimum of 1½ hours if the emergency lighting system is battery powered.
- (4) The emergency lighting equipment shall be fully operational for the duration of the tests required by 7.9.3.1.1(1) and (3).
- (5) Written records of visual inspections and tests shall be kept by the owner for inspection by the authority having jurisdiction.

7.9.3.1.2 Testing of required emergency lighting systems shall be permitted to be conducted as follows:

- (1) Self-testing/self-diagnostic battery-operated emergency lighting equipment shall be provided.
- (2) Not less than once every 30 days, self-testing/self-diagnostic battery-operated emergency lighting equipment shall automatically perform a test with a duration of a minimum of 30 seconds and a diagnostic routine.
- (3) Self-testing/self-diagnostic battery-operated emergency lighting equipment shall indicate failures by a status indicator.
- (4) A visual inspection shall be performed at intervals not exceeding 30 days.
- (5) Functional testing shall be conducted annually for a minimum of 1½ hours.
- (6) Self-testing/self-diagnostic battery-operated emergency lighting equipment shall be fully operational for the duration of the 1½ hour test.
- (7) Written records of visual inspections and tests shall be kept by the owner for inspection by the authority having jurisdiction.

(NFPA® Life Safety Code® 2012)

Emergency LED Drivers

for Factory Installation Only

The Philips Bodine emergency LED driver line allows LED fixtures to serve as code-compliant emergency lighting sources. The expanding line includes drivers designed for a variety of applications: indoor, outdoor, damp, cold temperatures, steplights, downlights, security lighting, Class 2 installations and more.

As with other types of lighting, LED lighting must meet life safety code requirements for emergency lighting when it is used in an emergency capacity. Therefore, LED fixtures serving as emergency lighting sources must provide 90 minutes of illumination in the event of a power failure.

LED lighting is a rapidly growing segment of the lighting industry. Its popularity is not a mystery. LED technology is continually improving. LEDs offer long life and high efficiency, have low operating costs and are lead and mercury free.

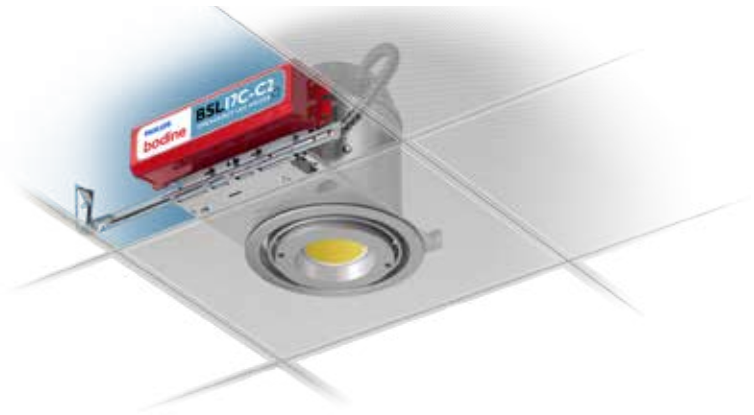

Philips Bodine emergency LED drivers answer the call for emergency lighting in LED applications.

Emergency LED drivers operate very much like fluorescent emergency ballasts. When normal AC power fails, the emergency LED drivers switch into emergency mode and support LED fixtures for 90 minutes. When AC power is restored, the drivers automatically return to the charging mode.



Note: Emergency LED drivers are UL Recognized and must be factory installed with one exception. The BSL310 may be field installed when paired with the Philips EvoKit LED retrofit.



When normal AC power fails, the emergency LED drivers switch into emergency mode and support LED fixtures for 90 minutes.

The products contained in this section are UL Component Recognized for factory installation only. These products may not be purchased by manufacturers' representatives or by distributors.

EXCEPTION: The **BSL310** is field installable exclusively with the Philips Evokit LED retrofit.

Controlled output indicates that the power is being determined electronically by a built-in micro processor.

Emergency LED Driver

Product Summary



Model	Maximum Output Power	Flexible Output Voltage
BSL10 Cold-Pak⁺	10.0 W* controlled output	24 - 52 VDC
BSL17C	7.0 W* controlled output	30 - 80 VDC
BSL17C-C2^o	7.0 W* controlled output	15 - 50 VDC
BSL17C-C2ST	7.0 W* controlled output	15 - 50 VDC
BSL20LV⁺	20.0 W* controlled output	20 - 50 VDC
BSL20MV	20.0 W* controlled output	50 - 130 VDC
BSL20HV	20.0 W* controlled output	125 - 200 VDC
BSL23C	4.5 W	3 - 20 VDC
BSL26C	5.1 W*	3 - 30 VDC
BSL36LP	6.0 W* controlled output	15 - 52 VDC
BSL310^{+o}	10.0 W*	10 - 50 VDC
BSL310CP[#]	10.0 W*	10 - 50 VDC
BSL310LP	10.0 W* controlled output	15 - 52 VDC
BSL310LPST	10.0 W* controlled output	15 - 52 VDC
BSL310HAZ	10.0 W*	10 - 50 VDC
BSL310SB	10.0 W*	10 - 50 VDC
BSL722	23.1 W	28 - 33 VDC
BSL722 Cold-Pak	23.1 W	28 - 33 VDC

* Measured at nominal battery voltage.

⁺ Output Class 2 compliant.

^o Multiple case/conduit options available.

[#] Compatible with CREE LMH LED models.

Linear

Fluorescent Emergency Ballasts

Philips Bodine linear fluorescent emergency ballasts (FEBs) are designed specifically for linear lamp fluorescent fixtures. These emergency ballasts allow you to convert virtually any new or existing fluorescent fixture into code-compliant emergency lighting.

One-lamp, two-lamp, even four-lamp fixtures with T5, T8, T10 or T12 lamps can be converted with a Philips Bodine linear FEB. Using the same light source for both normal and emergency lighting allows emergency lighting to look similar to normal lighting and saves time, labor and materials. In addition, the FEBs' unobtrusive installation does not detract from interior design. Philips Bodine FEBs provide emergency lighting you'll never see ... until you need it.



Emergency lighting is vital to life safety programs and is required in all commercial, industrial and institutional facilities.

What is a Fluorescent Emergency Ballast?

A FEB is a battery-powered device that, in the absence of normal AC power, supports one or more fluorescent lamps, providing a minimum 90 minutes of emergency lighting. Emergency lighting is vital to life safety programs and is required in all commercial, industrial and institutional facilities. When normal power fails, emergency lighting guides building occupants along the path of egress to designated exits and helps them avoid obstacles along the way.

“When normal power fails, emergency lighting guides building occupants along the path of egress to designated exits and helps them avoid obstacles along the way.”



“ Philips Bodine linear FEBs provide emergency lighting you’ll never see ... **until you need it.**”

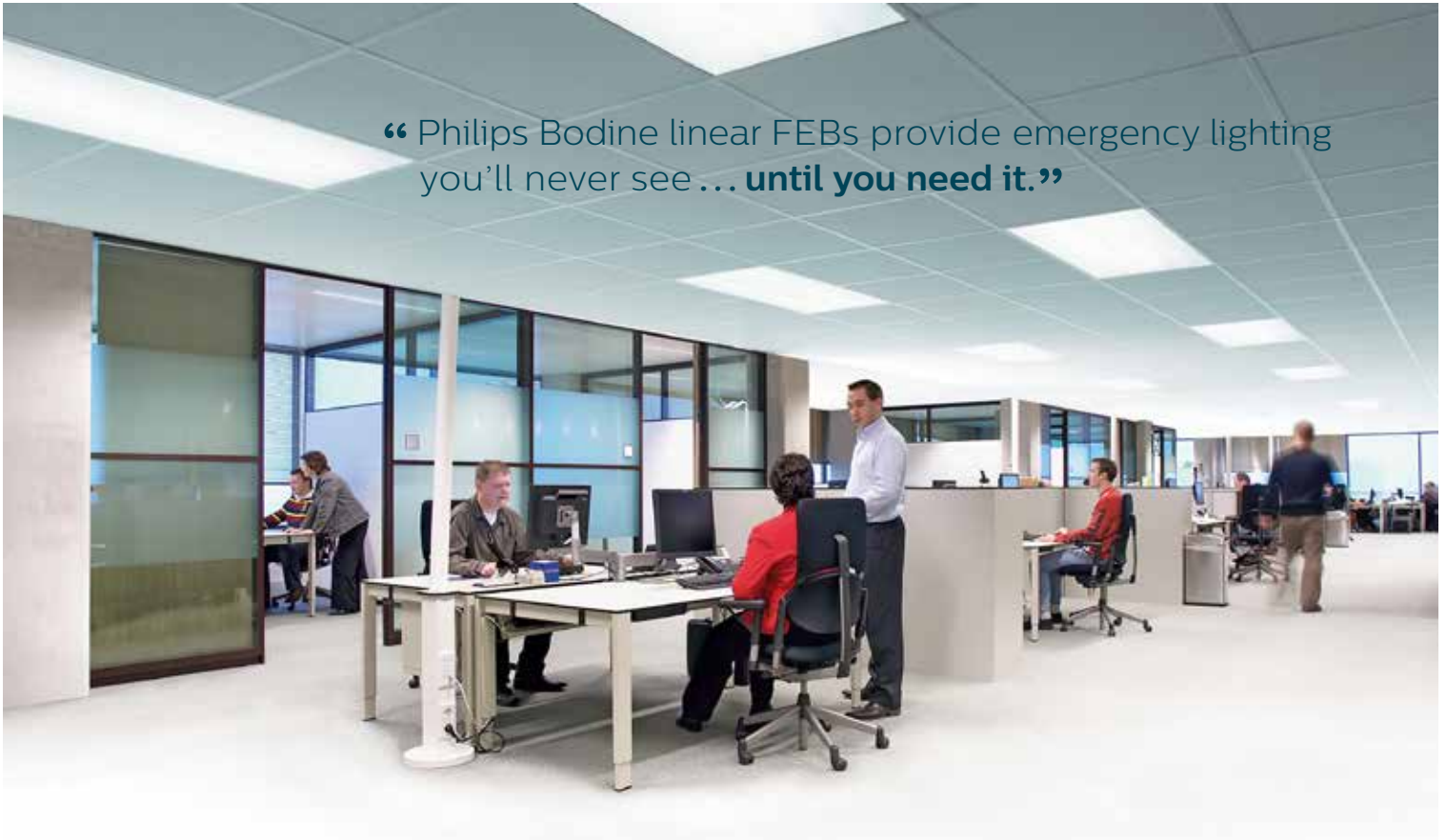

Model	Type of Lamps Operated	Max. Lumens*	Feature
B30	(2'-8') T5s, T8s, T9s, T10s or T12s	3500	High lumen output except T5s; AC/DC output **
B30HV	(2'-8') T5s, T8s, T9s, T10s or T12s	3500	Optimal choice for T5HO high bay; 347/480 volts
B30ST	(2'-8') T5s, T8s, T9s, T10s or T12s	3500	Automatic self-testing; high lumen output; AC/DC output **
B33	32 W (4') T8s	3400	Optimized for two- or three-lamp operation
B50	(2'-8') T5s, T8s, T9s, T10s or T12s	1400	Spec grade; Universal input; Low-profile; AC/DC output
B50 Cold-Pak	(2'-8') T8s, T9s, T10s or T12s	1200	Extreme temperatures
B50ST	(2'-8') T8s, T9s, T10s or T12s	1400	Automatic self-testing; Universal input
B54	(2'-4') T8s, T10s or T12s	450	Four-hour emergency illumination; Universal input
B60	(2'-8') T8s, T9s, T10s or T12s	700	Standard grade
B70A	(2'-8') T8s, T10s or T12s	700	Extended runtime
B90	(2'-8') T8s, T10s or T12s	600	Economical alternative
B100	(2'-4') T8s, T10s or T12s	450	Minimum code-compliance

* Refer to specific model specification sheets for lumen output by lamp type.

** Available on upgraded units Q3 2015.

Low-Profile

Fluorescent Emergency Ballasts

Philips Bodine low-profile fluorescent emergency ballasts permit ballast channel installation into space-limited fixtures.

Technological advancements in fluorescent lamps and electronic ballasts have led to a proliferation of innovative, space-saving fluorescent fixture designs. Philips Bodine low-profile FEBs accommodate these designs. The FEBs' slim dimensions are ideal for pendant, cove, recessed indirect/direct, surface-mount, low-profile linear and other such fixtures.

The Philips Bodine low-profile FEBs provide form as well as function while accommodating innovative, space-saving fluorescent fixture designs.

The low-profile emergency ballasts operate standard and high-output T5 and T8 lamps and are compatible with electronic, standard, energy-saving and dimming AC ballasts. Their inconspicuous installation not only preserves fixture/room design, it may also reduce the likelihood that the emergency ballast will be noticed by would-be vandals. With Philips Bodine low-profile units, users don't have to choose; they can have form and function.



Model	Type of Lamps Operated	Max. Lumens*	Feature
B50LP	One- or two-lamp operation for 17-215 W (2'-8') T8s, T9s, T10s & T12s	1300	Damp locations; Sealed/gasketed fixtures
B60LP	One- or two-lamp operation for 17-215 W (2'-8') T8s, T9s, T10s & T12s	700	Damp locations; Sealed/gasketed fixtures
LP500	One-lamp operation for 21-54 W standard or high output T5 or 32 W T8	700	Low-mercury lamps; Sealed/gasketed fixtures
LP550	One-lamp operation for standard and high output T5s & T8s; (4-pin) long compacts	700	Low-mercury lamps; Sealed/gasketed fixtures
LP600	One-lamp operation for standard and high output T5s & T8s; (4-pin) long compacts	1325	Low-mercury lamps; Sealed/gasketed fixtures
LP600STU	One-lamp operation for standard and high output T5s & T8s; (4-pin) long compacts	1325	Automatic self-test; Universal input; Low-mercury lamps

* Refer to specific model specification sheets for lumen output by lamp type.



Recommended uses include office buildings, retail outlets, hospitality spaces, healthcare facilities and any other location where aesthetics is a concern.

The low-profile emergency ballasts allow users to meet code without sacrificing room or fixture aesthetics.



Compact

Fluorescent Emergency Ballasts

Philips Bodine compact fluorescent emergency ballasts (FEBs) are designed specifically for compact lamp fluorescent fixtures.

They allow you to easily convert new or existing fluorescent fixtures into code-compliant emergency lighting. Philips Bodine compact FEBs operate most 4-pin compact fluorescent lamps, including twin-tube, double twin-tube (quad), triple twin-tube, long compact and 2D. Because the same light source is used for normal and emergency lighting, emergency lighting looks similar to normal lighting – no drastic lighting change or unwanted glare results. In addition, the FEBs' unobtrusive installation does not detract from interior design or encourage vandal activity.

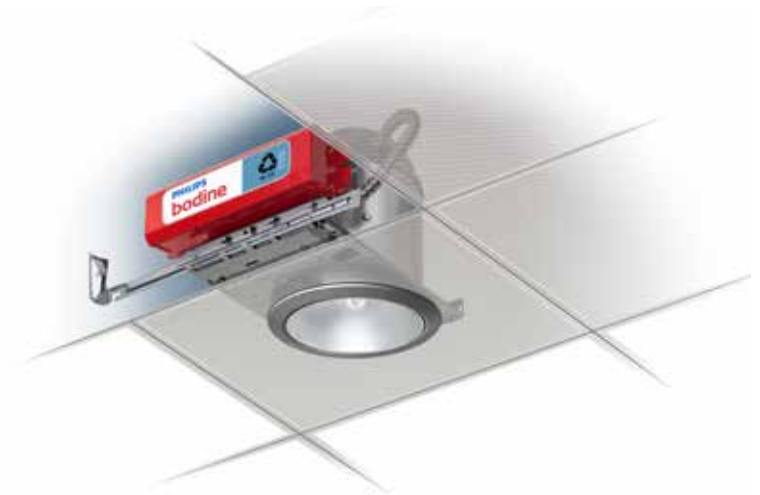

Philips Bodine compact (FEBs) allow you to easily convert new or existing fluorescent fixtures into code-compliant emergency lighting.

FEB vs. AC Ballast

Fluorescent lamps require AC ballasts for startup and for current regulation during normal operation. When AC power fails and normal lamp operation ceases, the Philips Bodine battery-powered FEBs are critical. FEBs supply power to the lamp(s) and allow the lamp(s) to provide full or reduced illumination for a minimum of 90 minutes in compliance with national safety codes for emergency lighting (e.g., NFPA® Life Safety Code® and National Electrical Code®).

Extreme Temp Compacts

The B4CF2P/B4CF2PC family features one- or two-lamp parallel operation. These fluorescent emergency ballasts are available in conduit and non-conduit models and in Cold-Pak and non-Cold-Pak models. The B4CF2P Cold-Pak and B4CF2PC Cold-Pak operate in an extended temperature range of -4° F to +122° F (-20° C to +50° C).





“ Because the same light source is used for normal and emergency lighting, emergency lighting looks similar to normal lighting – no drastic lighting change or unwanted glare results. ”



Model	Type of Lamps Operated	Max. Lumens*	Feature
B30HV	One 18-42 W compact fluorescent lamp; (2'-8") T5s, T8s, T9s, T10s or T12s	3500	High voltage applications
B75C	(4-pin) triple twin-tubes	1300	Low-mercury (green) lamps
B84CG	(4-pin) twins, quads or triple twin-tubes; T5 circlines; (4-pin) long compacts	1250	Low-mercury (green) lamps
B94CGU	(4-pin) twins, quads or triple twin-tubes	750	Low-mercury (green) lamps; Universal input
B94GU	(4-pin) twins, quads or triple twin-tubes	750	Low-mercury (green) lamps; Universal input
B4CF1 Cold-Pak	(4-pin) twins, quads or triple twin-tubes; T5 circlines; (4-pin) long compacts	1250	Extreme temperatures
B4CF2 Cold-Pak	(4-pin) twins, quads or triple twin-tubes; T5 circlines; (4-pin) long compacts	1250	Extreme temperatures
B4CF2P** Cold-Pak	(4-pin) twins, quads or triple twin-tubes; T5 circlines; (4-pin) long compacts	925	Parallel operation
B4CF2PC** Cold-Pak	(4-pin) twins, quads or triple twin-tubes; T5 circlines; (4-pin) long compacts	925	Parallel operation with conduit
B4CF3 Cold-Pak	(4-pin) twins, quads or triple twin-tubes; T5 circlines; (4-pin) long compacts	1250	Extreme temperatures
B4CFG	(4-pin) twins, quads or triple twin-tubes; T5 circlines; (4-pin) long compacts	1250	Low-mercury (green) lamps

* Refer to specific model specification sheets for lumen output by lamp type.

** B4CF2P and B4CF2PC models are also available in non-Cold-Pak versions.

Self-Testing

Fluorescent Emergency Ballasts

Philips Bodine self-testing/self-diagnostic fluorescent emergency ballasts automatically test emergency lighting operation for 30 seconds every 30 days and for 90 minutes annually, in accordance with life safety codes. In addition, they continuously self-monitor their charging current and battery voltage. A flashing LED indicator light alerts maintenance personnel to fault conditions.

The self-test emergency ballasts reduce the labor, time and cost involved in code-compliant testing. They also help ensure testing is done as required. Self-testing units are ideal for hard-to-reach fixtures and fixtures in high-traffic locations, and they simplify the task of testing large numbers of fixtures. Self-testing fluorescent emergency ballasts are the automatic solution for meeting code requirements.



A flashing LED indicator light alerts maintenance personnel to fault conditions.

Philips Bodine self-testing/self-diagnostic fluorescent emergency ballasts automatically test emergency lighting operation for 30 seconds every 30 days and for 90 minutes annually.



The self-test fluorescent emergency ballasts are the automatic solution for meeting code requirements.



The self-test units are ideal for schools, institutional facilities, public buildings, healthcare environments, industrial plants and any other location with difficult-to-test fixtures. Difficulty may be due to locations, traffic patterns or the number of fixtures to be tested.



Model	Type of Lamps Operated	Max. Lumens*	Feature
B30ST	One- or two-lamp operation for most 17-215 W (2'-8') T5s-T12s	3500	High-lumen output except T5s
B50ST	One- or two-lamp operation for most 17-215 W (2'-8') T8s-T12s	1400	Specification grade; Universal input
LP600STU	One-lamp operation for standard and HO T5s and T8s, TLeds	1325	Low-profile; Universal input

* Refer to specific model specification sheets for lumen output by lamp type.

Cold-Pak

Cold-Temperature FEBs

Cold-Paks are designed to withstand temperatures ranging from -4° F to +131° F (-20° C to +55° C) and are suitable for use in indoor and damp locations.



The Philips Bodine Cold-Pak extended-temperature fluorescent emergency ballast line provides code-compliant emergency lighting under challenging conditions. Cold-Paks are designed to withstand temperatures ranging from -4° F to +131° F (-20° C to +55° C) and are suitable for use in indoor and damp locations. Non-conduit Cold-Paks may also be used in sealed & gasketed fixtures. The Cold-Pak line includes models for linear and compact lamps.

Cold-Paks are ideal for a variety of applications, including wall sconces, downlights, bollards, cold storage areas, parking garages and canopied outdoor walkways. They are a great option for outdoor egress. Like our other FEBs, Cold-Paks provide a minimum 90 minutes of emergency lighting.

Recommended uses for the Cold-Pak include cold storage facilities, exterior stairways, food processing plants, outdoor canopies and parking garages. **B4CF1 Cold-Pak, B4CF2 Cold-Pak, B4CF2P Cold-Pak, B4CF2PC Cold-Pak and B4CF3 Cold-Pak** are ideal for bollards, downlights and sconces.





How low does your emergency ballast go? Philips Bodine Cold-Pak emergency ballasts provide reliable, code-compliant emergency lighting in environments with temperatures as extreme as -4° F / -20° C.



Model	Type of Lamps Operated	Max. Lumens*	Feature
B50 Cold-Pak	(2'-8') T8s, T9s, T10s or T12s	1200	For linear lamp fixtures
B4CF1 Cold-Pak	(4-pin) twins, quads or triple twin-tubes; T5 circline; long compacts	1250	For compact fixtures
B4CF2 Cold-Pak	(4-pin) twins, quads or triple twin-tubes; T5 circline; long compacts	1250	For compact fixtures; Conduit for remote mounting
B4CF2P Cold-Pak	(4-pin) twins, quads or triple twin-tubes; T5 circline; long compacts	925	For compact fixtures; One- or two-lamp parallel operation
B4CF2PC Cold-Pak	(4-pin) twins, quads or triple twin-tubes; T5 circline; long compacts	925	For compact fixtures; One- or two-lamp parallel operation; With conduit
B4CF3 Cold-Pak	(4-pin) twins, quads or triple twin-tubes; T5 circline; long compacts	1250	For compact fixtures; Alternate case size

* Refer to specific model specification sheets for lumen output by lamp type.

The B4CF2P Cold-Pak and B4CF2PC Cold-Pak units have a temperature range of -4° F to +122° F (-20° C to +50° C). All other Cold-Pak models are suitable for -4° F to +131° F (-20° C to +55° C).

The BSL10 Cold-Pak is listed in the emergency LED driver table in the LED section of this catalog. It is designed for factory installation only. Please refer to that section for the product specs.

Generator

Products for Generator Applications

Generators are often employed to back up the normal power supply for important systems, such as lighting. Philips Emergency Lighting offers distinct products for generator applications.

Philips Emergency Lighting offers distinct product families created to work with generators:

GTD and **BLCD-20B**.



These energy-saving devices sense the loss of normal power and, in response, switch the lighting load to a generator- or inverter-fed circuit.





GTD/BLCD-20B

The **GTD** and **BLCD-20B** work in conjunction with a generator or central inverter system to supply emergency lighting regardless of local light switch position. This means emergency lighting is no longer dependent on expensive night lighting. In fact, you can switch off normal lighting at the end of the day or whenever it's not needed without jeopardizing emergency lighting operation. These energy-saving devices sense the loss of normal power and, in response, switch the lighting load to a generator- or inverter-fed circuit.



Model	Function	Lighting Load
GTD	Transfer Device	3A max for fluorescent and LED
BLCD-20B	Control or Bypass Device	20A max for fluorescent and LED; 10A max for incandescent

GTD

The **GTD** operates as a transfer device and functions by transferring both the hot and the neutral. It is designed for areas in which only one fixture may be needed for egress lighting, such as a stairwell or classroom, or in areas where multiple switches are in use. The **GTD** supports a lighting load up to 3A.

BLCD-20B

The **BLCD-20B** operates as a control or bypass device. The small (1.7" x 2.97" x 1.64"), easy-to-install unit mounts directly onto a junction box and supports a lighting load up to 20A. The **BLCD-20B** features auto-select to automatically select the correct voltage (120/277V) and offers a remote testing capability that permits it to interface with fire alarms and security panels.

UL 1008

GTD20A

The **GTD20A** Relay Control Device, like the **GTD** and **BLCD-20B**, works with a generator or central inverter system to supply power to designated loads. It functions as a transfer device and may be installed in areas where a number of fixtures are used and are controlled with a single switch. The device senses the loss of normal power service to the fixtures and immediately switches the load to designated alternate circuit. The **GTD20A** allows multiple application and wiring options, including wiring schemes for both line and low voltage dimming. It features universal input and supports a maximum lighting load of 20A.

The **GTD20A** is classified under Optional Standby Systems (NEC® Article 702).



Model	Function	Lighting Load
GTD20A	Transfer Device	20A max for fluorescent, incandescent, HID and LED

Inverters

for Emergency Lighting Applications

Philips Bodine emergency lighting inverters are sinusoidal (sine wave) units that support LED and fluorescent fixtures during loss of normal AC power. The inverters sense the loss and immediately begin supplying emergency power to the designated lighting load. Philips Bodine inverters support emergency lighting for 90 minutes, in accordance with code-established runtime requirements (NFPA® Life Safety Code®).

When an emergency LED driver cannot be used, line voltage inverters, such as ELI-S-20 and ELI-S-100, may be the best solution.

A key feature of Philips Bodine emergency lighting inverters is sinusoidal output. Sinusoidal output is especially important for LED applications and is characterized by low harmonic distortion and by clean power similar to that produced by utility-supplied electricity.

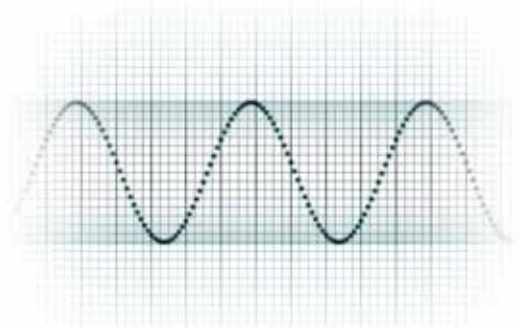

In addition to inverters, Philips Emergency Lighting offers an outstanding line of emergency LED drivers. However, drivers won't work in every situation. For example, when an integral-base lamp is involved, an emergency driver cannot be wired in. In this case, the emergency lighting inverter is your solution.

Philips Bodine emergency lighting inverters are UL Listed.

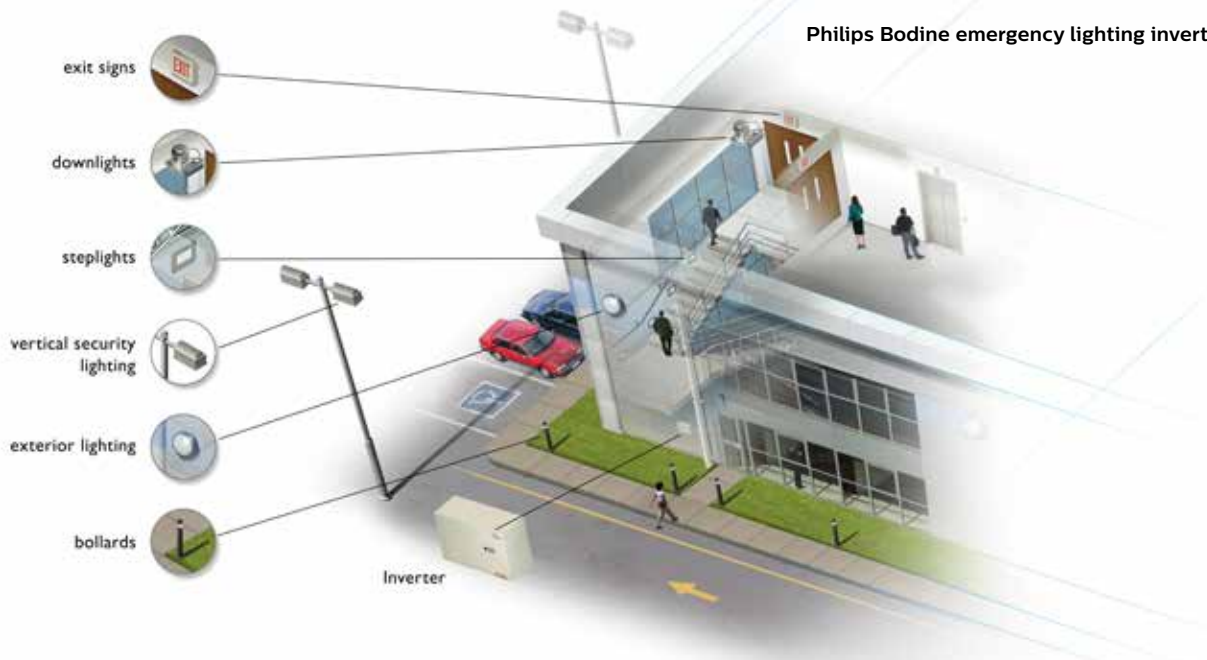

A few of the many applications for Philips Bodine ELI inverter

ELI-S-20

Emergency Lighting Inverter

The Philips Bodine 25W **ELI-S-20** emergency lighting inverter transforms LED and fluorescent fixtures into code-compliant emergency lighting.

It is the ideal emergency backup for the Edison-base (screw-base) LED lamps that are commonly replacing CFLs in retrofit applications and is a superior choice for office, retail, hospitality and other similar spaces.

ELI-S-20 allows fixtures to be on, off, switched or dimmed. It supports 100% of AC rated output throughout its 90-minute runtime so fixtures operate at full brightness during emergency operation. The device provides power to the input side of the fixture, including the ballast, and is designed for use with indoor applications.

The **ELI-S-20** features an LED-friendly sinusoidal (sine) waveform rather than square waveform output. Sinusoidal waveform is characterized by very low harmonic distortion and by clean power similar to that produced by utility-supplied electricity, making the **ELI-S-20** well suited for even the most sensitive LED lighting.

The inverter is UL Listed (25W) and CSA Certified (20W) unit equipment and designed for new and retrofit lighting projects.

ELI-S-20 includes auto select (120/277 VAC) to reduce wiring errors. With the convenient auto select, **ELI-S-20** automatically detects input voltage and sets the output voltage accordingly.



Product Highlights

- Works with LED and fluorescent fixtures up to 25W
- Supplies 90 minutes of emergency illumination at full brightness
- Provides power to the input side of connected lighting loads
- Ideal for but not limited to screw-base LED lamps
- Compatible with Philips 22W TLED linear LED lamps and other manufacturers' LED lamps
- Suitable for indoor, dry and damp applications
- Features fused output load connections
- AC Input Power Rating: 9.5W; output voltage 120/277 VAC (auto select), 60 Hz
- Dimensions: 16.6" x 2.8" x 2.85"
- Remote mounting distance: 250 feet maximum
- Warranty: 5 years (not pro-rata)
- UL Listed for 25W / CSA Certified for 20W



Model	Wattage	Feature
ELI-S-20	25	For LED and fluorescent lamps

UL Listed for Field Installation

ELI-S-100

Sinusoidal Emergency Lighting Inverter

The **ELI-S-100** provides emergency output power of 100W maximum and supports the lighting load for a minimum of 90 minutes. While the **ELI-S-100** works with both fluorescent and LED lighting, it offers two important features for LED applications: dimming capabilities and sinusoidal output.

Dimming in LED Applications

ELI-S-100's dimming feature delivers cost-savings, flexibility and control in LED applications. The dimming capability allows a higher power fixture to operate at a dimmed 100W maximum emergency-mode lighting level, eliminating reliance on a high power inverter to run the fixture. Alternately, **ELI-S-100** allows a string of multiple fixtures to be driven in emergency mode at a combined 100W maximum. For example, four 100W fixtures each dimmed to 20% of normal power may be connected to the ELI-S-100.

Multiple fixture calculation:

$100W \text{ fixture} \times 20\% \text{ dimming} \times 1.2 \text{ (number representing power used by the driver)} = 24W \text{ per fixture}$
 $24W \text{ per fixture} \times 4 \text{ fixtures} = 96W \text{ total}$

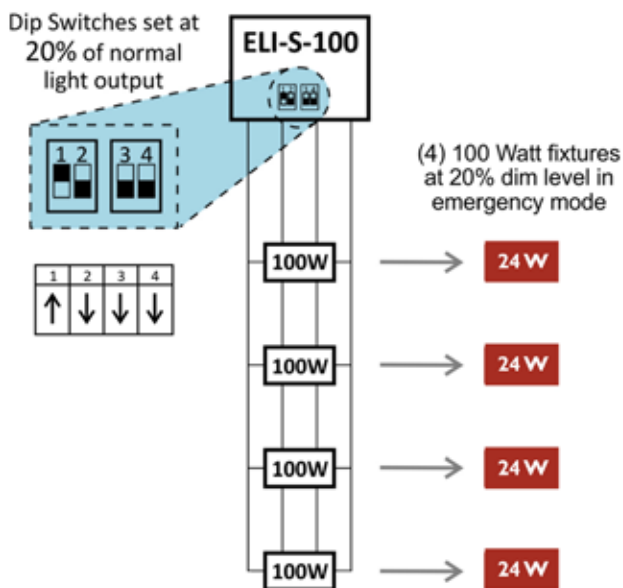

Note dimming drivers are less efficient at reduced power. This inefficiency must be accounted for in the design.



Two models are available:
ELI-S-100-120V and **ELI-S-100-277V**.

Sinusoidal Output

The **ELI-S-100** features an LED-friendly sinusoidal (sine) waveform rather than square waveform output. Sinusoidal waveform is characterized by very low harmonic distortion and by clean power similar to that produced by utility-supplied electricity.

Product Highlights

- Compatible with LED and fluorescent fixtures
- Provides emergency output power of 100W max
- Features sinusoidal output
- Dimming compatible with 0-10V systems
- May be connected to one or multiple fixtures
- Supports emergency lighting for a minimum of 90 minutes
- Includes fused output load connections
- Two versions available: 120V model and 277V model
- Remote mounting distance: 250 ft.
- Temperature rating: 32° F to 104° F (0° C to 40° C)
- Dimensions: 12.562" x 9.812" x 4.675"
(319 mm x 249 mm x 119 mm)
- Weight: 25 lbs. (11.34 kg) with batteries installed
- Warranty: Unit, 5 years; Battery, 3 years +7 years pro-rated
- UL Listed/CSA Certified
- Designed for field installation

The **ELI-S-100** provides a dimming control output of 2-10 volts, and the emergency-mode dimming voltage is field-settable in five steps to provide nominally 20%, 40%, 60%, 80% or 100%. The dimming feature requires a dimming AC driver.

Model	Wattage	Feature
ELI-S-100	100	Offers LED dimming capabilities



ELI-S-250

Sinusoidal Emergency Lighting Inverter

The Philips Bodine **ELI-S-250** emergency lighting inverter provides backup power for LED, fluorescent and incandescent lighting. It supports a maximum load of 250 VA in emergency mode for 90 minutes and features an LED-friendly sinusoidal (sine) waveform output. A sinusoidal waveform is characterized by very low harmonic distortion and by clean power similar to that produced by utility-supplied electricity.

Whenever normal power is lost, the **ELI-S-250** immediately begins supplying emergency power to the connected lighting load. It will support lumen output at 91% of the lamp's rating throughout the 90-minute duration. When normal power is restored, the automatic, temperature-compensated, variable-rate float charger begins recharging the battery. The battery is fully restored in 72 hours.

The **ELI-S-250** does not affect normal fixture operation and may be used with a switched or unswitched fixture. It is designed for surface mounting and may be installed up to 1,000 feet from the emergency fixture. It can be used with indoor and outdoor lighting applications. The **ELI-S-250** is UL Listed for field installation.



Product Highlights

- Compatible with LED, fluorescent or incandescent fixtures up to 250VA
- Supplies 90 minutes of emergency illumination
- Features sinusoidal output
- Provides power to the input side of the fixture(s), including the ballast
- Includes brownout sensing circuit to help ensure proper operation during low line conditions
- Temperature rating: 68° F to 86° F (20° C to 30° C)
- Dimensions: 18.127" x 10.125" x 8.243"
(460 mm x 257 mm x 209 mm)
- Weight: 89 lbs (40.37 kg) with batteries installed
- Warranty: Unit, 5 years; Battery, 3 years, +7 years pro-rated
- UL Listed for field installation

Dimming option for the ELI-S-250 available 2015 Q4.



Model	Feature
ELI-S-250	250 W



The ELI-250 is ideal for schools, restaurants, office buildings, stairways and many other locations.

Special Applications

Products for Meeting Specific Requirements

Emergency lighting is included in facility planning because it is a critical life safety component. It helps guide building occupants along the path of egress during the loss of normal power. Unfortunately, the path of egress may involve special considerations.

Philips Emergency Lighting manufactures special application products to meet such needs.

Universal Input

Philips Emergency Lighting's universal input fluorescent emergency ballasts are designed for an input voltage range of 120 through 277 (50 or 60 Hz) and offer a number of advantages over standard emergency ballasts. They minimize inventories, simplify wiring and tolerate harsh line conditions. Recommended applications for Philips Bodine universal products include fixtures subject to international line voltages; in drilling rigs where generators are the primary source of power; and exposed to noticeable line voltage variation or harmonic distortion.

Extended Runtime

While 90 minutes is the standard code-required time for emergency lighting operation, there are cases in which a greater runtime is required or desired. Hospitals, grade schools and assisted-living facilities, for example, might benefit from a longer runtime. Philips Bodine extended runtime fluorescent emergency ballasts provide two- and four-hour runtimes to accommodate special applications.

Central Battery Backup

For facilities that have dedicated systems and a central battery supply, the Philips Bodine **CB 90-48** Central Battery Backup Ballast provides instant emergency illumination to existing fluorescent fixtures when AC power is lost.

Open Circuit Design Emergency Ballasts

Philips Bodine CF open circuit design fluorescent emergency ballasts permit emergency lighting for space-constrained fixtures. The CF units are essentially Philips Bodine emergency ballasts without the can. They consist of a battery and an open circuit board with a charger and electronic components. Four different battery configurations are available for each product. The design and the battery options allow for remarkable installation flexibility. Philips Bodine open circuit design products are UL Component Recognized for factory installation only.

Please visit our website for additional product information.
www.philips.com/bodine

Hazardous Location

Locations such as oil refineries, paint booths and textile mills are associated with potential fire and explosion hazards, including combustible gases, liquids, dust and fibers. Philips Bodine fluorescent emergency ballasts for hazardous (classified) location fixtures are UL Component Recognized for factory installation only and are suitable for use in Class I, Division II type fixtures.



Model	Type of Lamps Operated	Max. Lumens*	Feature
B54 (4hrs)	(2'-4') T8s, T9s, T10s or T12s	450	Four-hour emergency illumination
B70A (2hrs)	(2'-8') T8s, T9s, T10s or T12s	700	Two-hour emergency illumination
BHD55U**	(2'-4') T5s; (2'-5') T8s; (4-pin) long compacts	1200	Universal input; Suitable for Class 1, Division II applications
BHD65U**	(2'-8') T8s, T9s, T10s or T12s	700	Universal input; Suitable for Class 1, Division II applications
BHD94GU	(4-pin) 18 -42 W CFLs	750	Universal input; Suitable for low-mercury lamps
BSL310HAZ	LED loads 10 - 50 VDC	1300	Hazardous location; Suitable for Class 2 output
CF94GU**	(4-pin) twins, quads, triple twin-tubes or long compacts	700	Universal input; Open circuit design

* Refer to specific model specification sheets for lumen output by lamp type.

** Factory installation only

Product Summary for Fluorescent Emergency Ballasts



Linear

Model	Lamps	Type of Lamps Operated	Max Lumens	Feature
B33	2 or 3	Two or three 32 W (4') T8s. For use with instant start parallel AC ballasts only	3400	Optimized for two- or three-lamp parallel emergency operation
B30	1 or 2	One 17-215 W (2'-8') or two 17-40 W (2'-4') T8, T9, T10 or T12 lamps; or one 21-54 W (2'-4') standard or high output T5	3500	Full lumen output except T5
B30HV	1 or 2	One 14-215 W (2'-8') or two 17-40 W (2'-4') T5, T8, T9, T10 or T12 lamps; one standard or high output T5 lamps; or one 16-55W (4-pin) 2D lamp	3500	High voltage, high bay operation; 347-480 VAC
B30ST	1 or 2	One 17-215 W (2'-8') or two 17-40 W (2'-4') T8, T9, T10 or T12 lamps; or one 21-54 W (2'-4') standard or high output T5	3500	Automatic self-testing
B50	1 or 2	One 17-215 W (2'-8') or two 17-40 W (2'-4') T5, T8, T9, T10 or one T12 long compact lamp	1400	Specification grade; Universal input, AC/DC output
B50 Cold-Pak	1 or 2	One 17-215 W (2'-8') or two 17-40 W (2'-4') T8, T9, T10 or T12 lamps	1200	Extreme temperatures
B50ST	1 or 2	One 17-215 W (2'-8') or two 17-40 W (2'-4') T8, T9, T10 or T12 lamps	1400	Automatic self-testing; Universal input
B60	1 or 2	One 32-215 W (2'-8') or two 32-40 W (2'-4') T8, T9, T10 or T12 lamps	700	Standard grade
B60LP	1 or 2	One 32-215 W (2'-8') or two 32-40 W (2'-4') T8, T9, T10 or T12 lamps	700	Low-profile
B70A	1	One 32-215 W (2'-8') T8, T10 or T12 lamp. 2-hr runtime. Not recommended with reduced-wattage, energy-saving T8 lamps	700	Extended runtime
B90	1	One 32-215 W (2'-8') T8, T10 or T12 lamp. Not recommended with reduced-wattage, energy-saving T8 lamps	600	Economical alternative
B100	1	One 32-40 W (2'-4') T8, T10 or T12 lamp. Not recommended with reduced-wattage, energy-saving T8 lamps	450	Minimum code-compliance
LP600STU	1	One 14-54 W (2'-4') standard or high output T5; 17-55 W (2'-5') T8; or 22-55 W T5 circline; long compacts	1325	Automatic self-test; Universal input; Low-profile
LP600	1	One 14-54 W (2'-4') standard or high output T5; 17-55 W (2'-5') T8; or 22-55 W T5 circline; long compacts	1325	Damp locations; Low-profile
LP550	1	One 14-54 W (2'-4') standard or high output T5; 32-44 W (4'-5') standard or high output T8; long compacts	700	Damp locations; Low-profile
LP500	1	One 21-54 W (2'-4') standard or high output T5 or 32 W (4') T8; long compacts	700	Damp locations; Low-profile
B50LP	1 or 2	One 17-215 W (2'-8') or two 17-40 W (2'-4') T8, T9, T10 or T12 lamps	1300	Damp locations; Low-profile



Compact

Model	Lamps	Type of Lamps Operated	Max Lumens	Feature
B30HV	1 or 2	One 18-42 W compact fluorescent lamp. Also one 14-215 W (2'-8') or two 17-40 W (2'-4') T5, T8, T9, T10 or T12 lamps; one standard or high output T5 lamps; or one 16-55W (4-pin) 2D lamp	3500	High voltage, high bay operation; 347-480 VAC
B75C	1	One 32-70 W (4-pin) triple twin-tube	1300	Low-mercury (green) lamps
B84CG	1	One 13-42 W (4-pin) twin, quad or triple twin-tube lamp; one 22-40 W T5 circline; or one 18-39 W long compact	1250	Low-mercury (green) lamps
B94GU	1	One 13-42 W (4-pin) twin, quad or triple twin-tube	750	Low-mercury (green) lamps; Universal input
B4CFG	1	One 13-42 W (4-pin) twin, quad or triple twin-tube; one 22-40 W T5 circline; or one 18-39 W long compact	1250	Low-mercury (green) lamps
B4CF1 Cold-Pak	1	One 13-42 W (4-pin) twin, quad or triple twin-tube; one 22-40 W T5 circline; or one 18-39 W long compact	1250	Extreme temperatures
B4CF2 Cold-Pak	1	One 13-42 W (4-pin) twin, quad or triple twin-tube; one 22-40 W T5 circline; or one 18-39 W long compact	1250	Extreme temperatures
B4CF2P	1 or 2	One 13-42 W or two parallel 13-26 W (4-pin) twin, quad or triple twin-tube lamps; one 18-39 W or two parallel 18-27 W long compacts; or one 22-40 W T5 circline	925	Parallel operation
B4CF2P Cold-Pak	1 or 2	One 13-42 W or two parallel 13-26 W (4-pin) twin, quad or triple twin-tube lamps; one 18-39 W or two parallel 18-27 W long compacts; or one 22-40 W T5 circline	925	Extreme temps; Parallel operation
B4CF2PC	1 or 2	One 13-42 W or two parallel 13-26 W (4-pin) twin, quad or triple twin-tube lamps; one 18-39 W or two parallel 18-27 W long compacts; or one 22-40 W T5 circline	925	Parallel operation; With conduit
B4CF2PC Cold-Pak	1 or 2	One 13-42 W or two parallel 13-26 W (4-pin) twin, quad or triple twin-tube lamps; one 18-39 W or two parallel 18-27 W long compacts; or one 22-40 W T5 circline	925	Extreme temps; Parallel operation; With conduit
B4CF3 Cold-Pak	1	One 13-42 W (4-pin) twin, quad or triple twin-tube; one 22-40 W T5 circline; or one 18-39 W long compact	1250	Extreme temps; Alternate case size

Special App FEBS (UL Component Recognized for factory installation only)

Model	Lamps	Type of Lamps Operated	Max Lumens	Feature
CF94GU	1	One (4-pin) twin, quad or triple twin-tube	700	Open circuit design; Universal input
BHD94GU	1	(4-pin) 18 -42 W CFLs	750	Hazardous locations; Universal input
BHD55U	1	One 14-54 W (2'-4') T5 bipin; 22-40 W T5 circular; 36-55 W (4-pin) long compact; or 17-55 W (2'-5') T8 bipin	1200	Hazardous locations; Universal input
BHD65U	1 or 2	One 17-215W (2'-8') or two 17-40 W (2'-4') T9, T10 or T12 lamps	700	Hazardous locations; Universal input

LED

Product Summary & Selection Guide

1. Is your application a screw-in LED lamp or linear LED lamp with an integrated (internal) AC driver?



ELI-S-20	Supports up to 25W of emergency illumination at full brightness for a minimum of 90 minutes. Provides input power to the integral LED driver at line voltage (120 or 277V) and at line frequency (sinusoidal 60Hz).
ELI-S-100	Supports up to 100W of emergency illumination for a minimum of 90 minutes in emergency mode. Offers two important features for LED applications: dimming capabilities and sinusoidal output. May be connected to one or multiple fixtures. Available in ELI-S-100-120V model and ELI-S-100-277V model.
ELI-S-250	Supports up to 250VA of emergency illumination at full brightness for a minimum of 90 minutes. Features an LED-friendly sinusoidal (sine) waveform output. Sinusoidal waveform is characterized by very low harmonic distortion and by clean power similar to that produced by utility-supplied electricity.

Note: ELI Series inverters also operate compact fluorescent lamps and incandescent lamps.

2. If your LED application uses an external AC driver and LED array:



Model	Maximum Output Power	Flexible Output Voltage	Feature
BSL10 Cold-Pak	10.0 W* controlled output	24 - 52 VDC	Operates in an extended-temperature range of -20°C to +55°C
BSL17C	7.0 W* controlled output	30 - 80 VDC	Up to 7.0 W emergency illumination with LEDs
BSL17C-C2	7.0 W* controlled output	15 - 50 VDC	Compatible with Philips Fortimo; Class 2 output
BSL17C-C2ST	7.0 W* controlled output	15 - 50 VDC	Compatible with Philips Fortimo; self-testing; Class 2 output
BSL20LV	20.0 W* controlled output	20 - 50 VDC	High output emergency LED driver; 20W constant output power; Class 2 output
BSL20MV	20.0 W* controlled output	50 - 130 VDC	High output emergency LED driver; 20W constant output power; Class 2 output
BSL20HV	20.0 W* controlled output	125 - 200 VDC	High output emergency LED driver; 20W constant output power; Class 2 output
BSL23C	4.5 W	3 - 20 VDC	Up to 4.5 W emergency illumination with LEDs
BSL26C	5.1 W*	3 - 30 VDC	Up to 5.1 W emergency illumination with LEDs
BSL26C	5.1 W	3 - 30 VDC	Up to 5.1 W emergency illumination with LEDs
BSL36LP	6.0 W* controlled output	15 - 52 VDC	Low-profile emergency LED driver; Class 2 output
BSL310CP	10.0 W*	10 - 50 VDC	Compatible with CREE LMH Modules
BSL310LP	10.0 W* controlled output	15 - 52 VDC	Low-profile emergency LED driver; Class 2 output
BSL310LPST	10.0 W* controlled output	15 - 52 VDC	Low-profile, self-testing emergency LED driver; Class 2 output
BSL310HAZ	10.0 W*	10 - 50 VDC	LED hazardous location Class 2 output
BSL310SB	10.0 W*	10 - 50 VDC	Linear LED strips; Class 2 output; Separate battery for more flexible installation
BSL722	23.1 W	28 - 33 VDC	Drives 2 LED arrays in parallel using 2 external battery packs
BSL722 Cold-Pak	23.1 W	28 - 33 VDC	Drives 2 LED arrays in parallel using 2 external battery packs; operates in extended temps

* Measured at nominal battery voltage.

Disclaimer

The information in this guide is accurate at the time of writing. This guide is provided "as is" without expressed or implied warranty of any kind. Neither Philips nor its agents assume any liability for inaccuracies in this guide or losses incurred by use or misuse of the information in this guide. Philips will not be liable for any indirect, special, incidental or consequential damages (including damages for loss of business, loss of profits or the like), whether based on breach of contract, tort (including negligence), product liability or otherwise, even if Philips or its representatives have been advised of the possibility of such damages.



©2015 Koninklijke Philips N.V. All rights reserved. Philips reserves the right to make changes in specifications and/or to discontinue any product at any time without notice or obligation and will not be liable for any consequences resulting from the use of this publication.

Document order number: L0000031 15.1028 philips.com/bodine

Philips Emergency Lighting
236 Mt. Pleasant Road
Collierville, TN 38017
Tel. 901-853-7211