

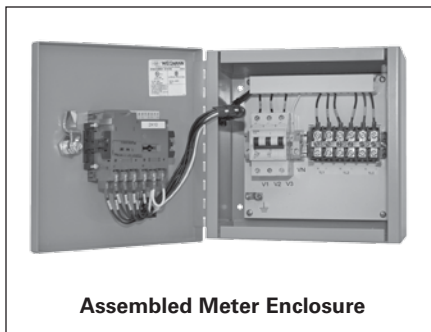

WinPM.Net



Powermanager Software



Assembled Meter Enclosure



Power Meters

Contents

Power Distributions Solutions

Introduction

Power Monitoring Systems Overview	8-2
Intelligent Metering and Control Devices	8-3

Power Meters

PAC3100	8-4
PAC3200	8-5
PAC4200	8-6
9410	8-7
9510 / 9610	8-8 – 8-9
9510 RTU Advanced Data Recorder	8-10
Enclosed Meters	8-11
Branch Circuit Monitoring/ SEM3 Embedded Micro Sub Metering	8-17
Embedded Micro Metering Module™	8-19
MD Series Power Meter	8-21
Low-voltage Current Transformers	8-22

Energy Management Software

Powermanager Software	8-24
WinPM.Net Software	8-25

Application Engineering

Application Engineering	8-26
Services	8-27

Siemens recognizes that high performance facilities make for high performance business. Energy is the lifeline of your business, and better efficiency and sustainability can have a large positive impact on your bottom line.

Energy Management and Control Systems from Siemens are complete enterprise solutions that help you manage the energy costs and availability of your business. With our advanced meters and controls, you can be sure to use only the energy you need, when you need it.

Siemens Power Distribution Solutions contribute toward achieving LEED® certification and provides the needed energy metering data for federal/local government energy reductions programs.

Features and Benefits of Siemens Power Distribution Solutions:

- | | |
|---|---|
| <ul style="list-style-type: none"> Power Quality Reliability & Analysis Utilities Cost Allocation & Billing Utilities Usage Aggregation Load Preservation Equipment Monitoring Facility Monitoring & Automation Sequence of Event Recording Preventative Maintenance Electrical Asset Management | <h3>Energy Management</h3> <ul style="list-style-type: none"> Branch Circuit Monitoring Sub-Billing and Cost Allocation Application Engineering Services Agreements Network/Communication Components Integration with Existing SCADA/BAS Systems Incorporation of Third Party Devices |
|---|---|

Totally Integrated Power

System Overview

General

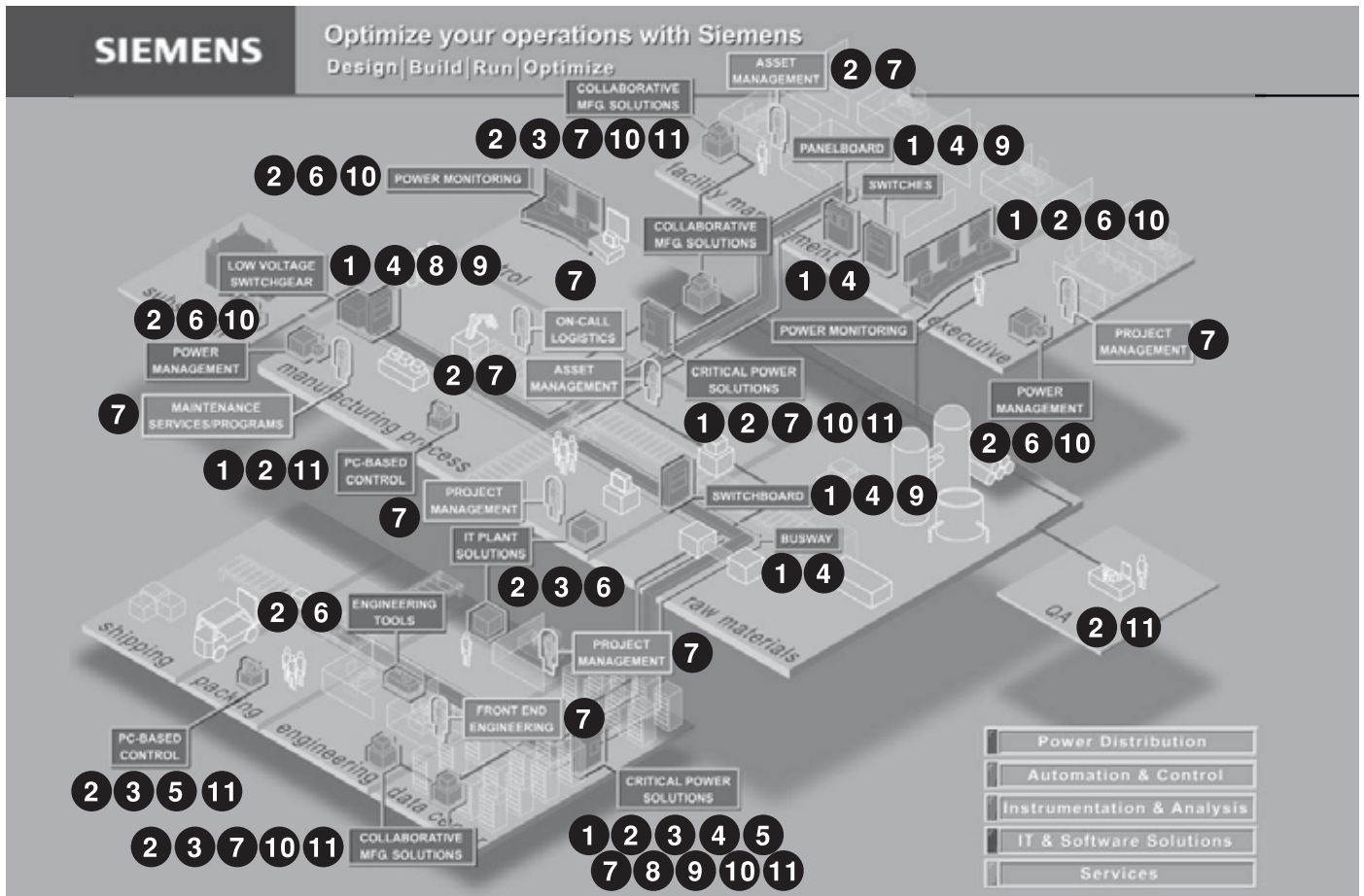

1. Power Meters

Siemens' ACCESS power monitors combine the best of new technologies and proven practices. Monitor critical loads, power quality, and demand via the web directly from the meters.

2. Power Monitoring Software

WinPM.Net web-enabled software facilitates easy, enterprise-wide connection to power monitoring equipment, circuit breakers, and other devices from Siemens and third parties. Access information via the web with unlimited no-cost clients using built-in WebReach™ via your web browser.

3. Communications Networks

Utilize existing Ethernet or RS-485 communications networks to extract the information you need and get it where it needs to go.

4. Components

Current Transformers (CTs), Voltage/Potential Transformers (PTs), Power Supplies, Ethernet Switches, Protocol Converters. Siemens can provide everything required for your system.

5. Intelligent I/O

Our S7 I/O enables plug-n-play communications with Modbus devices and expands digital and analog input and output functionality of ACCESS Systems.

6. Billing and Load Allocation Software

ACCESS Energy Manager is the low-cost, simplified solution for cost allocation, billing & load/demand analysis using your web browser.

7. Engineering Services

PDS Application Engineers can help from design through commissioning of even the most demanding power quality and monitoring systems.

8. Motor Control Centres

Monitor mains and feeders for critical or power-intensive loads. Communicate with breakers (Static Trip III, SBEC), SAMMS, SIMOCODE, I/O and devices from other manufacturers. Use ACCESS power meters to web-enable new as well as existing MCCs.

9. Low & Medium Voltage Switchgear

Web-enable switchgear by having ACCESS monitor power as well as breaker status and upload the information to a corporate Intranet or to the Internet. Use MeterMail™ directly from meters for alarm conditions or simple reporting.

10. Facility Management Systems

Tie into building automation systems to provide the required power and energy information. Lots of communications options are available ranging from legacy protocols to XML directly from the power monitors.

11. Distributed Control Systems, Automation, and SCADA/Human Machine Interface

ACCESS power monitors and/or software can talk to all major vendors' systems.

Intelligent Metering and Control Devices



	PAC3100	MDMeter	SEM3	PAC3200	PAC4200	9410	9510 ADR	9510	9610/9610H
Power, energy and demand									
Voltage/current: per phase, average	■	■	■	■	■	■		■	■
Voltage/current: unbalance	■			■	■	■		■	■
Power: real, reactive, apparent, power factor, frequency kW/kWh	■	■	■	■	■	■		■	■
Energy: bi-directional, import, export	■	■	■	■	■	■		■	■
Energy: total, net	■	■	■	■	■	■		■	■
Demand: block, sliding window	■	■	■	■	■	■		■	■
Demand: thermal predicted						■		■	■
Power quality analysis									
Sag/swell monitoring						■		■	■
Voltage disturbance direction detection						■			■
Transient detection, microseconds									17 µs @ 60 Hz/ 20 µs @ 50 Hz
Harmonics (individual, even, odd, total) up to				THD only	31st	63rd		63rd	127th/255th
Sampling rate, maximum samples/cycle	64		166	64	204	256		256	512/1024
Flicker, harmonics to EN50160, IEC 6100-4-7 / 4-15									■
Configurable for IEEE 519-1992, IEEE 1159, SEM/ITIC									■
Data and wave form logs									
Triggered by setpoint, schedule, or external signal						■	■	■	■
Sequence-of-event logs, variable log depth					■	■	■	■	■
Minimum/maximum logs				■	■	■		■	■
Historical logs / maximum # of channels			■			800	800	800	800
Waveform recording						■	■	■	■
Time-stamps, resolution in seconds				1.0	0.1	0.001	0.001	0.001	0.001
Event log			1.0			■	■	■	■
GPS time synchronization			■			■	■	■	■
Waveform in COMTRADE format with FTP					SNTP	■	■	■	■
Communication Ports, Protocols and I/O									
() = Optional									
RS-232/485 ports							1	1	1
RS-485-only ports	1	1	1	(1)	(1)	1	2	2	2
Ethernet ports		1	1	1	1	2	(1)	(1)	(1)
Infrared optical ports							1	1	1
PROFIBUS ports				(1)	(1)				
PROFINET ports				(2)	(2)				
Built-in modems							(1)	(1)	(1)
Modbus RTU Slave on serial, modem or infrared ports (if equipped with modem or infrared port)	1	■	■	(1)	(1)	■	■	■	■
Modbus RTU Master on serial ports						■	■	■	■
Modbus/TCP on Ethernet ports		■	■	■	■	■	■	■	■
Modbus TCP Master over Ethernet						■	■	■	■
BACnet MS/TP		■							
BACnet IP on Ethernet ports		■							
SNMP			■			■		■	■
DNP 3						■		■	■
MV-90 on serial; Ethernet ports							■	■	■
IEC 61850						■		■	■
Ethernet Gateway: 31 other meters accessible via RS-485					■	■	■	■	■
Concurrent Connections over Ethernet		2	4		3	8	(2)	4	4
Email alarming			■			■	■	■	■
On-board web server		■				■	■	■	■
XML			■(JSON)			■	■	■	■
Analog inputs						(16)	■	■	(4)
Analog outputs						(8)	(4)	(4)	(4)
Digital status/counter inputs (standard/optional add-ons)	2	2	2/(44 PLC DI)	1	2/(4)	3/(24)	8/8	8/8	8/8
Digital relay outputs (control/pulse)	2	1	1	1	2/(8)	1/(8)	7	7	7
Setpoints, alarming and control									
Setpoints, minimum response time		■	■	■	■	1/2 cycle	1/2 cycle	1/2 cycle	1/2 cycle
Math, logic, trig, log, linearization formulas				and/or, > <	and/or, > <	■	■	■	■
Single- and multi-condition alarms	■	■	■	■	■	■	■	■	■
Call-out on alarm			■	■	■	■	■	■	■
Revenue metering									
ANSI C12.16 accuracy compliant	1S					■		■	■
ANSI C12.20		0.2	0.2	0.5	0.2	0.2*		0.2	0.2
EN50160 Compliance Reporting						■		■	■
IEC 61000-4-30 Class A/S						■(S)		■(A)	■(A)
IEC 62053-22 replaces IEC 60687 0.2S compliant				■	■	■		■	■
IEC 62053-24 0.5S compliant for Reactive Energy						■		■	■
IEC 60687 0.2S compliant				■	■	■		■	■
IEC 60687 accuracy class 0.5S compliant	■			■	■	■		■	■
ANSI class 2, IEC 1/10 (1A nominal, 10A max)						■		■	■
ANSI class 20, IEC 5/20 (5A nominal, 20A max)						■		■	■
Time-of-use				■	■	■		■	■
Transformer/line loss compensation						■		■	■

Some features are optional. Refer to datasheets for allowable port configurations. Products meet or exceed the accuracy requirements of the standards listed; due to form factors, not all ANSI/IEC compliance tests may apply. Some products certified by third-party laboratory.

PAC3100 Power Meter

General

Basic Monitoring of Electrical Power Systems

The **PAC3100** is a powerful compact power monitoring device that is suitable for use in industrial, government and commercial applications, where basic metering and energy monitoring is required. The meter may be used as a stand alone device monitoring over 25 parameters or as part of an industrial control, building automation or global power monitoring system. Metering and monitoring applications range from simple analog volt and amp meter replacements to stand-alone sub-billing or cost allocation installations.

The PAC3100 has many features not usually found in this price class of meters. A large graphical display supports multiple languages and easy to use menus that can be used to set up the meter. The meter also has built in Modbus RTU communications via a RS485 interface. The meter comes standard with two digital inputs and outputs. One output is suitable for pulse output for export/import real and reactive energy. The other output is controllable from an outside source by way of a Modbus register.

Precision

- ANSI C12.16 Class1s
- Energy Measurement
 - Voltage +/- .1%
 - Current +/- .1%
 - Power Factor +/- 1%
 - Sampling Rate 64/per cycle
- Revenue Accurate
 - Sub Billing
 - Cost Allocation
- Cost Effective

Energy Management

- Energy Consumption
- Demand Control
- Automation Integration
- Solution for LEED® credit
- Monitors Critical Equipment
- Sub Metering

Reliability

- Economical Measurement
 - Commercial
 - Industrial
 - Residential
- Degree of Protection
 - Front – IP65
 - Rear – IP20
- 480V Connected Voltage
- Simple Retrofit Installation
- Integration with Existing Systems

96 mm
3.78 in.

96 mm
3.78 in.

MODBUS RTU

Terminal block for (2) Digital I/O

Terminals for current and voltage

Full Graphic LCD Display to indicate:

- Display title or designation of the displayed measurements
- Phase
- Measured value
- Unit
- Labeling of function keys

Example of operating menu

With an easy-to-read adjustable back lit LCD display, the PAC3100 can be commissioned in only two steps. After selecting the language and setting two parameters (voltage and current inputs), the meter is ready for use.Ⓢ

Order information

Product	Catalog Number
PAC3100 compression terminals AC/DC	7KM3133-0BA00-3AA0
Adapter Plate for 4700/4720 meter cutout	93-47ADAPTER
PAC32/4200 Meter DIN Rail adapter – Meter display will not be seen	7KM9900-0YA00-0AA0
PAC32/4200 Meter DIN Rail 2-adapter – Meter display will not be seen	7KM9900-0XA00-0AA0

Ⓢ Languages included as standard in the meter are English, German, French, Spanish, Italian, Portuguese, Turkish, Russian and Chinese.

PAC3200 Power Meter

Reliable and Precise Monitoring of Electrical Power Systems

The **PAC3200** is a powerful compact power monitoring device that is suitable for use in industrial, government and commercial applications where basic metering and energy monitoring is required. The meter may be used as a stand alone device monitoring over 50 parameters or as part of an industrial control, building automation or global power monitoring system. Metering and monitoring applications range from simple analog volt and amp meter

The PAC3100 has many features not usually found in this replacements to stand-alone sub billing or cost allocation installations with multiple tariffs. The PAC3200 provides open communications using Modbus RTU/TCP, PROFIBUS-DP, and PROFINET protocols for easy integration into any local or remote monitoring system. Simple configuration of the meter can be done from the front display.

Precision

- ANSI C12.20 Class 0.5s
- Energy Measurement
 - Voltage +/- .3%
 - Current +/- .3%
 - Power Factor +/- .5%
 - Sampling Rate 64/per cycle
 - Total Harmonic Distortion (THD)
- Revenue Accurate
 - Sub Billing
 - Cost Allocation
- Cost Effective

Energy Management

- Energy Consumption
- Automation Integration
- Solution for LEED® credit
- Monitors Critical Equipment
- Modbus TCP/RTU
- Industrial Systems
 - PROFIBUS
 - PROFINET

Reliability

- Economical Measurement
 - Commercial
 - Industrial
 - Residential
- Degree of Protection
 - Front – IP65
 - Rear – IP20
- 600V Connected Voltage
- Simple Retrofit Installation
- Integration with Existing Systems



96 mm
3.78 in.

96 mm
3.78 in.



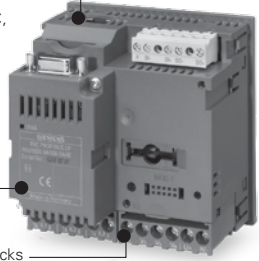

Modbus TCP integrated into the meter as standard

SENTRON PAC, PROFIBUS DP, MODBUS RTU and PROFINET expansion modules for remote data transmission

Terminal blocks for voltage and current measuring, control power and digital input and output (available with compression terminals)

Full Graphic LCD Display to indicate:

- Display title or designation of the displayed measurements
- Phase
- Measured value
- Unit
- Labeling of function keys

Example of operating menu:

The texts can be displayed in several languages, which can be selected directly on the device.① The large graphic LCD display facilitates reading even from a distance. For optimum visibility even in poor light conditions the PAC3200 comes with a gradually adjustable background illumination.

Order information

Product	Catalog Number
PAC3200 compression terminals (not suitable for use with ring tongue terminals), AC/DC	7KM21120BA003AA0
PAC3200 compression terminals (not suitable for use with ring tongue terminals), DC only	7KM21111BA003AA0
PAC PROFIBUS DP expansion module	7KM93000AB000AA0
PAC PROFINET expansion module	7KM93000AE010AA0
PAC MODBUS RTU expansion module	7KM93000AM000AA0
PAC3200/4200 Meter DIN Rail adapter – Meter display will not be seen	7KM99000YA000AA0
PAC3200/4200 Meter DIN Rail 2-Tier adapter – Meter display will not be seen	7KM99000XA000AA0
Adapter Plate for 4700/4720 meter cutout	93-47ADAPTER

① Languages included as standard in the meter are English, German, French, Spanish, Italian, Portuguese, Turkish, Russian and Chinese.

PAC4200 Power Meter

Reliable and Precise Monitoring of Electrical Power Systems

The **PAC4200** is a feature packed power monitoring device that is suitable for use in industrial, government and commercial applications where basic to advanced metering, logging, and I/O is required. The meter may be used as a stand alone device monitoring over 200 parameters or as part of an industrial control, building automation or global enterprise wide monitoring system.

Advanced power quality monitoring and logging applications range from single low-voltage breaker / building metering to sub-station main feeder monitoring, sub-billing or cost allocation installations with multiple tariffs. Whether your goal

is to reduce operation cost, reduce your carbon footprint or to maintain your power assets, the PAC4200 meter should be an important part of your power monitoring system.

The PAC4200 provides open communication using the standard built-in Ethernet Modbus TCP and has the capability of communicating through Optional Modbus RTU, PROFIBUSDP, and PROFINET protocol modules simultaneously. This allows for easy integration into any local or remote monitoring system. The gateway functionality of this device reduces installation cost by replacing other gateway devices and simplifying wiring.

Precision

- ANSI C12.20 Class .2s
- Energy Measurement
 - Voltage +/- .2%
 - Current +/- .2%
 - Power Factor +/- .5%
 - Sampling Rate 170/per cycle
 - Individual Harmonics up to 31st
- Power Quality
- Revenue Accurate
 - Sub Billing
 - Cost Allocation
- Cost Effective

Energy Management

- Serves two masters via the TCP connection
- Energy Consumption
- Min/Max and Event Logs
 - Storage Capacity 40 days at 15 min intervals
 - Event Logging 4000 events
- Demand Control
- Automation Integration
- Modbus Gateway
- Modbus TCP/RTU
- Industrial Systems
 - PROFIBUS
 - PROFINET

Reliability

- Monitors Critical Equipment
- Economical Measurement
 - Commercial
 - Industrial
- Degree of Protection
 - Front – IP65
 - Rear – IP20
- 600V Connected Voltage
- Customizable Displays
- Simple Retrofit Installation
- Integration with Existing Systems
- Solution for LEED® credit

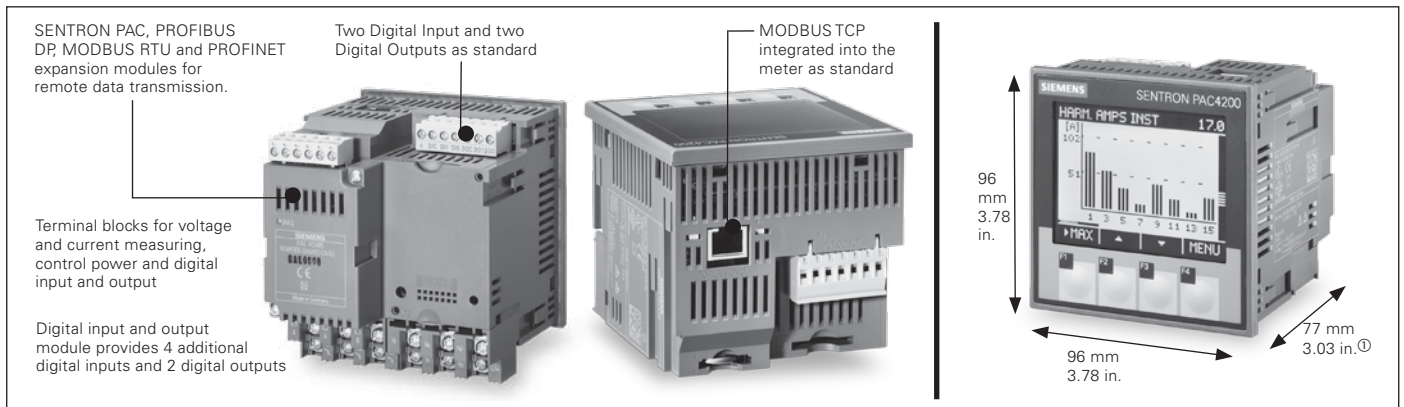

Order information

Product	Catalog Number
PAC4200 compression terminals (not suitable for use with ring tongue terminals), AC/DC	7KM42120BA003AA0
PAC4200 compression terminals (not suitable for use with ring tongue terminals), DC only	7KM42111BA003AA0
PAC PROFIBUS DP expansion module	7KM93000AB000AA0
PAC PROFINET expansion module	7KM93000AE010AA0
PAC I/O expansion module	7KM92000AB000AA0
PAC MODBUS RTU expansion module	7KM93000AM000AA0
PAC3200/4200 Meter DIN Rail adapter – Meter display will not be seen	7KM99000YA000AA0
PAC3200/4200 Meter DIN Rail 2-Tier adapter – Meter display will not be seen	7KM99000XA000AA0
Adapter Plate for 4700/4720 meter cutout	93-47ADAPTER

① 99mm, 3.90 in., with expansion module

9410 Web-Enabled Power Quality & Analysis Meter

Reliable and Precise Monitoring of Electrical Power Systems

The 9410 series meters are ideally suited to local and remote monitoring of low or high-voltage electrical installations in industrial facilities, commercial buildings, utility networks or critical power environments. Facility and operations personnel will benefit in energy-related costs while avoiding power quality conditions that can reduce equipment life and productivity.

The 9410 series meter is easy to install and use, offering integrated or remote high-visibility displays. A range of expansion modules help match features to the application and support field-upgrading of meters as required. Serial and Ethernet communication enable the meter to be used within a WinPM.Net power management system or with third-party management systems.



Precision

- ANSI C12.20 Class 0.2s
 - Energy Measurement
 - Voltage +/- .1%
 - Current +/- .1%
 - Power Factor +/- .5%
 - Sampling Rate 256/ per cycle
 - Individual Harmonics up to 63rd
 - Sags / Swells Detection
 - Programmable Math / Logic Function
- Revenue Accurate
 - Sub Billing
 - Cost Allocation

Energy Management

- Energy Consumption
- 9410 Waveform Capture
- Customizable Webpages
- Min/Max and Event Logs
- Demand Control
- Automation Integration
- Solution for LEED® credit
- Monitors Critical Equipment
- Modbus Gateway
- Modbus TCP/RTU
- Modbus Master
- Industrial Systems
- IEC 61850 Protocol

Reliability

- Economical Measurement
 - Commercial
 - Industrial
- Degree of Protection
 - Front – IP54, UL type 12
 - Rear – IP30
- 600V Connected Voltage
- Customizable Displays
- Email Alarms through Ethernet
- Field Addable Modules
- Simple Retrofit Installation
- Integration with Existing Systems

Order information

Product	Catalog Number
9410 Panel meter with integrated colour display, 1 DO, 3 DI, dual port Ethernet	9410DC
9410 DIN transducer meter packaged with remote display (includes 3m cable)	9410RC
9410 Meter without display (DIN rail mount transducer version) with 1 DO, 3 DI, dual port Ethernet	9410TC
Accessories	Catalog Number
9410 Remote colour LCD display, 96 mm x 96 mm, with 3 m cable	948DISP96
9410 I/O Module with 2 relay outputs, and 6 digital inputs (wetted)	948M2DO6DI
9410 I/O Module, 2 analog outputs (4 - 20 mA, 0- 10 VDC), and 4 analog inputs (4 - 20 mA, 0 - 30 VDC)	948M2AO4AI
9410 Voltage and Current Sealing Kit (included with base meter)	9410SK
9410 Remote display cable, 10 meters	948DCAB10
9410 Remote Display Mounting Adapter kit for 4" round hole - requires 9410RC	94PMAK
9410 Replacement hardware kit for 9410 meter	94PMHWK
9410 Replacement hardware kit for remote display	94PMRDHWK

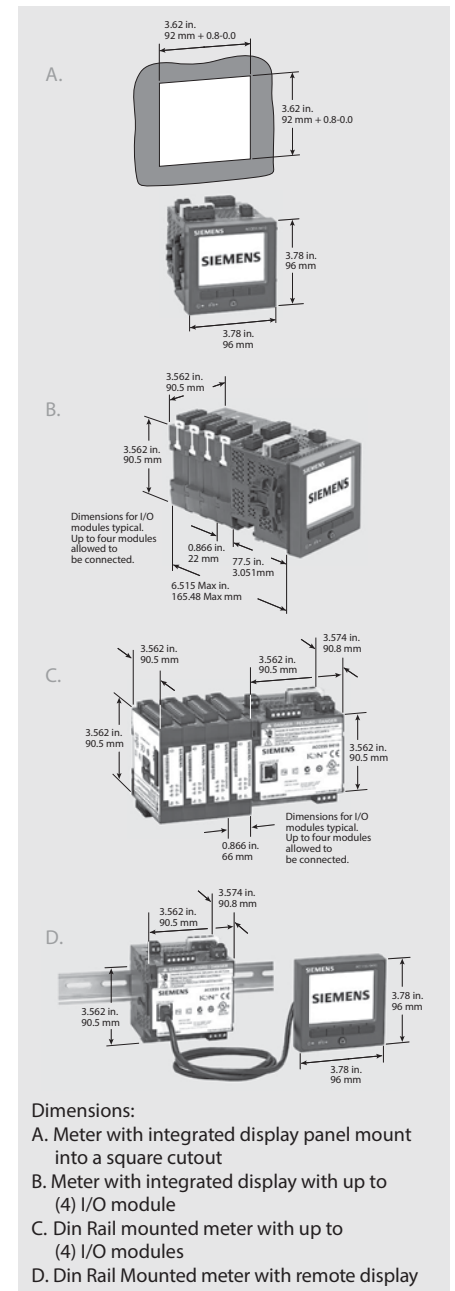

Dimensions:

- A. Meter with integrated display panel mount into a square cutout
- B. Meter with integrated display with up to (4) I/O module
- C. Din Rail mounted meter with up to (4) I/O modules
- D. Din Rail Mounted meter with remote display

9510 / 9610 Power Quality Meter

Power Quality Meter with Web Server Technology

These high power quality meters are packed with features such as the ability to determine the location of a disturbance quickly and accurately and determine the direction of the disturbance relative to the meter. Analysis results are captured in the event log, along with a time-stamp and confidence level indicating level of certainty. The 9510/9610 base meter includes 8 digital inputs capable of providing 1 millisecond time stamping and 7 digital outputs. The 9510/9610 meters support numerous protocols including IEC61850 and Comtrade.

Fast sampling rates and extensive memory make this the perfect choice for critical power systems making analysis of issues possible for correction and prevention. As a data accumulator, the 9510 and 9610 meters can also save money and time by simplifying wiring and networking. Information from the meter and downstream devices can be displayed on the large LCD display, on customizable web pages in reports and screens.

Applications for the 9510 and 9610 meters range from critical power applications such as data centres to industrial, commercial and government power and power quality monitoring systems. The 9510 and 9610 meters are offered in a number of forms from single meter enclosures integrated into Siemens switchgear, switchboard and panelboards. Place these high end power quality meters throughout the power distribution system where critical information is desired. Know what is happening in your facility and get maximum efficiency.



Precision

- ANSI C12.20 Class .2s
- Energy Measurement
 - Voltage +/- .01%
 - Current +/- .01%
 - Power Factor +/- .5%
 - 9510 Sampling Rate 256/per cycle
 - 9610 Sampling Rate 512/per cycle
 - 9610 XH Sampling Rate 1024/per cycle
 - 9510 Individual Harmonics up to 127th
 - 9610 Individual Harmonics up to 256th
 - Sags / Swells Detection
 - Programmable Math / Logic Function
- Revenue Accurate
 - Sub Billing
 - Cost Allocation

Energy Management

- Energy Consumption
- Waveform Capture
- Transient Capture 17 μ s @ 60 Hz
- Disturbance Direction Detection (DDD)
- Customizable Webpages
- Min/Max and Event Logs
 - Storage Capacity up to 3.3 years at 15 min intervals
 - Event Logging up to 20,000
 - Waveform Captures up to 390
- Demand Control
- Automation Integration
- Monitors Critical Equipment
- Modbus Master / Gateway
- Supports Multiple Protocols
- Supports Multiple Master via Ethernet

Reliability

- Economical Measurement
 - Commercial
 - Industrial
- 600V Connected Voltage
- Transformer Line Loss Compensation
- Email Alarms
- Customizable Displays
 - Event / Alarm Log
 - Trending
 - Phasor Diagrams
- Password Protected
- Hardware Lockable
- Supports Copper or Fiber Ethernet
- Integration with Existing Systems

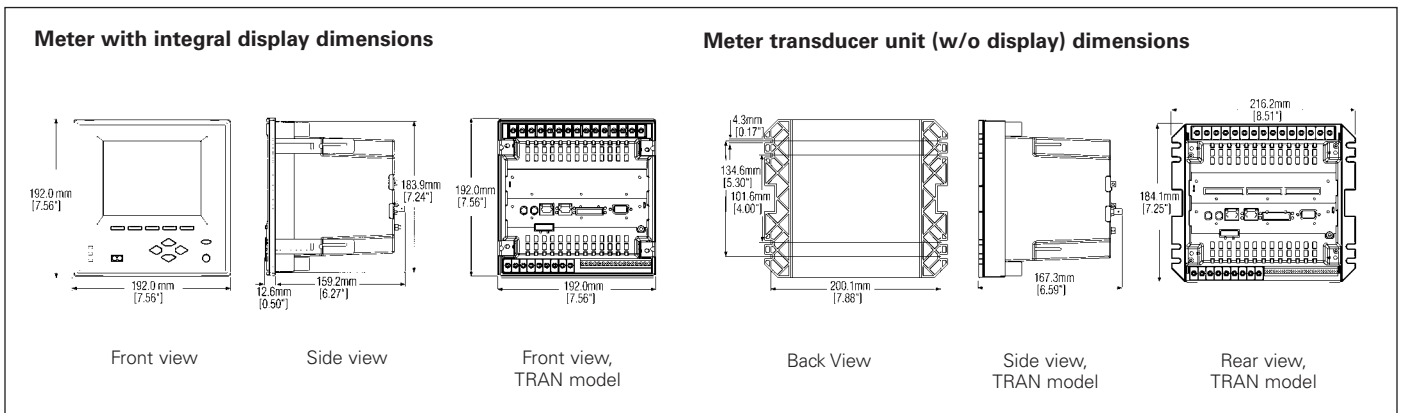

9510 / 9610 Power Quality Meter

Order Information for 95/9610 Power Meters

Catalogue Number

9	X	1	0	D	C	1	1	5	6	C	Z	Z	A
---	---	---	---	---	---	---	---	---	---	---	---	---	---

Description

Meter base unit and display options													
• Meter with integrated display and 5MB logging memory						D							
• Meter with integrated display and 10MB logging memory						E							
• Meter without display (Tran version) and 5MB logging memory						T							
• Meter without display (Tran version) and 10MB logging memory						U							
Sampling rate													
• Standard sampling (256 for 9510) (512 for 9610) per cycle maximum						C							
• 1024 Samples per cycle (9610 only)						H							
Power Supply													
• 85-240 Vac / 110-300 Vdc							1						
• 20-60 Vdc							2						
Input Voltage													
• 120 to 347 L-N / 208 to 600 L-L V AC							1						
Input Current													
• 1A Nominal (10 Amp full scale)							1						
• 5A Nominal (20 Amp full scale)							5						
Frequency													
• 50 Hz								5					
• 60 Hz								6					
Communication Cards													
RS232/RS485 (Selectable)	RS485	Infrared (Note 1)	Modem (Notes 1 & 2)	10/100 Base-T	10/100 Base-FX								A
•	•	•											C
•	•	•		•									G
•	•	•	•	•									H
•	•	•		•	•								J
•	•	•	•	•	•								K
Auxiliary I/O Cards													
• None (base meter includes 8 digital in and 7 digital out)													Z
• 8 Binary Inputs; 4 Analog Inputs 0 to 20 mA and 4 Analog Outputs 0 to 20 mA													F
• 8 Binary Inputs; 4 Analog Inputs 0 to 1 mA and 4 Analog Outputs -1 to 1 mA													G
Tropicalization Option													
• None													Z
• Yes													T
Specials													
• None													A
• Password protected and hardware lockable (lock enabled/disabled via jumper on comm card)													B
• EN50160 Compliance Monitoring (available on 9610 only)													C
• EN50160 Compliance Monitoring with password protected and hardware lockable (lock enabled/disabled via jumper on comm) (available on 9610 only)													D

Note 1 –The infrared and modem connections cannot be operated simultaneously. The connection type is configurable.

Note 2 –The listed modems are not suitable for European applications. Contact Siemens for special versions.

9510 RTU Data Concentrator

Siemens Advanced Data Recorder and Central Display



The **9510-RTU** unit can serve many uses through out a facility. This low-cost central display - data recorder can provide HTML web pages and customizable displays to allow easy access to the data and provide E-mail alarming for critical information. This multi-functional unit supports communications to any Modbus RTU device and digital / analog I/O, allowing the 9510-RTU to provide solutions for many different applications.

Features

- Monitor breaker status changes with 1ms resolution
- Collect, log, and scale pulse inputs from water, air, gas, electricity, or steam meters
- Act as an Ethernet gateway for serial devices
- Display Modbus slave information and make available as a web page
- Log and e-mail down stream Modbus device data
- Display trip unit data from WL, VL, Static Trip III® and SB-EC devices®
- Trigger and email alarms based on set-point conditions
- Display feeder energy information for LEED certification
- Engineering service required to setup the 9510-RTU features

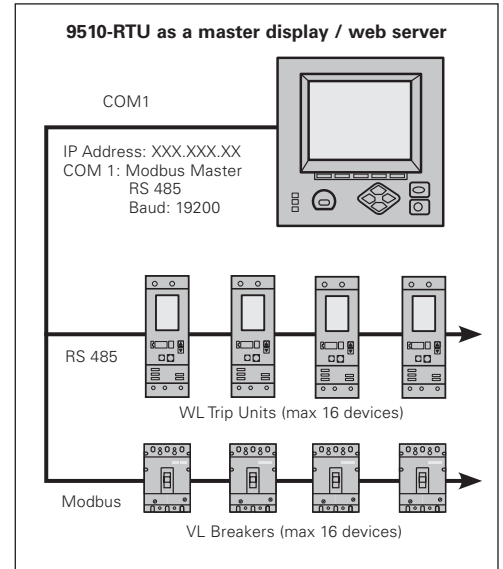

Catalogue Number

9 5 1 0 | E C | 1 R T U | G Z Z A

Description

Meter base unit and display options

Option #1 – Meter with integrated display and 5MB logging memory	D
Option #2 – Meter with integrated display and 10MB logging memory	E
Option #3 – Meter without display, with a 5MB logging memory (TRAN version)	T
Option #4 – Meter without display with a 10MB logging memory (TRAN version)	U

Communications

ION / Modbus RTU - Factory configured for ION

C

Power Supply

85-240 Vac / Vdc

1

20-60 Vdc

2

No Display Option

Remote transducer option

R T U

Communication Cards

RS232/RS485 (Selectable)	RS485	Infrared (Note 1)	Modem (Notes 1 & 2)	10/100 Base-T	10/100 Base-FX	
•	•	•				A
•	•	•	•			C
•	•	•		•		G
•	•	•	•	•		H
•	•	•		•	•	J
•	•	•	•	•	•	K

Auxiliary I/O Cards

None (base meter includes 8 digital in and 7 digital out)

Z

8 binary inputs; 4 Analog Inputs 0 to 20 mA and 4 Analog Outputs 0 to 20 mA

F

8 binary inputs; 4 Analog Inputs 0 to 1 mA and 4 Analog Outputs -1 to 1 mA

G

Tropicalization Option

None

Z

Yes

T

Specials

Standard (password protected, no locking or sealing)

A

Note 1 – The infrared and modem connections cannot be operated simultaneously. The connection type is configurable.

Note 2 – The listed modems are not suitable for European applications. Contact Siemens for special versions.

Enclosed Meters

Convenience and Reliability with Siemens Meter Enclosures

For economical and simple monitoring solutions, turn to Siemens metering units. Installed in rugged NEMA enclosures, these metering units are ideal for;

- Property Management Firms
- Malls
- Government Applications
- Food Courts
- Universities
- Building Retrofits
- Corporate Facilities
- High Rise Condos

The Siemens Meter Enclosure solution is shipped with all the required components pre-installed prior to shipment. The control voltage / voltage taps are wired to a protection device for safety of the meter and wiring and to provide a disconnect from outside power to the meter. Since safety is paramount, the meter CT connections are wired out to shorting blocks and shipped shorted. The enclosure also has a ground lug for equipment grounding. When the control voltage is greater than 240 volts, a CPT is provided between the breaker and the meter.

Siemens will be offering its Enclosed Meter solutions with all of its major Power Meter Options. The following options will be available for selection and application:

Enclosure Types:*

- NEMA 1
- NEMA 3R
- NEMA 12

Power Meter Series:

- PAC Meter Series **
- 9410 Meter Series
- 9510 / 9610 Meter Series
- SEM3 - Embedded Metering Solution



NEMA 1 Enclosure Metering Solution

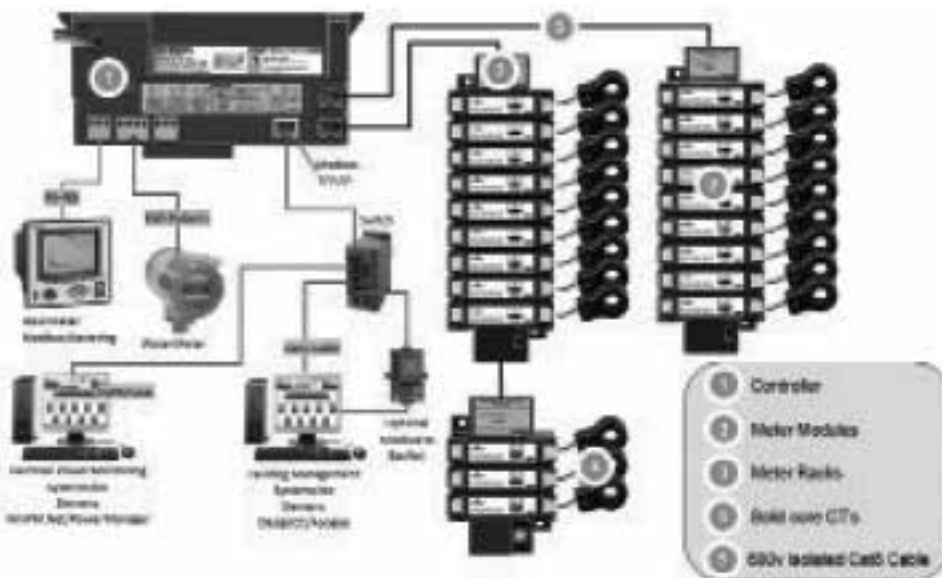

* NEMA 4X Enclosure option is available on special requests.
 ** Includes PAC 3100, 3200 and 4200

Enclosed Meters

Standard PAC Meter

Catalogue Number

E N C L X X X X X X X X X X X

Meter

- 31 PAC3100 Series Meter ①
- 32 PAC3200 Series Meter ②
- 42 PAC4200 Series Meter ②

Voltage

- 240 240 Volts
- 480 480 Volts
- 600 600 Volts

Wiring Configuration

- A 3 phase 3 wire
- B 3 phase 4 wire

Enclosure Type

- 01 Type 1
- 04 Type 4
- 12 Type 12

Communication

- TC Standard
- RT RTU ③
- PD Profibus ③
- PN Profinet ③

Options

- X 4DI + 2DO ④

① PAC3100 standard is Modbus RTU
 ② Only available for PAC3200 and 4200 Meter

③ PAC3200 and 4200 standard is Modbus TCP/IP
 ④ Only available for PAC4200 Meter

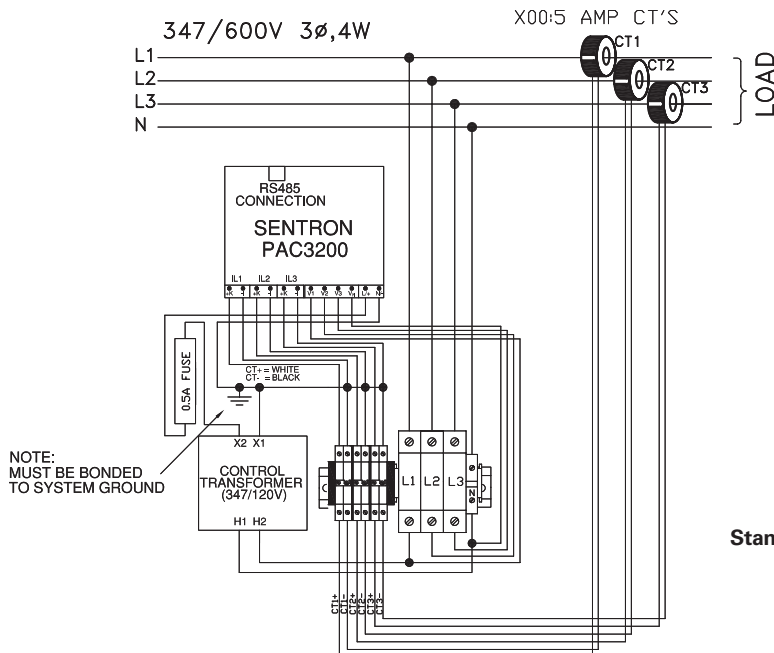

Standard PAC Meter in Enclosure Schematic

Enclosed Meters

Standard 9410 Meter

Catalogue Number

Catalogue No.

E N C L X X X X X X X X X X X X

Meter

- 94DC 9410DC - 9410 meter with integrated display
- 94RC 9419RC - 9410 meter with remote display

Voltage

- 240 240 Volts
- 480 480 Volts
- 600 600 Volts

Wiring Configuration

- A 3 phase 3 wire
- B 3 phase 4 wire

Enclosure Type

- 01 Type 1
- 04 Type 4
- 12 Type 12

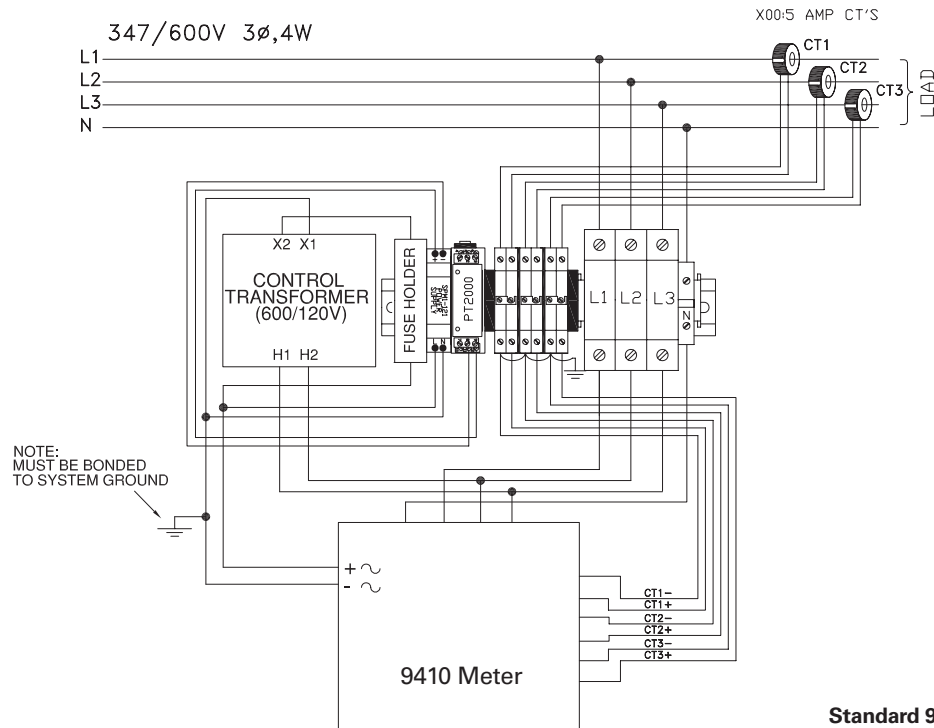

Standard 9410 Meter in Enclosure Schematic

Enclosed Meters

Standard 9510 / 9610 Meter

Catalogue Number

E N C L X X X X X X X X

Meter

95 9510 Meter
 96 9610 Meter

Part no of meter needs to be selected seperately.

Voltage

240 240 Volts
 480 480 Volts
 600 600 Volts

Wiring Configuration

A 3 phase 3 wire
 B 3 phase 4 wire

Enclosure Type

01 Type 1
 04 Type 4
 12 Type 12

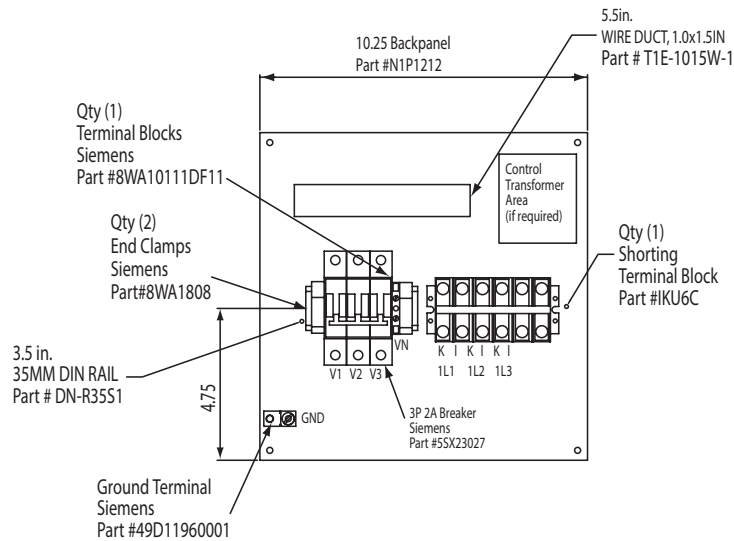

Standard 9510 / 9610 Meter in Enclosure Schematic

Siemens SEM3 - Embedded Metering in Enclosure

For SEM3 in Enclosures, please refer to the selection and application guide for selection of components. Then based on the Enclosure type requirement, please contact our sales team for quote.

Enclosed Meters

Multiple PAC Series Metering Solutions

With safety being paramount, Siemens has designed the SMU with many safety and convenience features in mind. These include a single circuit breaker for both the control voltage & voltage taps to protect internal wiring and the power meters from damage and allowing a "single source" disconnect from outside power, separate CT shorting blocks for each meter, a grounding lug and either the Modbus serial communications or TCP/IP will be terminated to one location for ease of network installation.

If required, a CPT will be provided for control voltages above 240 volts. This complete SMU solution is delivered ready to install with all the components pre-installed prior to shipment.

The Siemens PAC Series Metering Units (SMU) come completely pre-wired and ready to go with our standard PAC3100 and PAC3200 energy meter. The SMU also has the option of adding the PAC4200 meter as gateway. The SMU's can also be supplied with the more advanced Power Meters if required.

Multiple PAC Series Metering Solutions

- Replace multiple meters with one enclosure and save wall space.
- Improve energy efficiency.
- Aggregate Energy Purchases for reduced rates.
- Improve productivity, eliminate manual meter when coupled with Siemens WinPM.Net or other software through automatic reporting software

Typical SMU Network

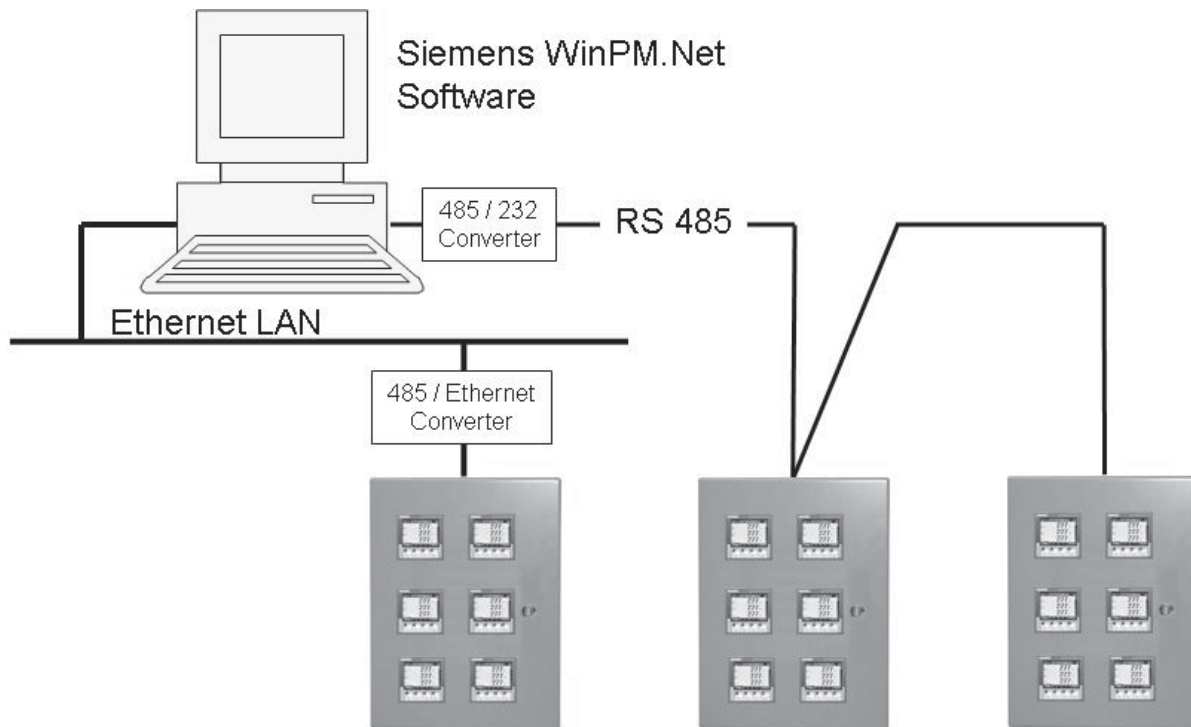

Enclosed Meters

Multiplier Meter in Enclosure

Catalogue Number

E N C L X X X X X X X X X X X

Meter

- 31 PAC3100 Series Meter ①
- 32 PAC3200 Series Meter ②
- 42 PAC4200 Series Meter ②

Voltage

- 240 240 Volts
- 480 480 Volts
- 600 600 Volts

Wiring Configuration

- A 3 phase 3 wire
- B 3 phase 4 wire

Panel Size

- 02 Two Meter Panel
- 03 Three Meter Panel
- 04 Four Meter Panel

Installed Meters

- 02 Two Meters Installed
- 03 Three Meters Installed
- 04 Four Meters Installed

Enclosure Type & Module

- X Type 1
- B Type 12
- C Type 4
- D Type 1 Modbus RTU ③
- F Type 12 Modbus RTU ③
- G Type 4 Modbus RTU ③
- H Type 1 Ethernet ④
- J Type 12 Ethernet ④
- K Type 4 Ethernet ④

Communication

- TC Standard
- RT RTU ③
- PD Profibus ③

① PAC3100 standard is Modbus RTU
 ② PAC3200 and 4200 standard is ModbusTCP/IP
 ③ All Meters will come with Modbus RTU communication.
 ④ All meter will come with TCP/IP protocol.
 PAC3100 meter will have Ethernet converter installed.

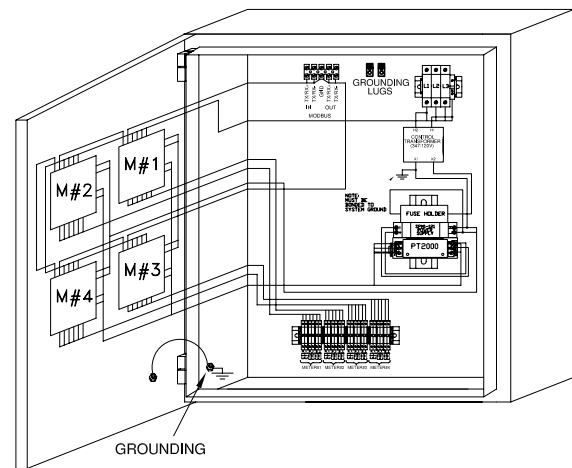

Branch Circuit Monitoring/ SEM3 Embedded Micro Sub Metering

Space Savings, Convenience, and Reliability with Siemens Branch Circuit Monitoring



In a world where tenant square footage is a premium in commercial building designs, the area for electrical metering is being drastically reduced, and critical power is being relied upon in data center applications, Siemens Branch Circuit Monitoring provides the solution.

The Siemens Branch Circuit Monitoring Solution utilizes the metering and monitoring technology integrated into the space saving panelboards from Siemens. When compared to the typical external wall mounted metering installations, considerable savings in space, installation costs, and data collection are realized with the Siemens Branch Circuit Monitoring Solution.

In addition, contractor labour costs for installation of sub-metering systems continues to increase. Still, building owners and property management companies must face the challenges of how to cost effectively provide tenant sub-metering in the constrained spaces.

To meet the sub-metering challenges of designers, contractors and property management companies, Siemens offers a proven cost-effective solution for Branch Circuit Monitoring/Embedded Metering. This solution combines a fully integrated metering system factory installed into the Siemens "P" series panelboards and switchboards, which along with the required local or remote sub-billing software, provides a "Total" sub-metering system.

Siemens Branch Circuit Monitoring / Embedded Metering Solution

- Saves you money – A tenant billing system improves cash flow, allows immediate pass-on of electric rate increases and helps building owners control costs. Tenants are confident they are paying their fair share for energy use and are saving money through energy conservation.
- Fast, low-cost installation – The embedded Siemens solution provides a faster and lower cost installation compared to other external systems.
- Lower space requirements – The embedded panelboard construction design requires no additional wall space to provide tenant metering. Conventional metering requires an external metering enclosure and possibly a current transformer transition cabinet.
- Reliable and accurate – Many Siemens systems are already in operation in large commercial and residential buildings around the country. Their accuracy exceeds utility industry and government standards like EPact 2005 for revenue grade meters.
- LEED certification – Provides the energy monitoring and logging required to achieve additional LEED points.
- Automated billing – With automated billing services the responsibility to acquire the data, store the data and bill the tenants is removed from the property management company, thus saving manpower and time.
- Responsive service – With remote monitoring, continuous 24/7 monitoring can be done by the property management company or tenants. The service can also relay consumption changes to the owners for immediate investigation.

Designer and contractor benefits include:

- Much smaller footprint versus the traditional socket meter combo units
- Factory pre-wired – less installation time
- Drastically less installation wiring
- No CT installation required in the field
- All equipment fits into the standard Siemens panel design
- Additional utilities like water, air and gas can be easily integrated into the system for a comprehensive monitoring system
- Hardwire and wireless communication options
- All components factory calibrated to meet revenue metering requirements
- Additional meters can be added in the field
- UL and CSA-us listed

Branch Circuit Monitoring applications include:

- Mixed Tenant & Retail
- Industrial Manufacturing
- Higher Ed
- Strip Malls
- Critical Power
- Government
- LEEDS buildings
- Airports

Please Contact Your Siemens Sales Engineer for additional information regarding Branch Circuit Monitoring / Embedded Metering

Branch Circuit Monitoring/ SEM3 Embedded Micro Sub Metering

Powerful embedded metering at the source of consumption!

The new Siemens Embedded Micro Metering Module (SEM3) is a modular metering solution for energy monitoring, data analysis, and sub billing applications. The flexible design allows for low, medium, and high density metering requirements to be met efficiently and economically using only a few standardized components.

The SEM3 provides an innovative and cost effective metering solution that can be incorporated into existing applications such as power monitoring, building automation, and sub-billing systems. SEM3 also has the flexibility to be installed as a standalone solution with real time data available from the controller's standard built-in web pages. This metering product has two levels of accuracy to meet the market's differing requirements and price points. This versatile system allows you to meter just the loads you need without the excess hardware and space requirements of traditional or competing solutions.

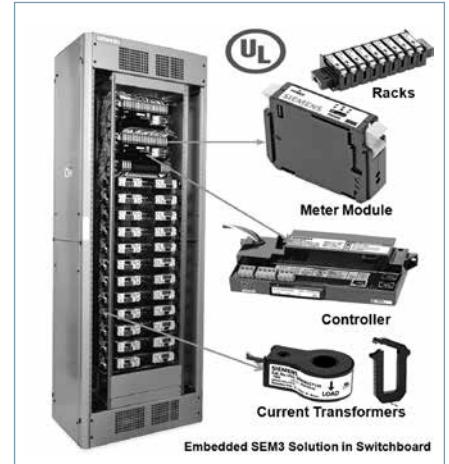

Features & Benefits:

- System designed to meter up to 45 metering points
- Easy retrofit and plug-n-play expansion features
- High metering accuracy up to 0.2%; standard 1.0%
- Built-in HTML web pages for easy configuration & real-time data monitoring for Voltage, Current, Power, Energy, Water, and, Gas
- Modbus RTU, Modbus TCP, SNMP, NTP, BACnet IP & MSTP protocols
- Utilizes milliamp CT's reducing hardware and increasing safety
- Built-in H
- Solid core CT's for high accuracy and split core CT's for easy retrofit.
- Emailing, Alarming, Trending, Totalizing, Event Logging & Data Logging
- Offline Configuration for improving Field and Factory engineering time
- 4 Language support includes English, German, French, and Spanish

Order Information

Controller	Catalog Number	
Main Controller	SEM3CONTROLLER	
Meter Modules		
Meter - Standard Accuracy 1%	SEM3LAMETER	
Meter - High Accuracy 0.2%	SEM3HAMETER	
Meter - Standard Accuracy 1% with Pulse Output	SEM3PLAMETER	
Meter - High Accuracy 0.2% with Pulse Output	SEM3PHAMETER	
Meter Modules		
Meter Rack 3 Position	SEM3RACK3	
Meter Rack 9 Position	SEM3RACK9	
Meter Rack 15 Position	SEM3RACK15	
Meter Rack 21 Position	SEM3RACK21	
Cables		
Controller to Rack Cable - 6 Inch	SEM3CAB6INCH	
Controller to Rack Cable - 12 Inch	SEM3CAB12INCH	
Controller to Rack Cable - 24 Inch	SEM3CAB24INCH	
Controller to Rack Cable - 36 Inch	SEM3CAB36INCH	
Solid Core CT's		
Solid Core CT 50:0.1	SEM3SCCT50	
Solid Core CT 125:0.1	SEM3SCCT125	
Solid Core CT 250:0.1	SEM3SCCT250	
Solid Core CT 400:0.1	SEM3SCCT400	
Solid Core CT 600:0.1	SEM3SCCT600	
Solid Core CT 800:0.1	SEM3SCCT800	
Solid Core CT 1200:0.1	SEM3SCCT1200	
Solid Core CT 1600:0.1 ^⓪	SEM3SCCT1600	
Solid Core CT 2000:0.1 ^⓪	SEM3SCCT2000	
Split Core CT's		
Split Core CT 50:0.1	4LSF0050	
Split Core CT 125:0.1	4LSF0125	
Split Core CT 250:0.1	4LSF0250	
Split Core CT 400:0.1	4LSF0400	
Split Core CT 600:0.1	4LSF0600	
Split Core CT 800:0.1	4LSF0800	
Split Core CT 1200:0.1	4LSF1200	
Split Core CT 1600:0.1 ^⓪	4LSF1600	
Split Core CT 2000:0.1 ^⓪	4LSF2000	

^⓪ 1600 & 2000 Amp CT's may not currently be available. Please contact sales for availability.

Embedded Micro Metering Module™

Selection

Meter Rack
(3, 9, 15, 21)

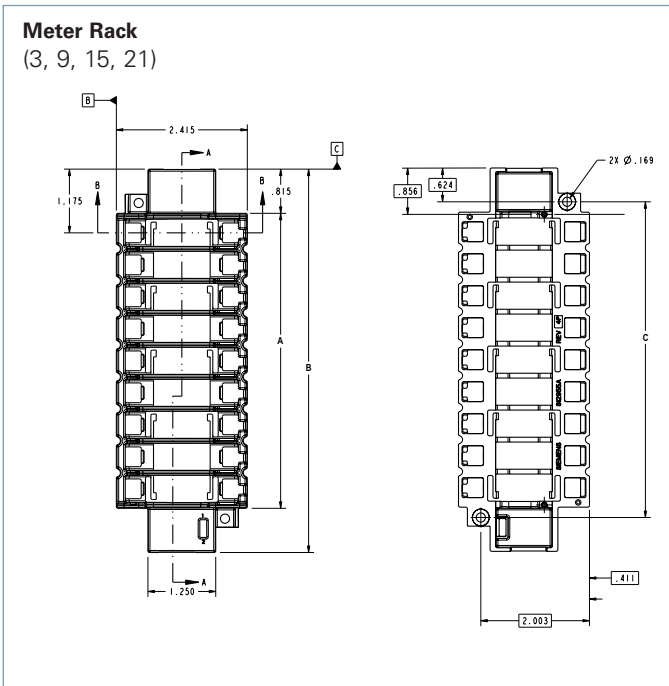

Meter Rack
(3, 9, 15, 21)

Catalogue Number	Description	Variable Dimensions (inches)		
		A	B	C
SEM3RACK3	3 position rack	1.900	3.570	2.282
SEM3RACK6	6 position rack	3.670	5.340	4.050
SEM3RACK9	9 position rack	5.440	7.070	5.822
SEM3RACK15	15 position rack	8.980	10.610	9.362
SEM3RACK21	21 position rack	12.520	14.150	12.902

Controller Dimensions

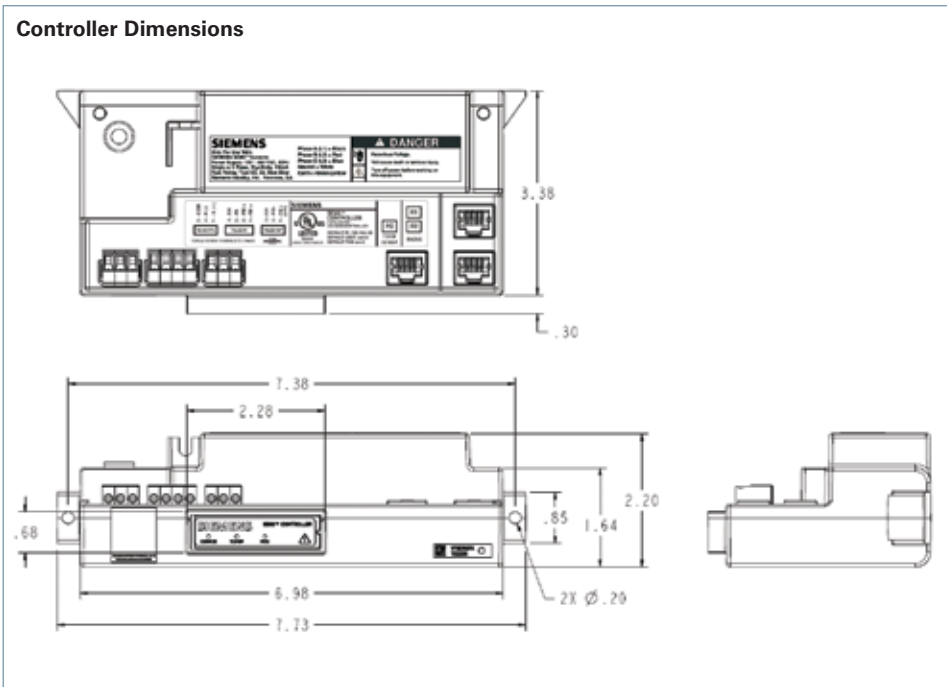

Controller

Catalogue no.
SEM3CONTROLLER

Embedded Micro Metering Module™

Selection

Current Transformer – Solid Core

Description	Catalogue Number	Dimensions (Inches)						
		A	B	C	D	E	F	G
Solid Core CT 50:0.1	SEM3SCCT50	1.4	0.38	0.2	0.92	2.12	0.74	0.37
Solid Core CT 125:0.1	SEM3SCCT125	1.4	0.66	0.2	0.92	2.16	0.74	0.37
Solid Core CT 250:0.1	SEM3SCCT250	1.9	0.93	0.2	0.92	2.75	0.78	0.39
Solid Core CT 400:0.1	SEM3SCCT400	2.62	1.6	0.2	0.92	3.62	0.78	0.39
Solid Core CT 600:0.1	SEM3SCCT600	3.74	2.30	0.24	0.92	4.66	0.78	0.39
Solid Core CT 800:0.1	SEM3SCCT800	4.05	2.60	0.24	0.92	5.05	0.98	0.49
Solid Core CT 1200:0.1	SEM3SCCT1200	4.56	2.80	0.24	0.92	5.57	0.98	0.49
Solid Core CT 1600:0.1	SEM3SCCT1600 ^①	4.50	4.5	6.65	7.05	1.13	—	—
Solid Core CT 2000:0.1	SEM3SCCT2000 ^①	4.50	4.50	6.65	7.05	1.13	—	—

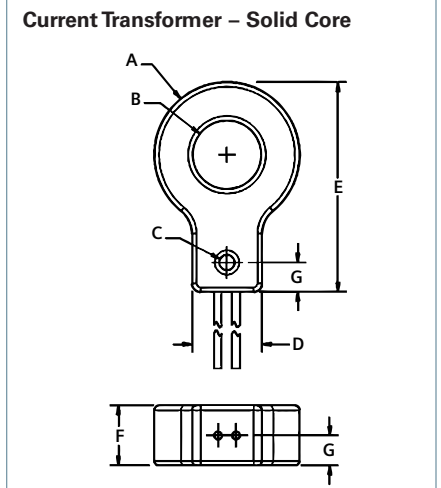

Current Transformer – Split Core

Description	Catalogue Number	A	B	C	D	E
50A Split Core CT	4LSF0050	0.69	0.5	2.32	2.59	0.97
125A Split Core CT	4LSF0125	0.83	0.73	2.38	2.58	0.93
250A Split Core CT	4LSF0250	1.18	1.01	2.87	3.25	1.14
400A Split Core CT	4LSF0400	1.57	1.48	3.66	3.75	1.14
600A Split Core CT	4LSF0600	2.17	2.14	4.32	4.72	1.15
800A Split Core CT	4LSF0800	3.14	3	5.27	5.56	1.16
1200A Split Core CT	4LSF1200	3.02	3.27	5.69	6.48	1.48
1600A Split Core CT	4LSF1600 ^①	4.50	4.50	6.65	7.05	1.13
2000A Split Core CT	4LSF2000 ^①	4.50	4.50	6.65	7.05	1.13

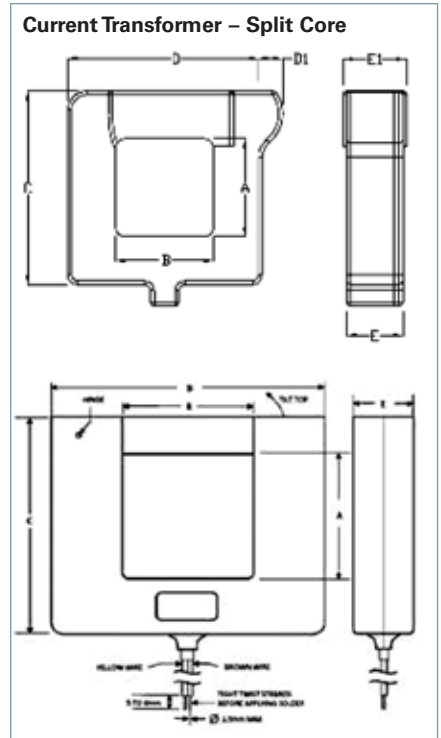

Meter Module

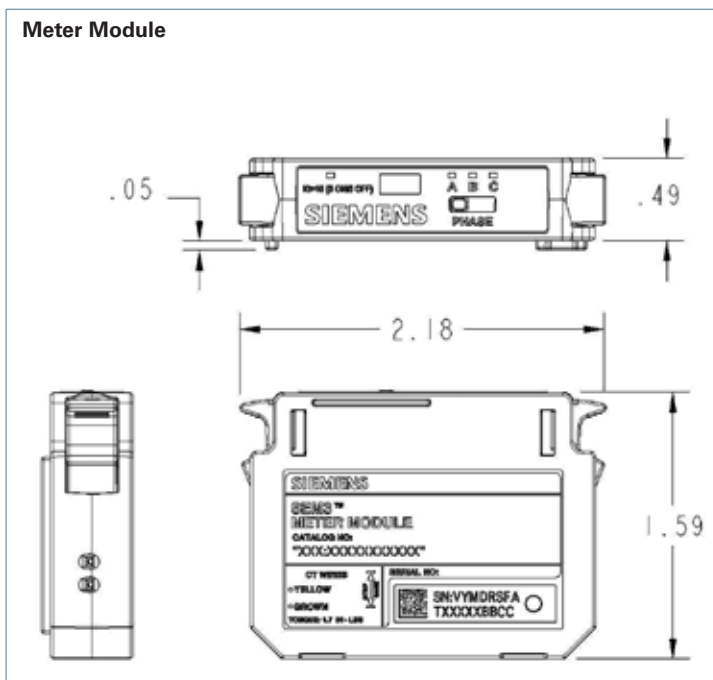

Meter Module

Description	Catalog No.
Meter - Standard Accuracy 1%	SEM3LAMETER
Meter - High Accuracy 0.2%	SEM3HAMETER
Meter - Standard Accuracy 1% with Pulse Output	SEM3PLAMETER ^②
Meter - High Accuracy 0.2% with Pulse Output	SEM3PHAMETER ^②

1600 & 2000 Amp CT's may not currently be available. Please contact sales for availability.
For Pulse output meter modules, please contact Sales for availability.

MD Series Power Meter

MD BM and MD BMD Model Power Meters

Siemens MD BM and MD BMD Model Power Meters are sub metering devices designed to provide real time, accurate electricity metering to enable proper control over energy costs. The meter can capture kWh/kW energy and demand data, as well as virtually all relevant energy parameters for diagnostics and monitoring on three-phase or single-phase circuit installations. The meters' flexibility, size, and ease-of-use make them ideal tools for gathering detailed consumption information in commercial, industrial, governmental, and retail environments. The meters use direct connections to each phase of the voltage and various interchangeable current transformer (CT) options such as splitcore CTs or flexible Rogowski Coils (for large loads or large cables and bus bars) to monitor current on each phase. All of Siemens' current transformers are internally shunted for intrinsically safe operation on energized conductors.

The power meters make over 75 total electrical measurements which are derived from the voltage and current inputs. Electrical load diagnostic parameters such as power factor and line frequency are captured in addition to energy and demand values. The Siemens MD BM and MD BMD Power Meters require no external power and the power supplies can accommodate service voltages ranging from 80 to 600V (phase-to-phase). The simple installation is accomplished by connecting the colour-coded voltage leads and clearly labeled CTs. A three-LED indicator display confirms proper CT-to-phase installation. The meters automatically adjust for CT orientation—greatly reducing set-up time and all but eliminating installation errors.



Product Description	Catalogue Number
MD Meter BACnet-Modbus	MDBM
MD Meter Modbus-BACnet IP	MDBMIP
MD Meter BACnet-Modbus w/display	MDBMD
MD Meter Modbus-BACnet IP w/display	MDBMIPD
Mini SplitCore 0.4 Opening 50A	SCTHSC0050U
Mini SplitCore 0.4 Opening 100A	SCTHMC0100U
Mini SplitCore 0.4 Opening 200A	SCTHMC0200U
Small SplitCore 0.75 Opening 50A	SCTSCS0050U
Small SplitCore 0.75 Opening 100A	SCTSCS0100U
Medium SplitCore 1.25 Opening 100A	SCTSCM0100U
Medium SplitCore 1.25 Opening 200A	SCTSCM0200U
Medium SplitCore 1.25 Opening 400A	SCTSCM0400U
Medium SplitCore 1.25 Opening 600A	SCTSCM0600U
Large SplitCore 2.00 Opening 600A	SCTSCL0600U
Large SplitCore 2.00 Opening 1000A	SCTSCL1000U
Rogowski Coil Current Transformer, 16" (40 cm); 4.5" (11.5 cm) opening; 4000A	SCTR161310U
Rogowski Coil Current Transformer, 24" (60 cm); 7.0" (18 cm) opening; 4000A	SCTR241310U
Rogowski Coil Current Transformer, 36" (90 cm); 10.8 (28 cm) opening; 4000A	SCTR361310U

Low Voltage Current Transformers

Comprehensive metering grade CT offering split-core, flexible and solid core designs

Split core – Rectangular Window

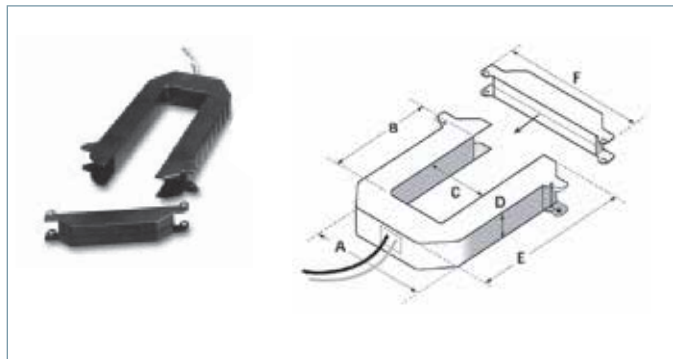

200A – 300A	400A – 800A	1000A – 1200A
A = 3.75" (95mm)	A = 4.90" (124mm)	A = 4.90" (124mm)
B = 1.51" (38mm)	B = 2.89" (73mm)	B = 5.50" (140mm)
C = 1.25" (32mm)	C = 2.45" (62mm)	C = 2.45" (62mm)
D = 1.13" (29mm)	D = 1.13" (29mm)	D = 1.13" (29mm)
E = 4.20" (107mm)	E = 5.57" (141mm)	E = 8.13" (207mm)
F = 4.75" (121mm)	F = 5.91" (150mm)	F = 5.92" (150mm)

Siemens Instrument Grade Current Transformers (CT) have a split-core construction and provide a safe 5A secondary output. These split-core current transformers allow for easy installation, retrofit, and service. CT's come with 4' leads (18 gauge). Use on low voltage applications of 600V or less.

Accuracy 0.5%.

Amps	Window (C x B)	Catalogue Number
100A	1.25"x1.15"	PDS-CTSC-011
200A	1.25"x1.51"	PDS-CTSC-021
300A	1.25"x1.51"	PDS-CTSC-031
400A	2.45"x2.89"	PDC-CTSC-042
600A	2.45"x2.89"	PDS-CTSC-062
800A	2.45"x2.89"	PDS-CTSC-083
1000A	2.45"x5.50"	PDS-CTSC-013
1200A	2.45"x5.50"	PDS-CTSC-123
1600A	2.45"x5.50"	PDS-CTSC-163
2000A	2.45"x5.50"	PDS-CTSC-200
3000A	2.75"x6.625"	PDS-CTSC-03R

Split-core – Round Window

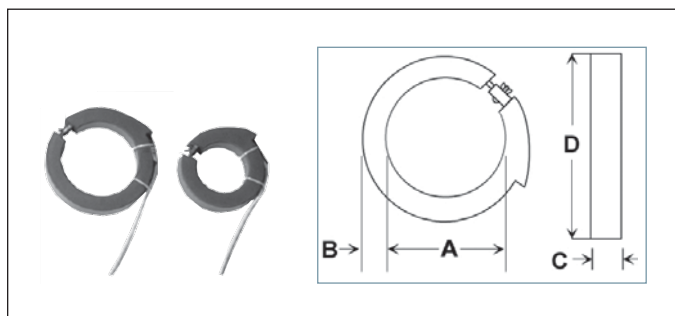

200A – 1200A	3000A – 4000A
A = 4.00"	A = 6.00"
B = 1.25"	B = 1.25"
C = 1.50"	C = 1.50"
D = 6.50"	D = 8.50"

Split-core round rubber insulated flexible CT's with 12' heavy duty leads (18 AWG) and 5A secondary output for use on low voltage applications of 600V.

Accuracy is 4% for 200/400A, 3% for 400A, and 2% for 600A and above.

Amps	Window (A)	Catalogue Number
200A	4.00"	PDS-CTHC-024
300A	4.00"	PDS-CTHC-034
400A	4.00"	PDC-CTHC-044
600A	4.00"	PDS-CTHC-064
800A	4.00"	PDS-CTHC-084
1200A	4.00"	PDS-CTSC-123
2000A	6.00"	PDS-CTHC-206
3000A	6.00"	PDS-CTHC-306
4000A	6.00"	PDS-CTHC-406

Low Voltage Current Transformers

Comprehensive metering grade CT offering split-core, flexible and solid core designs

Solid-core – Round with Round Window

The small size solid core Current Transformer (CT) are designed for tight locations and new installations providing a safe 5 amp secondary for use on voltage applications of 600V or less.

Accuracy is 0.3%.

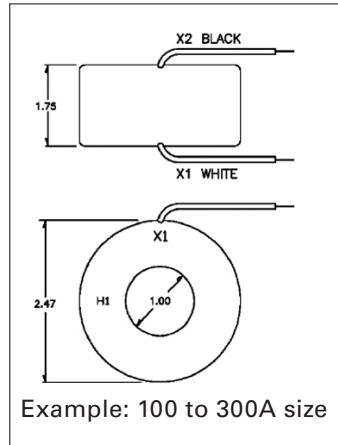

Solid core – Round metering grade, 600V		
Catalogue Number	Primary	Size
SMU-CT-011	100A	1.75" x 2.47"; 1" Window
SMU-CT-021	200A	1.75" x 2.47"; 1" Window
SMU-CT-025	250A	1.75" x 2.47"; 1" Window
SMU-CT-031	300A	1.75" x 2.47"; 1" Window
SMU-CT-041	400A	1.1" x 3.56"; 1.56" Window
SMU-CT-061	600A	1.1" x 3.56"; 1.56" Window
SMU-CT-081	800A	1.1" x 3.56"; 1.56" Window
SMU-CT-123	1000A	1.1" x 3.56"; 1.56" Window
SMU-CT-02R	2000A	1.15" x 5.73"; 3.25" Window

Solid-core – Square with Round Window

Siemens Instrument Grade Current Transformers (CT) are designed as solid-core construction and provide a safe 5A secondary output. Solid-core CT's come with terminals for attaching leads. Use on low voltage applications of 600V or less.

Accuracy is 0.3%.

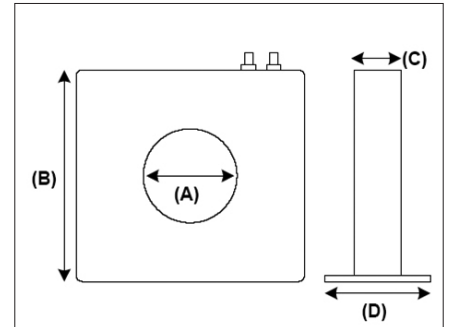

Amps	Dimension (A x B x C x D)	Catalogue Number
200:5	1.25" x 4.88" x 2.19" x 4.68"	PDS-CTRC-021
300:5	1.25" x 4.88" x 2.19" x 4.68"	PDS-CTSC-031
400:5	1.25" x 4.88" x 2.19" x 4.68"	PDS-CTRC-041
500:5	1.25" x 5.10" x 3.00" x 5.50"	PDC-CTRC-051
600:5	1.25" x 5.10" x 3.00" x 5.50"	PDS-CTRC-061
800:5	1.25" x 5.10" x 3.00" x 5.50"	PDS-CTRC-081
1000:5	1.25" x 5.10" x 3.00" x 5.50"	PDS-CTRC-101
100:5	2.25" x 6.31" x 3.00" x 5.82"	PDS-CTRC-012
200:5	2.25" x 6.31" x 3.00" x 5.82"	PDS-CTRC-022
300:5	2.25" x 6.31" x 3.00" x 5.82"	PDS-CTRC-032
400:5	2.25" x 6.31" x 3.00" x 5.82"	PDS-CTRC-042
800:5	4.00" x 6.44" x 3.25" x 3.25"	PDS-CTRC-084
1000:5	4.00" x 6.44" x 3.25" x 3.25"	PDS-CTRC-104
1200:5	4.00" x 6.44" x 3.25" x 3.25"	PDS-CTRC-124
1600:5	4.00" x 6.44" x 3.25" x 3.25"	PDS-CTRC-164
2000:5	4.00" x 6.44" x 3.25" x 3.25"	PDS-CTRC-204
3200:5	6.50" x 9.88" x 7.00" x 7.00"	PDS-CTRC-326
4000:5	6.50" x 9.88" x 7.00" x 7.00"	PDS-CTRC-426

Shorting Block

All low voltage current transformers should be installed with a shorting block to allow for easy removal of the metering unit and to provide a safe method for disconnecting the CT signal. One shorting block is required per meter. Various size shorting blocks are available; 4, 6, and 8 pole configurations are available with four slotted shorting screws and cover. Wire size is 18-10 AWG.

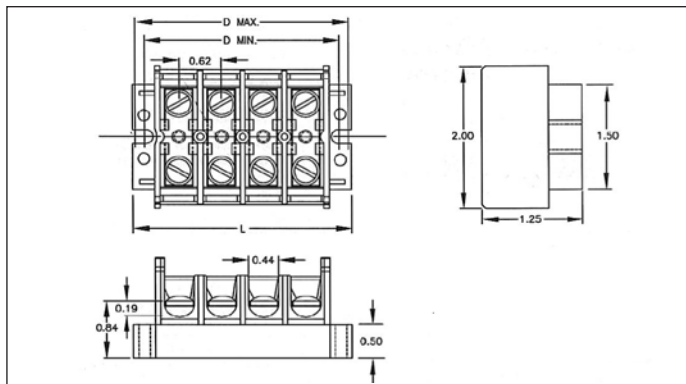

Catalogue Number	Ckts.	Mounting		
		L	D min.	D max.
IKU4SC	4	3.25	2.88	3.00
IKU6SC	6	4.50	4.12	4.25
IKU8SC	8	5.75	5.38	5.50
IKU12SC	12	8.25	7.88	8.00

Typical electrical meter CT and shorting block installation

This example shows a common three phase, three wire installation where three CT's and one shorting block are used.

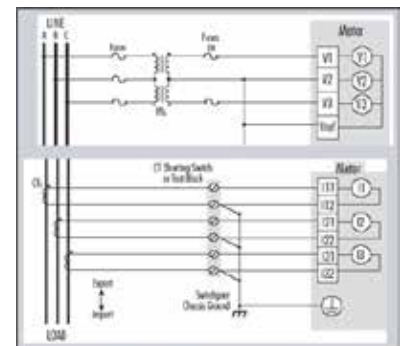

Powermanager

A power management system that can be customized to your needs. View and control your facilities' infrastructure condition from anywhere.

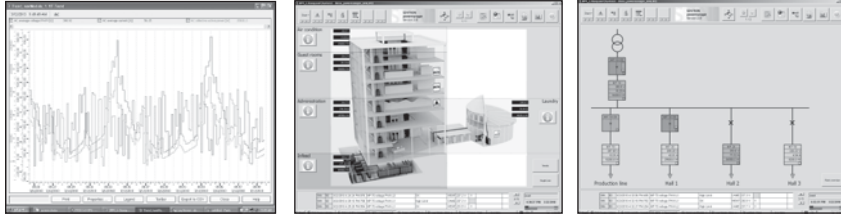

Cost allocation and Sub-billing Reports

Cost allocation and sub-billing functionality in the Powermanager software allows the user to track energy related costs by building, floor, tenant, feeder or location. Match virtually any fixed rate billing structure and use comprehensive multi-year scheduling and time-of-use features to manage the energy costs.

Load Studies and Asset Management

Trend power usage data to take full advantage of your electrical distribution system capacity and avoid over-design. Create usage profiles that will allow you to distribute loads and avoid demand peak which helps to identify energy leaks such as equipment running during down time.

Equipment Monitoring and Control

Powermanager allows you to meter all your utilities including gas, steam, air and water and set up general condition alarming and pre-event alarms for impending or imminent conditions. Interface with other energy management and SCADA systems through multiple communication channels and protocols like OPC.

Reports

Standard reports provide models of daily electricity usage so you can distribute loads and avoid demand peaks. This enables you to allocate energy consumption and/or costs to individual areas and identify expensive processes that need attention. The historic trending report compiles data from load circuits over a users predefined period. This enables the user to fully utilize the power distribution system and run at near rated tolerances.

Ordering information

Powermanager Software and Device License	Catalog Number
POWERMANAGER BASIC 10 DEVICES	3ZS27110CC300YA0
POWERMANAGER 10 DEVICES with Expert MODE	3ZS27118CC300YA0
POWERMANAGER 20 ADTNL.DEVICES	3ZS27110CC300YD0
POWERMANAGER 50 ADTNL.DEVICES	3ZS27120CC300YD0
POWERMANAGER 100 ADTNL.DEVICES	3ZS27130CC300YD0
POWERMANAGER 200 ADTNL.DEVICES	3ZS27140CC300YD0
POWERMANAGER 500 ADTNL.DEVICES	3ZS27150CC300YD0
POWERMANAGER 1000 ADTNL.DEVICES	3ZS27160CC300YD0
Powermanager Add Ons and Upgrades	Catalog Number
POWERMANAGER OPT PACKAGE EXPERT	3ZS27102CC200YH0
POWERMANAGER OPT PACKAGE CLIENT5	3ZS27103CC000YD0
POWERMANAGER OPT PACKAGE 2 x DISTRIBUTION SYS	3ZS27181CC000YH0
POWERMANAGER OPT PACKAGE 5 x DISTRIBUTION SYS	3ZS27182CC000YH0
POWERMANAGER OPT PACKAGE 10 x DISTRIBUTION SYS	3ZS27183CC000YH0

Contact Siemens for upgrade information

SENTRON Powermanager software, combined with Siemens power meters and low-voltage protective devices, provides a complete energy management solution for your business. It allows you to measure, process, analyze, store and share energy usage and status information across your entire enterprise. It offers control capabilities, comprehensive energy usage and reliability, and detailed reporting that will help you reduce energy related costs.

Benefits

- Visibility and control of power flows
- Exact knowledge of the consumption profile
- Increase of energy efficiency
- Optimization of power supply contracts
- Compliance with contractual terms or regulations
- Allocation of costs to individual cost centers
- Optimization of plant maintenance
- Identification of critical systems conditions

The Powermanager software:

- Is available in a stand-alone or LAN/WAN based configuration that can also exchange information with other supervisory systems like building automation software
- Can utilize any Ethernet or serial based connections
- Is expandable from the basic monitoring application to a fully customized enterprise management system
- Is fully scalable with regard to the connected devices and to the software's function to meet current and future needs
- Ensures the seamless integration of power monitoring devices from the Siemens SENTRON PAC Series Meter, SEM3, and SENTRON WL/VL/3VA circuit breakers as well as other Modbus communicating devices
- Is designed to collect, archive, monitor, display and evaluate any kind of energy related device data
- Provides web based reporting and detailed graphics construction utilities as standard

WinPM.Net Enhanced Web-Enabled Energy Management Software

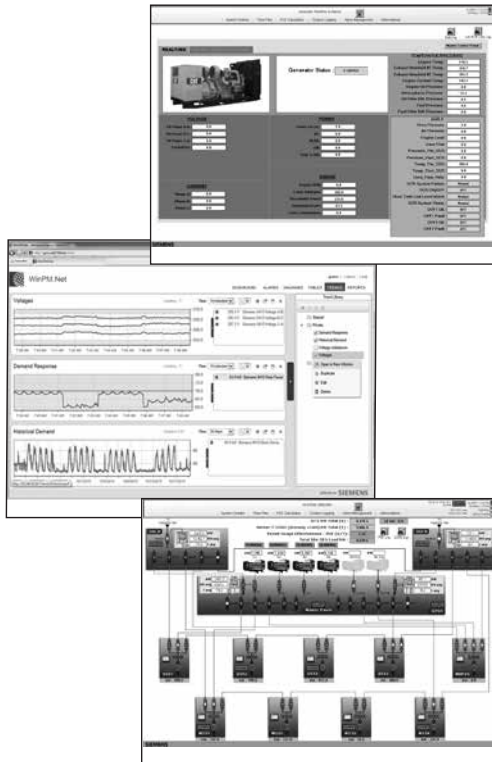

WinPM.net is a complete energy information management solution for your business allowing you to process, analyze, store and share energy usage and power quality data across your entire enterprise. It offers control capabilities, comprehensive power quality and reliability analysis and can help you reduce energy-related costs. WinPM.net allows you to manage intelligent metering and protective devices, analyze data, and decide on new courses of action to help you save money and keep your business up and running.

Its cutting-edge flexibility and compatibility means you can add one piece at a time, at your own pace, while still maintaining your original investments. Interface to your existing systems through industry-standard protocols and choose newer components as they become available.

The WinPM.net software:

- Provides detailed analysis of the power quality and overlays waveforms to correlate phase-to-phase relationships between voltages and currents and cascading failures
- Pinpoints the sources of transients, harmonics, or sags, whether external or internal to your facility, allowing you to decide on the right corrective actions. By monitoring circuits 24 hours a day, you can develop strategies to avoid interruptions
- Provides a comprehensive graphics utility as standard to build and edit any graphical screen whether it is a standard screen or a customized one. These custom screens can display real-time and historical data, alarms, status indications, meter, relay and third party equipment information
- Supports Modbus RTU, Modbus TCP, ION, XML, OPC, FTP, and PQDIF compliant systems, so you can unify your diverse operations into one system. Interface to other energy management software, or include transducers, PLCs, and RTUs in a WinPM.net network. OPC can extract values from other software databases then combine these values with up-to-date readings from WinPM.net to perform real time calculations
- Offers easy, cost effective and fast system expansion. The system grows as your needs grow. Add one piece at a time, at your own pace, within your own budget

Cost allocation and sub-billing

Track energy-related costs by building, feeder, or tool. Match virtually any billing structure and use comprehensive multi-year scheduling and time-of-use activity profiles.

Load studies and asset management

Trend power usage data to take full advantage of your electrical distribution system capacity and avoid over-design. Create usage profiles so you can distribute loads and avoid demand peak.

Demand and power factor control

Eliminate penalties through automated power factor correction, load shedding, or peak shaving.

Equipment monitoring and control

Meter all your utilities including gas, steam, air and water. Set up alarms for pending problems, pre-alarm on impending or imminent conditions. Interface with other energy management and SCADA systems through multiple communication channels and protocols.

Ordering information

Software	Catalogue Number
WinPM.NET V7.0 DVD New (includes 5 meter device licenses, 1 Eng Client, 2 Web Clients, & PQDIF)	3ZS67100CC700BA0
WinPM.NET V7.0 DVD Replacement	3ZS67100CC700BC0
Device License	
WinPM.Net V7.0 9xxx Meter Device License Limit 6 to 50	3ZS68120CC700BA2
WinPM.Net V7.0 9xxx Meter Device License Limit 51 to 100	3ZS68130CC700BA2
WinPM.Net V7.0 9xxx Meter Device License Limit 101 to 1000	3ZS68140CC700BA2
WinPM.Net V7.0 3rd Party device/Modbus/SeaBus Dev. Lic. Limit 1 to 50	3ZS68220CC700BA2
WinPM.Net V7.0 3rd Party device/Modbus/SeaBus Dev. Lic. Limit 51 to 100	3ZS68230CC700BA2
WinPM.Net V7.0 3rd Party device/Modbus/SeaBus Dev. Lic. Limit 101 to 1000	3ZS68240CC700BA2
Options	
WinPM.Net V7.0 Engineering Client License Limit 1 to 50	3ZS67220CC700BA2
WinPM.Net V7.0 Engineering Client License Limit 51 to 100	3ZS67230CC700BA2
WinPM.Net V7.0 Web Client License	3ZS67420CC700BA2
WinPM.Net V7.0 OPC Server License	3ZS67520CC700BA2
WinPM.NetSQL Server 2012 -2 CORE License increment (***Minimum of 4 cores per server is required (2 x 3ZS67312CC700BA0 minimum))	3ZS67308CC700BA0
WinPM.NetSQL Server 2014 -2 CORE License increment (***Minimum of 4 cores per server is required (2 x 3ZS67314CC700BA0 minimum))	3ZS67308CC700BA0
Dashboard solutions and Software upgrade	
Contact your local Siemens Business Developer for ordering information and upgrade	

Application Engineering



Application Engineering capabilities

Provides:

- Power Quality Reliability & Analysis
- Utilities Cost Allocation & Billing
- Utilities Usage Aggregation
- Load Preservation
- Equipment Monitoring
- Facility Monitoring & Automation
- Sequence of Event Recording
- Preventative Maintenance
- Electrical Asset Management

The Siemens Power Distribution Solutions Application Engineering team provide the required experience and knowledge to implement any system regardless of the size or complexity. Siemens Application Engineers are highly skilled professionals who understand how to combine the best PMC software and hardware to create solutions that exceed our customer's expectations.

Key Market Expertise:

- Commercial Construction:
 - New / Retrofit
 - Tenant / Sub Billing
- Critical Power:
 - Data Centers
 - Hospitals
 - JCAHO
- Government:
 - Local, Provincial & Federal Government EPACT projects
 - Universities
 - Airports
- Industrial Applications:
 - Petro - Chem., Cement, Food & Beverage, Waste water, Automotive

PDS Custom Solutions:

- LAN – WAN based solutions using our WinPM.Net web-based software
- Custom power metering logic
- Custom billing, energy usage or load profile reports
- Integration of other utilities like gas, water, steam, air and more
- Custom interactive one-line, elevation or floor plan graphics
- Third party hardware and software Integration
- Extensive alarm configuration and implementation
- Custom data logging and data retrieval.
- Siemens or others plant factory witness testing
- On-site and remote hands-on system training
- Overall PMC project management

Application Engineers Capabilities:

- Communication network topology approval drawings
- Project management plan for the PMC system
- Interface to Siemens APOGEE building management system
- Power monitoring workstations and server configuration
- Final as-built operation and maintenance manuals
- Integrate with Siemens medium-voltage, low-voltage Switchgear & motor control centres
- Integration with Siemens Industrial Automation components & Software WinCC / PCS 7
- System communication troubleshooting
- Site Acceptance Test procedure (SAT), Method of Procedures (MOP), Factory Acceptance Test Procedure (FAT)
- On-site startup & commissioning

Reliable Power Quality

Whether you are designing a fault tolerant mission critical infrastructure or you want to intelligently balance workloads to optimize energy usage and control costs, you need a reliable and industry proven monitoring solution. You will gain a visible look into the actual power consumption to understand the average and peak power utilization, monitor and manage UPS's and power distribution units, or even a complete IT support infrastructure, including generators, environmental systems and detection devices, as well as other components from multiple vendors. A Siemens designed solution using WinPM.Net or Powermanager, coupled with high quality Siemens meters will result in a powerful tool, helping to analyze, identify and correct power issues before they become critical. Instant notification by email or alarm when power quality issues such as sag/swell or voltage disturbance occur.

Flexible

Easily integrate with any vendor's equipment using standard communication protocols to combine critical alerts and real-time data. Monitor and manage critical power devices from a single uninterruptible power system (UPS), an enterprise-wide network of many UPS's and power distribution devices, or a complete IT support infrastructure, including generators, environmental systems and detection devices, and other components from multiple vendors.

Informative

Siemens Power Distribution and Solutions provide an energy monitoring solution that can provide you with the reports and the data you need for your operation. Complete power analysis from the incoming utility power to individual branch circuits.

Services



Advantages to You...

- Technical experts
- Single source supplier
- Available 24/7, 365 days a year
- Reduced total cost of ownership (TCO)
- Avoid unscheduled downtime with preventive maintenance

SIEPRO Service Products

Modular SIEPRO service products enable you to customize a technical service agreement to meet your organization's maintenance needs over the entire life cycle of your installation. Including SIEPRO products in your TSA will provide the following benefits:

- Substantial savings versus "on demand" purchases
- Optimized scaling of your maintenance organization
- Assurance that your installation is operating at maximum performance and availability

Telephone and Internet

Priority support

When you need help right now, choose the support coverage that fits your business:

- 24 hours x 7 days a week
- 8 hours x 5 days a week

Extended support

With extended support, you can request blocks of support hours for specific projects and tasks. We can customize this support service to meet your individual needs.

Remote service

Remote service provides support and diagnostics via data line to save you time and money. Technical support specialists directly access your system for real-time troubleshooting to provide maximum uptime.

Technical account liaison

A technical account liaison provides consulting and guidance on all aspects of support through familiarity with the application, your business goals and processes, and your maintenance and engineering staff.

In addition to a site visit to assess your installation and support requirements, the technical account liaison will conduct monthly reviews with your staff to ensure you are receiving maximum payback on your investment.

Field services

Block of hours

Purchase field service hours in 40 hour increments for preventative, predictive or emergency services.

Embedded engineer

Full-time, on-site support from a certified Siemens professional.

Emergency support

Purchase emergency service hours in 40 hour increments to ensure the fastest possible response time.

Maintenance programs

Packaged maintenance programs available for:

- System performance checks
- Run diagnostics
- Analyze power quality
- Visual inspections of key system components
- Database trim and backup

Training

Operation and maintenance
Siemens training offers a broad range of educational services, providing quality and excellence to the automation industry. Targeted product and system training provides the student with practical, hands-on experience.

Customized on-site training

On-site training is excellent for large groups or when individual, one-on-one instruction is needed. When the trainer visits your facility, product training will be conducted on your specific installation. Classroom lectures, and troubleshooting techniques specific to your installation are covered in detail during the training session.

Software update service

The software update service enables you to take advantage of enhancements to the most current software versions. A site evaluation is conducted to determine necessary upgrade requirements prior to the Software Update Service.

Notes
