

SIEMENS

RUGGEDCOM RX1512

Installation Guide

Preface

Introduction

1

Installing the Device

2

Modules

3

Technical Specifications

4

Dimension Drawings

5

Certification

6

Copyright © 2017 Siemens Canada Ltd

All rights reserved. Dissemination or reproduction of this document, or evaluation and communication of its contents, is not authorized except where expressly permitted. Violations are liable for damages. All rights reserved, particularly for the purposes of patent application or trademark registration.

This document contains proprietary information, which is protected by copyright. All rights are reserved. No part of this document may be photocopied, reproduced or translated to another language without the prior written consent of Siemens Canada Ltd.

» Disclaimer Of Liability

Siemens has verified the contents of this document against the hardware and/or software described. However, deviations between the product and the documentation may exist.

Siemens shall not be liable for any errors or omissions contained herein or for consequential damages in connection with the furnishing, performance, or use of this material.

The information given in this document is reviewed regularly and any necessary corrections will be included in subsequent editions. We appreciate any suggested improvements. We reserve the right to make technical improvements without notice.

» Registered Trademarks

RUGGEDCOM™ and ROS™ are trademarks of Siemens Canada Ltd.

Linux® is the registered trademark of Linus Torvalds in the United States and other countries.

The registered trademark Linux® is used pursuant to a sublicense from LMI, the exclusive licensee of Linus Torvalds, owner of the mark on a world-wide basis.

Other designations in this manual might be trademarks whose use by third parties for their own purposes would infringe the rights of the owner.

» Security Information

Siemens provides products and solutions with industrial security functions that support the secure operation of plants, machines, equipment and/or networks. They are important components in a holistic industrial security concept. With this in mind, Siemens' products and solutions undergo continuous development. Siemens recommends strongly that you regularly check for product updates.

For the secure operation of Siemens products and solutions, it is necessary to take suitable preventive action (e.g. cell protection concept) and integrate each component into a holistic, state-of-the-art industrial security concept. Third-party products that may be in use should also be considered. For more information about industrial security, visit <http://www.siemens.com/industrialsecurity>.

To stay informed about product updates as they occur, sign up for a product-specific newsletter. For more information, visit <http://support.automation.siemens.com>.

» Warranty

Siemens warrants this product for a period of five (5) years from the date of purchase, conditional upon the return to factory for maintenance during the warranty term. This product contains no user-serviceable parts. Attempted service by unauthorized personnel shall render all warranties null and void. The warranties set forth in this article are exclusive and are in lieu of all other warranties, performance guarantees and conditions whether written or oral, statutory, express or implied (including all warranties and conditions of merchantability and fitness for a particular purpose, and all warranties and conditions arising from course of dealing or usage or trade). Correction of nonconformities in the manner and for the period of time provided above shall constitute the Seller's sole liability and the Customer's exclusive remedy for defective or nonconforming goods or services whether claims of the Customer are based in contract (including fundamental breach), in tort (including negligence and strict liability) or otherwise.

For warranty details, visit www.siemens.com/ruggedcom or contact a Siemens customer service representative.

» Contacting Siemens

Address
Siemens Canada Ltd

Telephone
Toll-free: 1 888 264 0006

E-mail
ruggedcom.info.i-ia@siemens.com

Industry Sector
300 Applewood Crescent
Concord, Ontario
Canada, L4K 5C7

Tel: +1 905 856 5288
Fax: +1 905 856 1995

Web
www.siemens.com/ruggedcom

Table of Contents

Preface	vii
Alerts	vii
Related Documents	viii
Accessing Documentation	viii
Training	viii
Customer Support	viii
 Chapter 1	
Introduction	1
1.1 Feature Highlights	1
1.2 Description	1
 Chapter 2	
Installing the Device	3
2.1 General Procedure	4
2.2 Required Tools and Materials	4
2.3 Cabling Recommendations	5
2.3.1 Protection On Twisted-Pair Data Ports	5
2.3.2 Gigabit Ethernet 1000Base-TX Cabling Recommendations	5
2.4 Mounting the Device	6
2.4.1 Mounting the Device on a DIN Rail	6
2.4.2 Mounting the Device to a Panel	7
2.5 Connecting the Failsafe Alarm Relay	7
2.6 Connecting Power	8
2.6.1 Testing Dielectric Strength	10
2.7 Connecting to the Device	10
2.8 Configuring the Device	12
 Chapter 3	
Modules	13
3.1 Available Modules	14
3.2 Installing/Removing Line Modules	20
 Chapter 4	
Technical Specifications	23
4.1 Power Supply Specifications	23

4.2	Fail-safe Relay Specifications	23
4.3	Operating Environment	24
4.4	Mechanical Specifications	24
Chapter 5		
	Dimension Drawings	25
Chapter 6		
	Certification	29
6.1	Approvals	29
6.1.1	TÜV SÜD	29
6.1.2	European Union (EU)	30
6.1.3	FCC	31
6.1.4	FDA/CDRH	31
6.1.5	ISED	31
6.1.6	RoHS	31
6.1.7	Other Approvals	32
6.2	EMC and Environmental Type Tests	32

Preface

This guide describes the RUGGEDCOM RUGGEDCOM RX1512. It describes the major features of the device, installation, commissioning and important technical specifications.

It is intended for use by network technical support personnel who are responsible for the installation, commissioning and maintenance of the device. It is also recommended for use by network and system planners, system programmers, and line technicians.

CONTENTS

- [“ Alerts ”](#)
- [“Related Documents”](#)
- [“Accessing Documentation”](#)
- [“Training”](#)
- [“Customer Support”](#)

Alerts

The following types of alerts are used when necessary to highlight important information.



DANGER!

DANGER alerts describe imminently hazardous situations that, if not avoided, will result in death or serious injury.



WARNING!

WARNING alerts describe hazardous situations that, if not avoided, may result in serious injury and/or equipment damage.



CAUTION!

CAUTION alerts describe hazardous situations that, if not avoided, may result in equipment damage.



IMPORTANT!

IMPORTANT alerts provide important information that should be known before performing a procedure or step, or using a feature.



NOTE

NOTE alerts provide additional information, such as facts, tips and details.

Related Documents

Other documents that may be of interest include:

- *RUGGEDCOM ROX II User Guide for the RUGGEDCOM RX1512*
- *RUGGEDCOM RX1500 Series Modules Catalog*

Accessing Documentation

The latest user documentation for RUGGEDCOM RX1512 is available online at www.siemens.com/ruggedcom. To request or inquire about a user document, contact Siemens Customer Support.

Training

Siemens offers a wide range of educational services ranging from in-house training of standard courses on networking, Ethernet switches and routers, to on-site customized courses tailored to the customer's needs, experience and application.

Siemens' Educational Services team thrives on providing our customers with the essential practical skills to make sure users have the right knowledge and expertise to understand the various technologies associated with critical communications network infrastructure technologies.

Siemens' unique mix of IT/Telecommunications expertise combined with domain knowledge in the utility, transportation and industrial markets, allows Siemens to provide training specific to the customer's application.

For more information about training services and course availability, visit www.siemens.com/ruggedcom or contact a Siemens Sales representative.

Customer Support

Customer support is available 24 hours, 7 days a week for all Siemens customers. For technical support or general information, contact Siemens Customer Support through any of the following methods:



Online

Visit <http://www.siemens.com/automation/support-request> to submit a Support Request (SR) or check on the status of an existing SR.

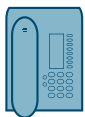

Telephone

Call a local hotline center to submit a Support Request (SR). To locate a local hotline center, visit <http://www.automation.siemens.com/mcms/aspa-dben/automation-technology/Pages/default.aspx>.



Mobile App

Install the Industry Online Support app by Siemens AG on any Android, Apple iOS or Windows mobile device and be able to:

- Access Siemens' extensive library of support documentation, including FAQs and manuals
- Submit SRs or check on the status of an existing SR
- Contact a local Siemens representative from Sales, Technical Support, Training, etc.
- Ask questions or share knowledge with fellow Siemens customers and the support community

1 Introduction

The RUGGEDCOM RUGGEDCOM RX1512 is a cost-efficient, rugged Layer 3 switch and router. The RUGGEDCOM RX1512's modular and field replaceable platform can be equipped with WAN, serial, and Ethernet options, making it ideally suited for electric power utilities, the industrial plant floor, and traffic control systems. The appliance's compact form factor makes it ideal for pole mount applications or installation in restricted spaces.

The RUGGEDCOM RX1512 is designed to provide a high level of immunity to electromagnetic interference (EMI) and heavy electrical surges typical of the harsh environments found in many industrial applications. An operating temperature range of -40 to 85 °C (-40 to 185 °F) allows the RUGGEDCOM RX1512 to be placed in almost any location.

CONTENTS

- [Section 1.1, "Feature Highlights"](#)
- [Section 1.2, "Description"](#)

Section 1.1

Feature Highlights

Reliability in Harsh Environments

- Immunity to EMI and high voltage electrical transients
- -40 to 85 °C (-40 to 185 °F) operating temperature (no fans)
- Failsafe output relay for critical failure or error alarming

Universal Power Supply Options

- Fully integrated power supply (no external adapter)
- Input voltage range: 11-72 VDC
- CSA/UL 60950-1 safety approved to 85 °C (185 °F)

Physical Ports

- Field replaceable line modules
- Up to 12 100Base-FX ports
- Up to 12 10/100Base-TX ports
- Up to 6 10Base-FL/100Base-SX ports
- Up to 4 Gigabit Ethernet ports
- Up to 12 serial ports
- Up to 4 T1/E1 RJ48C ports or 2 E1 BNC ports
- Up to 2 DDS (Digital Data Services) ports
- Up to 8 active cellular data interfaces

Section 1.2

Description

The RUGGEDCOM RX1512 features various ports, controls and indicator LEDs on the front panel for connecting, configuring and troubleshooting the device.

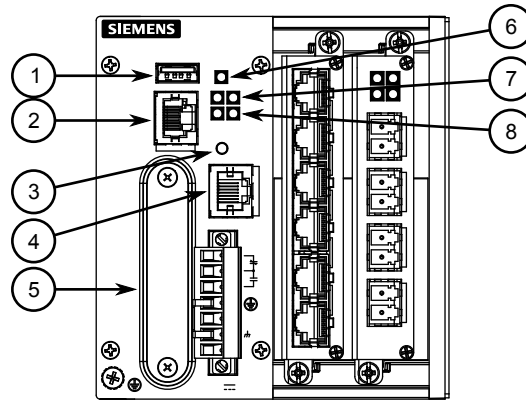

Figure 1: RUGGEDCOM RX1512

1. Utility USB Port 2. RS232 Serial Console Port (RJ45) 3. Lamp Test/Alarm Cut-Off (LT/ACO) Button 4. Management Port 5. Compact Flash Card Port 6. Alarm Indicator LED 7. Power Status LEDs 8. Port Status LEDs

Management Port	This 10/100Base-T Ethernet port is used for system management that is out-of-band from the switch fabric.
RS-232 Serial Console Port	The serial console port is for interfacing directly with the device and accessing initial management functions. For information about connecting to the device via the serial console port, refer to Section 2.7, "Connecting to the Device" .
Utility USB Port	Use the USB port to upgrade the ROX II software or install files, such as configuration files and feature key files. For more information, refer to the <i>RUGGEDCOM ROX II User Guide</i> for the RUGGEDCOM RX1512.
Lamp Test/Alarm Cut-Off (LT/ACO) Button	This button performs two functions: <ul style="list-style-type: none"> • Press and hold this button to test all indicator LEDs • Press and release this button to acknowledge an active alarm
Power Status LEDs	Indicates the status of the power modules. <ul style="list-style-type: none"> • I = The power module is receiving power • O = The power module is supplying power
Port Status LEDs	Indicates when ports are active. <ul style="list-style-type: none"> • Green = OK • Orange = Warning alert • Red = Configuration error
Alarm Indicator LED	Indicates when an alarm condition exists. <ul style="list-style-type: none"> • Green = Alarms cleared/acknowledged • Red = Alarm
Compact Flash Card Port	Houses the 1 GB compact flash card that contains active and backup installations of RUGGEDCOM ROX II, along with the configuration database and other system data.



CAUTION!

Configuration hazard – risk of data corruption/loss. Do not open the compact flash card port, unless specifically instructed to by a Siemens Customer Support representative. The warranty will be void otherwise. Removing the compact flash card improperly can corrupt configuration data.

2 Installing the Device

This chapter describes how to install the device, including mounting the device, connecting power, and connecting the device to the network.



DANGER!

Electrocution hazard – risk of serious personal injury and/or damage to equipment. Before performing any maintenance tasks, make sure all power to the device has been disconnected and wait approximately two minutes for any remaining energy to dissipate.



WARNING!

*Radiation hazard – risk of serious personal injury. This product contains a laser system and is classified as a **CLASS 1 LASER PRODUCT**. Use of controls or adjustments or performance of procedures other than those specified herein may result in hazardous radiation exposure.*



WARNING!

Radiation hazard – risk of Radio Frequency (RF) exposure. This device is compliant with the requirements set forth in FCC 47 CFR, section 1.1307, addressing Radio Frequency (RF) exposure from radio frequency base stations, as defined in FCC OET Bulletin 65 [http://transition.fcc.gov/Bureaus/Engineering_Technology/Documents/bulletins/oet65/oet65.pdf]. The emitted radiation should be as little as possible. To achieve minimum RF exposure, install the device when it is configured not to transmit and set it to operational mode remotely, rather than having a technician enable transmission on-site. For maintenance of the base station, or other operations which require RF exposure, the exposure should be minimized in time and according to the regulations set forth by the country of installation or the Federal Communications Commission (FCC).



IMPORTANT!

This product contains no user-serviceable parts. Attempted service by unauthorized personnel shall render all warranties null and void.

Changes or modifications not expressly approved by Siemens Canada Ltd could invalidate specifications, test results, and agency approvals, and void the user's authority to operate the equipment.



IMPORTANT!

*This product should be installed in a **restricted access location** where access can only be gained by authorized personnel who have been informed of the restrictions and any precautions that must be taken. Access must only be possible through the use of a tool, lock and key, or other means of security, and controlled by the authority responsible for the location.*

CONTENTS

- [Section 2.1, "General Procedure"](#)
- [Section 2.2, "Required Tools and Materials"](#)
- [Section 2.3, "Cabling Recommendations"](#)

- [Section 2.4, "Mounting the Device"](#)
- [Section 2.5, "Connecting the Failsafe Alarm Relay"](#)
- [Section 2.6, "Connecting Power"](#)
- [Section 2.7, "Connecting to the Device"](#)
- [Section 2.8, "Configuring the Device"](#)

Section 2.1

General Procedure

The general procedure for installing the device is as follows:

1. Review the relevant certification information for any regulatory requirements. For more information, refer to [Section 6.1, "Approvals"](#).
2. Review the *RUGGEDCOM RX1500 Series Modules Catalog* for special installation or regulatory requirements related to the modules installed in the device. In the case of cellular modem line modules, this includes antenna installation and regulatory requirements.
3. Mount the device.
4. Connect the failsafe alarm relay.
5. Connect power to the device and ground the device to safety Earth.
6. Connect the device to the network.
7. Configure the device.

Section 2.2

Required Tools and Materials

The following tools and materials are required to install the RUGGEDCOM RX1512:

Tools/Materials	Purpose
AC/DC power cord (16 AWG)	For connecting power to the device.
Lightning protector	For protecting the device from harmful electrical strikes.
Shielded coaxial cables	For connecting the device to antennas and an Ethernet network.
SIM Card(s) provided by the network carrier	For accessing a network carrier's cellular network. Required only if a cellular modem module is equipped.
Flathead screwdriver	For mounting the device to a DIN rail.
Phillips screwdriver	For mounting the device to a panel.
4 x #6-32 screws	For mounting the device to a panel.
Braided or equivalent ground wire	For grounding the device to safety Earth.

Section 2.3

Cabling Recommendations

Siemens recommends using SIMATIC NET industrial Ethernet shielded cables for all Ethernet ports.

CONTENTS

- [Section 2.3.1, "Protection On Twisted-Pair Data Ports"](#)
- [Section 2.3.2, "Gigabit Ethernet 1000Base-TX Cabling Recommendations"](#)

Section 2.3.1

Protection On Twisted-Pair Data Ports

All copper Ethernet ports on RUGGEDCOM products include transient suppression circuitry to protect against damage from electrical transients and conform with IEC 61850-3 and IEEE 1613 Class 1 standards. This means that during a transient electrical event, communications errors or interruptions may occur, but recovery is automatic.

Siemens also does not recommend using copper Ethernet ports to interface with devices in the field across distances that could produce high levels of ground potential rise (i.e. greater than 2500 V), during line-to-ground fault conditions.

Section 2.3.2

Gigabit Ethernet 1000Base-TX Cabling Recommendations

The IEEE 802.3ab Gigabit Ethernet standard defines 1000 Mbit/s Ethernet communications over distances of up to 100 m (328 ft) using all 4 pairs in category 5 (or higher) balanced, unshielded twisted-pair cabling. For wiring guidelines, system designers and integrators should refer to the Telecommunications Industry Association (TIA) TIA/EIA-568-A wiring standard that characterizes minimum cabling performance specifications required for proper Gigabit Ethernet operation. For reliable, error-free data communication, new and pre-existing communication paths should be verified for TIA/EIA-568-A compliance.

The following table summarizes the relevant cabling standards:

Cabling Category	1000Base-TX Compliant	Required Action
< 5	No	New wiring infrastructure required.
5	Yes	Verify TIA/EIA-568-A compliance.
5e	Yes	No action required. New installations should be designed with Category 5e or higher.
6	Yes	No action required.
> 6	Yes	Connector and wiring standards to be determined.

Follow these recommendations for copper data cabling in high electrical noise environments:

- Data cable lengths should be as short as possible, preferably 3 m (10 ft) in length. Copper data cables should not be used for inter-building communications.
- Power and data cables should not be run in parallel for long distances, and should be installed in separate conduits. Power and data cables should intersect at 90° angles when necessary to reduce inductive coupling.

Section 2.4

Mounting the Device

The RUGGEDCOM RX1512 is designed for maximum mounting and display flexibility. It can be equipped with connectors that allow it to be installed in a 35 mm (1.4 in) DIN rail, or directly on a panel.



IMPORTANT!

Heat generated by the device is channeled outwards to the enclosure. As such, it is recommended that 2.5 cm (1 in) of space be maintained on all open sides of the device to allow for some convective airflow.

Forced airflow is not required. However, any increase in airflow will result in a reduction of ambient temperature and improve the long-term reliability of all equipment mounted in the rack space.



NOTE

For detailed dimensions of the device with either DIN rail or panel hardware installed, refer to [Chapter 5, Dimension Drawings](#).

CONTENTS

- [Section 2.4.1, "Mounting the Device on a DIN Rail"](#)
- [Section 2.4.2, "Mounting the Device to a Panel"](#)

Section 2.4.1

Mounting the Device on a DIN Rail

For DIN rail installations, the RUGGEDCOM RX1512 can be equipped with panel/DIN rail adapters pre-installed on each side of the chassis. The adapters allow the device to be slid onto a standard 35 mm (1.4 in) DIN rail.

To mount the device to a DIN rail, do the following:

1. Align the adapters with the DIN rails and slide the device into place.

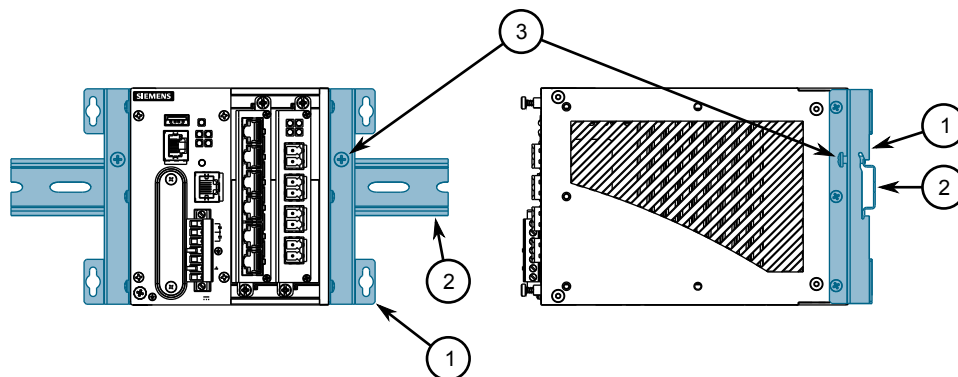

Figure 2: DIN Rail Mounting

1. Panel/DIN Rail Adapter 2. DIN Rail 3. Screw

2. Install one of the supplied screws on either side of the device to secure the adapters to the DIN rails.

Section 2.4.2

Mounting the Device to a Panel

For panel installations, the RUGGEDCOM RX1512 can be equipped with panel/DIN rail adapters pre-installed on each side of the chassis. The adapters allow the device to be attached to a panel using screws.

To mount the device to a panel, do the following:

1. Place the device against the panel and mark the mounting holes on the panel.

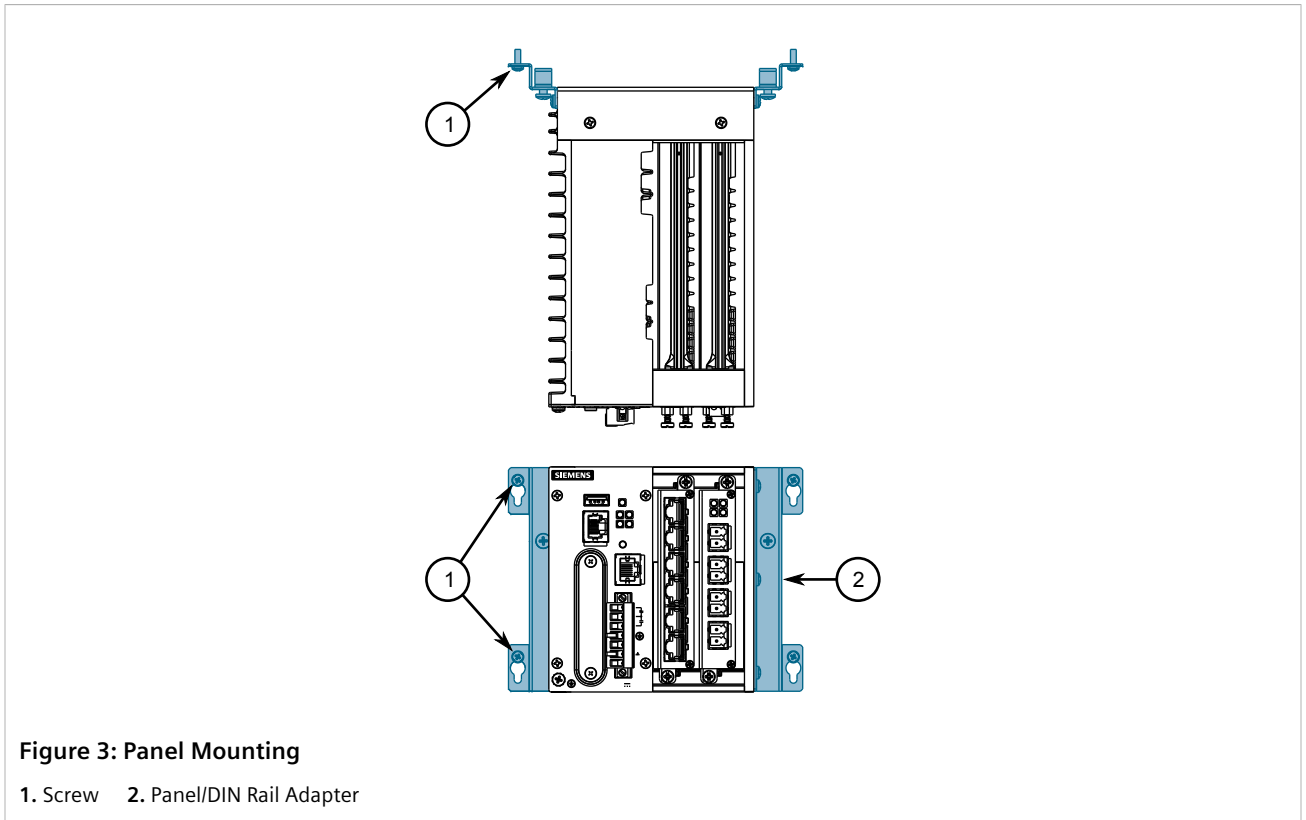

2. Prepare the mounting holes
3. Align the device with the mounting holes and secure it to the panel.

Section 2.5

Connecting the Failsafe Alarm Relay

The failsafe relay can be configured to latch based on alarm conditions. The NO (Normally Open) contact is closed when the unit is powered and there are no active alarms. If the device is not powered or if an active alarm is configured, the relay opens the NO contact and closes the NC (Normally Closed) contact.



NOTE

Control of the failsafe relay output is configurable through ROX II. One common application for this relay is to signal an alarm if a power failure occurs. For more information, refer to the ROX II User Guide for the RUGGEDCOM RX1512.

The following shows the proper relay connections.

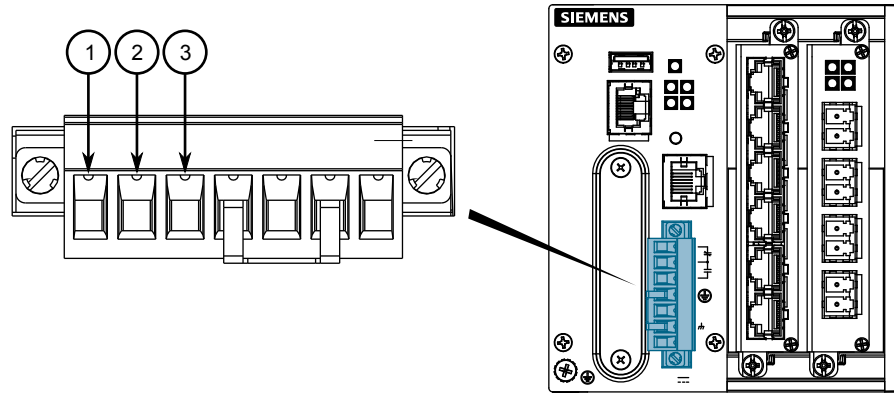

Figure 4: Failsafe Alarm Relay Wiring

1. Normally Closed 2. Common 3. Normally Open

Section 2.6

Connecting Power

To connect a DC power supply to the device, do the following:



CAUTION!

Electrical hazard – risk of damage to equipment. Do not connect AC power cables to a 12, 24 or 48 VDC power supply terminal block. Damage to the power supply may occur.



IMPORTANT!

When connecting the device to a DC power source, make sure the source provides only positive voltage.



IMPORTANT!

- Use only #16 gage copper wiring when connecting terminal blocks.
- It is recommended to provide a 20 A circuit breaker for the power supply.
- Equipment must be installed according to applicable local wiring codes and standards.
- Make sure the DC power source provides only positive voltage.



CAUTION!

Electrical hazard – risk of damage to equipment. In normal operation, the jumper between the chassis ground and surge ground terminals must be installed for proper operation. Damage to the device may occur otherwise. Removing the jumper may also void the warranty.



NOTE

For information about how to safely test the dielectric strength of the device, refer to [Section 2.6.1, "Testing Dielectric Strength"](#).

1. Connect the power supply terminal block to the device.

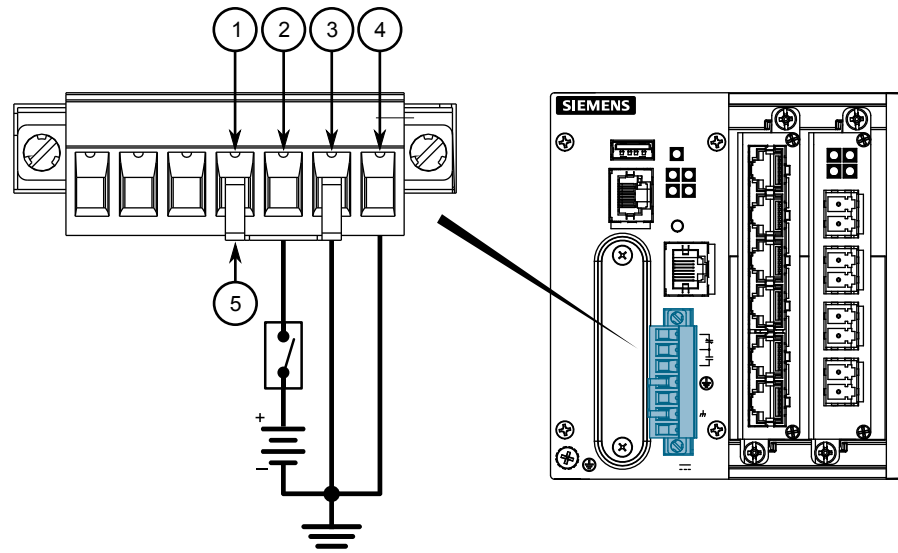

Figure 5: DC Terminal Block Wiring

1. Surge Ground Terminal 2. Positive (+) Terminal 3. Negative (-) Terminal 4. Chassis Ground Terminal 5. Jumper

2. Connect the positive wire from the power source to the positive (+) terminal on the terminal block.
3. Connect the negative wire from the power source to the negative (-) terminal on the terminal block.
4. Using a braided wire or other appropriate grounding wire, connect the chassis ground terminal to the chassis ground connection. The surge ground terminal is used as the ground conductor for all surge and transient suppression circuitry internal to the unit.
5. Using a #10 ring lug and #10-32 screw, secure the ground terminal on the power source to the chassis ground terminal on the device. Make sure the lug is tightened to 3.4 N·m (30 lbf·in).

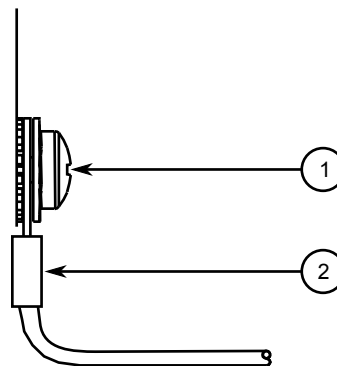

Figure 6: Chassis Ground Connection

1. #10-32 Screw 2. #10 Ring Lug

6. Install the safety cover over the terminal block. **This is mandatory for 48 VDC power supplies.**

CONTENTS

- [Section 2.6.1, "Testing Dielectric Strength"](#)

Section 2.6.1

Testing Dielectric Strength

Before performing any dielectric strength or HIPOT (High Potential) testing on the RUGGEDCOM RX1512 in the field, do the following:



IMPORTANT!

In normal operation, the jumper between the chassis ground and surge ground terminals must be installed for proper operation. Removing the jumper may void the warranty.



CAUTION!

Electrical hazard – risk of damage to equipment. Before testing the dielectric strength (HIPOT), remove the metal jumper. Damage to equipment may occur.

1. Remove the metal jumper that connects surge ground terminal and the chassis ground terminal. This metal jumper connects transient suppression circuitry to chassis ground and must be removed in order to avoid damage to transient suppression circuitry during testing.

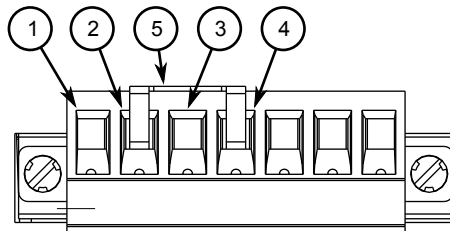

Figure 7: Jumper

1. Negative (-) Terminal 2. Chassis Ground Terminal 3. Positive (+) Terminal 4. Surge Ground Terminal 5. Jumper

2. Connect one terminal from the HIPOT tester to the positive terminal and the negative terminal. Connect the second terminal of the HIPOT tester to chassis ground terminal. Do not connect the HIPOT tester to surge ground terminal.
3. Following the test, install the metal jumper between the surge ground terminal and the chassis ground terminal.

Section 2.7

Connecting to the Device

The following describes the various methods for accessing the ROX II console and Web interfaces on the device. For more detailed instructions, refer to the *RUGGEDCOM ROX II User Guide* for the RUGGEDCOM RX1512.

Serial Console and Management Ports

Connect a workstation directly to the serial console or management ports to access the boot-time control and ROX II interfaces. The serial console port provides access to ROX II's console interface, while the management port provides access to ROX II's console and Web interfaces.



IMPORTANT!

The serial console and management (MGMT) ports are intended to be used only as temporary connections during initial configuration or troubleshooting.

Connection to the console port is made using an RJ-45-to-DB9 console cable. The following is the pin-out for the console port:

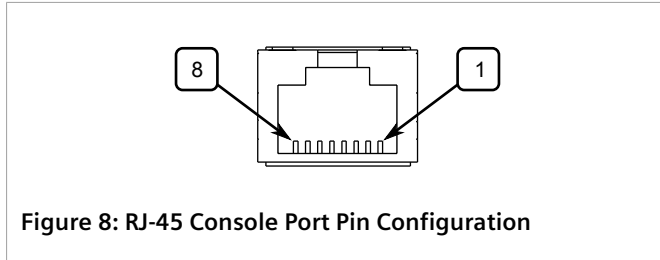

Pin		Name	Description
RJ-45 Male	DB9 Female		
1	6	DSR ^a	Data Set Ready
2	1	Reserved (Do Not Connect)	
3	4	DTR ^a	Data Terminal Ready
4	5	GND	Signal Ground
5	2	RxD	Receive Data (to DTE)
6	3	TxD	Transmit Data (from DTE)
7	8	CTS ^b	Clear to Send
8	7	RTS ^b	Read to Send
	9	RI ^c	Ring Indicator

^a The DSR, DCD and DTR pins are connected together internally.

^b The CTS and RTS pins are connected together internally.

^c RI is not connected.

For information about how to connect to the device via the serial console port, refer to the *RUGGEDCOM ROX II CLI User Guide* for the RUGGEDCOM RX1512.

For information about how to connect to the device via the management port, refer to either the *RUGGEDCOM ROX II Web Interface User Guide* or the *RUGGEDCOM ROX II CLI User Guide* for the RUGGEDCOM RX1512.

The management port is a 10/100Base-TX copper Ethernet port with an RJ-45 connector. The following is the pin-out for the management port:

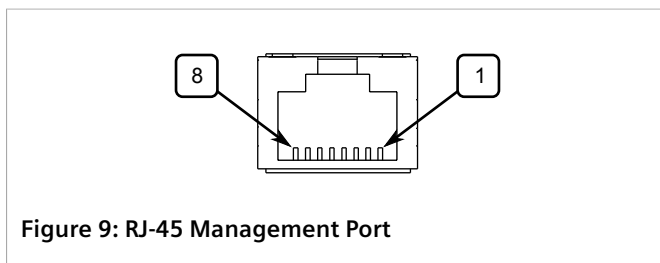

Pin	Name	Description
1	RX+	Receive Data+
2	RX-	Receive Data-
3	TX+	Transmit Data+
4	Reserved (Do Not Connect)	
5	Reserved (Do Not Connect)	
6	TX-	Transmit Data-
7	Reserved (Do Not Connect)	

Pin	Name	Description
8		Reserved (Do Not Connect)

» Communication Ports

Connect any of the available Ethernet ports on the device to a management switch and access the ROX II console and Web interfaces via the device's IP address. The factory default IP address for the RUGGEDCOM RX1512 is <https://192.168.0.2>.

For more information about available ports, refer to [Chapter 3, Modules](#).

Section 2.8

Configuring the Device

Once the device is installed and connected to the network, it must be configured. All configuration management is done via the RUGGEDCOM ROX II interface. For more information about configuring the device, refer to the *RUGGEDCOM ROX II User Guide* associated with the installed software release.

3 Modules

The RUGGEDCOM RX1512 features slots for up to two field-replaceable line modules, which can be used to expand and customize the capabilities of the device to suit specific applications. A variety of modules are available, each featuring a specific type of communication port: copper Ethernet, fiber optic Ethernet, SFP, WAN, cellular modem and DDS. The RUGGEDCOM APE (Application Processing Engine) line module, a utility-grade computing platform for running third-party applications directly from within the RUGGEDCOM RX1512, is also available.

Modules can be installed in any one of the available slots in the device chassis.

Use the RUGGEDCOM ROX II software to determine which ports are equipped on the device. For more information, refer to the *RUGGEDCOM ROX II User Guide* for the device.



NOTE

Only one T1/E1 WAN module or up to two DDS modules are supported.

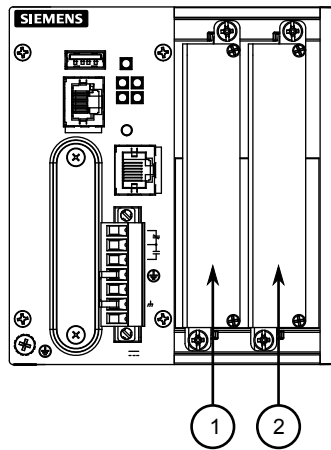

Figure 10: Available Chassis Slots

1. Slot 1 2. Slot 2

CONTENTS

- [Section 3.1, "Available Modules"](#)

• Section 3.2, "Installing/Removing Line Modules"

Section 3.1

Available Modules

The following is a list of all power and line modules available for use in the RUGGEDCOM RX1512. For more information about individual modules, refer to the [RUGGEDCOM RX1500 Series Modules Catalog](https://support.industry.siemens.com/cs/ca/en/view/109747072) [https://support.industry.siemens.com/cs/ca/en/view/109747072].

» Copper Ethernet Modules

RUGGEDCOM RX1500PN LM CG01

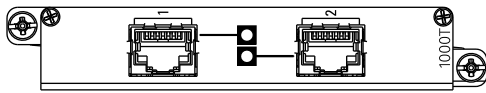

Specifications

Ports: 2
Speed: 10/100/1000Base-TX
Port Type: RJ45
Distance: 100 m (328 ft)

Article Numbers

6GK60150AL200FC0 (Standard)
6GK60150AL200FC1 (Conformal Coated)

RUGGEDCOM RX1500PN M12 CG03

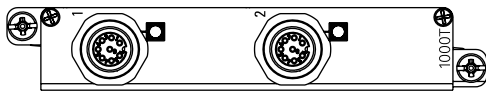

Specifications

Ports: 2
Speed: 10/100/1000Base-TX
Port Type: M12 (8-Pin, A-Coded)
Distance: 100 m (328 ft)

Article Numbers

6GK60150AL200PB0 (Standard)
6GK60150AL200PB1 (Conformal Coated)

RUGGEDCOM RX1500PN M12 CG03B

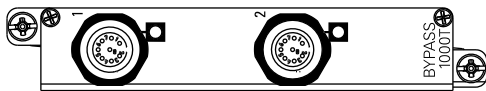

Specifications

Ports: 2
Speed: 10/100/1000Base-TX
Port Type: M12 (8-Pin, A-Coded, Controlled Bypass)
Distance: 100 m (328 ft)

Article Numbers

6GK60150AL200PE0 (Standard)
6GK60150AL200PE1 (Conformal Coated)

RUGGEDCOM RX1500PN M12 X CG04

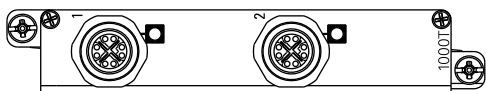

Specifications

Ports: 2
Speed: 10/100/1000Base-TX
Port Type: M12 (8-pin, X-Coded)
Distance: 100 m (328 ft)

Article Numbers

6GK60150AL200PH0 (Standard)
6GK60150AL200PH1 (Conformal Coated)

RUGGEDCOM RX1500PN M12 X CG04B



Specifications

Ports: 2
Speed: 10/100/1000Base-TX
Port Type: M12 (8-pin, X-Coded, Controlled Bypass)
Distance: 100 m (328 ft)

Article Numbers

6GK60150AL200PJ0 (Standard)
6GK60150AL200PJ0 (Conformal Coated)

RUGGEDCOM RX1500PN M12 4TX03

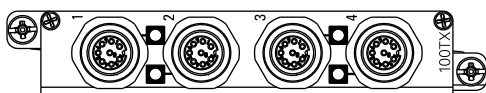

Specifications

Ports: 4
Speed: 10/100/1000Base-TX
Port Type: M12 (4-Pin, A-Coded)
Distance: 100 m (328 ft)

Article Numbers

6GK60150AL200PC0 (Standard)
6GK60150AL200PC1 (Conformal Coated)

RUGGEDCOM RX1500PN M12 4TX03B

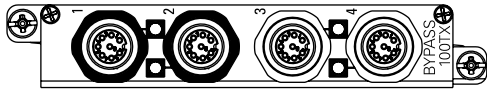

Specifications

Ports: 4
Speed: 10/100/1000Base-TX
Port Type: M12 (8-Pin, A-Coded, Controlled Bypass)
Distance: 100 m (328 ft)

Article Numbers

6GK60150AL200PF0 (Standard)
6GK60150AL200PF1 (Conformal Coated)

RUGGEDCOM RX1500PN M12 4TX04

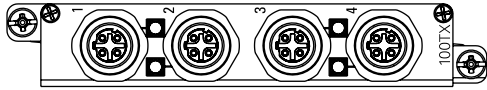

Specifications

Ports: 4
Speed: 10/100/1000Base-TX
Port Type: M12 (4-Pin, D-Coded)
Distance: 100 m (328 ft)

Article Numbers

6GK60150AL200PD0 (Standard)
6GK60150AL200PD1 (Conformal Coated)

RUGGEDCOM RX1500PN M12 4TX04B

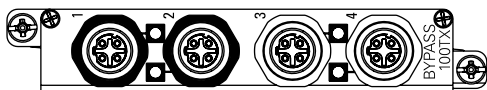

Specifications

Ports: 4
Speed: 10/100/1000Base-TX
Port Type: M12 (4-Pin, A-Coded, Controlled Bypass)
Distance: 100 m (328 ft)

Article Numbers

6GK60150AL200PG0 (Standard)
6GK60150AL200PG1 (Conformal Coated)

RUGGEDCOM RX1500PN LM 6TX01

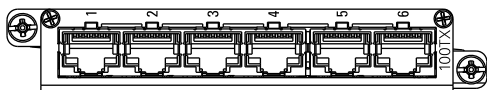

Specifications

Ports: 6
Speed: 10/100Base-TX
Port Type: RJ45
Distance: 100 m (328 ft)

Article Numbers

6GK60150AL200NB0 (Standard)
6GK60150AL200NB1 (Conformal Coated)

» **Fiber Optic Ethernet Modules**

RUGGEDCOM RX1500PN LM 4FX11

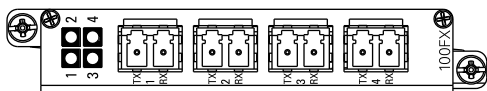

Specifications

Mode: MM
Speed: 100Base-FX
Wavelength: 1300 nm
Ports: 4
Port Type: LC
Distance: 2 km (1.2 mi)

Article Numbers

6GK60150AL200BC0 (Standard)
6GK60150AL200BC1 (Conformal Coated)

RUGGEDCOM RX1500PN LM FL01

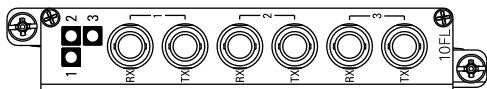

Specifications

Mode: MM
Speed: 10Base-FL/100Base-SX
Wavelength: 820 nm
Ports: 3
Port Type: ST
Distance: 2 km (1.2 mi)

Article Numbers

6GK60150AL200BD0 (Standard)
6GK60150AL200BD1 (Conformal Coated)

RUGGEDCOM RX1500PN LM FG03

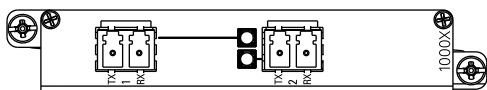

Specifications

Mode: SM
Speed: 1000Base-LX
Wavelength: 820 nm
Ports: 4
Port Type: LC

Article Numbers

6GK60150AL200EC0 (Standard)
6GK60150AL200EC1 (Conformal Coated)

Distance: 10 km (6.2 mi)

» SFP Transceiver Modules

RUGGEDCOM RX1500PN LM FG50

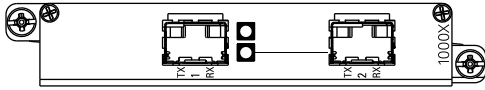

Specifications

Sockets: 2

Article Numbers

6GK60150AL200JB0 (Standard)
6GK60150AL200JB1 (Conformal Coated)

RUGGEDCOM RX1500PN LM FX50

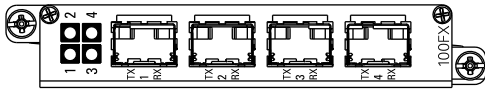

Specifications

Sockets: 4

Article Numbers

6GK60150AL200JC0 (Standard)
6GK60150AL200JC1 (Conformal Coated)

RUGGEDCOM RX1500PN LM 6FX50

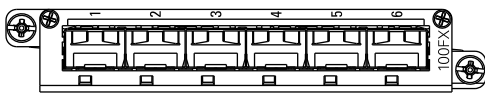

Specifications

Sockets: 6

Article Numbers

6GK60150AL200JD0 (Standard)
6GK60150AL200JD1 (Conformal Coated)

» WAN Modules



NOTE

Only one T1/E1 WAN module or up to two DDS modules are supported.

RUGGEDCOM RX1500PN LM S01

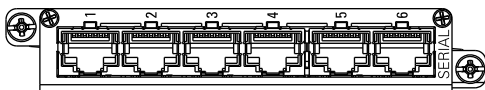

Specifications

Speed: RS232/RS422/RS485

Ports: 6

Port Type: RJ45

Article Numbers

6GK60150AL200KB0 (Standard)
6GK60150AL200KB1 (Conformal Coated)

RUGGEDCOM RX1500PN LM TC1

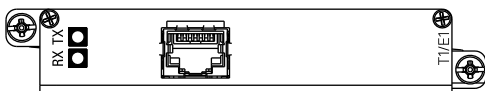

Specifications

Interface: T1/E1

Ports: 1

Port Type: RJ48C

Article Numbers

6GK60150AL200MB0 (Standard)
6GK60150AL200MB1 (Conformal Coated)

RUGGEDCOM RX1500PN LM TC2

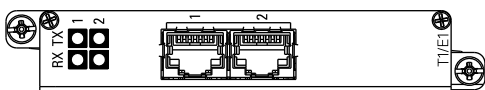

Specifications

Interface: T1/E1

Ports: 2

Port Type: RJ48C

Article Numbers

6GK60150AL200MC0 (Standard)
6GK60150AL200MC1 (Conformal Coated)

RUGGEDCOM RX1500PN LM TC4

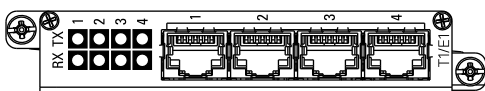

Specifications

Interface: T1/E1

Ports: 4

Port Type: RJ48C

Article Numbers

6GK60150AL200MD0 (Standard)
6GK60150AL200MD1 (Conformal Coated)

RUGGEDCOM RX1500PN LM E02

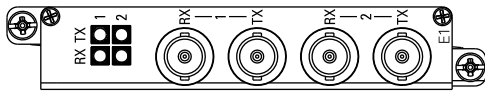

Specifications

Interface: E1
Ports: 4
Port Type: BNC (75 Ω)

Article Numbers

6GK60150AL200HCO (Standard)
6GK60150AL200HC1 (Conformal Coated)

RUGGEDCOM RX1500PN LM D02



Specifications

Speed: 56 kbps (Master/Slave) or 64 kbps (Slave)
Ports: 1
Port Type: RJ48S

Article Numbers

6GK60150AL200LB0 (Standard)
6GK60150AL200LB1 (Conformal Coated)

» **Cellular Modem Modules**

RUGGEDCOM RX1500PN LM W11

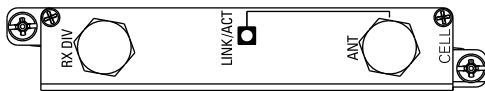

Specifications

Services: GSM/EDGE/HSPA+
Region: North America (AT&T)
Port Type: 50 Ω SMA
Antennas: 1 x GSM/EDGE/HSPA+,
1 x Receive Diversity (Secondary)
SIM: Dual Mini-SIM (2FF)

Article Numbers

6GK60150AL200WB0 (Standard)
6GK60150AL200WB1 (Conformal Coated)

RUGGEDCOM RX1500PN LM W12

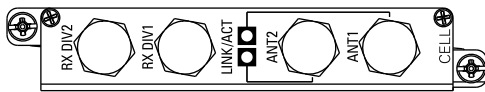

Specifications

Services: GSM/EDGE/HSPA+
Region: North America (AT&T),
European Union, Australia
Port Type: 50 Ω SMA
Antennas: 2 x GSM/EDGE/HSPA+,
2 x Receive Diversity (Secondary)
SIM: Dual Mini-SIM (2FF)

Article Numbers

6GK60150AL200WC0 (Standard)
6GK60150AL200WC1 (Conformal Coated)

RUGGEDCOM RX1500PN LM W21

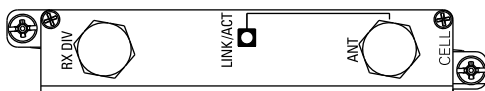

Specifications

Services: EVDO Rev A
Region: North America (Verizon)
Port Type: 50 Ω SMA
Antennas: 1 x EVDO Rev A, 1 x
Receive Diversity (Secondary)
SIM: Dual Mini-SIM (2FF)

Article Numbers

6GK60150AL200WD0 (Standard)
6GK60150AL200WD1 (Conformal Coated)

RUGGEDCOM RX1500PN LM W22

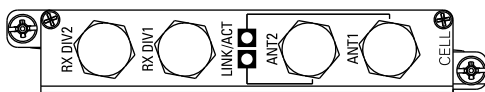

Specifications

Services: EVDO Rev A
Region: North America (Verizon)
Port Type: 50 Ω SMA
Antennas: 2 x EVDO Rev A, 2 x
Receive Diversity (Secondary)
SIM: Dual Mini-SIM (2FF)

Article Numbers

6GK60150AL200WE0 (Standard)
6GK60150AL200WE1 (Conformal Coated)

RUGGEDCOM RX1500PN LM W32

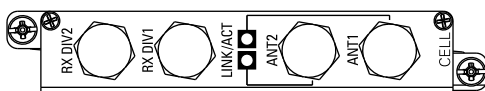

Specifications

Services: EVDO Rev A
Region: North America (Verizon)
Port Type: 50 Ω SMA

Article Numbers

6GK60150AL200WF0 (Standard)
6GK60150AL200WF1 (Conformal Coated)

Antennas: 1 x GSM/EDGE/HSPA+, 1 x EVDO Rev A, 2 x Receive Diversity (Secondary)
SIM: Dual Mini-SIM (2FF)

RUGGEDCOM RX1500PN LM W41

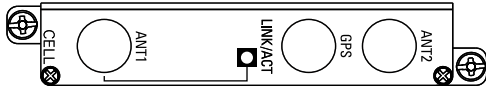

Specifications

Services: EDGE/GPRS/GSM/UMTS/HSPA+/LTE/GNSS
Region: European Union
Port Type: 50 Ω SMA
Antennas: 1 x LTE Main, 1 x LTE MIMO, 1 x GPS
SIM: Dual Mini-SIM (2FF)

Article Numbers

6GK60150AL200WG0 (Standard)
6GK60150AL200WG1 (Conformal Coated)

RUGGEDCOM RX1500PN LM W51

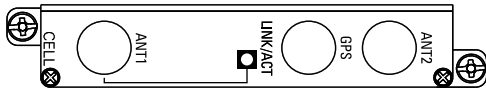

Specifications

Services: EDGE/GPRS/GSM/UMTS/HSPA+/LTE/GNSS
Region: North America (AT&T, Rogers, Bell, Telus)
Port Type: 50 Ω SMA
Antennas: 1 x LTE Main, 1 x LTE MIMO, 1 x GPS
SIM: Dual Mini-SIM (2FF)

Article Numbers

6GK60150AL200WHO (Standard)
6GK60150AL200WH1 (Conformal Coated)

RUGGEDCOM RX1500PN LM W61

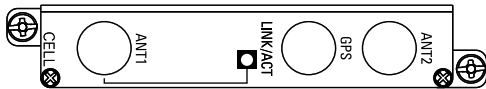

Specifications

Services: EDGE/GPRS/GSM/UMTS/HSPA+/LTE/GNSS
Region: North America (Verizon, Sprint)
Port Type: 50 Ω SMA
Antennas: 1 x LTE Main, 1 x LTE MIMO, 1 x GPS
SIM: Dual Mini-SIM (2FF)

Article Numbers

6GK60150AL200WJ0 (Standard)
6GK60150AL200WJ1 (Conformal Coated)

RUGGEDCOM RX1500PN LM W81

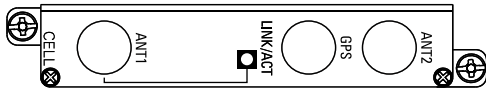

Specifications

Services: EDGE/GPRS/GSM/UMTS/HSPA+/LTE/GNSS
Region: Asia-Pacific
Port Type: 50 Ω SMA
Antennas: 1 x LTE Main, 1 x LTE MIMO, 1 x GPS
SIM: Dual Mini-SIM (2FF)

Article Numbers

6GK60150AL200WK0 (Standard)
6GK60150AL200WK1 (Conformal Coated)

» RUGGEDCOM APE Modules

 **CAUTION!**
Electrical hazard – risk of power failure. Do not install more than one RUGGEDCOMAPE module. Installing more than two of this type of module can lead to power fluctuations and irregular shut downs.

RUGGEDCOM RX1500PN LM APE1402

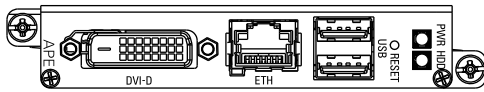

Specifications

Operating System: Debian Linux®
 Processor: Intel Atom E660 1.3 GHz, 512 KB L2 Cache
 RAM: 2 GB DDR2, 800 MHz, 32-bit
 Disk: 8 GB SATA, Solid State
 Networking: Realtek RTL8111, RJ45 Gigabit Ethernet Interface
 USB: 2 x USB 2.0^a
 Video: Intel 4108 Graphics Processor, DVI-D

Article Numbers

6GK60150AL200GB0 (Standard)
 6GK60150AL200GB1 (Conformal Coated)

RUGGEDCOM RX1500PN LM APE1402W7

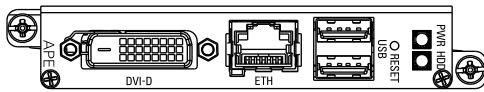

Specifications

Operating System: Windows® Embedded Standard 7
 Processor: Intel Atom E660 1.3 GHz, 512 KB L2 Cache
 RAM: 2 GB DDR2, 800 MHz, 32-bit
 Disk: 8 GB SATA, Solid State
 Networking: Realtek RTL8111, RJ45 Gigabit Ethernet Interface
 USB: 2 x USB 2.0^a
 Video: Intel 4108 Graphics Processor, DVI-D

Article Numbers

6GK60150AL200GC0 (Standard)
 6GK60150AL200GC1 (Conformal Coated)

RUGGEDCOM RX1500PN LM APE1404

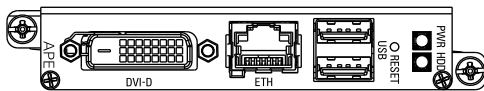

Specifications

Operating System: Debian Linux®
 Processor: Intel Atom E660T 1.3 GHz, 512 KB L2 Cache
 RAM: 2 GB DDR2, 800 MHz, 32-bit
 Disk: 16 GB SATA, Solid State
 Networking: Realtek RTL8111, RJ45 Gigabit Ethernet Interface
 USB: 2 x USB 2.0^a
 Video: Intel 4108 Graphics Processor, DVI-D

Article Numbers

6GK60150AL200GD0 (Standard)
 6GK60150AL200GD1 (Conformal Coated)

RUGGEDCOM RX1500PN LM APE1404W7

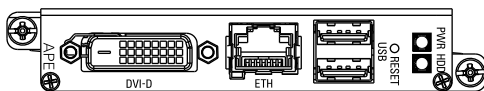

Specifications

Operating System: Windows® Embedded Standard 7
 Processor: Intel Atom E660T 1.3 GHz, 512 KB L2 Cache
 RAM: 2 GB DDR2, 800 MHz, 32-bit
 Disk: 16 GB SATA, Solid State
 Networking: Realtek RTL8111, RJ45 Gigabit Ethernet Interface
 USB: 2 x USB 2.0^a
 Video: Intel 4108 Graphics Processor, DVI-D

Article Numbers

6GK60150AL200GE0 (Standard)
 6GK60150AL200GE1 (Conformal Coated)

RUGGEDCOM RX1500PN LM APE1404CKP

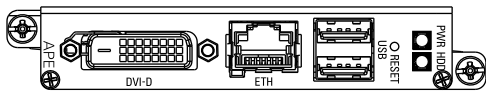

Specifications

Operating System: Check Point
GAiA™ OS

Processor: Intel Atom E660T 1.3
GHz, 512 KB L2 Cache

RAM: 2 GB DDR2, 800 MHz, 32-
bit

Disk: 16 GB SATA, Solid State

Networking: Realtek RTL8111,
RJ45 Gigabit Ethernet Interface

USB: 2 x USB 2.0^a

Video: Intel 4108 Graphics
Processor, DVI-D

Article Numbers

6GK60150AL200GF0 (Standard)

6GK60150AL200GF1 (Conformal
Coated)

^a Maximum combined USB device power consumption is 500 mA at 5 V.

Section 3.2

Installing/Removing Line Modules

Upon installing a new line module in the device, all features associated with the module are available in RUGGEDCOM ROX II. For more information, refer to the *RUGGEDCOM ROX II User Guide* for the RUGGEDCOM RX1512.

Once a line module is removed, all the features associated with the module are hidden or disabled in RUGGEDCOM ROX II.



CAUTION!

Electrical hazard – risk of power failure. Do not install more than one RUGGEDCOMAPE module. Installing more than two of this type of module can lead to power fluctuations and irregular shut downs.



IMPORTANT!

Only one WAN line module is supported per chassis.



CAUTION!

Contamination hazard – risk of equipment damage. Prevent the ingress of water, dirt and other debris that may lead to premature equipment failure. Always make sure slots are not left empty and open ports are protected with plugs or covers.

» Removing a Module

To remove a line module, do the following:

1. Make sure power to the device has been disconnected and wait approximately two minutes for any remaining energy to dissipate.
2. [Optional] If the device is installed in a rack, remove it from the rack.
3. Loosen the screws that secure the module.
4. Pull the module from the chassis to disconnect it.

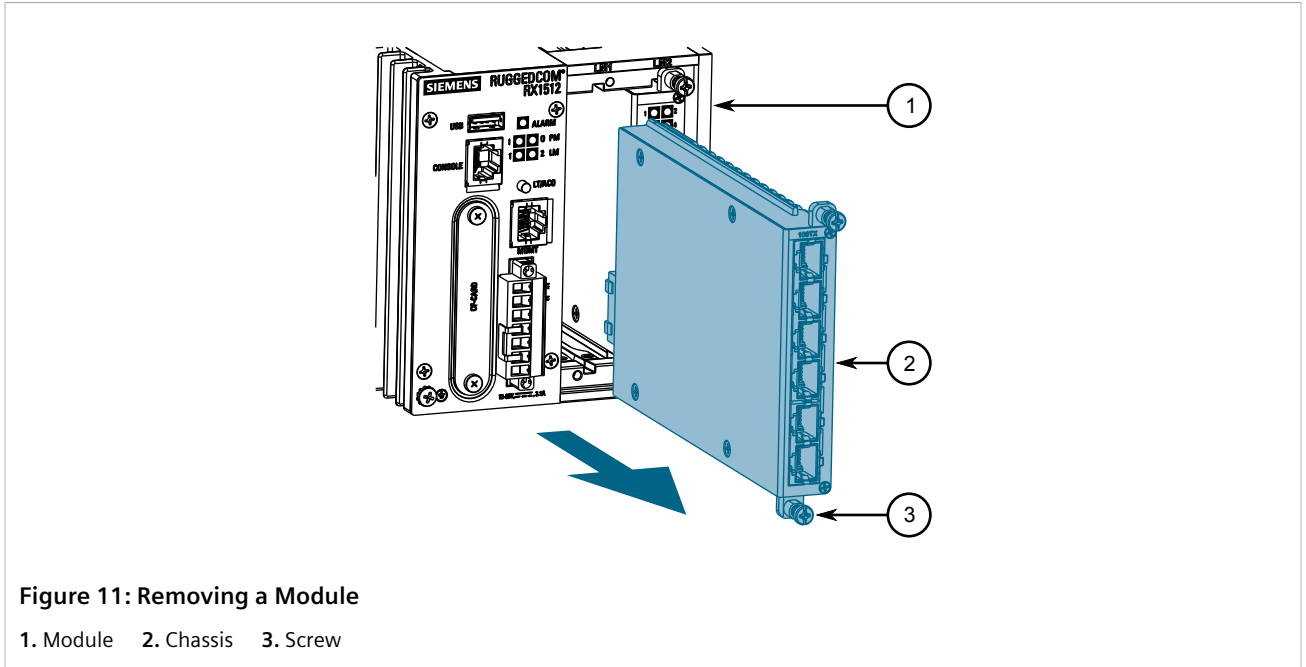

5. Install a new module or a blank module (to prevent the ingress of dust and dirt).
6. [Optional] If necessary, install the device in the rack.
7. Connect power to the device.

» Installing a Module

To install a line module, do the following:

1. Make sure power to the device has been disconnected and wait approximately two minutes for any remaining energy to dissipate.
2. [Optional] If the device is installed in a rack, remove it from the rack.
3. Remove the current module from the slot.
4. Insert the new module into the slot.

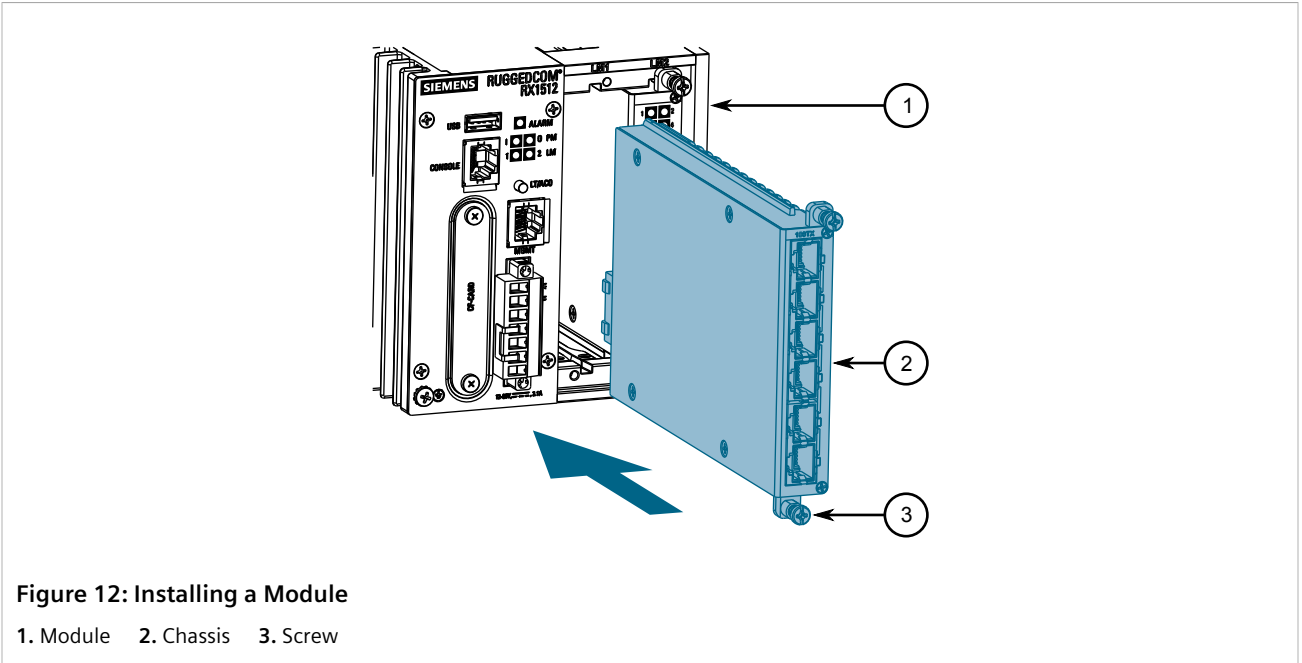

5. Tighten the screws to secure the module.
6. [Optional] If necessary, install the device in the rack.
7. Connect power to the device.

4 Technical Specifications

This section provides important technical specifications related to the device.

CONTENTS

- [Section 4.1, "Power Supply Specifications"](#)
- [Section 4.2, "Failsafe Relay Specifications"](#)
- [Section 4.3, "Operating Environment"](#)
- [Section 4.4, "Mechanical Specifications"](#)

Section 4.1

Power Supply Specifications

Power Supply Type	Input Range		Internal Fuse Rating	Maximum Power Consumption ^a	Maximum Cable Length ^b	Insulation
	Min	Max				
Internal	11 VDC	72 VDC	6.3 A	26.4 W	—	

^a Power consumption varies based on the device configuration.

^b Based on #16 AWG wiring.

Section 4.2

Failsafe Relay Specifications

Maximum Switching Voltage	Rated Switching Current	Isolation
30 VDC	2 A, 60 W	1500 V _{rms} for 1 minute
125 VDC	0.24 A, 30 W	
125 VAC	0.5 A, 62.5 W	
220 VDC	0.24 A, 60 W	
250 VAC	0.25 A, 62.5 W	

Section 4.3

Operating Environment

The RUGGEDCOM RX1512 is rated to operate under the following environmental conditions.



IMPORTANT!

Temperature limits for select line modules may differ from that which can be withstood by the RUGGEDCOM RX1512. Make sure the selected modules are rated for the expected environmental conditions before deployment. For more information, refer to the RUGGEDCOM RX1512 Series Modules Catalog.

Parameter	Range	Comments
Ambient Operating Temperature	-40 to 85 °C (-40 to 185 °F) ^c	Measured from a 30 cm (12 in) radius surrounding the center of the enclosure.
Ambient Relative Humidity	5% to 95%	Non-condensing
Ambient Storage Temperature	-40 to 85 °C (-40 to 185 °F)	

^c Maximum ambient operating temperature is 70 °C (158 °F) when the device is installed along with Underwriter Laboratories (UL) listed devices.

Section 4.4

Mechanical Specifications

Dimensions	Refer to Chapter 5, Dimension Drawings
Weight	Approximately 2.3 kg (5 lb)
Ingress Protection	IP40
Enclosure	Aluminum

5 Dimension Drawings



NOTE

All dimensions are in millimeters, unless otherwise stated.

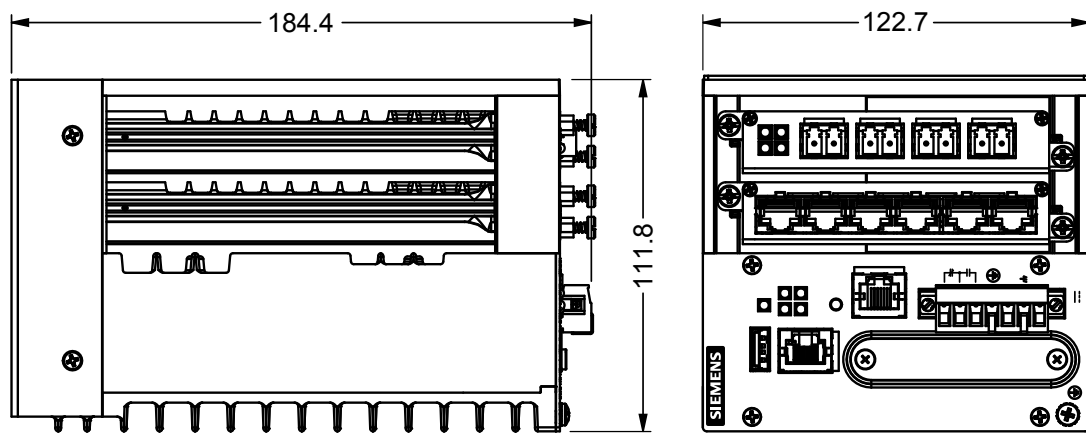

Figure 13: Overall Dimensions

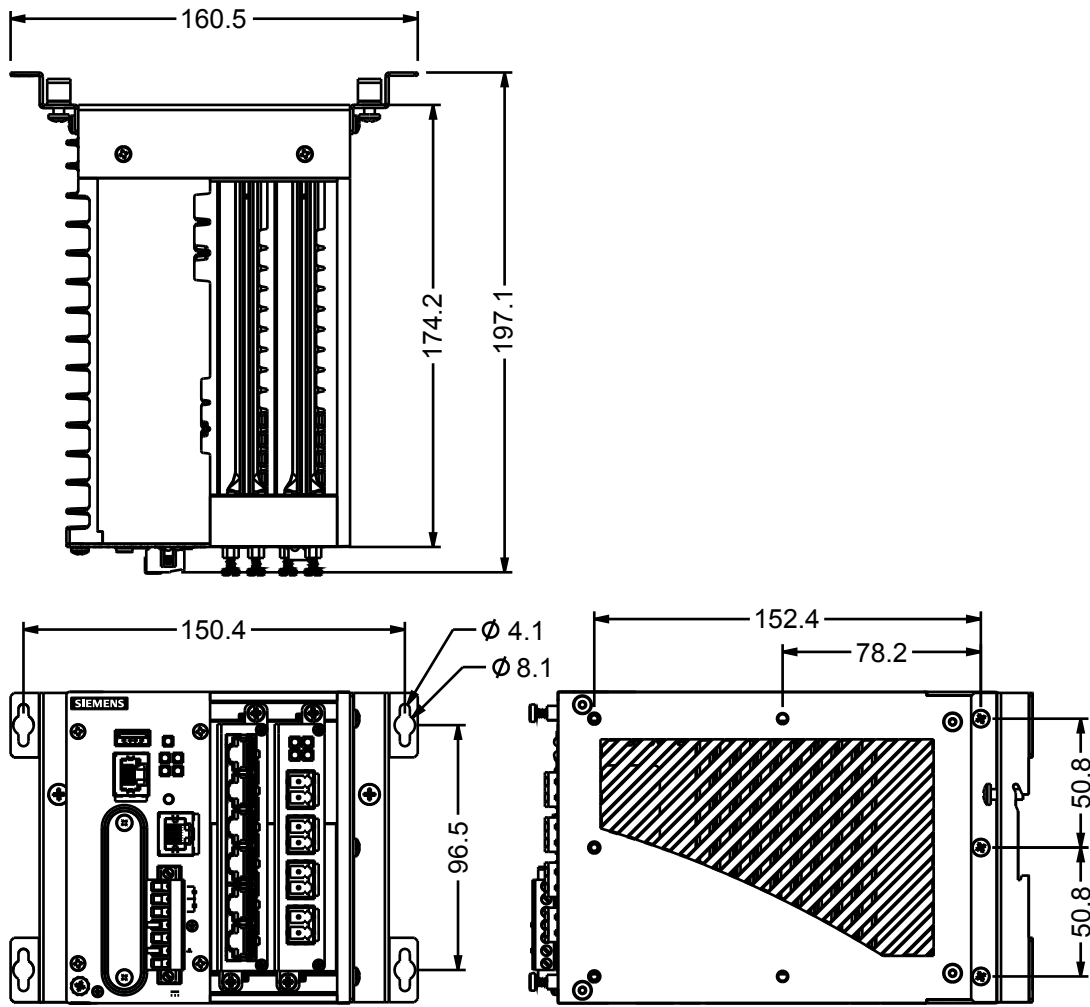

Figure 14: Panel and Din Rail Mount Dimensions

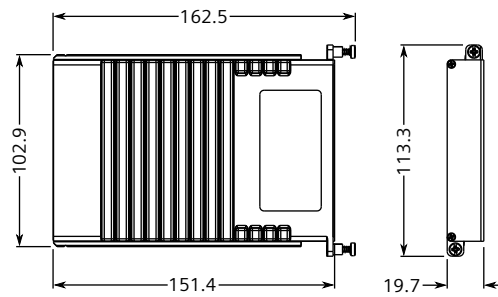

Figure 15: Line Module Dimensions

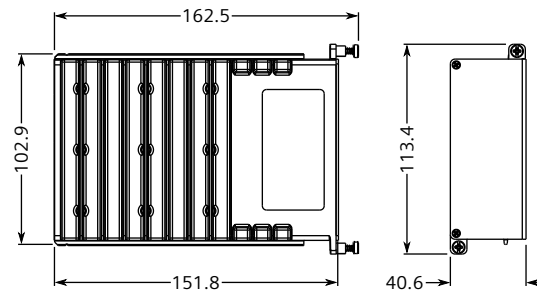

Figure 16: Power Module Dimensions

6 Certification

The RUGGEDCOM RX1512 device has been thoroughly tested to guarantee its conformance with recognized standards and has received approval from recognized regulatory agencies.

**NOTE**

Certifications related to individual modules are detailed in the RUGGEDCOM Modules Catalog for the device available online.

CONTENTS

- [Section 6.1, "Approvals"](#)
- [Section 6.2, "EMC and Environmental Type Tests"](#)

Section 6.1

Approvals

This section details the standards to which the RUGGEDCOM RX1512 complies.

CONTENTS

- [Section 6.1.1, "TÜV SÜD"](#)
- [Section 6.1.2, "European Union \(EU\)"](#)
- [Section 6.1.3, "FCC"](#)
- [Section 6.1.4, "FDA/CDRH"](#)
- [Section 6.1.5, "ISED"](#)
- [Section 6.1.6, "RoHS"](#)
- [Section 6.1.7, "Other Approvals"](#)

Section 6.1.1

TÜV SÜD

This device is certified by TÜV SÜD to meet the requirements of the following standards:

- **CAN/CSA-C22.2 NO. 60950-1-07 (R2012)**
Information Technology Equipment – Safety – Part 1: General Requirements (Bi-National standard, with UL 60950-1)
- **UL 60950-1**
Information Technology Equipment – Safety – Part 1: General Requirements)

Section 6.1.2

European Union (EU)

This device is declared by Siemens Canada Ltd to comply with essential requirements and other relevant provisions of the following EU directives:

- **Directive 2014/30/EU**
Directive 2014/30/EU of the European Parliament and of the Council of 26 February 2014 on the harmonisation of the laws of the Member States relating to electromagnetic compatibility (recast) Text with EEA relevance
- **Directive 2014/35/EU**
Directive 2014/35/EU of the European Parliament and of the Council of 26 February 2014 on the harmonisation of the laws of the Member States relating to the making available on the market of electrical equipment designed for use within certain voltage limits Text with EEA relevance
- **Directive 2011/65/EU**
Directive 2011/65/EU of the European Parliament and of the Council of 8 June 2011 on the restriction of the use of certain hazardous substances in electrical and electronic equipment Text with EEA relevance
- **Directive 1999/5/EC**
Directive 1999/5/EC of the European Parliament and of the Council of 9 March 1999 on radio equipment and telecommunications terminal equipment and the mutual recognition of their conformity
- **EN 60950-1**
Information Technology Equipment – Safety – Part 1: General Requirements
- **EN 61000-3-2**
Electromagnetic compatibility (EMC) – Part 3-2: Limits – Limits for harmonic current emissions (equipment input current ≤ 16 A per phase)
- **EN 61000-3-3**
Electromagnetic compatibility (EMC) – Part 3-3: Limits – Limitation of voltage changes, voltage fluctuations and flicker in public low-voltage supply systems, for equipment with rated current ≤ 16 A per phase and not subject to conditional connection
- **EN 61000-6-2**
Electromagnetic Compatibility (EMC) – Part 6-2: Generic Standards – Immunity for Industrial Environments
- **EN 60825-1**
Safety of Laser Products – Equipment Classification and Requirements
- **EN 50581**
Technical Documentation for the Assessment of Electrical and Electronic Products with Respect to the Restriction of Hazardous Substances
- **EN 55022**
Information Technology Equipment – Radio Disturbance Characteristics – Limits and Methods of Measurement

The device is marked with a CE marking and notified body number, and can be used throughout the European community.

CE 0680

A copy of the CE Declaration of Conformity is available from Siemens Canada Ltd. For contact information, refer to [“Contacting Siemens”](#).

Section 6.1.3

FCC

This device has been tested and found to comply with the limits for a Class A digital device, pursuant to Part 15 of the FCC Rules. These limits are designed to provide reasonable protection against harmful interference when the equipment is operated in a commercial environment.

This device generates, uses and can radiate radio frequency energy and, if not installed and used in accordance with the instruction manual, may cause harmful interference to radio communications. Operation of this equipment in a residential area is likely to cause harmful interference in which case users will be required to correct the interference at their own expense.



IMPORTANT!

Changes or modifications not expressly approved by the party responsible for compliance could void the user's authority to operate this device.

Section 6.1.4

FDA/CDRH

This device meets the requirements of the following U.S. Food and Drug Administration (FDA) standard:

- Title 21 Code of Federal Regulations (CFR) – Chapter I – Sub-chapter J – Radiological Health

Section 6.1.5

ISED

This device is declared by Siemens Canada Ltd to meet the requirements of the following ISED (Innovation Science and Economic Development Standard Canada) standard:

- CAN ICES-3 (A)/NMB-3 (A)

Section 6.1.6

RoHS

This device is declared by Siemens Canada Ltd to meet the requirements of the following RoHS (Restriction of Hazardous Substances) directives for the restricted use of certain hazardous substances in electrical and electronic equipment:

- **China RoHS 2**
Administrative Measure on the Control of Pollution Caused by Electronic Information Products

A copy of the Material Declaration is available online at <https://support.industry.siemens.com/cs/us/en/view/109738831> .

Section 6.1.7

Other Approvals

This device meets the requirements of the following additional standards:

- **IEEE 1613**
IEEE Standard Environmental and Testing Requirements for Communications Networking Devices in Electric Power Substations
- **IEC 61000-6-2**
Electromagnetic Compatibility (EMC) – Part 6-2: Generic Standards – Immunity for Industrial Environments
- **IEC 61850-3**
Communication Networks and Systems in Substations – Part 3: General Requirements

Section 6.2

EMC and Environmental Type Tests

The RUGGEDCOM RX1512 has passed the following Electromagnetic Compatibility (EMC) and environmental tests.

» EMC Type Test for IEC 61850-3

Test	Description		Test Levels	Severity Levels
IEC 61000-4-2	ESD	Enclosure Contact	± 8 kV	4
		Enclosure Air	± 15 kV	
IEC 61000-4-3	Radiated RFI	Enclosure Ports	20 V/m	Note ^a
IEC 61000-4-4	Burst (Fast Transient)	Signal ports	± 4 kV @ 2.5 kHz	
		DC Power Ports	± 4 kV	4
		Earth ground ports		
IEC 61000-4-5	Surge	Signal ports	± 2 kV Line-to-Ground ± 2 kV Line-to-Line	4
		DC Power Ports	± 2 kV Line-to-Ground ± 1 kV Line-to-Line	3
IEC 61000-4-6	Induced (Conducted) RFI	Signal ports	10 V	3
		DC Power Ports		
		Earth ground ports		
IEC 61000-4-8	Magnetic Field	Enclosure Ports	100 A/m, continuous 1000 A/m for 1 s	Note ^a
			1000 A/m for 1 s	5
IEC 61000-4-12	Damped Oscillatory	Signal ports	2.5 kV common, 1 kV differential mode @1 MHz	3
		DC Power Ports		
IEC 61000-4-16	Mains Frequency Voltage	Signal ports	30 V Continuous	4

Test	Description		Test Levels	Severity Levels
		DC Power Ports	300 V for 1 s	
IEC 61000-4-17	Ripple on DC Power Supply	DC Power Ports	10%	3
IEC 61000-4-29	Voltage Dips and Interrupts	DC Power Ports	30% for 0.1 s 60% for 0.1 s 100% for 0.05 s	
IEC 60255-5	Dielectric Strength	Signal ports	2 kV (Failsafe Relay output)	
		DC Power Ports	2 kV	
	HV Impulse	Signal ports	5 kV (Failsafe Relay output)	
		DC Power Ports	5 kV	

^a Siemens-specified severity levels

» EMC Immunity Type Tests for IEEE 1613



NOTE

The RUGGEDCOM RX1512 meets Class 2 requirements for an all-fiber configuration and Class 1 requirements for copper ports. Class 1 allows for temporary communication loss, while Class 2 requires error-free and interrupted communications.

Description		Test Levels
HV Impulse	Signal ports	5 kV (Failsafe Relay Output)
	DC Power Ports	5 kV
Dielectric Strength	Signal ports	2 kV
	DC Power Ports	2 kV
Fast Transient	Signal ports	± 4 kV @ 2.5 kHz
	DC Power Ports	± 4 kV
	Earth ground ports	
Oscillatory	Signal ports	2.5 kV common mode @1MHz
	DC Power Ports	2.5 kV common 1 kV differential mode @ 1 MHz
Radiated RFI	Enclosure ports	35 V/m
ESD	Enclosure Contact	± 8 kV
	Enclosure Air	± 15 kV

» Environmental Type Tests

Test	Description		Test Levels	Severity Levels
IEC 60068-2-1	Cold Temperature	Test Ad	-40 °C (-40 °F), 16 Hours	

Test	Description		Test Levels	Severity Levels
IEC 60068-2-2	Dry Heat	Test Bd	85 °C (185 °F), 16 Hours	
IEC 60068-2-30	Humidity (Damp Heat, Cyclic)	Test Db	95% (non-condensing), 55 °C (131 °F), 6 cycles	
IEC 60255-21-1	Vibration		2 g @ 10-150 Hz	Class 2
IEC 60255-21-2	Shock		30 g @ 11 ms	Class 2
	Bump		10 g @ 16 ms	Class 1
IEC 60255-21-3	Seismic		Method A	Level 2