

Pump control panel, Size 3, Three phase full voltage, Solid-state overload relay, OLR amp range 25-100A, 380-440/440-480V 50/60Hz coil, Standard type contactor, 200A fusible disconnect, 200A/600V fuse clip, HOA Sel Sw. & Start P.B., Enclosure NEMA type 3/3R, Weather proof outdoor use



Figure similar

Product brand name	Class 87
Design of the product	Pump control panel with fused disconnect switch
Special product feature	ESP200 overload relay

General technical data	
Weight [lb]	81 lb
Height x Width x Depth [in]	41 × 24 × 8 in
Protection against electrical shock	NA for enclosed products
Installation altitude [ft] at height above sea level maximum	6560 ft
Ambient temperature [°F]	
• during storage maximum	149 °F
• during operation maximum	104 °F
Ambient temperature	
• during storage maximum	65 °C
• during operation maximum	40 °C
Country of origin	USA

Horsepower ratings

Yielded mechanical performance [hp] for three-phase AC motor	
<ul style="list-style-type: none"> • at 200/208 V rated value 	0 hp
<ul style="list-style-type: none"> • at 220/230 V rated value 	0 hp
<ul style="list-style-type: none"> • at 460/480 V rated value 	50 hp
<ul style="list-style-type: none"> • at 575/600 V rated value 	50 hp

Contactors

Size of contactor	NEMA controller size 3
Number of NO contacts for main contacts	3
Operating voltage for main current circuit at AC at 60 Hz maximum	600 V
Operating current at AC at 600 V rated value	90 A
Mechanical service life (switching cycles) of the main contacts typical	5000000

Auxiliary contact

Number of NC contacts at contactor for auxiliary contacts	0
Number of NO contacts at contactor for auxiliary contacts	1
Number of total auxiliary contacts maximum	7
Contact rating of auxiliary contacts of contactor according to UL	10A@600VAC (A600), 5A@600VDC (P600)

Coil

Type of voltage of the control supply voltage	AC
Control supply voltage	
<ul style="list-style-type: none"> • at DC rated value 	0 ... 0 V
<ul style="list-style-type: none"> • at AC at 50 Hz rated value 	380 ... 440 V
<ul style="list-style-type: none"> • at AC at 60 Hz rated value 	440 ... 480 V
Holding power at AC minimum	14 W
Apparent pick-up power of magnet coil at AC	310 V·A
Operating range factor control supply voltage rated value of magnet coil	0.85 ... 1.1
Percental drop-out voltage of magnet coil related to the input voltage	50 %
Switch-on delay time	26 ... 41 ms
Off-delay time	14 ... 19 ms

Overload relay

Product function	
<ul style="list-style-type: none"> • Overload protection 	Yes
<ul style="list-style-type: none"> • Phase failure detection 	Yes
<ul style="list-style-type: none"> • Phase unbalance 	Yes
<ul style="list-style-type: none"> • Ground fault detection 	Yes

<ul style="list-style-type: none"> • Test function 	Yes
<ul style="list-style-type: none"> • External reset 	Yes
Reset function	Manual, automatic and remote
Trip class	Class 5 / 10 (factory set) / 20 / 30
Adjustable pick-up value current of the current-dependent overload release	25 ... 100 A
Trip time at phase-loss maximum	3 s
Relative repeat accuracy	1 %
Product feature Protective coating on printed-circuit board	Yes
Number of NC contacts of auxiliary contacts of overload relay	1
Number of NO contacts of auxiliary contacts of overload relay	1
Operating current of auxiliary contacts of overload relay	
<ul style="list-style-type: none"> • at AC at 600 V 	5 A
<ul style="list-style-type: none"> • at DC at 250 V 	1 A
Contact rating of auxiliary contacts of overload relay according to UL	5A@600VAC (B600), 1A@250VDC (R300)
Insulation voltage	
<ul style="list-style-type: none"> • with single-phase operation at AC rated value 	600 V
<ul style="list-style-type: none"> • with multi-phase operation at AC rated value 	300 V

Disconnect Switch

Rated response values of switch disconnect	200A / 600V
Design of fuse holder	Class H fuse clips
Operating class of the fuse link	Class H, J (convertible), K and R

Enclosure

Degree of protection NEMA rating of the enclosure	NEMA 3/3R
Design of the housing	Weather proof for outdoor use

Standard Control Devices

Product component Hand-Off-Auto selector switch	Yes
Type of Hand-Off-Auto selector switch	30mm metal housing with chrome finish
Product component Start push button	Yes
Type of start push button	30mm metal housing with chrome finish

Mounting/wiring

Mounting position	Vertical
Mounting type	Surface mounting and installation
Type of electrical connection for supply voltage line-side	Box lug
Type of connectable conductor cross-sections at line-side at AWG conductors single or multi-stranded	1x (6 AWG ... 300 Kcmil)

Temperature of the conductor for supply maximum permissible	75 °C
Material of the conductor for supply	AL or CU
Type of electrical connection for load-side outgoing feeder	Box lug
Tightening torque [lbf-in] for load-side outgoing feeder	120 ... 120 lbf-in
Type of connectable conductor cross-sections at AWG conductors for load-side outgoing feeder single or multi-stranded	1x (14 ... 2/0 AWG)
Temperature of the conductor for load-side outgoing feeder maximum permissible	75 °C
Material of the conductor for load-side outgoing feeder	AL or CU
Type of electrical connection of magnet coil	Screw-type terminals
Tightening torque [lbf-in] at magnet coil	5 ... 12 lbf-in
Type of connectable conductor cross-sections of magnet coil at AWG conductors single or multi-stranded	2x (16 ... 12 AWG)
Temperature of the conductor at magnet coil maximum permissible	75 °C
Material of the conductor at magnet coil	CU
Type of electrical connection at contactor for auxiliary contacts	Screw-type terminals
Tightening torque [lbf-in] at contactor for auxiliary contacts	10 ... 15 lbf-in
Type of connectable conductor cross-sections at contactor at AWG conductors for auxiliary contacts single or multi-stranded	1x (12 AWG), 2x (16 ... 14 AWG), 2x (18 ... 16 AWG)
Temperature of the conductor at contactor for auxiliary contacts maximum permissible	75 °C
Material of the conductor at contactor for auxiliary contacts	CU
Type of electrical connection at overload relay for auxiliary contacts	Screw-type terminals
Tightening torque [lbf-in] at overload relay for auxiliary contacts	7 ... 10 lbf-in
Type of connectable conductor cross-sections at overload relay at AWG conductors for auxiliary contacts single or multi-stranded	2x (20 ... 14 AWG)
Temperature of the conductor at overload relay for auxiliary contacts maximum permissible	75 °C
Material of the conductor at overload relay for auxiliary contacts	CU

Short-circuit current rating

Design of the fuse link for short-circuit protection of the main circuit required	10kA@600V (Class H or K); 100kA@600V (Class R or J)
Certificate of suitability	NEMA ICS 2; UL 508

Further information

Industrial Controls - Product Overview (Catalogs, Brochures,...)

www.usa.siemens.com/iccatalog

Industry Mall (Online ordering system)

<https://mall.industry.siemens.com/mall/en/us/Catalog/product?mlfb=US2:87HUG60H>

Service&Support (Manuals, Certificates, Characteristics, FAQs,...)

<https://support.industry.siemens.com/cs/US/en/ps/US2:87HUG60H>

Image database (product images, 2D dimension drawings, 3D models, device circuit diagrams, EPLAN macros, ...)

http://www.automation.siemens.com/bilddb/cax_de.aspx?mlfb=US2:87HUG60H&lang=en

Certificates/approvals

<https://support.industry.siemens.com/cs/US/en/ps/US2:87HUG60H/certificate>

LETTER	CONDUIT SIZE
A	%%C22.2 & %%C28.6 CONDUIT
B	Ø50 & Ø62.7 CONDUIT

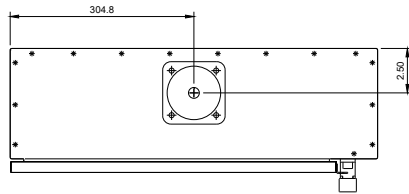
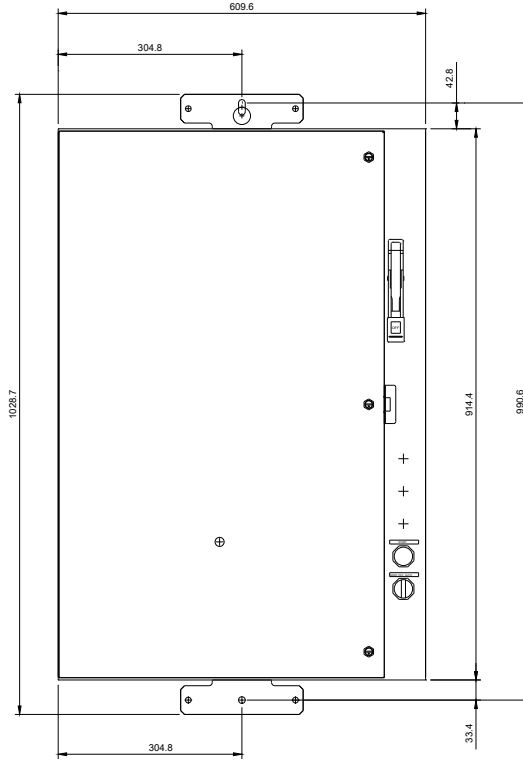
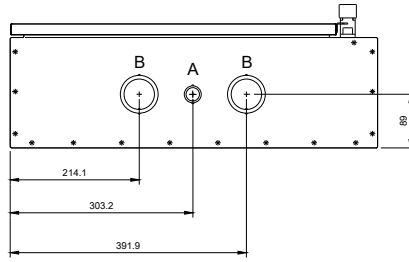
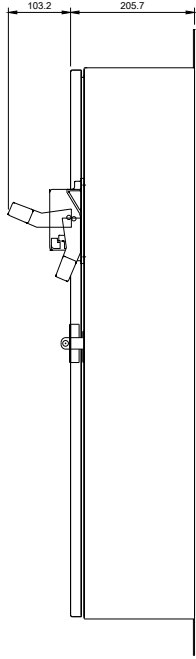

CONDUIT HUB COVER

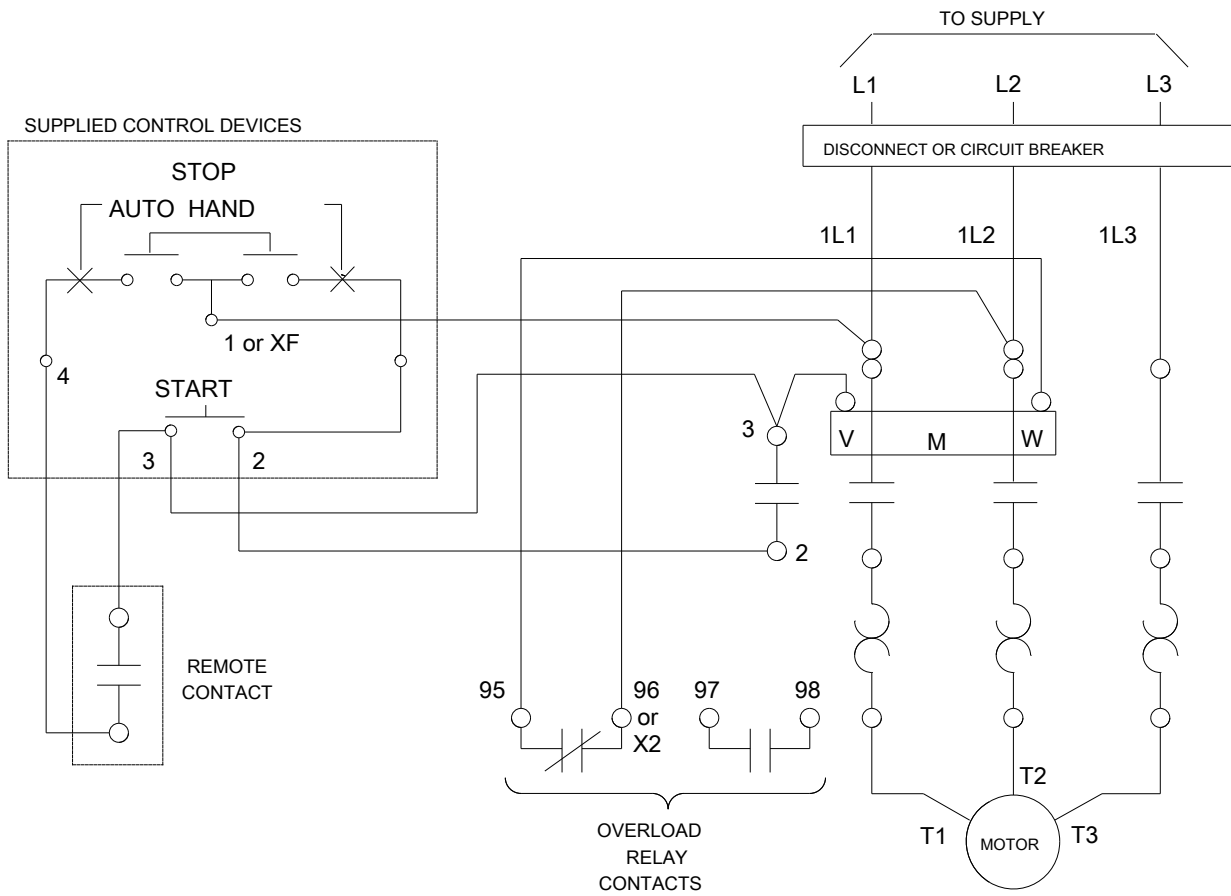

D63677012

last modified:

11/15/2019