

SIEMENS

Door mounted rotary operator

Türkupplungsdrehantrieb

Commande rotative de porte

Mando giratorio de puerta

Comando rotativo bloccoporta

Acionamento giratório do acoplamento da porta

Капі kolu döner tahrik mekanizması

Поворотный привод сцепления двери

Narzęd obrotowy sprzęgu drzwi

门耦合旋转驱动器



8UD1721-0AB..	8UD1731-0AC..	8UD1900-.GA00	8UD1900-.DA00
8UD1721-0AC..	8UD1741-0AB..	8UD1900-.HA00	
8UD1731-0AB..	8UD1741-0AC..	8UD1900-.W.00	

<i>Operating Instructions</i>	<i>Betriebsanleitung</i>	<i>Notice d'utilisation</i>	<i>Instructivo</i>	<i>Istruzioni operative</i>
<i>Instruções de Serviço</i>	<i>İşletme kılavuzu</i>	<i>Руководство по эксплуатации</i>	<i>Instrukcja obsługi</i>	<i>使用说明</i>

		EN DANGER Hazardous voltage. Will cause death or serious injury. Turn off and lock out all power supplying this device before working on this device. Replace all covers before power supplying this device is turned on.
		NOTICE Installation and maintenance must be carried out by qualified personnel.
DE GEFAHR Gefährliche Spannung. Lebensgefahr oder schwere Verletzungsgefahr. Bevor Arbeiten am Gerät durchgeführt werden, müssen alle Stromquellen ausgeschaltet und mit einer Einschaltssicherung versehen werden. Vor dem Wiedereinschalten der Stromquellen müssen alle Abdeckungen wieder angebracht werden.	FR DANGER Tension électrique dangereuse. Danger de mort ou risque de blessures graves. Avant d'intervenir sur l'appareil, couper toutes les sources de tension et les consigner contre la refermeture. Remettre en place tous les couvercles avant de remettre l'appareil sous tension.	
HINWEIS Installations- und Wartungsarbeiten sind von qualifiziertem Personal durchzuführen.	NOTIFICATION L'installation et la maintenance doivent être effectuées uniquement par des personnes qualifiées.	
ES PELIGRO Tensión peligrosa. Puede causar la muerte o lesiones graves. Antes de trabajar en este dispositivo, desconecte y bloquee todas las fuentes que lo alimentan eléctricamente. Recoloque todas las cubiertas antes de volver a conectar la alimentación eléctrica para este dispositivo.	IT PERICOLO Tensione pericolosa. Può causare la morte o lesioni gravi. Prima di lavorare su questa apparecchiatura, disinserire tutte le fonti di alimentazione elettrica dell'apparecchiatura ed assicurarle contro la reinserzione. Riapplicare tutte le coperture prima di reinserire l'alimentazione di questa apparecchiatura.	
NOTA La instalación y el mantenimiento deben corre a cargo de personal cualificado.	NOTA L'installazione e la manutenzione devono essere eseguite da personale qualificato.	
PT PERIGO Tensão perigosa. Perigo de morte ou ferimentos graves. Desligue e bloqueie todas as fontes de alimentação antes de executar quaisquer trabalhos no aparelho. Volte a colocar todas as coberturas antes de voltar a ligar as fontes de alimentação.	TR TEHLİKE Tehlikeli gerilim. Ölüm tehlikesi veya ağır yaralanma tehlikesi mevcuttur. Cihazda çalışmalar yapılmadan önce, tüm güç kaynakları kapatılmalı ve bir açma emniyetiyle donatılmalıdır. Güç kaynakları tekrar açılmadan önce tüm kapaklar yerlerine takılmalıdır.	
ATENÇÃO A instalação e manutenção têm de ser efetuadas por pessoal qualificado.	NOT Montaj ve bakım işlemleri kalifiye personel tarafından yapılmalıdır.	
РУ ОПАСНО Опасное напряжение. Опасность для жизни или телесных повреждений. До начала работы выключите и заблокируйте все источники питания этого устройства. Перед включением питания снова установите все крышки.	PL ZAGROŻENIE Niebezpieczne napięcie. Niebezpieczeństwo poważnych obrażeń lub utraty życia. Wyłączyć i zablokować wszystkie źródła zasilania urządzenia przed rozpoczęciem pracy na urządzeniu. Założyć wszystkie osłony przed podłączeniem urządzenia do źródła zasilania.	
ПРИМЕЧАНИЕ Установка и техническое обслуживание должны производиться квалифицированным персоналом.	UWAGA Instalacja i konserwacja muszą być wykonywane przez wykwalifikowany personel.	

Technical Support: [Internet: https://www.siemens.com/lowvoltage/technical-support](https://www.siemens.com/lowvoltage/technical-support)

<p>中  危险</p> <p>危险电压。可能导致生命危险或重伤危险。操作此设备前必须确保切断其电源并采取防接通保护措施。在设备接通电源前，更换所有盖板。</p>	<p>HR  OPASNOST</p> <p>Opasni napon. Opasnost po život ili opasnost od teških ozljeda. Prije rada na uređaju moraju biti isključeni svi izvori struje i osigurati uređaj zaštitom od uključivanja. Prije ponovnog uključivanja izvora struje moraju se opet postaviti svi poklopci.</p>
<p> 注意</p> <p>安装和维护必须由具备专业资质的人员进行。</p>	<p> NAPOMENA</p> <p>Montažu i održavanje mora obavljati kvalificirano osoblje.</p>
<p>FI  VAARA</p> <p>Vaarallinen jännite. Vakava loukkaantumisvaara tai hengenvaara. Laitteen kaikki virransyöttö tulee katkaista ja sen kytkäminen päälle tulee estää lukolla ennen kuin laitteeseen kohdistetaan mitään toimenpiteitä. Kaikki kotelot tulee kiinnittää takaisin ennen kuin laitteen virransyöttö kytketään uudelleen päälle.</p>	<p>БГ  ОПАСНОСТ</p> <p>Опасно напряжение. Опасност за живота или опасност от тежки телесни повреди. Преди да извършвате дейности по устройството, изключете и обезопасете всички захранващи източници. Поставете всички капаци на мястото им, преди отново да включите захранването на устройството.</p>
<p> HUOMAUTUS</p> <p>Asennus- ja huoltotyöt on annettava pätevän ammattilaisen suoritettaviksi.</p>	<p> ПРЕДУПРЕЖДЕНИЕ</p> <p>Инсталирането и поддръжката трябва да се извършват от квалифициран персонал.</p>
<p>EE  OHT</p> <p>Ohtlik pinge. Oht elule või raskete vigastuste oht. Enne seadme hooldustöid lülitage kõik toiteallikad välja ja võtke meetmed nende sisselülitamise takistamiseks. Enne toiteallikate uuesti sisselülitamist tuleb kõik katted tagasi paigaldada.</p>	<p>LV  BĪSTAMI</p> <p>Bīstams spriegums. Letālu seku vai smagu traumu risks. Pirms veicat darbu ar šo ierīci pilnībā izslēdziet un nobloķējiet tās strāvas padevi. Pirms ieslēdzat ierīces strāvas padevi uzlieciet atpakaļ visus pārsegus.</p>
<p> MÄRKUS</p> <p>Paigaldus- ja hooldustöid tohib teha ainult kvalifitseeritud personal.</p>	<p> BRĪDINĀJUMS</p> <p>Uzstādīšana un tehniskā apkope jāveic kvalificētiem darbiniekiem.</p>
<p>LT  PAVOJUS</p> <p>Pavojinga įtampa. Pavojus gyvybei arba sunkaus susižalojimo pavojus. Prieš dirbdami ties šiuo prietaisu, išjunkite ir užblokuokite visus šio prietaiso maitinimo šaltinius. Prieš įjungdami šio prietaiso maitinimo šaltinį, vėl uždėkite visus dangčius.</p>	<p>DA  FARE</p> <p>Farlig spænding. Livsfare eller risiko for slemme kvæstelser. Sluk for og lås strømmen, der forsyner denne enhed, før du arbejder med denne enhed. Erstat alle afdækninger, før strømmen, der tilføres denne enhed, tændes.</p>
<p> NUORODA</p> <p>Įrengimą ir techninę priežiūrą turi vykdyti kvalifikuoti darbuotojai.</p>	<p> BEMÆRK</p> <p>Installationen og vedligeholdelsen skal foretages af uddannet personale.</p>
<p>MT  PERIKLU</p> <p>Vultaġġ perikoluż. Riskju ta' mewt jew korriment serju. Qabel taħdem fuq dan l-apparat, itfi kull provvista tal-elettriku tiegħu u sakkar kontra xegħil mill-ġdid aċċidentali. Erga' installa l-ghotjien kollha qabel tirritorna l-provvista tal-elettriku fl-apparat.</p>	<p>NL  GEVAAR</p> <p>Gevaarlijke spanning. Levensgevaar of gevaar voor ernstig letsel. Voordat u aan dit apparaat werkt, moet u alle actieve energiebronnen voor dit apparaat uitschakelen. Plaats alle afdekkingen terug voordat u energiebronnen voor dit apparaat inschakelt.</p>
<p> AVVIŻ</p> <p>L-installazzjoni u l-manutenzjoni għandhom jittwettqu minn personal ikkwalifikat.</p>	<p> OPMERKING</p> <p>Installatie en onderhoud moeten worden verricht door gekwalificeerd personeel.</p>
<p>EL  ΚΙΝΔΥΝΟΣ</p> <p>Επικίνδυνη τάση. Κίνδυνος για τη ζωή ή σοβαρού τραυματισμού. Απενεργοποιήστε και ασφαλίστε όλη την ενέργεια που τροφοδοτεί τη συσκευή, προτού εργαστείτε σε αυτή. Τοποθετήστε ξανά όλα τα καλύμματα, προτού ενεργοποιήσετε την τροφοδοσία της συσκευής με ενέργεια.</p>	<p>GA  CONTÚIRT</p> <p>Voltaas contúirteach. Baol go bhfaighfear bás nó tromghortú. Mích gach cumhacht a sholáthraíonn an gléas seo agus glasáil amach í roimh obair a dhéanamh ar an ngléas seo. Cuir na clúdaigh ar fad ar ais roimh an gcumhacht a sholáthraíonn an gléas seo a chur ar siúl arís.</p>
<p> ΠΡΟΣΟΧΉ</p> <p>Η εγκατάσταση και συντήρηση πρέπει να διεξάγονται από εξειδικευμένο προσωπικό.</p>	<p> FÓGRA</p> <p>Ní mór don fheistiú agus don chothabháil a bheith déanta ag pearsanra cáilithe.</p>
<p>RO  PERICOL</p> <p>Tensiune periculoasă. Pericol de moarte sau de accidentări grave. Opriți și blocați alimentarea cu energie a acestui dispozitiv înainte de a lucra la acesta. Așezați la loc toate capacele înainte de a porni alimentarea cu energie a acestui dispozitiv.</p>	<p>SV  FARA</p> <p>Farlig spänning. Livsfara eller risk för allvarliga personskador. Innan arbete utförst på utrustningen ska strömförsörjningen till utrustningen stängas av. Montera alla skyddsplåtar igen innan utrustningen slås på.</p>
<p> ÎNȘTIINȚARE</p> <p>Instalarea și întreținerea trebuie să se efectueze de către personalul calificat.</p>	<p> OBS</p> <p>Installation och underhåll får endast utföras av kvalificerad personal.</p>
<p>CZ  NEBEZPEČÍ</p> <p>Nebezpečné napětí. Nebezpečí smrtelného nebo těžkého úrazu. Před zahájením prací na tomto zařízení odpojte a zajistěte veškeré přívody energie. Před opětovným připojením zařízení vraťte všechny kryty na svá místa.</p>	<p>SL  NEVARNOST</p> <p>Nevarna napetost. Nevarnost za življenje ali nevarnost hudih poškodb. Izklopite in prekinite celotno napajanje naprave, preden na njej opravljate dela. Preden napajanje znova vklopite, namestite vse pokrove.</p>
<p> POZNÁMKA</p> <p>Instalaci a údržbu musí provádět kvalifikovaní pracovníci.</p>	<p> OPOMBA</p> <p>Namestitev in vzdrževanje mora opraviti usposobljeno osebje.</p>
<p>SK  NEBEZPEČENSTVO</p> <p>Nebezpečné napätie. Nebezpečenstvo ohrozenia života alebo vzniku ťažkých zranení. Pred prácou na zariadení vypnite a zaistite všetky napájacie prípojky tohto zariadenia. Pred zapnutím napájania tohto zariadenia najprv nasad'te späť všetky kryty.</p>	<p>HU  VESZÉLY</p> <p>Veszélyes feszültség. Életveszély vagy súlyos sérülésveszély. Mielőtt bármilyen munkavégzést kezd az eszközön, az áramellátást le kell kapcsolni, és véletlen bekapcsolás elleni védelemmel kell ellátni. Az áramellátás visszakapcsolása előtt minden burkolatot vissza kell helyezni.</p>
<p> UPOZORNENIE</p> <p>Inštaláciu a údržbu musí vykonávať kvalifikovaný personál.</p>	<p> MEGJEGYZÉS</p> <p>A telepítést és a karbantartást kizárólag szakképzett személyzet végezheti.</p>



Required tools / Notwendige Werkzeuge / Outils nécessaires / Herramientas requeridas / 必要工具



1.5 mm
2.0 mm
2.5 mm
3.0 mm



PZ 1
PZ 2



3 mm [1/8"]
4.5 mm [3/16"]
5.5 mm [7/32"]
10 mm [13/32"]



cal. ISO 6789



2 mm
[0.08 in]



Contents / Lieferumfang / Etendue de la livraison / Contenido / 供货范围



8UD1721-0AB11
8UD1721-0AB15
8UD1731-0AB11
8UD1731-0AB15
8UD1721-0AC11
8UD1721-0AC15
8UD1731-0AC11
8UD1731-0AC15

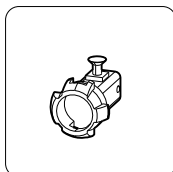

8UD1721-0AB21
8UD1721-0AB25
8UD1731-0AB21
8UD1731-0AB25
8UD1721-0AC21
8UD1721-0AC25
8UD1731-0AC21
8UD1731-0AC25

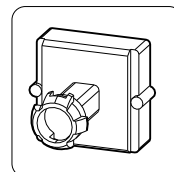
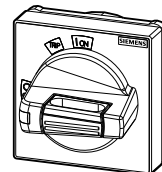

8UD1741-0AB11
8UD1741-0AB15
8UD1741-0AC11
8UD1741-0AC15

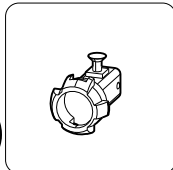
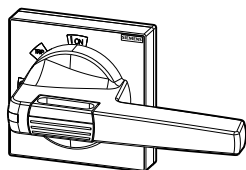

8UD1741-0AB21
8UD1741-0AB25
8UD1741-0AC21
8UD1741-0AC25

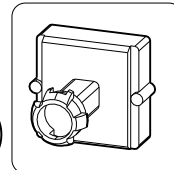
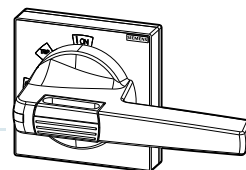

8UD1900-2HA00
8UD1900-4HA00

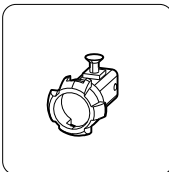

8UD1900-2GA00
8UD1900-4GA00

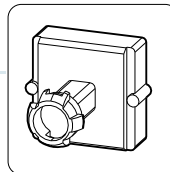

8UD1900-2WA00
8UD1900-4WA00
8UD1900-2WB00
8UD1900-4WB00

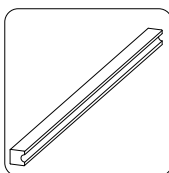

8UD1900-2DA00
8UD1900-4DA00

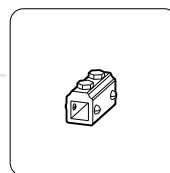



Assembly / Montage / Montage / Montaje / 安装



8UD1721-0A...
8UD1731-0A...

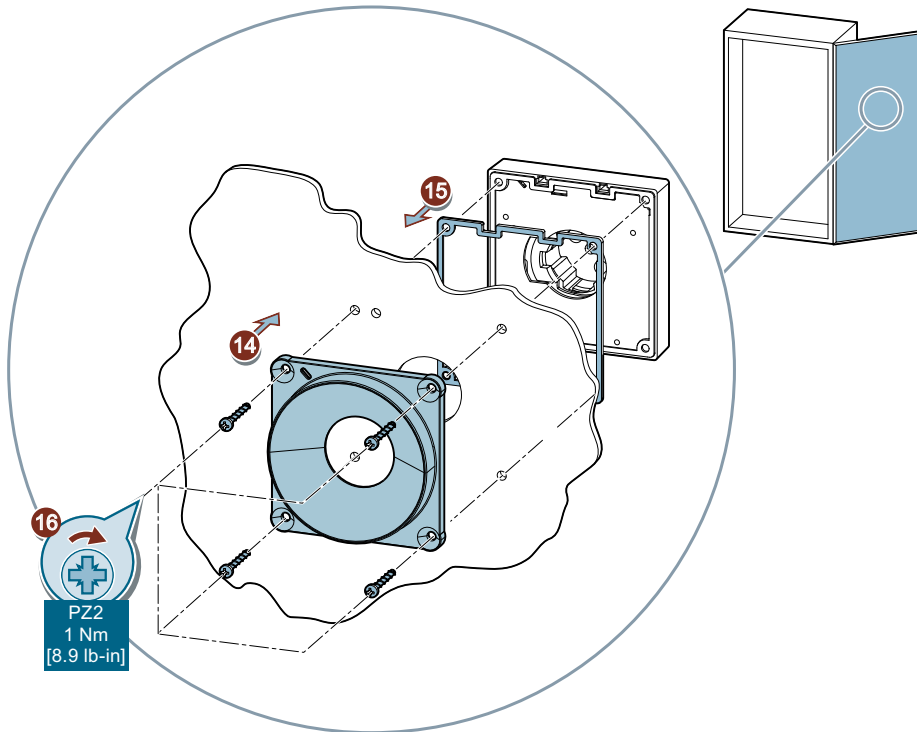
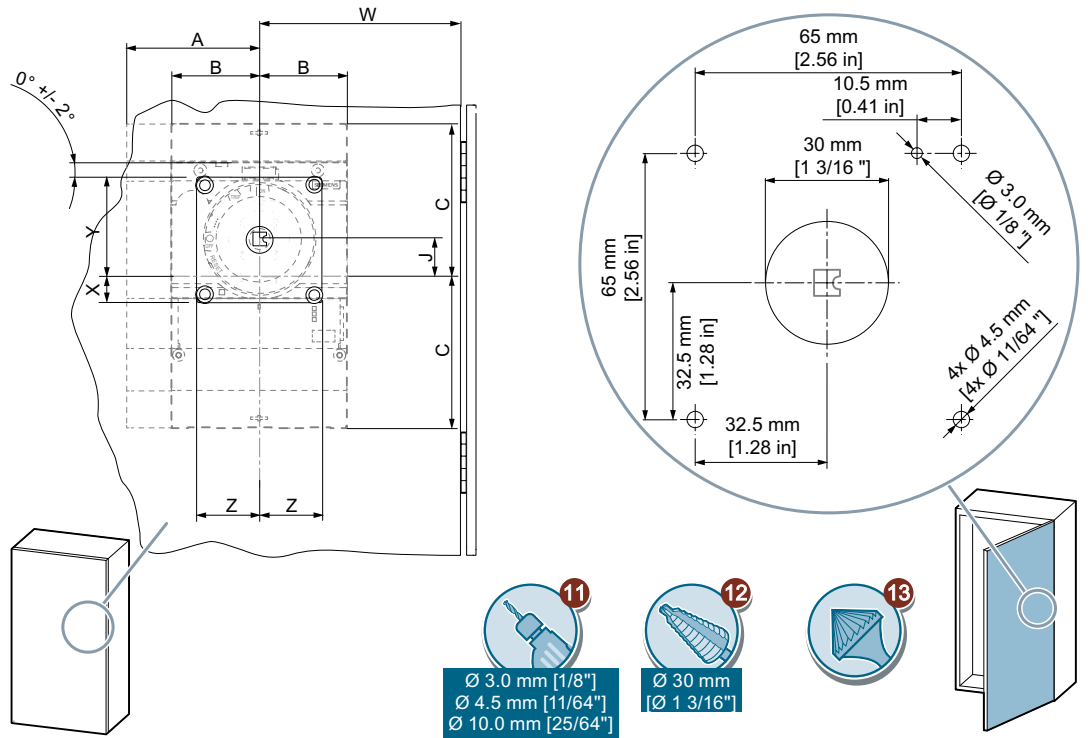



8UD1721-0A...
8UD1731-0A...

EN	Option
DE	Option
FR	Option
ES	Opción
IT	Opzione
PT	Opção
TR	Opşiyon
PY	Опция
PL	Opcja
中	选项

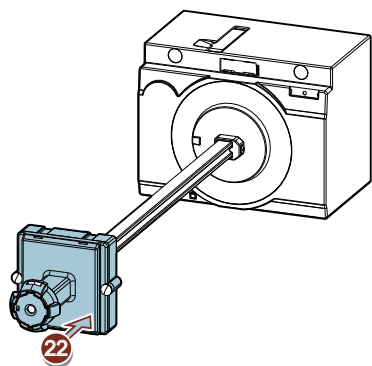
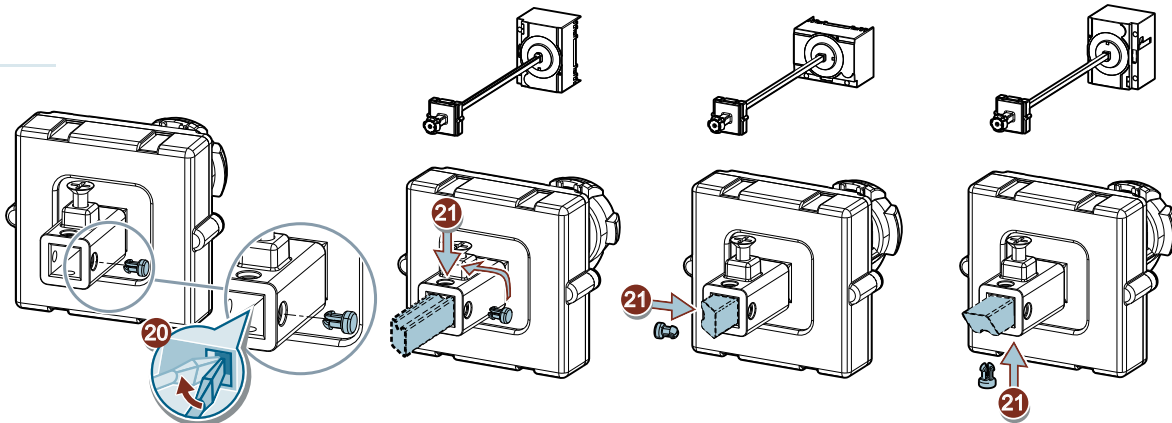

3VA9..7 - OFK2.

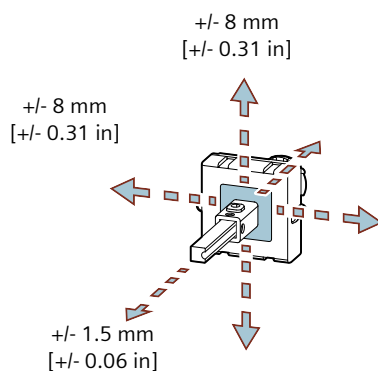

3VA9..7 - OFK61

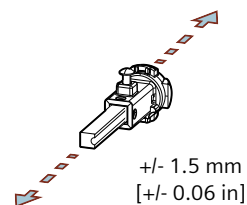

PZ2
2.5 Nm
[22.1 lb-in]

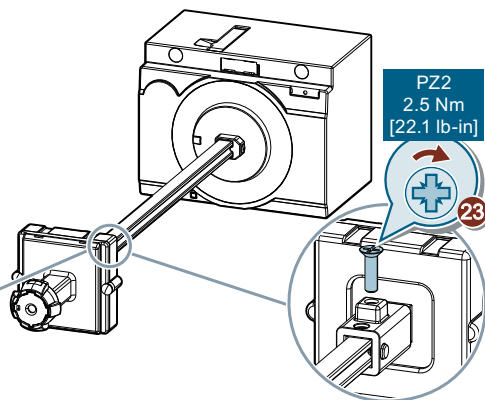
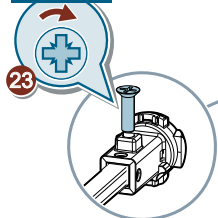

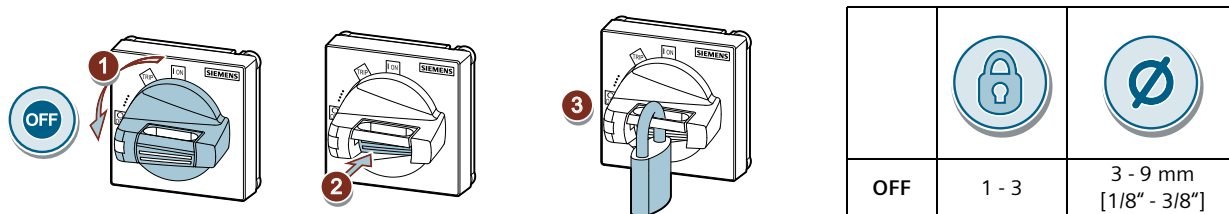

EN	Lock ON. This modification is not reversible. The protective function of the circuit breaker is not affected by locking in the ON position. In the event of a fault, the circuit breaker trips without restriction, but the rotary operating mechanism does not move into the trip position until after removal of the lock.
DE	Verriegelung in ON. Diese Modifikation ist nicht reversibel. Die Schutzfunktion der Leistungsschalter wird durch Verriegelung in der ON-Schaltstellung nicht beeinträchtigt. Im Fehlerfall löst der Leistungsschalter ohne Einschränkungen aus und der Drehantrieb bewegt sich erst nach Entfernen der Schlösser in die Schaltstellung Ausgelöst/Trip.
FR	Verrouillage ON. Cette modification est irréversible. La fonction de protection des disjoncteurs n'est pas altérée par le verrouillage sur la position de commutation ON. En cas de panne, le disjoncteur se déclenche sans aucune restriction et la commande rotative ne passe à la position déclenché/Trip qu'après le retrait des verrous.
ES	Bloqueo en ON. Esta modificación no es reversible. La función de protección del interruptor automático no es afectada por el bloqueo en la posición ON. En caso de defecto el interruptor se dispara sin restricciones, pero el accionamiento giratorio no se mueve a la posición "disparado" (Trip) hasta que se retire el bloqueo.
IT	Interblocco in posizione ON. Questa modifica non è reversibile. La funzione di protezione dell'interruttore automatico non è pregiudicata dall'interblocco in posizione di commutazione ON. In caso di sovraccarico o cortocircuito l'interruttore automatico interviene senza limitazioni e il comando rotativo si muove solo dopo la rimozione dei lucchetti nella posizione di commutazione Intervento/Trip.
PT	Bloqueio em ON. Esta alteração não é reversível. A função de proteção dos disjuntores de potência não é afetada pelo bloqueio na posição de comutação ON. Em caso de erro, o disjuntor de potência dispara sem limitações e o acionamento rotativo só se movimenta para a posição de comutação Disparado/Trip após a remoção das fechaduras.
TR	Kilit AÇIK. Modifikasyon geri alınmaz. Devre kesicinin koruma fonksiyonu, AÇIK anahtarlama konumunda kilitleme nedeniyle olumsuz etkilenmez. Hata durumunda, devre kesici kısıtlama olmadan tetiklenir ve döner tahrik, ancak kilitler çıkartıldıktan sonra Tetiklendi/Serbest bırakma anahtarlama konumuna gider.
PY	Блокировка в положении ВКЛ. Данная модификация не является реверсивной. Блокировка в положении ВКЛ не влияет на защитную функцию силового выключателя. В случае сбоя силовой выключатель срабатывает без ограничений, поворотный механизм двигается в положение сработал/выкл. только после снятия фиксаторов.
PL	Blokada w poz. ON Ta modyfikacja nie jest odwracalna. Funkcja ochronna wyłącznika mocy nie zostaje zakłócona wskutek blokady w pozycji ON. W przypadku wystąpienia awarii wyłącznik mocy zostaje wyzwolony bez ograniczeń i napęd obrotowy przełącza się do pozycji Wyzwolony/Trip dopiero po usunięciu klódek.
中	锁闭装置位于 ON 开关位置 该操作不可逆 通过将锁闭装置位于 ON 位置来使断路器的保护功能不受影响。故障情况下断路器可不受限制地触发，但旋转驱动在锁扣移除后才能向脱扣 / 跳闸开关位置转动。

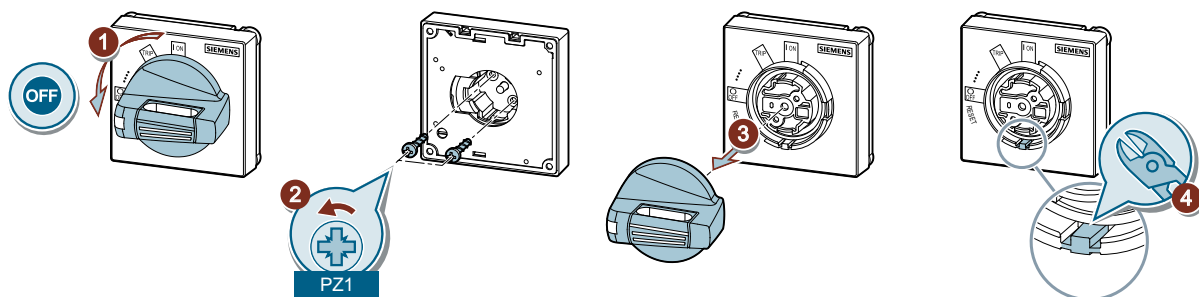



Information / Information / Informations / Información / 信息

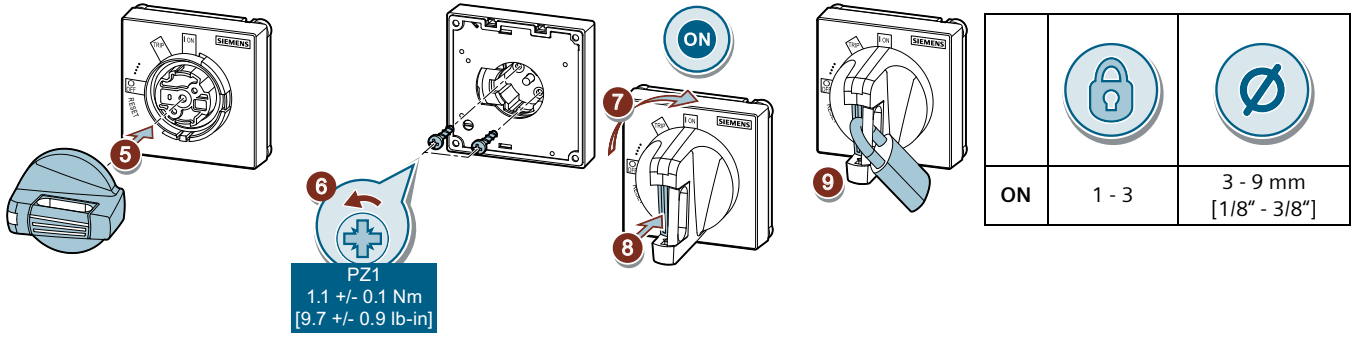

EN	Option
DE	Option
FR	Option
ES	Opción
IT	Opção
PT	Opzione
TR	Opsiyon
PY	Опция
PL	Opcja
中	选项



Test / Test / Test / Test / 测试



8UD1721-0AC..
8UD1731-0AC..

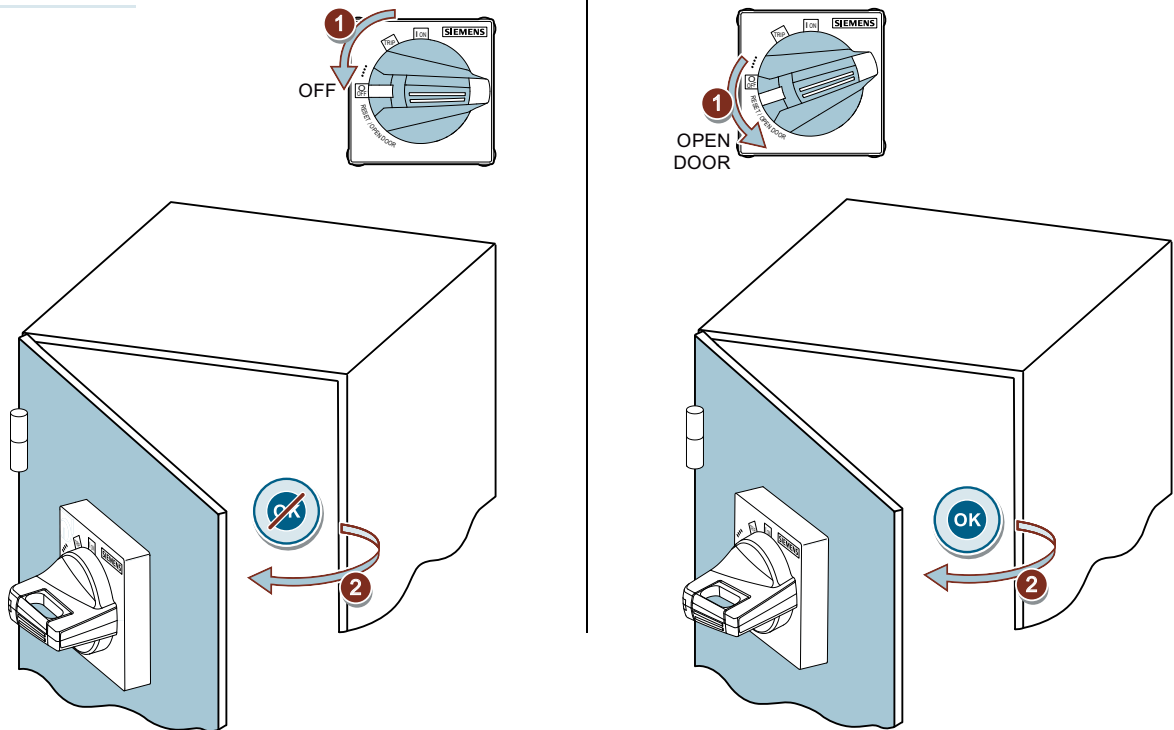



8UD1741-0A...

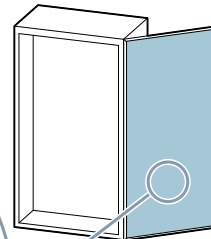
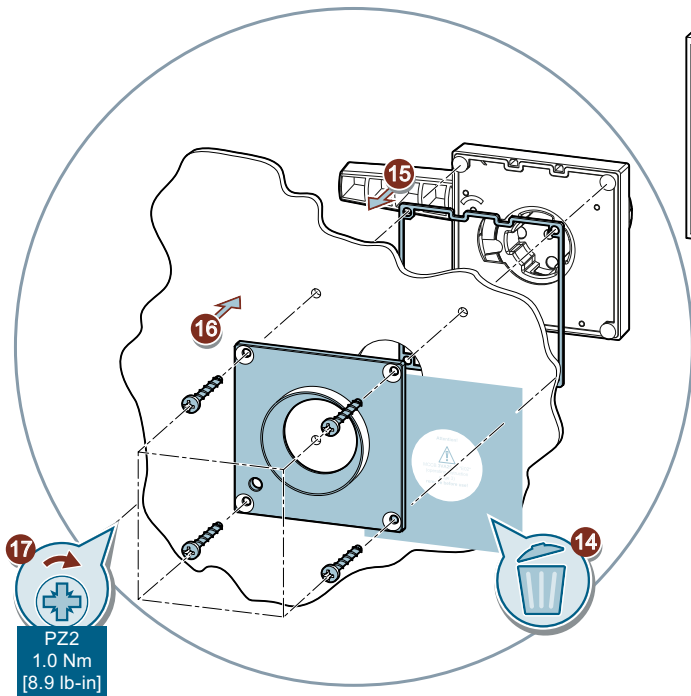
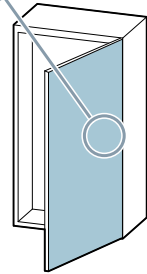
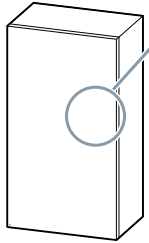
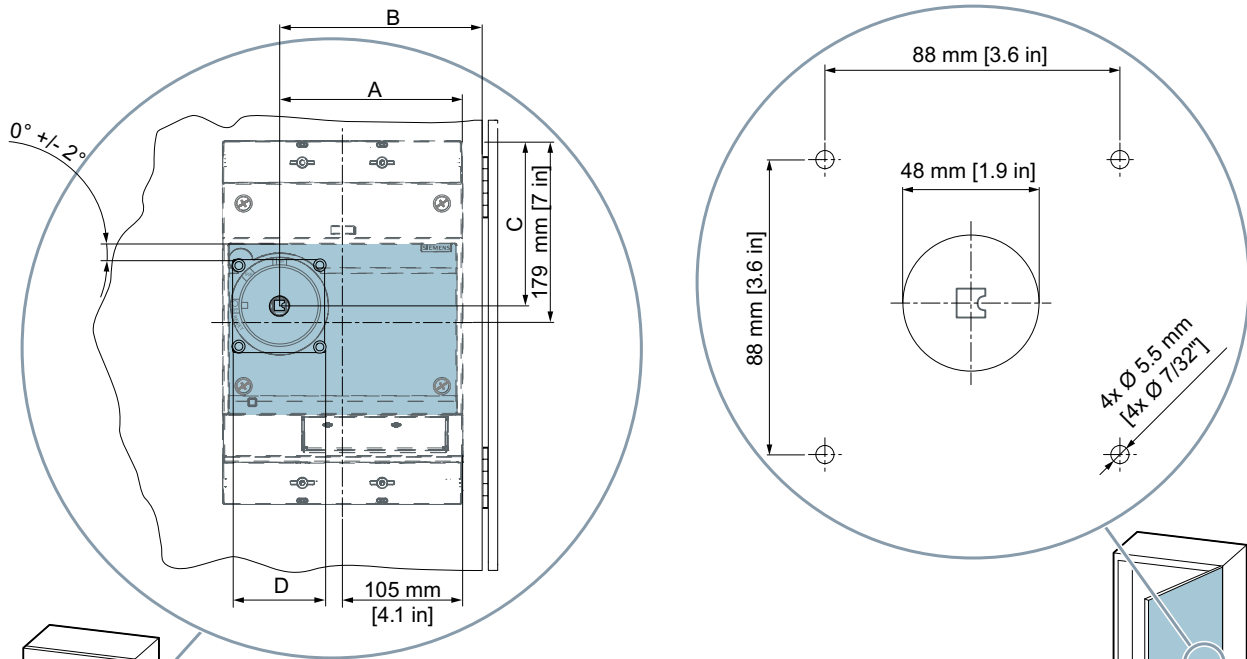



8UD1741-0A...

EN	Option
DE	Option
FR	Option
ES	Opción
IT	Opzione
PT	Opção
TR	Opzione
PY	Опция
PL	Opcja
中	选项

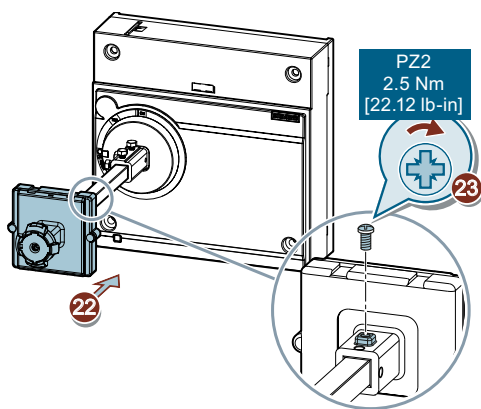
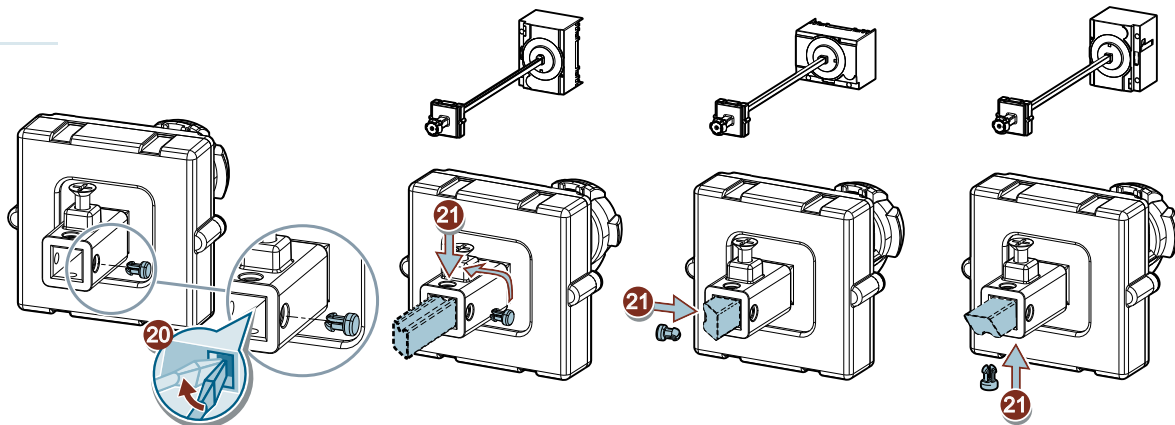

3VA9687-0FK2.

+/- 8 mm [+/- 0.3 in]

+/- 8 mm [+/- 0.3 in]

+/- 1.5 mm [+/- 0.06 in]

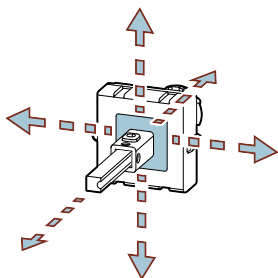

3VA9687-0FK61

+/- 1.5 mm [+/- 0.06 in]

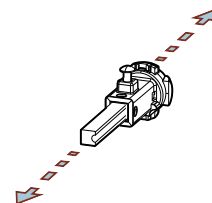



Information / Information / Informations / Información / 信息



EN	Deactivation of door interlock	PT	Desativar o travamento da porta
DE	Deaktivieren der Türverriegelung	TR	Kapı kilidini devre dışı bırakma
FR	Désactivation verrouillage de porte	PY	Отключение блокировки двери
ES	Desactivación del enclavamiento de puerta	PL	Dezaktywacja blokady drzwi
IT	Disattivazione del bloccoporta	中	禁用门联锁装置

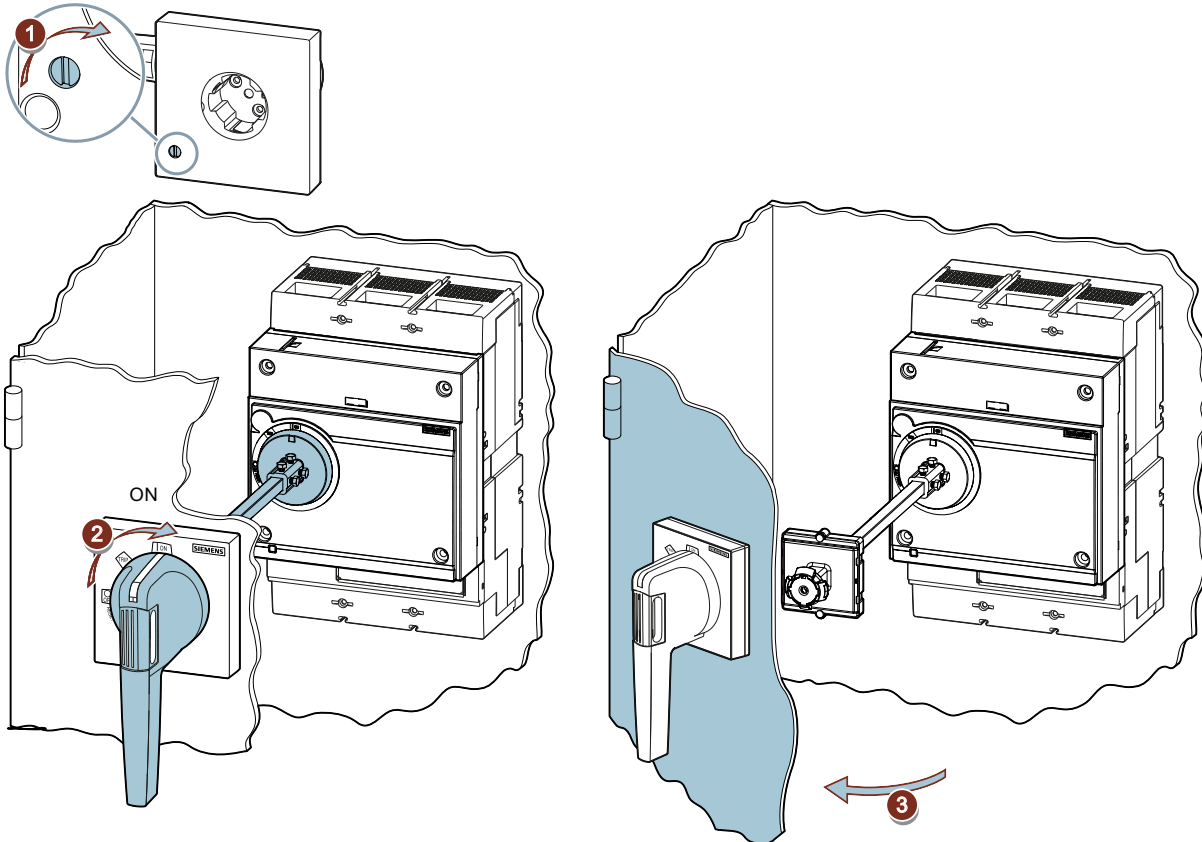

EN	Lock OFF.	PT	Travamento em OFF.
DE	Verriegelung in OFF.	TR	Kilit KAPALI.
FR	Verrouillage OFF.	PY	Блокировка в положении Выкл.
ES	Enclavamiento en posición OFF.	PL	Blokada w poł. OFF
IT	Interblocco in posizione OFF.	中	锁闭装置位于 OFF 开关位置。

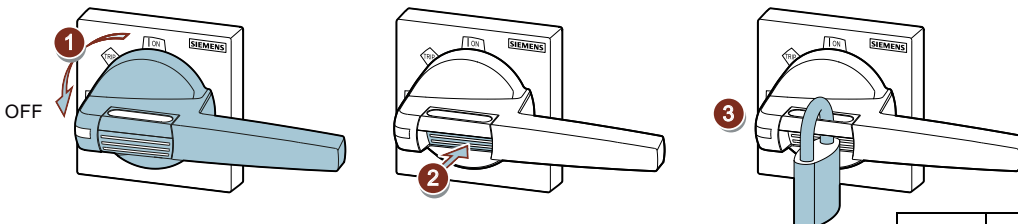

OFF	1 - 3	4.5 - 8.5 mm [1/4 - 3/8"]



Information / Information / Informations / Información / 信息



EN	Lock ON. This modification is not reversible. The protective function of the circuit breaker is not affected by locking in the ON position. In the event of a fault, the circuit breaker trips without restriction, but the rotary operating mechanism does not move into the trip position until after removal of the lock.
DE	Verriegelung in ON. Diese Modifikation ist nicht reversibel. Die Schutzfunktion der Leistungsschalter wird durch Verriegelung in der ON-Schaltstellung nicht beeinträchtigt. Im Fehlerfall löst der Leistungsschalter ohne Einschränkungen aus und der Drehantrieb bewegt sich erst nach Entfernen der Schlösser in die Schaltstellung Ausgelöst/Trip.
FR	Verrouillage ON. Cette modification est irréversible. La fonction de protection des disjoncteurs n'est pas altérée par le verrouillage sur la position de commutation ON. En cas de panne, le disjoncteur se déclenche sans aucune restriction et la commande rotative ne passe à la position déclenché/Trip qu'après le retrait des verrous.
ES	Bloqueo en ON. Esta modificación no es reversible. La función de protección del interruptor automático no es afectada por el bloqueo en la posición ON. En caso de defecto el interruptor se dispara sin restricciones, pero el accionamiento giratorio no se mueve a la posición "disparado" (Trip) hasta que se retire el bloqueo.
IT	Interblocco in posizione ON. Questa modifica non è reversibile. La funzione di protezione dell'interruttore automatico non è pregiudicata dall'interblocco in posizione di commutazione ON. In caso di sovraccarico o cortocircuito l'interruttore automatico interviene senza limitazioni e il comando rotativo si muove solo dopo la rimozione dei lucchetti nella posizione di commutazione Intervento/Trip.
PT	Bloqueio em ON. Esta alteração não é reversível. A função de proteção dos disjuntores de potência não é afetada pelo bloqueio na posição de comutação ON. Em caso de erro, o disjuntor de potência dispara sem limitações e o acionamento rotativo só se movimenta para a posição de comutação Disparado/Trip após a remoção das fechaduras.
TR	Kilit AÇIK. Modifikasyon geri alınamaz. Devre kesicinin koruma fonksiyonu, AÇIK anahtarlama konumunda kitleme nedeniyle olumsuz etkilenmez. Hata durumunda, devre kesici kısıtlama olmadan tetiklenir ve döner tahrik, ancak kilitler çıkartıldıktan sonra Tetiklendi/Serbest bırakma anahtarlama konumuna gider.
PY	Блокировка в положении ВКЛ. Данная модификация не является реверсивной. Блокировка в положении ВКЛ не влияет на защитную функцию силового выключателя. В случае сбоя силовой выключатель срабатывает без ограничений, поворотный механизм двигается в положение сработал/выкл. только после снятия фиксаторов.
PL	Blokada w poz. ON Ta modyfikacja nie jest odwracalna. Funkcja ochronna wyłącznika mocy nie zostaje zakłócona wskutek blokady w pozycji ON. W przypadku wystąpienia awarii wyłącznik mocy zostaje wyzwolony bez ograniczeń i napęd obrotowy przelacza się do pozycji Wyzwolony/Trip dopiero po usunięciu klódek.
中	锁闭装置位于 ON 开关位置 该操作不可逆 通过将锁闭装置位于 ON 位置来使断路器的保护功能不受影响。故障情况下断路器可不受限制地触发，但旋转驱动在锁扣移除后才能向脱扣 / 跳闸开关位置转动。

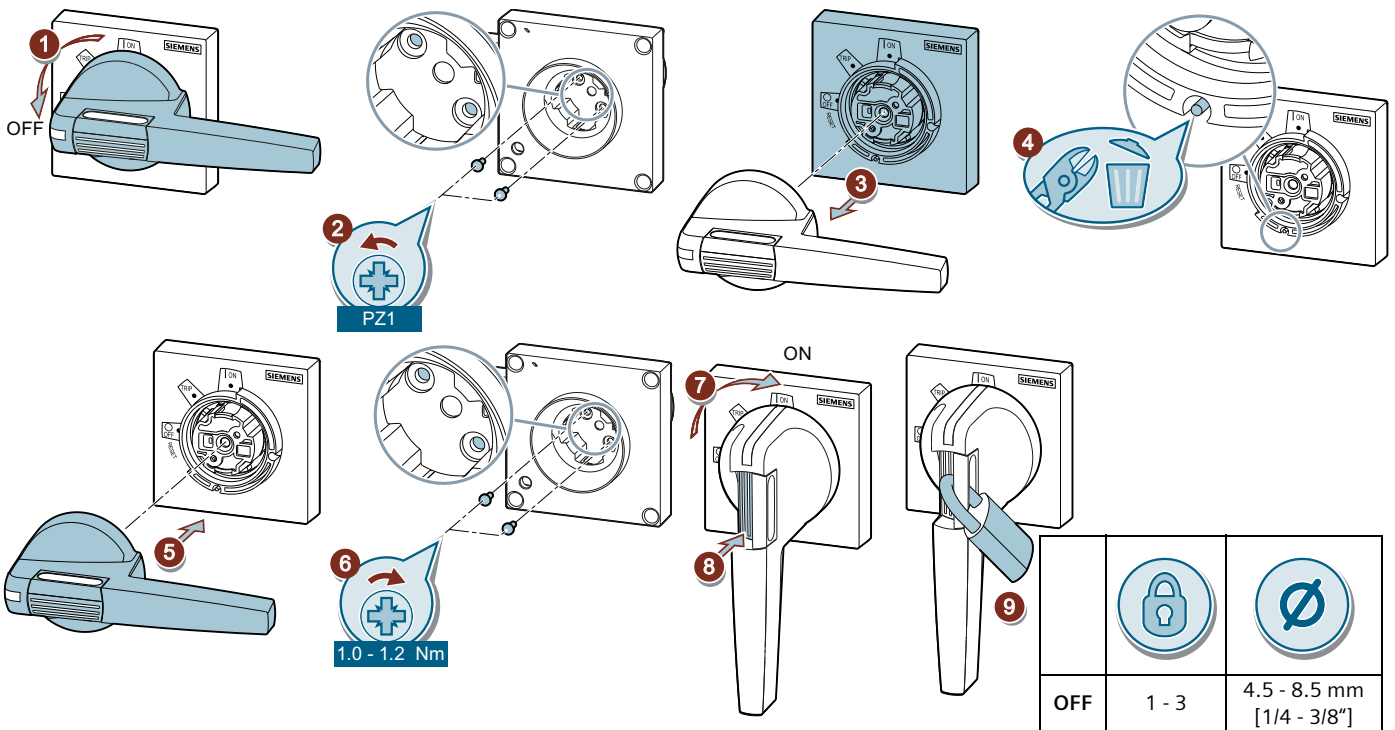



Information / Information / Informations / Información / 信息

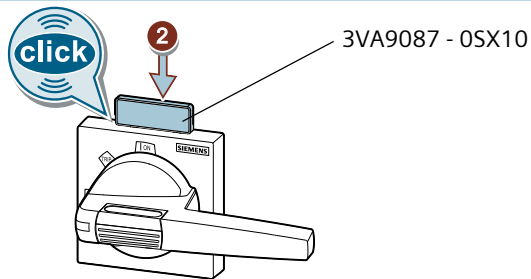
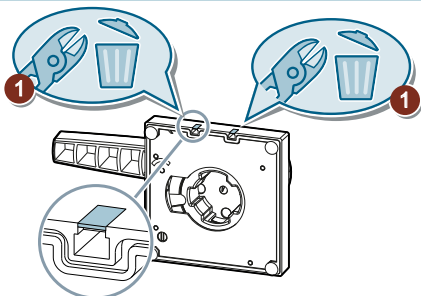

Assembly / Montage / Montage / Montaje / 安装



8UD1900-2HA00
 8UD1900-4HA00
 8UD1900-2GA00
 8UD1900-4GA00

8UD1900-2W.00
 8UD1900-4W.00
 8UD1900-2W.00
 8UD1900-4W.00

8UD1900-

+/- 8 mm [+/- 0.3 in]

+/- 8 mm [+/- 0.3 in]

+/- 1.5 mm [+/- 0.06 in]

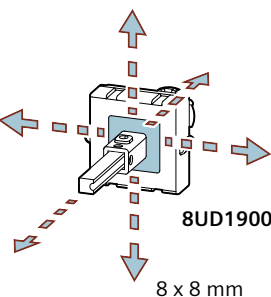

8UD1900-2W.00

8 x 8 mm

8UD1900-

+/- 1.5 mm [+/- 0.06 in]

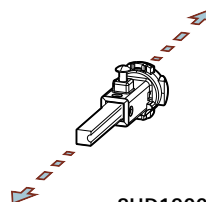

8UD1900-2W.00

8UD1900-

+/- 8 mm [+/- 0.3 in]

+/- 8 mm [+/- 0.3 in]

+/- 1.5 mm [+/- 0.06 in]

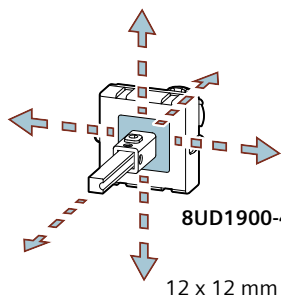

8UD1900-4W.00

12 x 12 mm

8UD1900-

+/- 1.5 mm [+/- 0.06 in]

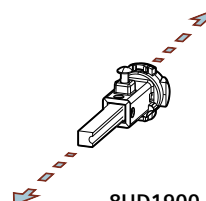

8UD1900-4W.00

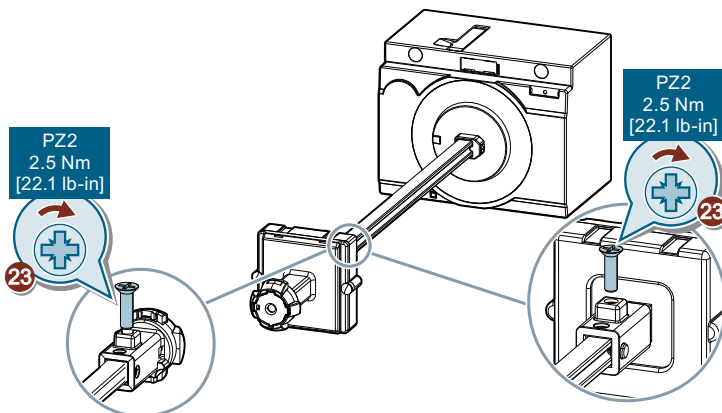

PZ2
2.5 Nm
[22.1 lb-in]

PZ2
2.5 Nm
[22.1 lb-in]

23

23



EN

⚠ DANGER

Hazardous voltage. Will cause death or serious injury. Turn off and lock out all power supplying this device before working on this device. Replace all covers before power supplying this device is turned on.

ES

⚠ PELIGRO

Tensión peligrosa. Puede causar la muerte o lesiones graves. Antes de trabajar en este dispositivo, desconecte y bloquee todas las fuentes que lo alimentan eléctricamente. Recoloque todas las cubiertas antes de volver a conectar la alimentación eléctrica para este dispositivo.

FR

⚠ DANGER

Tension électrique dangereuse. Danger de mort ou risque de blessures graves. Avant d'intervenir sur l'appareil, couper toutes les sources de tension et les consigner contre la refermeture. Remettre en place tous les couvercles avant de remettre l'appareil sous tension.



Assembly / Montage / Montage / Montaje / 安装



8UD1900-2DA00
8UD1900-2W.00

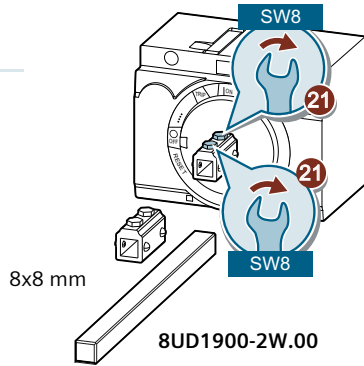

8UD1900-4DA00
8UD1900-4W.00

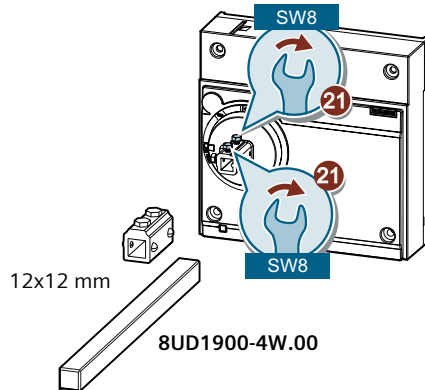

EN

NOTICE

These instructions do not purport to cover all details or variations in equipment, or to provide for every possible contingency in connection with installation, operation, or maintenance. Should additional information be desired, please contact the local Siemens sales office. The contents of this instruction manual shall not become part of or modify any prior or existing agreement, commitment, or relationship. The sales contract contains the entire obligation of Siemens. The warranty contained in the contract between the parties is the sole warranty of Siemens. Any statements contained herein do not create new warranties or modify the existing warranty.

Trademarks - Unless otherwise noted, all names identified by ® are registered trademarks of Siemens AG or Siemens Industry, Inc. The remaining trademarks in this publication may be trademarks whose use by third parties for their own purposes could violate the rights of the owner.