

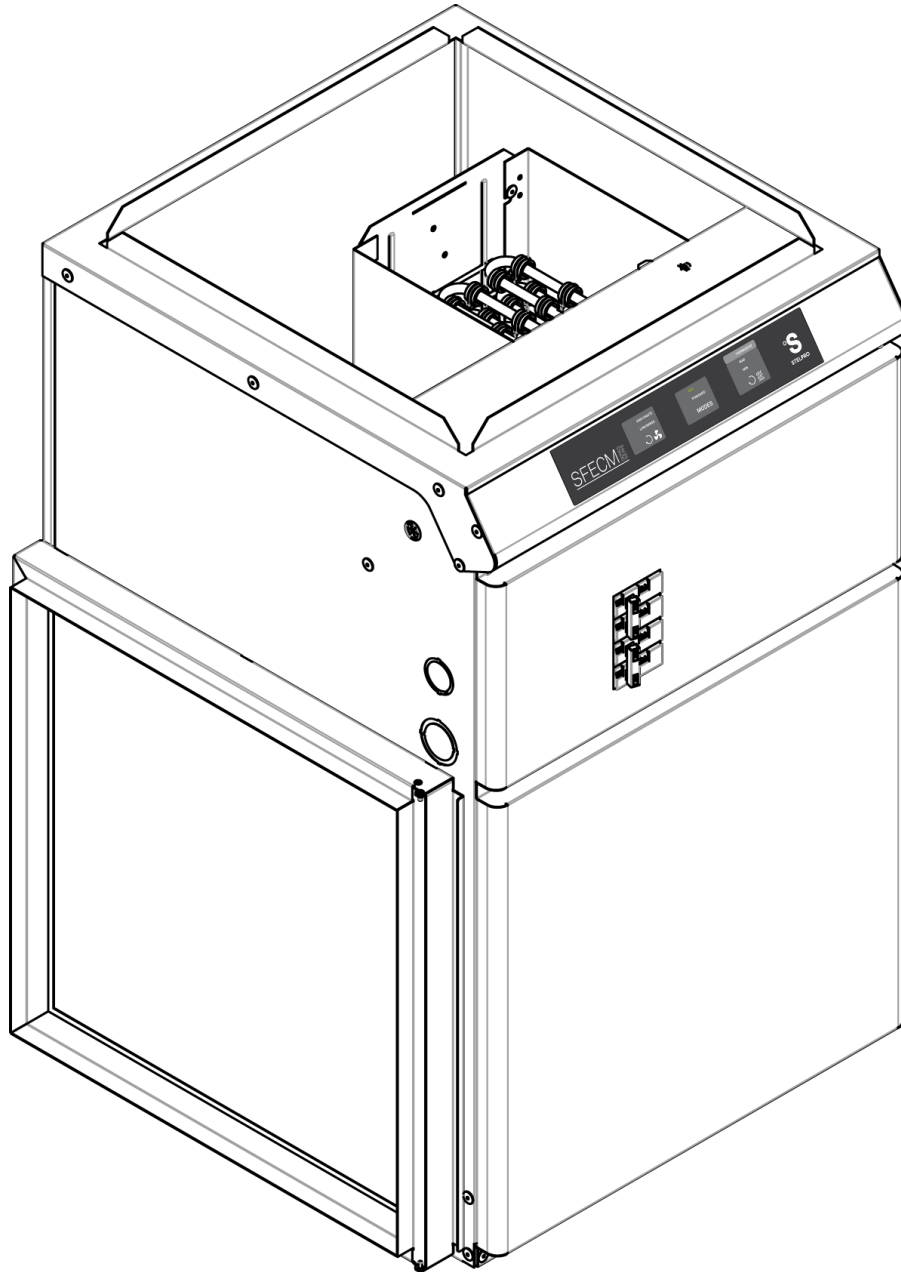

# USER'S GUIDE

## SFECM SERIES ELECTRIC FURNACE

REPLACEMENT COMPONENT LIST INCLUDED



This unit complies with the CSA and UL standards



## THE FURNACE



This unit is approved according to the Canadian and American manufacturing standards.

**This section must be read carefully by the installer.  
The installer must also read the user's guide since it contains other important information.**



## WARNING

Before installing and operating this product, the user and/or installer must read, understand and follow these instructions and keep them handy for future reference. If these instructions are not followed, the warranty will be considered null and void and the manufacturer deems no further responsibility for this product.

This product must be installed by a qualified person and connected by a **certified electrician**, according to the **electrical and building codes** effective in your region.

The following instructions must be adhered to in order to avoid personal injuries or property damages, serious injuries and potentially fatal electric shocks.

Make sure that all screws and electrical terminal connections are tightly secured before operating the unit in case they would have loosened during transportation.

Protect the heating unit with the appropriate circuit breaker or fuse, in accordance with the nameplate.

Make sure the line voltage (volt) is consistent with that indicated on the unit's nameplate.

This unit must be **grounded**.

Switch off the power at the circuit breaker/fuse before installing, repairing and cleaning the unit.

Make sure the unit is appropriate for the intended use (if needed, refer to the product catalog or a representative).

If the unit's capacity is insufficient for the size of the house, it will be in operation continuously, and may become prematurely defective.

**Respect distances and positions** indicated in the installation section.

If the installer or the user modifies the unit, they will be held responsible for any damage resulting from this modification, and the CSA certification could be void.

This unit must not come into contact with a water source and must be protected from splashes (e.g. a wet mop). Do not use it if any part has been immersed. Moreover, do not turn it on or off when standing in water or if your hands are wet.

When cutting a piece of steel for the installation of the return duct, do not damage electrical wiring of the unit.

Because this unit is hot when in use, it may pose risks even in normal operation. Therefore, be **careful** and **responsible** when using it. To avoid burns, do not let bare skin touch hot surfaces. Let the unit cool down for a few minutes before handling it (it stays warm for some time after shut-down).

Never block air vents. This obstruction could lead to overheating, which could result in a fire.

Do not insert or allow foreign objects to enter any air vent as this may cause electric shocks, fires, or damages to the unit.

This unit has hot and arcing or sparking parts inside. It is not designed to be used or stored in wet areas or areas containing flammable liquids, combustible materials or corrosive, abrasive, chemical, explosive and flammable substances such as, but not limited to, gasoline, paint, chlorine and cleaning products.

Some areas are dustier than others. Thus, it is the user's responsibility to evaluate if the **filter must be changed** based on it. Accumulated dirt can lead to a component malfunction or discoloration (yellowing). It may cause a fire hazard if not installed and maintained in accordance with these instructions.

Thermal protection activation indicates that the unit has been subjected to abnormal operating conditions. If the thermal protection remains activated or activates and deactivates repeatedly, it is recommended that a qualified electrician or a certified repair centre examine the unit in order to make sure it is not damaged. (Refer to the limited warranty).

If the unit is damaged or defective, cut off power supply at circuit breaker/fuse and call a certified repair centre. (Refer to the limited warranty).

Label all wires prior to disconnection when servicing controls. Wiring errors can cause improper and dangerous operation.



**Note:** When a part of the product specification must be changed to improve operability or other functions, priority is given to the product specification itself. In such instances, the instruction manual may not entirely match all the functions of the actual product. Therefore, the actual product and packaging, as well as the name and illustration, may differ from the manual.

# ELECTRICAL CONNECTION OF AN ELECTRONIC FILTER AND A HUMIDIFIER

A humidifier and an electronic filter can be controlled directly from the furnace. There is a terminal block for this purpose in the furnace as shown here in the diagram. The terminal block is connected to an internal relay that activates the auxiliary devices when the blower of the furnace is in operation.

## TYPICAL FURNACE TO AUXILIARY DEVICE CONNECTIONS

\* R terminal: 1A maximum

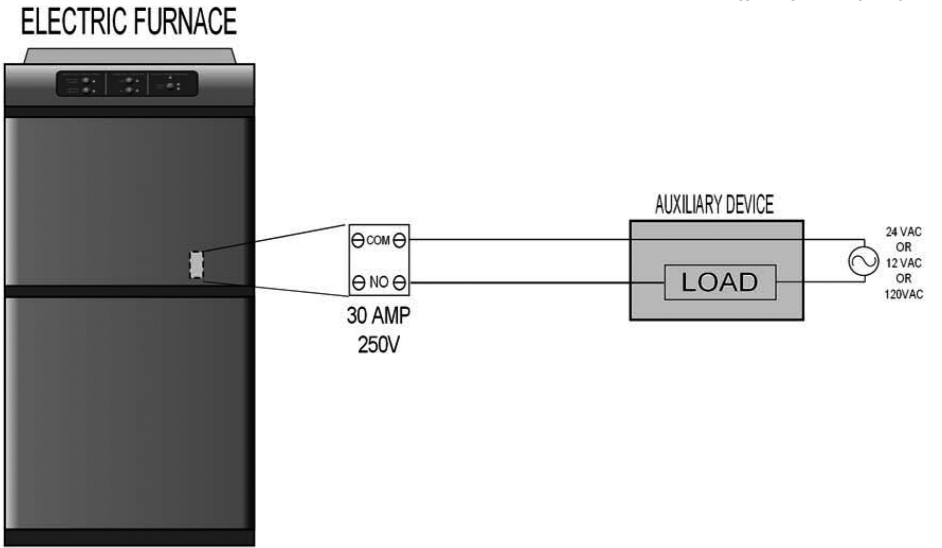

## CONTROL PANEL

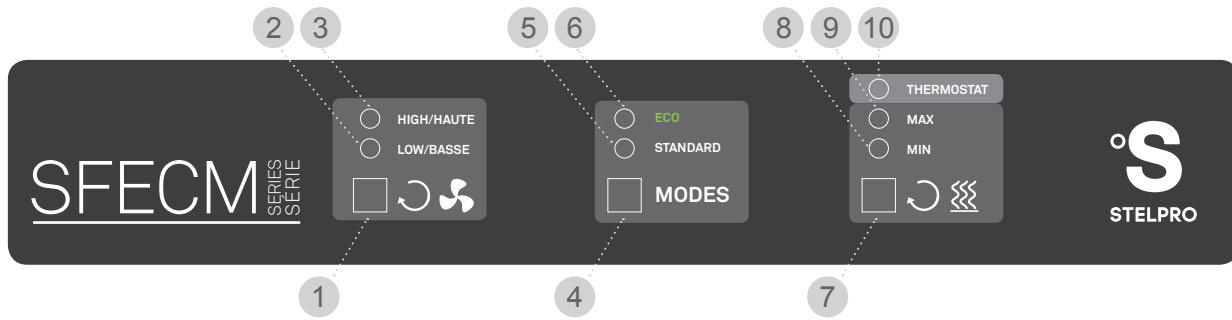

### LEGEND

- CONTINUOUS VENTILATION** button: Allows the selection of the high or low speed continuous ventilation mode.
- LOW SPEED CONTINUOUS VENTILATION** green LED: Indicates that the low speed continuous ventilation mode is activated.
- HIGH SPEED CONTINUOUS VENTILATION** green LED: Indicates that the high speed continuous ventilation mode is activated.
- MODE** button: Allows the selection of the Standard or Eco mode.
- STANDARD MODE** green LED: Indicates Standard mode is activated.
- ECO MODE** green LED: Indicates that the Eco mode is activated.
- CONTINUOUS HEATING** button: Allows the selection of the maximum or minimum continuous heating mode.
- MIN CONTINUOUS HEATING** green LED: Indicates that the minimum of heating capacity is activated.
- MAX CONTINUOUS HEATING** green LED: Indicates that the maximum of continuous heating mode is activated.
- THERMOSTAT** yellow LED: Indicates that the furnace is receiving a heating demand from the thermostat.

## HEATING DEMAND

### ONE-STAGE THERMOSTAT

**W1-** The thermostat closes the R-W1 circuit, which activates 100% of the heating sequence. The blower starts up at medium speed and the furnace elements are activated one by one to reach the adjustable temperature limit set on the potentiometer of the furnace control card.

If there is still a W1 heating demand after 30 minutes, the heating sequence continues as per the W2 sequence.

**Or W2-** If there is still a W1 heating demand after 30 minutes, the sequence continues as follows: the blower switches to the medium speed and all the furnace elements are activated one by one (100% heating). The plenum temperature is still limited by the potentiometer of the control card.

### TWO-STAGE THERMOSTAT

The control card of the furnace auto-detects the two stages of the thermostat.

**W1-** The thermostat closes the R-W1 circuit, which activates the first stage of the heating sequence ( $\pm 50\%$  heating). The blower starts up at low speed and the furnace elements are activated one by one to reach the adjustable temperature limit set by the potentiometer on the furnace control card.

If there is still a W1 heating demand after 30 minutes, the heating sequence continues as per the W2 sequence.

**And/Or W2-** If the thermostat closes the R-W2 circuit, the sequence continues as follows: the blower switches to the medium speed and all the furnace elements are activated one by one (100% heating). The plenum temperature is still limited by the potentiometer of the control card.

### HEATING DEMAND, STANDARD MODE (WITH T-STAT INTELLIGENCE)

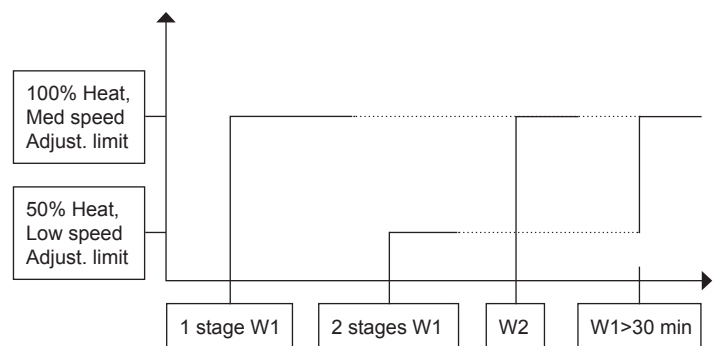

Activation of relays, 3-sec. interval

## CONTINUOUS VENTILATION

Two ventilation speeds can be selected on the furnace control panel: LOW SPEED CONTINUOUS VENTILATION or HIGH SPEED CONTINUOUS VENTILATION. The user can select the ventilation speed by pressing the button located on the left side of the control panel (item #1 in the control panel picture).

The SFECM series allows to adjust the continuous ventilation airflows independently from the ventilation airflow in heating mode. Note that it also allows airflows as low as 300 cfm in continuous ventilation. This reduces ventilation noises considerably.

## CONTINUOUS HEATING

The continuous heating option allows one or two heating elements to operate continuously. The user can select the minimum (one element) or maximum (two elements) continuous heating by pressing the button located on the right side of the control panel (item #7 in the control panel picture). Please note that for model #1021, the minimum and maximum continuous heating are the same (one element). The continuous heating mode is useful from the beginning to the end of the heating season since it reduces temperature variations into the house. If the minimum or maximum continuous heating option is activated by the user, the furnace will deactivate it when the heating season ends (more than two hours without any heating demand). Moreover, it will reactivate it when a new heating season begins. Note that the pilot light indicating the heating option will blink if the furnace deactivates this option because the heating season is over. This indicates that the continuous heating will be activated again at the start of the next heating season.

## AIR CONDITIONING

The furnace supplies the necessary 24V power for the thermostat relay (R-Y terminals) to control the air-conditioner compressor relay. When the R-Y terminals are activated, the blower starts-up at high speed. See the connection diagram.

## HEAT PUMP

If a heat pump is installed in your central heating system, the Stelpro electric furnace offers the installer two types of installations: type "A" or type "B". Installation "A" must be selected when the heat pump is installed **A**fter the furnace (air supply), and installation "B" must be selected when the heat pump is installed **B**efore the furnace (air return), as shown in the next picture. Once again, when the R-Y terminals are activated, the blower starts-up at high speed.

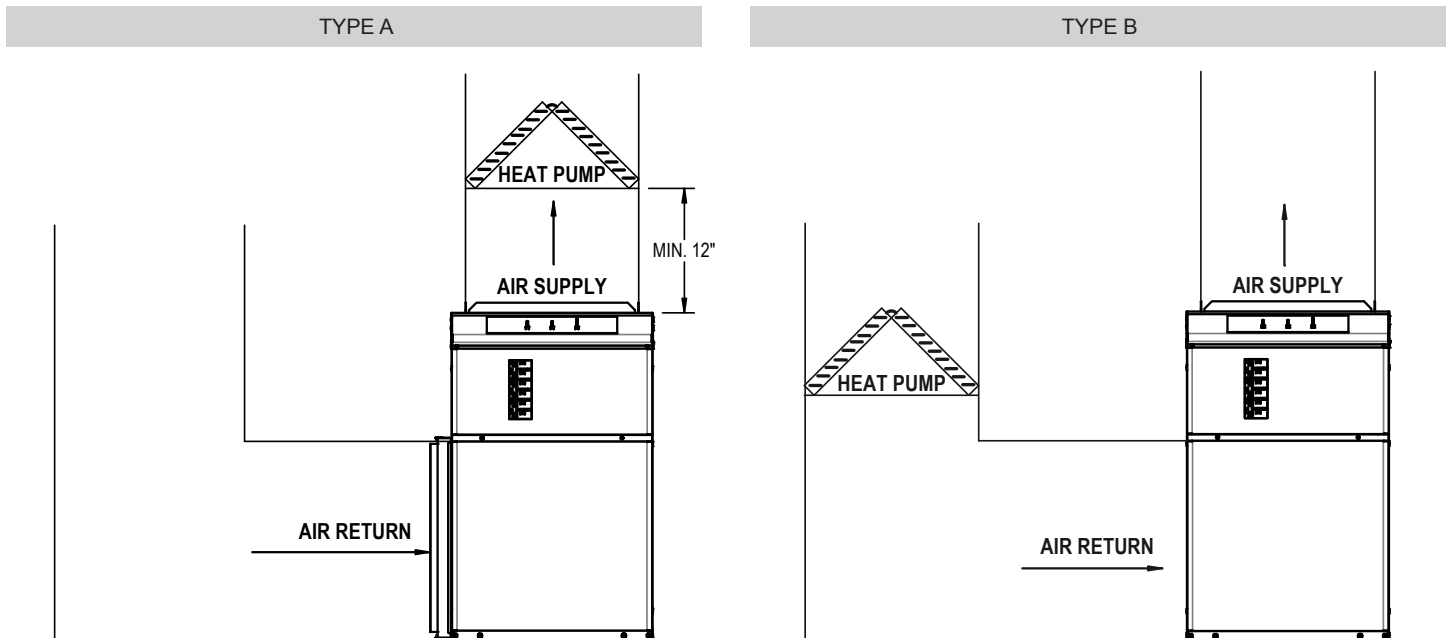

**TYPE A: HEAT PUMP OR AIR CONDITIONING**

For type "A" installation, whenever the heat pump is in operation (Y demand from the thermostat), no electric heating will be supplied by the furnace. The table below explains the functions of the furnace when installed as type "A".

		INPUTS						HEATING		LIMIT TEMP.	FAN		
		1 STAGE		2 STAGES		Y	O/B	50%	100%	ADJ.	HIGH	MED	LOW
		G	W1	W1	W2								
HEATING DEMAND	1	0	0	0	0	X						ON	
	X	1	-	0	0	X		ON	•		ON		
	X	-	1	0	0	X	ON		•			ON	
	X	X	X	1	0	X		ON	•		ON		
(#1) FACTORY SET	TYPE A (AFTER)	X	X	X	X	1	X				ON		

**TYPE B: HEAT PUMP ONLY**

If type "B" installation is selected, the installer can select the active side of the reversible valve, either "O" for priority heating or "B" for priority cooling. Type "A" is factory set, but the installer can change the type of installation at the furnace start up. Before powering the furnace, the installer must press one of the three buttons on the control panel and then simultaneously put the breaker ON. The button located on the left side of the control panel (item #1 in the control panel picture) is for type "A"; the button located in the middle of the control panel (item #4 in the control panel picture) is for type "B" with the "O" side of the reversible valve active; and the button located on the right side of the control panel (item #7 in the control panel picture) is for type "B" with the "B" side of the reversible valve active. The pilot light located just above the selected button will flash to indicate which installation has been programmed.

The heat pump can operate all year and allows the user to make energy savings due to the plenum temperature regulation function (exclusive to Stelpro). This function ensures a constant temperature into the plenum and the ducts. When it is cold, the heating capacity of the heat pump is reduced. For type "B" installation, the furnace will compensate for the capacity loss of the heat pump. Even when the defrosting mode of the heat pump is activated and begins to cool the air, the furnace will quickly increase the heating capacity in order to offset the cooling effect caused by the defrosting mode of the heat pump.

		INPUTS						HEATING		LIMIT TEMP.	FAN		
		1 STAGE		2 STAGES		Y	O/B	50%	100%	ADJ.	HIGH	MED	LOW
		G	W1	W1	W2								
HEATING DEMAND	1	0	0	0	0	X						ON	
	X	1	-	0	0	X		ON	•		ON		
	X	-	1	0	0	X	ON		•			ON	
	X	X	X	1	0	X		ON	•		ON		
(#2) Type B (Before)	X	X	X	X	1	1				ON		"O" active (Priority heating)	
	X	X	X	X	1	0		ON	•	ON			
(#3)	X	X	X	X	1	1		ON	•	ON		"B" active (Priority cooling)	
	X	X	X	X	1	0				ON			

TYPE "B", STANDARD MODE WITH TEMPERATURE COMPENSATION (WITH T-STAT INTELLIGENCE)

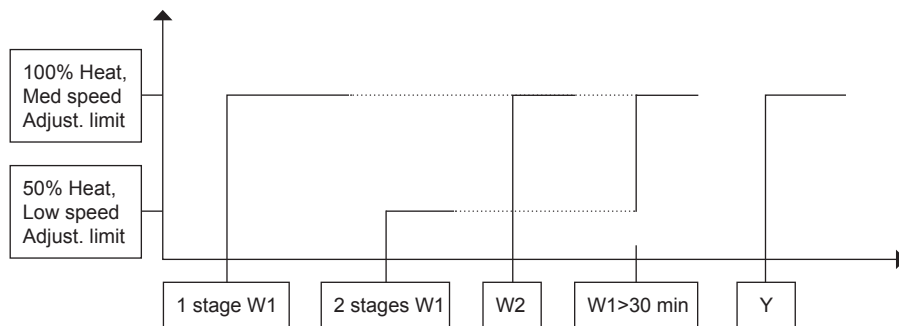

Activation of relays, 3-sec. interval

## MODES

The user can select two different heating modes by pressing the button located in the middle of the control panel (item #4 in the control panel picture). The two modes affect the heating demand and the functions when used with the heat pump and the STANDARD mode described previously. When ECO mode is selected, the heating sequence is longer than STANDARD and the heating power will ramp-up to 50% heating for five (5) minutes. If a heating demand lasts 30 minutes, a second sequence of five (5) minutes activates a ramp-up of the elements to 100% heating at medium speed.

HEATING DEMAND, ECO MODE, W1 DEMAND (WITH FURNACE INTELLIGENCE)

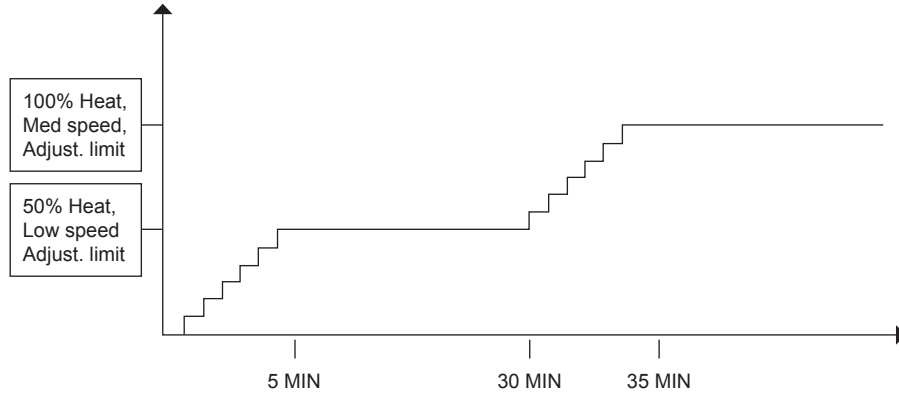

For a two-stage thermostat, when the W2 is in demand, the furnace waits another five (5) minutes before ramping-up for five (5) minutes until 100% of heating capacity is reached.

HEATING DEMAND, ECO MODE, W2 DEMAND (WITH FURNACE INTELLIGENCE)

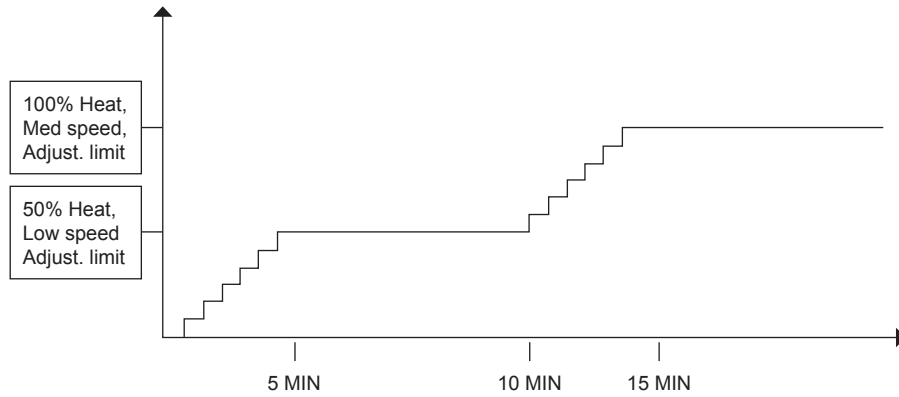

Also, the temperature compensation option explained previously in installation type "B" does not operate in ECO mode. Thus, whenever the heat pump is activated (Y demand), no electric heating will be supplied by the furnace.

## AIRFLOW SETTINGS

The SFECM furnace is equipped with an efficient ECM motor that can maintain constant airflow regardless of the static pressure variation in the ducts. It also ensures an easy setting of the airflows related to each operation mode of the furnace blower. The blower has four adjustments:

A potentiometer allowing to adjust the airflow corresponds to each of these four modes. The potentiometers are located on the furnace control card. The adjustment scales vary from one model to the other according to the capacity of the unit and are represented on the table below. The airflows can be adjusted while the furnace is running. To adjust airflows, you must set the potentiometers to the desired values.

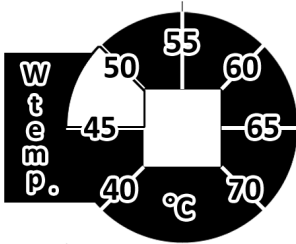

1. Heating temperature

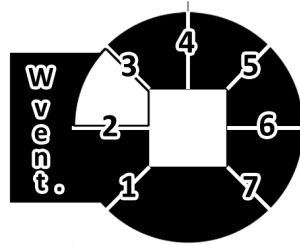

2. Heating ventilation

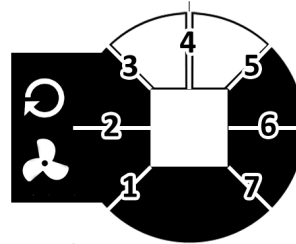

3. Continuous ventilation

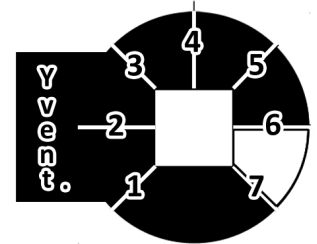

4. Y ventilation

TABLEAU D'AJUSTEMENT DES DÉBITS D'AIR  
AIRFLOW SETTINGS TABLE

MODÈLE / MODEL 1021	CONT. VENT.		W VENT.		Y VENT.
	LOW	HIGH	W1	W2	
1	300	700	300	700	400
2	366	766	400	800	575
3	433	833	500	900	750
4	500	900	600	1000	925
5	566	966	700	1100	1100
6	633	1033	800	1200	1275
7	700	1100	900	1300	1450

■ RECOMMANDÉ / RECOMMENDED

TABLEAU D'AJUSTEMENT DES DÉBITS D'AIR  
AIRFLOW SETTINGS TABLE

MODÈLE / MODEL 1521	CONT. VENT.		W VENT.		Y VENT.
	LOW	HIGH	W1	W2	
1	300	700	350	850	600
2	366	766	530	1030	742
3	433	833	710	1210	884
4	500	900	900	1400	1025
5	566	966	1080	1450	1167
6	633	1033	1260	1450	1309
7	700	1100	1450	1450	1450

■ RECOMMANDÉ / RECOMMENDED

TABLEAU D'AJUSTEMENT DES DÉBITS D'AIR  
AIRFLOW SETTINGS TABLE

MODÈLE / MODEL 1821	CONT. VENT.		W VENT.		Y VENT.
	LOW	HIGH	W1	W2	
1	300	700	350	850	600
2	366	766	530	1030	742
3	433	833	710	1210	884
4	500	900	900	1400	1025
5	566	966	1080	1450	1167
6	633	1033	1260	1450	1309
7	700	1100	1450	1450	1450

■ RECOMMANDÉ / RECOMMENDED

TABLEAU D'AJUSTEMENT DES DÉBITS D'AIR  
AIRFLOW SETTINGS TABLE

MODÈLE / MODEL 2021	CONT. VENT.		W VENT.		Y VENT.
	LOW	HIGH	W1	W2	
1	300	700	450	1150	800
2	366	766	615	1315	908
3	433	833	785	1450	1016
4	500	900	950	1450	1125
5	566	966	1115	1450	1234
6	633	1033	1285	1450	1342
7	700	1100	1450	1450	1450

■ RECOMMANDÉ / RECOMMENDED

TABLEAU D'AJUSTEMENT DES DÉBITS D'AIR  
AIRFLOW SETTINGS TABLE

MODÈLE / MODEL 2321	CONT. VENT.		W VENT.		Y VENT.
	LOW	HIGH	W1	W2	
1	300	700	450	1150	800
2	366	766	615	1315	908
3	433	833	785	1450	1016
4	500	900	950	1450	1125
5	566	966	1115	1450	1234
6	633	1033	1285	1450	1342
7	700	1100	1450	1450	1450

■ RECOMMANDÉ / RECOMMENDED

TABLEAU D'AJUSTEMENT DES DÉBITS D'AIR  
AIRFLOW SETTINGS TABLE

MODÈLE / MODEL 2021-1	CONT. VENT.		W VENT.		Y VENT.
	LOW	HIGH	W1	W2	
1	400	1200	450	1150	800
2	533	1333	710	1410	1033
3	666	1466	965	1665	1266
4	800	1600	1225	1925	1500
5	933	1733	1485	2000	1733
6	1066	1866	1740	2000	1966
7	1200	2000	2000	2000	2200

■ RECOMMANDÉ / RECOMMENDED

**TABLEAU D'AJUSTEMENT DES DÉBITS D'AIR  
AIRFLOW SETTINGS TABLE**

MODÈLE / MODEL 2321-1	CONT. VENT.		W VENT.		Y VENT.
	LOW	HIGH	W1	W2	
1	400	1200	450	1150	800
2	533	1333	710	1410	1033
3	666	1466	965	1665	1266
4	800	1600	1225	1925	1500
5	933	1733	1485	2000	1733
6	1066	1866	1740	2000	1966
7	1200	2000	2000	2000	2200

■ RECOMMANDÉ / RECOMMENDED

**TABLEAU D'AJUSTEMENT DES DÉBITS D'AIR  
AIRFLOW SETTINGS TABLE**

MODÈLE / MODEL 2721	CONT. VENT.		W VENT.		Y VENT.
	LOW	HIGH	W1	W2	
1	400	1200	750	1500	800
2	533	1333	992	1742	1033
3	666	1466	1233	1983	1266
4	800	1600	1475	2200	1500
5	933	1733	1717	2200	1733
6	1066	1866	1740	2200	1966
7	1200	2000	2200	2200	2200

■ RECOMMANDÉ / RECOMMENDED

**TABLEAU D'AJUSTEMENT DES DÉBITS D'AIR  
AIRFLOW SETTINGS TABLE**

MODÈLE / MODEL 3021	CONT. VENT.		W VENT.		Y VENT.
	LOW	HIGH	W1	W2	
1	400	1200	750	1500	800
2	533	1333	992	1742	1033
3	666	1466	1233	1983	1266
4	800	1600	1475	2200	1500
5	933	1733	1717	2200	1733
6	1066	1866	1740	2200	1966
7	1200	2000	2200	2200	2200

■ RECOMMANDÉ / RECOMMENDED

## MAINTENANCE



**N.B. In order for the warranty to be valid, the unit must be cleaned regularly.**

Cut off power supply at circuit breaker/fuse before cleaning the unit. Use a soft rag for dusting. When cleaning, use only a damp rag and non-abrasive dish soap. Do not use abrasive or chemical cleaners because they may damage the finishing. If the unit is used in a very dusty location, use a vacuum brush to remove dust and other foreign objects from the grilles. Note that cigarette smoke could yellow the discharge grille and that the best way to prevent it is to clean the unit on a regular basis.

**Do not use cleaning products identified with these symbols:**



**N.B. Note that there is electrical current linked to the unit even if the thermostat is set off. This means that there is a risk of electric shock as long as the unit is energized.**

### PREVENTIVE MAINTENANCE

Do not try to repair your furnace yourself. Call a qualified technician. However, before calling a technician, check the following points.

1. Make sure fuses or circuit breakers are activated.
2. Adjust the temperature set point of the thermostat above the ambient temperature. If heating does not start, cut off the power supply and call a technician.

**N.B. When calling a technician for maintenance or to order a replacement part, specify the model of your furnace as well as its serial number.**

### AIR FILTER

Excessive dust or dirt accumulation can block the airflow, forcing the unit to work harder to maintain the desired temperature. Therefore, it uses more energy and increases heating costs.

Since the air filter supplied is disposable, you should replace it two to four times a year, according to the model used and the installation area. Dirtier areas can require more than four filter changes.

To replace a dirty filter, open the access door to the filter, remove the old filter and insert the new one inside the rack. Make sure the new filter has the same technical specifications and size as the previous one.

**N.B. Never operate the unit without a filter in place.**

Every time a filter is changed, you should check the following points.

- Excessive accumulation of dirt or dust on furnace components.
- Damaged components or surfaces.
- Presence of water inside or outside the furnace.

If you encounter any of these problems, do not operate the furnace. Call a qualified technician.

### BLOWER

The blower motor is sealed and permanently lubricated, so it is not necessary to lubricate it.

Even if you change the filter frequently, the blower's blades and motors will become dust laden after a few months. The entire blower assembly should be inspected annually. If needed, vacuum out the dust. If you cannot clean the blower without removing it from the furnace, this service must be performed by a qualified technician.

## **CONTROL CARD AUTODIAGNOSTIC**

The control card of the furnace is equipped with a pilot LED that allow easy and quick diagnostic of its essential functions. The yellow LED is located at the top right side of the control panel (item #10 of the control panel picture).

The pilot LED will start to blink continuously when an electrical problem occurs.

### **TROUBLESHOOTING**

<b>PROBLEM</b>	<b>DEFECTIVE PART OR PART TO CHECK</b>
The unit does not work	<ul style="list-style-type: none"> <li>- Defective thermostat, wrong thermostat setting or positioning</li> <li>- Open circuit breaker or fuse</li> <li>- Faulty connections</li> <li>- Faulty motor or condensator</li> <li>- Faulty blower control switch</li> <li>- Faulty transformator</li> <li>- See above: CONTROL CARD AUTODIAGNOSTIC</li> </ul>
The unit runs continuously	<ul style="list-style-type: none"> <li>- Defective thermostat, wrong thermostat setting or positioning</li> <li>- Heat losses greater than the unit capacity</li> <li>- Faulty relay</li> <li>- Thermostat wire incorrectly connected to the furnace</li> <li>- See above: CONTROL CARD AUTODIAGNOSTIC</li> </ul>
The unit cycles under control of the thermal protection (overheat indicator)	<ul style="list-style-type: none"> <li>- Blocked air vents</li> <li>- Defective motor</li> </ul>
Overheating	<ul style="list-style-type: none"> <li>- Defective thermostat, wrong thermostat setting or positioning</li> <li>- Defective motor</li> </ul>
The breaker trips when the heater is turned on	<ul style="list-style-type: none"> <li>- Faulty connections</li> <li>- Voltage higher than that indicated on the nameplate</li> </ul>
Elements are on, but the motor does not work	<ul style="list-style-type: none"> <li>- Defective motor or condensator</li> <li>- Faulty relay</li> </ul>
The desired room temperature cannot be reached	<ul style="list-style-type: none"> <li>- One or more defective elements</li> <li>- Defective thermostat or wrong thermostat setting</li> <li>- Voltage lower than that indicated on the nameplate</li> <li>- Heat losses greater than the unit capacity</li> <li>- Faulty relay</li> </ul>

**N.B. If you do not solve the problem after checking these points, cut off the power supply at the main electrical panel and contact our customer service (see the "Limited warranty" section to obtain the phone numbers).**

# REPLACEMENT COMPONENT LIST

REF. #	PART #	DESCRIPTION
1	ELF-SFE0221-1	ELEMENT ASSEMBLY SFE 2.5KW/240V/1PH 11" LONG
1	ELF-SFE0221-2	ELEMENT ASSEMBLY SFE 2.5KW/240V/1PH 14" LONG
1	ELF-SFE0521-1	ELEMENT ASSEMBLY SFE 5KW/240V/1PH 11" LONG
1	ELF-SFE0521-2	ELEMENT ASSEMBLY SFE 5KW/240V/1PH 14" LONG
2	BLO-004	SQUIRREL CAGE & BLOWER 10-8
2	BLO-005	SQUIRREL CAGE & BLOWER 12-11
3	MO-034	ECM MOTOR 1/2HP
3	MO-035	ECM MOTOR 1 HP
4	SUP-002	MOTOR SUPPORT FOR BLO-005
4	SUP-004	MOTOR SUPPORT FOR BLO-004
5	PROT-045	THERMAL PROTECTION L140-40F
7	REL-021	RELAY, DPDT, 30 A, 24 VDC
8	CIR-024	ELECTRONIC BOARD FOR SFECM FURNACE
9	TRF200040D	TRANSFORMER, 240-208V/24VAC/40 VA, CL.2
10	BREA-003	CIRCUIT BREAKER, 120/240 VAC, 50 A, 2 P

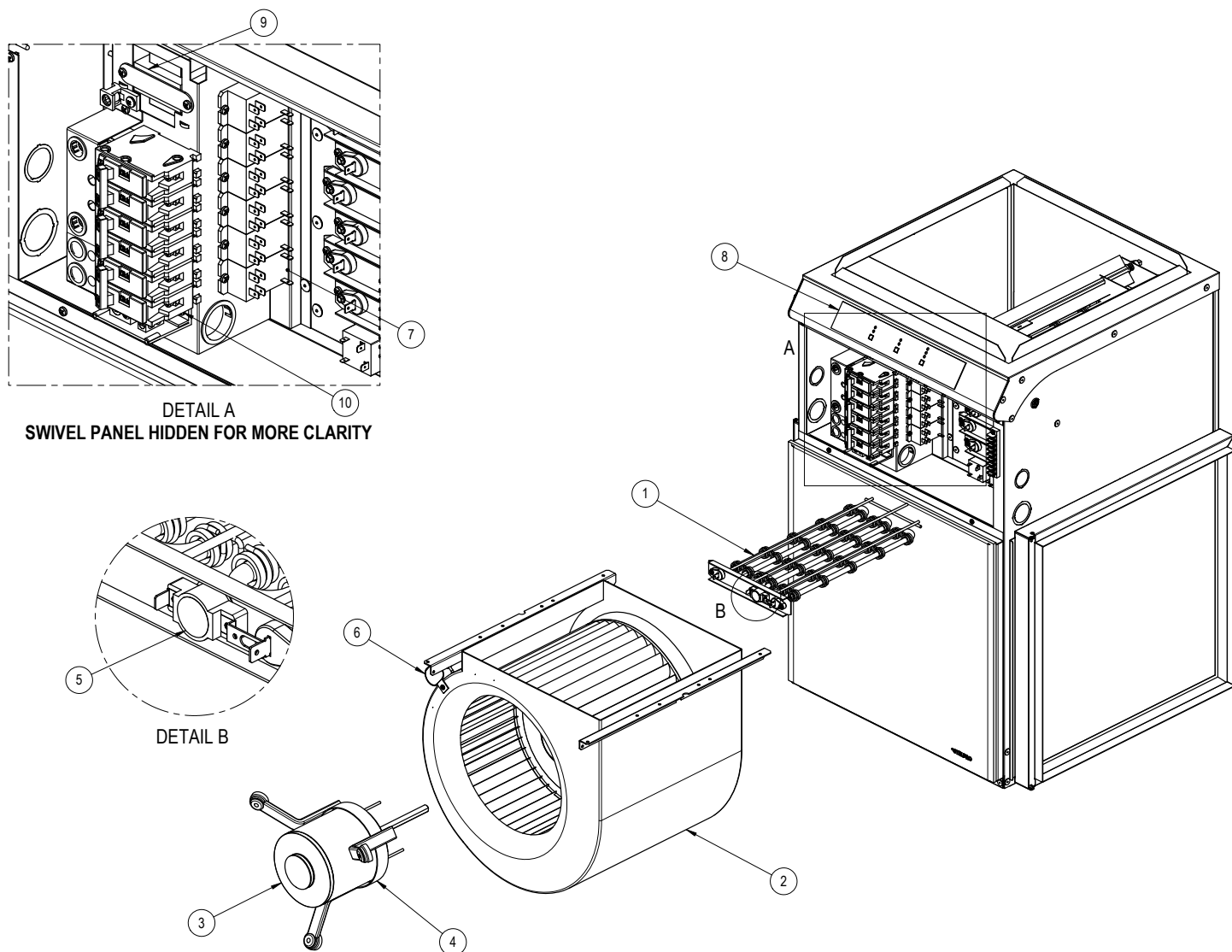

# LIMITED WARRANTY

This limited warranty is offered by Stelpro Design inc. ("Stelpro") and applies to the following products made by Stelpro: SFECM10, SFECM15, SFECM18, SFECM20, SFECM23, SFECM27, SFECM30 models. **Please read this limited warranty carefully.** Subject to the terms of this warranty, Stelpro warrants its products and their components against defects in workmanship and/or materials for the following periods from the date of purchase: **5 years**. This warranty applies only to the original purchaser; it is non-transferable and cannot be extended.

## CLAIM PROCEDURE

If at any time during the warranty period the unit becomes defective, you must cut off the power supply at the main electrical panel and contact 1) your installer or distributor, 2) your service center or 3) Stelpro's customer service department. In all cases, you must have a **copy of the invoice** and provide the **information written on the product nameplate**. Stelpro reserves the right to examine or to ask one of its representatives to examine the product itself or any part of it before honoring the warranty. Stelpro reserves the right to replace the entire unit, refund its purchase price or repair a defective part. Please note that repairs made within the warranty period must be authorized in advance in writing by Stelpro and carried out by persons authorized by Stelpro.

Before returning a product to Stelpro, you must have a Stelpro authorization number (RMA). To obtain it, call the customer service department at: **1-800-363-3414** (electricians and distributors - French), **1-800-343-1022** (electricians and distributors - English), or **1-866-766-6020** (consumers). The authorization number must be clearly written on the parcel or it will be refused.

## CONDITIONS, EXCLUSIONS AND DISCLAIMER OF LIABILITY

This warranty is exclusive and in lieu of all other representations and warranties (except of title), expressed or implied, and Stelpro expressly disclaims and excludes any implied warranty of merchantability or implied warranty of fitness for a particular purpose.

Stelpro's liability with respect to products is limited as provided above. Stelpro shall not be subject to any other obligations or liabilities whatsoever, whether based on contract, tort or other theories of law, with respect to goods or services furnished by it, or any undertakings, acts or omissions relating thereto. Without limiting the generality of the foregoing, Stelpro expressly disclaims any liability for property or personal injury damages, penalties, special or punitive damages, damages for lost profits, loss of use of equipment, cost of capital, cost of substitute products, facilities or services, shutdowns, slowdowns, or for other types of economic loss or for claims of a dealer's customers or any third party for such damages. Stelpro specifically disclaims all consequential, incidental and contingent damages whatsoever.

This warranty does not cover any damages or failures resulting from: 1) a faulty installation or improper storage; 2) an abusive or abnormal use, lack of maintenance, improper maintenance (other than that prescribed by Stelpro) or a use other than that for which the unit was designed; 3) a natural disaster or an event out of Stelpro's control, including, but not limited to, hurricanes, tornadoes, earthquakes, terrorist attacks, wars, overvoltage, flooding, water damages, etc. This warranty does not cover any accidental or intentional losses or damages, nor does it cover damages caused by negligence of the user or owner of the product. Moreover, it does not cover the cost of disconnection, transport, and installation.

The warranty is limited to the repair or the replacement of the unit or the refund of its purchase price, **at the discretion of Stelpro**. Any parts replaced or repaired within the warranty period with the written authorization of Stelpro will be warranted for the remainder of the original warranty period. This warranty will be considered null and void and Stelpro will have the right to refuse any claims if **products have been altered** without the written authorization of Stelpro and if the nameplate numbers have been removed or modified. This warranty does not cover scratches, dents, corrosion or discoloration caused by excessive heat, chemical cleaning products and abrasive agents. It does not cover any damage that occurred during the shipping.

Some states and provinces do not allow the exclusion or limitation of incidental or consequential damages and some of them do not allow limitations on how long an implied warranty lasts, so these exclusions or limitations may not apply to you. This warranty gives you specific legal rights and you may have other rights which vary from state to state or from province to province.