

A long row of grey Siemens tiastar Motor Control Centers (MCC) in an industrial setting. The units are arranged in a perspective view, receding into the distance. Each unit has a control panel with a digital display and various switches. The Siemens logo is visible on the top left of the first unit. The background is a plain, light-colored wall.

SIEMENS

tiastar™ Motor Control Center Catalog and Application Guide

Game Changing Innovation

usa.siemens.com/mcc

Answers for industry.

Table of Contents

Introduction

tiastar MCC	4
Product Features and Benefits	6
tiastar Arc Resistant MCC	8
Key Innovations of Arc Resistant Design	10
tiastar Smart MCC	12

General Information

Codes and Standards	14
Estimated MCC Shipping Weight	15
NEMA Wire Classes and Types	16
MCC Heat Dissipation	18
Altitude Ratings	20

Structure and Bussing

NEMA Enclosure Types	21
Paint and MCC Finish	22
Structure Design and Options	23
Bus Selection and Options	26
Wireways	29

Mains, Feeders, and Incoming Devices

Incoming Line Termination & Cable Space	30
Main Lug Only (MLO)	32
Main Circuit Breaker (MCB)	34
Main Disconnect Switch (MDS)	36
Feeders	38
Bus Splice & Bus Duct	42
TPS3 Surge Protective Devices (SPD)	44

Units

Plug-in Unit Features	46
Combination Starters	48
Compact High Density (HD) Combination Starters	56
Reduced Voltage Soft-Starter (RVSS) Units	57

Variable Frequency Drive (VFD) Units	
Micromaster	61
SINAMICS G120C	67
SINAMICS G120	70
Unit Options Overload	76
SIMOCODE	77
Terminal Blocks	79
Wiring Specifications	81
Pilot Devices	82
Control Transformer Sizes	84
Handle Auxiliary Switch	84
Nameplate	85
Programmable Logic Controller (PLCs) Units	86
Metering Units	87
Panelboard and Transformer Units	89
High Resistance Ground Unit Option	90

Standard MCC Catalog Items

Feeder Circuit Breaker (FCB)	
Vertical Catalog Sections	92
Blank, Panel, MLO and MCB	
Vertical Catalog Sections	95
Feeder Circuit Breaker (FCB)	
Catalog Units	98
Full Voltage Non-Reversing (FVNR)	
Catalog Units	101
Common Modification Kits	104
Other Modification Kits	105

Appendix

Drawings and Dimensions	106
Motor Circuit Protector (MCP) Selection	118
Breaker Trip Settings	119
Breaker Selection	120
Fuse Selection/UL Standard	
Fuse Classifications	121
Heater Tables	124
Typical Schematic	128
Aftermarket	136
Typical Specifications	
General MCC or Arc Resistant MCC	137
Smart MCC	142
MCC Training	149

For instruction manuals and instructional videos please see the Siemens Motor Control Center website usa.siemens.com/mcc





tiastar MCC

Motor Control Centers (MCC) have come a long way since they were introduced in 1937 as a way to save floor space by placing several starters in a single cabinet. Ideally, the best of the best must also save installation time and money.

Siemens has an installed base of Motor Control Centers dating back to 1964. Our Siemens tiastar MCCs are designed as self-contained modular units which meets UL and NEMA standards. They come with rear-mounted, self-aligning copper stabs that firmly grasp onto the bus. Brackets guide the placement of units, further assuring positive engagement with the bus. From 22mm to 30mm pilot devices, from direct starters to world-class drives, the Siemens tiastar MCC has many features and options to meet your specific needs.

- UL 845 Labeling as applicable
- CSA C22.2 No. 254-05 Labeling as applicable when specified
- Heavy-Duty Construction with up to 100kA Bus Bracing
- 600V 50/60 Hz
- NEMA Wiring
- Plug-In Units (up to Size 5 Starters)
- Door/Unit Mounted Pilot Device Panel
- High Density Compact Units available to reduce footprint

Technical Specifications Summary – tiastar MCC

Bus and Electrical Ratings	
Horizontal Bus Ratings	600A, 800A, 1200A, 1600A, 2000A, 2500A ¹
Horizontal Bus Material	Copper with tin or silver plating, or Aluminum ² with tin plating
Vertical Bus Ratings	300A, 600A, 800A
Vertical Bus Options	Isolated (standard) Insulated and isolated (optional) Auto Shutters (optional)
Bus Bracing	42K AIC, 65K AIC, 100K AIC
Max MCC Voltage Rating	600 V

For further bus information please see the "Bus Selection and Options" section

Enclosure	
Enclosure Type	NEMA 1 (standard), NEMA 1A, NEMA 2, NEMA 12, NEMA 3R (non walk-in)
Back-to-Back Option	Available



Dimensions	
Section Depth	15", 20" , 21" (back-to-back), 31" (double deep), 41" (double deep)
Section Width	20", 24", 30", 40", 50", 60"



¹ NEMA 1 only and requires forced ventilation

² for 600-1200A, 65KA, 65°C

Product Features & Benefits

Siemens tiastar Motor Control Centers (MCC) are composed of a number of vertical sections bolted together which allows for future addition of MCC vertical sections in case the customer requires expansion.

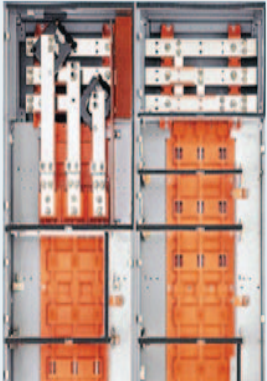
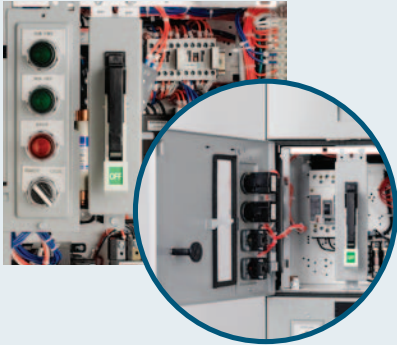
Benefits		Feature
<p><i>Easy accessibility for faster maintenance</i></p>		<p>Entire horizontal bus assembly is in top 12" of the vertical section</p>
<p><i>Easy visual inspection of horizontal bus</i></p>		<p>Clear Lexan® horizontal wireway barrier</p>
<p><i>Ease of installation and movement of plug-in units</i></p>		<p>Plug-in units with integrated racking handles</p>

Benefits		Feature
<p><i>Prevents arcing faults from propagating</i></p>		<p>Isolated and insulated vertical bus assembly (Optional)</p>
<p><i>Improved service access to save time</i></p>		<p>Dual location pilot device panel</p>
<p><i>Clearly indicates equipment status (ON, TRIP, OFF)</i></p>		<p>Industry's best unit operating handle</p>

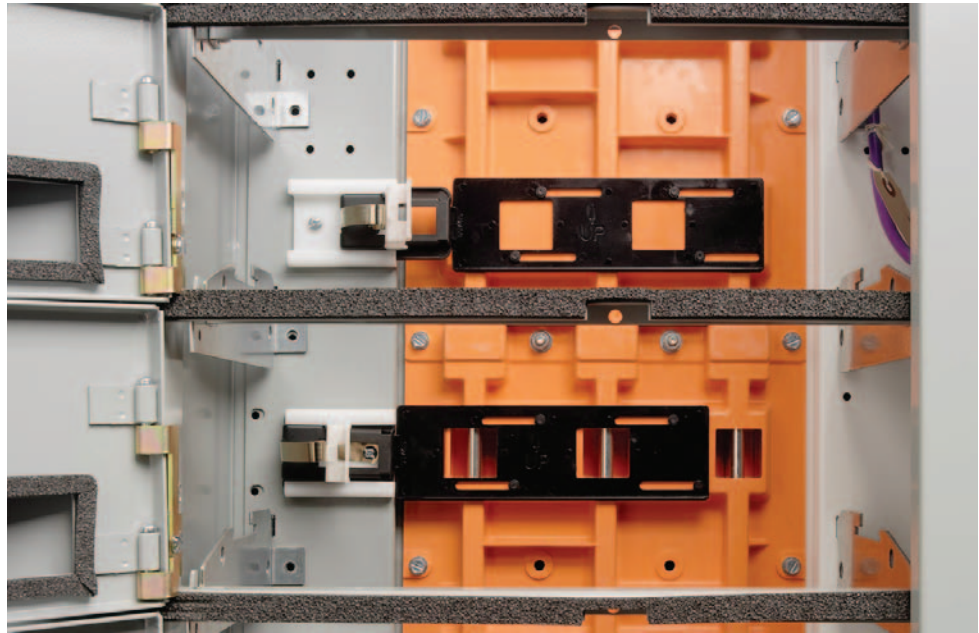

tiastar Arc Resistant MCC

The Type 2A Arc Resistant low voltage motor control center is a new product offering that was tested in accordance to IEEE C37.20.7, which contains and channels internal arcing fault incident energy. It provides an additional degree of protection to the personnel performing normal operating duties in close proximity to the equipment while the equipment is operating under normal conditions. Type 2A accessibility means the MCC protects the operator in front, back and sides of the equipment.

The Arc Resistant MCC is a state-of-art overarching technology. This means one can get an Arc Resistant MCC that can have various Smart components with communications, and/or High Density compact units.

Technical Specifications Summary – tiastar Arc Resistant MCC

Bus and Electrical Ratings	
Maximum Horizontal Bus	1600 A
Maximum Vertical Bus	800 A
Maximum Short Circuit Withstand Rating	65KA
Arc Flash Duration	50ms (3 cycles)
Maximum Voltage Rating	600VAC
Horizontal Bus Details	Copper Only
Incoming	MLO, MCB/MDS 1600 A max, splice to existing ¹

Enclosure	
Enclosure Type	NEMA 1 and 1A
High Density Units Option	Available
VFD, RVSS Units	Available
Double Deep Option	Available

Dimensions	
Modified Pull Box Height	12" Minimum (standard), 18" and 24" (optional)
Section Depth	20"
Section Width	20" or 30"
Total MCC Height	102" Minimum ²
Room Requirements	112" Minimum Ceiling Height (Total MCC Height + 10") 38" Minimum Aisle

¹ The Arc Resistant MCC should not be spliced to a Non-Arc Resistant MCC.

² If the mounting channels are surface mounted then the minimum height is 103" (90" MCC height + 1" mounting channels + 12" modified pull box). Also, note that the total MCC height will increase if standard modified pull box is not selected.

Key Innovations and Benefits of Arc Resistant Design

AUTOMATIC SHUTTERS

The barrier automatically opens and closes to allow insertion or removal of units. It isolates the vertical bus to prevent inadvertent contact lowering the risk to personnel.

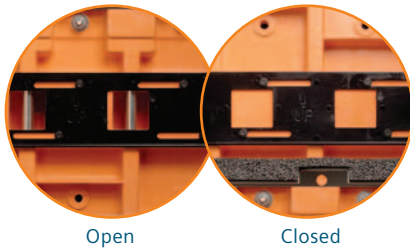

Open

Closed

INSULATED BUS BAR

Isolates energized components, prevents accidental contact, and keeps arcing faults from propagating.

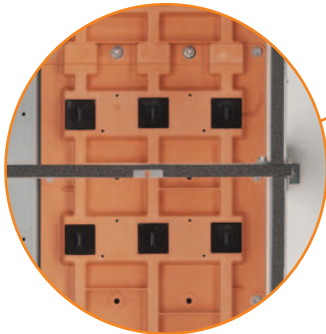

REINFORCED DOORS

Reinforced cabinet ensure the equipment can withstand and contain pressure from internal arcing faults.



BOLTED WIREWAY

The wireway is bolted to ensure integrity of the MCC wireway is sustained during an arc flash incident.

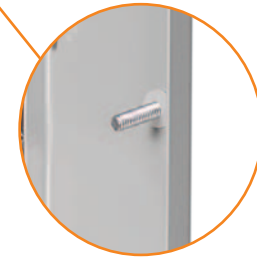

INTERNAL VENTING SYSTEM

The vertical wireway is perforated with holes that channel the gasses to the back and out the top of the MCC.

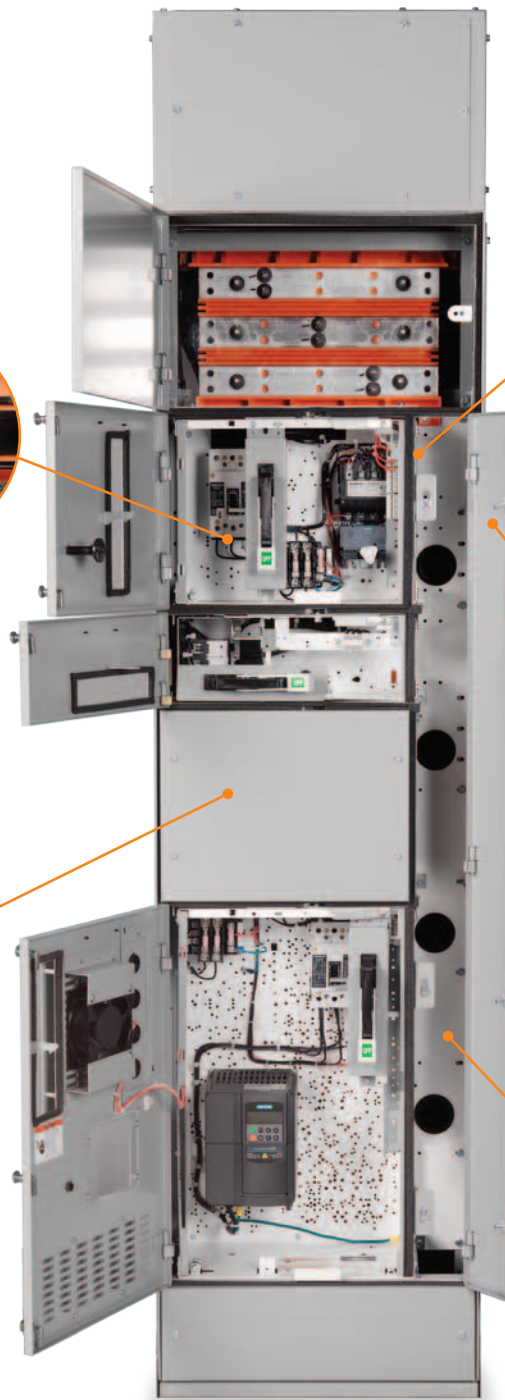

Figure 1. Arc Resistant MCC

DEFLECTORS

The protection plate will allow MCCs to have vented doors, but will reduce the direct launching of arc flash by-products.

**MODIFIED PULL-BOX WITH PRESSURE FLAP**

The arc flash by-products will be prevented from escaping due to the wire mesh, while the pressure flap will allow pressure release.



Figure 2. Closed Door View - Arc Resistant MCC

Dynamic Arc Flash Sentry (DAS)

To complement the Arc Resistant MCC, the Dynamic Arc Flash Sentry (DAS) option is available. Dynamic Arc Flash Sentry (DAS) is a patented feature available in both Siemens MCCs and type WL Low Voltage Switchgear. The unique dual trip setting technology reduces the energy available in an arc flash event.

For more information, please see the Dynamic Arc Flash Reduction System and its Application in Motor Control Centers white paper at www.usa.siemens.com/mcc





tiastar Smart MCC

A Smart MCC is a networked NEMA compliant MCC that can communicate. It incorporates intelligent devices at the unit level to control and monitor motor operation, energy consumption, and power quality. It rapidly communicates with a PLC or process control system via a data network.

Smart MCC Components

Smart MCC is internally interconnected using PROFIBUS DP which incorporates intelligent devices such as SIMOCODE pro C and V motor management systems, SIRIUS 3RW44 soft starters, SIMATIC PLCs, Siemens VFDs, and other smart components.

Major Benefits

- Reduces Wiring Connections
- Reduces Cost
- Improves Operational Diagnostics
- Simplifies Installation and Troubleshooting

tiastar Smart MCC Network Architecture

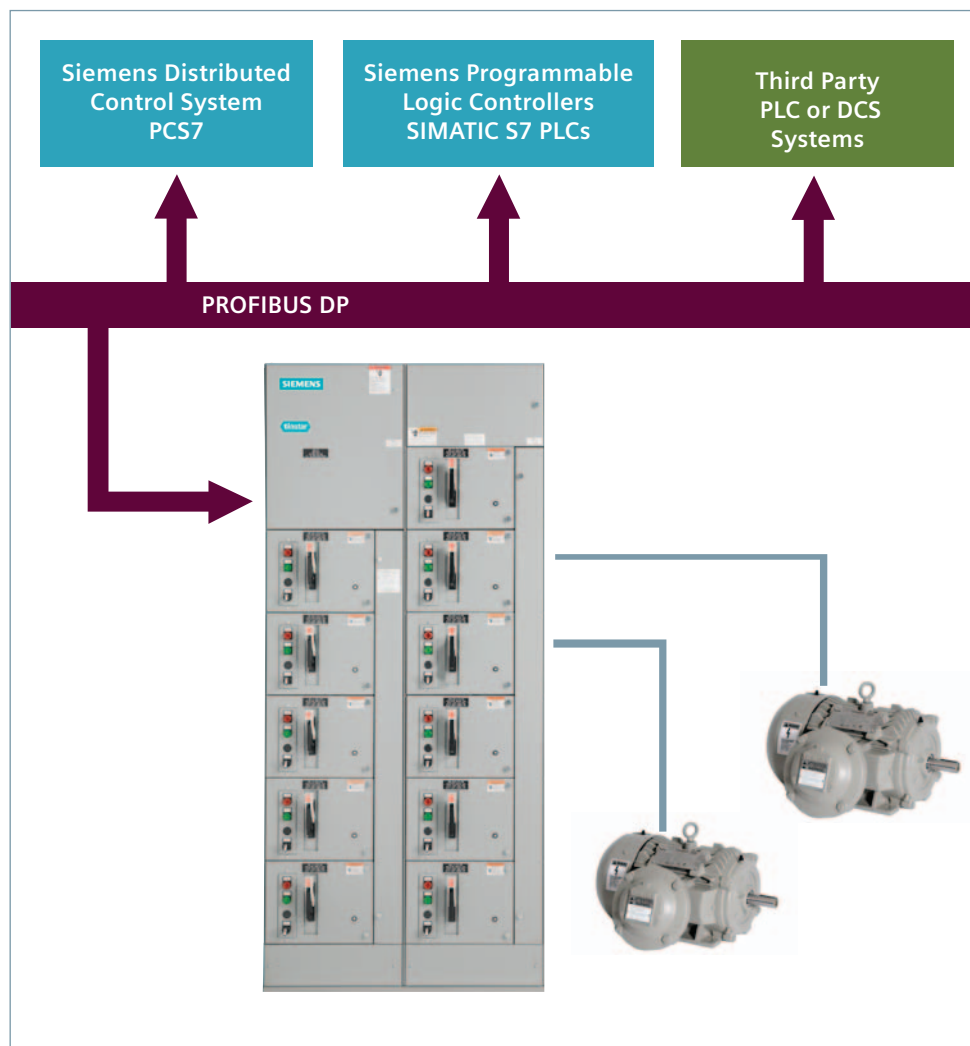

Figure 3. Example of a Smart MCC Network with PROFIBUS

Options

A Smart MCC has the option to externally talk to other networks such as DeviceNet, Modbus RTU, Modbus TCP/IP, EtherNet/IP, and PROFINET.

VFD, RVSS Units	Available
High Density 6" Units Option	Not Available
Back-to-Back Option	Available
Double Deep Option	Available

Codes and Standards

 	<p>Siemens tiastar MCCs are manufactured to American National Standards Institute (ANSI) / Underwriters Laboratories (UL) 845 standard and contain the “UL Listed” label.</p>
	<p>Siemens tiastar MCCs complies with National Electrical Manufacturers Association (NEMA) ICS 18-2001.</p>
	<p>Siemens tiastar MCCs also complies with Canadian Standards Association (CSA) C22.2 No. 254-05 standards.</p>
	<p>Siemens tiastar MCCs are American Bureau of Shipping (ABS) Type Approval Certificated.¹</p>
<p>Seismic Certification</p>	<p>Siemens tiastar Motor Control Centers are certified to CBC-2013 Section 170A 12 and IBC 2012 Section 1705.12.</p>
<p>OSHPD</p>	<p>Siemens tiastar Motor Control Centers can also have Office of Statewide Health Planning and Development Facilities (OSHPD) Special Seismic Certification Preapproval (OSP).</p>

1. Some restrictions may apply. Please contact factory for further details.

Estimated MCC Shipping Weight

Dimensions in Inches (mm)		Type	Weight per Section in lbs (Kg) for NEMA 1, 2, or 12	Weight per Section in lbs (Kg) for NEMA 3R
Width	Depth			
20" (508)	15" (381)	Front Only	550 (250)	650 (295)
20" (508)	20" (508)	Front Only	650 (295)	700 (318)
30" (762)	15" (381)	Front Only	700 (318)	800 (363)
30" (762)	20" (508)	Front Only	850 (386)	900 (409)
20" (508)	21" (533)	Back-to-Back	670 (304)	N/A
30" (762)	21" (533)	Back-to-Back	880 (400)	N/A

Note: MCC shipping split maximum is 80 inches (for example, four 20-inch wide vertical sections).

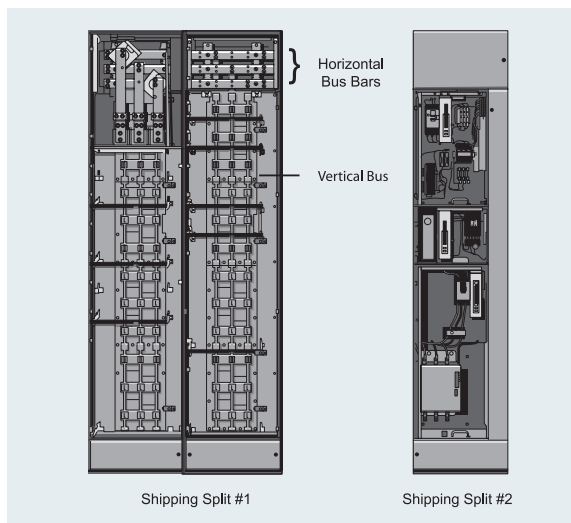

When a motor control center is made up of more than one vertical section, the sections are assembled together with a common top-frame and bottom-frame assembly. For shipping, this assembly can consist of a maximum of four 20-inch wide vertical sections (80" maximum). Several assemblies can be bolted and bussed together at the installation site to form a complete lineup.

Figure 4. Example of shipping split

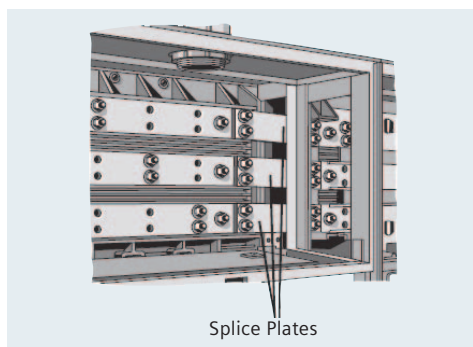

When there are more than four sections or the customer specifies a split between two vertical sections, a splice kit, must be installed to join the horizontal bus bars.

Figure 5. Splice plates

NEMA Wire Classes and Types

Siemens MCCs are available as either Class I or Class II assemblies utilizing either Type A, Type B, or Type C wiring as defined in NEMA ICS18-2001. Below are the NEMA class and type definitions:

NEMA Classes

Class I — Independent Units

Class I motor control centers shall consist of mechanical groupings of combination motor control units, feeder tap units, other units, and electrical devices arranged in a convenient assembly. The manufacturer shall furnish drawings that include:

a. Overall dimensions of the motor control center, identification of units and their location in the motor control center, locations of incoming line terminals, mounting dimensions, available conduit entrance areas, and the location of the master terminal board if required (Type C wiring only).

b. Manufacturer's standard diagrams for individual units and master terminal boards (Type C wiring only) consist of one or more drawing(s) that:

- Identify electrical devices
- Indicate electrical connections
- Indicate terminal numbering designations

Note: When a combination schematic and / or wiring diagram for a unit is supplied showing optional devices, the manufacturer shall provide information to indicate which devices are actually furnished.

Class II — Interconnected Units

Class II motor control centers shall be the same as Class I motor control centers with the addition of manufacturer furnished electrical interlocking and wiring between units as specified in overall control system diagrams supplied by the purchaser. In addition to the drawings furnished for Class I motor control centers, the manufacturer shall furnish drawings that indicate factory interconnections within the motor control center.

Class I-S and II-S — Motor Control Centers with Custom Drawing Requirements

Class I-S and II-S motor control centers shall be the same as Class I and II except custom drawings shall be provided in lieu of standard drawings as specified by the user.

Examples of custom drawings are

- Special identifications for electrical devices
- Special terminal numbering designations
- Special sizes of drawings

The drawings supplied by the manufacturer shall convey the same information as drawings provided with Class I and II motor control centers, additionally modified as specified by the user.

NEMA Types

Type A

User field wiring shall connect directly to device terminals internal to the unit and shall be provided only on Class I motor control centers.

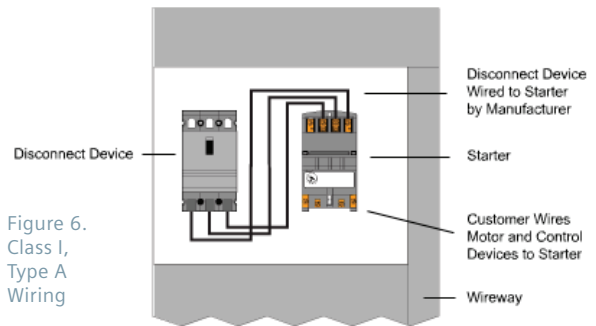

Figure 6.
Class I,
Type A
Wiring

Type B

Type B user field load wiring for combination motor control units size 3 or smaller shall be designated as B-d or B-t, according to the following:

B-d connects directly to the unit terminals, which are located immediately adjacent and readily accessible to the vertical wireway.

B-t connects directly to a load terminal block in, or adjacent to, the unit.

Type B user field load wiring for combination motor control units larger than size 3, and for feeder tap units, shall connect directly to unit device terminals.

Type B user field control wiring shall connect directly to unit terminal block(s) located in, or adjacent to, each combination motor control unit.

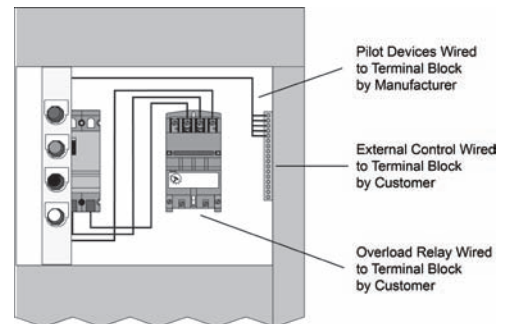

Figure 7.
Class I,
Type B-d
Wiring

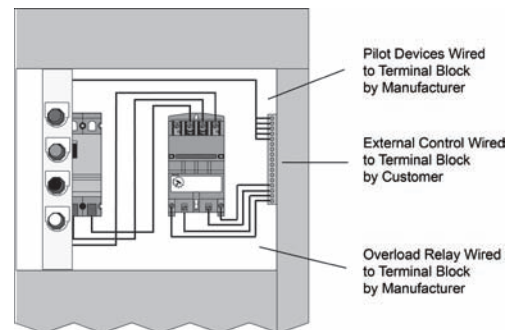

Figure 8.
Class I,
Type B-t
Wiring

Type C

User field control wiring shall connect directly to master terminal blocks mounted at the top or bottom of those vertical sections that contain combination motor control units or control assemblies which shall be factory wired to their master terminal blocks. User field load wiring for combination motor control units, size 3 or smaller, shall connect directly to master terminal blocks mounted at the top or bottom of vertical sections. Motor control unit load wiring shall be factory wired to the master terminal blocks. User field load wiring for combination motor control units larger than size 3, and for feeder tap units, shall connect directly to unit device terminals.

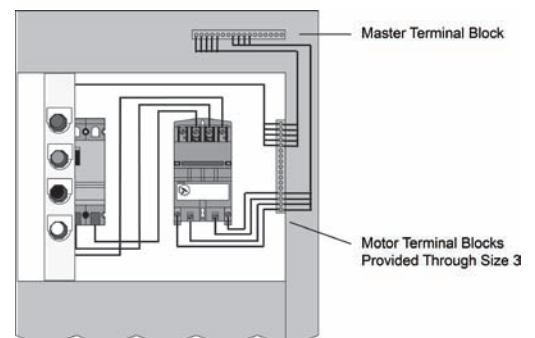

Figure 9.
Class I,
Type C
Wiring

MCC Heat Dissipation

The purpose of this section is to allow the reader to approximate the heat output of an MCC. This information is based on power loss data collected for the major heat producing components.

The data presented here is based off the maximum rated current for each component. If the true loading current is known, then the estimate can be improved by multiplying the given power loss by the

square of the true current divided by the square of the rated current:

$$P_{actual} = P_{max} \frac{i^2_{actual}}{i^2_{max}}$$

The power losses can be multiplied by 3.412 to convert them from Watts to BTU/hr.

1. Combination Motor Starters

		Maximum Power Loss (3-Pole) [W]				
Size	i_{max} [A]	Contactors	Breaker	Overload	CPT	Total
0	18	6	12	6	17	41
1	27	18	15	6	17	58
2	50	28	21	6	17	72
3	95	52	24	6	29	111
4	185	55	60	6	29	150
5	300	84	93	6	17	200
6	500	190	174	6	17	387

2. Circuit Breakers

i_{max} [A]	Watts Loss (3-pole)
3	5
15	8
30	11
60	20
100	36
200	60
400	130
800	192
1200	259
1600	461
2000	720

3. Lighting Transformers

KVA	Watts Loss
6	300
9	400
10	542
15	658
20	761
25	761
30	995
37.5	1135
45	1276

4. Reduced Voltage Soft Starters

	Family	i_{max}	Power Loss (W)
3RW30	1X	17	4
	2X	34	19
	3X	63	15
	4X	98	21
3RW40	2X	29	19
	3X	63	15
	4X	98	21
	5X	145	75
3RW44	7X	385	165
	2X	82	55
	3X	145	95
	4X	385	232
	5X	850	270
	6X	1078	630

MCC Heat Dissipation

5. Panel Boards

Size	$i_{max}[A]$	Maximum Power Loss (3-Pole) [W]				
		Bus	Main Breaker	Branch Circuits		
				18	36	42
P1	400	380	129	87	77	80
P2	600	420	216	99	97	109
P3	800	470	192	116	96	113

6. Variable Frequency Drives

The power loss for a variable frequency drive is approximately 3.5% of the overall power:

$$Power\ Loss = (HP\ of\ Motor) \cdot \frac{0.746W}{HP} \cdot 3.5\%$$

$i_{max}[A]$	Maximum Power Loss (3-Pole) [W]		
	Horizontal (20" Section)		Vertical (72" Section)
	Aluminum	Copper	Copper
300			57
600	90	54	115
800	107	64	240
1200	120	72	
1600		85	
2000		66	
2500		104	

The data presented here is subject to change, without notice, owing to periodic updates and corrections. Please be advised that several assumptions had to be made in order to generate this and, accordingly, no representation or warranty is given with regard to its accuracy or completeness of the information as the same has been included for general purposes only and that, it should not be relied upon for any specific purpose. Siemens industry, inc. Or its affiliates, officers, employees or agents are neither responsible nor liable for inaccuracies, errors or omissions, or for any loss, damage or expense, including, without limitation, any loss of profit, indirect, special, incidental or consequential loss / damages, arising out of this data.

Altitude Ratings

Siemens tiastar Motor Control Centers are designed and built to operate up to 2000 meters above sea level (6,600 ft) without any modifications.

Motor control centers are often installed in applications exceeding 1000 meters (3300 ft) above sea level. Due to the lower air density and heat transfer capacity at elevated altitudes, the physical properties such as dielectric strength, load capacity of the motor control centers, conductors and motors, as well as the tripping characteristics of thermal relays may require modification to reflect these changes due to altitude. Paschen’s Law describes the breakdown voltage of parallel plates in a gas, as a function of pressure and gap distance. In other words, at lower pressure (higher altitudes) it takes less voltage to cross a given distance increasing the chance for electrical arcs. To compensate for this, it is recommended that the operational voltage be de-rated for altitudes exceeding 2,000 meters according to Paschen’s law. In addition, the rated thermal current should also be reduced because of the decreased thermal efficiency of lower density (high altitude) air.

Siemens tiastar Motor Control Centers are designed and built to operate up to 2000 meters above sea level (6,600 ft) without any modifications. Siemens MCC components are designed and manufactured to provide excellent insulation and arc flash protection for bus components, in addition to having high thermal efficiency. Using creative design and engineering, Siemens MCC’s can operate safely and reliably at altitudes up to 5,000 meters above sea level.

Altitude (m)	<2000		2001-3000		3001-4000		4001-5000	
	Voltage	Current	Voltage	Current	Voltage	Current	Voltage	Current
Motor Control Center	Std. Aluminum & Copper 65°C rise horizontal bus				Requires enhanced Copper 50°C rise horizontal bus			
Motor Control Center								
(MCC Bus & Enclosure)	600V	100%	480V	100%	480V	100%	480V	100%
Breakers	600V	100%	480V	97%	480V	94%	480V	91%
Starters								
Innova ¹	600V	100%	480V	97%	480V	94%	480V	91%
Sirius ¹	600V	94%	600V	90%	480V	80%	480V	70%
Soft Starters								
3RW40	460V	89%	460V	75%	460V	70%	460V	63%
3RW44	460V	92%	460V	85%	460V	78%	460V	70%
Drives								
MM440 frame (FXGX)	100%	100%	90%	90%	77%	85%		
MM440 frame (A-F)	100%	90%	90%	85%	77%	80%		
WL Breakers	600V	100%	480V	97%	480V	94%	445V	91%
G120 (FSA...FMF) PM240	100%	92%	88%	86%	77%	80%		
G120 (FSGX) PM240	100%	100%	88%	92%	77%	85%		

The data presented here is subject to change, without notice, owing to periodic updates and corrections. Contact factory for latest information.

¹ ESP200 and/or the 3RB20 overloads are included in the ratings. For SIMOCODE, there is no de-rating required for ≤ 2000 meters. Usage is limited for applications above 2000 meters depending on ambient temperature. For more detail, please see the SIMOCODE Pro System Manual.

NEMA Enclosure Types

Enclosure Types	Indoor or Outdoor	Description
NEMA 1	Indoor	This enclosure is primarily to prevent accidental contact by personnel with the enclosed equipment and for protection against falling dirt. NEMA 12 reset and handle mechanisms are standard for all enclosures.
NEMA 1A	Indoor	This enclosure has the same use as NEMA 1 except the front of the enclosure is gasketed. The parts that are gasketed include: Unit separator angles, Right hand side of front of units, Bottom horizontal cross ties, Lip on top plate, Handle mechanism, and Bottom horizontal wireway cover plate. The whole front of structure is gasketed, except the hinged side of door.
NEMA 2	Indoor	This design is NEMA 1A front with a drip shield mounted on top of the enclosure. This enclosure is to protect equipment against falling noncorrosive liquids and dirt. It prevents the entrance of dripping liquid at a higher level than the lowest live part within the enclosure. The drip shield completely covers the top and extends 3" over the front and 1 1/2" over the sides of the basic structure. On front-only MCC's, the drip shield is flush to the rear. The drip shield is angled from front to rear and not flush with the top of the MCC. The drip shield mounts on the top of the structure.
NEMA 12	Indoor	This enclosure is intended for indoor use in areas where fibers, lint, dust, dirt, and light splashing are prevalent. The NEMA Type 12 enclosure will provide a greater degree of protection than a NEMA 1A enclosure. The following additional parts are gasketed: hinged side of doors, pilot device panel, top plates, wireway end-covers, and rear plates. Because of the divider side sheet assemblies, there is no gap between sections, allowing for much greater dust resistance. In addition, interconnection holes in the side sheet assemblies are sealed. Bottom plates are included when NEMA 12 is specified.
NEMA 3R	Outdoor (Non walk-in)	This enclosure will prevent entrance of rain at a level higher than the lowest live part. The enclosure has provision for locking and drainage. This NEMA 3R enclosure entirely surrounds the motor control center for outdoor operation. Each non walk-in enclosure has a floor and a slanted roof. All doors are louvered and screened to promote air circulation and keep out pests. Motor control units can be racked in positive stop/test position with the outer enclosure doors closed. Rigid steel construction permits use from two sections up to any reasonable number of sections. Stainless steel hinge pins and door stops are standard. Pressure Sensitive Adhesive (PSA) Closed Cell Sponge Rubber door gasket forms a tight seal to keep the elements out. Space heaters, fluorescent lights, fans, filters, blowers, and convenience outlets are available as options. NEMA 3R enclosures are designed to accommodate bottom cable entry and exit only. The enclosures are not intended to provide protection against conditions such as dust, snow, or sleet (ice).

Attention: Variable Frequency Drives require special consideration, see units chapter VFD section for further detail

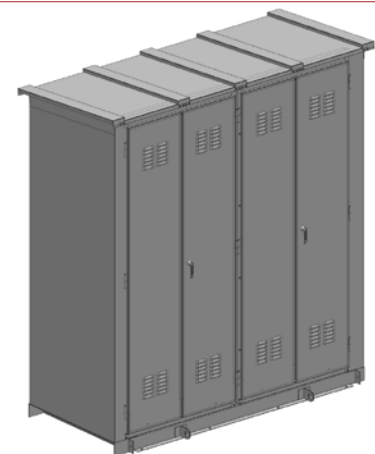

Figure 10.
NEMA 3R
enclosure

Paint and MCC Finish

The motor control finish is an electrostatically applied TGIC-free polyester powder, applied both manually and automatically in an environmentally controlled clean room, cured at 400°F for 20 minutes. All painted parts undergo a five-stage preparation process that includes an alkaline wash, water rinse, iron phosphate wash, water rinse and a non-chrome sealer. The minimum film thickness on external surfaces is 2.0 Mils and the finish passes a 600-hour salt spray test per ASTM B117-94 definitions.

ANSI 61 Light Gray is the standard exterior color. Unit backplates and the rear of the vertical wireway are painted white for improved visibility.

Custom color MCC's are available.



Structure Design and Options

Sections

Heavy 14 gauge steel side sheet assemblies are used for supporting the structure without additional bracing. The front of each side frame has a 180° bend to provide additional rigidity and a smooth edge. Cross channels tie the side frames together. A common sheet is used to provide isolation between adjacent sections. A shipping split will have two outer side sheet assemblies and an inside divider side sheet assembly between sections.

Mounting Sills

Full-length mounting sills are standard for each shipping split. The sills are 3" wide by 1 1/8" high and constructed of 7 gauge steel. They have four holes per section for use with 1/2" (max.) anchor bolts. The sills add additional structural rigidity. The mounting sills are an integral part of the structure and should not be removed.



Structural Parts	
Divider Sheets	14 ga.
Side Sheets	14 ga.
Center Bottom Cross Ties	12 ga.
Rear-Channel (FO)	13 ga.
Channel Sills	7 ga.
Center-Top Channel	13 ga.
Vertical Bus Mounting Angles	14 ga.
Lifting Angles	7 ga.
Rear Covers	16 ga.
Top Plates	13 ga.
End Covers	16 ga.
Separator Angles	12 ga.
Shelf Brackets	10 ga.

Unit Parts	
Top and Bottom Unit Barriers	14 ga.
Back Pan	13 ga. 14 ga.
Side Barrier Plate	18 ga.
Angles	14 ga.
Doors	13 ga. 14 ga.

Note: Arc Resistant MCC metal thickness values will be different on some parts.

Structure Design and Options

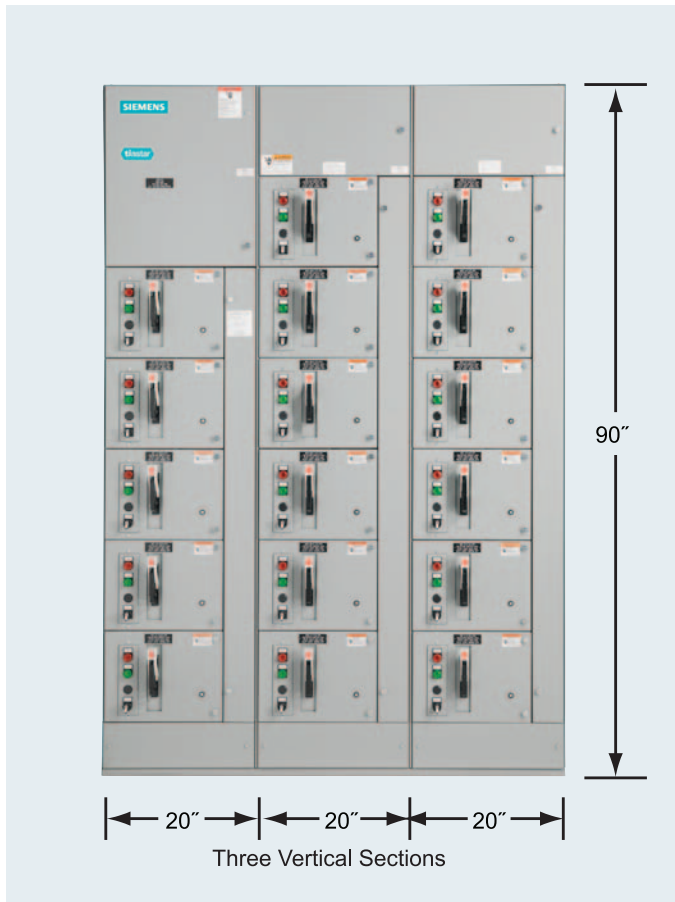

Figure 11. Vertical Section dimensions

Lifting Angle

A 7 gauge lifting angle is supplied with every shipping split regardless of length. The lifting angles are mounted atop the MCC structure.

Side Sheets

Side sheet assemblies on 20" deep units provide a 40.5 square inch wireway opening at the top and a 46 square inch wireway opening at the bottom to facilitate routing wires through the horizontal wireways between adjoining sections. 15" deep units provide a 40.5 square inch wireway opening at the top and a 30 square inch wireway opening at the bottom.

Back-to-Back and Double Deep MCC Options

Usually MCCs are front-mounted. However, for the customers who want to save space and cost, we offer our standard 21" deep back-to-back MCC design. We are the only manufacturer in the market that offers 21" deep back-to-back design with common horizontal and vertical buses.

For customers that would like to have back-to-back configuration but with separate horizontal and separate vertical busses for both the front and rear, double deep MCCs are available with depths of 31" and 41".

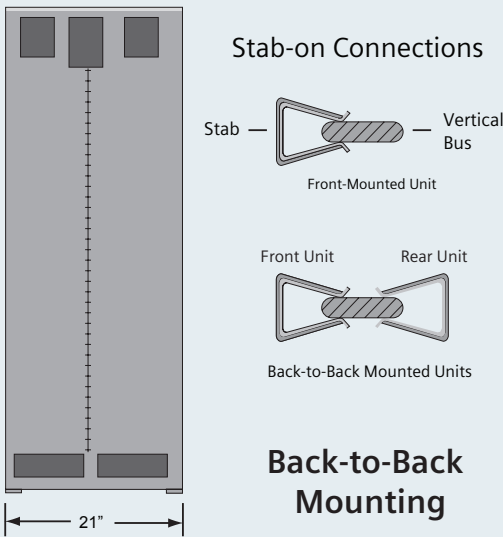

Figure 12. Back-to-Back Configuration

Pull Box (Top Hat) Options

Pull boxes are generally used to provide increased conduit mounting space and additional cable bending space for incoming main feeds instead of bus duct connections. This type of pull box assembly is referred to as a "top hat." Top hats are shipped 12", 18", or 24" high; 20" or 30" wide; 15" or 20" deep for customer field installation on top of MCCs.

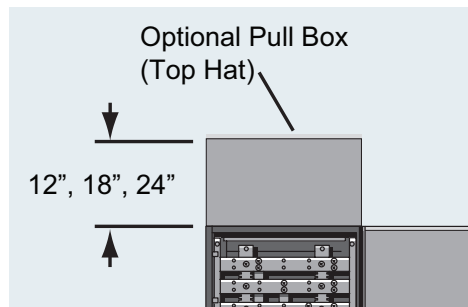

Figure 13. Pull Box Option

Special Structures

30", 40", 50", and 60" wide sections are available for larger units such as large horsepower VFD, RVSS or special panels that may require it. 30" and wider structures may have horizontal bus, but are not supplied with vertical bus. 30" wide structures are available in 15" or 20" deep design and line up with standard 20" wide sections. 30" sections have full-width doors, while wider sections have two interposing doors. Dimensions for other special equipment such as transfer switches, NEMA 3R outdoor enclosures, or special service entrance enclosures will be provided on request.

Bus Selection and Options

For additional strength, the horizontal bus, vertical bus, bus support angles, and bus bracing insulators form one unified assembly.

Horizontal Bus

The horizontal bus is a means of tapping power for distribution to the various units within a section. Siemens tiastar MCC's horizontal bus is always located on the top of the vertical section and never located behind unit space, allowing for easy maintenance and serviceability.

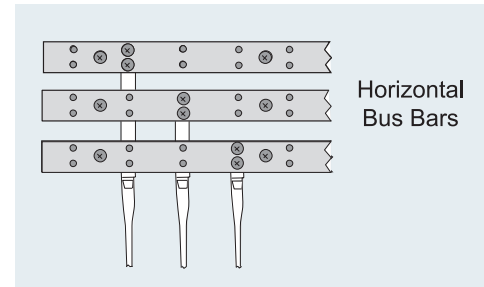

Horizontal Bus Specifications	
Horizontal Bus Current Ratings	600A, 800A, 1200A, 1600A, 2000A, 2500A ¹ only
Horizontal Bus Material Options	Copper with tin or silver plating, or Aluminum ² with tin plating

Vertical Bus

The standard vertical bus is tin-plated copper 3/8" thick with rounded edges. The edges on the vertical bus are rounded to assist in units stabbing onto the bus.

Vertical Bus Specifications	
Vertical Bus Current Ratings	300A, 600A, 800A
Vertical Bus Options	Isolated (standard for 42kA or 65kA bus bracing) Insulated and isolated (optional for 42kA or 65kA bus bracing; standard for 100kA bus bracing and back-to-back) Auto Shutters (standard for the Arc Resistant MCC; optional for all other configurations)
Stab Plating	Tin (standard) Silver (optional)
Bus Bracing	42K AIC, 65K AIC, 100K AIC

¹ NEMA 1 only
² for 600-1200A, 65KA

Vertical Bus (cont)

Vertical buses are available in two designs:

- 1) **Isolated** – Isolated vertical bus design is grounded sheet steel with stab openings and is the standard for front-only structures with 42kA or 65kA bus bracing. The vertical bus bars in this design are not physically insulated phase-to-phase.
- 2) **Insulated and Isolated** – An optional insulated and isolated vertical bus design which prevents arcing faults from propagating is available for front only 42kA and 65kA bus bracing. The isolated and insulated vertical bus design is standard for 100kA bus bracing and all back-to-back structures.

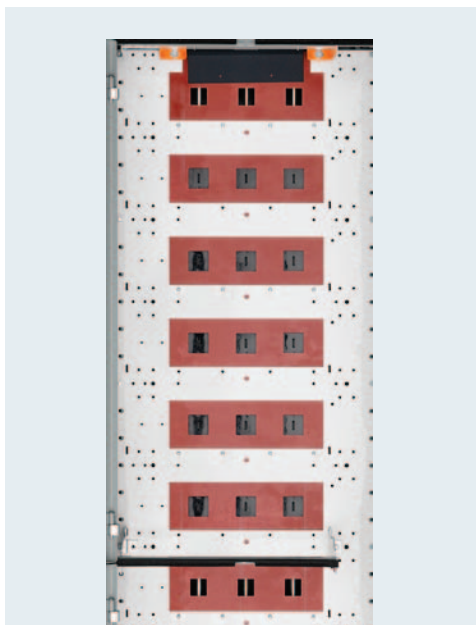

Figure 14. Isolated vertical bus

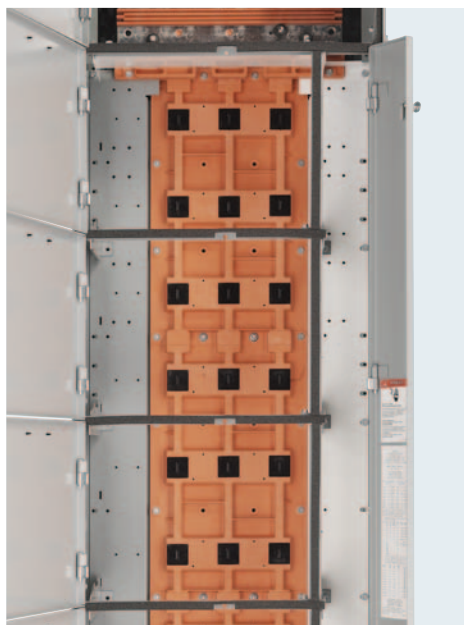

Figure 15. Insulated and Isolated Vertical Bus

Auto Shutter (optional) mechanism automatically opens and closes to allow insertion or removal of units. It prevents inadvertent contact of the vertical bus; thus, lowering the risk to personnel. Auto shutters are available on vertical isolated/insulated busses, however they are a standard on arc resistant MCCs. It is important to point out that the shutter mounting holes are not in the standard bus assembly and cannot be duplicated in the field. Therefore, retrofitting automatic shutters to MCC's that do not have them is not possible.



Bus Selection and Options

Ground Bus

A standard horizontal ground bus is typically mounted in the bottom 6" of the structure. An optional copper 1/4" x 1" vertical ground bus can be connected to the horizontal ground bus. When a combination motor control unit is inserted into the MCC, the optional vertical ground bus is engaged before the vertical power bus. The vertical ground bus provides a means of assuring the plug-in unit is solidly grounded before the power stabs are engaged and remains grounded until the power stabs are disengaged. When vertical ground bus is specified on back-to-back structures, vertical and horizontal ground bus must be supplied in the front and rear of each section.

The ground bus may be located in the top or bottom front of 15" or 20" deep MCCs or the top or bottom rear of back-to-back structures under most situations. A ground lug is supplied on one end of the ground bus as standard or can be optionally added to both ends. If not otherwise specified, the lug will be located in the incoming line section.

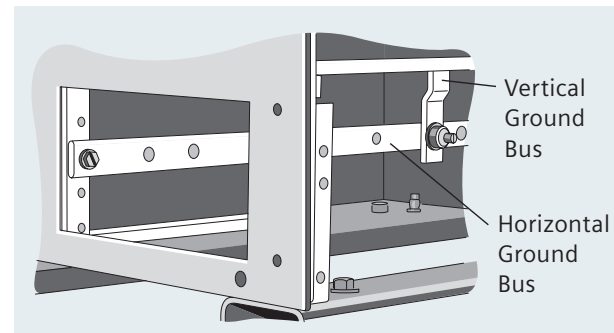

Figure 16. Vertical and Horizontal Ground Bus

Ground Bus ¹		
Horizontal (Bottom Mounted) (A)	300A	Cu
	600A	Cu
	600A	Al
Vertical (A) ²	300A	Cu

1 Standard ground bus is bare copper. Tin or silver plating is optional. Aluminum bus is also optional.

2 Available with motor ground terminations.

Neutral Bus

A neutral connection is generally required for 3 phase 4 wire systems. A neutral pad is usually mounted in the incoming section only. Optionally, a neutral bus running the full length of the line-up can be provided. When full length neutral bus is specified, the neutral bus must be located in the bottom front of the MCC structure. Full length neutral bus requires that the ground bus be mounted in the top of the structure. In general, neutral bus capacity is sized at 1/2 main bus capacity. A two hole lug is supplied as standard when a service entrance label is not required. For service entry, a neutral lug and a bonding lug are supplied. All lugs used for ground or neutral are CU/AL type.

Neutral Bus		
Neutral Bus (Bottom Mounted) (A)	600A	Cu
	800A	Cu
	1200A	Cu
	1600A	Cu

Wireways

Vertical Wireway

The vertical wireway is 72" H x 4" W and has a cross sectional area of 38.25 square inches. An optional 8" W vertical wireway is available with an area of 76.5 square inches.

A vertical wire-way door is supplied on each 20" and 24" wide section that does not contain a 72" tall unit. Vertical wireway doors are not supplied on any section that contains a 72" high unit or on 30" wide or wider structures or 20" wide units.

Each vertical wireway is supplied with three wire tie rods.

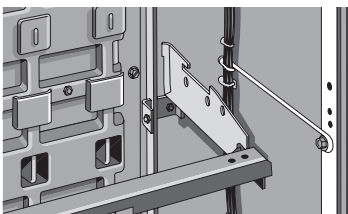

Figure 17. Wire tie rod

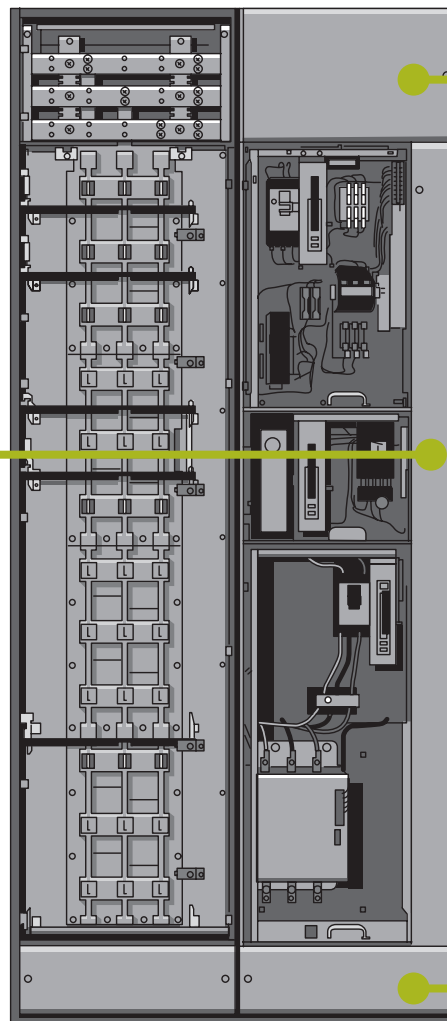

Figure 18. Vertical and Horizontal wireways

The top horizontal wireway is covered with a 12" high full-width door with a 1/4-turn latch. They are 12" high with a cross section of 90 square inches.

Horizontal Wireways are located in the top and bottom of each section and run the full length of each line-up.

The bottom horizontal wireway is 6" high with 45 square inch area.

Rear Wireway

The rear of the structure can be used as a wireway if the available Grommated Vertical Wireway with 2 1/2" grommated holes are specified. Dimensions for rear wireways in front mounting 15" and 20" deep units are:

15" deep: $1\ 1/2" \times 19\ 3/4" = 30\ \text{sq. in.}$ cross sectional area.

20" deep: $9" \times 19\ 3/4" = 178\ \text{sq. in.}$ cross sectional area.

Mains and Incoming Devices

The incoming cables are terminated on lugs in an incoming compartment of the MCC. These lugs may be connected directly to the bus via Main Lug Only (MLO) or connected to a main disconnect device which may either be a Main Circuit Breaker (MCB) or Main Fusible Disconnect (MDS).

It is important to know whether the incoming cables will be coming from the bottom or top of the MCC, as the required wire bending space may affect the compartment size.

Note: All dimensions are shown in inches unless otherwise specified.

Main Lugs: Top or Bottom Entry

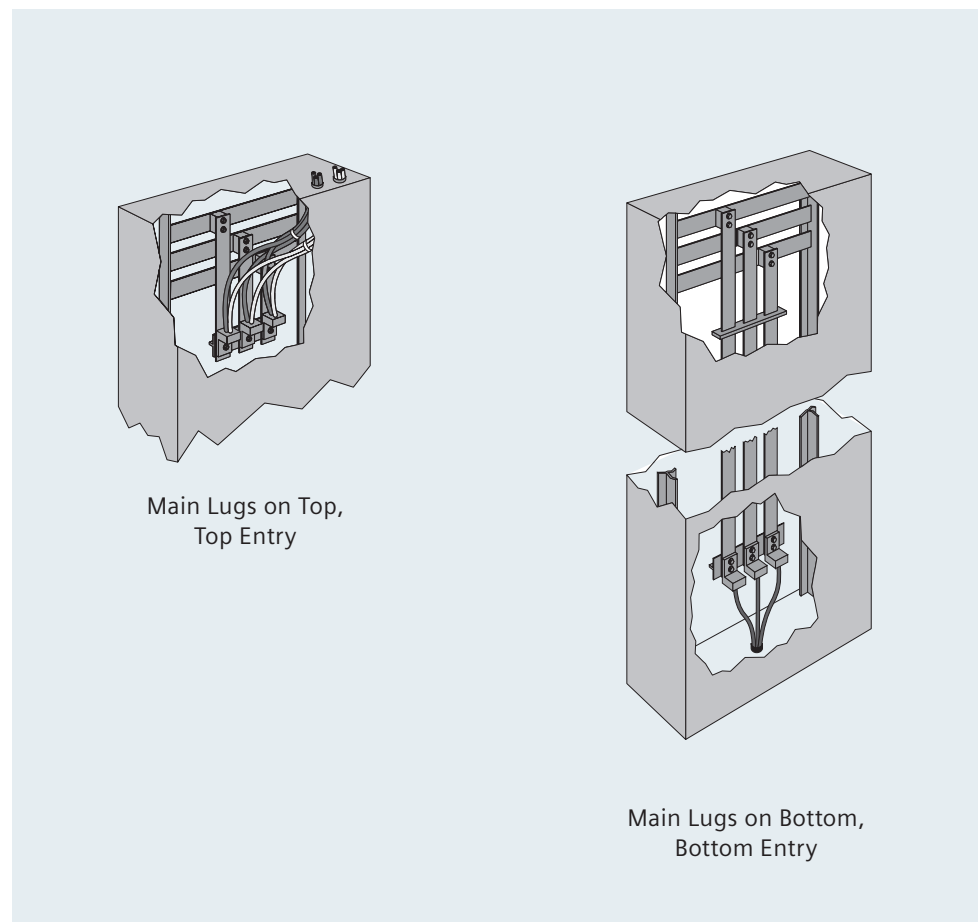
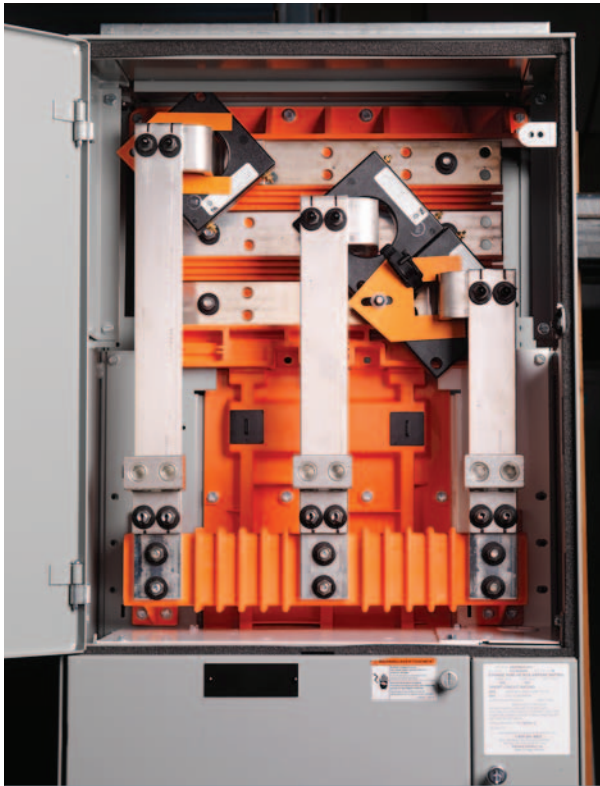

Figure 19. Main Lugs on Top or Bottom Compartment.



Main Lug Only (MLO) Top Feed



Main Circuit Breaker (MCB) Top Feed



Main Lug Only (MLO) Bottom Feed



Main Circuit Breaker (MCB) Bottom Feed

Main Lug Only (MLO)

Horizontal lugs are available with 600A, 42,000A symmetrical bracing only (see Figure 20 on next page).

Special lugs such as NEMA 2-hole compression lugs can be accommodated. Consult Siemens for space requirements.

Amp/Bracing (A/K)	Location	Incoming Cable size	Fig. ref. Next page	Wire bending Space dim. A	Total assembly Height dim. B	Required unit Space dim. C
600A/42K	Top	Qty = 2 #4 - 350kcmil CU	Figure 20	13	12	0
600A/42K-65K	Top	Qty = 2 #2 - 600kcmil CU	Figure 21	16	24	12
600A/85-100K	Top	Qty = 2 #2 - 600kcmil CU	Figure 22	20	30	18
600A/42K ¹	Bottom	Qty = 2 #4 - 350kcmil CU	Figure 23	13	18	12
600A/65K ¹	Bottom	Qty = 2 #4 - 350kcmil CU	Figure 23	13	24	18
800A/42K-65K	Top	Qty = 2 #2 - 600kcmil CU	Figure 21	16	24	12
800A/85K-100K	Top	Qty = 2 #2 - 600kcmil CU	Figure 22	20	30	18
800A/42K-65K ²	Bottom	Qty = 2 #2 - 600kcmil CU	Figure 24	18	30	24
1200A/42K-100K	Top	Qty = 3 #2 - 600kcmil CU	Figure 22	20	30	18
1200A/42K-100K ²	Bottom	Qty = 3 #2 - 600kcmil CU	Figure 24	18	30	24
1600A/42K-100K	Top	Qty = 4 #2 - 600kcmil CU	Figure 22	20	30	18
1600A/42K-100K ²	Bottom	Qty = 4 #2 - 600kcmil CU	Figure 24	18	30	24
2000A/42K-100K	Top	Qty = 6 #2 - 600kcmil CU	Figure 25	29	48	36
2000A/42K-100K	Bottom	Qty = 6 #2 - 600kcmil CU	Figure 26	46	72	72
2500A/42K-100K	Top	Qty = 6 #2 - 600kcmil CU	Figure 25	29	48	36
2500A/42K-100K	Bottom	Qty = 6 #2 - 600kcmil CU	Figure 26	46	72	72

¹ Space behind structure not available.

² Entire rear of structure not available.

Optional lugs available. Contact factory for size and rating.

Incoming line termination arrangements for Main Lug Only (MLO)

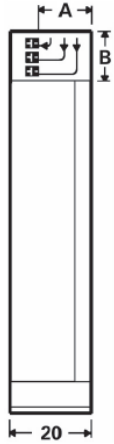

Figure 20.

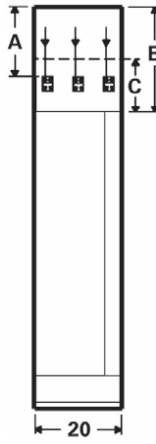

Figure 21.

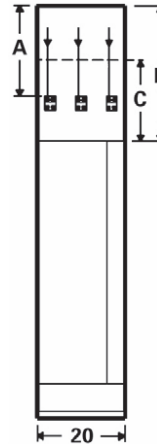

Figure 22.

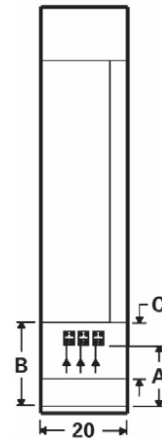

Figure 23.

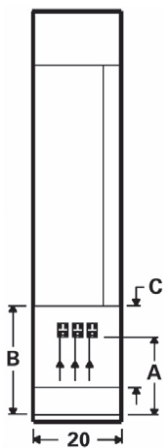

Figure 24.

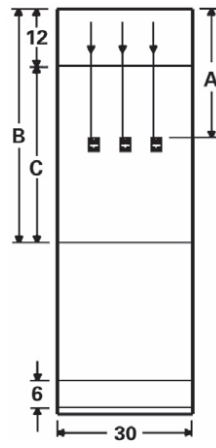

Figure 25.

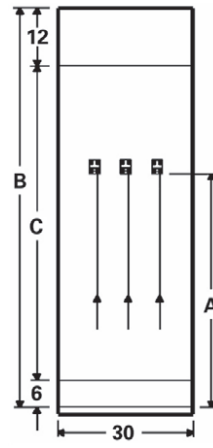
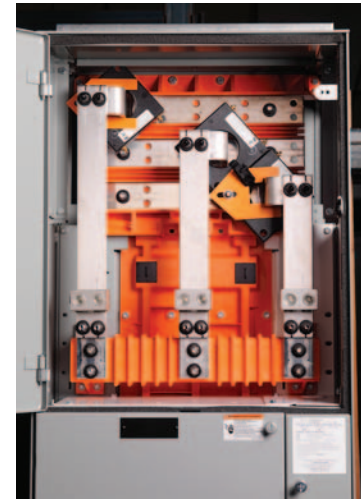

Figure 26.



Example:
MLO Top Feed

Main Circuit Breaker (MCB)

Molded Case Thermal Magnetic circuit breakers, Molded Case Solid State circuit breakers, and Insulated Case WL Power circuit breakers can be used as mains in the MCC. These circuit breakers are 80% rated, however 100% rated options are also available (see below).

Circuit Breaker Frame	Location	Incoming Cable size	Fig. ref. Next page	Wire bending Space dim. A	Total assembly Height dim. B	Required unit Space dim. C
125A	Top	Qty = 1 ⁵ #3 - 3/0 CU	Figure 27	14	24	12
125A	Bottom	Qty = 1 ⁵ #3 - 3/0 CU	Figure 30	8	24	18
250A	Top	Qty = 1 #6 - 350kcmil CU	Figure 28	15	30	18
250A	Bottom	Qty = 1 #6 - 350kcmil CU	Figure 31	15	36	30
400A ^{7 8}	Top	Qty = 1 #6 - 350kcmil CU	Figure 28	15	30	18
400A ^{7 8}	Bottom	Qty = 2 3/0 - 500kcmil CU	Figure 32	15	42	36
600A ^{7 8}	Top	Qty = 2 3/0 - 500kcmil CU	Figure 28	15	30	18
600A ^{7 8}	Bottom	Qty = 2 3/0 - 500kcmil CU	Figure 32	15	42	36
800A ^{1 8}	Top	Qty = 3 #1 - 500kcmil CU	Figure 29	22	48	36
800A ^{2 6 8}	Bottom	Qty = 3 #1 - 500kcmil CU	Figure 33	22	54	48
1200A ^{1 8}	Top	Qty = 4 250 - 500kcmil CU	Figure 29	22	48	36
1200A ^{2 3 6 8}	Bottom	Qty = 4 250 - 500kcmil CU	Figure 33	22	54	48
1600A ^{3 8}	Top	Qty = 4 300 - 600kcmil CU	Figure 36	30	90	72
1600A ^{3 8}	Bottom	Qty = 4 300 - 600kcmil CU	Figure 37	30	90	72
2000A ³	Top	Qty = 6 300 - 600kcmil CU	Figure 34	32	90	72
2000A ³	Bottom	Qty = 6 300 - 600kcmil CU	Figure 37	26	90	72
800A ⁴	Top	Qty = 2 #1 - 600kcmil CU	Figure 32	28	90	72
800A ⁴	Bottom	Qty = 2 #1 - 600kcmil CU	Figure 33	25	90	72
1200A ⁴	Top	Qty = 4 250 - 600kcmil CU	Figure 32	28	90	72
1200A ⁴	Bottom	Qty = 4 250 - 600kcmil CU	Figure 33	25	90	72
1600A ⁴	Top	Qty = 4 300 - 600kcmil CU	Figure 34	28	90	72
1600A ⁴	Bottom	Qty = 4 300 - 600kcmil CU	Figure 35	25	90	72
2000A ⁴	Top	Qty = 6 300 - 600kcmil CU	Figure 34	28	90	72
2000A ⁴	Bottom	Qty = 6 300 - 600kcmil CU	Figure 35	25	90	72
2500A ⁴	Top	Qty = 6 300 - 600kcmil CU	Figure 34	28	90	72
2500A ⁴	Bottom	Qty = 6 300 - 600kcmil CU	Figure 35	25	90	72

1 Space in rear of structure not available
 2 Entire rear of structure not available
 3 Molded case circuit breakers
 4 WL power circuit breakers

5 15-25A lug size 12-10 AL, 14-10 CU; 30-100A, 10-1/0 CU
 6 800A - 1200A not available in back-to-back bottom mounting

7 Stab opening at bottom of unit not available in rear
 8 100% rated circuit breaker option available; unit size may increase
 Optional lugs available. Contact factory for size and rating.
 Note: All circuit breakers are calibrated for 40° C.

Incoming line termination arrangements for Main Circuit Breaker (MCB)

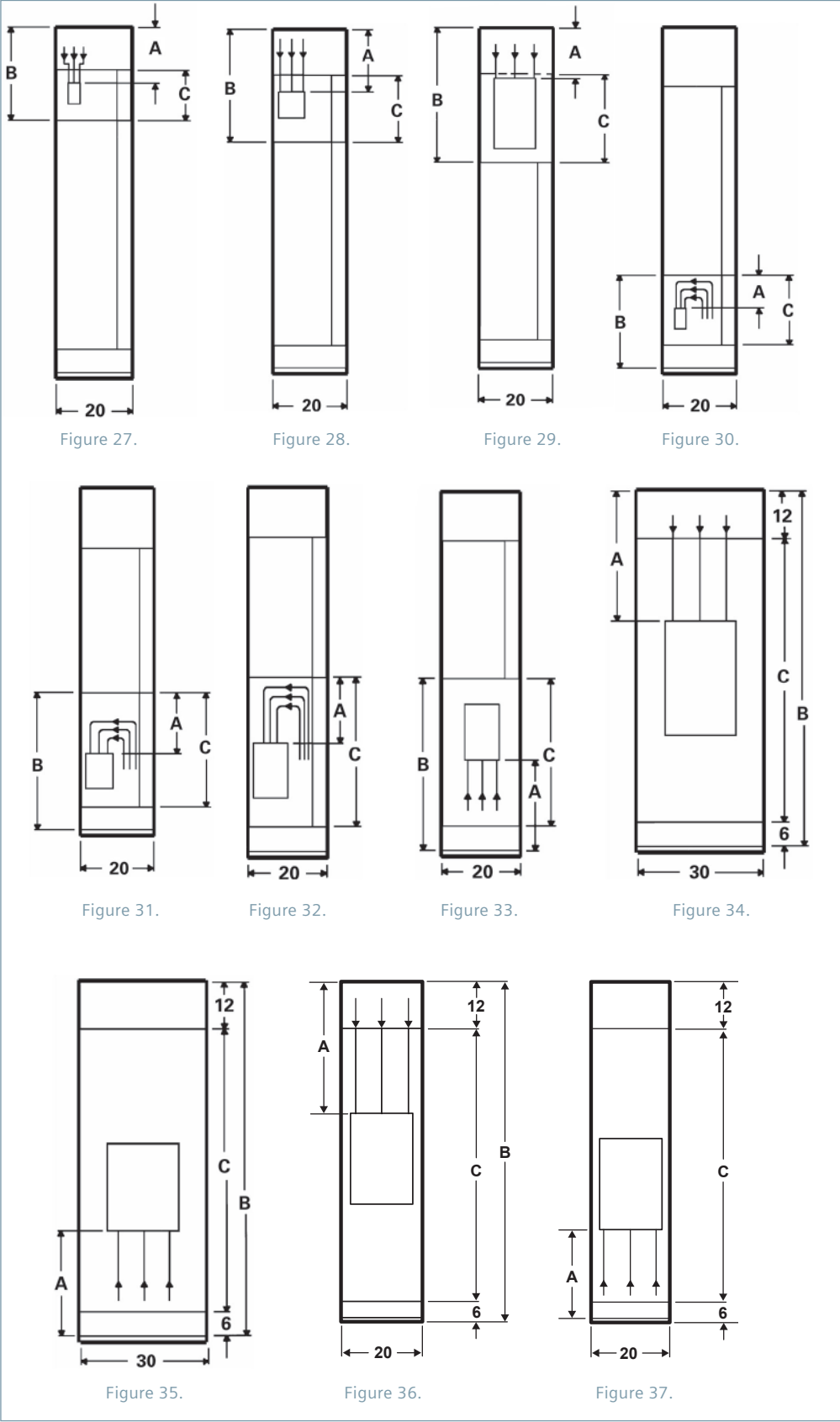

Example:
MCB Top Feed

Main Disconnect Switch (MDS)

Main fusible switches consist of the following:

- 60 to 100A, Class R fuse clips
- 200 to 600A, Class R fuse holder
- 800 to 1200A, Class L fuse holder

Fusible disconnect Switch/clips	Location	Incoming Cable size	Fig. ref. Next page	Wire bending Space dim. A	Total assembly Height dim. B	Required unit Space dim. C
60A/30A or 60A	Top	Qty = 1 #14 - #14 CU	Figure 38	14	24	12
60A/30A or 60A	Bottom	Qty = 1 #14 - #14 CU	Figure 43	8	24	18
100A/100A	Top	Qty = 1 #14 - #14 CU	Figure 39	13	30	18
100A/100A	Bottom	Qty = 1 #14 - #14 CU	Figure 44	7	30	24
200A/200A	Top	Qty = 1 #6 - 350kcmil CU	Figure 40	16	42	30
200A/200A	Bottom	Qty = 1 #6 - 350kcmil CU	Figure 45	10	48	42
400A/400A	Top	Qty = 2 3/0 - 500kcmil CU	Figure 41	14	48	36
400A/400A	Bottom	Qty = 2 3/0 - 500kcmil CU	Figure 46	14	60	54
600A/600A	Top	Qty = 2 3/0 - 500kcmil CU	Figure 41	14	48	36
600A/600A	Bottom	Qty = 2 3/0 - 500kcmil CU	Figure 46	14	60	54
800A/800A ¹	Top	Qty = 3 250-500kcmil CU	Figure 48	22	90	72
800A/800A ¹	Bottom	Qty = 3 250-500kcmil CU	Figure 47	22	90	72
1200A/1200A ¹	Top	Qty = 4 250-500kcmil CU	Figure 48	22	90	72
1200A/1200A ¹	Bottom	Qty = 4 250-500kcmil CU	Figure 47	22	90	72

¹ Space in rear of structure not available.
Optional lugs available. Contact factory for size and rating.

Incoming line termination arrangements for Main Disconnect Switches (MDS)

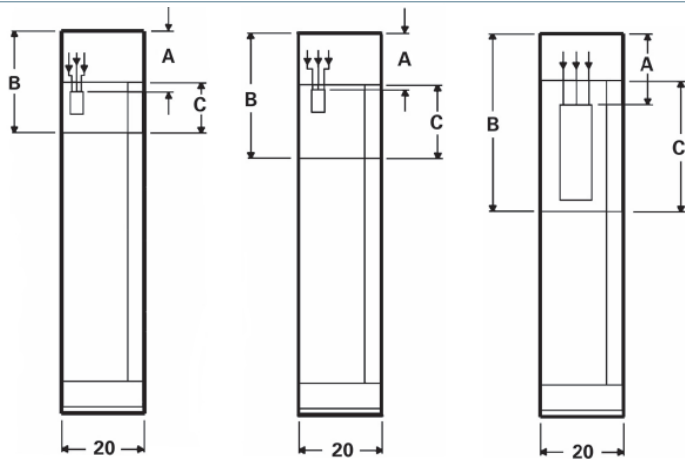

Figure 38.

Figure 39.

Figure 40.

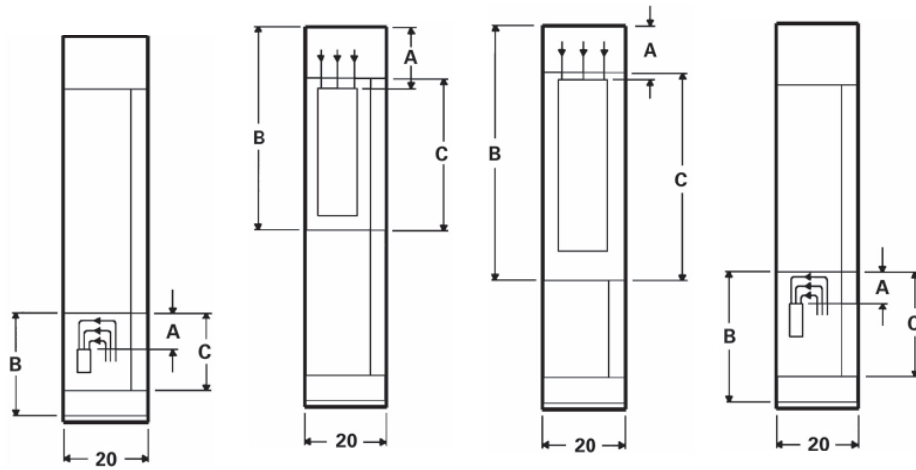

Figure 41.

Figure 42.

Figure 43.

Figure 44.

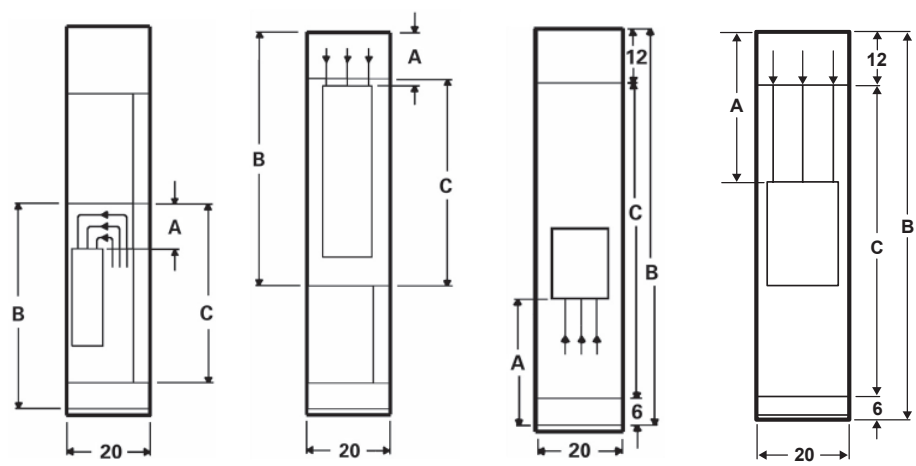

Figure 45.

Figure 46.

Figure 47.

Figure 48.

Feeders



Example of Feeder Circuit Breaker (FCB)



Example of Dual Feeder Disconnect Switch (DFDS)

Feeder Circuit Breakers Space Requirements

Frame Size (Amps)	Max Trip Amps	Unit Height (Inches)	
		1 CB	2 CB
125	125	12 ¹	12 ¹
250	250	18 ²	—
400	400	24 ^{3,5}	—
600	600	24 ^{3,5}	—
800	800	36 ³ (Top)	—
800	800	48 ³ (Bottom)	—
1200	1200	36 ³ (Top)	—
1200	1200	48 ³ (Bottom)	—

Feeder Circuit Breakers High Density

Trip Amps	Unit Height (Inches)
	1 CB
15-250	6
150-250	12

Feeder Disconnect Switch Space Requirements

Switch Rating (Amps)	Fuse Clip Size (Amps)	Unit Height (Inches)	
		1 SW	2 SW
30	30	12 ⁴	12 ⁴
60	60	12 ⁴	12 ⁴
100	100	18	—
200	200	30	—
400	400	42 ^{3,5}	—
600	600	42 ^{3,5}	—

1 CED Current Limiting Breaker requires 18"

2 CFD Current Limiting Breaker requires 24"

3 Fixed mounted unit.

4 Requires load terminal blocks.

5 Stab opening at top of unit not available in rear.

Feeder Disconnect Switch Ratings

Disconnect Size	Disconnect ² Type	Fuse Type	Rating
30	MCS	R,J	100KA
60	MCS	R,J	100KA
100	MCS	R,J	100KA
200	MCS	R,J	100KA
400	JXDS	R,J	100KA
600	LXDS	R,J	100KA
800	MXDS	L	100KA
1200	NXDS	L	100KA

Feeder Circuit Breaker Ratings

Type	Frame	Ratings in KA		
		240V	480V	600V
ED6	125	65	25	18
LGG	125	65	65	—
HED4	125	100	42	—
CED6	125	100	100	100
HDG	150	100	65	20
FD6	250	65	35	22
HFD6	250	100	65	25
HHFD6	250	100	65	25
CFD6	250	100	100	100
HFG	250	100	65	20
JD6	400	65	35	25
HJD6	400	100	65	35
HHJD6	400	100	100	50
SCJD6	400	100	100	100
LD6	600	65	35	25
HLD6	600	100	65	35
HHLD6	600	100	100	50
SCLD6	600	100	100	100
MD6	800	65	50	25
HMD6	800	100	65	50
CMD6	800	100	100	65
SMD6	800	65	50	25
SHMD6	800	100	65	50
SCMD6	800	100	100	65
WLS208	800	65	65	65
WLL208	800	100	100	85
ND6	1200	65	50	25
HND6	1200	100	65	50
CND6	1200	100	100	65
SND6	1200	65	50	25
SHND6	1200	100	65	50
SCND6	1200	100	100	65
WLS212	1200	65	65	65
WLL212	1200	100	100	85
PD6	1600	65	50	25
HPD6	1600	100	65	50
CPD6	1600	100	100	65
WLS216	1600	65	65	65
WLL216	1600	100	100	85
RD6	2000	65	50	25
HRD6	2000	100	65	50
WLS220	2000	65	65	65
WLL220	2000	100	100	85

Breakers listed are rated to the UL489 standard.
 Note: All circuit breakers are calibrated for 40° C.

Standard Disconnects

Standard fusible units use the following disconnects:

Siemens Visible Blade 30 - 200A

Siemens Molded Case Switch 400, 600A

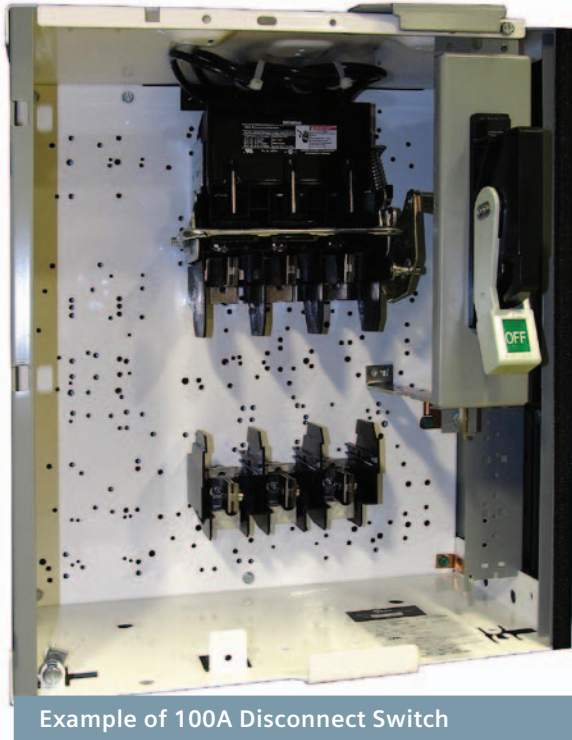

Example of 100A Disconnect Switch



Example of 400A Molded Case Switch

Bus Splice & Bus Duct

Bus links are available for connection to existing tiastar/system 89 MCC. The following information is needed for each order:

- a. Style No. of existing MCC
- b. Left or right connection to new MCC order
- c. Ampacity of existing bus (example: 600A, 800A, etc.)
- d. Size of existing ground and neutral bus

Note: For some MCCs (Model 90 and Model 95), a transition arrangement may be necessary.

Bus duct connections are supplied on request. They may require a pull box or a special structure depending on the application. Complete bus stub dimensions, bus run drawings, and specification must be supplied.

Splice Kits

Note: For complete splice kit installation details, refer to instructions supplied with splice kits.

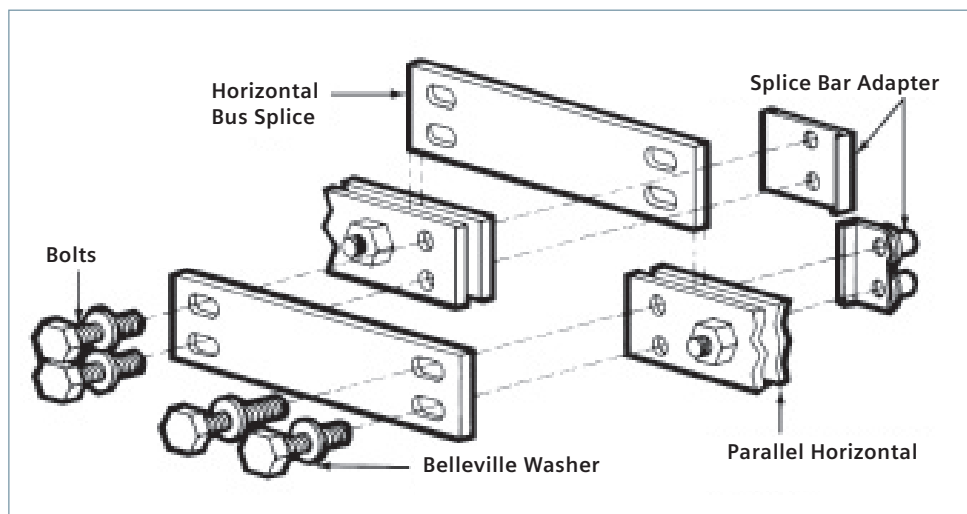

Figure 49. Exploded View of Splice Kit

Splice Kits

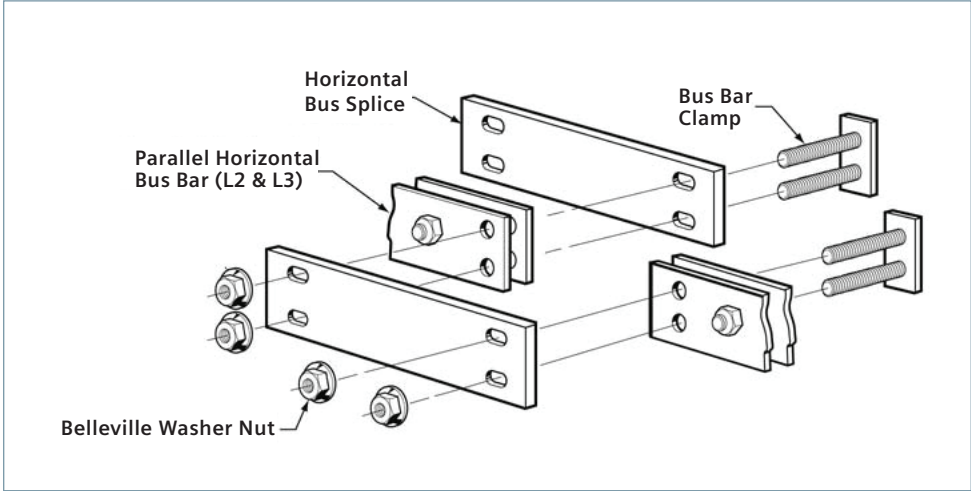

Figure 50. 1200, 1600A L2 and L3 Connection

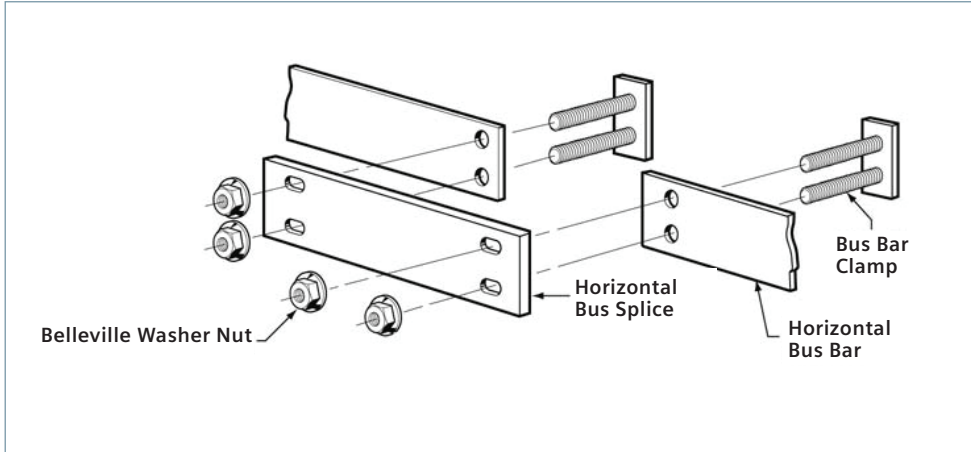

Figure 51. 1200A, 1600A Neutral Bus Connection

TPS3 Surge Protective Devices (SPD)

Siemens Integral TPS3s are UL 1449 4th Edition, factory installed SPDs within our MCCs, utilizing optimal electrical system connections to minimize impedance losses. This results in the some of the industry's best "installed" Voltage Protection Ratings. This SPD has the following features:

- UL 1449 4th Edition and UL 1283
- UL 1449-4 Type 2 SPD, UL 1283 Listed, CSA 22.2 No. 269.2, Optional UL 1449 4th Edition Recognized Type 1, CSA 22.2
- 20 kA I_n (most models)
- 200 kA SCCR (most models)
- UL96A Lightning Protection Master Label Compliant
- 100 –300 kA surge current capacity per phase
- EMI/RFI filtering or Sine Wave tracking
- Standard Monitoring –LEDs, Audible Alarm, Dry Contacts, Surge Counter, and Ground References Monitoring (GRM) Diagnostics.
- 10 year product warranty



Notes

Plug-in Unit Features

All plug-in unit of the same size are interchangeable and can be relocated elsewhere in the motor control center. Unit compartment heights may be modified in the field to accept different size units.

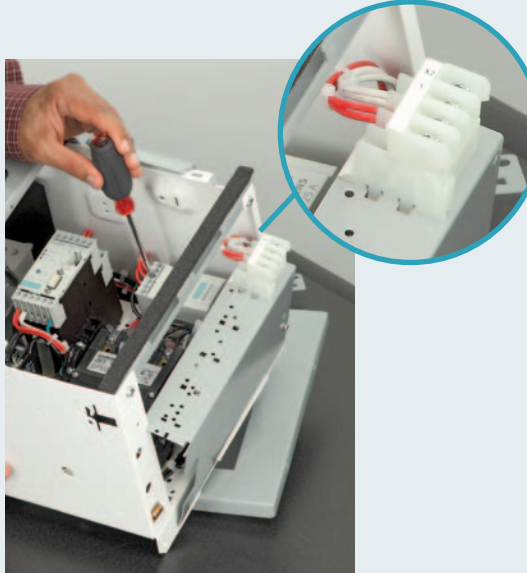
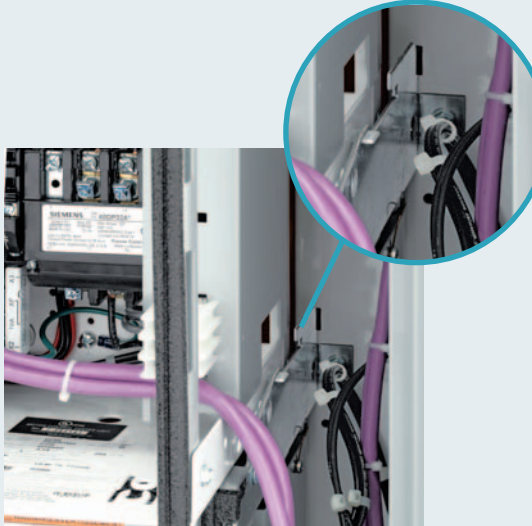
Benefits		Feature
<p><i>Ease in wiring and inspection</i></p>		<p>Terminal blocks are mounted on a swing-out side barrier.</p>
<p><i>Indicates that a plug-in unit is fully withdrawn from the vertical bus and prevents the unit from falling out of the structure during unit removal.</i></p>		<p>A positive stop in the "TEST" position.</p>

Benefits

Feature

Engages and grounds units at all times.



Copper ground clip on plug-in unit.

Easy unit access and removed.



All doors swing open a minimum of 110°.

Allows lockout/tagout procedures to be implemented at the unit level. Putting the unit in the stop position allows for lock out tag out procedure to be implemented.



Safety lock capabilities.

Combination Starters

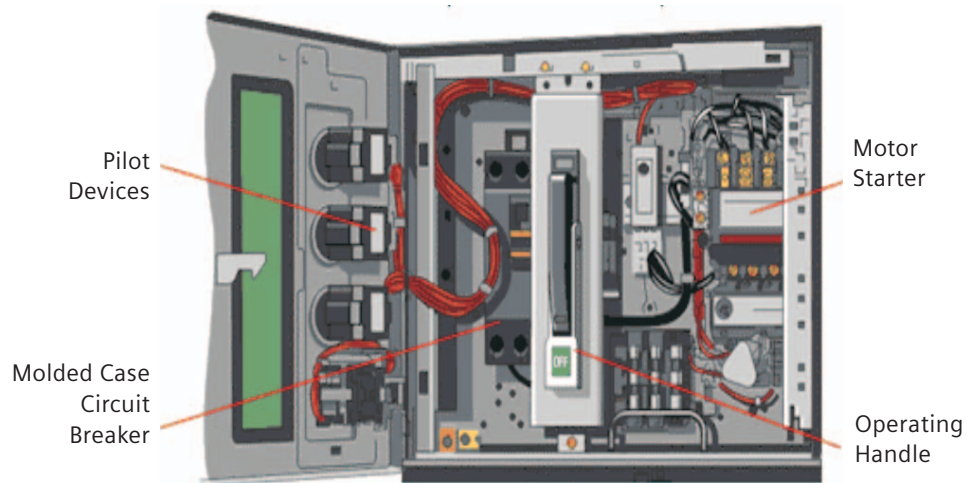

Figure 52. 1200A, 1600A Neutral Bus Connection

A combination starter is the grouping of a motor starter with a fuse or circuit breaker disconnect. Plug-in units in a structure are connected to the vertical bus by a stab assembly on the back of the unit. The stab assembly is then wired to a disconnect device inside the plug-in unit. Power then flows through the circuit breaker, through the motor starter, and ultimately to the motor.

NEMA Size	Description
0 - 4	Siemens Heavy Duty NEMA Magnetic Starters and Contactors (Standard)
1 - 4	Sirius NEMA Rated Contactors (Optional)
5, 6	Sirius NEMA Rated Contactors (Standard)
4, 5, 6	Sirius Vacuum Contactors (Optional)

Stabs

The power stabs engage the vertical power distribution bus when the units are installed in the structure. Plug-in tin plated copper (standard) unit stab assemblies include self-aligning stab clips with spring steel backup springs. Wires from the stab clips to the line-side of the circuit breaker or disconnect switch are contained in the stab housing and are isolated phase-to-phase until the wires enter the MCC.



Full Voltage Non-Reversing (FVNR) Unit and Full Voltage Reversing (FVR) with Fusible Switch or Circuit Breaker



Example of Full Voltage Non-Reversing (FVNR)

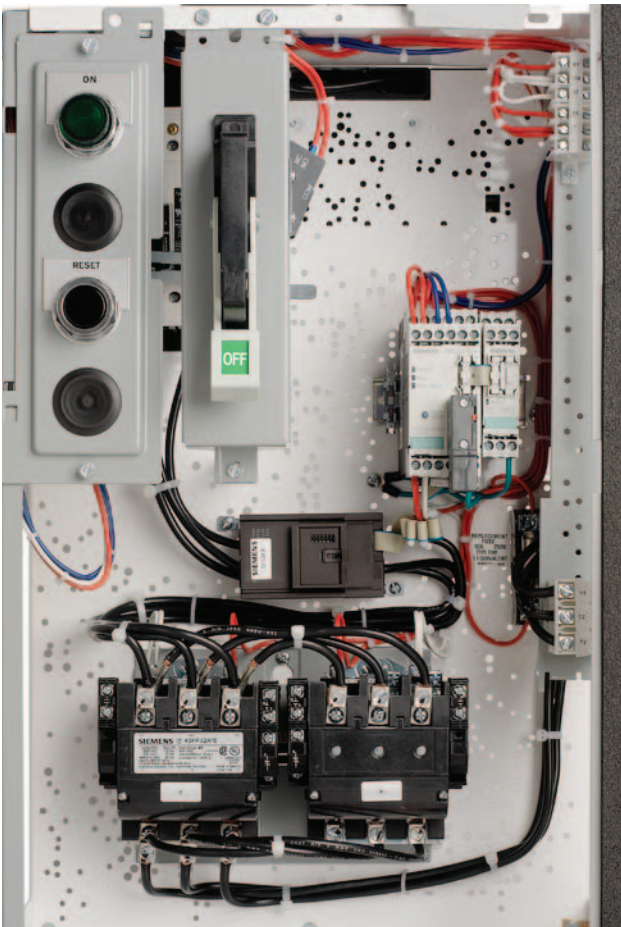

Example of Full Voltage Reversing (FVR)

Full Voltage Non-Reversing (FVNR) Unit and Full Voltage Reversing (FVR) with Circuit Breaker or Fusible Switch

NEMA Size	Maximum Horsepower Rating					Circuit Breaker Type				kA Interrupting Rating at 480V ²
	208V	230V	400V	480V	600V	Standard Breaker Type	MCP Frame Size (Amps)	Dimensions in inches (mm) Unit Height ¹ W = Width, D = Depth		
								FVNR	FVR	
1	7.5	7.5	10	10	10	MCP	125	12 (305)	18 (457)	42 (standard) / 100 (optional)
2	10	15	25	25	25			12 (305)	24 (610)	
3	25	30	50	50	50			18 (457)	30 (762)	
4	40	50	75	100	100		125/250	24 (610)	36 (914)	
5	75	100	150	200	200		250/400	36 (914)	48 (1219)	
6 ³	150	200	300	400	400		400/600/800	48 (1219)	72 (1829) 30W (762W)	
7 ³	—	—	—	600	600	ND6 ⁴	1200	72 (1829) 20W x 20D (508W x 508D)	N/A	42 / 65

1 The addition of oversized CPTs, relays, timers, etc. may increase unit height.

2 For other available voltage ratings, consult Siemens

3 Fixed mounted units (not plug-in)

4 Thermal magnetic breaker (not MCP)

Full Voltage Contactor (FVC) Unit with Circuit Breaker or Fusible Switch

NEMA Size	Maximum KW Resistance Heating Loads					Circuit Breaker Type			Fusible Type (For Maximum KW at 480V)			
	208V	230V	400V	480V	600V	Circuit Breaker Frame Size (Amps)	Dimensions in inches (mm) Unit Height ¹	kA Interrupting Rating at 480V ²	Fusible Switch / Fuse Clip (Amps)	Dimensions in inches (mm) Unit Height ¹ W = Width, D = Depth	kA Interrupting Rating at 480V ²	
1	10.8	11.9	18.7	23.8	31	125	12 (305)	100	30 / 30	12 (305)	100	
2	16.2	17.9	31.2	35.8	46.7	125	12 (305)		60 / 60	12 (305)		
3	32	35	62	71	93	125	18 (457)		100 / 100	24 (610)		
4	48	54	94	107	140	125 / 250	24 (610)		200 / 200	42 (1067)		
5	108	119	206	238	311	250 / 400	36 (914)		JXD6 MCS / 400	60 (1524)		
6 ³	198	218	346	437	570	600	48 (1219)		LXD6 MCS / 600	72 (1829)		
						800	72 (1829)	MXD6 MCS / 800	72 (1829) 30W (762W)			
7 ³	259	286	476	572	747	1200	72 (1829)	65	NXD6 MCS / 1200	72 (1829) 50W x 20D (1270W x 508D)		

1 The addition of oversized CPTs, relays, timers, etc. may increase unit height.

2 For other available voltage ratings, consult Siemens

3 Fixed mounted units (not plug-in).

Fusible Type (For Maximum HP at 480V), Type				NEMA Size
Fusible Switch/ Fuse Clip (Amps)	Dimensions in inches (mm) Unit Height ¹ W = Width, D = Depth		kA Interrupting Rating at 480V ²	
	FVNR	FVR		
30 / 30	12 (305)	18 (457)	100	1
60 / 60	12 (305)	24 (610)		2
100 / 100	24 (610)	36 (914)		3
200 / 200	42 (1067)	48 (1219)		4
JD6 MCS / 400	60 (1524)	60 (1524)		5
MD6 MCS / 800	72 (1829)	72 (1829) 30W (762W)		6 ³
ND6 MCS / 1200	72 (1829)	N/A		7 ³
	40W x 20D (1016W x 508D)			

Dual Full Voltage Non-Reversing (DFVNR) Unit with Circuit Breaker

NEMA Size	Maximum Horsepower Rating					Circuit Breaker Type			
	208V	230V	400V	480V	600V	Standard Breaker Type	MCP Frame Size	Dimensions in inches (mm) Unit Height ¹	kA Interrupting Rating at 480V ²
1	7.5	7.5	10	10	10	MCP	125	18 (457)	100

¹ The addition of oversized CPTs, relays, timers, etc. may increase unit height.

² For other available voltage ratings, consult Siemens

Two Speed One Winding (2S1W) and Two Speed Two Winding (2S2W) with Circuit Breaker or Fusible Switch

Constant or Variable Torque

NEMA Size	Maximum Horsepower Rating					Circuit Breaker Type				
	208V	230V	400V	480V	600V	Standard Breaker Type	MCP Frame Size (Amps)	Dimensions in inches (mm) Unit Height ¹ W=Width, D=Depth		kA Interrupting Rating at 480V ²
								2S1W	2S2W	
1	7.5	7.5	10	10	10	MCP	125	24 (610)	24 (610)	42 (standard) / 100 (optional)
2	10	15	25	25	25			24 (610)	24 (610)	
3	25	30	50	50	50			48 (1219)	36 (914)	
4	40	50	75	100	100		125 / 250	60 (1524)	48 (1219)	
5 ³	75	100	150	200	200		250 / 400	72 (1829) 30W (762W)	72 (1829) 30W (762W)	
6 ³	150	200	300	400	400		600 / 800	Consult Siemens	72 (1829) 30W (762W)	

1 The addition of oversized CPTs, relays, timers, etc. may increase unit height.

2 For other available voltage ratings, consult Siemens

3 Fixed mounted units (not plug-in).

Constant Horsepower

NEMA Size	Maximum Horsepower Rating					Circuit Breaker Type				
	208V	230V	400V	480V	600V	Standard Breaker Type	MCP Frame Size (Amps)	Dimensions in inches (mm) Unit Height ¹ W = Width, D = Depth		kA Interrupting Rating at 480V
								2S1W	2S2W	
1	5	5	7.5	7.5	7.5	MCP	125	24 (610)	24 (610)	42 (standard) / 100 (optional)
2	7.5	10	20	20	20			24 (610)	24 (610)	
3	20	25	40	40	40			36 (914)	30 (762)	
4	30	40	50	75	75		125 / 250	48 (1219)	36 (914)	
5 ³	60	75	100	150	150		250 / 400	72 (1829) 30W (762W)	72 (1829) 30W (762W)	
6 ³	100	150	200	300	300		400 / 600	Consult Siemens	72 (1829) 30W (762W)	

1 The addition of oversized CPTs, relays, timers, etc. may increase unit height.

2 For other available voltage ratings, consult Siemens

3 Fixed mounted units (not plug-in).

Fusible Type (For Maximum HP at 480V)				NEMA Size
Fusible Switch/ Fuse Clip (Amps)	Dimensions in inches (mm) Unit Height ¹ W = Width, D = Depth		kA Interrupting Rating at 480V ²	
	2S1W	2S2W		
30 / 30	24 (610)	24 (610)	100	1
60 / 60	24 (610)	24 (610)		2
100 / 100	36 (914)	30 (762)		3
200 / 200	48 (1219)	36 (914)		4
JD6	72 (1829)	72 (1829)		5 ³
MCS / 400	30W (762W)	30W (762W)		
MD6	Consult Siemens	72 (1829)		6 ³
MCS / 800		40W (1016W)		

Fusible Type (For Maximum HP at 480V)				NEMA Size
Fusible Switch / Fuse Clip (Amps)	Dimensions in inches (mm) Unit Height ¹ W = Width, D = Depth		kA Interrupting Rating at 480V ²	
	2S1W	2S2W		
30 / 30	24 (610)	24 (610)	100	1
60 / 60	24 (610)	24 (610)		2
100 / 100	48 (1219)	36 (914)		3
200 / 200	60 (1524)	48 (1219)		4
JD6 MCS /	72 (1829)	72 (1829)		5 ³
400	30W (762W)	30W (762W)		
MD6 MCS /	Consult Siemens	72 (1829)		6 ³
800		40W (1016W)		

Reduced Voltage Autotransformer (RVAT) Non-Reversing with Circuit Breaker or Fusible Switch—Closed Transition

NEMA Size	Maximum Horsepower Rating					Circuit Breaker Type		
	208V	230V	400V	480V	600V	Standard Breaker Type	Dimensions in inches (mm) Unit Height ¹ W = Width, D = Depth	kA Interrupting Rating at 480V ²
2	10	15	25	25	25	MCP	42 (1067)	42 (standard) / 100 (optional)
3	25	30	50	50	50		42 (1067)	
4	40	50	75	100	100		48 (1219)	
5 ³	75	100	150	200	200		72 (1829), 30W (762W)	
6 ³	150	200	300	400	400		72 (1829), 30W (762W)	
7 ³	—	—	—	600	600	ND6 ⁴	Consult Siemens	42 / 65

1 The addition of oversized CPTs, relays, timers, etc. may increase unit height.

2 For other available voltage ratings, consult Siemens

3 Fixed mounted units (not plug-in)

4 Thermal magnetic breaker (not MCP)

Reducing Voltage Wye Delta Closed (YDC) Transition and Reducing Voltage Wye Delta Open (YDO) Transition

NEMA Size	Maximum Horsepower Rating					Circuit Breaker Type			
	208V	230V	400V	480V	600V	Standard Breaker Type	Dimensions in inches (mm) Unit Height ¹ W = Width, D = Depth		kA Interrupting Rating at 480V ²
							YDO	YDC	
2	20	25	25	40	40	MCP	30 (762)	42 (1067)	42 (standard) / 100 (optional)
3	25	30	50	75	75		36 (914)	48 (1219)	
4	60	60	75	150	150		36 (914)	48 (1219)	
5 ³	150	150	150	300	300		72 (1829) 30W (762W)	72 (1829) 30W (762W)	

1 The addition of oversized CPTs, relays, timers, etc. may increase unit height.

2 For other available voltage ratings, consult Siemens

3 Fixed mounted units (not plug-in)

Fusible Type (For Maximum HP at 480V)			NEMA Size
Fusible Switch / Fuse Clip (Amps)	Dimensions in inches (mm) Unit Height ¹ W = Width, D = Depth	kA Interrupting Rating at 480V ²	
60 / 60	42 (1067)	100	2
100 / 100	48 (1219)		3
200 / 200	60 (1524)		4
JD6 MCS / 400	72 (1829), 30W (762W)		5 ³
MD6 MCS / 800	72 (1829), 30W (762W)		6 ³
ND6 MCS / 1200	Consult Siemens		7 ³

Fusible Type (For Maximum HP at 480V)			NEMA Size	
Fusible Switch / Fuse Clip (Amps)	Dimensions in inches (mm) Unit Height ¹ W = Width, D = Depth			kA Interrupting Rating at 480V ²
	YDO	YDC		
100 / 100	36 (914)	48 (1219)	100	2
200 / 200	48 (1219)	60 (1524)		3
JD6 MCS / 400	72 (1829)	72 (1829)		4
LD6 MCS / 600	72 (1829)	72 (1829)		5 ³
	30W (762W)	30W (762W)		

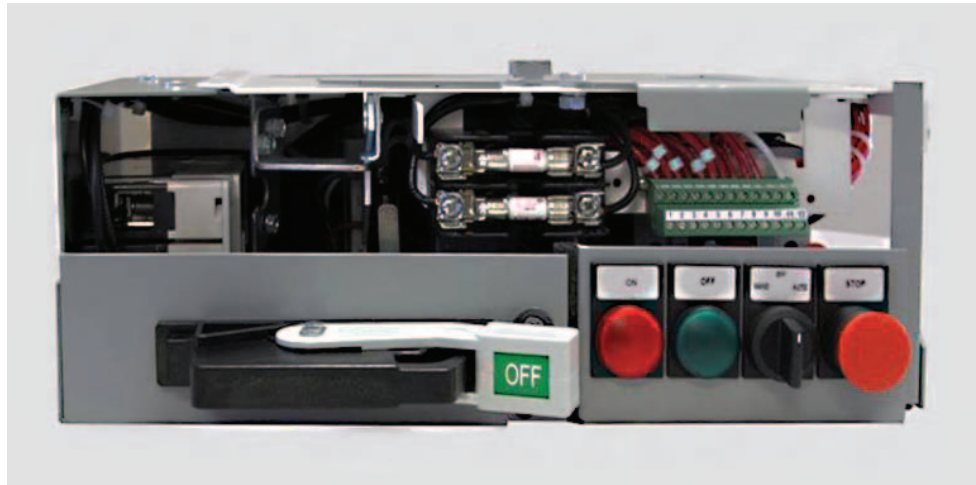

Compact High Density (HD) Combination Starters

While meeting UL and NEMA standards, our Compact Modular High Density Units reduce unit size by 6" (up to 50%) for starters sizes 1-4; thus, reducing footprint and saving floor space. In the Compact High Density units, only ESP200 overload relays are available. 22mm pilot devices are available with a maximum of four pilot devices per unit.

Full Voltage Non-Reversing (FVNR) Unit with Circuit Breaker

NEMA Size	Maximum Horsepower Rating			Circuit Breaker Type			
	208V	230V	480V	Standard Breaker Type	MCP Frame Size (Amps)	Unit Height Dimensions in inches (mm)	kA Interrupting Rating at 480V ¹
1	7.5	7.5	10	MCP	125	6 (152)	100
2	10	15	25			12 (305)	
3	25	30	50		125/250	18 (457)	
4	40	50	100				

Full Voltage Contactor (FVC) Unit with Circuit Breaker

NEMA Size	Maximum KW Resistance Heating Loads			Circuit Breaker Type	
	208V	230V	480V	Unit Height Dimensions in inches (mm)	kA Interrupting Rating at 480V ¹
1	9.7	10.7	22	6 (152)	100
2	16.2	17.9	37		
3	32	35.8	74	12 (305)	
4	48	54	112	18 (457)	

¹ For other available voltage ratings contact Siemens



Reduced Voltage Soft-Starter (RVSS) Units

Siemens soft-start controllers and starters incorporate the latest in solid-state technology to provide precise control in the starting of AC induction motors. Solid state reduced voltage starting allows motor voltage to be gradually applied, reducing potentially damaging high inrush currents and starting torques. These controls are easy to set up, operate, troubleshoot and repair. They are fully adjustable for many applications and with voltage ramp capability, can handle varying loads. Soft-start controllers can lower operating costs by reducing downtime due to equipment maintenance and repair; and minimize product and drive system damage caused by hard physical starts or stops. Siemens Soft-Start controllers with the energy saving feature conserve energy during lightly loaded conditions by reducing the motor voltage and current

Overview

The advantages of the SIRIUS soft starters at a glance:

- Soft starting and soft stop
- Stepless starting
- Reduction of current peaks
- Avoidance of mains voltage fluctuations during starting
- Reduced load on the power supply network
- Reduction of the mechanical load in the operating mechanism
- Considerable space savings and reduced wiring compared with mechanical reduced voltage starters
- Maintenance-free switching
- Fits perfectly in the SIRIUS modular System

SIRIUS 3RW40

SIRIUS 3RW40 soft starters include soft start and soft stop, and internal bypass. At the same time they come with additional functions, i.e. selectable solid-state motor overload, intrinsic device protection and adjustable current limiting, as well as a new patented two-phase control method (Polarity Balancing) that is unique in this rating range.

SIRIUS 3RW40 soft starters are part of the SIRIUS modular system. This results in advantages such as identical sizes and a uniform connection system. Thanks to their particularly compact design, SIRIUS 3RW40 soft starters are only half as big as comparable wye-delta starters. Hence they can be mounted in compact space requirements in the control cabinet. Configuring and installation are carried out quickly and easily thanks to the 3-wire connection.

SIRIUS 3RW40 for three-phase motors Soft starters rated up to 300 Hp (at 460 V) for standard applications in three phase power systems. Extremely small sizes, low power losses and simple commissioning are just three of the many advantages of the SIRIUS 3RW40 soft starters.



Application areas:

- Fans
- Pumps
- Building/construction machines
- Presses
- Escalators
- Transport systems
- Air conditioning systems
- Ventilators
- Assembly lines
- Operating mechanisms

SIRIUS 3RW44

In addition to soft starting and soft stopping, the solid-state SIRIUS 3RW44 soft starters provide numerous functions for higher-level requirements. They cover a rating range up to 800HP at 460 V in the inline circuit. The SIRIUS 3RW44 soft starters are characterized by a compact design for space-saving and clearly arranged control cabinet layouts. For optimized motor starting and stopping, the innovative SIRIUS 3RW44 soft starters are an attractive alternative with considerable savings potential compared to applications with a frequency converter.

The new torque control and adjustable current limiting enable these high feature soft starters to be used in nearly every conceivable task. They reliably mitigate the sudden torque applications and current peaks during motor starting and stopping. This creates savings potential when calculating the size of the control gear and when servicing the machinery installed.

Be it for inline circuits or inside delta circuits – the SIRIUS 3RW44 soft starter offers savings especially in terms of size and equipment costs. Combinations of various starting, operating and ramp-down possibilities ensure an optimum adaptation to the application specific requirements. Operating and commissioning can be performed by means of the user-friendly keypad and a menu prompted, multi-line graphic display with background lighting. The optimized motor ramp-up and ramp down can be effected by means of just a few settings with a previously selected language. Four-key operation and plain-text displays for each menu point guarantee full clarity at every moment of the parameterization and operation.



Application areas

- Pumps
- Mills
- Ventilators
- Saws
- Compressors
- Crushers
- Water transport
- Mixers
- Conveying systems and lifts
- Centrifuges
- Hydraulics
- Industrial cooling and refrigerating systems

MCC Enclosures

480V¹ Solid State Reduced Voltage — NEMA 1 MCC Enclosures²



Rating HP ³	RVSS Type ⁶		Rated Amperes	Dimensions - In. (mm) ^{4,5}		kA Interrupting Rating	
				Mounting Height	Structure W x D		
5	3RW40		9	18 (457)	20 x 15 (508 x 381)	100	
10	3RW40		19				
15	3RW40		24				
20	3RW40		28				
25	3RW40		34				
30	3RW40		42				
40	3RW40		58	24 (610)			
50	3RW40		70				
75	3RW40		117	36 (914)			
100	3RW40		145				
150	3RW40		205	48 (1219) ⁷			
200	3RW40		315				
300	3RW40		385	72 (1829) ⁷			
15		3RW44	26	36 (914)	20 x 15 (508 x 381)	100	
20		3RW44	32				
25		3RW44	42				
30		3RW44	52				
40		3RW44	68				
50		3RW44	82				
60		3RW44	100				
75		3RW44	117				
100		3RW44	145				
125		3RW44	180				
150		3RW44	215				48 (1219) ⁷
250		3RW44	385				72 (1829) ⁷
400		3RW44	494				
450		3RW44	562				
500		3RW44	693				
600		3RW44	850				
750		3RW44	970	Consult Siemens			
800		3RW44	1076	Consult Siemens	42		

1 For other available voltage ratings, consult Siemens.
 2 For other enclosure types, consult Siemens.
 3 Ratings are based on CLASS 20 overloads and 6 starts per Hour. Consult Siemens for other applications.
 4 Dimensions shown are for circuit breaker or fusible disconnects.
 5 RVSS with bypass and / or isolation contactors require extra mounting space. Consult Siemens for further information.
 6 3RW40 Units include line side isolation contactor
 7 Fixed mounted units (not plug-in).



Variable Frequency Drive (VFD) Units

Micromaster 440 (MM440)

Application





The MICROMASTER 440 inverter is suitable for a variety of variable-speed drive applications. Its flexibility provides for a wide spectrum of applications. These also include cranes and hoisting gear, high-bay warehouses, production machines for food, beverages and tobacco, packaging machines etc.; i.e. applications which require the frequency inverter to have a higher functionality and dynamic response than usual. The inverter is especially characterized by its customer-oriented performance and ease of-use. Its large voltage range enables it to be used all over the world.

Micromaster 440 (MM440)

Design

The MICROMASTER 440 inverter has a modular design. The operator panels and modules can be easily exchanged.

International standards

- The MICROMASTER 440 inverter complies with the requirements of the EU low voltage directive.
- The MICROMASTER 440 inverter has the  marking
- acc. to  and c  certified
- c-tick 

Main characteristics

- Easy, guided start-up
- Modular construction allows maximum configuration flexibility
- Six programmable isolated digital inputs
- Two scalable analog inputs (0 V to 10 V, 0 mA to 20 mA)
can also be used as a 7th/8th digital input
- Two programmable analog outputs (0 mA to 20 mA)
- Three programmable relay outputs (30 V DC/5 A resistive load;
250 V AC/2A inductive load)
- Low-noise motor operation thanks to high pulse frequencies,
adjustable (observe derating if necessary)
- Complete protection for motor and inverter.

Options (overview)

- EMC filter, Class A/B
- LC filter and sinusoidal filter
- Line commutating chokes
- Output chokes
- Gland plates
- Basic Operator Panel (BOP) for parameterizing the inverter
- Plain text Advanced Operator Panel (AOP) with multi-language display
- Communication modules
 - PROFIBUS
 - DeviceNet
 - CANopen
- Pulse encoder evaluation module
- PC connection kits
- Mounting kits for installing the operator panels in the control cabinet doors
- PC start-up tools executable under Windows 98 and NT/2000/ME/XP Professional
- TIA integration with Drive ES

Micromaster 440 (MM440)

MCC Enclosures

480V¹ Variable Frequency Drives — NEMA 1A MCC Enclosures²

Rating HP ³	Drive Type	Rated Amperes	Dimensions - in. (mm) ^{4, 6}		kA Interrupting Rating at 480V
			Mounting Height	Structure W x D	
2	MM440	4	18 (457)	20 x 15 (508 x 381)	25-65 (standard) / 100 (standard fusible, optional circuit breaker)
5		10.2	24 (610)		
7.5		16			
10		18.4	36 (914)		
15		26			
20		32			
25		38	48 (1219) ⁷		
30		45	48 (1219) ^{5,7}		
40		62			
50		76	60 (1624) ⁷		
60		90			
75		110	72 (1829) ⁷	20 x 15 ⁵ (508 x 381)	
100		145			
125		178			
150		205		30 x 15 ⁵ (762 x 381)	
200		250			

1 For other available voltage rating, consult Siemens

2 For other enclosure types, consult Siemens

3 Ratings are for Variable Torque applications. Consult Siemens for other applications

4 Dimensions shown are for circuit breaker or fusible disconnects except as noted

5 Fusible disconnect unit is larger, consult Siemens

6 Drives with bypass and/or isolation contactors require extra mounting space.

Consult Siemens for further information.

7 Fixed mounted units (not plug-in)

600V Variable Frequency Drives — NEMA 1A MCC Enclosures¹

Rating HP ³	Drive Type	Rated Amperes	Dimensions - in. (mm) ^{3, 5}		kA Interrupting Rating at 480V
			Mounting Height	Structure W x D	
2	MM440	2.7	24 (610)	20 x 15 (508 x 381)	18-22 (standard) / 100 (standard fusible, optional circuit breaker)
5		6.1			
7.5		9			
10		11			
15		17			
20		22			
25		27	48 (1219) ⁶	20 x 15 ⁴	
30		32			
40		41			
50		52	60 (1624) ⁶	20 x 15 ⁴	
60		62			
75		77	72 (1829) ⁶	20 x 15 ⁴	
100		99			
125		125			

1 For other enclosure types, consult Siemens

2 Ratings are for Variable Torque applications. Consult Siemens for other applications

3 Dimensions shown are for circuit breaker or fusible disconnects except as noted

4 Fusible disconnect unit is larger, consult Siemens

5 Drives with bypass and/or isolation contactors require extra mounting space.

Consult Siemens for further information.

6 Fixed mounted units (not plug-in)

Micromaster Drives

Technical Data

MM440 - Technical Data	
Voltage and power ranges	200–240 V, $\pm 10\%$, 0.166 to 60 HP (CT / VT) 380–480 V, $\pm 10\%$, 0.5 to 150 HP (CT) 380–480 V, $\pm 10\%$, 0.5 to 200 HP (VT) 500–600 V, $\pm 10\%$, 1.0 to 100 HP (CT) 500–600 V, $\pm 10\%$, 1.0 to 125 HP (CT)
Operating temperature	0 °C to +40 °C
Process control	Internal PID controller (autotuning)
Types of control	Vector control, FCC (Flux Current Control), multipoint characteristic (parameterizable V/f characteristic), V/f characteristic

MM420 - Technical Data	
Voltage and power ranges	200-240 V, $\pm 10\%$, 0.16 to 7.5 HP 380-480 V, $\pm 10\%$, 0.5 to 15 HP
Operating temperature	–10 °C to +50 °C
Process control	PID process controller
Types of control	V / Hz, Voltage Boost, Slip Compensation, FCC (Flux Current Control)
Inputs	3 digital inputs, 1 analog input
Outputs	1 analog output, 1 relay output

MM430 - Technical Data	
Voltage and power ranges	380-480 V, $\pm 10\%$, 10 to 125 HP
Operating temperature	0 °C to +40 °C
Process control	PID process controller
Types of control	V / Hz, Voltage Boost, Slip Compensation, FCC (Flux Current Control)
Inputs	6 digital inputs, 2 analog inputs, 1 PTC/KTY input
Outputs	2 analog outputs, 3 relay outputs

Factory Options

Contactor Options

Bypass Contactor (None/Automatic/Manual/Selectable)

Input Isolation Contactor

Output Isolation Contactor

VFD Options

Operator Panel (Basic/Advanced/None)

Door Mounted Operator Panel (None/Single VFD/ Advanced Operator Panel (AOP)

Communication Module (PROFIBUS, DeviceNet, CANopen, LON, etc.)

Pulse Encoder Module

PC to VFD connection kit

Reactor, Filter, and Other Options

Input/Output Reactor

Passive harmonic filter

RFI filter

Output filter (DV/DT, sine wave)

Pulse Resistor Braking¹

Semiconductor Fuses

¹ Recommend that resistor banks should be installed outside of the MCC. Consult factory for further details.

Pollution Degree Ratings according to UL61800-5-1

MCCs containing VFDs should be installed in a Pollution Degree 2 environment in accordance with UL61800-5-1. If an MCC with VFD is to be placed in a Pollution Degree 3 or higher environment, a NEMA12 rated MCC should be installed.

Pollution Degree	Description
1	No pollution or only dry, non-conductive pollution occurs. The pollution has no influence.
2	Normally, only non-conductive pollution occurs. Occasionally, however, a temporary conductivity caused by condensation is to be expected, when the VFD is out of operation.
3	Conductive pollution or dry non-conductive pollution occurs, which becomes conductive due to condensation, which is to be expected.
4	The pollution generates persistent conductivity caused, for example by conductive dust or rain or snow.



SINAMICS G120C

SINAMICS G120C has been especially designed for an economic, space-saving and easy-to-operate frequency converter providing a multitude of functions. This device combines in particular compactness with superior power density and is characterized by fast installation and commissioning.

Smallest size

- Compact design (integrated braking chopper)
- Fast mechanical installation (i.e. pluggable terminals)

Easy to use

- Simple, optimized commissioning with the STARTER tool
- Effective, adequate parameter set (simple storing and cloning functions using IOP, BOP-2 or SD card)
- Usable with IOP or BOP-2 operator panels

Leading edge technology

- Energy-efficient, encoder-less vector control - automatic flow reduction with V/F ECO
- Safety Integrated (Safe Torque Off)
- Communication PROFIBUS DP, PROFINET, CAN and USS/ Modbus RTU

Application

For industrial and commercial applications (secondary drive in production machines or generally for water/waste water, automotive). Application examples include mixers, extruders, simple pumps, fans, compressors, vibrator motors, simple wire drawing machines.

SINAMICS G120C

Design

SINAMICS G120C is a compact inverter where the Control Unit (CU) and Power Module (PM) function units are combined in one device. SINAMICS G120C can be integrated into the widest range of applications, either using the integrated digital and analog inputs or via the integrated fieldbus interface (available in the USS/ Modbus RTU, PROFINET, PROFIBUS DP, CANopen versions). Especially the product versions with integrated PROFIBUS DP or Profinet interface make full integration into the Siemens TIA family possible, therefore allowing the advantages of the seamless TIA product family to be fully utilized. SINAMICS G120C devices are preset in the factory so that they can be immediately connected to PROFIBUS DP or Profinet fieldbuses and used without parameterization.

G120C- Technical Data

Frame Size	Output Ratings				Dimensions - in. (mm) ¹		IR
	LO-OL	LO-OL	HI-OL	HI-OL	Mounting Height	Structure W x D	
	A	hp	A	hp			
A	1.4	0.5	1.1	0.5	18 (457)	20 x 15 (508 x 381)	65ka
A	1.9	0.75	1.4	0.5			
A	2.6	1	1.9	0.75			
A	3.5	2	2.6	1			
A	4.8	2	3.5	2			
A	6.2	3	4.8	2			
A	7.5	3	6.2	3			
B	10.6	5	7.5	3	24 (610)		
B	14.0	10	10.6	5			
C	21.3	15	14.0	10	30 (762)		
C	26.4	15	21.3	15			
C	31.5	20	26.4	15			

¹ Circuit Breaker, Reactor (Line or Load) and Drive Included.

Overload capability:

- **High overload (HO):**
200% base load current I_H for 3 s plus
150% base load current I_H for 57 s within a 300 s cycle time
- **Light overload (LO):**
150% base load current I_H for 3 s plus
110% base load current I_H for 57 s within a 300 s cycle time

SINAMICS G120C

Factory Options

Technical Data	
Voltage and power ranges	380–480 V, 0.5 to 20 HP (LO) 380–480 V, 0.5 to 15 HP (HO)
Operating temperature	0 °C to +40 °C
Process control	Internal PID controller (auto-tuning)
Types of control	Vector control, FCC (Flux Current Control), multipoint characteristic (parameterizable V/f characteristic), V/f characteristic
Communications	PROFIBUS DP, PROFINET, CANopen and USS/ Modbus RTU

For additional G120C information, please see the SINAMICS and Motors for Single-Axis Drives Catalog, Order No. E86060-K5531-A101-A1-7600.

Contactor Options
Bypass Contactor (None/Automatic/Manual/Selectable)
Input Isolation Contactor
Output Isolation Contactor

VFD Options
Operator Panel (BOP-2, IOP, none)
Door Mounted Operator Panel
PC Inverter Connection Kit 2

Reactor, Filter, and Other Options
Input/Output Reactor
Passive harmonic filter
RFI filter
Output filter (DV/DT, sine wave)
Pulse Resistor Braking ¹
Semiconductor Fuses

¹ Recommend that resistor banks should be installed outside of the MCC. Consult factory for further details.



SINAMICS G120

SINAMICS G120 is a modular drive inverter system that comprises various function units. These are essentially: Control Unit (CU) and Power Module (PM). The CU controls and monitors the PM and the connected motor in several operating modes that can be selected. It supports communication with a local or central controller and monitoring devices.

- **With many innovative functions**

Safety Integrated for safety-relevant machines and systems, capable of regenerative feedback into the line supply for energy saving

- **Fast commissioning**

STARTER tool and data backup using the BOP-2, IOP or MMC/SD card

- **Efficient and consistent solutions**

via Totally Integrated Automation (TIA), consistency from SINAMICS through to the automation level

Application

Machines and plants in industrial and commercial applications (machinery construction, automotive, textiles, chemical industry, printing, steel). Application examples include: Pumps and fans, Compressors, Centrifuges, Conveyor systems.

Design

Application-oriented design of SINAMICS G120

SINAMICS G120 standard inverters are modular inverters for standard drives. Selection of the SINAMICS G120 is reduced to two or three steps thanks to the modular system used.

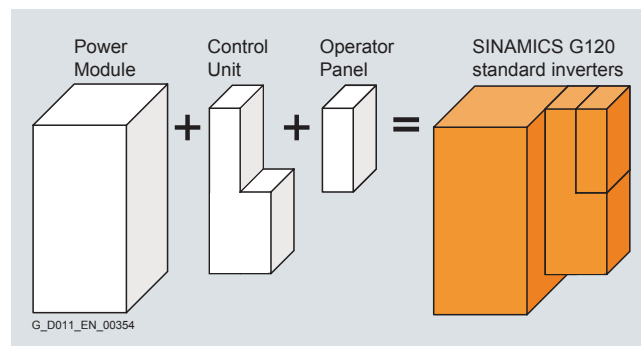

Selecting the Power Module

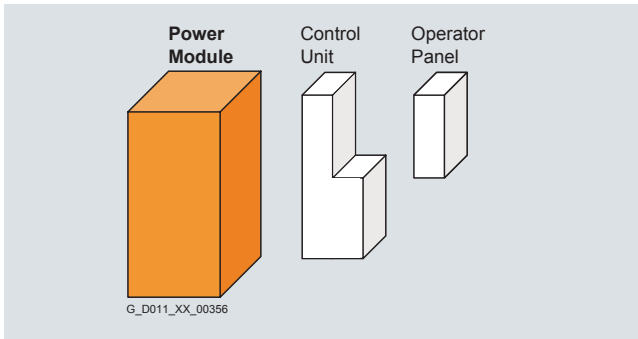

PM240 Power Modules

PM240 Power Modules are suitable for many applications. The PM240 has an integrated braking chopper in frame sizes FSA up to FSF and has the possibility of connecting a braking resistor. For frame size FSGX, an optional pluggable braking module can be ordered.



PM250 Power Modules

PM250 power modules are suitable for the same applications as the PM240, but they are specialized to address conveyor-related applications - where the braking energy is directly fed back into the line supply using the unique technology of Efficient Infeed Technology. This feature provides the ability to feed energy back into the supply system in the generator mode (electronic braking) so that the energy is not wasted in a braking resistor.



SINAMICS G120

Selecting the Control Unit

The optimum Control Unit is selected, based on the number of I/Os and any additional functions required such as Safety Integrated or HVAC. The communication options are already integrated and do not have to be additionally ordered or plugged in. Three product series are available corresponding to the particular application.

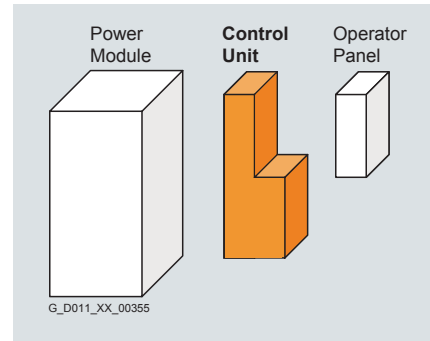

MCC Control Unit Options

CU230P-2 HVAC	CU240B-2	CU240E-2	CU250S-2
CU230P-2 DP	CU240B-2 DP	CU240E-2 DP	CU250S-2 DP
CU230P-2 CAN		CU240E-2 F	CU250S-2 PN
CU230P-2 PN		CU240E-2 DP-F	CU250S-2 CAN
		CU240E-2 PN	
		CU240E-2 PN-F	



- Extended I/O configuration
- Vector and servo control
- Encoder feedback
- Basic and Extended Safety Functions
- USS, Modbus, PROFIBUS, PROFINET



- Basic I/O configuration
- USS, Modbus, PROFIBUS, PROFINET



- Standard I/O configuration
- STO as standard
- Optional Basic Safety Functions
- USS, Modbus, PROFIBUS, PROFINET



- Extended I/O configuration
- Vector and servo control
- Encoder feedback
- Basic and Extended Safety Functions
- USS, Modbus, PROFIBUS, PROFINET

Selecting the Control Unit (cont.)

CU230 Control Units

The CU230 Control Units have been specifically designed for pump, fan and compressor applications.

CU240 Control Units

The CU240 Control Units are suitable for a wide range of applications in a general machine construction, such as conveyor belts, mixers and extruders.

CU250 Control Units

The CU250 Control Unit is particularly suited for drives with high requirements in speed and torque accuracy.

Selecting Optional System Components

Intelligent Operator Panel IOP

Graphic display with bar-type diagrams, e.g. for status values such as pressure or flow rate.

Basic Operator Panel BOP-2

Menu navigation and 2-line display permit fast and user-friendly commissioning of the inverter. Simple basic commissioning by simultaneously displaying parameter value, as well as the option of filtering parameters.

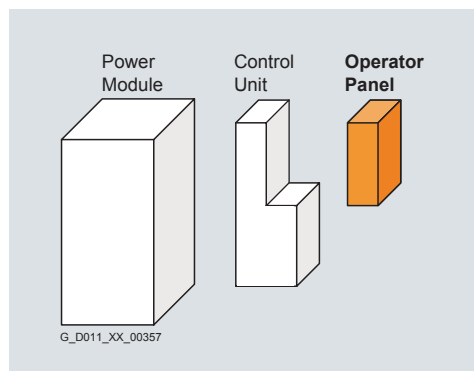

SINAMICS G120

Technical Data

	Frame Size	Output Ratings				Dimensions - in. (mm) ¹		IR
		LO-OL	LO-OL	HI-OL	HI-OL	Mounting Height	Structure W x D	
		A	hp	A	hp			
PM240	A	1.2	0.5	1.3	0.5	18 (457)	20 x 15 (508 x 381)	65ka
	A	1.6	0.5	1.7	0.75			
	A	2.0	0.75	2.2	1			
	A	2.9	1	3.1	1.5			
	A	3.8	2	4.1	2			
	B	5.5	3	5.9	3	24 (610)		
	B	7.2	3	7.7	5			
	B	9.5	5	10.2	5			
	C	16.7	10	13.2	7.5	36 (914)		
	C	23.3	15	19	10			
	C	29.8	20	26	15			
	D	35.3	25	32	20	48 (1219)	20 x 15 ² (508 x 381)	
	D	41.9	30	38	25			
	D	55.8	40	45	30			
	E	69.8	50	60	40	60 (1624)		
	E	83.7	60	75	50			
	F	102.3	75	90	60	72 (1829)		
	F	134.9	100	110	75			
F	165.5	125	145	100				
F	190.7	150	178	125				
F	240.0	150	200	150				
Gx	264.3	200	250	200	40 x 20 ² (1016 x 508)			
Gx	323.8	250	302	250				
Gx	417.4	350	370	300				
PM250	D	35.3	25	32	20		48 (1219)	20 x 15 ² (508 x 381)
	D	41.9	30	38	25			
	D	55.8	40	45	30			
	E	69.8	50	60	40	60 (1624)		
	E	83.7	60	75	50			
	F	102.3	75	90	60	72 (1829)	20 x 20 ² (508 x 508)	
F	134.9	100	110	75				
F	165.5	125	145	100				

1 Circuit Breaker, Reactor (Line or Load) and Drive Included.

2 Fixed Mounted

Overload capability:

• High overload (HO):

Up to 100 HP PM240 and all PM250 (HO): 2 × base-load current I_H (i. e. 200 % overload) for 3 s
plus 1.5 × base-load current I_H (i. e. 150 % overload) for 57 s within a cycle time of 300 s
 From 125 HP PM240: 1.6 × base-load current I_H (i. e. 160 % overload) for 3 s
plus 1.36 × base-load current I_H (i. e. 136 % overload) for 57 s within a cycle time of 300 s

• Light overload (LO):

Up to 100 HP PM240 and all PM250 (LO): 1.5 × base-load current I_L (i. e. 150 % overload) for 3 s
plus 1.1 × base-load current I_L (i. e. 110 % overload) for 57 s within a cycle time of 300 s
 From 125 HP PM240: 1.5 × base-load current I_L (i. e. 150 % overload) for 1 s
plus 1.1 × base-load current I_L (i. e. 110 % overload) for 59 s within a cycle time of 300 s

Technical Data

Voltage and power ranges	380–480 V, 0.5 to 350 HP (LO) 380–480 V, 0.5 to 300 HP (HO)
Operating temperature	0 °C to +40 °C
Process control	Internal PID controller (autotuning)
Types of control	Vector control, FCC (Flux Current Control), multipoint characteristic (parameterizable V/f characteristic), V/f characteristic

Factory Options

Contactors Options

Bypass Contactor (None/Automatic/Manual/Selectable)

Input Isolation Contactor

Output Isolation Contactor

VFD Options

Operator Panel (BOP-2, IOP, none)

Door Mounted Operator Panel

PC Inverter Connection Kit 2

Reactor, Filter, and Other Options

Input/Output Reactor

Pulse Resistor Braking²

Passive harmonic filter¹

Semiconductor Fuses

RFI filter

18-pulse (for FSE and FSF)

Output filter (DV/DT, Sinewave)

¹ Not recommended for applications that use generated power, such as water/waste-water market.

² Recommend that resistor banks should be installed outside of the MCC. Consult factory for further details.

For additional G120 information, please see the SINAMICS and Motors for Single-Axis Drives Catalog, Order No. E86060-K5531-A101-A1-7600.

Pollution Degree Ratings according to UL61800-5-1

MCCs containing VFDs should be installed in a Pollution Degree 2 environment in accordance with UL61800-5-1. If an MCC with VFD is to be placed in a Pollution Degree 3 or higher environment, a NEMA12 rated MCC should be installed.

Pollution Degree	Description
1	No pollution or only dry, non-conductive pollution occurs. The pollution has no influence.
2	Normally, only non-conductive pollution occurs. Occasionally, however, a temporary conductivity caused by condensation is to be expected, when the VFD is out of operation.
3	Conductive pollution or dry non-conductive pollution occurs, which becomes conductive due to condensation, which is to be expected.
4	The pollution generates persistent conductivity caused, for example by conductive dust or rain or snow.

Unit Options

Overload Options

Overload Protection	Description
Thermal Bimetal Ambient Compensated Single Phase and Three Phase	Class 10 or Class 20 Protection +/- 15% Setting of nominal trip current
ESP200 Solid State Overload Relay	Trip Class 5, 10, 20, or 30 can easily be set by two DIP switches Eliminates the need for heaters
SIMOCODE	Solid State Overload Protection Class 5 - 40 Multifunctional, electronic full motor protection Detailed operating, service, and diagnostics data via PROFIBUS

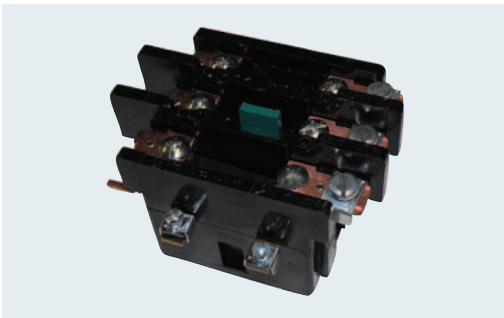

Thermal Bimetal Ambient Compensated Overload

Bimetal ambient compensated overload relays protect both the motor and equipment by opening the control circuit when the motor experiences an overload condition. The bimetal overload relay may be set for either manual or automatic reset and can be supplied with standard Class 20 heater elements or optional Class 10 heater elements as required.



ESP200 Solid State Overload Relay

Building and improving on past successes, self-powered ESP200 overload relays are a revolution for both industrial and construction applications. These overload relays provide accuracy unmatched in the market. With repeat accuracy of greater than 99%, trips can be set to the most specific conditions, resulting in both longer motor life and cost savings. The ESP200 over-load relay is very simple to configure. Just set the FLA dial to match the FLA of the motor nameplate and set the DIP switches per the faceplate engraving.

SIMOCODE

Smart MCC uses SIMOCODE in the units to give the customer a true motor management system. SIMOCODE pro is the flexible and modular motor control system for low-voltage motors. It can easily and directly be connected to automation systems via PROFIBUS and covers all functional requirements between the motor starter and the automation system – including the fail-safe disconnection of motors. Further, SIMOCODE pro combines in just one compact system all required protection, monitoring, safety and control functions. The motor management system thus helps you to increase the process control quality and reduce costs at the same time – from planning through installation right to operation or service of a plant or system. In the MCCs, SIMOCODE pro C and SIMOCODE pro V are available.

Benefits from SIMOCODE pro:

- Simple configuration
- Protects your flexibility with the aid of optional expansion modules
- Gain transparency throughout your system with extensive data provision

SIMOCODE pro motor management is structured in functionally graded series:

- SIMOCODE pro C, as a compact system for direct-on-line starters and reversing starters or the actuation of a circuit breaker with PROFIBUS-interface
- SIMOCODE pro V, as a variable system with all control functions and with the possibility of expanding the inputs, outputs and other functions of the system using expansion modules.



SIMOCODE pro C



SIMOCODE pro V

SIMOCODE Expansion

Expansion Possibilities	SIMOCODE pro C (Basic Unit 1)	SIMOCODE pro V PB (Basic Unit 2) ¹
Operator panels	X	X
Operator panel with display	—	X
Current measuring modules	X	X
Current/voltage measuring module (Qty)	—	X
Decoupling module (Quantity)	—	X
Expansion modules (number):		
Digital modules	—	2
Fall Safe digital module ²	—	1
Analog module	—	1
Ground fault module	—	1
Temperature module	—	1

X= available, - = not available

1 When an operator panel with display and/or decoupling module is used, restrictions on the number of connection modules connectable per basic unit must be observed.

2 The fall-safe digital module can be used instead of one of the two digital modules.

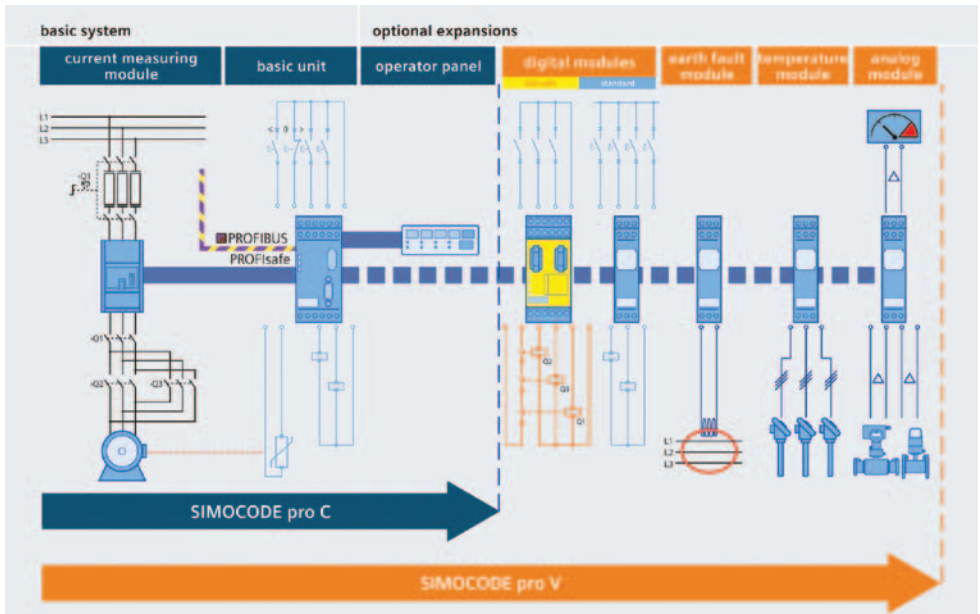
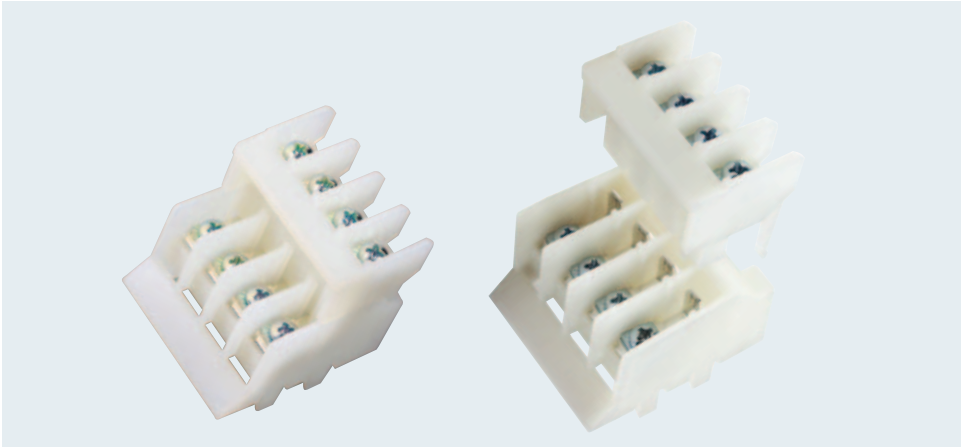

Figure 53. SIMOCODE System



Terminal Blocks

Control Terminal Blocks

Rail mounted pull-apart control terminals are standard for both type B and C units. All terminal blocks are located at the right front of the unit for access from the vertical wireway.

Unit control terminal blocks are:

- White in color
- Box Type with Tang (wire clamped between tang and collar)
- Supplied with White Marking Strip

Terminals supplied in groups of 4 for Pull-Apart terminal blocks or groups of 3 for Stationary terminal blocks as required for application. Standard terminal block mounting allows for a maximum of 21 Stationary or 20 Pull-Apart terminal points for control.

Type	Wire Range	Amp Rating	Voltage
Pull-Apart	16 - 12 ga.	25A	600V
Stationary	22 - 8 ga.	40A	600V

Pull-Apart Terminal Blocks

Pull-Apart terminal blocks pull apart and interlock mechanically, providing a terminal block assembly in which individual groups are free to move to permit electrical separation while remaining coupled mechanically to the series.

Clamping the wire between a tang and a collar provides the following advantages:

- No twisted off strands.
- A constant locking torque keeps screws in position.
- Hardened stainless steel clamping collar eliminates stripped thread problems.
- Terminal blocks are also available with screw type terminals for ring tongue lugs.

Stationary Terminal Blocks

Stationary terminal blocks are available. They have the same features as Pull-Apart, except they remain fixed and do not separate.

Load Terminal Wire Ranges

Starter Size	Wire Range Starter Load Terminal	Maximum ¹ AWG	Type Bd, Bt, & C Wiring		Optional Pull-Apart
			Power Terminal Block Wire Range	Stationary	
0-1	#14 to #8	#8	#22 to #8	X	X
2	#12 to #2	#6	#18 to #2	X	X
3	#8 to #2/0	#1	#14 to #2/0	X	—
4	#6 to 250kcmil	2/0	—	—	—
5	(1) #4 to 600kcmil (2) #1/0 to (2) 250kcmil	— 350kcmil	— —	— —	— —
6	#2 to (2) 600kcmil (1) 600kcmil	(2) 350 kcmil —	— —	— —	— —

¹ To maintain proper bending space for load cables direct to the starter do not exceed max. wire gauge listed.

Type C Wiring Terminal Blocks

Type C wiring uses stationary type terminal blocks. Their standard location is in the top 12" horizontal wireway.

C terminals may also be located in the bottom 6" horizontal wireway. Three rows of terminals for control and load may be mounted at the top. Space is available for 42 terminals per row for control and load. For each unit size 2, reduce 3 terminals per unit, due to larger load blocks. For each unit size 3, reduce 6 per unit. The bottom wireway is limited to one row of terminals only. C terminals cannot be located in the same area as incoming lines. C terminals for a section with incoming lines, whether connected to main lugs or main disconnect, will be located in an adjacent section. C terminals will be restricted to two rows in a section with a print pocket. Ground or neutral bus should not be located in the same area as C terminals because of restricted conduit room and the number of C terminals that can be mounted.

Master Terminal Block Location

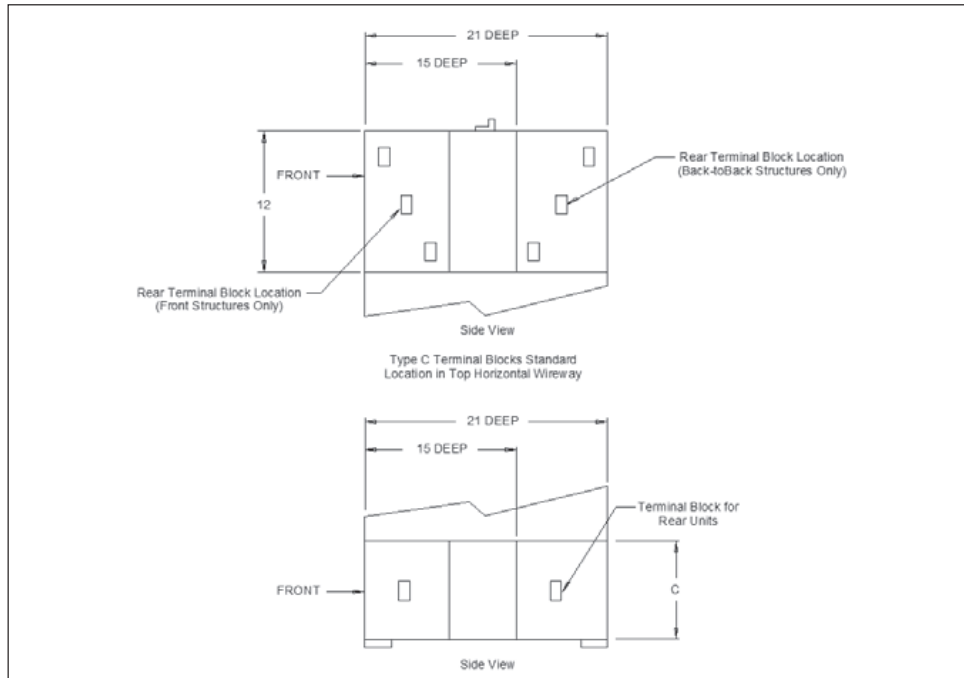

Figure 54. Master Terminal Block Location Dimensions

Terminal Blocks

Load Terminal Blocks

If NEMA Type B-t wiring option is specified, load terminal blocks are supplied on units through Size 3 starters. Pull-apart load terminal blocks can be provided through Size 2. Size 3 starters will be supplied with stationary (non pull-apart) load terminal blocks. Load terminals are white in color.

Wiring Specifications

Control on Units	16 ga. copper	
	105°C	
	600V	
Interconnection control wiring between Units	14 ga. copper	
	105°C	
	600V	
Power wiring– Sized to suit maximum HP rating of unit	14 ga. to 2 ga. copper	105°C
		600V
	1 ga. to 500 kcmil copper	105°C
		600V

Standard Color Coding of Wires

AC Control (all voltages)	Red
DC Control (all voltages)	Blue
AC Power(all voltages)	Black
Line Side CPT	Black
Equipment Ground	Green
Current Carrying Neutral	White
Interconnecting Control Wires Between Units	Red

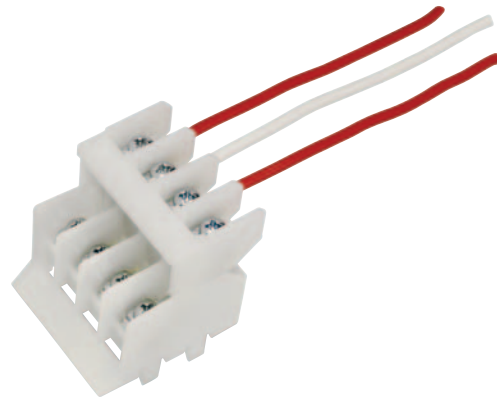

Pilot Devices



**22mm
Standard**

SIRIUS 3S

Plastic

LED

NEMA Type 4



**30mm
Optional**

Class 52

Oil Tight

Transformer Type or LED

NEMA Type 3, 4, 12 and 13

Pilot Device Options

Option	Description	FVNR	FVC	FVR	2S1W 2S2W
Push Buttons	Start - Stop	X	X		
	Forward - Reverse - Stop			X	
	Fast - Slow - Stop				X
	High - Low - Stop				X
Selector Switch	Hand - Off - Auto	X	X	X	X
	Off - On	X	X		
	Start - Stop	X	X		
	Forward - Off - Reverse			X	
	Slow - Off - Fast				X
	High - Off - Low				X
Pilot Device Housing	Blank	X	X	X	X
	4 Holes	X	X	X	X

Pilot Lights Options

Description	FVNR	FVC	FVR	2S1W / 2S2W
Running	X	X		
Off	X	X	X	
Running - Off	X	X		
On - Off	X	X		
Forward - Reverse			X	
Forward - Reverse - Off			X	
High - Low				X
High - Low - Off				X

Standard Control Transformer Sizes in VA²

Starter Size	FVNR / FVR	RVAT	Wye Delta	2S1W	2S2W
0	50	—	—	50	50
1	50	150	150	50	50
2	50	150	150	150	50
3	150	150	150	150	150
4	150	50 ¹	50 ¹	50 ¹	150
5 ¹	50	50	50	50	50
6 ¹	50	50	50	50	50

¹ Starter supplied with interposing relay(s).

² The CPT sizes will allow for the use of a pilot light.

Excess Capacity CPT VA Rating FVNR Starter Standard Size VA Rating

Starter Size	FVNR Standard VA Rating	Excess Capacity Above Starter Required	VA Rating Required for 100 VA Extra	Inrush Requirement VA	Inrush Capacity of Standard Transformer
0	50	25	150	218	218
1	50	25	150	218	218
2	50	24	150	218	218
3	150	124	250	310	1130
4	150	99	250	510	1130
5 ¹	50	25	150	27	218
6 ¹	50	25	150	27	218

¹ Starter supplied with interposing relay(s).

Fuse Selection - Control Power Transformer

Transformer VA	Secondary Fuse Size			Primary Fuse Size		
	24V	120V	240V	240V	480V	600V
50	3.2	0.6	0.3	1	0.5	0.3
150	10	2	1	3	1.5	1
250	12	3.2	1.6	5	2.5	2

Handle Auxiliary Switch

A handle auxiliary switch is available on the disconnect operating handle for breakers and fusible switches. The standard switch has Form C contact, which is normally used to disconnect separate source voltage in the unit.



Standard Options	
Amp meter + CT	EIapse time meter
CT	Surge supression
Voltage monitor	Under voltage CB
Vac. contactor	Shunt Trip
Transducer	Ground stab
Fuse Puller	Special paint
Bypass	Timer
ASI®	4P relay
Ground fault	Extra unit space

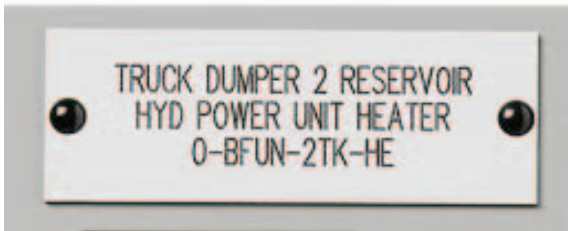

Nameplate

Nameplates for individual units are 1.25" tall by 3.56" wide and can have three (standard) or four engraving lines. Unit nameplates are fastened to the unit door with plastic rivets. Stainless screw mounted unit nameplates are available as an option. The standard color for unit nameplates is a black surface with a white text. Other unit nameplate colors, such as a white surface with a black text or dark gray surface with white text or light gray with black text or red with white text or yellow with black text or blue with white text, are available as options.

Standard text size is 3/16", but 1/4", 3/8", and 1/2" are available as options. When dual units (starters or feeders) are supplied, two separate unit nameplates are supplied on each unit. An optional 2" tall by 6" wide or 2" tall by 8" wide master nameplate is available. Standard engraving on the master nameplate is three lines 1/2" tall characters. Optional 3/8" tall characters and various nameplate color options are available for the master nameplate.

Unit Nameplate Engraving Character Limit

Letter Height	Line 1	Line 2	Line 3	Line 4
3/16" Std.	25	18	25	—
3/16"	25	18	18	25
1/4"	18	16	18	NA
3/8"	16	16	NA	NA
1/2"	13	NA	NA	NA

For ordering blank nameplate kits, please see the MCC Aftermarket Renewal Parts Catalog.

Programmable Logic Controller (PLCs) Units and Human-Machine Interface (HMI) Options

A full line of Siemens PLC's (SIMATIC S7-300, S7-400, etc.) can be mounted in the tiastar motor control center. Siemens has the flexibility and expertise to provide a wide variety of configurations to meet user specified requirements for programmable logic control applications. HMI can also be installed in the tiastar line.

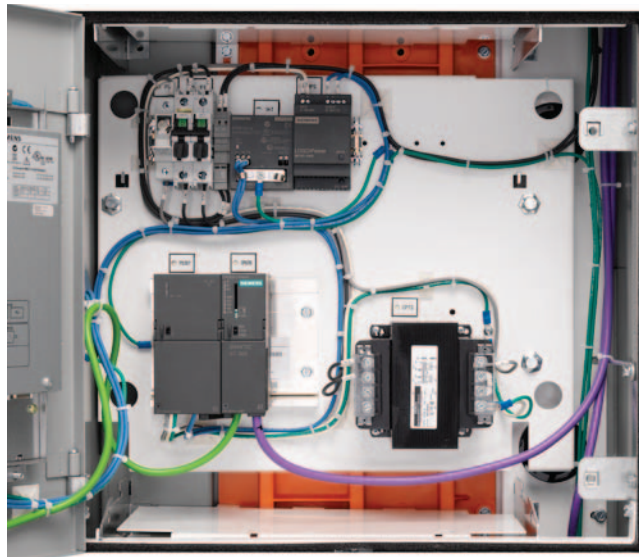



Metering Units

Advanced power monitoring devices are available for Siemens MCCs including SENTRON PAC3100, SENTRON PAC3200, and SENTRON PAC4200. Siemens line of power meters provides market leading technology for power quality measurement. These products continually change to meet growing needs for power quality and energy monitoring.

The PAC3100 and PAC3200 are powerful compact power monitoring devices that are suitable for use in industrial, government and commercial applications, where basic metering and energy monitoring is required. The meter may be used as a stand alone device monitoring over 25 (PAC3100) and over 50 (PAC3200) parameters or as part of an industrial control, building automation or global power monitoring system. Metering and monitoring applications range from simple analog volt and amp meter replacements to stand-alone sub-billing or cost allocation installation (PAC3200 offers this with multiple tariffs).

PAC3100

The PAC3100 has many features not usually found in this price class of meters. A large graphical display supports multiple languages and easy to use menus that can be used to set up the meter. The meter also has built in Modbus RTU communications via a RS485 interface. The meter comes standard with two digital inputs and outputs. One output is suitable for pulse output for export/import real and reactive energy. The other output is controllable from an outside source by way of a Modbus register.

Metering Units

PAC3200

The PAC3200 provides open communications using Modbus RTU/ TCP, PROFIBUS-DP, and PROFINET protocols for easy integration into any local or remote monitoring system. Simple configuration of the meter can be done from the front display.

PAC4200

The PAC4200 is a feature packed power monitoring device that is suitable for use in industrial, government and commercial applications where basic to advanced metering, logging, and I/O is required. The meter may be used as a standalone device monitoring over 200 parameters or as part of an industrial control, building automation or global enterprise wide monitoring system. Advanced power quality monitoring and logging applications range from single low voltage breaker / building metering to sub-station main feeder monitoring, sub-billing or cost allocation installations with multiple tariffs. Whether your goal is to reduce operation cost, reduce your carbon footprint or to maintain your power assets, the PAC 4200 meter should be an important part of your power monitoring system.

The PAC4200 provides open communication using the standard built-in Ethernet Modbus TCP and has the capability of communicating through Optional Modbus RTU, PROFIBUS-DP, and PROFINET protocol modules simultaneously. This allows for easy integration into any local or remote monitoring system. The gateway functionality of this device reduces installation cost by replacing other gateway devices and simplifying wiring.

Panelboard and Transformer Units

A Motor Control Center is principally intended to house multiple combination starters for the control of electrical motors. It is often convenient to include a limited number of power distribution units such as lighting panels and transformer units.

Lighting Panelboards Applied in MCCs

Amp Rating	Number of Circuits	Height in Inches (mm)		
		1Φ 3W 240/120	3Φ 4W 208Y/120	3Φ 4W 277/480

Main Lug Only/Main Circuit Breaker

125/250	18	30 (762)	30 (762)	30 (762)
	30	36 (914)	36 (914)	36 (914)
	42	42 (1067)	42 (1067)	42 (1067)

Distribution Transformers

KVA Rating	Phase	Unit Height in Inches (mm)
1	1	12 (305) ¹
1.5		
2		
3		
5		
7.5		18 (457) ²
10		
15		
25		
30		
37.5	24 (610) ^{2,3}	
45		
45	36 (914) ^{2,3}	
9		
15	3 ³	18 (457)
25		
30		
37.5		
45		
45	24 (610)	

1 Plate mounted.

2 Transformer mounted on brackets 6 in. (152 mm) off sills.

3 Requires 20 in. (508 mm) deep structure.





High Resistance Ground Unit Option

High Resistance Grounding (HRG) systems have gained in popularity in process application due to their ability to safely continue operation during a single line-ground fault and limit escalation of such a fault into a multi-phase event. Siemens HRG MCC unit limits the ground fault current which reduces the damage and stress to equipment and power system components.

Why you should use HRG

Protect Equipment	Limit ground fault current to less than 10A, reducing damage and stress to equipment and power system components.
Reduce Down Time	Process equipment can continue to operate in the event of a line to ground fault, increasing profitability.
Fast Fault Location	Pulsing circuit and optional ammeter allow for easier fault location, saving time and frustrations.

HRG Catalog Numbers

The HRG MCC unit consists of a Front Control Plate, the Internal Control Plate and an enclosed resistor.

All options are 2-10A, 60 Hz, 100kAIC, and include a Control Power Transformer.

Voltage (V)	Description
240 Delta	open resistors
	open resistors, SIS wire
240/139 Wye	open resistors
	open resistors, SIS wire
480 Delta	open resistors
	open resistors, SIS wire
480/277 Wye	open resistors
	open resistors, SIS wire
600 Delta	open resistors
	open resistors, SIS wire
600/347 Wye	open resistors
	open resistors, SIS wire



Feeder Circuit Breaker (FCB) Vertical Catalog Sections

Common tiastar sections are available as catalog numbers. Orders can be placed via Industry Mall or COMPAS. Sections are 480V, 65kA, 3 phase, 3 wire, NEMA 1A. Section dimensions are 90" high and 20" wide¹. Horizontal bus is tin plated and rated for 65°C. Sections include MCC installation manual. Wiring diagrams are available in the appendix.

FCB Vertical Section Numbering System



Class

8 P G 1 1 tiastar MCC Section

Section Characteristics

1 90" tall by 20" deep

Section type

- 3** Section with a 48" FCB unit
- 4** Section with a 72" FCB unit

Bus Ratings

- | | |
|--|---|
| B 600A Horizontal, 300A Vertical | E 800A Horizontal, 600A Vertical ² |
| C 600A Horizontal, 600A Vertical ² | F 1200A Horizontal, 300A Vertical |
| D 800A Horizontal, 300A Vertical | G 1200A Horizontal, 600A Vertical ² |

Circuit Breaker Frame

- | | |
|-----------------------------------|-----------------------------------|
| F 125A, 48" unit, 20" wide | R 250A, 72" unit, 20" wide |
| J 250A, 48" unit, 20" wide | S 400A, 72" unit, 30" wide |
| Q 125A, 72" unit, 20" wide | T 600A, 72" unit, 30" wide |

Circuit Breaker Trip Amps

0 3 30	1 7 175
0 5 40	1 8 200
0 7 50	2 0 225
0 8 60	2 1 250
1 0 70	2 2 300
1 1 80	2 3 350
1 2 90	2 4 400
1 3 100	2 5 450
1 5 125	2 6 500
1 6 150	2 7 600



Fixed with Vertical Bus



Fixed without Vertical Bus

¹ Unless otherwise specified

² 600A Vertical Bus options include shutter provisions

Note: All circuit breakers are calibrated for 40° C.

FCB Vertical Catalog Section Numbers

48" fixed mounted feeder circuit breaker with vertical bus and two 12" plug-in unit spaces

600A Horiz Bus, 300A Vert Bus, 125A Frame

30A Trip	8PG1113-1BF03
40A Trip	8PG1113-1BF05
50A Trip	8PG1113-1BF07
60A Trip	8PG1113-1BF08
70A Trip	8PG1113-1BF10
80A Trip	8PG1113-1BF11
90A Trip	8PG1113-1BF12
100A Trip	8PG1113-1BF13
125A Trip	8PG1113-1BF15

600A Horiz Bus, 300A Vert Bus, 250A Frame

150A Trip	8PG1113-1BJ16
175A Trip	8PG1113-1BJ17
200A Trip	8PG1113-1BJ18
225A Trip	8PG1113-1BJ20
250A Trip	8PG1113-1BJ21

600A Horiz Bus, 600A Vert Bus, 125A Frame

30A Trip, shutter provisions	8PG1113-1CF03
40A Trip, shutter provisions	8PG1113-1CF05
50A Trip, shutter provisions	8PG1113-1CF07
60A Trip, shutter provisions	8PG1113-1CF08
70A Trip, shutter provisions	8PG1113-1CF10
80A Trip, shutter provisions	8PG1113-1CF11
90A Trip, shutter provisions	8PG1113-1CF12
100A Trip, shutter provisions	8PG1113-1CF13
125A Trip, shutter provisions	8PG1113-1CF15

600A Horiz Bus, 600A Vert Bus, 250A Frame

150A Trip, shutter provisions	8PG1113-1CJ16
175A Trip, shutter provisions	8PG1113-1CJ17
200A Trip, shutter provisions	8PG1113-1CJ18
225A Trip, shutter provisions	8PG1113-1CJ20
250A Trip, shutter provisions	8PG1113-1CJ21

800A Horiz Bus, 300A Vert Bus, 125A Frame

30A Trip	8PG1113-1DF03
40A Trip	8PG1113-1DF05
50A Trip	8PG1113-1DF07
60A Trip	8PG1113-1DF08
70A Trip	8PG1113-1DF10
80A Trip	8PG1113-1DF11
90A Trip	8PG1113-1DF12
100A Trip	8PG1113-1DF13
125A Trip	8PG1113-1DF15

800A Horiz Bus, 300A Vert Bus, 250A Frame

150A Trip	8PG1113-1DJ16
175A Trip	8PG1113-1DJ17
200A Trip	8PG1113-1DJ18
225A Trip	8PG1113-1DJ20
250A Trip	8PG1113-1DJ21

800A Horiz Bus, 600A Vert Bus, 125A Frame

30A Trip, shutter provisions	8PG1113-1EF03
40A Trip, shutter provisions	8PG1113-1EF05
50A Trip, shutter provisions	8PG1113-1EF07
60A Trip, shutter provisions	8PG1113-1EF08
70A Trip, shutter provisions	8PG1113-1EF10
80A Trip, shutter provisions	8PG1113-1EF11
90A Trip, shutter provisions	8PG1113-1EF12
100A Trip, shutter provisions	8PG1113-1EF13
125A Trip, shutter provisions	8PG1113-1EF15

800A Horiz Bus, 600A Vert Bus, 250A Frame

150A Trip, shutter provisions	8PG1113-1EJ16
175A Trip, shutter provisions	8PG1113-1EJ17
200A Trip, shutter provisions	8PG1113-1EJ18
225A Trip, shutter provisions	8PG1113-1EJ20
250A Trip, shutter provisions	8PG1113-1EJ21

1200A Horiz Bus, 300A Vert Bus, 125A Frame

30A Trip	8PG1113-1FF03
40A Trip	8PG1113-1FF05
50A Trip	8PG1113-1FF07
60A Trip	8PG1113-1FF08
70A Trip	8PG1113-1FF10
80A Trip	8PG1113-1FF11
90A Trip	8PG1113-1FF12
100A Trip	8PG1113-1FF13
125A Trip	8PG1113-1FF15

1200A Horiz Bus, 300A Vert Bus, 250A Frame

150A Trip	8PG1113-1FJ16
175A Trip	8PG1113-1FJ17
200A Trip	8PG1113-1FJ18
225A Trip	8PG1113-1FJ20
250A Trip	8PG1113-1FJ21

Note: Shutter Provisions means that optional automatic shutters (8PG1191-2MA00) can be added to the vertical section by the customer.

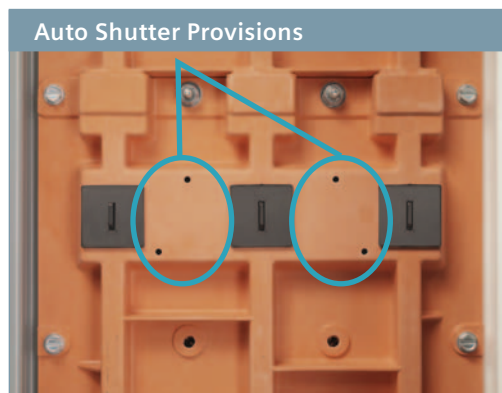

Note: Wiring diagrams in appendix.

FCB Vertical Catalog Section Numbers

48" fixed mounted feeder circuit breaker with vertical bus and two 12" plug-in unit spaces (cont.)

1200A Horiz Bus, 600A Vert Bus, 125A Frame

30A Trip, shutter provisions	8PG1113-1GF03
40A Trip, shutter provisions	8PG1113-1GF05
50A Trip, shutter provisions	8PG1113-1GF07
60A Trip, shutter provisions	8PG1113-1GF08
70A Trip, shutter provisions	8PG1113-1GF10
80A Trip, shutter provisions	8PG1113-1GF11
90A Trip, shutter provisions	8PG1113-1GF12
100A Trip, shutter provisions	8PG1113-1GF13
125A Trip, shutter provisions	8PG1113-1GF15

1200A Horiz Bus, 600A Vert Bus, 250A Frame

150A Trip, shutter provisions	8PG1113-1GJ16
175A Trip, shutter provisions	8PG1113-1GJ17
200A Trip, shutter provisions	8PG1113-1GJ18
225A Trip, shutter provisions	8PG1113-1GJ20
250A Trip, shutter provisions	8PG1113-1GJ21

72" fixed mounted feeder circuit breaker, without vertical bus

600 Horiz Bus, 125A Frame

30A Trip, 20" wide	8PG1114-1BQ03
40A Trip, 20" wide	8PG1114-1BQ05
50A Trip, 20" wide	8PG1114-1BQ07
60A Trip, 20" wide	8PG1114-1BQ08
70A Trip, 20" wide	8PG1114-1BQ10
80A Trip, 20" wide	8PG1114-1BQ11
90A Trip, 20" wide	8PG1114-1BQ12
100A Trip, 20" wide	8PG1114-1BQ13
125A Trip, 20" wide	8PG1114-1BQ15

600 Horiz Bus, 250A Frame

150A Trip, 20" wide	8PG1114-1BR16
175A Trip, 20" wide	8PG1114-1BR17
200A Trip, 20" wide	8PG1114-1BR18
225A Trip, 20" wide	8PG1114-1BR20
250A Trip, 20" wide	8PG1114-1BR21

600 Horiz Bus, 400A Frame

300A Trip, 30" wide	8PG1114-1BS22
350A Trip, 30" wide	8PG1114-1BS23
400A Trip, 30" wide	8PG1114-1BS24

600 Horiz Bus, 600A Frame

450A Trip, 30" wide	8PG1114-1BT25
500A Trip, 30" wide	8PG1114-1BT26
600A Trip, 30" wide	8PG1114-1BT27

800 Horiz Bus, 125A Frame

30A Trip, 20" wide	8PG1114-1DQ03
40A Trip, 20" wide	8PG1114-1DQ05
50A Trip, 20" wide	8PG1114-1DQ07
60A Trip, 20" wide	8PG1114-1DQ08
70A Trip, 20" wide	8PG1114-1DQ10
80A Trip, 20" wide	8PG1114-1DQ11
90A Trip, 20" wide	8PG1114-1DQ12
100A Trip, 20" wide	8PG1114-1DQ13
125A Trip, 20" wide	8PG1114-1DQ15

800 Horiz Bus, 250A Frame

150A Trip, 20" wide	8PG1114-1DR16
175A Trip, 20" wide	8PG1114-1DR17
200A Trip, 20" wide	8PG1114-1DR18
225A Trip, 20" wide	8PG1114-1DR20
250A Trip, 20" wide	8PG1114-1DR21

800 Horiz Bus, 400A Frame

300A Trip, 30" wide	8PG1114-1DS22
350A Trip, 30" wide	8PG1114-1DS23
400A Trip, 30" wide	8PG1114-1DS24

800 Horiz Bus, 600A Frame

450A Trip, 30" wide	8PG1114-1DT25
500A Trip, 30" wide	8PG1114-1DT26
600A Trip, 30" wide	8PG1114-1DT27

1200 Horiz Bus, 125A Frame

30A Trip, 20" wide	8PG1114-1FQ03
40A Trip, 20" wide	8PG1114-1FQ05
50A Trip, 20" wide	8PG1114-1FQ07
60A Trip, 20" wide	8PG1114-1FQ08
70A Trip, 20" wide	8PG1114-1FQ10
80A Trip, 20" wide	8PG1114-1FQ11
90A Trip, 20" wide	8PG1114-1FQ12
100A Trip, 20" wide	8PG1114-1FQ13
125A Trip, 20" wide	8PG1114-1FQ15

1200 Horiz Bus, 250A Frame

150A Trip, 20" wide	8PG1114-1FR16
175A Trip, 20" wide	8PG1114-1FR17
200A Trip, 20" wide	8PG1114-1FR18
225A Trip, 20" wide	8PG1114-1FR20
250A Trip, 20" wide	8PG1114-1FR21

1200 Horiz Bus, 400A Frame

300A Trip, 30" wide	8PG1114-1FS22
350A Trip, 30" wide	8PG1114-1FS23
400A Trip, 30" wide	8PG1114-1FS24

1200 Horiz Bus, 600A Frame

450A Trip, 30" wide	8PG1114-1FT25
500A Trip, 30" wide	8PG1114-1FT26
600A Trip, 30" wide	8PG1114-1FT27

Note: Wiring diagrams in appendix.

Blank, Panel, Main Lug Only (MLO), and Main Circuit Breaker (MCB) Vertical Catalog Sections

Common tiastar sections are available as catalog numbers. Orders can be placed via Industry Mall or COMPAS. Sections are 480V, 65kA, 3 phase, 3 wire, NEMA 1A. Section dimensions are 90" high and 20" wide¹. Horizontal bus is tin plated and rated for 65°C. Sections include MCC installation manual. Wiring diagrams are available in the appendix.

Blank Panel Vertical Section Numbering System



Class

8 P G 1 1 tiastar MCC Section

Section Characteristics

1 90 in. tall by 20in. deep

Section type

1 Section with or without an incoming cable compartment

Configuration **Horizontal Bus (A)** **Vertical Bus (A)** **Features**

Configuration	Horizontal Bus (A)	Vertical Bus (A)	Features
A A 0 0	600	300	six 12" blank spaces
A A 0 1	600	600	six 12" blank spaces ²
A A 1 0	800	300	six 12" blank spaces
A A 1 1	800	600	six 12" blank spaces ²
A A 2 0	1200	300	six 12" blank spaces
A A 2 1	1200	600	six 12" blank spaces ²
B A 0 0	600	—	72" high, 20 in. wide blank mounting panel
B A 1 0	800	—	72" high, 20 in. wide blank mounting panel
B A 2 0	1200	—	72" high, 20 in. wide blank mounting panel
B B 0 0	600	—	72" high, 30 in. wide blank mounting panel
B B 1 0	800	—	72" high, 30 in. wide blank mounting panel
B B 2 0	1200	—	72" high, 30 in. wide blank mounting panel
C A 0 1	600	600	600A MLO Top Entry ²
C A 1 1	800	600	800A MLO Top Entry ²
C A 2 1	1200	600	1200A MLO Top Entry ²
C B 0 1	600	600	600A MLO Bottom Entry ²
C B 1 1	800	600	800A MLO Bottom Entry ²
C B 2 1	1200	600	1200A MLO Bottom Entry ²
D A 0 1	600	600	600A MCB Top Entry ²
D A 1 1	800	600	800A MCB Top Entry ²
D A 2 1	1200	600	1200A MCB Top Entry ²
D B 0 1	600	600	600A MCB Bottom Entry ²
D B 1 1	800	600	800A MCB Bottom Entry ²
D B 2 1	1200	600	1200A MCB Bottom Entry ²



Blank Vertical Catalog Section

¹ Unless otherwise specified

² 600A Vertical Bus options include shutter provisions

Note: All circuit breakers are calibrated for 40° C.

Blank, Panel, MLO, and MCB Vertical Sections

Product Description	Catalog Number
Blank Vertical Sections with six 12" plug-in unit spaces (see Figure 55)	
600A Horiz Bus, 300A Vert Bus	8PG1111-1AA00
600A Horiz Bus, 600A Vert Bus, shutter provisions	8PG1111-1AA01
800A Horiz Bus, 300A Vert Bus	8PG1111-1AA10
800A Horiz Bus, 600A Vert Bus, shutter provisions	8PG1111-1AA11
1200A Horiz Bus, 300A Vert Bus	8PG1111-1AA20
1200A Horiz Bus, 600A Vert Bus, shutter provisions	8PG1111-1AA21
Mounting Panel Vertical Section (see Figure 56)	
20" wide, 600A Horiz Bus	8PG1111-1BA00
20" wide, 800A Horiz Bus	8PG1111-1BA10
20" wide, 1200A Horiz Bus	8PG1111-1BA20
30" wide, 600A Horiz Bus	8PG1111-1BB00
30" wide, 800A Horiz Bus	8PG1111-1BB10
30" wide, 1200A Horiz Bus	8PG1111-1BB20
Main Lug Only (MLO) Vertical Sections (see Figure 57)	
Top MLO	
600A Lugs, 600A Horiz Bus, 600A Vert Bus, shutter provisions	8PG1111-1CA01
800A Lugs, 800A Horiz Bus, 600A Vert Bus, shutter provisions	8PG1111-1CA11
1200A Lugs, 1200A Horiz Bus, 600A Vert Bus, shutter provisions	8PG1111-1CA21
Bottom MLO	
600A Lugs, 600A Horiz Bus, 600A Vert Bus, shutter provisions	8PG1111-1CB01
800A Lugs, 800A Horiz Bus, 600A Vert Bus, shutter provisions	8PG1111-1CB11
1200A Lugs, 1200A Horiz Bus, 600A Vert Bus, shutter provisions	8PG1111-1CB21
Main Circuit Breaker (MCB) Vertical Sections (see Figure 58)	
Top MCB	
600A Frame, 600A Trip, 600A Horiz Bus, 600A Vert Bus, shutter provisions	8PG1111-1DA01
800A Frame, 800A Trip, 800A Horiz Bus, 600A Vert Bus, shutter provisions	8PG1111-1DA11
1200A Frame, 1200A Trip, 1200A Horiz Bus, 600A Vert Bus, shutter provisions	8PG1111-1DA21
Bottom MCB	
600A Frame, 600A Trip, 600A Horiz Bus, 600A Vert Bus, shutter provisions	8PG1111-1DB01
800A Frame, 800A Trip, 800A Horiz Bus, 600A Vert Bus, shutter provisions	8PG1111-1DB11
1200A Frame, 1200A Trip, 1200A Horiz Bus, 600A Vert Bus, shutter provisions	8PG1111-1DB21

Note: Wiring diagrams in appendix.

MCC Standard Sections



Figure 55:
Blank Section



Figure 56:
Mounting Panel



Figure 57:
Main Lug Only (MLO)



Figure 58:
Main Circuit Breaker (MCB)

Feeder Circuit Breaker (FCB) Catalog Units

Common tiastar FCB units are available as catalog numbers. Orders can be placed via Industry Mall or COMPAS. Units are 480V, 60Hz, NEMA 12. Units include: door, wiring diagram, and unit installation manual. Wiring diagrams are available in the appendix.

FCB Catalog Numbering System



Class

8 P G 1 1 tiastar MCC

Unit Size

- 1** Standard
- 2** High Density

Compartment type

2 Plug-in units

Overload Type

1 None

Product type

- B** FCB
- C** FCB units designed for G120/G120C VFD mounting

Ratings and Unit Size at 480V

- A** 65K 125A 6"
- B** 65K 125A 12"
- C** 65K 125A 18"
- D** 65K 125A 24"
- E** 65K 125A 36"
- F** 65K 125A 48"
- G** 65K 250A 18"
- H** 65K 250A 24"
- I** 65K 250A 36"
- J** 65K 250A 48"
- K** 65K 250A 60"
- L** 100K 250A 24"
- M** 100K 250A 36"
- N** 100K 250A 48"
- P** 100K 250A 60"

Circuit Breaker Trip Amps

0	0	15	
0	0	1	20
0	0	2	25
0	0	3	30
0	0	4	35
0	0	5	40
0	0	6	45
0	0	7	50
0	0	8	60
1	0	70	
1	1	80	
1	1	2	90
1	1	3	100
1	1	4	110
1	1	5	125
1	1	6	150
1	1	7	175
1	1	8	200
2	0	225	
2	1	250	

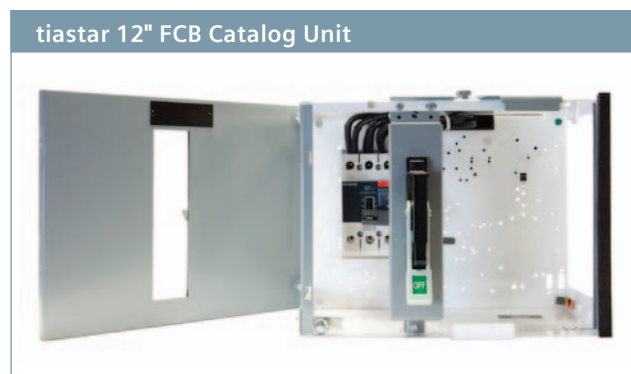
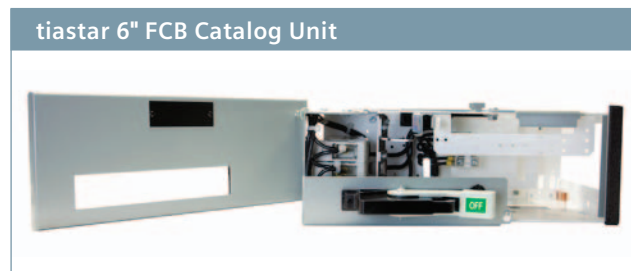

Note: All circuit breakers are calibrated for 40° C.

FCB Catalog Numbers

Product Description	Catalog Number
480V 65K 125A 6" High Density	
15A	8PG1122-1BA00
20A	8PG1122-1BA01
25A	8PG1122-1BA02
30A	8PG1122-1BA03
35A	8PG1122-1BA04
40A	8PG1122-1BA05
45A	8PG1122-1BA06
50A	8PG1122-1BA07
60A	8PG1122-1BA08
70A	8PG1122-1BA10
80A	8PG1122-1BA11
90A	8PG1122-1BA12
100A	8PG1122-1BA13
110A	8PG1122-1BA14
125A	8PG1122-1BA15
480V 65K 125A 12"	
15A	8PG1112-1BB00
20A	8PG1112-1BB01
25A	8PG1112-1BB02
30A	8PG1112-1BB03
35A	8PG1112-1BB04
40A	8PG1112-1BB05
45A	8PG1112-1BB06
50A	8PG1112-1BB07
60A	8PG1112-1BB08
70A	8PG1112-1BB10
80A	8PG1112-1BB11
90A	8PG1112-1BB12
100A	8PG1112-1BB13
110A	8PG1112-1BB14
125A	8PG1112-1BB15
480V 65K 125A 18"	
15A	8PG1112-1BC00
20A	8PG1112-1BC01
25A	8PG1112-1BC02
30A	8PG1112-1BC03
35A	8PG1112-1BC04
40A	8PG1112-1BC05
45A	8PG1112-1BC06
50A	8PG1112-1BC07
60A	8PG1112-1BC08
70A	8PG1112-1BC10
80A	8PG1112-1BC11
90A	8PG1112-1BC12
100A	8PG1112-1BC13
110A	8PG1112-1BC14
125A	8PG1112-1BC15

Product Description	Catalog Number
480V 65K 125A 24"	
15A	8PG1112-1BD00
20A	8PG1112-1BD01
25A	8PG1112-1BD02
30A	8PG1112-1BD03
35A	8PG1112-1BD04
40A	8PG1112-1BD05
45A	8PG1112-1BD06
50A	8PG1112-1BD07
60A	8PG1112-1BD08
70A	8PG1112-1BD10
80A	8PG1112-1BD11
90A	8PG1112-1BD12
100A	8PG1112-1BD13
110A	8PG1112-1BD14
125A	8PG1112-1BD15
480V 65K 125A 36"	
15A	8PG1112-1BE00
20A	8PG1112-1BE01
25A	8PG1112-1BE02
30A	8PG1112-1BE03
35A	8PG1112-1BE04
40A	8PG1112-1BE05
45A	8PG1112-1BE06
50A	8PG1112-1BE07
60A	8PG1112-1BE08
70A	8PG1112-1BE10
80A	8PG1112-1BE11
90A	8PG1112-1BE12
100A	8PG1112-1BE13
110A	8PG1112-1BE14
125A	8PG1112-1BE15
480V 65K 125A 48"	
15A	8PG1112-1BF00
20A	8PG1112-1BF01
25A	8PG1112-1BF02
30A	8PG1112-1BF03
35A	8PG1112-1BF04
40A	8PG1112-1BF05
45A	8PG1112-1BF06
50A	8PG1112-1BF07
60A	8PG1112-1BF08
70A	8PG1112-1BF10
80A	8PG1112-1BF11
90A	8PG1112-1BF12
100A	8PG1112-1BF13
110A	8PG1112-1BF14
125A	8PG1112-1BF15

Note: Wiring diagrams in appendix.

FCB Catalog Numbers

480V 65K 250A 18"

150A	8PG1112-1BG16
175A	8PG1112-1BG17
200A	8PG1112-1BG18
225A	8PG1112-1BG20
250A	8PG1112-1BG21

480V 65K 250A 24"

150A	8PG1112-1BH16
175A	8PG1112-1BH17
200A	8PG1112-1BH18
225A	8PG1112-1BH20
250A	8PG1112-1BH21

480V 65K 250A 36"

150A	8PG1112-1BI16
175A	8PG1112-1BI17
200A	8PG1112-1BI18
225A	8PG1112-1BI20
250A	8PG1112-1BI21

480V 65K 250A 48"

150A	8PG1112-1BJ16
175A	8PG1112-1BJ17
200A	8PG1112-1BJ18
225A	8PG1112-1BJ20
250A	8PG1112-1BJ21

480V 65K 250A 60"

150A	8PG1112-1BK16
175A	8PG1112-1BK17
200A	8PG1112-1BK18
225A	8PG1112-1BK20
250A	8PG1112-1BK21

480V 100K 250A 24"

150A	8PG1112-1BL16
175A	8PG1112-1BL17
200A	8PG1112-1BL18
225A	8PG1112-1BL20
250A	8PG1112-1BL21

480V 100K 250A 36"

150A	8PG1112-1BM16
175A	8PG1112-1BM17
200A	8PG1112-1BM18
225A	8PG1112-1BM20
250A	8PG1112-1BM21

480V 100K 250A 48"

150A	8PG1112-1BN16
175A	8PG1112-1BN17
200A	8PG1112-1BN18
225A	8PG1112-1BN20
250A	8PG1112-1BN21

480V 100K 250A 60"

150A	8PG1112-1BP16
175A	8PG1112-1BP17
200A	8PG1112-1BP18
225A	8PG1112-1BP20
250A	8PG1112-1BP21

G120/G120C Oversized FCB Catalog Units

18" for G120/G120C

18" plug-in unit, 15 A	8PG1112-1CC00
------------------------	---------------

24" for G120/G120C

24" plug-in unit, 15A	8PG1112-1CD00
24" plug-in unit, 20A	8PG1112-1CD01
24" plug-in unit, 25A	8PG1112-1CD02

36" for G120/G120C

36" plug-in unit, 15A	8PG1112-1CE00
36" plug-in unit, 20A	8PG1112-1CE01
36" plug-in unit, 25A	8PG1112-1CE02
36" plug-in unit, 30A	8PG1112-1CE03
36" plug-in unit, 35A	8PG1112-1CE04
36" plug-in unit, 40A	8PG1112-1CE05
36" plug-in unit, 45A	8PG1112-1CE06
36" plug-in unit, 50A	8PG1112-1CE07

NOTE: Drive not included.

tiastar G120/G120C Oversized FCB Catalog Unit



Note: Wiring diagrams in appendix.

Full Voltage Non-Reversing (FVNR) Catalog Units

Common tiastar FVNR units are available as catalog numbers. Orders can be placed via Industry Mall or COMPAS. Units are 480V, 60Hz, NEMA 12, Type 1 B-d Wiring, 100kAIC. Units include: 1 N.O./1 N.C. auxiliary contacts, pilot device housing for up to four 22 mm devices, door, wiring diagram, and unit installation manual. Wiring diagrams are available in the appendix.

FVNR Catalog Numbering System



Class

8 P G 1 1 tiastar MCC

Unit Size

- 1** Standard
- 2** High Density

Compartment type

- 2** Plug-in units

Overload type

- 1** ESP200
- 2** SIMOCODE pro C¹²
- 3** SIMOCODE pro V¹²

Product type

A FVNR

Horsepower

A 0 0	1/4
A 0 1	1/3
A 0 2	1/2
A 0 3	3/4-1
A 0 4	1.5
A 0 5	2-3
A 0 6	4
A 0 7	5
A 0 8	7.5-10
A 1 0	15-20
A 1 1	25
A 1 2	30
A 1 3	40-50
A 1 4	60-75
A 1 5	100

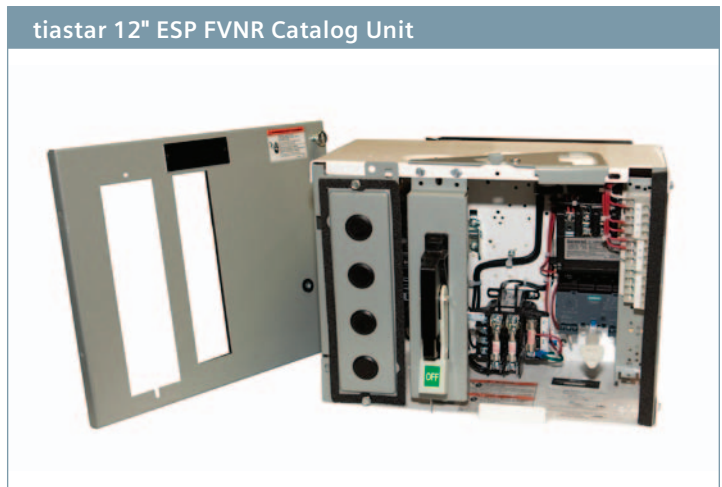

1 Includes Current Only Module
2 Not available with High Density

Note: All circuit breakers are calibrated for 40° C.

FVNR Catalog Numbers

Product Description **Catalog Number**

High Density ESP200 Overload Units	
6", 1/4 HP HD-FVNR SIZE 1, 1A ETI CB, ESP200 0.25-1A, CPT	8PG1122-1AA00
6", 1/3 HP HD-FVNR SIZE 1, 2A ETI CB, ESP200 0.25-1A, CPT	8PG1122-1AA01
6", 1/2 HP HD-FVNR SIZE 1, 3A ETI CB, ESP200 0.75-3.4A, CPT	8PG1122-1AA02
6", 3/4 - 1 HP HD-FVNR SIZE 1, 5A ETI CB, ESP200 0.75-3.4A, CPT	8PG1122-1AA03
6", 1.5 HP HD-FVNR SIZE 1, 10A ETI CB, ESP200 0.75-3.4A, CPT	8PG1122-1AA04
6", 2 - 3 HP HD-FVNR SIZE 1, 10A ETI CB, ESP200 3-12A, CPT	8PG1122-1AA05
6", 4 HP HD-FVNR SIZE 1, 25A ETI CB, ESP200 3-12A, CPT	8PG1122-1AA06
6", 5 HP HD-FVNR SIZE 1, 30A ETI CB, ESP200 3-12A, CPT	8PG1122-1AA07
6", 7.5 - 10 HP HD-FVNR SIZE 1, 40A ETI CB, ESP200 5.5-22A, CPT	8PG1122-1AA08
6", 15 - 20 HP HD-FVNR SIZE 2, 50A ETI CB, ESP200 10-40A, CPT	8PG1122-1AA10
6", 25 HP HD-FVNR SIZE 2, 100A ETI CB, ESP200 10-40A, CPT	8PG1122-1AA11
12", 30 HP HD-FVNR SIZE 3, 100A ETI CB, ESP200 25-100A, CPT	8PG1122-1AA12
12", 40 - 50 HP HD-FVNR SIZE 3, 125A ETI CB, ESP200 25-100A, CPT	8PG1122-1AA13
ESP200 Overload Units	
12", 1/4 HP FVNR SIZE 1, 1A ETI CB, ESP200 0.25-1A, CPT	8PG1112-1AA00
12", 1/3 HP FVNR SIZE 1, 2A ETI CB, ESP200 0.25-1A, CPT	8PG1112-1AA01
12", 1/2 HP FVNR SIZE 1, 3A ETI CB, ESP200 0.75-3.4A, CPT	8PG1112-1AA02
12", 3/4 - 1 HP FVNR SIZE 1, 5A ETI CB, ESP200 0.75-3.4A, CPT	8PG1112-1AA03
12", 1.5 HP FVNR SIZE 1, 10A ETI CB, ESP200 0.75-3.4A, CPT	8PG1112-1AA04
12", 2 - 3 HP FVNR SIZE 1, 10A ETI CB, ESP200 3-12A, CPT	8PG1112-1AA05
12", 4 HP FVNR SIZE 1, 25A ETI CB, ESP200 3-12A, CPT	8PG1112-1AA06
12", 5 HP FVNR SIZE 1, 30A ETI CB, ESP200 3-12A, CPT	8PG1112-1AA07
12", 7.5 - 10 HP FVNR SIZE 1, 40A ETI CB, ESP200 5.5-22A, CPT	8PG1112-1AA08
12", 15 - 20 HP FVNR SIZE 2, 50A ETI CB, ESP200 13-52A, CPT	8PG1112-1AA10
12", 25 HP FVNR SIZE 2, 100A ETI CB, ESP200 13-52A, CPT	8PG1112-1AA11
18", 30 HP FVNR SIZE 3, 100A ETI CB, ESP200 25-100A, CPT	8PG1112-1AA12
18", 40 - 50 HP FVNR SIZE 3, 125A ETI CB, ESP200 25-100A, CPT	8PG1112-1AA13
24", 60 - 75 HP FVNR SIZE 4, 150A ETI CB, ESP200 50-200A, CPT	8PG1112-1AA14
24", 100 HP FVNR SIZE 4, 250A ETI CB, ESP200 50-200A, CPT	8PG1112-1AA15

Note: Wiring diagrams in appendix.

FVNR Catalog Numbers

Product Description	Catalog Number
SIMOCODE PRO C^{1 2 3}	
12", 1/4 HP FVNR SIZE 1, 1A ETI CB, SIMOCODE PRO C 0.3-3 AMPS, CPT	8PG1112-2AA00
12", 1/3 HP FVNR SIZE 1, 2A ETI CB, SIMOCODE PRO C 0.3-3 AMPS, CPT	8PG1112-2AA01
12", 1/2 HP FVNR SIZE 1, 3A ETI CB, SIMOCODE PRO C 0.3-3 AMPS, CPT	8PG1112-2AA02
12", 3/4 - 1 HP FVNR SIZE 1, 5A ETI CB, SIMOCODE PRO C 0.3-3 AMPS, CPT	8PG1112-2AA03
12", 1.5 HP FVNR SIZE 1, 10A ETI CB, SIMOCODE PRO C 2.4-25 AMPS, CPT	8PG1112-2AA04
12", 2 - 3 HP FVNR SIZE 1, 10A ETI CB, SIMOCODE PRO C 2.4-25 AMPS, CPT	8PG1112-2AA05
12", 4 HP FVNR SIZE 1, 25A ETI CB, SIMOCODE PRO C 2.4-25 AMPS, CPT	8PG1112-2AA06
12", 5 HP FVNR SIZE 1, 30A ETI CB, SIMOCODE PRO C 2.4-25 AMPS, CPT	8PG1112-2AA07
12", 7.5 - 10 HP FVNR SIZE 1, 40A ETI CB, SIMOCODE PRO C 2.4-25 AMPS, CPT	8PG1112-2AA08
12", 15 - 20 HP FVNR SIZE 2, 50A ETI CB, SIMOCODE PRO C 10-100 AMPS, CPT	8PG1112-2AA10
12", 25 HP FVNR SIZE 2, 100A ETI CB, SIMOCODE PRO C 10-100 AMPS, CPT	8PG1112-2AA11
18", 30 HP FVNR SIZE 3, 100A ETI CB, SIMOCODE PRO C 10-100 AMPS, CPT	8PG1112-2AA12
18", 40 - 50 HP FVNR SIZE 3, 125A ETI CB, SIMOCODE PRO C 10-100 AMPS, CPT	8PG1112-2AA13
24", 60 - 75 HP FVNR SIZE 4, 150A ETI CB, SIMOCODE PRO C 20-200 AMPS, CPT	8PG1112-2AA14
24", 100 HP FVNR SIZE 4, 250A ETI CB, SIMOCODE PRO C 20-200 AMPS, CPT	8PG1112-2AA15
SIMOCODE PRO V^{1 2 3}	
12", 1/4 HP FVNR SIZE 1, 1A ETI CB, SIMOCODE PRO V 0.3-3 AMPS, CPT	8PG1112-3AA00
12", 1/3 HP FVNR SIZE 1, 2A ETI CB, SIMOCODE PRO V 0.3-3 AMPS, CPT	8PG1112-3AA01
12", 1/2 HP FVNR SIZE 1, 3A ETI CB, SIMOCODE PRO V 0.3-3 AMPS, CPT	8PG1112-3AA02
12", 3/4 - 1 HP FVNR SIZE 1, 5A ETI CB, SIMOCODE PRO V 0.3-3 AMPS, CPT	8PG1112-3AA03
12", 1.5 HP FVNR SIZE 1, 10A ETI CB, SIMOCODE PRO V 2.4-25 AMPS, CPT	8PG1112-3AA04
12", 2 - 3 HP FVNR SIZE 1, 10A ETI CB, SIMOCODE PRO V 2.4-25 AMPS, CPT	8PG1112-3AA05
12", 4 HP FVNR SIZE 1, 25A ETI CB, SIMOCODE PRO V 2.4-25 AMPS, CPT	8PG1112-3AA06
12", 5 HP FVNR SIZE 1, 30A ETI CB, SIMOCODE PRO V 2.4-25 AMPS, CPT	8PG1112-3AA07
12", 7.5 - 10 HP FVNR SIZE 1, 40A ETI CB, SIMOCODE PRO V 2.4-25 AMPS, CPT	8PG1112-3AA08
12", 15 - 20 HP FVNR SIZE 2, 50A ETI CB, SIMOCODE PRO V 10-100 AMPS, CPT	8PG1112-3AA10
12", 25 HP FVNR SIZE 2, 100A ETI CB, SIMOCODE PRO V 10-100 AMPS, CPT	8PG1112-3AA11
18", 30 HP FVNR SIZE 3, 100A ETI CB, SIMOCODE PRO V 10-100 AMPS, CPT	8PG1112-3AA12
18", 40 - 50 HP FVNR SIZE 3, 125A ETI CB, SIMOCODE PRO V 10-100 AMPS, CPT	8PG1112-3AA13
24", 60 - 75 HP FVNR SIZE 4, 150A ETI CB, SIMOCODE PRO V 20-200 AMPS, CPT	8PG1112-3AA14
24", 100 HP FVNR SIZE 4, 250A ETI CB, SIMOCODE PRO V 20-200 AMPS, CPT	8PG1112-3AA15

Note: Wiring diagrams in appendix.

1 Includes Current Only Module

2 Not available with High Density

3 Includes Base Unit Only

Common Modification Kits

Common modification kits includes pilot device(s), 16 gauge MTW wiring, wire tie, anchor, legend plate, wiring diagram, and installation guide.

Product Name	Kit Type
Pushbutton	Product MLFB
22MM Start - Stop Pushbutton Kit	8PG1182-1KA00
22MM Emergency Stop Pushbutton Kit ¹	8PG1182-1KA01
30MM Start - Stop Pushbutton Kit	8PG1182-1KA02
30MM Emergency Stop Pushbutton Kit ¹	8PG1182-1KA03

Selector Switch	Product MLFB
22MM Hand - Off - Auto Selector Switch Kit	8PG1182-1KB00
22MM Start - Stop Selector Switch Kit	8PG1182-1KB01
22MM Off - On Selector Switch Kit	8PG1182-1KB02
30MM Hand - Off - Auto Selector Switch Kit	8PG1182-1KB03
30MM Start - Stop Selector Switch Kit	8PG1182-1KB04
30MM Off - On Selector Switch Kit	8PG1182-1KB05

Pilot Lights	Product MLFB
22MM Off Pilot Light 120V Kit	8PG1182-1KC00
22MM On - Off Pilot Lights 120V Kit	8PG1182-1KC01
22MM Running - Off Pilot Lights 120V Kit	8PG1182-1KC02
22MM Running Pilot Light 120V Kit	8PG1182-1KC03
22MM Push-To-Test On Pilot Light 120V Kit	8PG1182-1KC06
22MM Push-To-Test On - Off Pilot Lights 120V Kit	8PG1182-1KC07
30MM Off Pilot Light 120V Kit	8PG1182-1KC11
30MM On - Off Pilot Lights 120V Kit	8PG1182-1KC12
30MM Running - Off Pilot Lights 120V Kit	8PG1182-1KC13
30MM Running Pilot Light 120V Kit	8PG1182-1KC14
30MM Led Running Pilot Light 120V Kit	8PG1182-1KC15
30MM Led On - Off Pilot Lights 120V Kit	8PG1182-1KC16
30MM Push-To-Test On Pilot Light 120V Kit	8PG1182-1KC17
30MM Push-To-Test On - Off Pilot Lights 120V Kit	8PG1182-1KC18
30MM Led Push-To-Test On Pilot Light 120V Kit	8PG1182-1KC20
30MM Led Push-To-Test On - Off Pilot Lights 120V Kit	8PG1182-1KC21

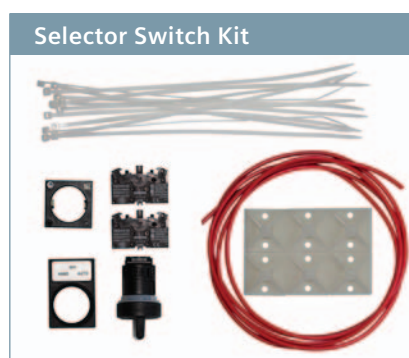
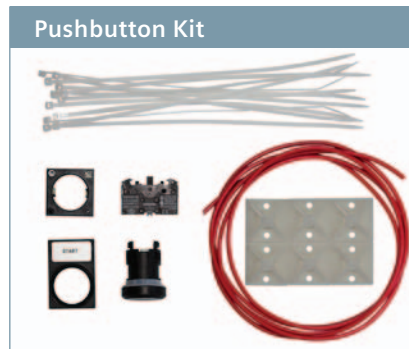

NOTE: Standard 30MM Nema 1 Pilot Device Housing Kit (8PG1192-1DF06) and 30MM Nema 12 Pilot Device Housing Kit (8PG1192-1DF07) are available.

¹ For an emergency stop device according to EN 418, please see the industrial controls catalog.

Other Modification Kits



To order other parts for MCC modifications, refer to the "tiastar and legacy Motor Control Center Aftermarket Renewal Parts Catalog" which is literature order number MCCS-AFTMKT-0613. Find information on ordering Splice kits, Drip Shield kits, Door kits, Terminal Blocks, etc.

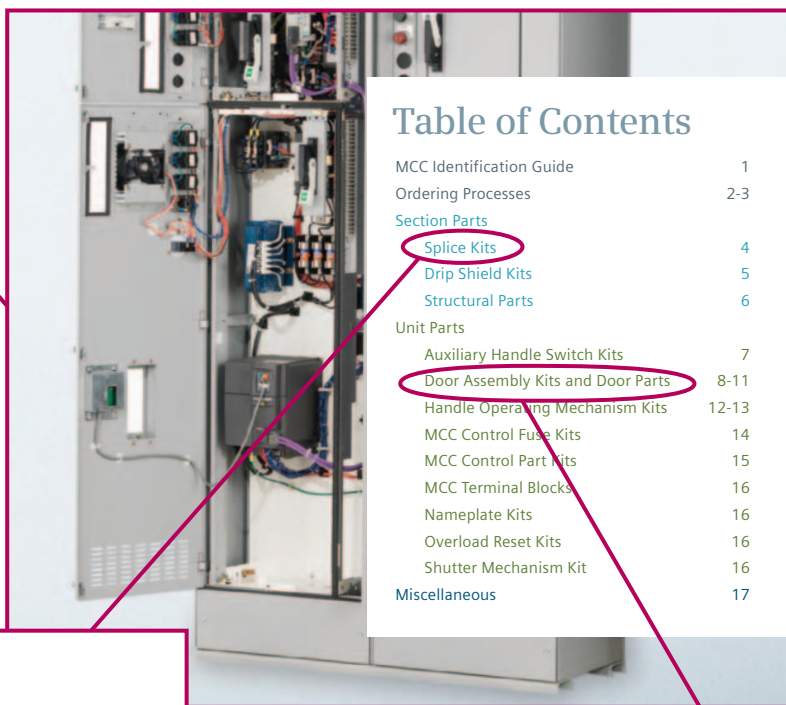

Section Parts

Splice Kits

Bus splice plate(s), mounting hardware, and installation guide are included in the Splice Kit.



50°C Horizontal Bus Silver Plated Kit Type	Ordering Number
600A	8PG1191-2KA00
800A	8PG1191-2KA01
1200A	8PG1191-2KA02
1600A	8PG1191-2KA03
2000A	8PG1191-2KA04
2500A	8PG1191-2KA05

50°C Horizontal Bus Tin Plated Kit Type	Ordering Number
600A	8PG1191-2KB00
800A	8PG1191-2KB01
1200A	8PG1191-2KB02
1600A	8PG1191-2KB03
2000A	8PG1191-2KB04
2500A	8PG1191-2KB05

Neutral Bus Kit Type	Ordering Number
600A, Silver Plated	8PG1191-2KC00
800A, Silver Plated	8PG1191-2KC01
600A, Tin Plated	8PG1191-2KC02
800A, Tin Plated	8PG1191-2KC03

Ground Bus Kit Type	Ordering Number
300A, Top Mounted, Bare Copper	8PG1191-2KD00
600A, Top Mounted, Bare Copper	8PG1191-2KD01
300A, Bottom Mounted, Bare Copper	8PG1191-2KD02
600A, Bottom Mounted, Bare Copper	8PG1191-2KD03
300A, Top Mounted, Tin Plated	8PG1191-2KD04
600A, Top Mounted, Tin Plated	8PG1191-2KD05
300A, Bottom Mounted, Tin Plated	8PG1191-2KD06
600A, Bottom Mounted, Tin Plated	8PG1191-2KD07

65°C Horizontal Bus Silver Plated Kit Type	Ordering Number
600A	8PG1191-2KE00
800A	8PG1191-2KE01
1200A	8PG1191-2KE02

65°C Horizontal Bus Tin Plated Kit Type	Ordering Number
600A	8PG1191-2KF00
800A	8PG1191-2KF01
1200A	8PG1191-2KF02

Unit Parts

Door Assembly Kits and Door Parts—Model 95+ and System 89/tiastar

Door, hinges, and mounting hardware included in the Model 95+ and System 89/tiastar Door Assembly Kit.

Vertical Wireway Door Kit Type	Ordering Number
4" Wide By 12" Tall	8PG1192-1DD00
4" Wide By 18" Tall	8PG1192-1DD01
4" Wide By 24" Tall	8PG1192-1DD02
4" Wide By 30" Tall	8PG1192-1DD03
4" Wide By 36" Tall	8PG1192-1DD04
4" Wide By 42" Tall	8PG1192-1DD05
4" Wide By 48" Tall	8PG1192-1DD06
4" Wide By 54" Tall	8PG1192-1DD07
4" Wide By 60" Tall	8PG1192-1DD08
4" Wide By 66" Tall	8PG1192-1DD10
4" Wide By 72" Tall	8PG1192-1DD11
8" Wide By 12" Tall	8PG1192-1DD12
8" Wide By 18" Tall	8PG1192-1DD13
8" Wide By 24" Tall	8PG1192-1DD14

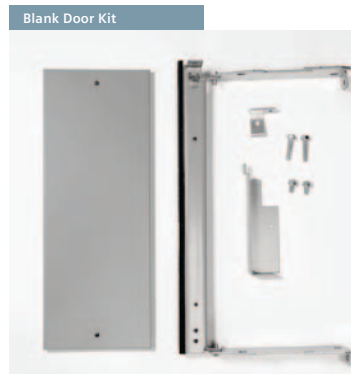

Door Kit Type	Ordering Number
6" High Density Unit Door Kit	8PG1192-1DE00
15" Wide By 6" Tall Filler Door	8PG1192-1DE01
15" Wide By 12" Tall Blank Door	8PG1192-1DE03
15" Wide By 18" Tall Blank Door	8PG1192-1DE04
15" Wide By 24" Tall Blank Door	8PG1192-1DE05
15" Wide By 30" Tall Blank Door	8PG1192-1DE06
15" Wide By 36" Tall Blank Door	8PG1192-1DE07

Dimensions and Drawings

Structures

The standards structure is 90" (2286 mm) high, plus a 1.125" (29 mm) high channel sill. Front-only (FO) structures can be either 15" (381 mm) or 20" (508 mm) deep. Siemens provides a 21" (533mm) true back-to-back (BTB) design, consisting of a common horizontal and vertical bus structure, for applications where available footprint is limited. Moreover, we provide other back-to-back (BTB) mounted double deep structures which are 30.5" (775 mm) or 40.5" (1029 mm) deep, and consist of two horizontal and vertical buses. This allows for correct bus phasing on the front or rear. The standards structure is 90" (2286 mm) high, plus a 1.125" (29 mm) high channel sill. Front-only (FO) structures can be either 15" (381 mm) or 20" (508 mm) deep.

Structure	
Height	NEMA 1, 2, or 12 91.125" (2315mm)
	NEMA 3R 100" (2540 mm)
Front Mounted Only Structure (FO)	
Width	20" (508 mm) 24" (610 mm) 30" (762 mm)
Depth	15" (381 mm) 20" (508 mm)
Back-to-Back Structure	
Width	20" (508 mm) 30" (762 mm)
Depth	21" (533 mm)
Double Deep Structure	
Width	20" (508 mm) 30" (762 mm)
Depth	30.5" (775 mm) 40.5" (1029 mm)

Vertical Wireway	
Height	72" (1829 mm)
Width	4" (102 mm)
Depth	9" (229mm)
Cross Section	36 sq." (914 sq. mm)
Top Horizontal Wireway	
Height	12" (305 mm)
Depth	7" (178 mm)
Bottom Horizontal Wireway	
Height	6" (305 mm)
Depth	15" (381 mm) 20" (508 mm) 30" (762 mm)
Pull Box (Top Hat)	
Height	12" (305 mm) 18" (457 mm) 24" (610 mm)
Width	20" (508 mm) 30" (762 mm)
Depth	15" (381 mm) 20" (508 mm)

Bus Drawings

Available Locations Of Ground And Full Length Neutral

Section	Neutral	Ground
Typical	CD	ABCD
With Vertical Ground Bus	C	AC
Main Lug Only	CD	BCD
Main Disconnect	CD	BCD
Service Entrance	C	ABCD

Notes:

1. Location B and D is available on 21" back-to-back structures only.
2. When continuous (full length) neutral bus is specified, it must be located in the bottom of the structure. Full length neutral bus requires that the ground be located in the top of the structure. The standard location is C.

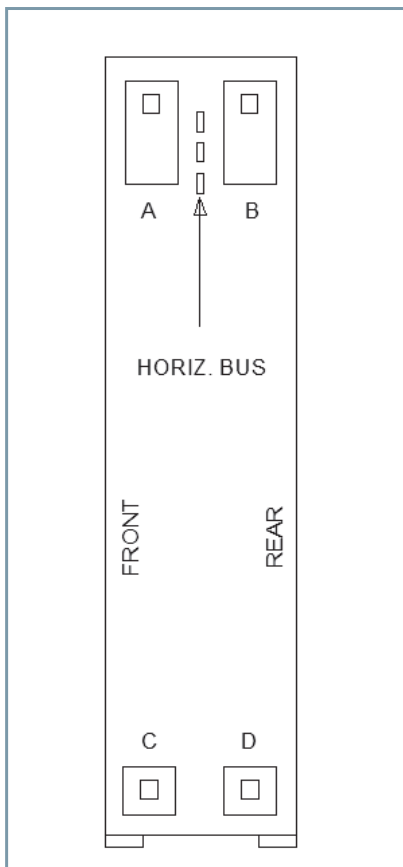

Figure 59. Side View

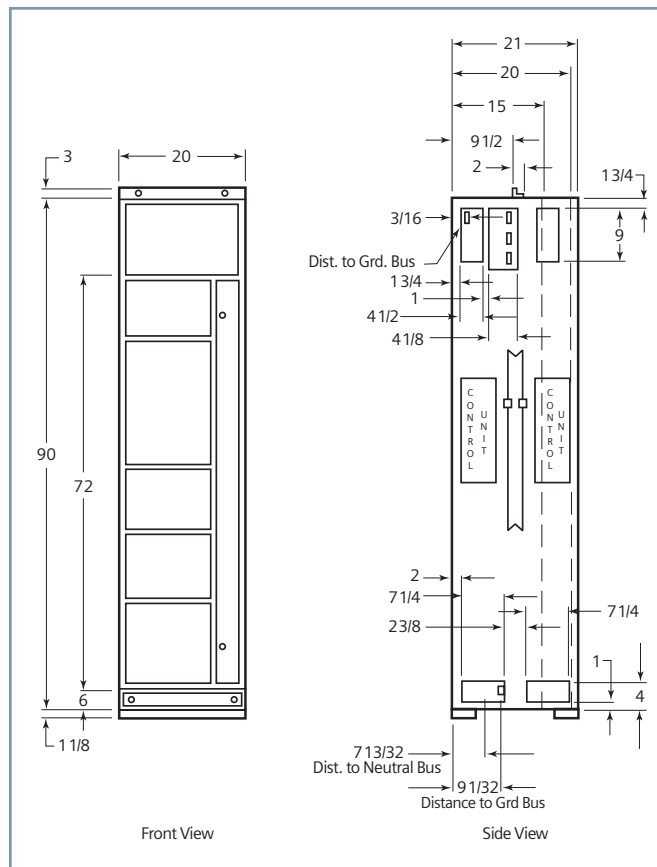

Figure 60. Mounting Dimensions

Bus Mounting Dimensions

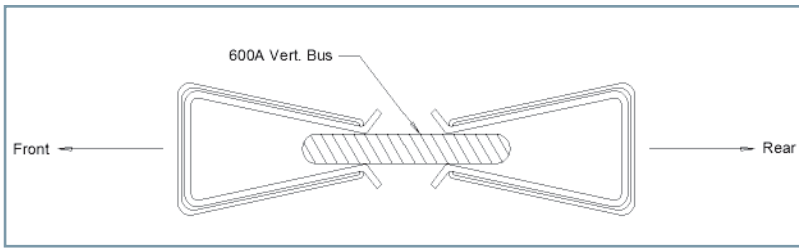

Figure 61. Stab-On Connection

Bus Drawing

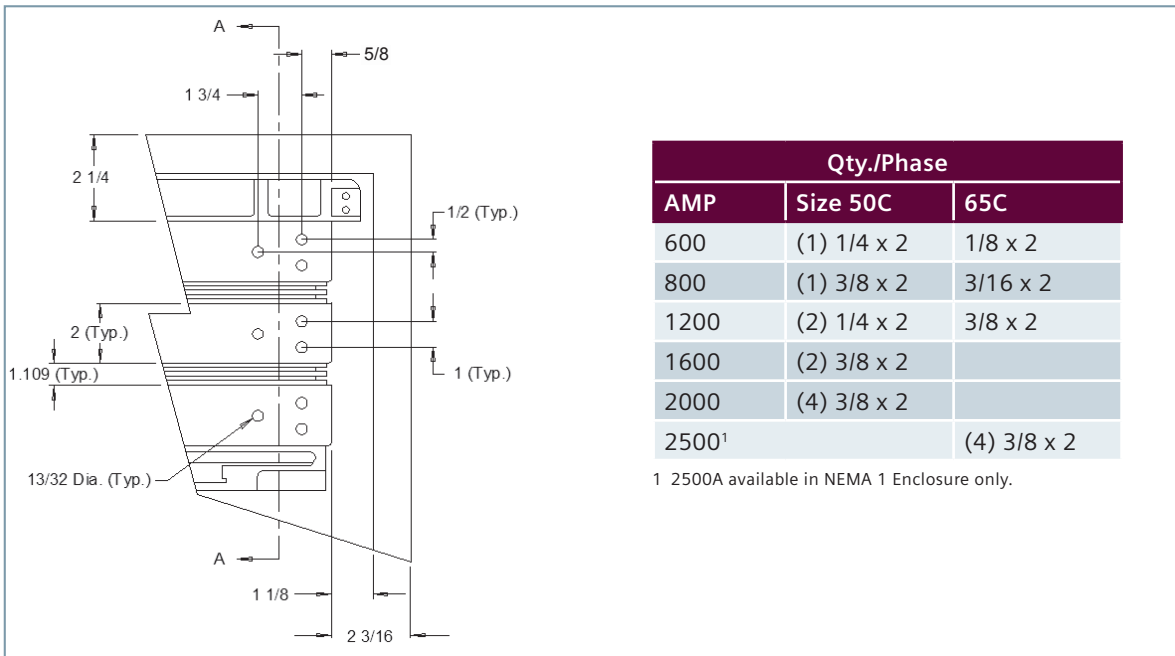

Figure 62.

Mounting of Single and Double Bus Bars

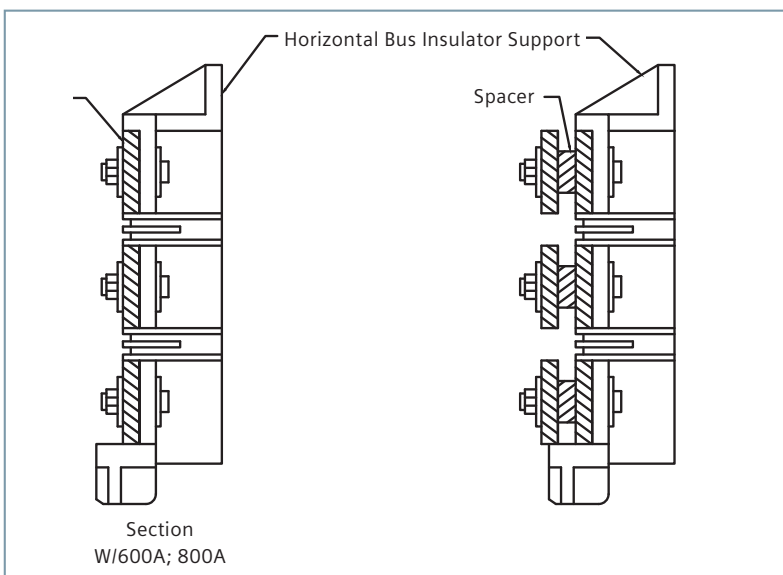

Figure 63. Section View of Single and Double Bus Bars

All dimensions are shown in inches unless otherwise specified.

Vertical Bus Dimensions and Availability

Vertical Bus		Available Structures			
Amp Rating	Size	15	20	20 Back-to-Back	24
300	3/8 x 3/4	X	X	—	X
600	3/8 x 1 1/2	X	X	X	X
800	3/8 x 1 1/2	X	X	X	X

Bus Bar Phase

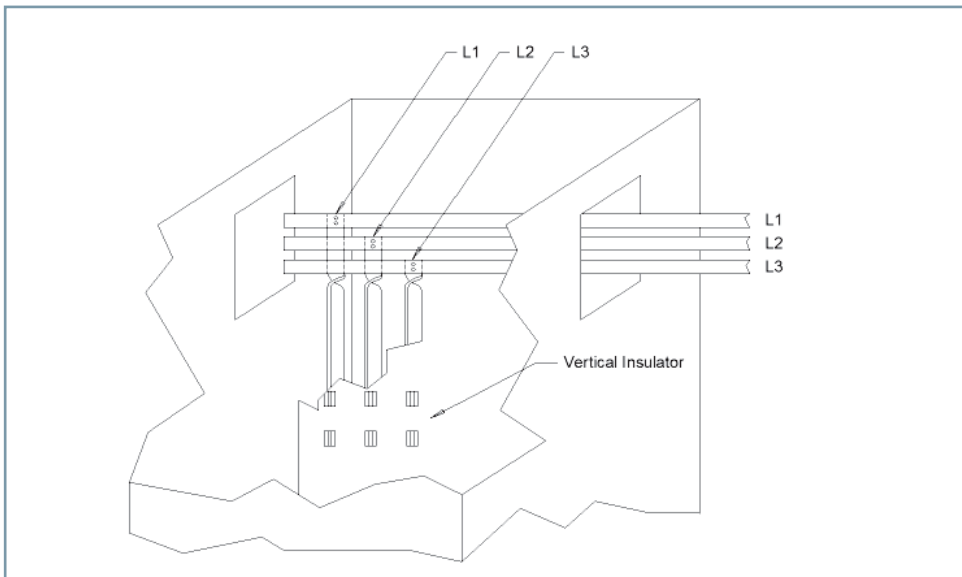

Figure 64. Front View of Bus Bar

Horizontal Bus Link

For joining two sections in the field.



Front View

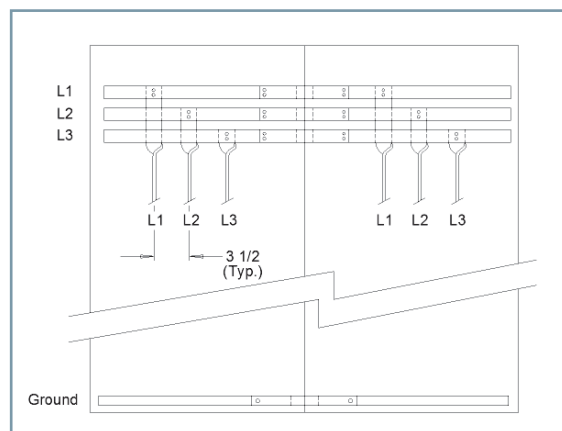

Figure 65. Front View Horizontal Bus Link

All dimensions are shown in inches unless otherwise specified.

Wireway Dimensions

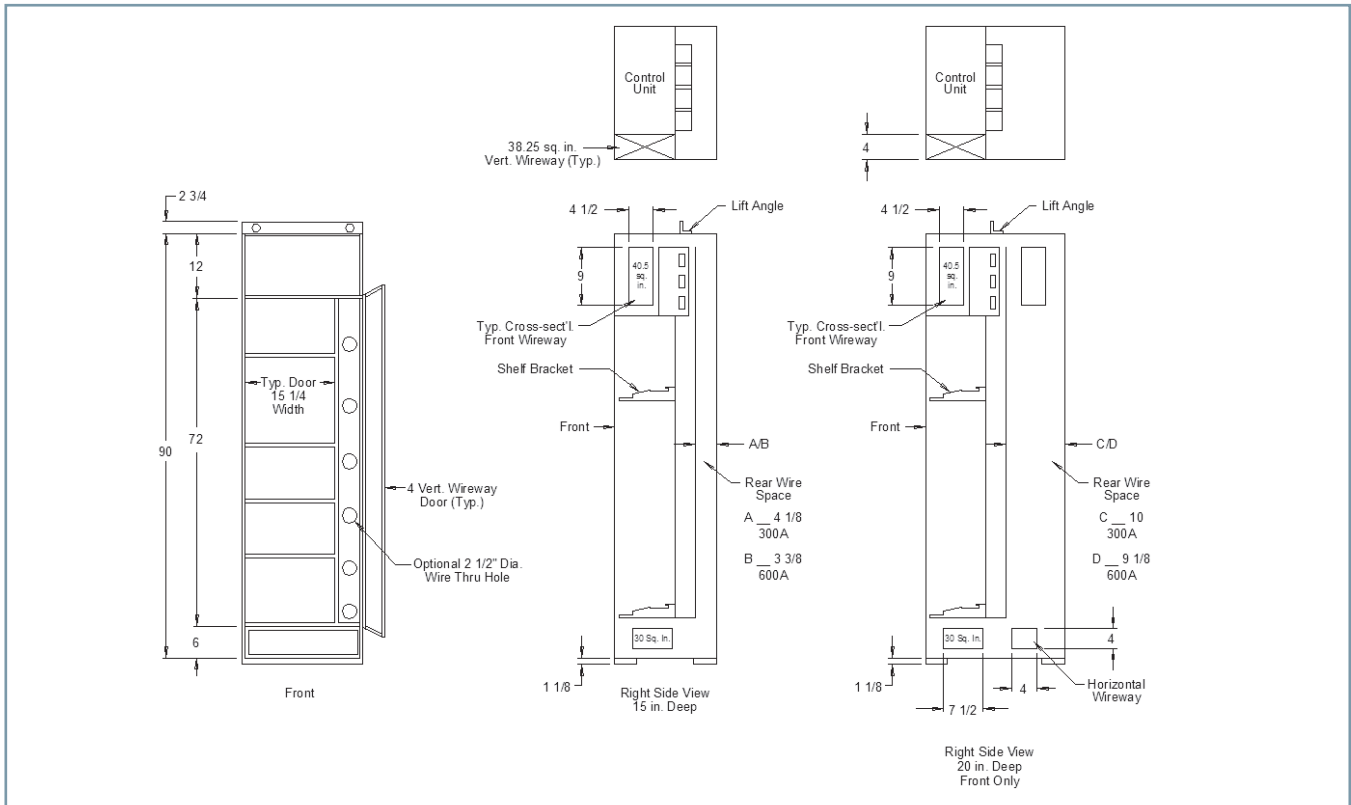

Figure 66. Front and Right Side Views of Wireway Drawings

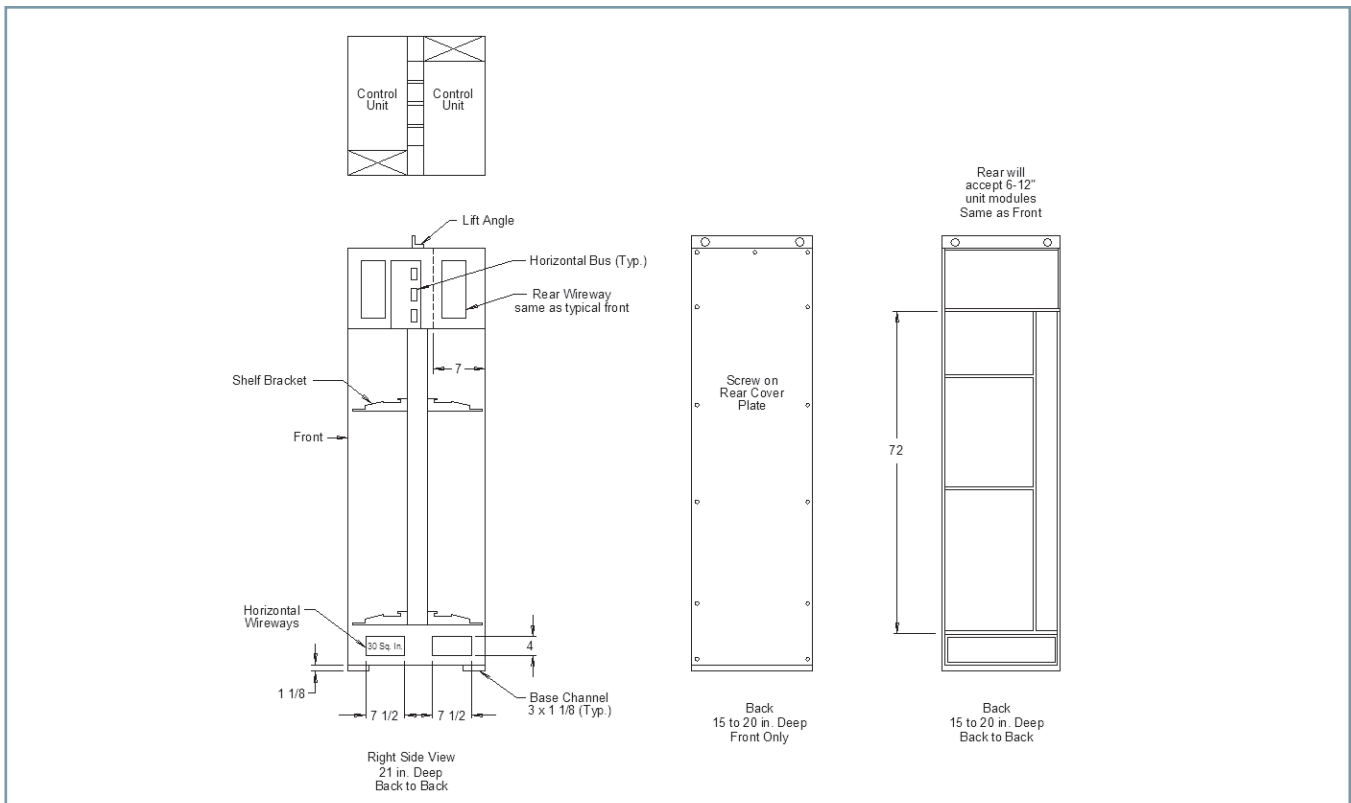

Figure 67. Back and Right Side Views of Wireway Drawings

All dimensions are shown in inches unless otherwise specified.

Blank Section

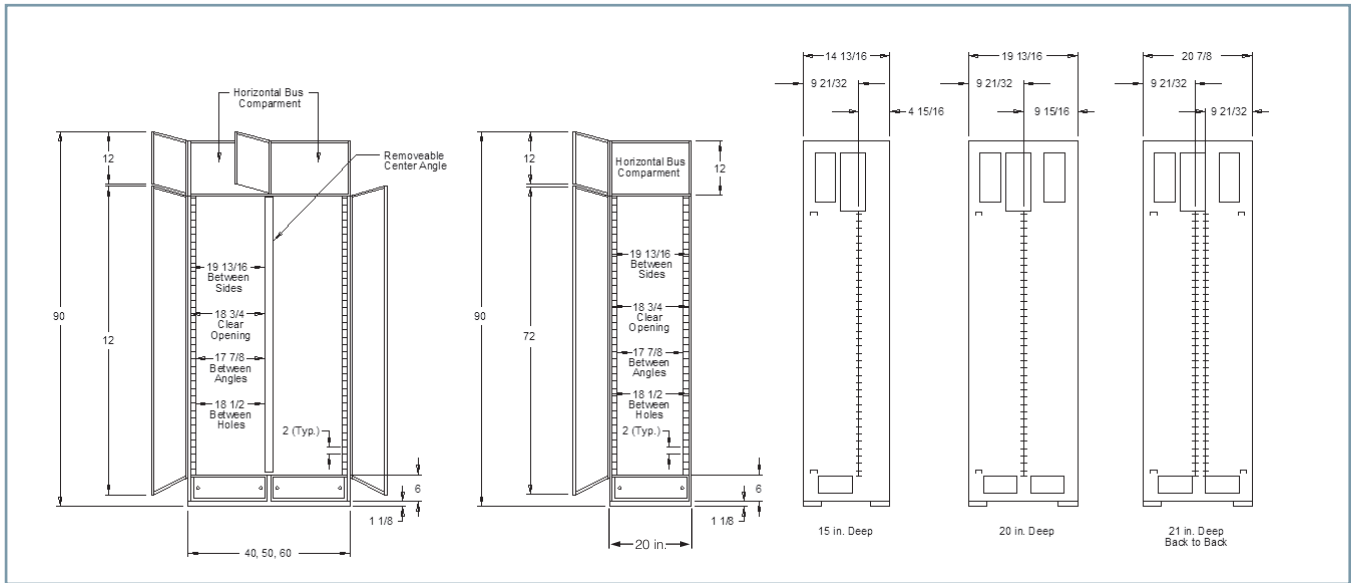

Figure 68. Dimensions of Blank Sections

Plug-in Unit

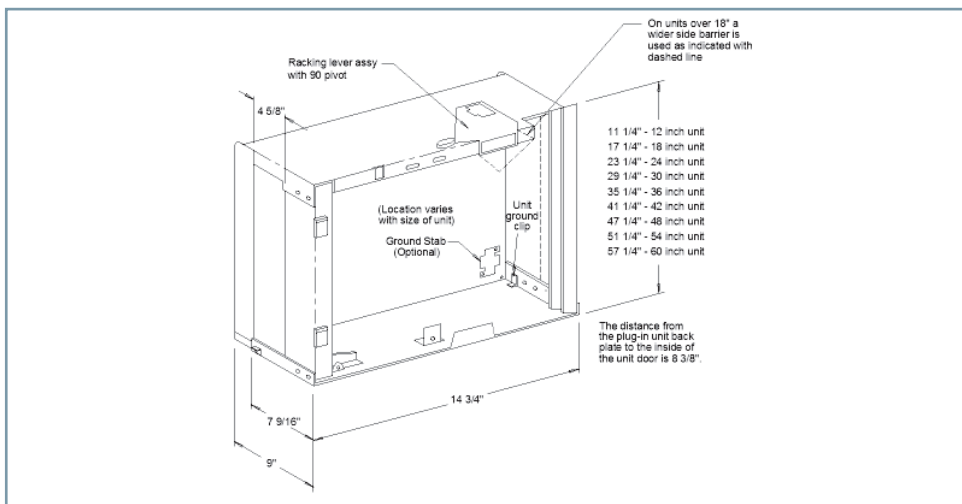

Figure 69. Isometric View of Plug-in Unit with Dimensions

Fixed Mounting Panel Dimensions

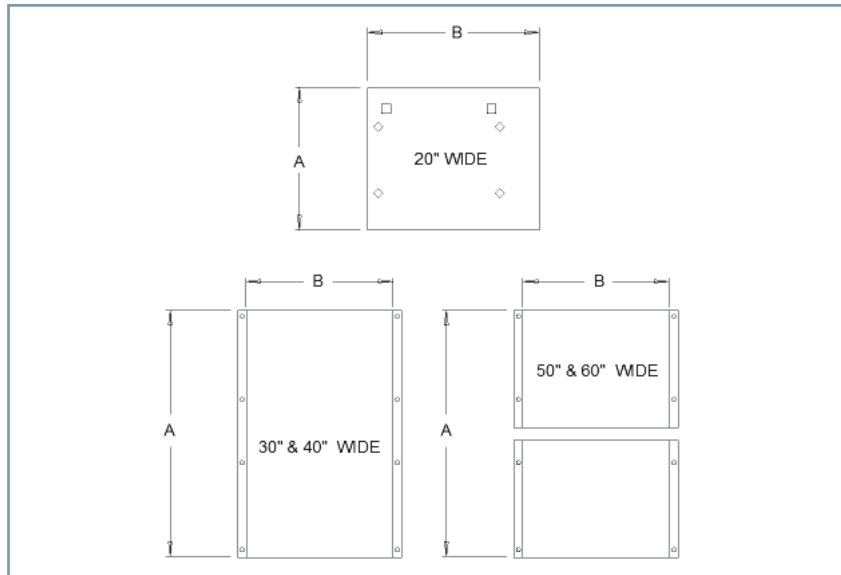

Figure 70. Fixed Mounting Panel Dimensions

Unit Space	20" A	W B	30" A	W B	40" A	W B	50" A	W B	60" A	W B
12	9	17 7/8								
18	15	17 7/8								
24	21	17 7/8								
30	27	17 7/8								
36	33	17 7/8	33	27 1/2						
42	39	17 7/8								
48	45	17 7/8								
54	51	17 7/8								
60	57	17 7/8								
66	63	17 7/8								
72	69	17 7/8	70	27 1/2	70	37 1/2	70	47 1/2	70	57 1/2

Conduit Entry and Transformer Mounting

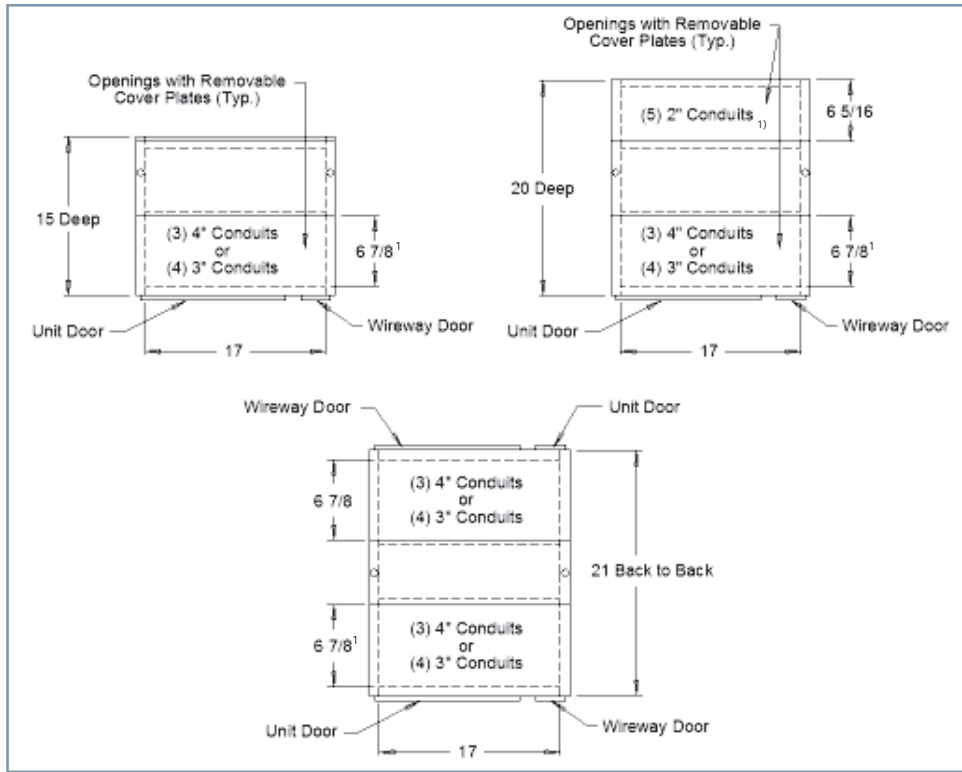

Figure 71. Top Conduit Entry for 15" and 20" Deep, and Back-to-Back

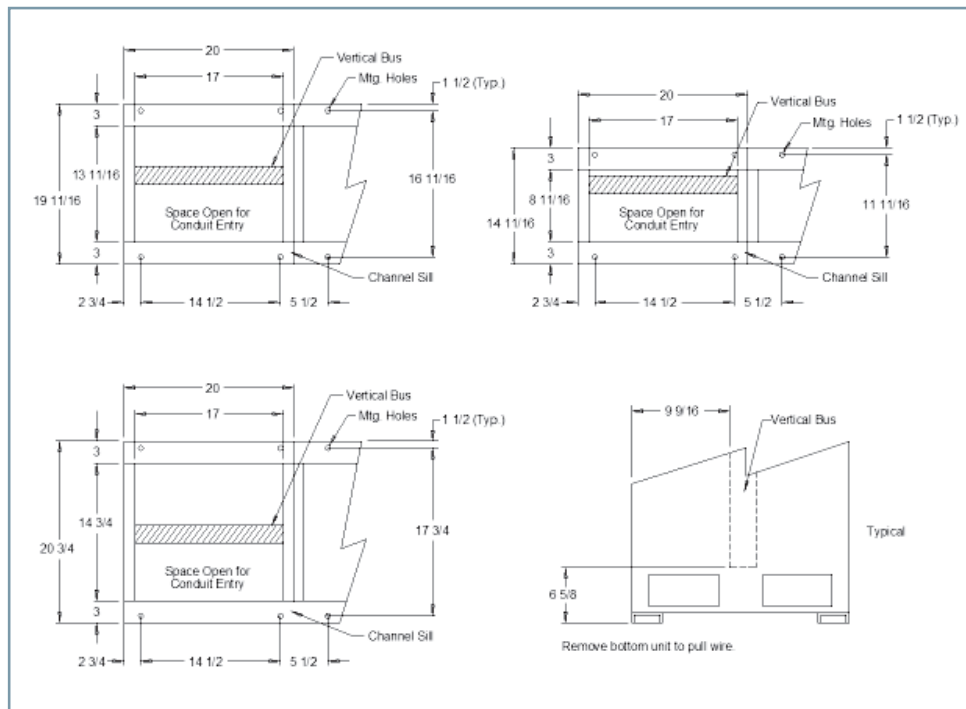

Figure 72. Bottom Conduit Entry for 15" and 20" Deep and Back-to-Back

Notes:

1. All dimensions given in inches.
2. Vertical bus is 10 5/8" from bottom of base.
3. Bottom ground bus is 7/8" from bottom of base.
4. Drawings not for construction.
For construction, obtain certified drawings from the factory

1 Front, top, conduit space for 2000A and 2500A horizontal bus or for insulated horizontal bus is 4 1/8"

Conduit Entry and Transformer Mounting

Wireway Auto Transformer Mounting and Bottom Conduit Entry Restrictions

Size 2-4
Reduced Voltage
Auto Transformers

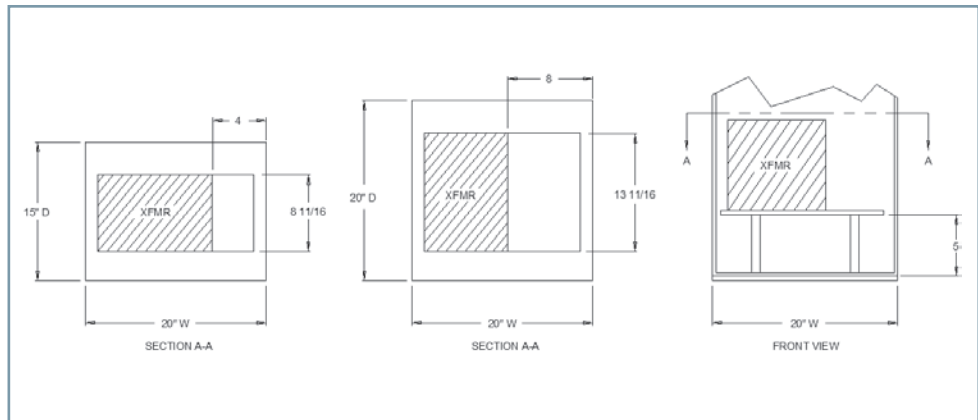

Figure 73. Size 2-4 Reduced Voltage Auto Transformers

Size 5-6
Reduced Voltage
Auto Transformers

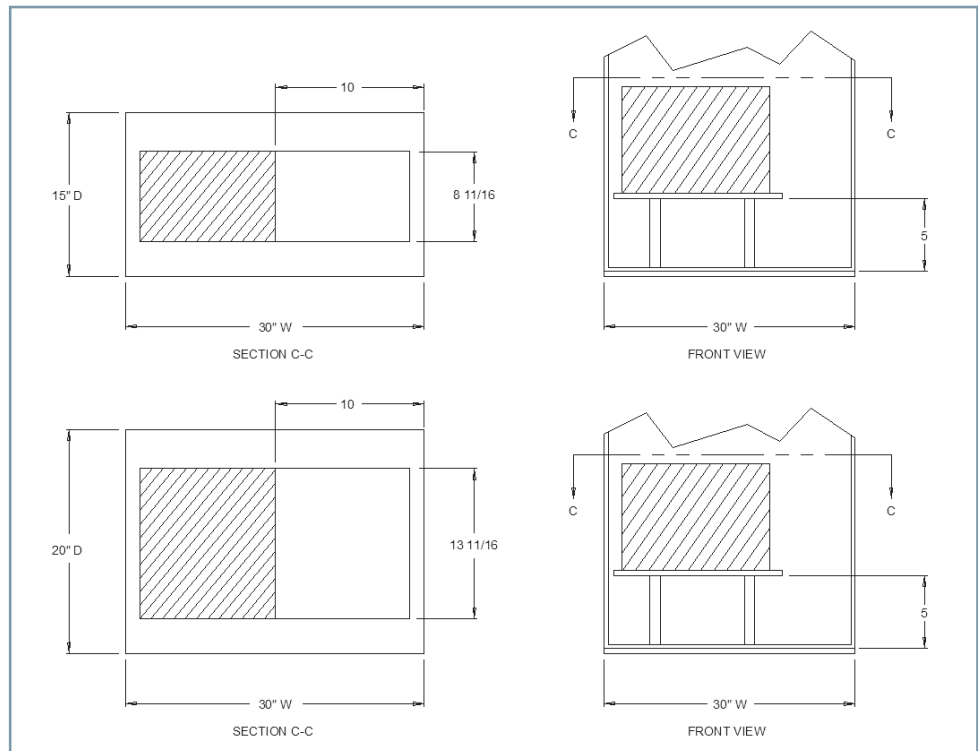

Figure 74. Size 5-6 Reduced Voltage Auto Transformers

Notes:

1. All dimensions given in inches.
2. Bottom mounted transformers will reduce conduit entry space.
3. Drawings not for construction.
For construction, obtain certified drawings from the factory.

Conduit Entry and Transformer Mounting

Lighting Transformer Mounting and Conduit Entry Restrictions

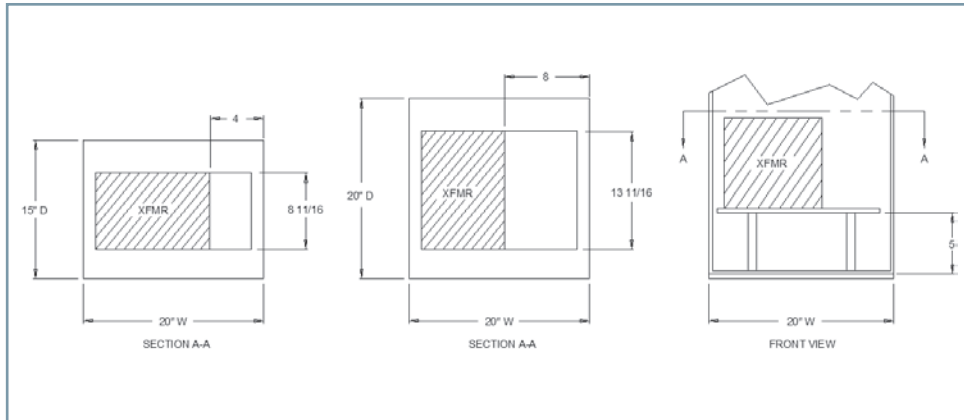

1-5 KVA Single Phase

Figure 75. 1-5 KVA Single Phase

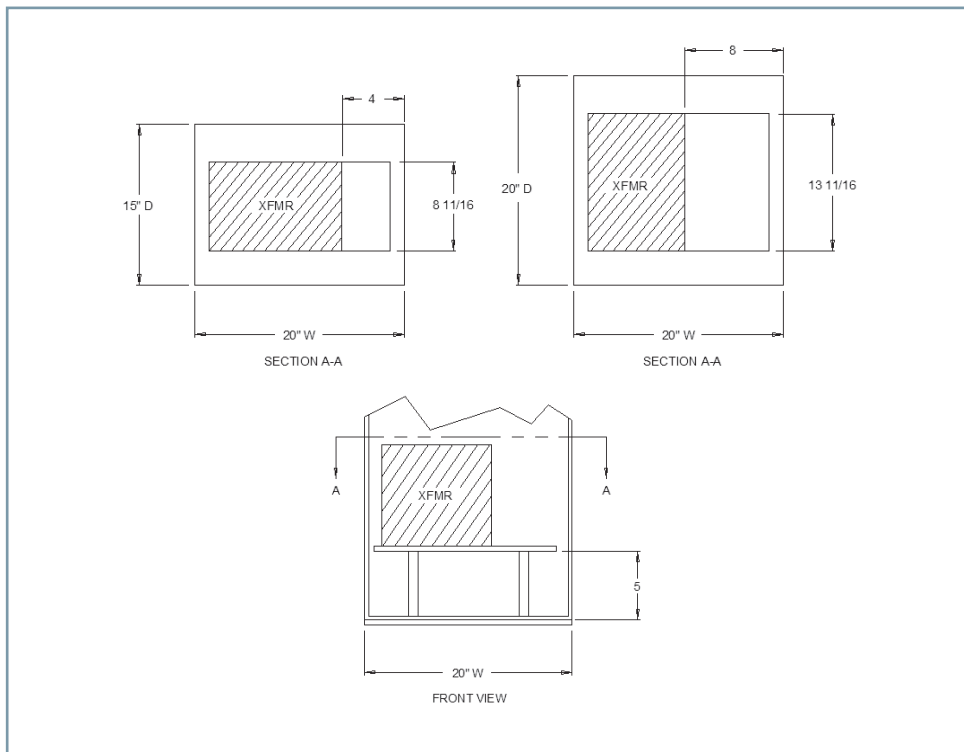

7 1/2 KVA Single Phase

Figure 76. 7 1/2 KVA Single Phase

Notes:

1. All dimensions given in inches.
2. Bottom mounted transformers will reduce conduit entry space.
3. Drawings not for construction.
For construction, obtain certified drawings from the factory.
4. Conduit entry is not recommended below 20-45 KVA single phase and all 3 phase lighting transformers.

Conduit Entry and Transformer Mounting

Lighting Transformer Mounting and Conduit Entry Restrictions

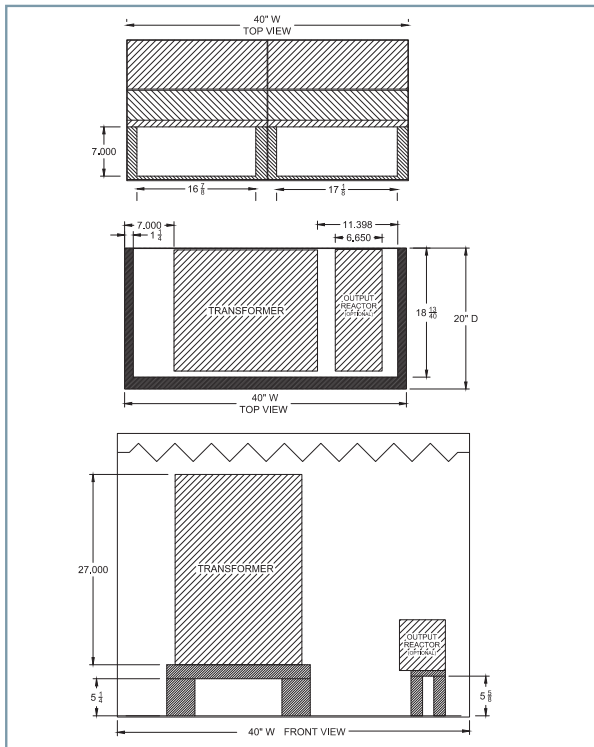

Figure 77. 40" Wide, 18 Pulse

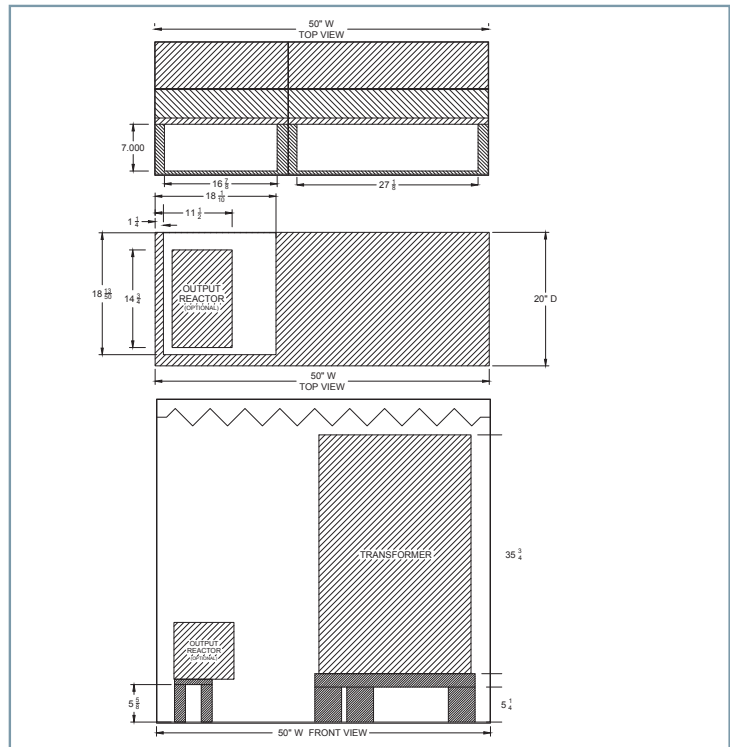

Figure 78. 50" Wide, 18 Pulse

NEMA 3R Structure Dimensions

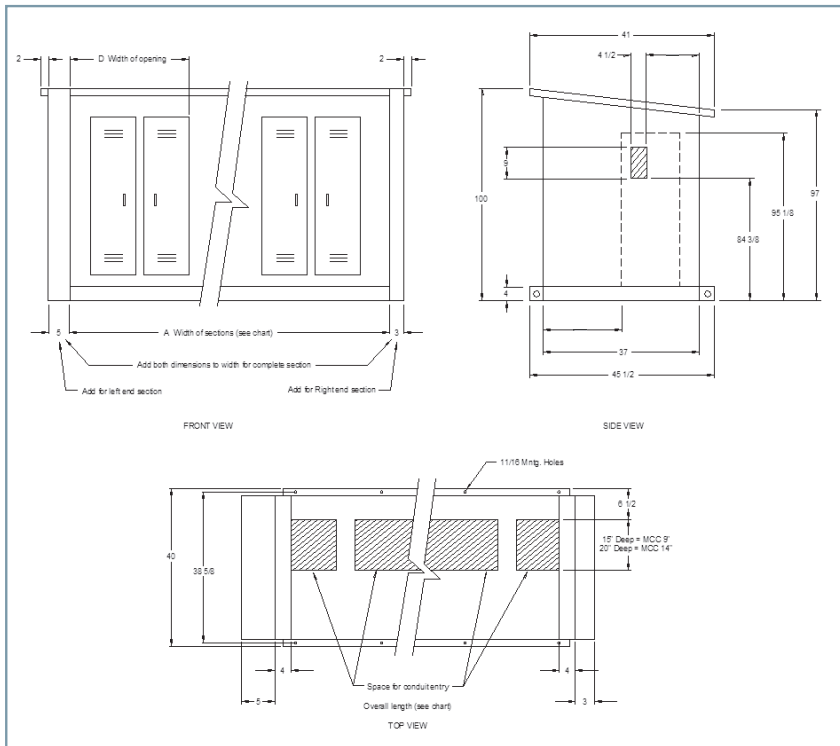

Figure 79. NEMA 3R Structure

A	D	Remarks
40	36	(2) 20" Sections
50	46	(1) 20" & (1) 30" Section
60	56	(3) 20" or (2) 30" Sections
80	(2) 36	(4) 20" Sections

Notes:

1. All dimensions given in inches.
2. Shaded areas indicate conduit entries.
3. Drawings not for construction. For construction, obtain certified drawings from the factory
4. Not available for back-to-back structures.
5. For Seismically qualified MCCs, always use conduit entry for 15" deep.

Conduit Entry and Transformer Mounting

Duplex Structure Floor Plan and Clearance Dimensions

Left-Handed "Structure" Width	Right-Handed "Structure" Width	Vertical Support (Mounting Angle Location)	Panel Orientation	A	B	C	D	E	F	G	H	J
				Structure Depth	Panel Surface to inside of Door Brace	Panel Surface to inside of Door	Left-Hand Door Opening Clearance	Right-Hand Door Opening Clearance	Total Opening Available (Door Brace Removed)	Duplex Width	Conduit Entry Space	Conduit Entry Space
—	—	Standard	Standard	15	6.35	8.34	—	—	—	—	—	—
—	—	Standard	Standard	20	6.35	8.34	—	—	—	—	—	—
—	—	Standard	Inverted	15	8.85	10.93	—	—	—	—	—	—
—	—	Standard	Inverted	20	8.25	10.93	—	—	—	—	—	—
—	—	Recessed	Standard	15	9.25	11.20	—	—	—	—	—	—
—	—	Recessed	Standard	20	14.25	16.20	—	—	—	—	—	—
—	—	Recessed	Inverted	15	11.77	13.70	—	—	—	—	—	—
—	—	Recessed	Inverted	20	16.75	18.70	—	—	—	—	—	—
20	—	—	—	—	—	—	18	18	38.88	40	17	17
30	—	—	—	—	—	—	18	18	48.88	50	17	27
30	—	—	—	—	—	—	28	28	58.88	60	17	27

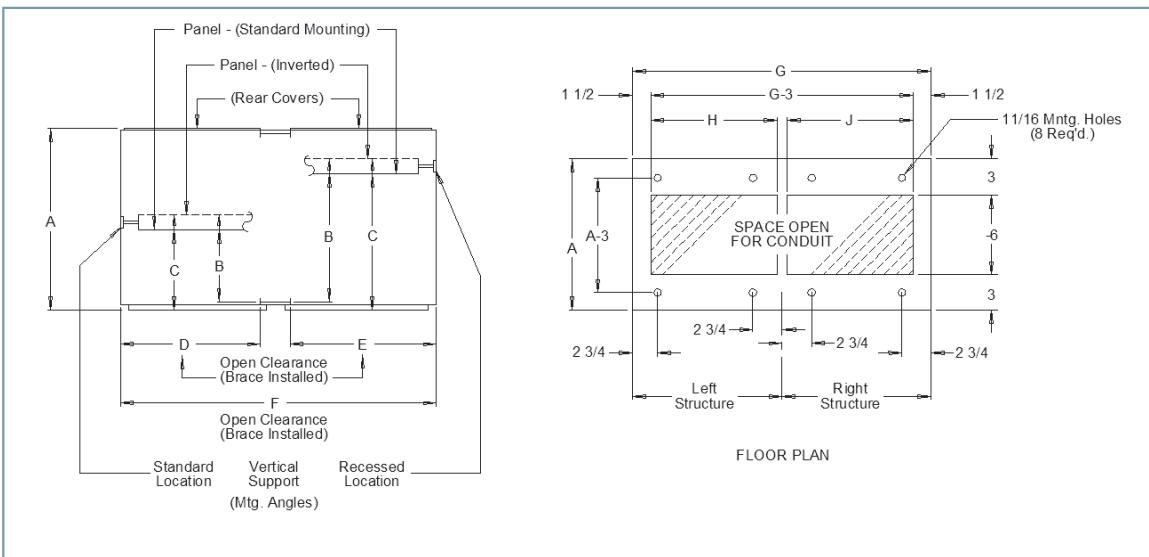

Figure 80. Duplex Structure Floor Plan

Motor Circuit Protector (MCP) Selection

Recommended MCP Type Selection: 30/60Hz Squirrel Cage Motors
MCP Selection

Unit Space	200V 60Hz			208V 60Hz			230V 60Hz			380V 50Hz			415V 50Hz			460V 60Hz			575V 60Hz			
HP	Starter Size	FLA	MCP	Starter Size	FLA	MCP	Starter Size	FLA	MCP	Starter Size	FLA	MCP	Starter Size	FLA	MCP	Starter Size	FLA	MCP	Starter Size	FLA	MCP	HP
1/2	0	2.5	5	0	2.4	5	0	2.2	5	0	1.3	3	0	0.81	2	0	1.1	3	0	0.9	2	1/2
3/4		3.7	10		3.5	10		3.2	10		1.8	5		1.21	3		1.6	5		1.3	3	3/4
1		4.8	10		4.6	10		4.2	10		2.3	5		2	5		2.1	5		1.7	5	1
1 1/2		6.9	25		6.6	25		6	25		3.3	10		3.3	10		3	10		2.4	5	1 1/2
2		7.8	30		7.5	30		6.8	25		4.3	10		3.5	10		3.4	10		2.7	5	2
3		11.0	40		10.6	40		9.6	30		6.1	25		5	25		4.8	10		3.9	10	3
5	1	17.5	50	1	16.7	50	1	15.2	40	1	9.7	30	1	7.5	30	1	7.6	30	1	6.1	25	5
7 1/2		25.3	50		24.2	50		22	50		14	40		11.0	40		11.0	40		9.0	30	7 1/2
10	2	32.2	100	2	30.8	100	2	28	50	1	18	50	1	14	40	1	14	40	1	11.0	30	10
15	3	48.3	125	3	46.2	125	2	42	100	2	27	50	2	21	50	2	21	50	2	17	50	15
20		62.1	125		59.4	125		54	125		34	100		28	50		27	50		22	50	20
25		78.2	150		74.8	150		68	125		44	100		35	100		34	100		27	50	25
30	4	92	150	4	88	150	3	80	150	3	51	125	3	40	100	3	40	100	3	32	100	30
40		120	250		114	250		104	250		66	125		55	125		52	125		41	100	40
50	5	150	250	5	143	250	4	130	250	4	83	150	4	64	125	4	65	125	4	52	125	50
60		177	250		169	250		154	250		103	150		80	150		77	150		62	125	60
75		221	400		211	400		192	400		128	250		100	150		96	150		77	150	75
100	6	285	600	6	273	600	5	248	400	5	165	250	5	135	250	5	124	250	5	99	150	100
125		359	600		343	600		312	600		208	250		165	250		156	250		125	250	125
150		414	800		396	800		360	600		240	400		200	400		180	250		144	250	150
200								480	800					320	600		260	400		240	400	192
250							6		403	800	6		325	600		302	600	6	242	400	250	
300									532	800			385	800		361	600		289	600	300	
350																414	800		336	600	350	
400																477	800		382	800	400	

FLA per NEC 2014 table 430.250. MCP size meets NEC requirements per article 430.110 115% FLA min. continuous amps.

MCP trip ranges are selected to meet maximum settings per NEC table 430.52 and exception C, Art. 430.52. MSCP's are factory set at minimum and can be set to a maximum of 1700% of motor FLA per NEC 430.52 for energy efficient motors.

Above ratings will not exceed maximum size allowed to protect heater coil for energy efficient motor FLAs. Maximum ratings shown on heater coil selection charts are not to be exceeded. Do not use this chart for part winding starters. Use thermal magnetic breaker or fuse for short circuit protection.

Instantaneous Trip (Motor Circuit Protectors)

Siemens Sentron ETI Motor Circuit Protector Instantaneous Trip Breakers:
Recommended Settings

Max Settings

HP	230V		460V		575V	
	A	Set	A	Set	A	Set
¼	3	1	1	3	2	2
⅓	3	2	2	1	2	2
½	5	2	3	1	2	2
¾	10	1	5	1	3	2
1	10	2	5	2	5	1
1 ½	25	1	10	1	5	2
2	25	2	10	1	5	2
3	30	1	10	2	10	2
5	40	2	30	1	25	1
7 ½	50	1	40	1	30	1
10	50	2	40	2	30	2
15	100	2	50	1	50	1
20	125	1	50	2	50	1
25	125	2	100	1	50	2
30	150	3	100	1	100	1
40	250	2	125	1	100	2
50	250	3	125	2	125	1
60	250	5	150	3	125	2
75	400	2	150	5	150	3
100	400	5	250	3	150	5
125	600	3	250	3	250	3
150	600	4	250	7	250	4
200	800	4	400	4	400	2
250	—	—	600	3	400	4
300	—	—	600	4	600	2
350	—	—	800	2	600	4
400	—	—	800	4	800	2

A = Breaker Ampere Rating

For maximum protection the trip position should be set as low as possible. Turn the adjustment screw counter-clockwise to successively lower positions until the breaker trips on motor starting. After this position is determined, turn the adjustment screw clockwise to the next higher setting for normal operation. The adjustment screw is infinitely adjustable for customer convenience. If the breaker does not trip at the lowest setting leave the indicator at this setting. The instantaneous breaker is factory set at the LOW position.



WARNING

Fire, electric shock, or explosion hazard. Can cause death, serious injury or property damage.

To provide continued protection against risk of fire or electric shock, examine and if damaged replace current-carrying parts and other components of combination controller. Tripping (opening) of branch-circuit protection device may be an indication that fault current has been interrupted. If overload relay current elements burn out, replace complete overload relay. To maintain overcurrent, short circuit and ground fault protection, follow manufacturer's instructions for selecting current elements and setting instantaneous trip circuit breaker.

	Trip Setting Positions							
	LOW	2	3	4	5	6	7	HI
1	2.6	4.5	6	7.5	—	—	—	9
2	7	11	15	19	—	—	—	22
3	10	17	23	30	—	—	—	35
5	16	26	36	46	—	—	—	54
10	30	50	70	85	—	—	—	100
25	55	90	125	155	—	—	—	180
30	80	135	185	235	—	—	—	270
40	115	185	255	325	—	—	—	375
50	180	300	410	520	—	—	—	600
100	315	540	740	890	—	—	—	1000
125	500	720	920	1000	—	—	—	1250
150	800	900	1000	1100	1200	1300	1400	1500
250	1100	1300	1500	1700	1900	2100	2300	2500
400	2000	2290	2570	2860	3140	3430	3710	4000
600	3000	3430	3800	4290	4710	5140	5570	6000
800	4000	4570	5740	5810	7240	6850	7240	8000

Recommended Thermal Magnetic Breaker Type Selection 3 Phase 60Hz Squirrel Cage Motors

Unit Space	200V 60Hz			208V 60Hz			230V 60Hz			380V 50Hz			415V 50Hz			460V 60Hz			575V 60Hz			Unit Space							
HP	Starter Size	FLA	CB Trip	Starter Size	FLA	CB Trip	Starter Size	FLA	CB Trip	Starter Size	FLA	CB Trip	Starter Size	FLA	CB Trip	Starter Size	FLA	CB Trip	Starter Size	FLA	CB Trip	HP							
1/2	0	2.5	15	0	2.4	15	0	2.2	15	0	1.3	15	0	0.81	15	0	1.1	15	0	0.9	15	1/2							
3/4		3.7	15		3.5	15		3.2	15		1.8	15		1.21	15		1.6	15		1.3	15	3/4							
1		4.8	15		4.6	15		4.2	15		2.3	15		2	15		2.1	15		1.7	15	1							
1 1/2		6.9	15		6.6	15		6	15		3.3	15		3	15		3	15		2.4	15	1 1/2							
2		7.8	15		7.5	15		6.8	15		4.3	15		3.5	15		3.4	15		2.7	15	2							
3		11.0	20		10.6	20		9.6	20		6.1	15		5	15		4.8	15		3.9	15	3							
5	1	17.5	30	1	16.7	30	1	15.2	25	1	9.7	20	1	7.5	15	1	7.6	15	1	6.1	15	5							
7 1/2		25.3	45		24.2	40		22	40		14	25		11.0	20		11.0	20		9.0	15	7 1/2							
10	2	32.2	60	2	30.8	50	2	28	45	1	18	30	1	14	25	1	14	25	1	11.0	20	10							
15	3	48.3	80	3	46.2	80	2	42	70	2	27	45	2	21	35	2	21	35	2	17	30	15							
20		62.1	100		59.4	100		54	90		2	34		60	2		28	50		2	27	45	2	22	40	20			
25		78.2	150		74.8	125		68	110		4	44		80	3		35	60		3	34	60	3	34	60	3	27	50	25
30	4	92	150	4	88	150	3	80	150	3	51	90	3	40	70	3	40	70	3	32	60	30							
40		120	200		114	200		104	175		3	66		110	3		66	110		3	55	90	3	52	90	3	41	70	40
50	5	150	250	5	143	250	4	130	225	4	83	150	4	64	110	4	65	110	4	52	90	50							
60		177	300		169	300		154	250		4	103		175	4		80	150		4	77	125	4	77	125	4	62	100	60
75		221	400		211	350		192	350		4	128		225	4		100	175		4	96	175	4	96	175	4	77	125	75
100	6	285	500	6	273	450	5	248	400	5	165	300	5	135	225	5	124	200	5	99	175	100							
125		359	600		343	600		312	500		5	208		350	5		165	300		5	165	300	5	156	250	5	125	200	125
150	6	414	700	6	396	700	6	360	600	6	240	400	6	200	350	6	180	300	6	144	250	150							
200		6	700		6	700		6	800		6	600		6	600		6	450		6	400	6	500	6	350	600	700	200	
250																												6	700
300	6	700	6	700	6	800	6	600	6	600	6	450	6	400	6	500	6	350	600	700	300								
350																					6	700	6	700	6	800	6	600	6
400	6	700	6	700	6	800	6	600	6	600	6	450	6	400	6	500	6	350	600	700									
																					6	700	6	700	6	800	6	600	6

Circuit breaker trip ratings are selected in accordance with NEC 2014 article 430.52 and table 430.52 assuming motors with locked rotor KVA Code B thru E. Lower trip ratings may be required for motors with Code A. FLA per NEC 2014 table 430.250. Do not use to size heater coils. Use motor NP data.

Maximum ratings shown on Heater Coil selection charts are not to be exceeded. Special applications on motor may require different rating, refer to proper section of NEC to size.

Do not use this chart for part winding starters - Maximum breaker size to be limited to 200% FLA or less, 150% for FLA greater than 100A.

Fuse Selection

UL Standard Fuse Classifications							
	K1	K5	K9	RK1	RK5	J	L
Amp Rating Range	0-600	0-600	0-600	0-600	0-600	0-600	601-6000
Interrupting Rating RMS Amps	200,000	200,000	200,000	200,000	200,000	200,000	200,000
Voltage	250 or 600	250 or 600	250 or 600	250 or 600	250 or 600	600	600
Current Limiting Characteristics	High	Moderate	Fair	High	Moderate	High	High
Dual Element Time Delay	No	Yes	Yes	No	Yes	No	Yes ³
Generic Names	Current Limiting ¹	Current Limiting Time Delay ¹	Current Limiting Time Delay ¹	Current Limiting	Current Limiting Time Delay	Current Limiting	Current Limiting
Rejection Type	No	No	No	Yes	Yes	Inherent	Inherent
Manufacturer Designations	Bussman KTN Bussman KTS	Bussman FRN Bussman FRS		Bussman LPN-RK Bussman KTS-R Mersen A2D Mersen A6D	Bussman LPN-RK Bussman KTS-R Mersen A2D Mersen A6D	Bussman JKS Mersen A4J	Bussman KTU Mersen A4Bt

1 UL does not permit fuses to be marked "current limiting" due to lack of rejection feature.

2 Class J smaller the NEC Code specifications; Class L requires bolt-on fuse blocks. Inherent rejection feature of unique fuse dimensions allows UL marking of "current limiting" features.

3 Class "L" fuses may be marked "Time Delay" although UL does not investigate Time Delay characteristics of such fuses.

Fuse Selection 3 Phase 60Hz Squirrel Cage Motors

Fuse sizes are selected in accordance with NEC 2014 article 430.52 & 57 and table 430.52.

HP	200V 60Hz				208V 60Hz				230V 60Hz				380V 50Hz			
	Starter Size	FLA	Time Delay	Non Delay	Starter Size	FLA	Time Delay	Non Delay	Starter Size	FLA	Time Delay	Non Delay	Starter Size	FLA	Time Delay	Non Delay.
1/2	0	2.5	4	5	0	2.4	4	5	0	2.2	3.5	4.5	0	1.3	2	2.8
3/4		3.7	5.6	8		3.5	5.6	7		3.2	5	7		1.8	2.8	3.5
1		4.8	8	10		4.6	7	10		4.2	7	9		2.3	3.5	5
1 1/2		6.9	10	15		6.6	10	15		6	9	12		3.3	5.6	7
2		7.8	12	17.5		7.5	12	15		6.8	10	15		4.3	7	9
3		11.0	17.5	25		10.6	15	20		9.6	15	20		6.1	10	15
5	1	17.5	30	40	1	16.7	25	30	1	15.2	25	30	1	9.7	15	20
7 1/2		25.3	40	50		24.2	40	50		22	35	45		14	25	30
10	2	32.2	45	60	2	30.8	45	60	2	28	45	60	1	18	30	30
15	3	48.3	80	100	3	46.2	70	90	3	42	60	90	2	27	40	60
20		62.1	100	125		59.4	90	110		54	80	100		34	60	70
25		78.2	125	175		74.8	110	150		68	100	125		44	70	90
30	4	92	150	200	4	88	150	175	4	80	125	175	3	51	80	100
40		120	200	225		114	175	225		104	175	200		66	100	125
50	5	150	225	300	5	143	225	300	5	130	200	250	4	83	150	175
60		177	300	400		169	300	350		154	250	350		103	150	200
75		221	350	400		211	350	400		192	300	400		128	200	200
100	6	285	450	600	6	273	450	600	6	248	400	400	5	165	250	350
125		359	600	600		343	600	600		312	500	600		208	300	400
150		414	650	800		396	650	800		360	600	700		240	400	400
200										480	800	800				
250													6	403	600	800
300														532	800	800
350																
400																

Fuse sizes are selected in accordance with NEC 2014 article 430.52 & 57 and table 430.52.

415V 50Hz				460V 60Hz				575V 60Hz				HP
Starter Size	FLA	Time Delay	Non Delay	Starter Size	FLA	Time Delay	Non Delay	Starter Size	FLA	Time Delay	Non Delay	
0	0.81	1.25	1.8	0	1.1	1.8	2.25	0	0.9	1.4	1.8	1/2
	1.21	2	2.8		1.6	2.5	3.2		1.3	2	2.8	3/4
	2	3	4		2.1	3.2	4.5		1.7	2.8	3.5	1
	2.5	4	5.6		3	4.5	6		2.4	4	5	1 1/2
	3.5	5	7		3.4	5	7		2.7	4	5.6	2
	5	8	12		4.8	8	10		3.9	6	8	3
	7.5	12	15		7.6	12	15		6.1	9	12	5
1	11.0	17.5	25	1	11.0	17.5	25	1	9.0	15	20	7 1/2
	14	25	30		14	20	30		11.0	17.5	25	10
2	21	35	45	2	21	35	40	2	17	25	35	15
	28	45	60		27	40	60		22	35	45	20
	35	60	60		34	50	60		27	40	60	25
3	40	60	80	3	40	60	80	3	32	50	70	30
	55	80	100		52	80	100		41	60	80	40
	64	100	125		65	100	125		52	80	100	50
4	80	125	175	4	77	125	175	4	62	100	125	60
	100	150	200		96	150	200		77	125	175	75
	135	200	300		124	200	225		99	150	200	100
5	165	250	350	5	156	250	350	5	125	200	250	125
	200	300	400		180	300	400		144	225	300	150
	260	400	600		240	400	400		192	300	400	200
6	325	500	600	6	302	450	600	6	242	400	500	250
	385	600	800		361	600	700		289	450	600	300
					414	650	800		336	500	600	350
					477	800	800		382	600	700	400

Size fuses, time delay or non-time delay, in accordance with the NEC permitted fuse size as noted below:

Starter Size	Maximum Fuse Size		
	Class R	Class J	Class L
0	30	60	-
1	60	120	-
2	100	200	-
3	200	400	-
4	200	400	-
5	400	800	-
6	600	800	800

If the calculated rating is between standard sizes, the next larger size may be used. Fuse size may not exceed switch size.

Minimum switch size per NEC 430.110 must be 115% of FLA of motor. Do not use this chart for part winding motors. Size as follows: maximum fuse size

limited to 150% FLA for dual element fuses and 200% for non-delay type fuses.

Heater Tables

E "Standard Trip" Heater Elements for Ambient Temp. Comp. Bimetal Relays

Full Load Motor Amps		Heater Code No.	Max. Rat. of Prot. Device*	Full Load Motor Amps		Heater CodeNo.	Max. Rat. of Prot. Device*
Min	Max			Min	Max		
Size 0 & 1				Size 1 3/4			
0.67	0.72	E14	1	2.27	2.54	E34	3
0.73	0.80	E16	2	2.55	2.69	E36	5
0.73	0.80	E16	2	2.70	2.88	E37	5
2.08	2.26	E33	3	2.89	3.14	E38	5
2.27	2.54	E34	3	3.15	3.40	E39	5
2.55	2.69	E36	5	3.41	3.81	E41	5
2.70	2.88	E37	5	3.82	4.25	E42	5
2.89	3.14	E38	5	4.26	4.62	E44	7
3.15	3.40	E39	5	4.63	5.09	E46	10
3.41	3.81	E41	5	5.10	5.61	E47	10
3.82	4.26	E42	5	5.62	5.91	E48	10
4.27	4.62	E44	7	5.92	6.15	E49	10
4.63	5.09	E46	10	6.16	6.70	E50	10
5.10	5.61	E47	10	6.71	7.54	E51	10
2.08	2.26	E33	3	7.55	8.29	E52	25
2.27	2.54	E34	3	8.30	8.99	E53	25
2.55	2.69	E36	5	9.00	9.85	E54	25
2.70	2.88	E37	5	9.86	10.4	E55	25
2.89	3.14	E38	5	10.5	12.0	E56	25
3.15	3.40	E39	5	12.1	13.6	E57	25
3.41	3.81	E41	5	13.7	15.6	E60	30
3.82	4.26	E42	5	15.7	17.0	E61	30
4.27	4.62	E44	7	17.1	19.4	E62	30
4.63	5.09	E46	10	19.5	20.9	E65	30
5.10 1	5.6	E47	10	21.0	22.2	E66	40
5.62	5.91	E48	10	22.3	25.3	E67	40
5.92	6.15	E49	10	25.4	26.9	E69	40
6.16	6.70	E50	10	27.0	30.2	E70	40
6.71	7.54	E51	25	30.3	33.3	E72	40
7.55	8.29	E52	25	Size 2 & 2 1/2			
8.30	8.99	E53	25	10.5	12.0	E56	50
9.00	9.85	E54	25	12.1	13.6	E57	50
9.86	10.4	E55	25	13.7	15.6	E60	50
10.5	12.0	E56	25	15.7	17.1	E61	50
12.1	13.6	E57	25	17.2	19.4	E62	50
13.7	15.6	E60	30	19.5	20.9	E65	50
15.7	17.0	E61	30	21.0	22.2	E66	50
17.1	19.4	E62	30	22.3	25.3	E67	50
18.5	19.4	E65	30	25.4	26.9	E69	50
19.5	20.9	E65	30	27.0	30.2	E70	50
21.4	24.4	E67	40	30.3	33.3	E72	50
24.5	25.9	E69	40	33.4	35.3	E73	50
26.0	26.0	E70	40	35.4	41.5	E74	50
				41.6	45.0	E76	100
				45.1	52.3	E77	100
				52.4	55.7	E78	100

FullLoad MotorAmps		Heater CodeNo.	Max.Rat. of Prot. Device*
Min	Max		
Size 3 & 3 1/2			
30.0	33.5	E69	100
33.6	36.4	E70	100
36.5	39.6	E71	100
39.7	43.6	E73	100
43.7	46.5	E73A	100
46.6	51.6	E74	100
51.7	54.4	E76	100
54.5	58.0	E77	100
58.1	63.0	E78	100
63.1	67.7	E79	100
67.8	72.4	E80	100
72.5	80.0	E94	100
80.1	88.1	E96	150
88.2	91.5	E97	150
91.6	96.8	E98	150
96.9	99.0	E99	150
99.1	108	E101	150
Size 4			
56.9	60.9	E89	250
61.0	63.9	E91	250
64.0	67.7	E92	250
67.8	72.4	E93	250
72.5	77.7	E94	250
77.8	85.9	E96	250
86.0	91.9	E97	250
92.0	96.7	E98	250
96.8	105	E99	250
106	115	E103	250
116	130	E104	250

FullLoad MotorAmps		Heater CodeNo.	Max.Rat. of Prot. Device ¹
Min	Max		
Size 4 1/2 & 5			
88.0	98.0	E27	400
98.1	108	E28	400
109	114	E29	400
115	122	E31	400
123	130	E32	400
131	140	E33	400
141	155	E34	400
156	166	E36	400
167	177	E37	400
178	193	E38	400
194	209	E39	400
210	233	E41	400
234	248	E42	400
Size 6			
166	195	E27	600
196	217	E28	600
218	229	E29	600
230	245	E31	600
246	261	E32	600
262	281	E33	600
282	311	E34	600
312	331	E36	600
332	355	E37	600
356	387	E38	600
388	419	E39	600
420	467	E41	600
468	500	E42	600

Heaters shown in the table provide a maximum trip rating of 125% of the motor name plate amperes, which is suitable for 40°C motors. For all other motors select heaters one code number lower than specified in the table, which give a maximum trip rating of approximately 115%.

The tripping current of any heater in a 40°C ambient is 25% greater than the lower value of motor amperes shown in the table.

Starters do not provide protection from short circuits. A protective device should be provided in accordance with the NEC (CEC in Canada) and not exceed the values shown in the table.

Note: If the rating specified is not a standard size for the circuit breaker manufacturer, use the next largest size.

1 Ratings specified are for instantaneous trip circuit breakers.

Maximum current rating for thermal magnetic circuit breakers is 250% of maximum heater FLA.

Maximum current rating of fuses is:

- a. 150% of maximum heater FLA for Class R, K, or L (time delay).
- b. 250% of maximum heater FLA for Class K or L (non-time delay).
- c. 300% of maximum heater FLA for Class J (nontime delay).

If the calculated rating is between standard sizes, the next larger size may be used. Fuse size may not exceed switch size.

Wye-delta starters: If the motor name-plate shows the full load delta line current only, divide this value by 1.73 or multiply by .58 to select the proper heater rating

⚠ WARNING

Fire, electric shock, or explosion hazard. Can cause death, serious injury or property damage.

To provide continued protection against risk of fire or electric shock, examine and if damaged replace current-carrying parts and other components of combination controller. Tripping (opening) of branch-circuit protection device may be an indication that fault current has been interrupted. If overload relay current elements burn out, replace complete overload relay. To maintain overcurrent, short circuit a ground fault protection, follow manufacturer's instructions for selecting current elements and setting instantaneous trip circuit breaker.

⚠ WARNING

Hazardous voltage. Can cause death, serious personal injury, or property damage.

Automatic reset will continue to reset on two-wire control. When not desired, use three-wire control.

Do not use manual trip button when relay is set in automatic reset position.

Part Winding Starter Heater Selection

WYE – NEMA connected dual voltage motor
 or
 SPECIAL – 6 lead DELTA connected part winding motor.
 DELTA – NEMA connected dual voltage motor.

Select overload heaters from table in both starters (M1 and M2) based on ½ motor nameplate full load current.

Example:

Motor Full Load Current of 15 Amperes, Select Heaters from Table for 7.5 Amperes.
 Consult factory – Give complete motor data and application.

Bimetal Overload Relays

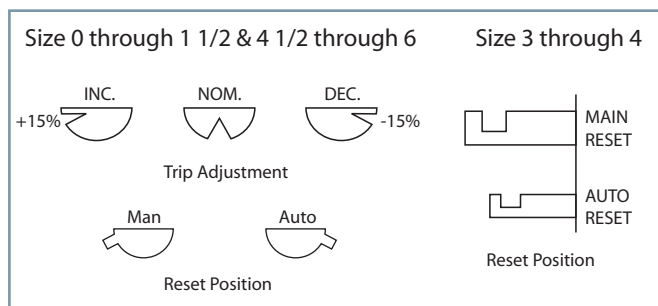

Figure 81.

⚠ WARNING

Fire, electric shock, or explosion hazard. Can cause death, serious injury or property damage.

To provide continued protection against risk of fire or electric shock, examine and if damaged replace current-carrying parts and other components of combination controller. Tripping (opening) of branch-circuit protection device may be an indication that fault current has been interrupted. If overload relay current elements burn out, replace complete overload relay. To maintain overcurrent, short circuit a ground fault protection, follow manufacturer's instructions for selecting current elements and setting instantaneous trip circuit breaker.

To maintain overcurrent, short circuit, and ground fault protection, the manufacturers instructions for selection of the current elements and setting of the instantaneous trip circuit breaker must be followed.

Operating starter sizes 4 through 6 without the heater elements installed will damage the Current Transformers.

Formulas For Obtaining Full Load Amps Of Other Motors

- 208V Full Load Amp \approx 230V current X 110%
- 2 Phase FLA \approx 0.866 X the 3 phase FLA
- 2 Phase, 3 wire current in common wire \approx 1.41 X that in the other 2 lines.
- 50 Hz, multiply 60 Hz value X 1.20
- 25 Hz, 1500 RPM., amps \approx amps of 60 Hz, 3600 RPM.
- 25 Hz 750 RPM., amps \approx amps of 60 Hz 1800 RPM.
- Service factor 1.0 \approx amps X 0.9.
- 50°–55°C motor \approx amps X 0.9.

Single Phase Motor FLA

The single phase full load amps of the same horsepower, voltage and speed vary over wide ranges. The following table conforms with table 430-248 of the NEC.

When possible the motor full load amps from the motor nameplate should always be used when selecting heater code numbers.

Single Phase		
HP	Amperes - 60 Hz	
	115V	230V
1/6	4.4	2.5
1/4	5.8	3.3
1/3	7.2	4.1
1/2	9.8	5.6
3/4	13.8	7.9
1	16.	9.2
1 1/2	20.	11.5
2	24.	13.8
3	34.	19.6
5	56.	32.2
7 1/2	80.	46.
10	100.	57.5

Approximate AC Motor Amps

Use only When Motor Full Load Current is Not Known

Motor Amps will vary depending on the type and manufacture of the motor. These average values, usually for T frame motors with service factor of 1.15 are to be used only as a guide. The formulas on the previous page may be used to obtain approximate amps for other motors.

NOTE:

Actual Motor Amps may be higher or lower than the values listed below for a particular motor. For more reliable motor protection, NEC requires selection of heater elements by using the motor nameplate data. Motor nameplate data must be checked to determine proper size of heater coil before motor is energized.

3 Phase								
KW	HP	200V	208V	230V	380V	415V	460V	575V
		FLA	FLA	FLA	(50Hz) FLA	(50Hz) FLA	FLA	FLA
—	0.25(¼)	—	1.39	1.2	—	—	0.6	0.84
—	0.33(⅓)	—	1.69	1.46	—	—	0.73	0.58
0.37	0.5	2.5	2.4	2	1.3	.81	1.1	.9
0.55	0.75	3.7	3.5	3.2	1.8	1.21	1.6	1.3
0.75	1	4.8	4.6	4.2	2.3	2	2.1	1.7
1.1	1.5	6.9	6.6	6.0	3.3	2.5	3	2.4
1.5	2	7.8	7.5	6.8	4.3	3.5	3.4	2.7
2.2	3	11	10.6	9.6	6.1	5	4.8	3.9
3.7	5	17.5	16.7	15.2	9.7	7.5	7.6	6.1
5.5	7.5	25.3	24.2	22	14	11	11	9
7.5	10	32.2	30.8	28	18	14	14	11
11	15	48.3	46.2	42	27	21	21	17
15	20	62.1	59.4	54	34	28	27	22
18.5	25	78.2	74.8	68	44	35	34	27
22	30	92	88	80	51	40	40	32
30	40	120	114	104	66	55	52	41
37	50	150	143	130	83	64	65	52
45	60	177	169	154	103	80	77	62
55	75	221	211	192	128	100	96	77
75	100	285	273	248	165	135	124	99
90	125	359	343	312	208	165	156	125
110	150	414	396	360	240	200	180	144
147	200	552	528	480	320	260	240	192
185	250				403	325	302	242
220	300				532	385	361	289
257	350				620	450	414	336
295	400				709	500	477	382
335	450				797	728	515	412
375	500				886	809	590	472
445	600						656	523
	700						716	571
	800						775	618

Typical Schematic

For wiring diagrams please see the MCC Website Wiring Diagram Tool usa.siemens.com/mcc

Full Voltage Non Reversing (FVNR) Unit

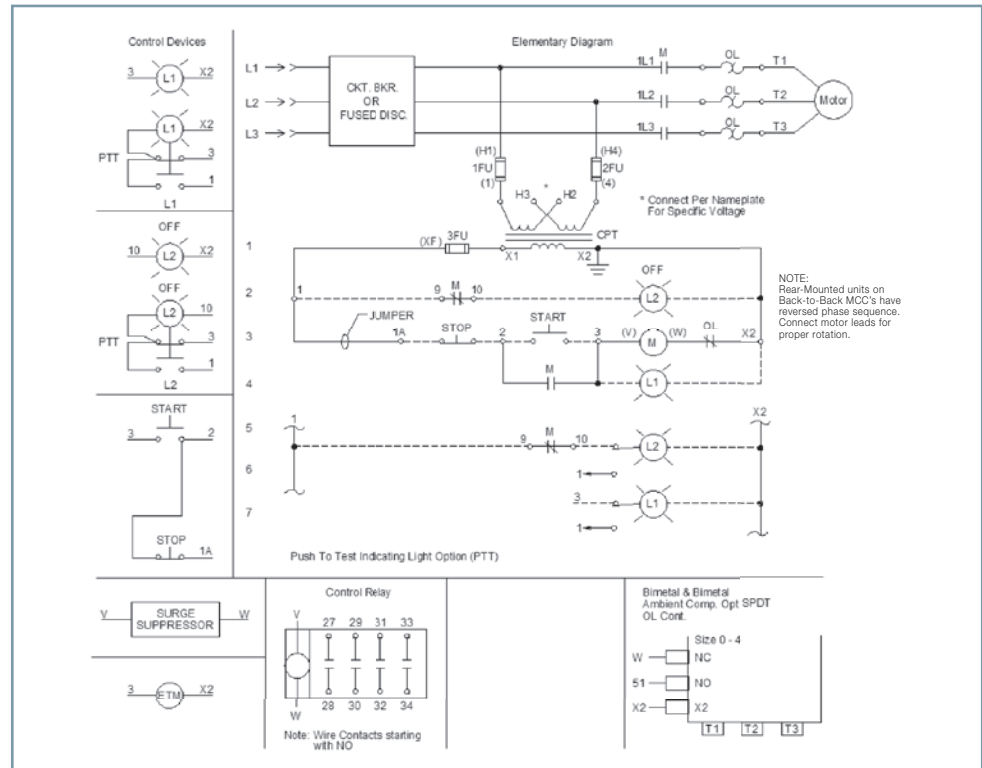

Figure 82. FVNR Schematic

Full Voltage Non Reversing (FVNR) High Density Unit

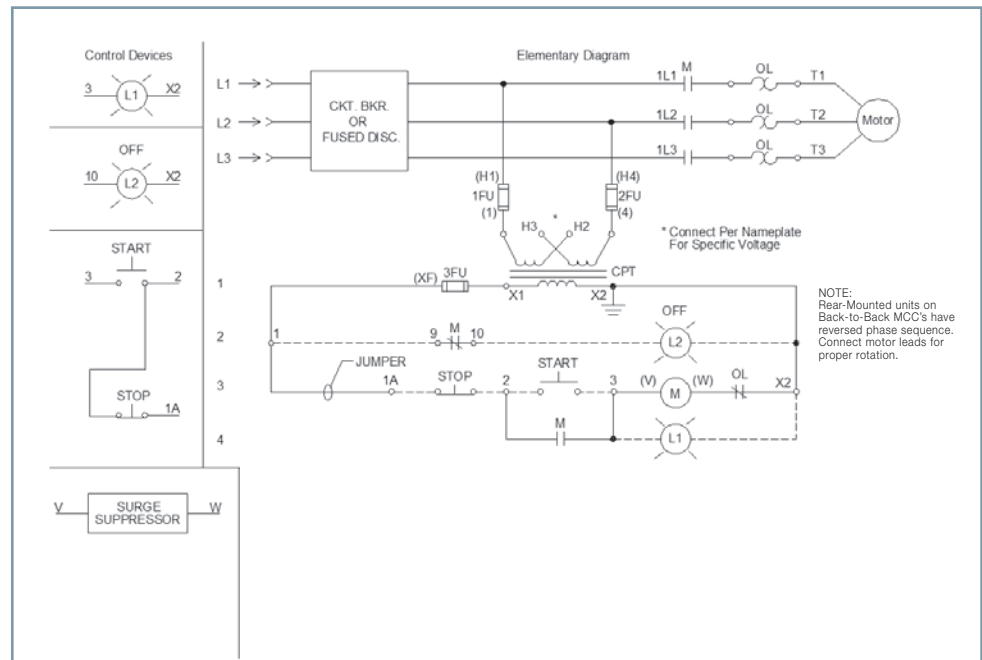

Figure 83. FVNR High Density Unit Schematic

Typical Schematic

Dual Full Voltage Non Reversing (FVNR) Unit

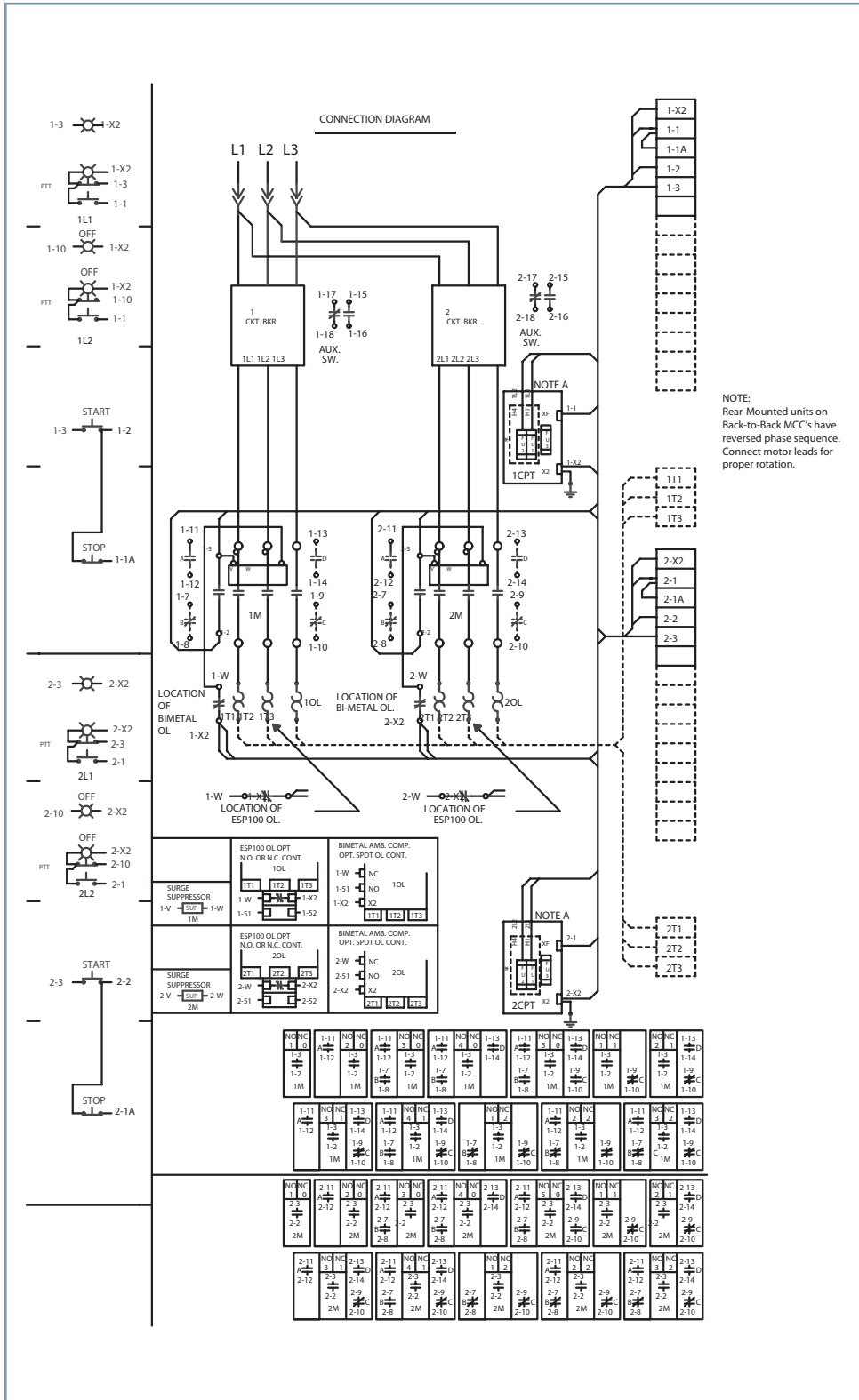

Figure 84. Dual FVNR Schematic

Typical Schematic

Full Voltage Contactor (FVC) Unit

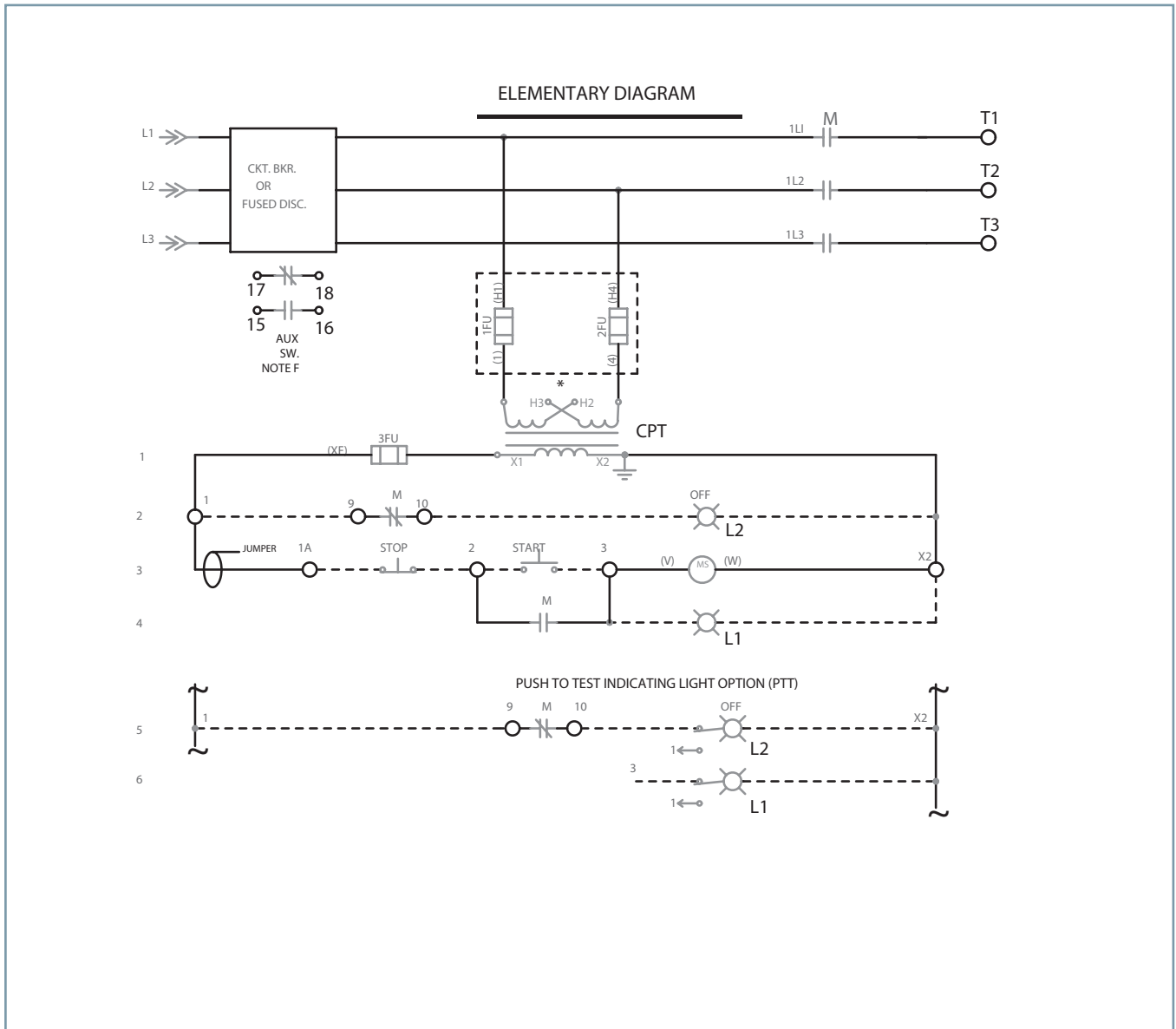

Figure 85. FVC Unit Schematic

Typical Schematic

Full Voltage Non Reversing (FVNR) ESP200 Overload Units

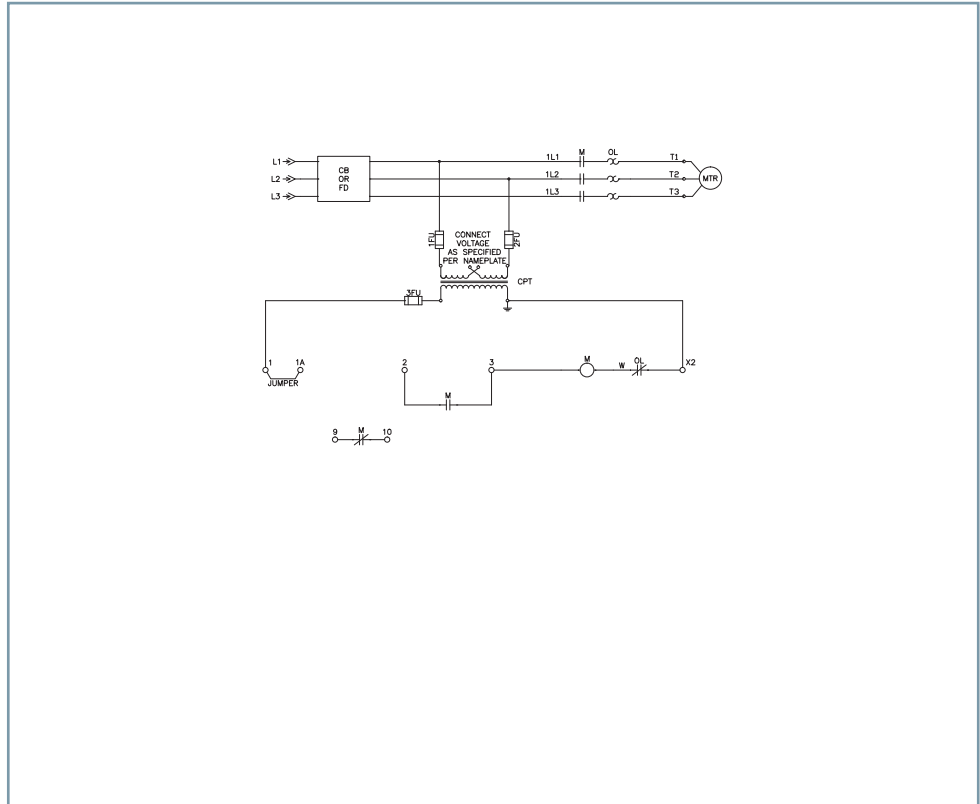

Figure 87. FVNR ESP200 Overload Unit Schematic

High Density Full Voltage Non Reversing (FVNR) ESP200 Overload Units

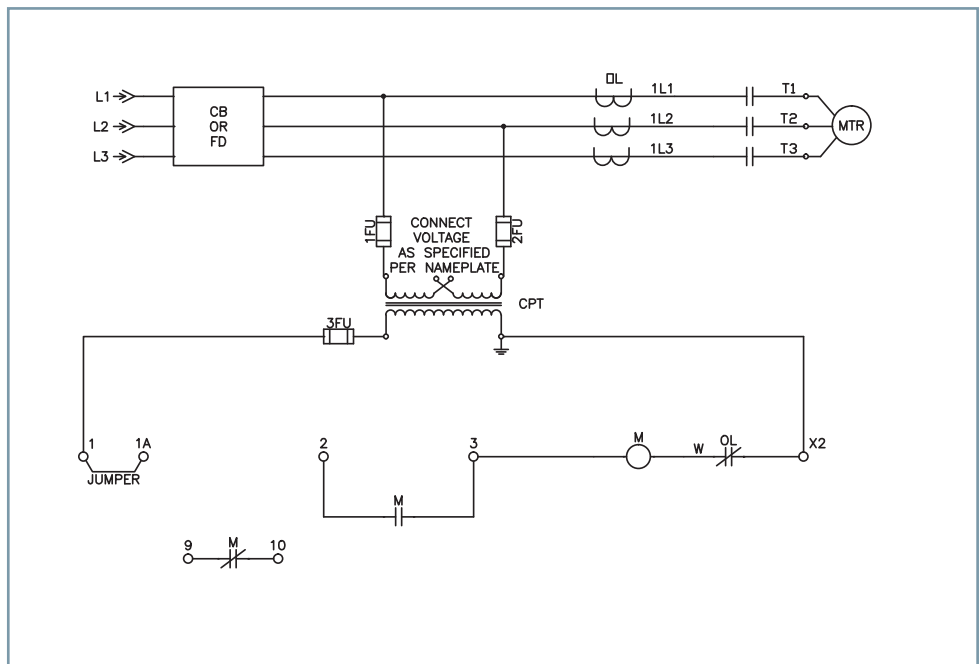

Figure 88. High Density FVNR ESP200 Overload Units

Typical Schematic

Full Voltage Non Reversing (FVNR) SIMCODE pro Unit

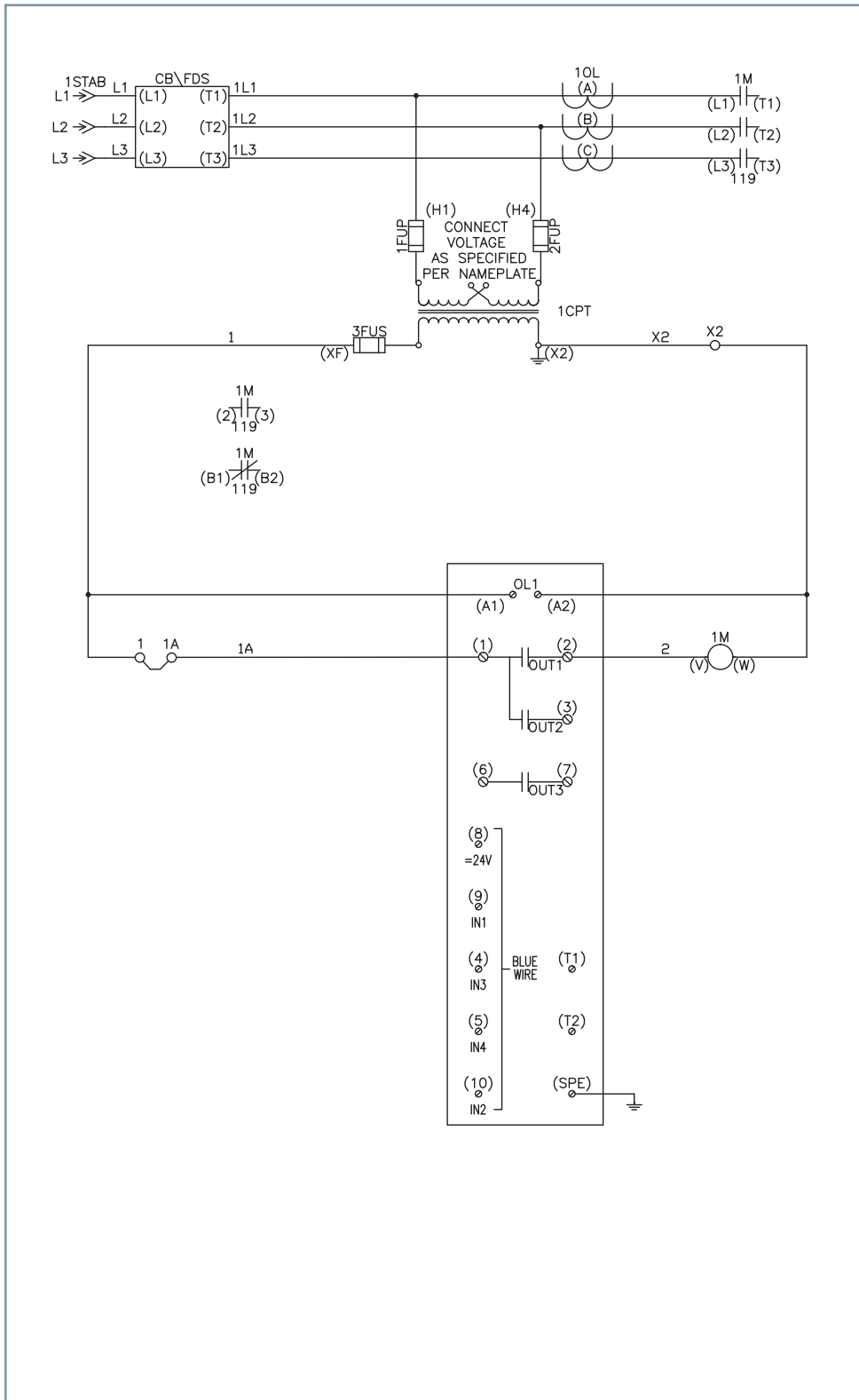

Figure 89. FVNR SIMOCODE pro Unit Schematic

Typical Schematic

Variable Frequency Drive Unit (with Micromaster 440)

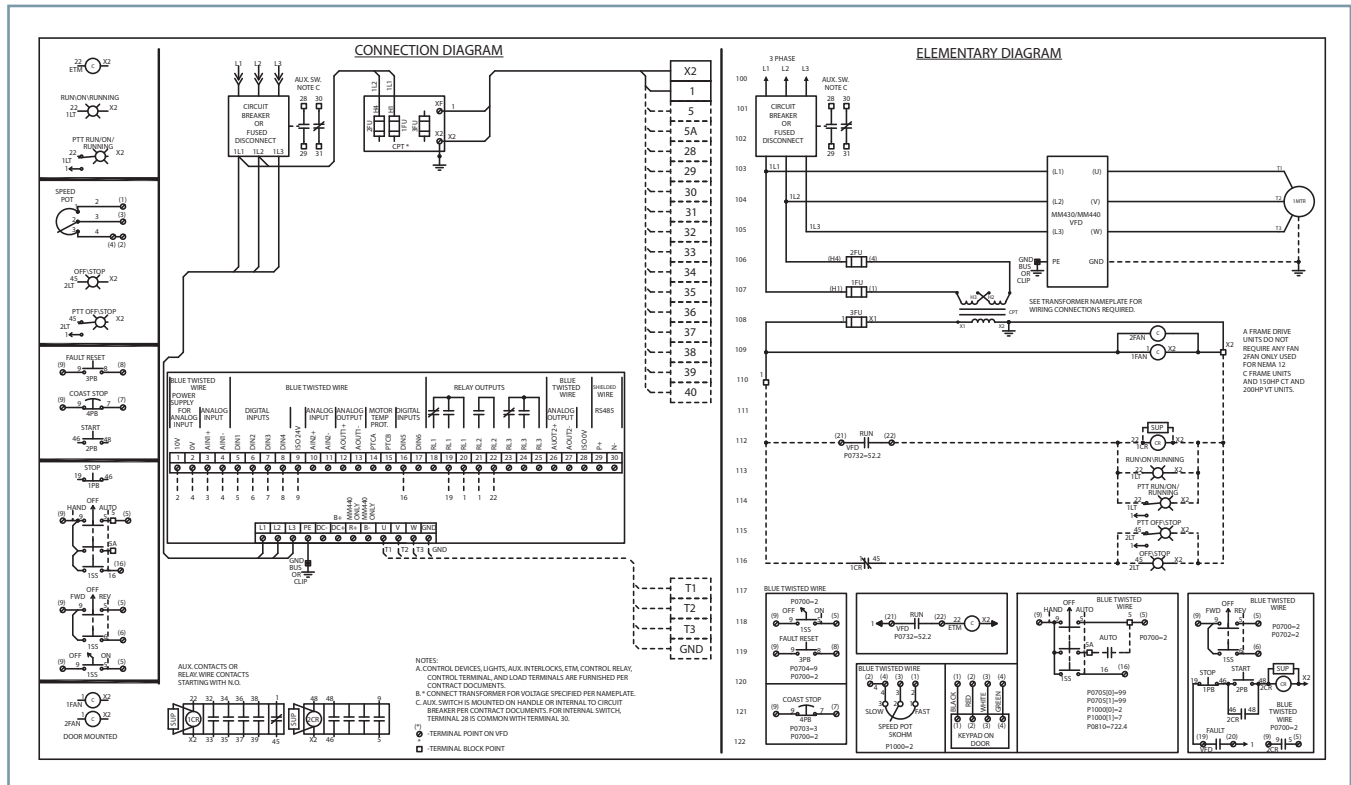

Figure 92. VFD Unit with MM440 Schematic

Aftermarket

Siemens is committed to serving our customers and supporting a full line of replacement components, renewal parts, and aftermarket units to maintain the value and use of existing tiastar and previous generation motor control centers.

Renewal Parts

Renewal parts for tiastar and legacy MCC are now available via Industry Mall and COMPAS. These kits represent the most requested renewal parts for field retrofit installations. Please use the MCC Aftermarket Renewal Parts Catalog, MCCS-AFTMKT-0613, which is available at www.usa.siemens.com/mccaftermarket to select the ordering items required.

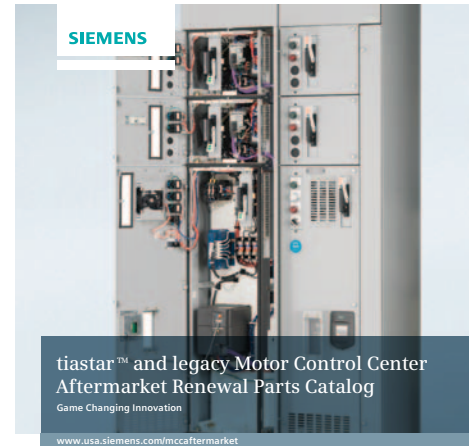

Answers for industry.

MCC Aftermarket Request Form

For an MCC aftermarket quote, please visit <http://www.usa.siemens.com/mccaftermarket> and fill out the online request form. Your request will be processed by a representative who will follow-up with you. For assistance in identifying the MCC, please use the MCC Identification Guide: CCBR-MCCAR-0813.

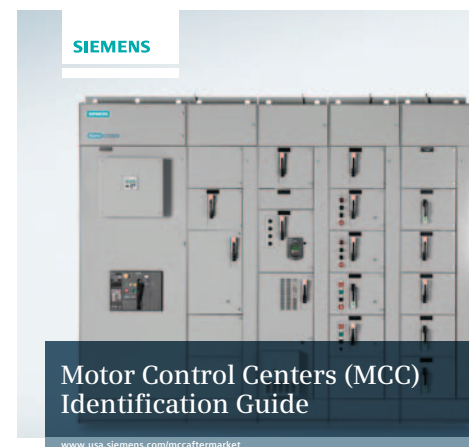

Answers for industry.

SECTION [26 24 19] [16443] LOW VOLTAGE MOTOR CONTROL CENTERS, ARC RESISTANT

PART 1 - GENERAL

1.1 SCOPE

- A. The requirements of the contract, Division [26] [16] applies to work in this section. Motor Control Centers as specified and as shown on the contract drawings shall be furnished and installed by the contractor.

1.2 RELATED DOCUMENTS

- A. *[Related sections include the following:*
1. *Section [26 29 23] [16269] – Variable-Frequency Motor Controllers*
 2. *Section [26 29 13.16] [16420] – Reduced Voltage Motor Controllers*
 3. *Section [26 36 23] [16415] – Automatic Transfer Switches*
 4. *Section [26 43 13] [16289] - Transient Voltage Suppression for Low-Voltage Electrical Power Circuits]*
 5. *Section [26 09 13.xx.xx] [16290] – Electrical Power Monitoring and Control*
 6. *Section [2622 19] [16461] – Control and Signal Transformers*
 7. *Section [26 24 16] [16442] - Panelboards*
 8. *Section [2628 16] [16410] – Enclosed Switches and Circuit Breakers]*

1.3 SUBMITTALS

- A. Product Data: Submit manufacturer's printed product data.
- B. Drawings: Submit shop drawings for approval. Drawings shall include all dimensions, weights, electrical ratings, wiring diagrams and required clearances.

1.4 RELATED STANDARDS

- A. The Motor Control Center shall be manufactured and tested according to the latest applicable standards of the following agencies:
1. UL 845 – Motor Control Centers
 2. NEMA ICS 18-2001 – Motor Control Centers
 3. NEMA ICS 1-2001 – Industrial Control and Systems: General Requirements
 4. NEMA ICS 2.3-2008 – Industrial Control and Systems: Instructions for the Handling, Installation, Operation, and Maintenance of Motor Control Centers
 5. ANSI/IEEE C37.20.7-2007 – Guide for Testing Metal-Enclosed Switchgear Rated up to 38kV for Internal Arcing Faults. *[Testing shall be witnessed by UL.]*
- B. *[Manufacturer Seismic Qualification: The low voltage motor control center(s) shall meet and be certified to seismic requirements specified in the [IBC 2012 International Building Code] [CBC 2013 California Building Code] [ASCE American Society of Civil Engineers 7-10].*
1. *The low voltage motor control center(s) shall be compliant with IBC 2012 parameters:*
 - a. *Building Occupancy Category (as defined in Table 1.5 from ASCE 2010): [I] [II] [III] [IV]*
 - b. *Seismic Design Category: [A] [B] [C] [D] [E] [F]*
 - c. *Site Class: [A – Hard Rock] [B - Rock] [C – Very dense soil and soft rock] [D – Stiff soil profile] [E – Soft Soil Profile] [F – Soil vulnerable to potential failure or collapse under seismic loading] as defined in IBC 2012 Table 1613.3.2 Site Class Definitions*
 - d. *I_p – Importance Factor: [1.5 – Components must function after an earthquake for life safety purposes (Building Occupancy Code IV)] [1.25 - Buildings and structures that represent a substantial hazard to human life in the event of failure or that can cause substantial economic impact or mass disruption of day-to-day civilian life (Building Occupancy Code III)] [1.0 – Non-essential buildings. Function not life critical. (Building Occupancy Code I and II)]*
 - e. *S_s – Mapped Spectral Accelerations for Short Periods at 0.2 seconds – 300%g*
 - f. *S_d – 5% Damped Design Spectral Response Accelerations for Short Periods at 0.2 seconds – 2.0*
 - g. *z/h – Height factor ratio: [] Note: Ratio is a calculated value equal to the floor the gear is installed on divided by 12. A 6th floor installation is a 0.5 value. A basement or ground floor installation is a 0.0 value.*

LOW VOLTAGE MOTOR CONTROL CENTERS, ARC RESISTANT (cont.)

1.5 QUALITY ASSURANCE

- A. Manufacturer: For equipment required for the work of this section, provide products which are the responsibility of one manufacturer.
- B. Manufacturer shall have had produced similar electrical equipment for a minimum of 5 years.
- C. Manufacturer shall be ISO 9001; 2008 certified.

1.6 DELIVERY, STORAGE AND HANDLING

- A. Handle and store equipment in accordance with manufacturer's Installation and Maintenance Manual. One (1) copy of this document shall be provided with the equipment at the time of shipment.

PART 2 - PRODUCTS

2.1 MANUFACTURERS

- A. *[The low voltage arc resistant motor control center shall be manufactured by Siemens, type tiastar Low Voltage Arc Resistant Motor Control Center or pre-approved equal. Approved manufacturers are Siemens and others.]*

2.2 RATINGS

- A. System Configuration: Motor Control Center suitable for application in three-phase, *[60 Hz] [50 Hz], [3 wire] [4 wire] [grounded-neutral] [3 wire ungrounded] [3 wire high-impedance grounded]* system.
- B. Electrical Ratings:
 - 1. Nominal System Voltage: *[600 V] [480 V] [240 V] [208 V] [Other (specify)].*
 - 2. Maximum Design Voltage: 600V
 - 3. Short-Circuit Current: *[42] [65]* kA
 - 4. Main-Bus Continuous Current: *[600] [800] [1200] [1600]* A.
 - 5. Accessibility Type: 2A
 - 6. Internal Arcing Short-Circuit Current: 65 kA without the need of a current limiting main device.
 - 7. Arcing Duration: 50 msec
 - 8. Internal arcing short-circuit current rating and arc duration shall be met without a current limiting main device.

2.3 GENERAL REQUIREMENTS

A. STRUCTURES

1. The enclosure shall be NEMA Type *[1], [1-with gasketed doors]*. Vertical sections shall be constructed with steel divider sheet assemblies formed or otherwise fabricated to eliminate open framework between adjacent sections or full-length bolted-on side sheet assemblies at the ends of the MCC(s).
2. Vertical sections shall be 102" high excluding mounting sills and including a 12" modified pull-box or top-hat with pressure flaps installed throughout the MCC for Arc Resistant purposes, 20" wide and 20" deep for front mounting of units. The width of the vertical section may be increased for special oversize units that cannot be accommodated in the standard 20" wide structure up to 30".
3. Vertical structures shall be divided into six (6) full space factors (12") and shall accommodate up to six (6) NEMA size 1 or 2 Full Voltage Non Reversing FVNR combination starters. MCC unit sizes shall be multiples of 1/2 space factor (6"). The vertical structures shall accommodate up to twelve (12) 6" high density units. The vertical structures shall accommodate up to six (6) 12" units with dual mounted feeders, for a total of up to twelve (12) 125 AF feeders.
4. Each standard 20" wide structure shall be supplied with a 4" wide vertical wireway. Wireways shall be completely isolated from all power busses. The rear surface of the vertical wireway shall be painted white and include openings for pressure release in case of an Arc Flash event. A minimum of three (3) formed wire cable supports, extending the full depth of the vertical wireway shall be supplied in each vertical section. A separate hinged door shall cover the vertical wireway.
5. Each standard structure shall be supplied with a 12 inch top and six (6) inch bottom horizontal wireway that are continuous for the entire length of the MCC. The minimum horizontal wireway opening between sections is 40 square inches for the top and 30 square inches for the bottom horizontal wireway. A hinged door shall be supplied to cover the top horizontal wireway.

6. Unit doors shall be hinged on the left and vertical wireway doors on the right for unobstructed access to the units and associated vertical wireway. All doors shall be mounted on removable pin-type hinges and secured with steel quarter-turn, into a secured support tested to withstand an Arc Flash event, indicating type fasteners.
7. Wireways shall be completely isolated from bus compartments by suitable barriers. Sliding barriers between the horizontal bus and top horizontal wireway are not acceptable.
8. Removable top cover plates shall be provided for conduit entry to the top horizontal wireway and shall provide a minimum of 116 square inches of area for conduit location. Top cover plates shall be fabricated from 13 gauge steel.
9. All MCC structures shall be supplied with 1-1/8" high X 3" wide base channel sills that are continuous for the entire length of the shipping split. The base channel sills shall be fabricated of 7 gauge steel and shall be suitable for grouting the base channel sills in place, welding to leveling plates or securing to the floor with 1/2" anchor bolts. MCC structures shall be supplied with reversible bottom end cover plates to cover the bottom horizontal wireway and ends of the base channel sills. The bottom end cover plates shall be factory installed to cover the ends of the base channel sills to prevent entrance of dirt and rodents into the MCC when installed flush on the floor and shall be removable to expose the ends of the base channel sills if they are to be grouted into the floor.
10. A removable, full length lifting angle shall be provided for each shipping split of each MCC. The lifting angle shall be bolted to each side sheet or divider sheet of the shipping split to evenly distribute the weight of the MCC during lifting.
11. MCC's shall be assembled in such a manner that it is not necessary to have rear accessibility to remove any internal devices or components.

B. BUSSING

1. The main horizontal bus shall be *(Pick a. or b. Delete the other. If a. is selected, then make decisions within the paragraph.)*
 - a. *[[Tin] [Silver] plated copper rated at [600] [800] [1200] [1600] amperes with a conductivity rating of 100% IACS. The horizontal bus bars shall be fully sized to carry 100% of the rated current the entire length of the MCC. Horizontal bus bars shall be mounted edge wise and located at the top of the MCC. Tapered horizontal bus is not acceptable.] All power bus shall be braced to withstand a fault current of 65,000 RMS symmetrical amperes.]*
 - b. *[The entire horizontal bus assembly must be located behind the top horizontal wireway at any amperage. Horizontal bus bars located behind usable unit space are not acceptable.]*
 - c. The horizontal bus shall be isolated from the top horizontal wireway by a clear, flexible, polycarbonate, barrier allowing visual inspection of the horizontal bus without removing any hardware.
2. The vertical bus:
 - a. Shall be rated *[300] [600]* amperes. Vertical bus bars shall be fabricated of *[tin] [silver]* plated solid copper bars with a conductivity rating of 100% IACS.
 - b. The vertical bus barrier support shall be designed as to effectively enclose each vertical bus bar, providing both isolation and insulation. Automatic shutter mechanisms shall be provided to close off all unused stab openings when a plug-in unit is moved to the "TEST" position or removed from the structure. Unused stab openings shall be covered with snap-in covers
3. All bus ratings are to be based on a maximum temperature rise of 50°C over a 40°C ambient temperature.
4. Horizontal to vertical bus and horizontal bus splice connections shall be made with two (2) 3/8" grade 5 bolts and conical washers at each connection point. All connecting hardware shall be designed to be tightened from the front of the MCC without applying any tools to the rear of the connection.
5. The horizontal ground bus shall be rated *[300 amp copper] [600 amp copper]*.

C. UNITS

1. Plug-in units shall connect to the vertical bus by means of self-aligning, tin plated copper stab-on connectors provided with spring steel back-up springs to insure positive connection to the vertical bus.
2. When vertical ground bus is specified, plug-in units shall include a ground stab which engages the vertical ground bus before the power stabs engage the vertical bus when the unit is inserted into the structure. When the plug-in unit is withdrawn from the vertical bus, the vertical ground stab shall release after the power stabs.
3. The interior of all MCC units shall be painted white, including unit top and bottom plates or isolation barriers.
4. All plug-in units 30" tall and larger will be secured to the structure in four (4) points to withstand an Arc Flash event.
5. All plug-in units 12" tall and larger will include two (2) auxiliary handles to aid in installation, removal and transporting plug-in units.

LOW VOLTAGE MOTOR CONTROL CENTERS, ARC RESISTANT (cont.)

6. All plug-in units will include a racking mechanism to assure full engagement with the stab-on connectors with the vertical bus.
 7. Plug-in units shall be provided with interference type draw-out to prevent complete removal of the plug-in unit from the structure in one motion. The interference mechanism shall also provide clear indication when the plug-in unit has been withdrawn to the "TEST" position.
 8. A mechanical interlock shall be supplied on all plug-in units to prevent insertion or removal of a unit from the structure when the unit operator handle is in the ON position. This interlock may not be defeated.
 9. Each 12" tall and larger plug-in unit shall be secured in the structure by two (2) readily accessible devices, one of which is tool operated. These devices shall be located at the front of the unit.
 10. Plug-in units with NEMA Type B or C wiring shall be supplied with unit terminal block mounted on the right hand side of the unit, adjacent to the vertical wireway. The terminal blocks shall be mounted on a movable bracket that maintains the terminals inside the unit structure for normal operation and pivots into the vertical wireway exposing the terminals for wiring, test and maintenance.
 11. All plug-in units shall include a positive means of grounding the unit to the structure at all times.
 12. All units that need ventilation (VFD units, RVSS units) shall have a protective plate in front of the louvers to deflect material exiting the unit in case of an Arc Flash event.
 13. The MCC unit disconnect operator for 600 ampere maximum units shall operate in a vertical, up-down, plane. High density units shall have horizontal motion. All unit disconnects shall remain engaged with the disconnect device at all times, regardless of the unit door position. The operating handles shall be interlocked with the unit door so that the door can neither be opened with the disconnect device in the ON position, nor can the disconnect device be turned ON with the unit door open except by operation of a defeater mechanism. Indication of the disconnect device shall be clearly indicated by the position of the operating handle. When applied with circuit breaker devices, the handle shall also provide clear indication of a circuit breaker trip.
 14. When pilot lights, push buttons or sector switches are specified. The devices shall be mounted in a formed metal device panel that is capable of accepting four (4) such devices in any combination. The device panel shall be secured to the unit door for normal operation, or mounted on the plug-in unit as required for unit removal and bench testing.
 15. Pilot devices shall be ***[22 mm in diameter, rated for NEMA 4 (IP 67) applications. Connections to 22 mm pilot devices shall be made to touch resistant screw type terminations. Pilot device contacts shall be rated at 10A, 600 VAC (NEMA A600 Same Polarity).] [heavy duty, oil tight 30mm devices with a NEMA 4 rating. Pilot device contacts shall be rated at 10A, 600 VAC (NEMA A600). The pilot device bodies shall be fabricated from metal.]***
 16. Unit identification nameplate shall be provided for each unit. Nameplates shall be a black surface with white core. Engraving shall cut through the gray surface exposing white lettering of the unit designation. Nameplates shall be 1" tall by 3 1/2" wide. Adhesives or glues are not an acceptable means of mounting unit nameplates.
- D. WIRING
1. The wiring shall be NEMA Class ***[1] [2]***, Type ***[A] [B] [C]***.
- E. COMBINATION MOTOR STARTERS
1. The combination starters shall be full voltage, non-reversing and provided with a Siemens ***[magnetic only circuit breaker] [fused disconnect]***, unless noted otherwise on the drawings.
 - a. Starters and disconnects shall be rated equal to or greater than the AIC rating of the gear.
 2. Overload Protection
 - a. The overload protection shall be:
 - 1.) ***[Bi-Metal Ambient compensated overload.]***
 - 2.) ***[Self power ESP solid state overload relay with NEMA Class [10] [20] [30] trip curve.]***
 3. Control Power
 - a. Each starter unit shall be provided with an encapsulated control power transformer of sufficient size to accommodate the contactor coil burden plus all specified auxiliary devices.
- F. FEEDERS
1. Feeder disconnects shall be Siemens ***[thermal-magnetic circuit breaker] [fused disconnect]***.

- G. **[METERING EQUIPMENT]**
1. *Provide a multi-function, high accuracy digital power metering instrumentation module equipped with LCD display. The power metering module shall provide simultaneous measurements for current, voltage and power parameters. Power meter shall be Siemens type [PAC 3100] [PAC 3200] [PAC4200] [9340] [9360] [9510] [9510ADR/RTU] [9610] equipped with a communications port for standard RS-485 connection.]*
- H. **[ARC FLASH]**
1. **[Labeling *Delete one or both of the next 2 sentences on arc flash.*]**
 - a. *[Apply in the field, the factory supplied arc flash warning label to all motor control centers that are in other than dwelling occupancies and are likely to require examination, adjustment, servicing, or maintenance while energized to warn qualified persons of potential electrical arc flash hazards.]*
 2. **[Dynamic Arc Flash Sentry *OPTIONAL*]**
 - a. *The main circuit breaker shall be a Siemens WL equipped with an ETU776 trip unit; field programmed with two trip curves. One curve shall be set to the levels determined by a coordination study. The second setting shall be set with instantaneous set down to a minimum acceptable level to trip the main rapidly on an arc flash event.*
 - b. **[Delete one or both of the next 2 items.]**
 - 1.) *[The settings shall be adjusted via terminals for connecting a field installed motion sensor. A blue light shall illuminate on the front of the MCC to denote when Dynamic Arc Flash Sentry is on.]*
 - 2.) *[The settings shall be adjusted via a 2 position selector switch. A blue light shall illuminate on the front of the MCC to denote when Dynamic Arc Flash Sentry is on.]*

PART 3 - EXECUTION

3.1 INSTALLATION

- A. Installation shall be per the manufacturer's recommendations, written instructions, final shop drawings, and contract documents. Installation shall be coordinated with adjacent work to ensure proper sequence of construction, clearances and support.
- B. The Motor Control Center shall not be placed in hazardous locations. The location shall be well ventilated and free from humidity, dust, and dirt. The temperature shall be no less than 32°F and no greater than 104°F. Protection shall be provided to prevent moisture from entering the enclosure.

3.2 TESTING

- A. Perform factory and installation tests in accordance with applicable NEMA and UL requirements.

3.3 WARRANTY

- A. Equipment manufacturer warrants that all goods supplied shall be free of non-conformities in workmanship and materials for one year from date of initial operation, and not more than eighteen months from date of shipment.

END OF SECTION

SECTION [26 24 19] [16443] LOW VOLTAGE MOTOR CONTROL CENTERS

PART 1 - GENERAL

1.1 SCOPE

- A. The requirements of the contract, Division [26] [16] applies to work in this section. Motor Control Centers as specified and as shown on the contract drawings shall be furnished and installed by the contractor.

1.2 RELATED DOCUMENTS

- A. *[Related sections include the following:*
1. *Section [26 29 23] [16269] – Variable-Frequency Motor Controllers*
 2. *Section [26 29 13.16] [16420] – Reduced Voltage Motor Controllers*
 3. *Section [26 36 23] [16415] – Automatic Transfer Switches*
 4. *Section [26 43 13] [16289] - Transient Voltage Suppression for Low-Voltage Electrical Power Circuits]*
 5. *Section [26 09 13.xx.xx] [16290] – Electrical Power Monitoring and Control*
 6. *Section [2622 19] [16461] – Control and Signal Transformers*
 7. *Section [26 24 16] [16442] - Panelboards*
 8. *Section [2628 16] [16410] – Enclosed Switches and Circuit Breakers*

1.3 SUBMITTALS

- A. Product Data: Submit manufacturer's printed product data.
- B. Documents: Submit shop drawings for approval. Documents shall include all dimensions, weights, electrical ratings, wiring diagrams and required clearances.

1.4 RELATED STANDARDS

- A. The Motor Control Center shall be manufactured and tested according to the latest applicable standards of the following agencies:
1. UL 845 – Motor Control Centers
 2. NEMA ICS 18-2001 – Motor Control Centers
 3. NEMA ICS 1-2001 – Industrial Control and Systems: General Requirements
 4. NEMA ICS 2.3-2008 – Industrial Control and Systems: Instructions for the Handling, Installation, Operation, and Maintenance of Motor Control Centers
- B. *[Manufacturer Seismic Qualification: The low voltage motor control center(s) shall meet and be certified to seismic requirements specified in the [IBC 2012 International Building Code] [CBC 2013 California Building Code] [ASCE American Society of Civil Engineers 7-10].*
1. *The low voltage motor control center(s) shall be compliant with IBC 2012 parameters:*
 - a. *Building Occupancy Category (as defined in Table 1.5 from ASCE 2010): [I] [II] [III] [IV]*
 - b. *Seismic Design Category: [A] [B] [C] [D] [E] [F]*
 - c. *Site Class: [A – Hard Rock] [B - Rock] [C – Very dense soil and soft rock] [D – Stiff soil profile] [E – Soft Soil Profile] [F – Soil vulnerable to potential failure or collapse under seismic loading] as defined in IBC 2012 Table 1613.3.2 Site Class Definitions*
 - d. *Ip – Importance Factor: [1.5 – Components must function after an earthquake for life safety purposes (Building Occupancy Code IV)] [1.25 - Buildings and structures that represent a substantial hazard to human life in the event of failure or that can cause substantial economic impact or mass disruption of day-to-day civilian life (Building Occupancy Code III)] [1.0 – Non-essential buildings. Function not life critical. (Building Occupancy Code I and II)]*
 - e. *Ss – Mapped Spectral Accelerations for Short Periods at 0.2 seconds – 300%g*
 - f. *Sds – 5% Damped Design Spectral Response Accelerations for Short Periods at 0.2 seconds – 2.0*
 - g. *z/h – Height factor ratio: [] Note: Ratio is a calculated value equal to the floor the gear is installed on divided by 12. A 6th floor installation is a 0.5 value. A basement or ground floor installation is a 0.0 value.*

1.5 QUALITY ASSURANCE

- A. Manufacturer: For equipment required for the work of this section, provide products which are the responsibility of one manufacturer.
- B. Manufacturer shall have had produced similar electrical equipment for a minimum of 5 years.
- C. Manufacturer shall be ISO 9001; 2008 certified.

1.6 DELIVERY, STORAGE AND HANDLING

- A. Handle and store equipment in accordance with manufacturer's Installation and Maintenance Manual. One (1) copy of this document shall be provided with the equipment at the time of shipment.

PART 2 - PRODUCTS

2.1 MANUFACTURERS

- A. *[The motor control centers shall be tiastar by Siemens or pre-approved equal. Approved manufacturers are Siemens and others.]*

2.2 GENERAL REQUIREMENTS

A. STRUCTURES

1. *[The enclosure shall be NEMA Type [1], [1A with gasketed doors], [2], [2-dripshield] [12], [3R non-walk-in]. Vertical sections shall be constructed with steel divider sheet assemblies formed or otherwise fabricated to eliminate open framework between adjacent sections or full-length bolted-on side sheet assemblies at the ends of the MCC(s).]*
2. *[Vertical sections shall be 90" high excluding mounting sills, 20" wide and [15"] [20"] deep for front mounting of units. Where indicated that arrangement is to accommodate front & rear mounting of units, the structure depth shall not exceed 21". The width of the vertical section may be increased for special oversize units that cannot be accommodated in the standard 20" side structure.]*
3. Vertical structures shall be divided into six (6) 12" space factors and shall accommodate six (6) full size NEMA size 1 or 2 Full Voltage Non Reversing FVNR combination starters. MCC unit sizes shall be multiples of 1/2 space factor (6"). The vertical structures shall accommodate 6" high density and dual mounted units.
4. Back-to-back, front and rear unit mounting, structures shall be 21" deep maximum and shall accommodate 12 full size NEMA size 1 or 2 Full Voltage Non Reversing FVNR combination starters per section.
5. Each standard 20" and 24" wide structure shall be supplied with a vertical wireway. 4" wide wireways shall be installed on 20" wide structures and 8" wide wireways on 24" wide structures. Wireways shall be completely isolated from all power busses. The rear surface of the vertical wireway shall be painted white. A minimum of three (3) formed wire cable supports, extending the full depth of the vertical wireway shall be supplied in each vertical section. A separate hinged door shall cover the vertical wireway.
6. Each standard structure shall be supplied with a 12 inch top and six (6) inch bottom horizontal wireway that are continuous for the entire length of the MCC. The minimum horizontal wireway opening between sections is 40 square inches for the top and 30 square inches for the bottom horizontal wireway. A hinged door shall be supplied to cover the top horizontal wireway.
7. Doors are to be hinged in a manner that allows for the removal of individual doors without the removal of any door above or below. Unit doors shall be hinged on the left and vertical wireway doors on the right for unobstructed access to the units and associated vertical wireway. All doors shall be mounted on removable pin-type hinges and secured with steel quarter-turn, indicating type fasteners.
8. Wireways shall be completely isolated from bus compartments by suitable barriers. Sliding barriers between the horizontal bus and top horizontal wireway are not acceptable.
9. Removable top cover plates shall be provided for conduit entry to the top horizontal wireway and shall provide a minimum of 116 square inches of area for conduit location. Top cover plates shall be fabricated from 13 gauge steel.
10. All MCC structures shall be supplied with 1-1/8" high X 3" wide base channel sills that are continuous for the entire length of the shipping split. The base channel sills shall be fabricated of 7 gauge steel and shall be suitable for grouting the base channel sills in place, welding to leveling plates or securing to the floor with 1/2" anchor bolts. MCC structures shall be supplied with reversible bottom end cover plates to cover the bottom horizontal wireway and ends of the base channel sills. The bottom end cover plates shall be factory installed to cover the ends of the base channel sills to prevent entrance of dirt and rodents into the MCC when installed flush on the floor and shall be removable to expose the ends of the base channel sills if they are to be grouted into the floor.

LOW VOLTAGE MOTOR CONTROL CENTERS

11. A removable, full length lifting angle shall be provided for each shipping split of each MCC. The lifting angle shall be bolted to each side sheet or divider sheet of the shipping split to evenly distribute the weight of the MCC during lifting.
 12. MCC's shall be assembled in such a manner that it is not necessary to have rear accessibility to remove any internal devices or components.
- B. BUSSING
1. **The main horizontal bus shall be (Pick a. or b.)**
 - a. *[[Tin][Silver] plated copper rated at [600][800][1200][1600][2000][2500] amperes with a conductivity rating of 100% IACS. The horizontal bus bars shall be fully sized to carry 100% of the rated current the entire length of the MCC. Horizontal bus bars shall be mounted edge wise and located at the top of the MCC. Tapered horizontal bus is not acceptable.] All power bus shall be braced to withstand a fault current of [42,000][65,000][100,000] RMS symmetrical amperes.]*
 - b. *[Tin plated aluminum rated at [600][800][1200] amperes. All power bus shall be braced to withstand a fault current of [42,000][65,000] RMS symmetrical amperes.]*
 - c. The entire horizontal bus assembly must be located behind the top horizontal wireway at any amperage. Horizontal bus bars located behind usable unit space are not acceptable.
 - d. The horizontal bus shall be isolated from the top horizontal wireway by a clear, flexible, polycarbonate, barrier allowing visual inspection of the horizontal bus without removing any hardware.
 2. **The vertical bus:**
 - a. *Shall be rated [300][600] amperes. Vertical bus bars shall be fabricated of [tin][silver] plated solid copper bars with a conductivity rating of 100% IACS.*
 - b. *[Pick one of the following 4; delete the other 3.] [The vertical bus assembly shall be isolated from the unit mounting space by means of a full height steel barrier. Provisions shall be made to close off unused unit stab openings in the vertical bus barrier with removable covers.]*
 - c. *[The vertical bus assembly shall be isolated from the unit mounting space by means of a full height steel barrier. Automatic shutter mechanisms shall be provided to close off all unused stab openings when a plug-in unit is moved to the "TEST" position or removed from the structure. Unused stab openings shall be covered with snap-in covers.]*
 - d. *[The vertical bus barrier support shall be designed as to effectively enclose each vertical bus bar. Provisions shall be made to close off unused unit stab openings in the vertical bus barrier with removable covers.]*
 - e. *[The vertical bus barrier support shall be designed as to effectively enclose each vertical bus bar. Automatic shutter mechanisms shall be provided to close off all unused stab openings when a plug-in unit is moved to the "TEST" position or removed from the structure. Unused stab openings shall be covered with snap-in covers.]*
 3. All bus ratings are to be based on a maximum temperature rise of *[50°C][65°C]* over a 40°C ambient temperature.
 4. Horizontal to vertical bus and horizontal bus splice connections shall be made with two (2) 3/8" grade 5 bolts and conical washers at each connection point. All connecting hardware shall be designed to be tightened from the front of the MCC without applying any tools to the rear of the connection.
 5. The horizontal ground bus shall be rated *[300 amp copper][600 amp copper][600 amp aluminum]*.
 6. The neutral bus connection shall be rated *[600 amp copper][1200 amp copper][1600 amp copper]*.
- C. UNITS
1. Plug-in units shall connect to the vertical bus by means of self-aligning, tin plated copper stab-on connectors provided with spring steel back-up springs to insure positive connection to the vertical bus.
 2. When vertical ground bus is specified, plug-in units shall include a ground stab which engages the vertical ground bus before the power stabs engage the vertical bus when the unit is inserted into the structure. When the plug-in unit is withdrawn from the vertical bus, the vertical ground stab shall release after the power stabs.
 3. The interior of all MCC units shall be painted white, including unit top and bottom plates or isolation barriers.
 4. All plug-in units 12" tall and larger will include two (2) auxiliary handles to aid in installation, removal and transporting plug-in units.

5. All plug-in units will include a racking mechanism to assure full engagement with the stab-on connectors with the vertical bus.
 6. Plug-in units shall be provided with interference mechanism type draw-out to prevent complete removal of the plug-in unit from the structure in one motion. The interference mechanism shall also provide clear indication when the plug-in unit has been withdrawn to the "TEST" position.
 7. A mechanical interlock shall be supplied on all plug-in units to prevent insertion or removal of a unit from the structure when the unit operator handle is in the ON position. This interlock may not be defeated.
 8. Each 12" tall and larger plug-in unit shall be secured in the structure by two (2) readily accessible devices, one of which is tool operated. These devices shall be located at the front of the unit.
 9. Plug-in units with NEMA Type B or C wiring shall be supplied with unit terminal block mounted within the unit, adjacent to the vertical wireway. For non-high density units, the terminal blocks shall be mounted on a movable bracket that maintains the terminals inside the unit structure for normal operation and pivots into the vertical wireway exposing the terminals for wiring, test and maintenance.
 10. All plug-in units shall include a positive means of grounding the unit to the structure at all times.
 11. The MCC unit disconnect operator shall operate in a vertical, up-down, plane. 6" units shall operate in a horizontal motion. All unit disconnects shall remain engaged with the disconnect device at all times, regardless of the unit door position. The operating handles shall be interlocked with the unit door so that the door can neither be opened with the disconnect device in the ON position, nor can the disconnect device be turned ON with the unit door open except by operation of a defeater mechanism. Indication of the disconnect device shall be clearly indicated by the position of the operating handle. When applied with circuit breaker devices, the handle shall also provide clear indication of a circuit breaker trip.
 12. When pilot lights, push buttons or sector switches are specified. The devices shall be mounted in a formed metal device panel that is capable of accepting four (4) such devices in any combination. The device panel shall be secured to the unit door for normal operation, or mounted on the plug-in unit as required for unit removal and bench testing.
 13. ***Pilot devices [shall be 22 mm in diameter, rated for NEMA 4 (IP 67) applications. Connections to 22 mm pilot devices shall be made to touch resistant screw type terminations. Pilot device contacts shall be rated at 10A, 600 VAC (NEMA A600 Same Polarity).] [Pilot devices shall be heavy duty, oil tight 30mm devices with a NEMA 4 rating. Pilot device contacts shall be rated at 10A, 600 VAC (NEMA A600). The pilot device bodies shall be fabricated from metal.]***
 14. Unit identification nameplate shall be provided for each unit. Nameplates shall be a black surface with white core. Engraving shall cut through the black surface exposing white lettering of the unit designation. Nameplates shall be 1" tall by 3 1/2" wide. Adhesives or glues are not an acceptable means of mounting unit nameplates.
- D. WIRING
1. The wiring shall be NEMA Class ***[1] [2]***, Type ***[A] [B] [C]***.
- E. COMBINATION MOTOR STARTERS
1. The combination motor starters shall be provided with a Siemens ***[magnetic only circuit breaker][thermal magnetic circuit breaker][fused disconnect]***, unless noted otherwise on the drawings.
 - a. Combination Motor Starters shall be rated equal to or greater than the AIC rating of the Motor Control Center.
 2. Overload Protection
 - a. The overload protection shall be:
 - 1.) ***[Bi-Metal Ambient compensated overload.]***
 - 2.) ***[Self power ESP solid state overload relay with NEMA Class [10] [20] [30] trip curve.]***
 - 3.) ***[SIMOCODE solid state overload relay with Class 5-40 protection multifunctional, electronic full motor protection. Detailed operating, service, and diagnostics data via PROFIBUS.]***
 3. Control Power
 - a. Each starter unit shall be provided with an encapsulated control power transformer of sufficient size to accommodate the contactor coil burden plus all specified auxiliary devices.
- F. FEEDERS
1. Feeder disconnects shall be Siemens ***[thermal-magnetic circuit breaker] [fused disconnect]***.

LOW VOLTAGE MOTOR CONTROL CENTERS

- G. **[ARC FLASH]**
1. **Labeling [OPTIONAL]**
 - a. *[Apply in the field, the factory supplied arc flash warning label to all motor control centers that are in other than dwelling occupancies and are likely to require examination, adjustment, servicing, or maintenance while energized to warn qualified persons of potential electrical arc flash hazards.]*
 2. **[Dynamic Arc Flash Sentry [OPTIONAL]]**
 - a. *The main circuit breaker shall be a Siemens WL equipped with an ETU776 trip unit; field programmed with two trip curves. One curve shall be set to the levels determined by a coordination study. The second setting shall be set with instantaneous set down to a minimum acceptable level to trip the main rapidly on an arc flash event.*
[Delete one or both of the next 2 items.]
 - 1.) *[The settings shall be adjusted via terminals for connecting a field installed motion sensor. A blue light shall illuminate on the front of the MCC to denote when Dynamic Arc Flash Sentry is on.]*
 - 2.) *[The settings shall be adjusted via a 2 position selector switch. A blue light shall illuminate on the front of the MCC to denote when Dynamic Arc Flash Sentry is on.]*

2.3 SMART MOTOR STARTER

- A. Motor starter units shall include a microprocessor based protective and control overload that provides NEMA class 5,10,15, 20, 25, 30, 35 or 40 thermal trip characteristics, phase asymmetry (phase imbalance & phase loss) protection, stalled rotor protection, instantaneous over current (jam) and under current protection and provisions for connecting one thermister. Upper and lower current limits shall be adjustable for tripping and monitoring..
- B. The device shall provide an option of voltage and power monitoring as well as monitoring of power factor (cos-phi or loss of load) protection. Device shall have internal and external ground fault monitoring capabilities to an exacting 0.3 amp equipment protection. Additionally the device shall have an option of monitoring three RTD's (PT100 or PT1000) temperature sensors or three NTC thermister sensors. **[The device shall have two analog inputs and one analog output with a [0 to 20m amp] [4 to 20m amp] signal.]**
- C. All protective functions shall be programmable to initiate a fault (trip) or warning. The device shall have the ability to designate its inputs as external fault inputs for hardwiring into upstream or downstream parts of the application. Running status of the connected load shall be determined by monitoring motor current to give a true indication of running status. The device shall provide monitoring of operating hours, downtime hours, number of starts, overload trips and have permissible starting capabilities.
- D. The device shall contain four digital inputs and three relay output points for use in controlling the motor starter. **[There shall be two additional digital modules with 4I/2O, and they shall have [bi-stable] [mono-stable] output contacts.]** Output relays shall be programmable to either turn off or retain their status in the event of a control voltage loss or network failure.
- E. The device shall also include on board logic elements including up to a total of six 3I/1O truth tables, two 2I/1O truth tables, and one 5I/2O truth table.
- F. The device shall have up to four signal conditioners and four non-volatile elements with adjustable (edge rising with memory, edge falling with memory, inverting and non-inverting) conditions. Additional elements shall include up to four timers with adjustable (with closing delay, closing delay with memory, with off delay, with fleeting closing) conditions and four limit monitors for overshoots and undershoots of any of its analog signals.
- G. The device shall communicate via PROFIBUS-DP to a central master controller and provide motor current, in percent of the motor full load amps, input and output data, status messages ON, OFF, under and over current warning and trip on a continuous cyclical basis.
- H. The user shall have the ability to remotely monitor and program all programmable parameters, diagnostic data and operating data.
- I. The device shall communicate at a maximum of 1.5Mbit Profibus communication speed, and shall be auto baud rate sensing. The device shall be able to send 244 bytes per telegram and 64 bytes of diagnostics.
- J. In the event of a communication network failure or PLC failure, the device shall operate as a stand-alone device. Upon restoration of the PROFIBUS network, the device shall resume communication with the network.

2.4 NETWORK *[If you are using an AS-interface, remove the last two sentences.]*

- A. *[The Siemens Smart Motor Control Center shall be connected to the customer's existing system via the Profibus network scanner located in the customer's PLC. These network scanners shall provide full Profibus network connectivity.] [The Siemens Smart Motor Control Center shall be connected to the customer's existing system via a Network Gateway. The network gateway shall provide restricted Profibus network connectivity.] [The Siemens Smart Motor Control Center shall be a stand alone system.]*
- B. Siemens tiastar Smart Motor Control Center is supplied with *[Profibus DP] [AS-Interface]*. These networks shall be installed at the factory to provide simplify commissioning on site. *[Select either 2.4.B.1 or 2.4.B.2. Delete the other section]*
 - 1. *[AS-Interface]*
 - a. *AS-Interface networking shall be used for the passing of low level binary information to and from tiastar Smart Motor Control Center devices. Maximum electrical cable length is 100m with a 5ms cycle time.*
 - b. *Each AS-Interface network must consist of 1 AS-Interface Master Unit and may connect up to 31 AS-Interface module slaves located within the tiastar Smart Motor Control Center units. There may be as many AS-Interface networks as the higher level operating system can control.*
 - c. *The AS-Interface network is connected throughout the tiastar Smart MCC via a copper two wire twisted pair daisy chained from the master unit to each subsequent unit. These wires terminate into pull-apart terminals at each unit to keep network integrity if the unit is withdrawn from the vertical section.*
 - d. *The AS-Interface Master provides all AS-I network support functions and also the data transfer to Profibus DP. The AS-Interface Power Supply generates the AS-interface slave control power as well as the data decoupling feature to send both power and data over the same two wires. The AS-Interface Master Unit must contain both the Master and Power Supply. Each AS-Interface Master Unit and its connected network devices shall be considered a single Profibus DP slave within a tiastar Smart Motor Control Center.]*
 - 2. *[Profibus DP]*
 - a. *Profibus DP networking shall be used for the passing of binary and analog data to and from tiastar Smart Motor Control Center devices. Maximum electrical cable length 400m at 500kbps; 200m at 1.5Mbps. Distances of 3000m are possible with the use of fiber optic cable.*
 - b. *Each Profibus DP network shall connect to up to 126 nodes. The Profibus DP network may have up to 10 segments with up to 30 nodes in each. Profibus segments are connected via the Profibus Repeater. There shall be as many Profibus DP networks as the higher level operating system can control.*
 - c. *The Profibus DP network shall connect throughout the tiastar Smart MCC via copper RS485 shielded twisted two wire Profibus cable daisy chained from unit to unit. These cables terminate into Profibus connectors at each unit with a Profibus communication port. Cables terminated within the Profibus connector shall maintain network connectivity when the unit is withdrawn from the vertical section.*
 - d. *Profibus repeater units shall provide data signal amplification and bus segment connection. Standard integral bus terminating resistor shall be provided through the Profibus connector. Each connector shall have a switch built in that turns the terminating resistor on and off. [OPTIONAL An active Profibus terminator shall provide consistent Profibus DP network termination that does not rely on node control power or connector switch position].]*

2.5 METERING

- A. Multifunction digital-metering monitors shall be, microprocessor-based unit suitable for three or four wire systems. Units shall communicate via:
 - 1. *[Profibus DP module] (SIEMENS Preferred method)*
 - 2. *[ModBus TCP port]*
 - 3. *[ModBus RTU expansion module].*
- B. *The meter shall mounted on the door and shall meter [at the Main Lugs] [at the Main Breaker] [as shown on the drawings].*
- C. *[Metering Equipment]*
 - 1. *Provide a multi-function, high accuracy digital power metering instrumentation module equipped with LCD display. The power metering module shall provide simultaneous measurements for current, voltage and power parameters. Power meter shall be Siemens type [PAC 3100] [PAC 3200] [PAC4200] equipped with a communications port for standard RS-485 connection.*

PART 3 - EXECUTION**3.1 INSTALLATION**

- A. Installation shall be per the manufacturer's recommendations, written instructions, final shop drawings, and contract documents. Installation shall be coordinated with adjacent work to ensure proper sequence of construction, clearances and support.
- B. The Motor Control Center shall not be placed in hazardous locations. The location shall be well ventilated and free from humidity, dust, and dirt. The temperature shall be no less than 32°F and no greater than 104°F. Protection shall be provided to prevent moisture from entering the enclosure.

3.2 TESTING

- A. Perform factory and installation tests in accordance with applicable NEMA and UL requirements.

3.3 WARRANTY

- A. Equipment manufacturer warrants that all goods supplied shall be free of non-conformities in workmanship and materials for one year from date of initial operation, and not more than eighteen months from date of shipment.

END OF SECTION

MCC Training

Those who are new to the industrial technologies might find the STEP (Siemens Technical Education Program) website and the MCC course helpful. The link to the MCC Online Training Course can be found here:

www.usa.siemens.com/step



Siemens Industry, Inc.
Industry Automation Division
3333 Old Milton Parkway
Alpharetta, GA 30005
1-800 -241-4453

info.us@siemens.com

www.usa.siemens.com/mcc

Subject to change without prior notice.
Order No: CCPC-CATAG-0916
All rights reserved.
Printed in USA
©2016 Siemens Industry, Inc.

The information provided in this brochure contains merely general descriptions or characteristics of performance which in case of actual use do not always apply as described or which may change as a result of further development of the products. An obligation to provide the respective characteristics shall only exist if expressly agreed in the terms of contract.

All product designations may be trademarks or product names of Siemens AG or supplier companies whose use by third parties for their own purposes could violate the rights of the owners.