

THIS COPY IS PROVIDED ON A RESTRICTED BASIS AND IS NOT TO BE USED IN ANY WAY DETRIMENTAL TO THE INTERESTS OF PANDUIT CORP.

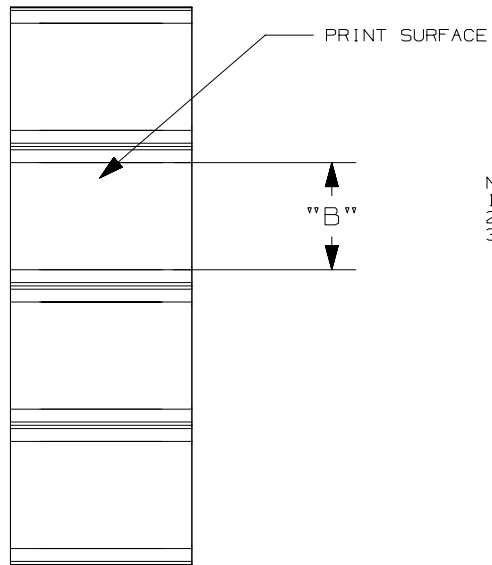
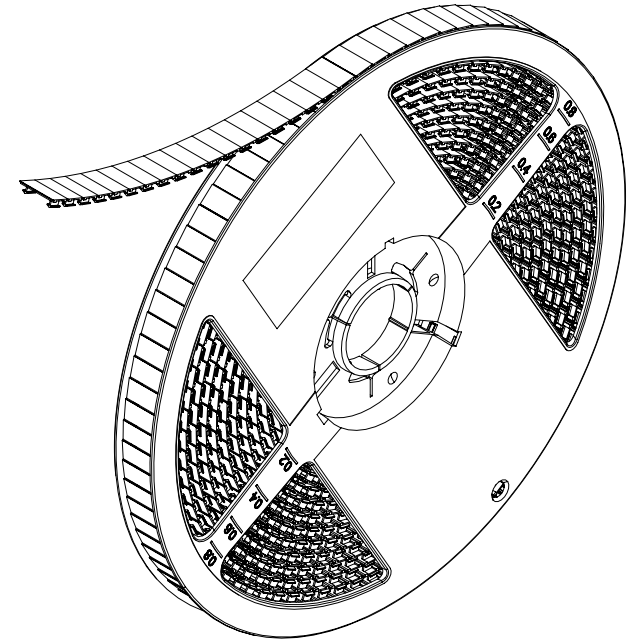
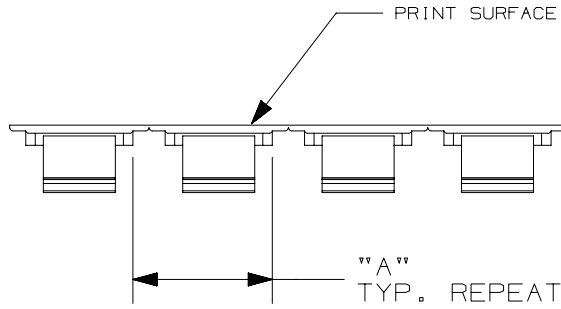
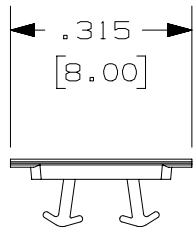

- NOTES:
 1. MILLIMETERS ARE DENOTED IN [].
 2. PRODUCT TO BE USED WITH PANDUIT TDP43ME PRINTER
 3. USE RESIN RIBBON (RMER1BL, RMER2BL, OR RMER4BL) FOR OPTIMAL PRINT RESULTS

PART NUMBER	COLOR	DIM "A"	DIM "B"	LABELS PER REEL	ALLEN BRADLEY COMPATIBLE TERMINAL BLOCKS	WEIDMUELLER COMPATIBLE TERMINAL BLOCKS
TB05X08EWT-AB2	WHITE	0.200" [5.08]	0.160" [4.08]	1000	1492-JD3, 1492-L3	WDR 2.5
TB06X08EWT-AB2	WHITE	0.242" [6.14]	0.205" [5.02]	1000	1492-JD4, 1492-L4	WDR 4

TITLE
TB05X08EWT-AB2, TB06X08EWT-AB2 TERMINAL BLOCK MARKERS
 CUSTOMER DRAWING

ITEM REVISION NAME
14I130BE/04

DATASET FILE NAME
14I130BE_DS_C11712/00



UNLESS OTHERWISE SPECIFIED,
 DIMENSIONAL TOLERANCES ARE: IN [mm]
 .x ± .1 [2.54] .xxx ± .010 [.254]
 .xx ± .02 [.50] ANGLES ± 3 °

MATERIAL:
THERMOPLASTIC POLYURETHANE ELASTOMER

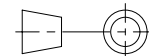

THIRD ANGLE PROJECTION

DRAWING NUMBER:
C11712

00	11/29/17	ZSG	MSAD	JW	INITIAL RELEASE	GAECN04412
----	----------	-----	------	----	-----------------	------------

REV	DATE	BY	CHK	APR	DESCRIPTION	ECN	DRAWN BY	DATE	CHK	SCALE	SHT 1 OF 1	SIZE
							ZSG	11/29/17	MSAD	3:1		A

D10100DA/20