



Guardmaster Safedge Pressure Sensitive Safety Edge System

Bulletin Number 440F



Allen-Bradley

by ROCKWELL AUTOMATION

Guardmaster®

User Manual

Original Instructions

Important User Information

Read this document and the documents listed in the additional resources section about installation, configuration, and operation of this equipment before you install, configure, operate, or maintain this product. Users are required to familiarize themselves with installation and wiring instructions in addition to requirements of all applicable codes, laws, and standards.

Activities including installation, adjustments, putting into service, use, assembly, disassembly, and maintenance are required to be carried out by suitably trained personnel in accordance with applicable code of practice.

If this equipment is used in a manner not specified by the manufacturer, the protection provided by the equipment may be impaired.

In no event will Rockwell Automation, Inc. be responsible or liable for indirect or consequential damages resulting from the use or application of this equipment.

The examples and diagrams in this manual are included solely for illustrative purposes. Because of the many variables and requirements associated with any particular installation, Rockwell Automation, Inc. cannot assume responsibility or liability for actual use based on the examples and diagrams.

No patent liability is assumed by Rockwell Automation, Inc. with respect to use of information, circuits, equipment, or software described in this manual.

Reproduction of the contents of this manual, in whole or in part, without written permission of Rockwell Automation, Inc., is prohibited.

Throughout this manual, when necessary, we use notes to make you aware of safety considerations.



WARNING: Identifies information about practices or circumstances that can cause an explosion in a hazardous environment, which may lead to personal injury or death, property damage, or economic loss.



ATTENTION: Identifies information about practices or circumstances that can lead to personal injury or death, property damage, or economic loss. Attentions help you identify a hazard, avoid a hazard, and recognize the consequence.

IMPORTANT Identifies information that is critical for successful application and understanding of the product.

Labels may also be on or inside the equipment to provide specific precautions.



SHOCK HAZARD: Labels may be on or inside the equipment, for example, a drive or motor, to alert people that dangerous voltage may be present.



BURN HAZARD: Labels may be on or inside the equipment, for example, a drive or motor, to alert people that surfaces may reach dangerous temperatures.



ARC FLASH HAZARD: Labels may be on or inside the equipment, for example, a motor control center, to alert people to potential Arc Flash. Arc Flash will cause severe injury or death. Wear proper Personal Protective Equipment (PPE). Follow ALL Regulatory requirements for safe work practices and for Personal Protective Equipment (PPE).

The following icon may appear in the text of this document.



Identifies information that is useful and can help to make a process easier to do or easier to understand.

	Preface	
	About This Publication	5
	Summary of Changes	5
	Additional Resources	5
	Chapter 1	
Product Overview	Safety Edge System Description	7
	Storage and Handling	7
	Storage	7
	Handling and Transport	7
	Safedge Selection	8
	Selection Procedure	8
	Components	10
	Compliance	11
	Installation of the Safedge Safety Edge System	12
	Install the C Rail	12
	Mount the C Rail	12
	Assemble and Install the Safedge Profile	13
	Sensing Surface of Safedge Safety Edge System	14
	Force Travel Relationship	15
	Deformation Travels	16
	Select the Cushion Factor	17
	Mounting	17
	Terminal Connections	18
	Declaration of Conformity	18
	CE Conformity	18
	UKCA Conformity	18
	Chapter 2	
Installation and Wiring	Electrical Connections	19
	Profile Connection	21
	Connect in Series	21
	Connect in Parallel	21
	Chapter 3	
Commissioning and Sequence of Operation	Manual Reset Mode	23
	Automatic Reset Mode	23
	Comparative Properties	24
	Typical Wiring Diagrams	25
	Chapter 4	
Maintenance and Service	Troubleshooting	27
	Maintenance	27
	Profile Cleaning	27
	Routine Maintenance Inspection and Test	28
	Thorough Examination and Test	28

	Repair	29
	Appendix A	
Specifications	Control Unit Specifications	31
	Safedge Profiles.....	32
	Appendix B	
Routine Inspection and Test	Written Log	34

About This Publication

This manual provides instructions on how to store, handle, install, wire, maintain, and service a Safedge™ system.

IMPORTANT Read this manual in full before installation. After installation, retain this manual in a safe and accessible place.

Summary of Changes

This publication contains the following new or updated information. This list includes substantive updates only and is not intended to reflect all changes.

Topic	Page
Added Storage and Handling	7
Updated step 2	9
Updated Table 1	10
Added Table 2	10
Updated Control Units	11
Updated Declaration of Conformity	18

Additional Resources

These documents contain additional information concerning related products from Rockwell Automation. You can view or download publications at rok.auto/literature.

Resource	Description
System Security Design Guidelines Reference Manual, publication SECURE-RM001	Provides guidance on how to conduct security assessments, implement Rockwell Automation products in a secure system, harden the control system, manage user access, and dispose of equipment.
UL Standards Listing for Industrial Control Products, publication CMPNTS-SR002	Assists original equipment manufacturers (OEMs) with the construction of panels, to help verify that they conform to the requirements of Underwriters Laboratories.
American Standards, Configurations, and Ratings: Introduction to Motor Circuit Design, publication IC-AT001	Provides an overview of American motor circuit design that is based on the methods that are outlined in the NEC.
Industrial Components Preventive Maintenance, Enclosures, and Contact Ratings Specifications, publication IC-TD002	Provides a quick reference tool for Allen-Bradley industrial automation controls and assemblies.
Safety Guidelines for the Application, Installation, and Maintenance of Solid-state Control, publication SGI-1.1	Designed to harmonize with NEMA Standards Publication No. ICS 1.1-1987 and provides general guidelines for the application, installation, and maintenance of solid-state control in the form of individual devices or packaged assemblies that incorporate solid-state components.
Industrial Automation Wiring and Grounding Guidelines, publication 1770-4.1	Provides general guidelines for installing a Rockwell Automation industrial system.
Product Certifications website, rok.auto/certifications .	Provides declarations of conformity, certificates, and other certification details.

Notes:

Product Overview

The Safedge™ safety edge system is ideal as a safety sensor in applications such as power operated doors, automated vehicles, and moving machinery beds, for use when you require object detection by touch. The system can provide a continuous line of high sensitivity touch sensing along or around practically anything.

Safety Edge System Description

The Safedge safety edge system consists of up to 50 m (164 ft) of profile, a cable connector, an ending resistor, a C rail, and a control unit. The control unit can monitor lengths of up to 50 m (164 ft). All profiles have the same principle of operation.

This manual covers the use of the parts of the Safedge safety edge system. If you require joints, corners, or further assistance, contact your local Allen-Bradley distributor or Rockwell Automation sales office. Suitably trained and qualified personnel must complete all installation work in accordance with statutory requirements for safety.

Storage and Handling

Storage

Store the Safedge control unit and profiles within the temperature range of -10...+55 °C (-14...+131 °F).

Handling and Transport

Transport the Safedge control unit and profile within the temperature range of -10...+55 °C (-14...+131 °F). Do not subject the control unit to any impact or heavy loads. Use the original packaging to protect the control unit from excessive flexing.



Always unpack carefully and avoid damage that can result from rough handling or the use of knives, box cutters, and so on.

Safedge Selection

The following are the most important factors that influence the selection of a suitable pressure-sensitive edge or pressure-sensitive bar for a specific application.

- Category and Performance Level according to EN ISO 13849-1 as required for the application. These requirements are based on:
 - The risk assessment for the particular application.
 - The requirements of a relevant type-C standard.
- Hazard speed:

The speed at which the hazardous surface moves. Normally, one surface moves and the other is stationary. Consider the maximum possible speed as the hazard speed. If both surfaces move, special consideration is required.
- Stop travel of hazardous parts:

The distance the hazardous surfaces travel after the output signal switching device to the machine control system gives a stop signal. This travel depends on the hazard speed, the response time of the machine control system, and the efficiency of the machine braking system. You can calculate and/or measure this travel. Where appropriate, use a suitable safety factor to account for brake deterioration, measurement tolerances, and so on.
- Recovery of the sensor after deformation:

On applications where the time between successive actuations of the sensor is less than 30 s. Select a sensor that recovers sufficiently for normal operation within the time available.

Selection Procedure

After you decide the category and the Performance Level according to ISO 13849-1, the procedure is as follows.

1. Determine the required operating speed and maximum hazard speed.

Measure or calculate the maximum hazard speed, if the speed is not given. The point in the travel at which the maximum speed occurs depends on the drive mechanism.

The maximum operating speed of the device must be greater than the maximum hazard speed.

2. Determine the required minimum overtravel distance.

Determine the stopping travel of the hazardous parts. Measure or calculate the distance, if the distance is not given. The stop travel multiplied by a suitable safety factor of at least 1; a factor of 2 gives the required minimum overtravel for the application. Where other factors exist, such as a braking system that is subject to deterioration, use a higher safety factor.

A simple way to measure the stop distance is to fit a position detection temporarily at a position close to where the maximum hazard speed occurs. Normally, closed contacts of this position detection must connect into the machine control stop circuit at the point at which the output signal switching devices connect. Run the machine several times in the worst anticipated conditions and measure the distance that is traveled beyond the actuating point of the position detection. The maximum measured distance is the stop distance.

3. Determine the maximum permissible force.

When available, take the maximum permissible force from a type-C standard for the specific machine or in accordance with the risk assessment. The risk assessment must consider the body parts and types of persons to be protected, for example, children or elderly persons. Also consider the speed, shape, and material of the sensor and the maximum pressure that the device exerts. The maximum permissible force must be as low as possible.

4. Select the device.

Select the safeguard with the required maximum operating speed that provides the required minimum overtravel distance before the maximum permissible force is reached. Use the force/distance relationship data or diagrams that the manufacturer provides.

If you cannot find a pressure-sensitive edge or pressure-sensitive bar with sufficient overtravel, improve the stopping performance of the machine.

Components

A Safedge safety edge system consists of pressure-sensitive profiles, which act as sensors, and control units, which evaluate the sensor signal.

Profiles

Table 1 - Profiles

Profile Model No.	Profile
440F-EA <i>b c d e</i>	440F-E0110S
440F-EB <i>b c d e</i>	440F-E0110R
440F-EC <i>b c d e</i>	440F-E0110N
440F-ED <i>b c d e</i>	440F-E0510S
440F-EE <i>b c d e</i>	440F-E1610S
440F-EF <i>b c d e</i>	440F-E1610N
440F-FG <i>b c d e</i>	440F-E0804S
440F-EH <i>b c d e</i>	440F-E0310S
440F-EI <i>b c d e</i>	440F-E0210S
440F-EJ <i>b c d e</i>	440F-E0510S
440F-EK <i>b c d e</i>	440F-E0804S
440F-EL <i>b c d e</i>	440F-E0210S
440F-EM <i>b c d e</i>	440F-E0118S
440F-EN <i>b c d e</i>	440F-E1111S
440F-E0 <i>b c d e</i>	440F-E1111S

- *b* indicates with or without a C rail for mounting.
- *c* indicates the location of the cable entrance.
- *d* indicates the end of the profile and cable length.
- *e* indicates the length of the profile in mm and is a five-digit number.

Table 2 - Profiles - Engineered to Order

Profile Model No.	Profile
440F-ESYS <i>b c d e</i>	Engineered To Order with non-standard shape (square or L-shape) and size
440F-HFSYS <i>b c d e</i>	Engineered To Order with non-standard shape (curved) and size

- *b c d e* indicates an internal reference number to the Engineered To Order project.

IMPORTANT All C rails are supplied without mounting holes. The C rail (Cat. No. 440F-R1212) can be supplied curved to meet most applications.

Each profile uses a combination of non-conductive rubber and a flexible wire-cored conductive rubber, which bonds together to form various energy-absorbing profiles. The profile has no rigid internal parts that can break through or cause fatigue failures after prolonged use. The maximum operating voltage of the profile is 12V DC; operators are therefore not exposed to potentially dangerous voltage if the profile is accidentally cut or sheared. The copper wire core throughout the length of the profile helps maintain that there is no significant build-up of resistance over long lengths.

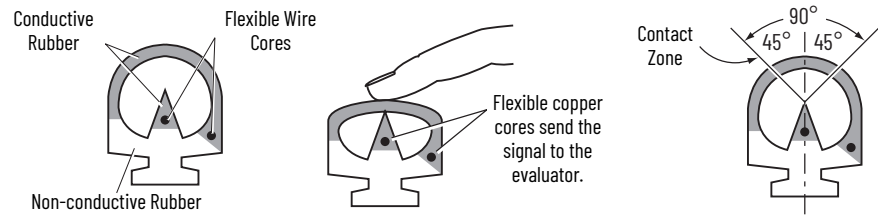
Figure 1 - Profile Operation and Contact Zone

Control Units

Table 3 - Safedge Control Unit Product Selection

Safety Outputs	Auxiliary Outputs	Terminals	Reset Type	Output Monitoring	Mounting	Power Supply	Cat. No.
2 N.O.	1 N.C.	Fixed	Automatic/ manual	See Table 4	DIN rail	24V AC/DC or 110/230V AC ⁽¹⁾	440F-C251D
2 N.O.					Surface	24V AC/DC or 110/230V AC ⁽¹⁾	440F-C251P
1 N.O.					DIN rail	24V AC/DC	440F-C252D

(1) An internal switch changes the operating voltage from 110V AC to 230V AC.

The Safedge control unit monitors the circuit through the profile. When 6k Ω resistance (that is, normal run conditions) is detected, the control unit produces a signal to the machine control circuit. When you press the profile from any direction through 90° as shown in [Figure 1](#), the top conductive rubber strip compresses and touches the middle conductive rubber, which creates a short circuit, which drops the overall resistance. The control unit monitors this action and initiates the machine shutdown. The control unit detects any single fault in the profile or the wiring connections to the profile and outputs go to a safe (off) state.

Individual profiles connect to each other via wires, axial connectors, or standard 90° connectors. Two wires connect the profiles to the control units. The control unit has fully cross-monitored safety relays; you can configure the unit to detect an external contactor fault.

An auxiliary output relay provides a signal about the status of the control unit. Three status indicators show whether the control unit is in the Run, Stop, or Open condition.

Table 4 - Status Indicators

Color	Function
Green	Run
Yellow	Open circuit
Red	Stop

Compliance

The control unit complies with the requirements of EN ISO 13856-2 regarding electrical faults and can be met for the associated part of the machine control system. B10d for profile is 10,000.

Faults are excluded per EN ISO 13849-1.

- Install edges in an environment that does not cause degradation of profile material.
- Properly seal the edges to help prevent non-conductive fluids from filling the profile cavity, which restricts pressing the profile.
- The profile must connect to the qualified controller.

IMPORTANT Special measures are required in the presence of abnormally high levels of EMI. For example, near welding or induction heating equipment, or near radio transmitters or transceivers.



ATTENTION: Because fault exclusion is used, Safedge safety edge systems can achieve up to PLd Cat. 3. You must determine the required PL level. The Safedge safety edge system as installed must meet the required PL level.

Installation of the Safedge Safety Edge System

IMPORTANT Only use cyanoacrylate adhesive. Use Loctite 401 for dry applications. Use Loctite 380E for wet applications.

This type of cyanoacrylate adhesive achieves a lasting sealing and high protection in accordance with the IP65 rating.

Install the C Rail

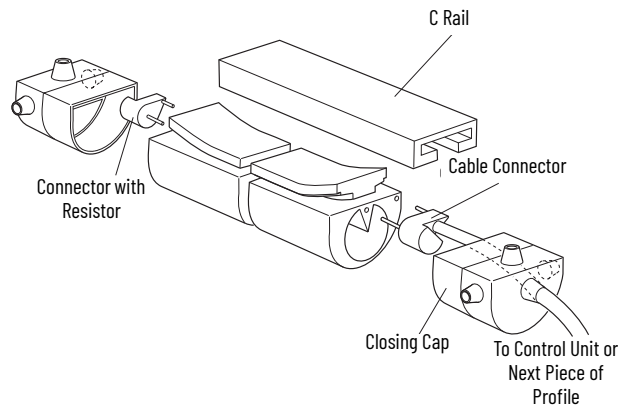

Mount the C Rail

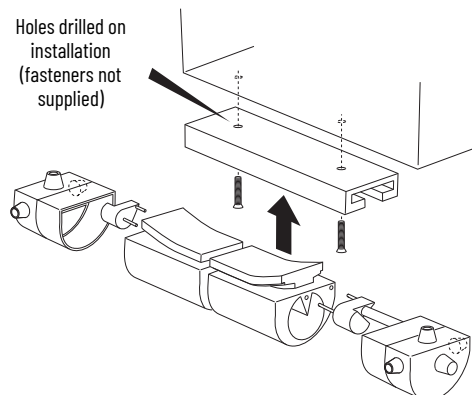

Assemble and Install the Safedge Profile

1. Cut the Safedge profile to length. Cut profiles without the coating chamber with rubber shears. Cut profiles with the coating chamber with a fine tooth saw.

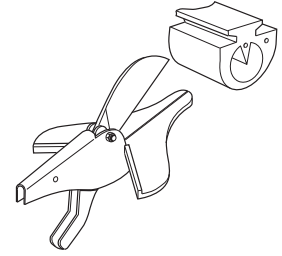

2. When you use the catalog number 440F-A1302 closing cap with sealing lip, cut back the profile base to a length of 12 mm (0.46 in.). Precisely trim off the profile base completely and leave a flush surface.

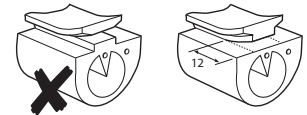

3. Roughen the shaded areas with emery/sand paper.

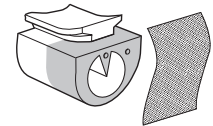

4. The closing caps are molded with four grommets, each with a rubber plug. When you fit a resistor, leave the plugs intact. When you make a cable connection, select the appropriate cable exit, and remove the plug from the grommet with a hole punch.

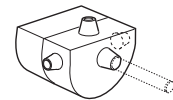

5. Pull the connecting cable through the hole.

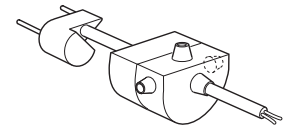

6. Pierce each of the copper wires with one of the needles. Press the needle contacts of the connector in the direction shown: Wedge outwards, straight into the copper wires.

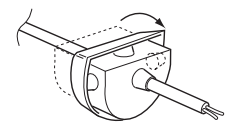
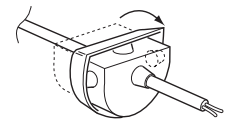

ATTENTION: The narrow side (wedge) of the connector must show outwards.

7. Fold back the sealing lip of the cap, then:
 - a. Apply adhesive to the shaded area of the closing cap as illustrated, then affix to the edge of the profile. Apply pressure for 10 seconds to enable adhesion.
 - b. Apply adhesive to the remainder of the shaded area and allow the sealing lip to contact the profile.

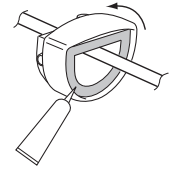

IMPORTANT Spread the adhesive evenly over the shaded area. Verify that no adhesive enters the profile.

8. To achieve a complete seal, apply more adhesive to the Safedge profile, especially around the grommet/cable exit and sealing lip of the closing cap.
9. Use the axial profile connector catalog number 440F-A0061S for extensions and repairs (see [step 1...step 8](#)) for the 440F-E0110 series of profiles only. For other types, use straight pin connectors.

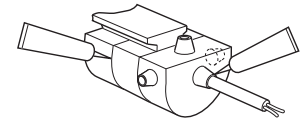

When you insert the profile into the C-rail, use a lubricant to reduce friction. During installation, do not pull on the connecting cable or on the rubber profile.

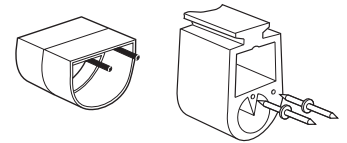

Sensing Surface of Safedge Safety Edge System

The sensing surface of the Safedge safety edge system is active along almost the full length of the edge. The 10 mm (0.4 in.) at the beginning and end are not active.

Catalog number 440F-E1111S is a cover profile only and is non-functioning.

- Maximum speed is 100 mm/s
- Suitable for the detection of fingers

Do not mount the control unit inside the hazard zone. Mount the control unit so it is visible during operation, as access to the control unit is required for manual reset or for routine indicator observation. You can mount the control unit on either side of the power doors, as long as the only hazard is the actual doors. In all other cases, mount the control unit anywhere convenient outside the hazard zone, with consideration for access requirements for test and maintenance.

Force Travel Relationship

Since the Safedge safety edge system is a contact device, a force is required to operate the device. This force depends on the shape of the object that applies the force, the speed of the object, and the deformation distance on the profile. To help understand the force requirements, the European standard ISO 13856-2 2013 provides three test objects that travel at two speeds. [Figure 2](#) shows the force that is applied over the deformation distance on the surface of the profile. The force required to operate the corners is greater than the force required along the straight section of the profile. Use this force as a guideline, as the inanimate object cannot be harmed.

Figure 2 - Force Versus Distance

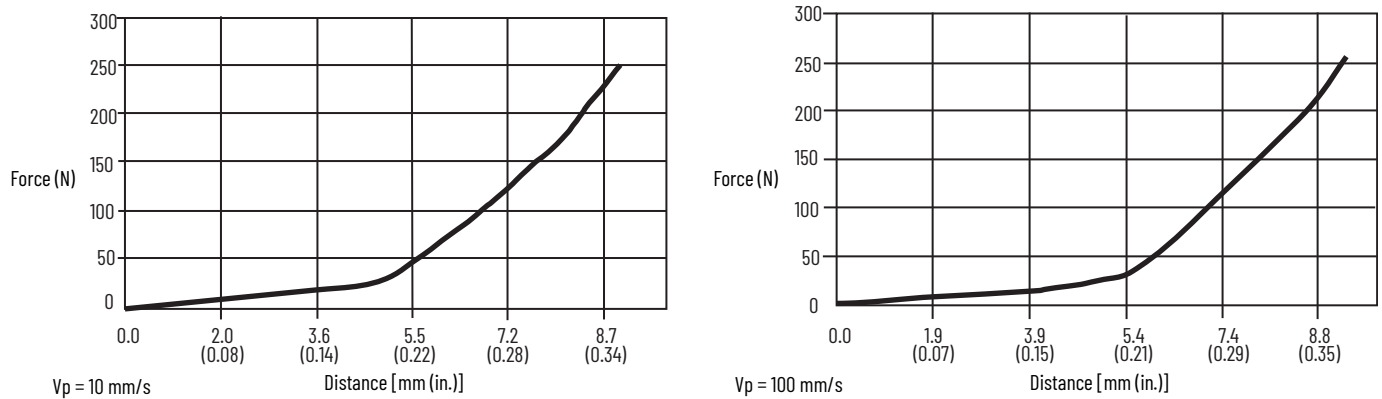

Deformation Travels

Figure 3 - Force/Deformation Path Diagram

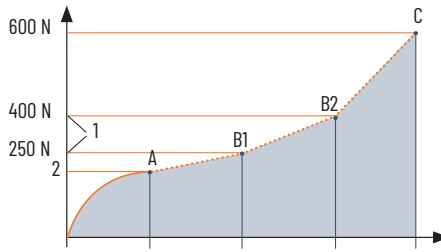

- (1) Threshold forces
- (2) Minimum actuation force

Attribute per Cat. No.	Value		
440F-E010N			
Test temperature 20 °C (68 °F)/speed	10 mm/s	100 mm/s	200 mm/s
Actuation force [N]	36.5	51.4	71.7
Response travel A [mm (in.)]	5.3 (0.21)	5.6 (0.22)	7.4 (0.29)
Total deformations at 250 N B1 [mm (in.)]	9.4 (0.37)	8.9 (0.35)	10.0 (0.39)
Total deformations at 400 N B2 [mm (in.)]	11.4 (0.45)	11.0 (0.43)	11.8 (0.46)
Total deformations at 600 N B2 [mm (in.)]	13.2 (0.52)	12.9 (0.51)	13.7 (0.52)
Compensation travel at 250 N [mm (in.)]	4.1 (0.16)	3.3 (0.13)	2.6 (0.10)
Compensation travel at 400 N [mm (in.)]	6.0 (0.24)	5.4 (0.21)	4.4 (0.17)
Stop distance, max [mm (in.)]	5.0 (0.20)	4.5 (0.18)	3.6 (0.14)
440F-E010R, 440F-E010S, 440F-E0510S			
Test temperature 20 °C (68 °F)/speed	10 mm/s	100 mm/s	200 mm/s
Actuation force [N]	41.7	51.1	60.6
Response travel A [mm (in.)]	5.7 (0.22)	5.8 (0.23)	4.9 (0.19)
Total deformations at 250 N B1 [mm (in.)]	9.5 (0.37)	8.6 (0.34)	7.6 (0.30)
Total deformations at 400 N B2 [mm (in.)]	11.0 (0.43)	10.6 (0.42)	9.3 (0.37)
Total deformations at 600 N B2 [mm (in.)]	13.3 (0.52)	12.6 (0.50)	11.3 (0.44)
Compensation travel at 250 N [mm (in.)]	3.8 (0.15)	2.8 (0.11)	2.6 (0.10)
Compensation travel at 400 N [mm (in.)]	5.3 (0.21)	4.7 (0.19)	4.3 (0.17)
Stop distance, max [mm (in.)]	4.4 (0.17)	3.9 (0.15)	3.6 (0.14)
440F-E1610N, 440F-E0118S			
Test temperature 20 °C (68 °F)/speed	10 mm/s	100 mm/s	200 mm/s
Actuation force	63.6 N	76.9 N	84.6 N
Response travel A [mm (in.)]	9.7 (0.38)	9.6 (0.38)	9.4 (0.37)
Total deformations at 250 N B1 [mm (in.)]	22.3 (0.88)	19.5 (0.77)	18.5 (0.73)
Total deformations at 400 N B2 [mm (in.)]	28.7 (1.13)	27.6 (1.09)	26.7 (1.05)
Total deformations at 600 N B2 [mm (in.)]	31.2 (1.23)	29.9 (1.18)	28.9 (1.14)
Compensation travel at 250 N [mm (in.)]	12.7 (0.50)	9.9 (0.39)	9.1 (0.36)
Compensation travel at 400 N [mm (in.)]	19.1 (0.75)	17.9 (0.70)	17.3 (0.68)
Stop distance, max [mm (in.)]	15.9 (0.63)	15.0 (0.59)	14.4 (0.57)
440F-E1610S, 440F-E0804S			
Test temperature 20 °C (68 °F)/speed	10 mm/s	100 mm/s	200 mm/s
Actuation force	13.5 N	19.5 N	20.6 N
Response travel A [mm (in.)]	7.3 (0.29)	7.2 (0.28)	6.9 (0.27)
Total deformations at 250 N B1 [mm (in.)]	28.1 (1.10)	25.4 (1)	25.4 (1)
Total deformations at 400 N B2 [mm (in.)]	32.4 (1.28)	31.1 (1.22)	30.6 (1.20)
Total deformations at 600 N B2 [mm (in.)]	34.9 (1.37)	33.8 (1.33)	32.9 (1.30)
Compensation travel at 250 N [mm (in.)]	20.8 (0.82)	18.2 (0.72)	18.4 (0.72)
Compensation travel at 400 N [mm (in.)]	25.0 (0.98)	23.9 (0.94)	23.7 (0.93)
Stop distance, max [mm (in.)]	20.8 (0.82)	19.9 (0.78)	19.7 (0.78)

Attribute per Cat. No.	Value		
440F-E0310S, 440F-E0210S			
Test temperature 20 °C (68 °F)/speed	10 mm/s	100 mm/s	200 mm/s
Actuation force	41.6 N	68.5 N	87.0 N
Response travel A [mm (in.)]	6.8 (0.27)	9.6 (0.38)	8.6 (0.34)
Total deformations at 250 N B1 [mm (in.)]	38.1 (1.50)	21.7 (0.85)	22.0 (0.87)
Total deformations at 400 N B2 [mm (in.)]	44.6 (1.76)	44.0 (1.73)	42.5 (1.67)
Total deformations at 600 N B2 [mm (in.)]	49.5 (1.95)	49.2 (1.95)	47.6 (1.87)
Compensation travel at 250 N [mm (in.)]	31.3 (1.23)	12.2 (0.48)	13.4 (0.53)
Compensation travel at 400 N [mm (in.)]	37.8 (1.49)	34.4 (1.35)	33.9 (1.33)
Stop distance, max [mm (in.)]	31.5 (1.24)	28.7 (1.13)	28.3 (1.11)

Select the Cushion Factor

One of the important characteristics of safety edge systems is called the cushion factor. The cushion factor is the distance that you can depress the profile after the signal is generated. This characteristic is important when you mount the profile on automated doors.

Automated doors continue to close for some finite time after the profile sends the initial stop signal, which is known as the system response time. The system response time is the sum of the Safedge control unit response time, the control system response time, and the mechanical stop time. Systems with longer response time must use larger cushion factors. You must confirm that injury does not occur if parts of the body get jammed, for example between the sensing edge and the fixed part of a machine.

Also consider a reversing option. When you depress the profile, the Safedge control unit sends a signal to a reversing relay. Since the reversing relay is not a safety rated device, you must still confirm that injury does not occur if parts of the body get jammed.

Mounting

Figure 4 - Mounting Dimensions [mm (in.)]

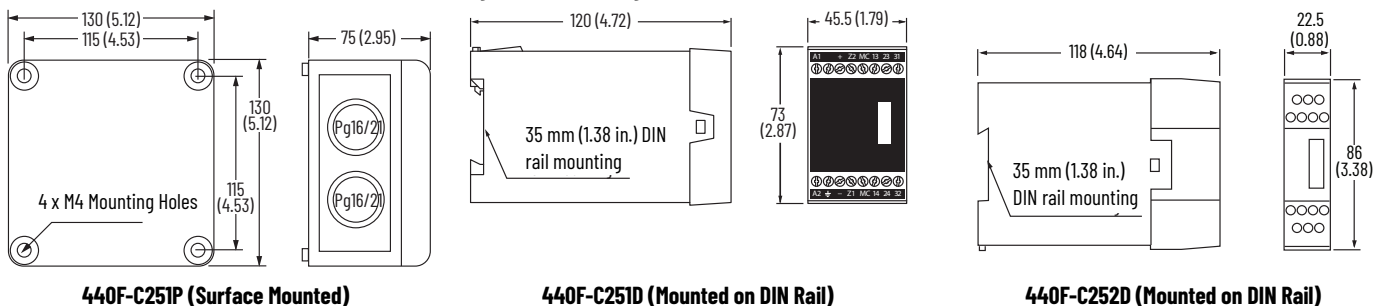

Terminal Connections

To help prevent strain on terminal connections, use connection boxes and coiled cables.

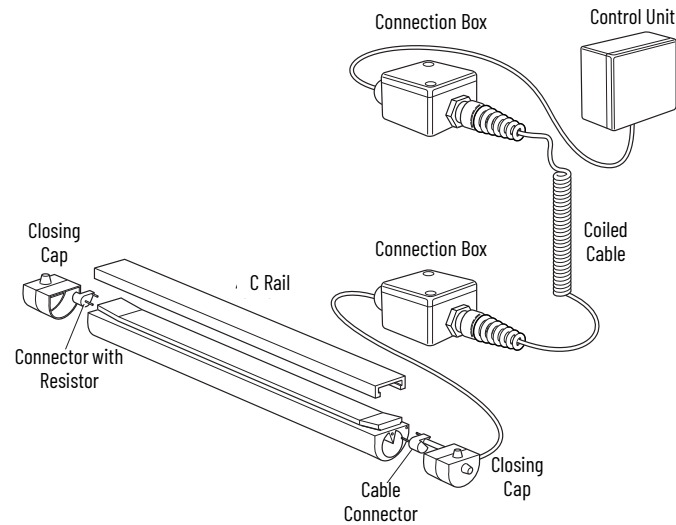

Declaration of Conformity

CE Conformity

Rockwell Automation declares that the products that are shown in this document conform with the 2014/30/EU Electromagnetic Compatibility Directive (EMC) and 2006/42/EC Machinery Directive (MD) and that the respective standards and/or technical specifications have been applied.

For a comprehensive CE certificate, see: rok.auto/certifications.

UKCA Conformity

Rockwell Automation declares that the products that are shown in this document are in compliance with 2016 No. 1091 Electromagnetic Compatibility Regulations and 2008 No. 1597 Supply of Machinery (Safety) Regulations and that the respective standards and/or technical specifications have been applied.

For a comprehensive UKCA certificate, see: rok.auto/certifications.

Installation and Wiring

IMPORTANT Wiring must be in accordance with the [British] National Electric Code and applicable local codes and ordinances. Carefully follow the instructions in [Table 5 on page 20](#) for correct installation.

Electrical Connections

Figure 5 - Safedge Control Unit (See [Table 5 on page 20](#) for Callout Explanations)

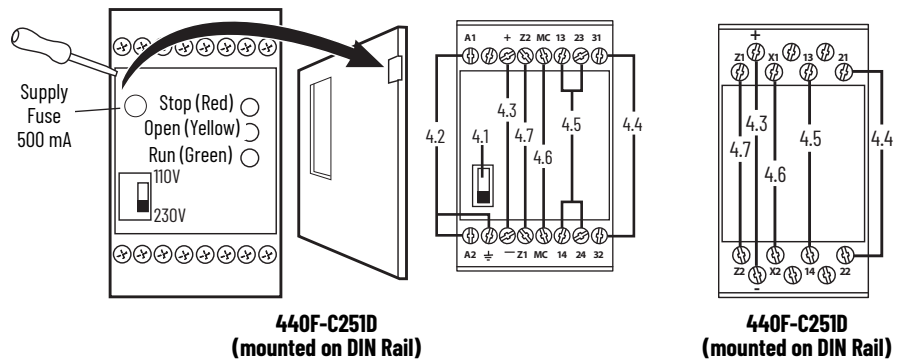
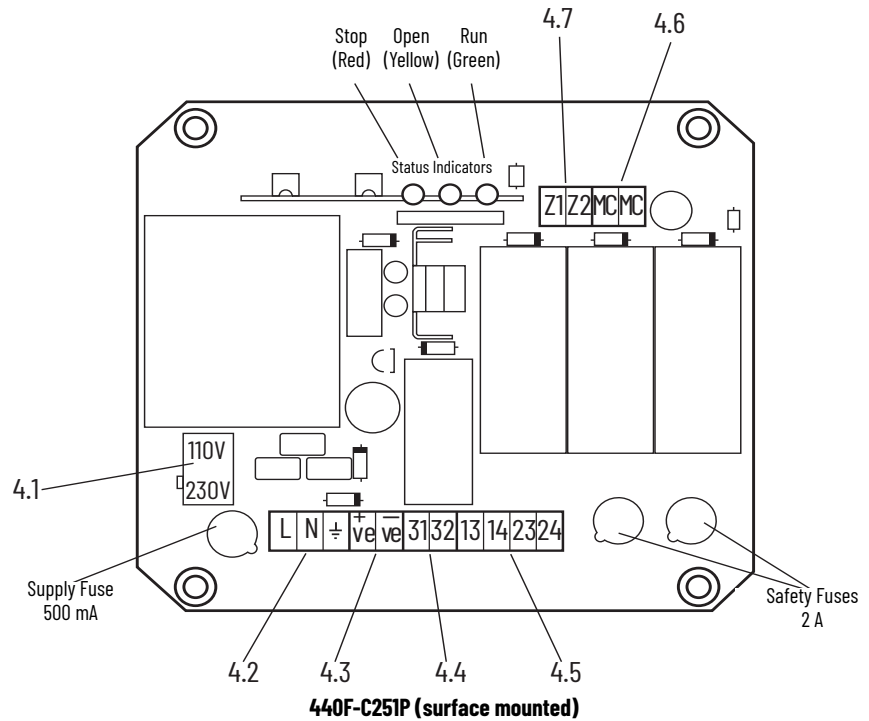

Table 5 - Callout Explanation of [Figure 5 on page 19](#)

Item	Description
4.1	<p>Main selector switch If you use a 110V AC or a 230V AC supply, set the voltage selector switch before you turn on the power. The default factory setting of the unit is 230V AC.</p>
4.2	<p>Main input terminal LN PE (A1, A2, PE) If you use a 110V AC or 230V AC supply, the power supply must be wired together with a protective earth (ground) to the terminals shown. The size of the protective earth (PE, ground) wire must at least be equal to that of the supply wire. Also check the main selector switch. If these terminals are used, ignore the following items.</p>
4.3	<p>24V AC/DC input terminal +ve and -ve or + and - If a 24V AC/DC supply is used, the supply must be connected to these terminals, verifying that the correct polarity is observed. Do not make any connections to the terminals of the main input terminal. When a 24V AC or DC supply is used, it must be isolated from the main supply in accordance with international electrical safety practice (IEC 364-4-41). One pole must be grounded to the earth. For 24V DC, the negative pole must be grounded. With 24V AC, the ground of the power supply must be connected to the negative terminal.</p>
4.4	<p>Aux. Output terminals 31 and 32 or 21 and 22 in 440F-C This terminal provides an auxiliary normally closed contact (that is closed when the green Run status indicator is off) which is suitable for indication or for alarm devices. As it is an auxiliary, it must not be connected to the safety circuit.</p>
4.5	<p>Safety Output terminals 13, 14, 23 and 24 These terminals are volt-free contacts for connection to the machine safety circuits—in other words, they are connected in series with the machine contactor control circuit (max rating 2 A at 250V AC). Both of these safety circuits are internally fused but must also be externally protected with a 2 A quick-acting fuse. If you are using only one contactor, terminals 13 and 24 are required and terminals 14 and 23 must be jumpered together. For two contactors with two independent control circuits (that is a dual-channel system), use 13-14 for one contactor and 23-24 for the other. For two contactors, also see Typical Wiring Diagrams on page 25.</p>
4.6	<p>Reset terminal MC-MC or X1 - X2 on the 440F-C2522 These terminals are used for a number of different functions (the surface mount version is supplied with jumpers, while the DIN rail version is supplied without a jumper). Without the jumper, the terminals can be connected to positively guided normally closed auxiliary contacts on the machine contactors to provide monitoring of the contactors in dual-channel control systems. If one contactor fails to isolate the power at de-energization of its control coil, the Safedge™ safety edge system does not allow the other contactor to be energized until the fault has been rectified. Fit a jumper between these terminals on the DIN rail unit if this function is not required. This terminal is also used for auto/manual reset. If the MC-MC terminal remains jumpered or connected only to the normally closed contact of the contactor, the unit is in Automatic Reset mode. In Automatic Reset mode, the output is achieved solely by removal of the actuating force. The output is also achieved at the powerup of the actuator (when there is no actuation force present). If a spontaneous restart can generate a risk, based on the result of a risk assessment to ISO12100, then this mode must not be used. See IEC60204-1 and EN ISO13849-1. For Manual Reset mode, a normally open spring return (not latching) push button must be connected across the MC-MC terminals or in series with the normally closed contactors. When the actuating force is removed, the unit does not operate until the button is pressed. The button also has to be pressed after powering up the control unit.</p>
4.7	<p>Profile connection to control units These terminals are used to connect the profile to the:</p> <ul style="list-style-type: none"> • Z1 = Brown (inner conductor) • Z2 = White (outer conductor) <p>See Typical Wiring Diagrams on page 25. A profile must end with a 6kΩ resistor (yellow) for series connection. If two profiles connect directly to Z1 and Z2 (in parallel), each profile must end with a 15K resistor (blue).</p>

Profile Connection

Connect in Series

Installations that involve several profiles are normally connected in series.

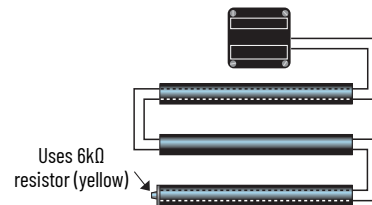

Connect in Parallel

A maximum of two profiles can connect in parallel to facilitate the wiring of certain applications.



Notes:

Commissioning and Sequence of Operation

When you install the unit, check the following sequence of operation.

Manual Reset Mode

1. Turn on the power.
 - a. No status indicators illuminate.
2. Press the reset switch.
 - a. The green Run status indicator illuminates.
 - b. Safety contacts close.
 - c. Auxiliary contacts open.
 - d. Contactors energize.
3. Press the profile.
 - a. The green Run status indicator turns off.
 - b. The red Stop status indicator illuminates.
 - c. Safety contacts open.
 - d. Auxiliary contacts close.
 - e. Contactors de-energize.
4. Release the profile.
 - a. The red Stop status indicator turns off.
 - b. System returns to [step 1](#).
5. If profile is pressed before reset:
 - a. The red Stop status indicator illuminates each time that you press the profile but the safety contacts do not energize.

Automatic Reset Mode

1. Turn on the power.
 - a. The green Run status indicator illuminates.
 - b. Safety contacts close.
 - c. Auxiliary contacts open.
 - d. Contactors energize.
2. Press the profile.
 - a. The green Run status indicator turns off.
 - b. The red Stop status indicator illuminates.
 - c. Safety contacts open.
 - d. Auxiliary contacts close.
 - e. Contactors de-energize.
3. Release the profile.
 - a. System returns to [step 1](#).

-
- IMPORTANT**
- Terminal block torque rating is 0.79 N•m (7 in•lb), suitable for wire sizes 1.5 mm² (16 AWG).
 - Use 1.5 mm² (16 AWG) minimum.
 - Use copper conductors only.
 - Temperature rating of field wiring must not be less than ambient.
-

Comparative Properties

Property	NBR/CR Profiles 440F-E010N, 440F-E1610N	EPDM Profiles 440F-E0110S, 440F-E0110R, 440F-E0510S, 440F-E1610S, 440F-E0804S, 440F-E0310S, 440F-E0210S, 440F-E0118S
Tensile strength (reinforced) mPA	26	20
Resilience (20 °C [68 °F])	Fair	Good
Low temperature flexibility	Fair	Good
Resistance to sunlight	Good	Good
Resistance to heat aging	Good	Good
Resistance to oxidation	Fair	Good
Resistance to ozone	Fair	Good
Resistance to H ₂ O	Good	Good
Resistance to dilute acids	Fair	Good
Resistance to concentrated acids	Fair	Good
Resistance to oils and greases	Good	Poor

Catalog number 440F-E1111S is a cover profile only and is non-functioning.

-
- IMPORTANT** Select the profile according to the intended environment.
-

Typical Wiring Diagrams

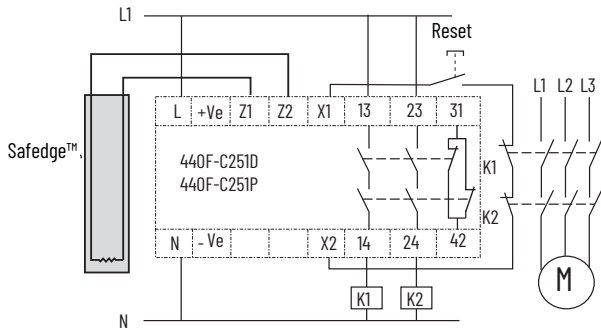

Series End, Safedge Input, Manual Reset, Dual-channel Output, Monitored Output

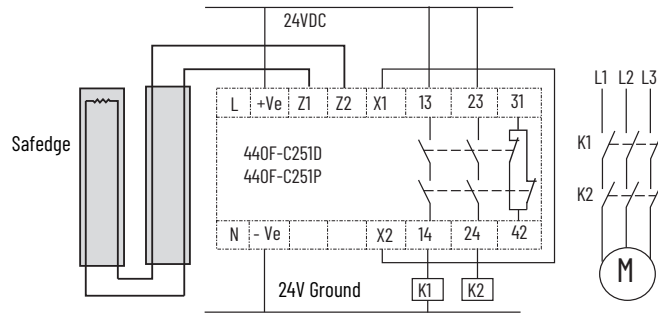

Series End, Cascaded, Safedge Input, Automatic Reset, Dual-channel Output, No Output Monitoring

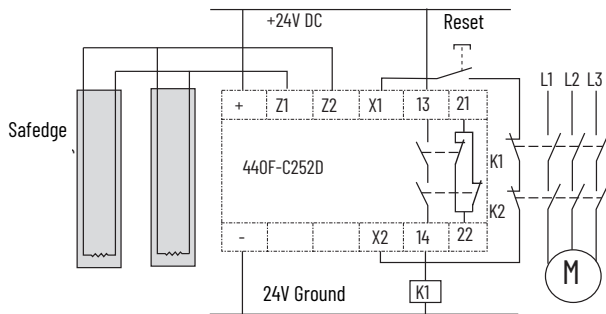

Parallel End, Safedge Input, Manual Reset, Single-channel Output, Monitored Output

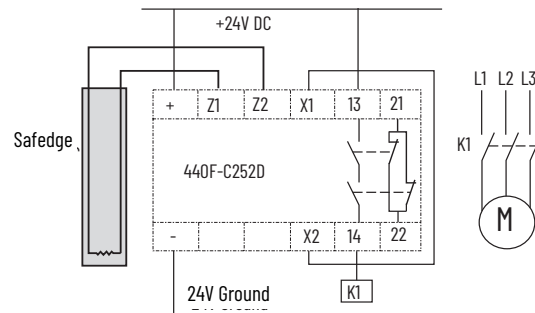

Series End, Safedge Input, Automatic Reset, Single-channel Output, No Output Monitoring

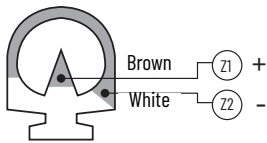

The wiring diagram on the left shows a 110/230V AC application with one contactor (with profile pressed). The right side of this illustration shows a 110/230V AC application with two contactors, contactor monitoring and Start/Stop circuit (also with profile pressed).

Notes:

Maintenance and Service

Troubleshooting

Symptom	Probable Cause	Check
The yellow Open status indicator illuminates.	Open circuit in the profile or the connecting wiring.	<ul style="list-style-type: none"> Verify that Z1-Z2 terminals are secure. Check the cable for breaks. Check the profile for damage.
No status indicators illuminate even if profile is pressed.	Supply failure.	<ul style="list-style-type: none"> Confirm that the voltage selector switch is set correctly. Check the supply fuse. Verify that the supply voltage is present.
No status indicators illuminate unless the profile is pressed and then the red Stop status indicator illuminates.	Failure to reset.	<ul style="list-style-type: none"> If you use contactor monitoring, verify that each contactor functions correctly. Confirm that MC-MC terminals are secure. Check that the link is in place and that the Reset button functions correctly.
The unit appears to work correctly but there is no output.	<ul style="list-style-type: none"> Blown fuse. Damaged or incorrect wiring. Fault on Safedge™ causes the outputs to fail-safe. 	<ul style="list-style-type: none"> Check the output fuses. Inspect all wiring for damage. Check for movement on any internal relays. Replace the controller.
The machine does not stop when the profile is pressed. The green Run status indicator turns off.	Incorrect external connections	Inspect all wiring to contactors for mistakes.
The machine does not stop when the profile is pressed. The green Run status indicator stays on.	Do not allow the use of the machine. Replace the controller.	

Maintenance

Carefully read this section in full before you attempt any maintenance work.



ATTENTION: During maintenance operations, disconnect the prime mover of the machine before you work on the Safedge safety edge system. Observe all applicable electrical safety precautions.

Profile Cleaning

Keep the profiles clean of deposits such as swarf (fine metallic filings or shavings that are removed by cutting, grinding, or any other mechanical process), debris, and other foreign materials to help prevent damage or dead-zones. Use warm water and a mild detergent to clean the surface area.

Routine Maintenance Inspection and Test

Perform this inspection and test weekly or after repair.

IMPORTANT Do not use solvents.

1. Stop the machine, clean the profile or profiles and allow them to dry off. Inspect the surface of the profile for damage. Any damage that punctures the profile can let material or liquid in. Correct the fault immediately.
2. Check that all end caps, corners, and joints are secure and free from damage. Replace damaged parts immediately.
3. Test the profile operation. Two people are required, one to press the profile and one to observe the operation of the control unit. On safety edge systems that use Manual Reset mode, you must press the Reset button continuously. Check that the green Run status indicator illuminates when the profile is not pressed and that the red Stop status indicator illuminates when it is. Start the machine, press the profile and check that the machine stops immediately.

If these checks reveal any problem, do not allow use of the machine until you rectify the problems. Record all inspections and tests in a written log.

Thorough Examination and Test

Perform this examination and test twice yearly or after repair.



ATTENTION: Suitably trained and qualified personnel are required for this examination and test.

1. Conduct tests as listed in [Routine Maintenance Inspection and Test](#).
2. Isolate the power source to the machine and Safedge safety edge system. Observe usual electrical safety precautions.
3. Inspect the profile and components thoroughly for mechanical damage.
4. Disconnect the wires to the profile at terminals Z1-Z2.
5. Connect the wires from the profile to the input of an ohmmeter. One person must press the profile with one hand at every point on the strip. The resistance must measure $6k\Omega \pm 10\%$ when the profile is not pressed, and no greater than 1K when it is.

If these checks reveal any problems, do not allow the use of the machine until you rectify the problems.

Record the inspection and test in a written log (see [Written Log on page 34](#)).

Repair

Before you work on a Safedge safety edge system or machine control system, isolate the power source to the machine and Safedge safety edge system. Observe all applicable electrical safety precautions.

User repairs are limited to replacement with new Safedge safety edge system parts. If problems occur, return the units to your local Allen-Bradley distributor or Rockwell Automation sales office.

Use heat shrink butt splice connectors when you make any heat shrink butt splice connectors.

After you replace any part of the safety edge system, conduct the inspection and test procedures that are detailed in the [Routine Maintenance Inspection and Test](#) and [Thorough Examination and Test on page 28](#), give special attention to the replacement parts.

IMPORTANT Tampering with component parts invalidates warranty. Warranty is invalid if the quality seal is broken on the DIN rail (Cat. No. 440F-C251D) control unit.

IMPORTANT After maintenance or repair operations, you must correctly refit all fastenings, cable protection, and so on. Failure to do so, or the use of non-approved parts, can result in the Safedge safety edge system failing to achieve its specified performance.

Notes:

Specifications

Control Unit Specifications

Attribute	440F-C251P Surface Mount	440F-C251D DIN Rail	440F-C252D DIN Rail
Conformity	EN ISO 13849-1 PLd, Cat. 3, EN ISO 13856-2		
System response time	13 ms		
Environmental protection	IP65	<ul style="list-style-type: none"> Enclosure: IP40 DINO470 Terminals: IP20 DINO470 	
Safedge profile voltage, max	12V DC (open circuit)		
Operating voltage, nom	4V (run condition)		
Output fuse, max	2 A quick acting		5 A quick acting
Impulse withstand voltage	2500V		
Over voltage	Category 2		
Contamination level	III		
Switched current/voltage, min	10 mA/10V		
Power consumption	< 6VA		
Relay outputs	<ul style="list-style-type: none"> 2 x independent volt free N.O. safety contacts 1 x volt free N.C. auxiliary contact ⁽¹⁾ 		<ul style="list-style-type: none"> 1 x independent volt free N.O. safety contacts 1 x volt free N.C. auxiliary contact ⁽¹⁾
Utilization category	<ul style="list-style-type: none"> AC - 15; 2 A / 250V DC DC - 13; 2 A / 30V DC 		
Safety inputs	Safedge profile (open resistance 6kΩ)		
Status indicators	<ul style="list-style-type: none"> 1 - Green: Run 2 - Yellow: Open 3 - Red: Stop 		
Internal controls	AC voltage selector		
Internal fuses	2 A safety fuses, replaceable (2 off); 500 mAAT supply fuse, replaceable (1 off)	500 mAAT supply fuse (reset ability) (1 off)	
Output fuse, max	—		<ul style="list-style-type: none"> AC: 4 A DC: 2 A
Ambient temperature [°C (°F)]	<ul style="list-style-type: none"> Control unit: -10...+55 (-14...+131) Profile: -5...+55 (23...131) EPDM (ethylene propylene diene modified rubber) <ul style="list-style-type: none"> Excluding 110 N and 01610N: 0...55 (32...131) NBR/CR (acrylonitrile [34% nitrile] butadiene rubber/chloroprene rubber) 		
Humidity	Up to 90% RH at 55 °C (131 °F).		
Vibration	Tested in accordance with IEC 68-2-6, frequency range 10...55 Hz, displacement 0.15 mm (0.01 in.), 10 cycles per axis, sweep rate 1 octave per minute		
MC-MC contactor monitor loop	N.C. (normally closed) contactor loop		
Conductor size, max	<ul style="list-style-type: none"> 1 x 1 sq. mm (0.001 sq in.) stranded with sleeves stripped 5 mm (0.2 in.) 1 x 1.5 sq. mm (0.002 sq in.) solid conductor 		<ul style="list-style-type: none"> 1 x 2.5 sq. mm (0.004 sq in.) stranded with sleeves stripped 8 mm (0.31 in.) 1 x 4 sq. mm (0.006 sq in.) solid conductor
Terminals	Minus terminal screws M2 spring action		Plus-minus terminal screws M3.5 with self-lifting connection, washer terminal boards separately removable
Installation group	C, in accordance with VDE 0110.		
Material	Control unit: Polycarbonate		
Mounting details	4 x M4 holes	45 mm (1.77 in.) DIN rail	22.5 mm (0.89 in.) DIN rail
Housing [mm (in.)]	<ul style="list-style-type: none"> Depth: 75 (2.95) Height: 130 (5.12) Width: 130 (5.12) 		<ul style="list-style-type: none"> Depth: 120 (4.72) Height: 73 (2.87) Width: 45.5 (1.79) 16 way
Weight [g (oz)]	650 (22.9)		450 (14.1)
Miscellaneous	The Safedge profile must end with a 6kΩ resistor.		
Bend radius, min	500 mm (19.8 in.)		

(1) Do not use auxiliary for safety.

Table 6 - Profile Specifications

Attribute	440F-E0110N	440F-E0510S 440F-E0110R 440F-E0110S	440F-E0210S 440F-E0310S	440F-E1610N 440F-E0118S	440F-E0804S 440F-E1610S
Actuation distance [mm (in.)]	6.4 (0.25)	6.6 (0.26)	8.0 (0.31)	7.8 (0.30)	9.4 (0.37)
Response distance [mm (in.)]	1.2 (0.05)	1.9 (0.07)	27.2 (1.07)	8.4 (0.33)	5.0 (0.20)

Safedge Profiles

Table 7 - Profile Approximate Dimensions

Cat. No.	Diagram [mm (in.)]	Cushion Factor [mm (in.)]	Level of Protection	Actuation Angle	Weight [kg/m (lb/ft)]
440F-E0110S 440F-E0110R ⁽¹⁾ 440F-E0110N ⁽²⁾		5 (0.20)	IP67	±20°	0.501 (0.031)
440F-E1610S 440F-E1610N ⁽²⁾		19 (0.75)	IP67	±45°	0.782 (0.048)
440F-E0310S		41 (1.60)	IP67	±45°	1.198 (0.074)
440F-E0510S		5 (0.20) ⁽³⁾	IP67	±45°	0.596 (0.037)
440F-E0804S		19 (0.75) ⁽³⁾	IP67	±45°	0.972 (0.060)

Table 7 - Profile Approximate Dimensions (Continued)

Cat. No.	Diagram [mm (in.)]	Cushion Factor [mm (in.)]	Level of Protection	Actuation Angle	Weight [kg/m (lb/ft)]
440F-E0210S		41 (1.60) ⁽³⁾	IP67	±45°	1.288 (0.080)
440F-E0118S		3.75 (0.15)	IP67	±45°	0.259 (0.016)
440F-E1111S		Cover profile only, non-functioning			0.300 (0.018)

- (1) Red profile.
- (2) Increased resistance to oil (NBR).
- (3) With sealing lip.

Table 8 - C Rail Approximate Dimensions

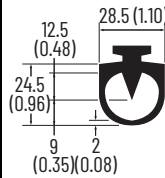
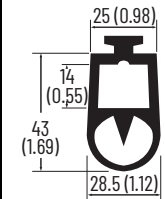
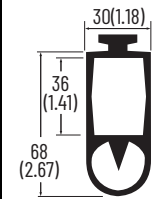
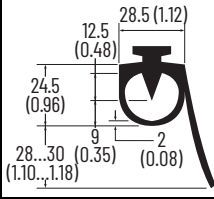
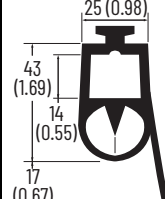
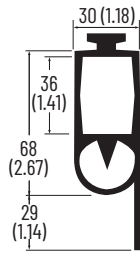
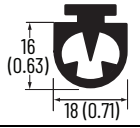
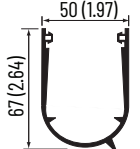
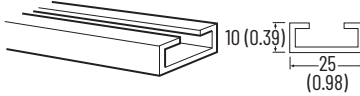
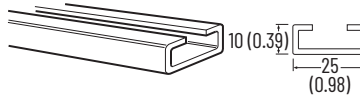
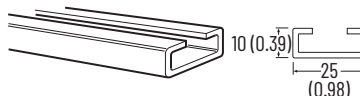
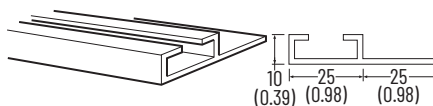
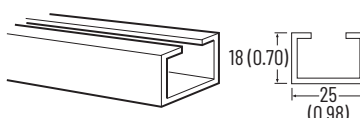
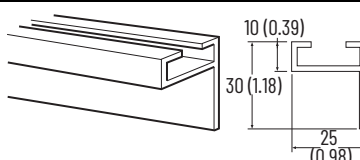
Cat. No.	Diagram [mm (in.)]	Material	Use Case
440F-R1212		Aluminum C112/A	Suitable for attaching all Safedge profiles.
440F-R1112		Zinc-coated steel C112/S	Suitable for attaching all Safedge profiles.
440F-R1212PB		Black PVC C112/PB	Suitable for attaching all Safedge profiles.
440F-R1212PR		Red PVC C112/PR	
440F-R1212PY		Yellow PVC C112/PY	
440F-R1215		Aluminum C112/A3	Ideal when external mounting of C rail is required. Accepts all profiles.
440F-R1216		Aluminum C112/A4	This deeper rail allows cables to run through the channel under the Safedge profile. Accepts all profiles.
440F-R1214		Aluminum C112/A2	Ideal when external mounting of C rail is required. Accepts all profiles.

Rockwell Automation Support

Use these resources to access support information.

Technical Support Center	Find help with how-to videos, FAQs, chat, user forums, Knowledgebase, and product notification updates.	rok.auto/support
Local Technical Support Phone Numbers	Locate the telephone number for your country.	rok.auto/phonesupport
Technical Documentation Center	Quickly access and download technical specifications, installation instructions, and user manuals.	rok.auto/techdocs
Literature Library	Find installation instructions, manuals, brochures, and technical data publications.	rok.auto/literature
Product Compatibility and Download Center (PCDC)	Download firmware, associated files (such as AOP, EDS, and DTM), and access product release notes.	rok.auto/pcdc

Documentation Feedback

Your comments help us serve your documentation needs better. If you have any suggestions on how to improve our content, complete the form at rok.auto/docfeedback.

Waste Electrical and Electronic Equipment (WEEE)







At the end of life, this equipment should be collected separately from any unsorted municipal waste.

Rockwell Automation maintains current product environmental compliance information on its website at rok.auto/pec.

Allen-Bradley, expanding human possibility, Guardmaster, Rockwell Automation, and Safedge are trademarks of Rockwell Automation, Inc.

Trademarks not belonging to Rockwell Automation are property of their respective companies.

Rockwell Otomasyon Ticaret A.Ş. Kar Plaza İş Merkezi E Blok Kat:6 34752, Çerenköy, İstanbul, Tel: +90 (216) 5698400 EEE Yönetmeliğine Uygundur

Connect with us.    

rockwellautomation.com — expanding **human possibility**[®]

AMERICAS: Rockwell Automation, 1201 South Second Street, Milwaukee, WI 53204-2496 USA, Tel: (1) 414.382.2000, Fax: (1) 414.382.4444

EUROPE/MIDDLE EAST/AFRICA: Rockwell Automation NV, Pegasus Park, De Kleetlaan 12a, 1831 Diegem, Belgium, Tel: (32) 2663 0600, Fax: (32) 2 663 0640

ASIA PACIFIC: Rockwell Automation SEA Pte Ltd, 2 Corporation Road, #04-05, Main Lobby, Corporation Place, Singapore 618494, Tel: (65) 6510 6608, FAX: (65) 6510 6699

UNITED KINGDOM: Rockwell Automation Ltd., Pitfield, Kiln Farm, Milton Keynes, MK11 3DR, United Kingdom, Tel: (44)(1908) 838-800, Fax: (44)(1908) 261-917



31611