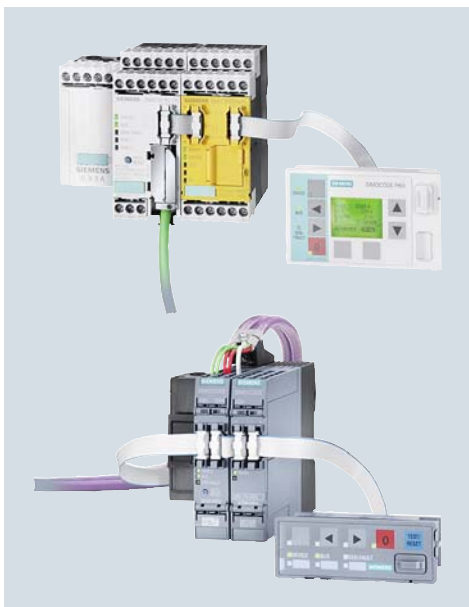

Monitoring and Control Devices

**NEW**

Click on the Article No. in the catalog PDF to access it in the Industry Mall and get all related information.

Article-No.

3RA1943-2C
3RA1943-2B
3RA1953-2B
3RA1953-2N



Or directly in the Internet, e. g.
www.siemens.com/product?3RA1943-2C

Notes:

- 3RT191. function modules can be found
- in the catalog Add-On IC 10 AO · 2015 at the Information and Download Center
- in the interactive catalog CA 01
- in the Industry Mall

Conversion tool
 e.g. from 3UG3 to 3UG4, see
www.siemens.com/sirius/conversion-tool

1) See Catalog ST 70 "Products for Totally Integrated Automation".

	Price groups	PG 200, 2SP, 401, 470, 41B, 41E, 41F, 41H, 41L, 42C, 42F, 42J, 5K1, 5P1
10/2	Introduction	
	SIMOCODE 3UF motor management and control devices	
	<u>SIMOCODE pro 3UF7</u>	
10/5	General data	
10/14	Basic units NEW	
10/16	Expansion modules NEW	
10/18	Fail-safe expansion modules	
10/19	Accessories	
10/28	<u>3UF18 current transformers for overload protection</u>	
ST 70	LOGO! logic modules¹⁾	
10/29	General data	
10/30	LOGO! Modular basic versions	
10/31	SIPLUS LOGO! Modular basic versions NEW	
10/32	LOGO! Modular pure versions	
10/33	SIPLUS LOGO! Modular pure versions	
10/34	LOGO! Modular expansion modules	
10/35	SIPLUS LOGO! Modular expansion modules	
10/36	LOGO! CM EIB/KNX communication modules	
10/37	LOGO! CSM unmanaged	
10/38	AS-Interface connections for LOGO!	
10/39	Accessories	
Ch. 15	LOGO!Power	
10/40	LOGO!Contact	
10/41	LOGO! Software	
	Relays	
	<u>Timing relays</u>	
10/42	General data	
10/43	SIRIUS 3RP25 timing relays, 17.5 mm and 22.5 mm NEW	
10/60	SIRIUS 3RP20 timing relays, 45 mm	
10/66	7PV15 timing relays in enclosure, 17.5 mm	
Ch. 3	SIRIUS 3RA28 function modules for 3RT2 contactors and 3RH2 contactor relays	
Ch. 3	SIRIUS 3RA28 time-delayed auxiliary switches for mounting onto 3RT2 contactors	
10/72	SIRIUS 3RT19 timing relays for mounting onto 3RT1 contactors	
Ch. 3	SIRIUS 3RT19 time-delayed auxiliary switches for mounting onto 3RT1 contactors	
	<u>SIRIUS 3RR21, 3RR22 monitoring relays for mounting onto 3RT2 contactors NEW</u>	
10/76	General data	
10/79	Current and active current monitoring	
	<u>SIRIUS 3RR24 monitoring relays for mounting onto 3RT2 contactors for IO-Link NEW</u>	
10/85	General data	
10/89	Current and active current monitoring	
	<u>SIRIUS 3UG45, 3UG46 monitoring relays for stand-alone installation</u>	
10/94	General data	
10/97	Line monitoring	
10/102	Voltage monitoring	
10/105	Current monitoring	
10/108	Power factor and active current monitoring	
	Residual current monitoring NEW	
10/111	- Residual-current monitoring relays	
10/114	- 3UL23 residual-current transformers	
	Insulation monitoring	
10/115	- General data	
10/117	- For ungrounded AC networks	
10/120	- For ungrounded DC and AC networks	
	Level monitoring	
10/125	- Level monitoring relays	
10/128	- Level monitoring sensors	
10/129	Speed monitoring	
10/132	Accessories	
	<u>SIRIUS 3UG48 monitoring relays for stand-alone installation for IO-Link NEW</u>	
10/133	General data	
10/137	Line monitoring	
10/140	Voltage monitoring	
10/143	Current monitoring	
10/146	Power factor and active current monitoring	
	Residual current monitoring	
10/150	- Residual-current monitoring relays	
10/153	Speed monitoring	
10/156	Accessories	
	<u>SIRIUS 3RS10, 3RS11, 3RS20, 3RS21 temperature monitoring relays</u>	
10/157	General data	
10/161	Relays, analogically adjustable for 1 sensor	
10/164	Relays, digitally adjustable for 1 sensor	
10/167	Relays, digitally adjustable for up to 3 sensors	
10/169	Accessories	
	<u>SIRIUS 3RS14, 3RS15 temperature monitoring relays for IO-Link NEW</u>	
10/170	General data	
10/176	Relays, digitally adjustable for 1 sensor	
10/179	Relays, digitally adjustable for up to 3 sensors	
10/181	Accessories	
	<u>SIRIUS 3RN1 thermistor motor protection</u>	
10/182	For PTC sensors	
	<u>Coupling relays & interface converters</u>	
Ch. 15	Coupling relays	
Ch. 4	Power relays/miniature contactors	
10/191	SIRIUS 3RS17 interface converters	

Monitoring and Control Devices

Introduction

Overview



Type	SIMOCODE pro C	SIMOCODE pro S	SIMOCODE pro V/ SIMOCODE pro V PROFINET	Page
SIMOCODE 3UF motor management and control devices				
Basic units	✓	✓	✓	10/14
Current measuring modules	✓	✓	✓	10/15
Current/voltage measuring modules	--	--	✓	10/15
Decoupling modules	--	--	✓	10/15
Operator panels	✓	✓	✓	10/15
Operator panels with display	--	--	✓	10/15
Expansion modules	--	✓	✓	10/16
Fail-safe expansion modules	--	--	✓	10/18
Current transformers	✓	✓	✓	10/28
SIMOCODE ES (TIA Portal)	✓	✓	Available soon	10/22
SIMOCODE ES 2007	✓	✓	✓	10/24
SIMOCODE pro block library for SIMATIC PCS 7	✓	Available soon	✓	10/26

✓ Available

-- Not available



Type	Basic units	Expansion modules	Software	Page
LOGO! logic modules				
LOGO! Modular basic versions	✓	--	--	10/30
SIPLUS LOGO! Modular basic versions ¹⁾	✓	--	--	10/31
LOGO! Modular pure versions	✓	--	--	10/32
SIPLUS LOGO! Modular pure versions ¹⁾	✓	--	--	10/33
LOGO! Modular expansion modules	--	✓	--	10/34
SIPLUS LOGO! Modular expansion modules ¹⁾	--	✓	--	10/35
LOGO! CM EIB/KNX communication modules	--	✓	--	10/36
LOGO! CSM unmanaged	--	✓	--	10/37
AS-Interface connections for LOGO!	--	✓	--	10/38
LOGO!Contact	--	✓	--	10/40
LOGO! Software	--	--	✓	10/41

✓ Corresponds to

-- Does not correspond to

¹⁾ Devices with extended temperature range and medial loading.



Type Page	3RP25 10/43	3RP20 10/60	7PV15 10/66	3RT19 10/72
Timing relays				
Enclosure:				
• 17.5 mm industry and household equipment installation	✓	--	✓	--
• 22.5 mm industry	✓	--	--	--
• 45 mm industry	--	✓	--	--
• For contactor sizes S0 to S12	--	--	--	✓
Monofunction	✓	✓	✓	✓
Multifunction	✓	✓	✓	--
Monovoltage	--	--	--	✓
Combination voltage	✓	✓	✓	--
Wide voltage range	✓	✓	✓	--
Application:				
• Control systems and mechanical engineering	✓	✓	✓	✓
• Infrastructure	--	--	✓	--
• Mounting onto contactors	--	--	--	✓
✓ Corresponds to or possible -- Does not correspond to or not possible				



Type	3UG451., 3UG461.	3UG463.	3RR21, 3RR22, 3UG4621, 3UG4622	3UG4641	3UG4625 with 3UL23	3UG458.	3UG4501	3UG4651	Page
Monitoring relays									
Line monitoring	✓	--	--	--	--	--	--	--	10/97
Voltage monitoring	--	✓	--	--	--	--	--	--	10/102
Current monitoring	--	--	✓	--	--	--	--	--	10/79, 10/105
Active current monitoring	--	--	3RR22 ✓	✓	--	--	--	--	10/79, 10/108
Power factor monitoring	--	--	--	✓	--	--	--	--	10/108
Residual current monitoring	--	--	--	--	✓	--	--	--	10/111
Insulation monitoring	--	--	--	--	--	✓	--	--	10/117, 10/120
Level monitoring	--	--	--	--	--	--	✓	--	10/125
Speed monitoring	--	--	--	--	--	--	--	✓	10/129
✓ Available -- Not available									

Monitoring and Control Devices

Introduction

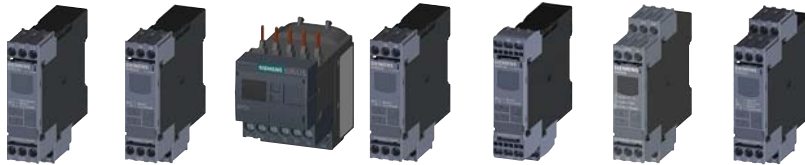

Type	3UG481.	3UG4832	3RR24	3UG4822	3UG4841	3UG4825 with 3UL23	3UG4851	Page
Monitoring relays for IO-Link								
Line monitoring	✓	--	--	--	--	--	--	10/137
Voltage monitoring	--	✓	--	--	--	--	--	10/140
Current monitoring	--	--	✓	✓	--	--	--	10/89, 10/143
Power factor and active current monitoring	--	--	✓	--	✓	--	--	10/89, 10/146
Residual current monitoring	--	--	--	--	--	✓	--	10/150
Speed monitoring	--	--	--	--	--	--	✓	10/153
✓ Available -- Not available								

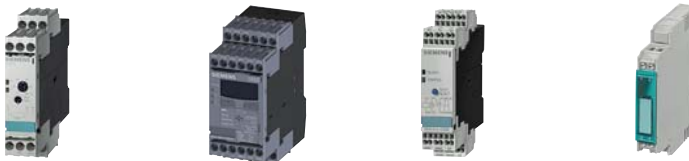

Type	3RS10, 3RS11, 3RS20, 3RS21	3RS14, 3RS15	3RN1	3RS17	Page
Temperature monitoring relays					
Temperature monitoring	✓	--	--	--	10/161, 10/164, 10/167
Temperature monitoring relays for IO-Link					
Temperature monitoring for IO-Link	--	✓	--	--	10/176, 10/179
Thermistor motor protection					
Thermistor motor protection	--	--	✓	--	10/182
Interface converters					
Interface converters	--	--	--	✓	10/191
✓ Available -- Not available					

Connection methods

The monitoring and control devices are available with screw or spring-type terminals.

 Screw terminals

 Spring-type terminals

The terminals are indicated in the corresponding tables by the symbols shown on orange backgrounds.

"Increased safety" type of protection EEx e/d according to ATEX directive 94/9/EC

The communication-capable, modularly designed SIMOCODE pro motor management system (SIRIUS Motor Management and Control Devices) protects motors of types of protection EEx e and EEx d in potentially explosive areas.

ATEX approval for operation in areas subject to explosion hazard

The SIRIUS 3RN1 thermistor motor protection relay for PTC sensors is certified according to ATEX Ex II (2) G and D for environments with explosive gas or dust loads.

The SIRIUS SIMOCODE pro 3UF7 motor management system is certified for the protection of motors in areas subject to explosion hazard according to

- ATEX Ex I (M2); equipment group I, category M2 (mining)
- ATEX Ex II (2) GD; equipment group II, category 2 in area GD.

Overview

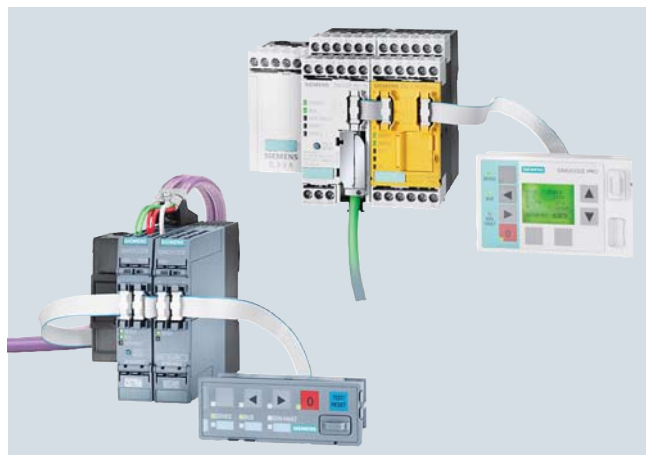

SIMOCODE pro S for efficient entry into motor management and SIMOCODE pro V for maximum functionality

SIMOCODE pro is a flexible, modular motor management system for motors with constant speeds in the low-voltage performance range. It optimizes the connection between I&C and motor feeder, increases plant availability and allows significant savings to be made for installation, commissioning, operation and maintenance of a system.

When SIMOCODE pro is installed in the low-voltage switchboard, it is the intelligent interface between the higher-level automation system and the motor feeder and includes the following:

- Multifunctional, electronic full motor protection that is independent of the automation system
- Integrated control functions instead of hardware for the motor control
- Detailed operating, service and diagnostics data
- Open communication through PROFIBUS DP, PROFINET and OPC UA
- Safety relay function for the fail-safe disconnection of motors up to SIL 3 (IEC 61508, IEC 62061) or PL e with Category 4 (EN ISO 13849-1)
- SIMOCODE ES is the software package for SIMOCODE pro parameterization, start up and diagnostics.

Device series

SIMOCODE pro is structured into several functionally tiered series:

- SIMOCODE pro C, as a compact system for direct-on-line starters and reversing starters or for controlling a motor starter protector
- SIMOCODE pro S - the smart system for direct-on-line, reversing, and wye-delta starters or for controlling a motor starter protector or soft starter. Its expandability with a multi-function module provides comprehensive input/output project data volume, precise ground-fault detection via the 3UL23 residual-current transformers and temperature measurement.
- SIMOCODE pro V, as a variable system with all control functions and with the possibility of expanding the inputs, outputs and functions of the system at will using expansion modules

Expansion possibilities	SIMOCODE			
	pro C PROFIBUS	pro S PROFIBUS	pro V ¹⁾ PROFIBUS ²⁾	PROFINET
Operator panels	✓	✓	✓	✓
Operator panels with display	--	--	✓	✓
Current measuring modules	✓	✓	✓	✓
Current/voltage measuring modules	--	--	✓	✓
Decoupling modules	--	--	✓	✓
Expansion modules:				
• Digital modules	--	--	2	2
• Fail-safe digital modules ³⁾	--	--	1	1
• Analog modules	--	--	1	2
• Ground-fault modules	--	--	1	1
• Temperature modules	--	--	1	2
• Multifunction modules	--	1	--	--

✓ Available

-- Not available

¹⁾ Maximum of 5 expansion modules.

²⁾ When an operator panel with display and/or a decoupling module are used, more restrictions on the number of expansion modules connectable per basic unit must be observed, [see page 10/13](#).

³⁾ The fail-safe digital module can be used instead of one of the two digital modules.

Per feeder each system always comprises one basic unit and one separate current measuring module. The two modules are connected together electrically through the system interface with a connection cable and can be mounted mechanically connected as a unit (one behind the other) or separately (side by side). The motor current to be monitored is decisive only for the choice of the current measuring module.

An operator panel for mounting in the control cabinet door is optionally connectable through a second system interface on the basic unit. Both the current measuring module and the operator panel are electrically supplied by the basic unit through the connection cable. More inputs, outputs and functions can be added to the SIMOCODE pro V and SIMOCODE pro S by means of optional expansion modules, thus supplementing the inputs and outputs already existing on the basic unit. With the DM-F Local and DM-F PROFIsafe fail-safe digital modules it is also possible to integrate the fail-safe disconnection of motors in the SIMOCODE pro V motor management system.

All modules are connected by connection cables. The connection cables are available in various lengths. The maximum distance between the modules (e.g. between the basic unit and the current measuring module) must not exceed 2.5 m. The total length of all the connection cables per system interface of the basic unit may be up to 3 m.

SIMOCODE 3UF Motor Management and Control Devices

SIMOCODE pro 3UF7

General data

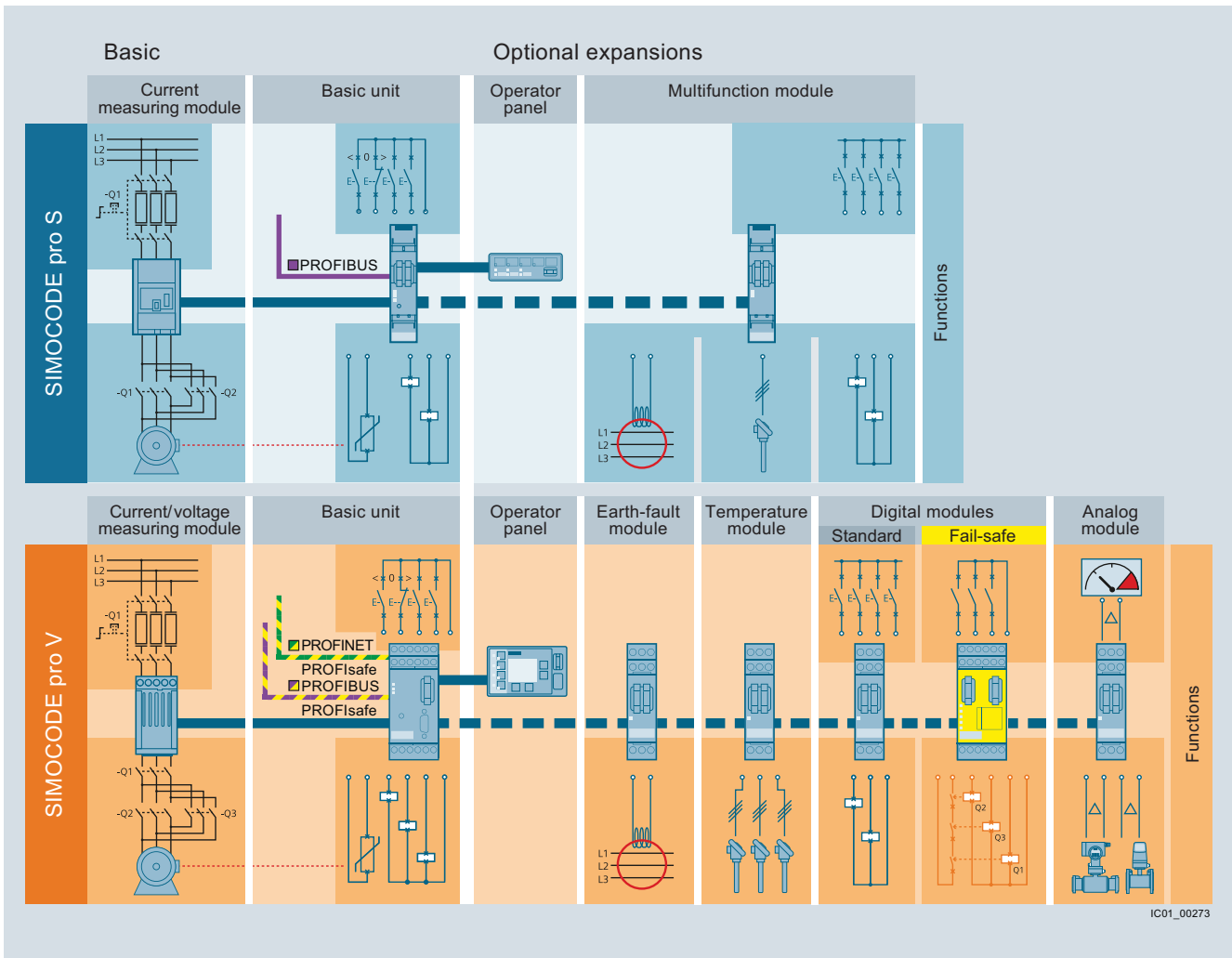

SIMOCODE pro V and SIMOCODE pro S: System structure

Article No. scheme

Digit of the Article No.	1st - 4th	5th	6th	7th	8th	9th	10th	11th	12th	13th		
	□□□□	□	□	□	-	1	□	□	0	□	-	0
SIMOCODE pro motor management system	3 U F 7											
Type of unit/module		□										
Functional version of the unit/module			□	□								
Connection type of the current transformer						□						
Voltage version							□					
Color										□		
Example	3 U F 7	0	1	0	-	1	A	B	0	0	-	0

Note:

The Article No. scheme is presented here merely for information purposes and for better understanding of the logic behind the article numbers.

For your orders, please use the article numbers quoted in the catalog in the Selection and ordering data.

Benefits

General customer benefits

- Integrating the whole motor feeder into the process control by means of PROFIBUS DP, PROFINET or OPC UA significantly reduces the wiring outlay between the motor feeder and PLC
- Decentralization of the automated processes by means of configurable control and monitoring functions in the feeder saves resources in the automation system and ensures full functionality and protection of the feeder even if the I&C or bus system fails
- The acquisition and monitoring of operating, service and diagnostics data in the feeder and process control system increases plant availability as well as maintenance and service-friendliness
- The high degree of modularity allows users to perfectly implement their plant-specific requirements for each motor feeder
- The SIMOCODE pro system offers functionally graded and space-saving solutions for each customer application
- The replacement of the control circuit hardware with integrated control functions decreases the number of hardware components and wiring required and in this way limits stock keeping costs and potential wiring errors
- The use of electronic full motor protection permits better utilization of the motors and ensures long-term stability of the tripping characteristic and reliable tripping even after years of service

Multifunctional, electronic full motor protection for rated motor currents up to 820 A

SIMOCODE pro offers comprehensive protection of the motor feeder by means of a combination of different, multi-step and delayable protection and monitoring functions:

- Inverse-time delayed electronic overload protection (CLASS 5 to 40)
- Thermistor motor protection
- Phase failure/unbalance protection
- Stall protection
- Monitoring of adjustable limit values for the motor current
- Voltage and power monitoring
- Monitoring of the power factor (motor idling/load shedding)
- Ground-fault monitoring
- Temperature monitoring, e.g. over PT100/PT1000
- Monitoring of operating hours, downtime and number of starts etc.

Recording of measuring curves

SIMOCODE pro can record measuring curves and therefore is able, for example, to present the progression of motor current during motor start up.

Flexible motor control implemented with integrated control functions (instead of comprehensive hardware interlocks)

Many predefined motor control functions have already been integrated into SIMOCODE pro, including all necessary logic operations and interlocks:

- Overload relays
- Direct-on-line and reversing starters
- Wye/delta starters (also with direction reversal)
- Two speeds, motors with separate windings (pole-changing starter); also with direction reversal
- Two speeds, motors with separate Dahlander windings (also with direction reversal)
- Positioner actuation
- Solenoid valve actuation
- Actuation of a motor starter protector
- Soft starter actuation (also with direction reversal)

These control functions are predefined in SIMOCODE pro and can be freely assigned to the inputs and outputs of the device (including PROFIBUS/PROFINET).

These predefined control functions can also be flexibly adapted to each customized configuration of a motor feeder by means of freely configurable logic modules (truth tables, counters, timers, edge evaluation, etc.) and with the help of standard functions (power failure monitoring, emergency start, external faults, etc.), without additional auxiliary relays being necessary in the control circuit.

SIMOCODE pro makes a lot of additional hardware and wiring in the control circuit unnecessary which results in a high level of standardization of the motor feeder in terms of its design and circuit diagrams.

SIMOCODE 3UF Motor Management and Control Devices

SIMOCODE pro 3UF7

General data

Detailed operational, service and diagnostics data

SIMOCODE pro makes different operating, service and diagnostics data available and helps to detect potential faults in time and to prevent them by means of preventative measures. In the event of a malfunction, a fault can be diagnosed, localized and rectified very quickly – there are no or very short downtimes.

Operating data

- Motor switching state derived from the current flow in the main circuit
- All phase currents
- All phase voltages and phase-to-phase voltages
- Active power, apparent power and power factor
- Phase unbalance and phase sequence
- Ground-fault current
- Time to trip
- Motor temperature
- Remaining cooling time etc.

Service data

- Motor operating hours
- Motor stop times
- Number of motor starts
- Number of overload trips
- Interval for compulsory testing of the enabling circuits
- Energy consumed
- Internal comments stored in the device etc.

Diagnostics data

- Numerous detailed early warning and fault messages
- Internal device fault logging with time stamp
- Time stamping of freely selectable status, alarm or fault messages etc.

Easy operation and diagnostics

Operator panel

The operator panel is used to control the motor feeder and can replace all conventional pushbuttons and indicator lights to save space. It makes SIMOCODE pro or the feeder directly operable in the control cabinet. It features all the status LEDs available on the basic unit and externalizes the system interface for simple parameterization or diagnosis on a PC/PG.

Operator panel with display

As an alternative to the 3UF720 standard operator panel for SIMOCODE pro V, there is also an operator panel with display: the 3UF721 is thus able in addition to indicate current measured values, operational and diagnostics data or status information of the motor feeder at the control cabinet. The pushbuttons of the operator panel can be used to control the motor. Also, when SIMOCODE pro V PROFINET is used it is possible to set parameters such as rated motor current, limit values, etc. directly via the operator panel with display.

Communications

SIMOCODE pro has either an integrated PROFIBUS DP interface (SUB-D or terminal connection) or a PROFINET interface (2 x RJ45).

Fail-safe disconnection through PROFIBUS or PROFINET with the PROFIsafe profile is also possible in conjunction with a fail-safe controller (F-CPU) and the DM-F PROFIsafe fail-safe digital module.

SIMOCODE pro for PROFIBUS

SIMOCODE pro for PROFIBUS supports for example:

- Cyclic services (DPV0) and acyclic services (DPV1)
- Extensive diagnostics and hardware interrupts
- Time stamp with high timing precision (SIMATIC S7) for SIMOCODE pro V
- DPV1 communication after the Y-Link

SIMOCODE pro for PROFINET

SIMOCODE pro for PROFINET supports for example:

- Line and ring bus topology thanks to an integrated switch
- Media redundancy via MRP protocol
- Operating, service and diagnostics data via standard web browser
- OPC UA server for open communication with visualization and control system
- NTP-synchronized time
- Interval function and measured values for power management via PROFIenergy
- Module exchange without PC memory module through proximity detection
- Extensive diagnostics and maintenance alarms

System redundancy with SIMOCODE pro for PROFINET

The device supports the system redundancy mechanisms of PROFINET IO and therefore can be operated directly on fault-tolerant systems such as SIMATIC S7-400 H. As such, SIMOCODE pro can provide decisive added value also for the field level of plants in which plant availability and control system redundancy are priorities.

Notes on safety

For connection of an internal system to an external system, suitable protective measures must be taken to ensure safe operation of the plant (including IT security, e.g. network segmentation).

More information, see www.siemens.com/industrialsecurity.

For SIMOCODE pro motor management and control devices with communication function, see page 10/14 onwards.

Accessories, see page 10/19 onwards.

More information, see Chapter 14 "Parameterization, Configuration and Visualization with SIRIUS" or Industry Mall.

Autonomous operation

An essential feature of SIMOCODE pro is the autonomous execution of all protection and control functions, even when communication to the I&C system is interrupted. This means that even in the event of bus system or automation system failure, full functionality of the feeder is ensured or a specific behavior can be parametrized in case of such a fault, e.g. targeted shutdown of the feeder or execution of particular parametrized control mechanisms (such as reversal of the direction of rotation).

Advantages through energy efficiency

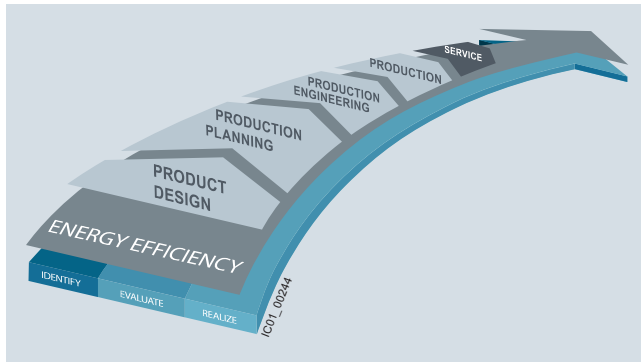

Overview of the energy management process

We offer you a unique portfolio for industrial energy management, using an energy management system that helps to optimally define your energy needs. We split up our industrial energy management into three phases – identify, evaluate, and realize – and we support you with the appropriate hardware and software solutions in every process phase.

The innovative SIRIUS industrial controls products can also make a major contribution to the energy efficiency of a plant (www.siemens.com/sirius/energysaving).

The SIMOCODE pro 3UF7 motor management system makes the following contribution to the energy efficiency of the plant as a whole:

- **Energy consumption:**
Clear display of the energy consumption of a motor feeder or process element by means of the acquisition and transmission of all operating and consumption data, such as current, voltage, active and reactive power, energy consumption, motor temperature etc.
- **Energy management:**
Evaluation of energy measured values (e.g. limit value monitoring) with exporting of local or central actions (= forwarding to higher-level)
- **PROFenergy:**
SIMOCODE pro V PROFINET supports the PROFenergy functions. Reduced energy consumption thanks to automatic disconnection in the intervals and forwarding of the measured values for higher-level energy management systems.

Application

SIMOCODE pro is often used for automated processes where plant downtimes are very expensive (e.g. steel or cement industry) and where it is important to prevent plant downtimes through detailed operating, service and diagnostics data or to localize the fault very quickly in the event of a fault.

SIMOCODE pro is modular and space-saving and suited especially for operation in motor control centers (MCCs) in the process industry and for power plant technology.

Applications

Protection and control of motors in hazardous areas for types of protection EEx e/d according to ATEX guideline 94/9/EC

- With heavy starting (paper, cement, metal and water industries)
- In high-availability plants (chemical, oil, raw material processing industries, power plants)

Safety technology for SIMOCODE pro

The safe disconnection of motors in the process industry is becoming increasingly important as the result of new and revised standards and requirements in the safety technology field.

With the DM-F Local and DM-F PROFIsafe fail-safe expansion modules it is easy to integrate functions for fail-safe disconnection into the SIMOCODE pro V motor management system while retaining service-proven concepts. The strict separation of safety functions and operational functions proves particularly advantageous for planning, configuring and construction. Seamless integration in the motor management system leads to greater transparency for diagnostics and during operation of the system.

Suitable components for this purpose are the DM-F Local and DM-F PROFIsafe fail-safe expansion modules, depending on the requirements:

- The DM-F Local fail-safe digital module for when direct assignment between a fail-safe hardware shutdown signal and a motor feeder is required, or
- The DM-F PROFIsafe fail-safe digital module for when a fail-safe controller (F-CPU) creates the signal for the disconnection and transmits it in a fail-safe manner through PROFIBUS/PROFIsafe or PROFINET/PROFIsafe to the motor management system

SIMOCODE 3UF Motor Management and Control Devices

SIMOCODE pro 3UF7

General data

Technical specifications

General data		
Type		3UF7
Permissible ambient temperature		
• During operation	°C	-25 ... +60; 3UF721: 0 ... +60
• During storage and transport	°C	-40 ... +80; 3UF721: -20 ... +70
Degree of protection (acc. to IEC 60529)		
• Measurement modules with busbar connection		IP00
• Operator panel (front) and door adapter (front) with cover		IP54
• Other components		IP20
Shock resistance (sine pulse)	g/ms	15/11
Mounting position		Any
Frequency	Hz	50/60 ± 5 %
EMC interference immunity (according to IEC 60947-1)		(corresponds to degree of severity 3)
• Conducted interference, burst acc. to IEC 61000-4-4	kV	2 (power ports)
	kV	1 (signal ports)
	V	10
• Conducted interference, high frequency acc. to IEC 61000-4-6	kV	2 (line to ground); 3UF7320-1AB, 3UF7330-1AB: 1 (line to ground)
• Conducted interference, surge acc. to IEC 61000-4-5	kV	1 (line to line); 3UF7320-1AB, 3UF7330-1AB: 0.5 (line to line)
• Electrostatic discharge, ESD acc. to IEC 61000-4-2	kV	8 (air discharge); 3UF7020: Only operate front side during operation
	kV	6 (contact discharge); 3UF721: 4 (contact discharge)
• Field-related interference acc. to IEC 61000-4-3	V/m	10
EMC emitted interference (according to IEC 60947-1)		
• Conducted and radiated interference emission		EN 55011/EN 55022 (CISPR 11/CISPR 22) (corresponds to degree of severity A)
Protective separation (acc. to IEC 60947-1)		All circuits in SIMOCODE pro are safely separated from each other according to IEC 60947-1, i.e. they are designed with doubled creepage paths and clearances. In this context, compliance with the instructions in the test report "Safe Isolation" No. 2668 is required.
Basic units		
Type		3UF7000-1AU00-0 3UF7010-1AU00-0 3UF7011-1AU00-0 3UF7020-1AU01-0
		3UF7000-1AB00-0 3UF7010-1AB00-0 3UF7011-1AB00-0 3UF7020-1AB01-0
Control circuit		
Rated control supply voltage U_s (according to IEC 61131-2)		110 ... 240 AC/DC; 50/60 Hz
Operating range		24 V DC
• SIMOCODE pro C (3UF7000) and SIMOCODE pro V (3UF7010)		0.85 ... 1.1 × U_s
• SIMOCODE pro V PN (3UF7011) and SIMOCODE pro S (3UF7020)		0.80 ... 1.2 × U_s
- Operation		0.85 ... 1.1 × U_s
- Start up		0.85 ... 1.1 × U_s
Power consumption		
• SIMOCODE pro C (3UF7000) and SIMOCODE pro S (3UF7020)		7 VA/5 W
• SIMOCODE pro V (3UF7010)		10 VA/7 W
incl. two connected expansion modules		
• SIMOCODE pro V PN (3UF7011)		11 VA/8 W
incl. two connected expansion modules		
Rated insulation voltage U_i	V	300 (at pollution degree 3)
Rated impulse withstand voltage U_{imp}	kV	4
Relay outputs		
• Number		3 monostable relay outputs
- SIMOCODE pro C, SIMOCODE pro V, SIMOCODE pro V PN		2 monostable relay outputs
- SIMOCODE pro S		
• Specified short-circuit protection for auxiliary contacts (relay outputs)		
- Fuse links		6 A operational class gG; 10 A quick-response (IEC 60947-5-1)
- Miniature circuit breaker		1.6 A, C characteristic (IEC 60947-5-1); 6 A, C characteristic (Ik < 500 A)
• Rated uninterrupted current	A	6
• Rated switching capacity		
- AC-15		6 A/24 V AC 6 A/120 V AC 3 A/230 V AC
- DC-13		2 A/24 V DC 0.55 A/60 V DC 0.25 A/125 V DC
Inputs (binary)		4 inputs supplied internally by the device electronics (with 24 V DC) and connected to a common potential
Thermistor motor protection (binary PTC)		
• Summation cold resistance	kΩ	≤ 1.5
• Response value	kΩ	3.4 ... 3.8
• Return value	kΩ	1.5 ... 1.65

SIMOCODE 3UF Motor Management and Control Devices

SIMOCODE pro 3UF7

General data

Current measuring modules or current/voltage measuring modules

Type		3UF71.0	3UF71.1	3UF71.2	3UF71.3	3UF71.4
Main circuit						
Current setting I_e	A	0.3 ... 3	2.4 ... 25	10 ... 100	20 ... 200	63 ... 630
Rated insulation voltage U_i	V	690; 3UF7103 and 3UF7104: 1 000 (at pollution degree 3)				
Rated operational voltage U_e	V	690				
Rated impulse withstand voltage U_{imp}	kV	6; 3UF7103 and 3UF7104: 8				
Rated frequency	Hz	50/60				
Type of current		Three-phase current				
Short circuit		Additional short-circuit protection is required in the main circuit				
Accuracy of current measurement (in the range of 1 x minimum current setting I_u to 8 x max. current setting I_o)	%	±3				
Typical voltage measuring range						
• Phase-to-phase voltage/line-to-line voltage (e.g. U_{L1L2})	V	110 ... 690				
• Phase voltage (e.g. U_{L1N})	V	65 ... 400				
Accuracy						
• Voltage measurement (phase voltage U_i in the range 230 ... 400 V)	%	±3 (typical)				
• Power factor measurement (in the rated load range p.f. = 0.4...0.8)	%	±5 (typical)				
• Apparent power measurement (in the rated load range)	%	±5 (typical)				
Notes on voltage measurement						
• In insulated, high-resistance or asymmetrically grounded forms of power supply system and for single-phase systems		In these networks the current/voltage measuring module can be used only with an upstream decoupling module on the system interface.				
• Supply lines for voltage measurement		In the supply lines from the main circuit for voltage measurement of SIMOCODE pro it may be necessary to provide additional line protection!				

Digital modules or multifunction modules

Type		3UF7300, 3UF7310, 3UF7600		
Control circuit				
Rated insulation voltage U_i	V	300 (at pollution degree 3)		
Rated impulse withstand voltage U_{imp}	kV	4		
Relay outputs				
• Number		2 monostable or bistable relay outputs (depending on the version)		
• Specified short-circuit protection for auxiliary contacts (relay outputs)		6 A operational class gG; 10 A quick-response (IEC 60947-5-1)		
- Fuse links		1.6 A, C characteristic (IEC 60947-5-1); 6 A, C characteristic (Ik < 500 A)		
- Miniature circuit breaker		6		
• Rated uninterrupted current	A	6		
• Rated switching capacity		6 A/24 V AC 6 A/120 V AC 3 A/230 V AC		
- AC-15		2 A/24 V DC 0.55 A/60 V DC 0.25 A/125 V DC		
- DC-13				
Inputs (binary)		4 inputs, electrically isolated, supplied externally with 24 V DC or 110 ... 240 V AC/DC depending on the version, connected to a common potential		

Ground-fault modules or multifunction modules

Type		3UF7510, 3UF7600	
Control circuit			
Connectable residual-current transformers		3UL23	
Type of current for monitoring		Type A (AC and pulsating DC residual currents)	
Adjustable response value		30 mA ... 40 A	
Relative measurement error		7.5 %	

Temperature modules or multifunction modules

Type		3UF7600, 3UF7700			
Sensor circuit					
Number of temperature sensors					
• 3UF7700		3 temperature sensors			
• 3UF7600		1 temperature sensor			
Typical sensor circuits					
• PT100	mA	1 (typical)			
• PT1000/KTY83/KTY84/NTC	mA	0.2 (typical)			
Open-circuit/short-circuit detection					
• Sensor type		PT100/PT1000	KTY83-110	KTY84	NTC
- Open circuit		✓	✓	✓	--
- Short circuit		✓	✓	✓	✓
- Measuring range	°C	-50 ... +500	-50 ... +175	-40 ... +300	80 ... 160
Measuring accuracy at 20 °C ambient temperature (T20)	K	< ±2			
Deviation due to ambient temperature (in % of measuring range)	%	0.05 per K deviation from T20			
Conversion time	ms	500			
Connection type		Two- or three-wire connection			

✓ Detection possible

-- Detection not possible

SIMOCODE 3UF Motor Management and Control Devices

SIMOCODE pro 3UF7

General data

Analog modules					
Type	3UF74				
Control circuit					
Inputs					
• Channels		2 (passive)			
• Parameterizable measuring ranges	mA	0/4 ... 20			
• Shielding		Up to 30 m shield recommended, from 30 m shield required			
• Max. input current (destruction limit)	mA	40			
• Accuracy	%	±1			
• Input resistance	Ω	50			
• Conversion time	ms	150			
• Resolution	bit	12			
• Open-circuit detection		With measuring range 4 ... 20 mA			
Outputs					
• Channels		1			
• Parameterizable output range	mA	0/4 ... 20			
• Shielding		Up to 30 m shield recommended, from 30 m shield required			
• Max. voltage at output	V DC	30			
• Accuracy	%	±1			
• Max. output load	Ω	500			
• Conversion time	ms	25			
• Resolution	bit	12			
• Short-circuit proof		Yes			
Connection type	Two-wire connection				
Electrical separation of inputs/output to the device electronics	No				
Fail-safe digital modules					
Type	3UF7320-1AB00-0 3UF7320-1AU00-0 3UF7330-1AB00-0 3UF7330-1AU00-0				
Control circuit					
Rated control supply voltage U_s	V	24 DC	110 ... 240 AC/DC; 50/60 Hz	24 DC	110 ... 240 AC/DC; 50/60 Hz
Power consumption		3 W	9.5 VA/4.5 W	4 W	11 VA/5.5 W
Rated insulation voltage	V	300			
Rated impulse withstand voltage U_{imp}	kV	4			
Relay outputs					
• Number	2 relay enabling circuits, 2 relay outputs				
Version of the fuse link For short-circuit protection of the relay enabling circuit	A	4, operational class gG			
Rated uninterrupted current	A	5			
Rated switching capacity					
• AC-15		3 A/24 V AC	3 A/120 V AC	1.5 A/230 V AC	
• DC-13		4 A/24 V DC	0.55 A/60 V DC	0.22 A/125 V DC	
Inputs (binary)	5 (with internal power supply from the device electronics)				
Cable length					
• Between sensor/start signal and evaluation electronics	m	1 500			
• For further digital signals	m	300			
Safety data¹⁾					
SIL level max. according to IEC 61508	3				
Performance level PL according to EN ISO 13849-1	e				
Category according to EN ISO 13849-1	4				
Stop category according to EN 60204-1	0				
Probability of a dangerous failure (at 40 °C) for SIL 3 applications					
• Per hour (PFH _d) at a high demand rate according to IEC 62061	1/h	4.5 × 10 ⁻⁹	4.6 × 10 ⁻⁹	4.4 × 10 ⁻⁹	4.4 × 10 ⁻⁹
• On demand (PFD _{avg}) at a low demand rate according to IEC 61508		5.4 × 10 ⁻⁶	5.5 × 10 ⁻⁶	5.1 × 10 ⁻⁶	5.2 × 10 ⁻⁶
T1 value for proof-test interval or service life according to IEC 61508	a	20			

¹⁾ More safety data, see system manual "SIMOCODE pro Safety Fail-Safe Digital Modules", <http://support.automation.siemens.com/WWW/view/en/50564852>.

More information

Configuration instructions when using an operator panel with display and/or a decoupling module with SIMOCODE pro V with PROFIBUS

If you want to use an operator panel with display and/or a decoupling module in the SIMOCODE pro V system with PROFIBUS, then the following configuration instructions concerning the type and number of connectable expansion modules must be observed.

The following tables show the maximum possible configuration of the expansion modules for the various combinations.

The DM-F Local and DM-F PROFIsafe fail-safe expansion modules behave in this connection like digital modules for standard applications.

Use of an operator panel with display

Digital module 1	Digital module 2	Analog module	Temperature module	Ground-fault module
Only operator panel with display for SIMOCODE pro V (24 V DC or 110 ... 240 V AC/DC)				
Max. 4 expansion modules can be used				
Operator panel with display and current/voltage measurement with SIMOCODE pro V (110 ... 240 V AC/DC)				
Max. 3 expansion modules can be used or:				
--	--	✓	✓	--

✓ Available

-- Not available

Use of a decoupling module (voltage measurement in insulated networks)

Digital module 1	Digital module 2	Analog module	Temperature module	Ground-fault module
SIMOCODE pro V (24 V DC)				
✓ ¹⁾	✓ ¹⁾	✓	✓	✓
SIMOCODE pro V (110 ... 240 V AC/DC)				
✓	✓	--	✓	✓
✓ ¹⁾	✓ ¹⁾	✓	✓	--
✓	--	✓	✓	--
✓	--	✓	--	✓

✓ Available

-- Not available

¹⁾ No bistable relay outputs and no more than 5 of 7 relay outputs active simultaneously (> 3 s).

Use of a decoupling module (voltage measurement in insulated networks) in combination with an operator panel with display

Digital module 1	Digital module 2	Analog module	Temperature module	Ground-fault module
SIMOCODE pro V (24 V DC)				
✓	--	✓	✓	✓
✓	✓	--	✓	✓
SIMOCODE pro V (110 ... 240 V AC/DC)				
✓ ¹⁾	--	✓	✓	✓
✓	✓	--	--	--
✓ ²⁾	✓ ²⁾	✓ ³⁾	--	--
✓	--	--	✓	✓

✓ Available

-- Not available

¹⁾ No bistable relay outputs and no more than 3 of 5 relay outputs active simultaneously (> 3 s).

²⁾ No bistable relay outputs and no more than 5 of 7 relay outputs active simultaneously (> 3 s).

³⁾ Analog module output is not used.

Protective separation

All circuits in SIMOCODE pro are safely isolated from each other in accordance with IEC 60947-1. That is, they are designed with double creepages and clearances. In the event of a fault, therefore, no parasitic voltages can be formed in neighboring circuits. The instructions of Test log No. 2668 must be complied with.

Types of protection EEx e and EEx d

The overload protection and the thermistor motor protection of the SIMOCODE pro system comply with the requirements for overload protection of explosion-proof motors to the type of protection:

- EEx d "flameproof enclosure" e.g. according to IEC 60079-1
- EEx e "increased safety" e.g. according to IEC 60079-7

When using SIMOCODE pro devices with a 24 V DC control voltage, electrical separation must be ensured using a battery or a safety transformer according to IEC 61558-2-6.

EC type test certificate: BVS 06 ATEX F 001

Test log: BVS PP 05.2029 EG.

Selection data for type-tested assemblies/load feeders

For configuration tables according to type of coordination "1" or "2", see

- Manual "Configuring SIRIUS", Article No.: 3ZX1012-0RA21-0AC0, <http://support.automation.siemens.com/WW/view/en/40625241>
- Manual "Configuring SIRIUS Innovations", Article No.: 3ZX1012-0RA21-1AC0, <http://support.automation.siemens.com/WW/view/en/39714188>
- SIMOCODE pro PROFIBUS System Manual, Article No.: 3UF7970-0AA00-0, <http://support.automation.siemens.com/WW/view/en/20017780>
- SIMOCODE pro PROFINET System Manual, Article No.: 3ZX1012-0UF70-1AC1, <http://support.automation.siemens.com/WW/view/en/61896631>

System manual

The SIMOCODE pro system manual describes the motor management system and its functions in detail. It provides information on configuration, start up, servicing and maintenance. A typical example of a reversing starter application is used to teach the user quickly and practically how to use the system. In addition to help on how to identify and rectify faults in the event of a malfunction, the manual also contains special information for servicing and maintenance. For selection of equipment and for configuration, it is recommended to consult the system manual.

A detailed description of the DM-F Local and DM-F PROFIsafe fail-safe expansion modules is provided in the system manual "SIMOCODE pro Safety Fail-Safe Digital Modules", which can be downloaded from the Internet.

Internet





More information, see www.siemens.com/simocode.

SIMOCODE 3UF Motor Management and Control Devices

SIMOCODE pro 3UF7

Basic units

Selection and ordering data

Version	DT	Screw terminals	⊕	PU (UNIT, SET, M)	PS*	PG
Article No.				Price per PU		
SIMOCODE pro						
	SIMOCODE pro C	PROFIBUS DP interface, 12 Mbit/s, RS 485 4 I/3 O freely assignable, input for thermistor connection, monostable relay outputs Rated control supply voltage U_s :				
3UF7000-1A.00-0	<ul style="list-style-type: none"> • 24 V DC ▶ • 110 ... 240 V AC/DC ▶ 	<ul style="list-style-type: none"> ▶ 3UF7000-1AB00-0 ▶ 3UF7000-1AU00-0 		1	1 unit	42J
				1	1 unit	42J
	SIMOCODE pro S¹⁾	PROFIBUS DP interface, 1.5 Mbit/s, RS 485 4 I/2 O freely assignable, input for thermistor connection, monostable relay outputs, can be expanded by a multifunction module Rated control supply voltage U_s :				
3UF7020-1A.01-0	<ul style="list-style-type: none"> • 24 V DC NEW ▶ • 110 ... 240 V AC/DC NEW ▶ 	<ul style="list-style-type: none"> ▶ 3UF7020-1AB01-0 ▶ 3UF7020-1AU01-0 		1	1 unit	42J
				1	1 unit	42J
	SIMOCODE pro V	PROFIBUS DP interface, 12 Mbit/s, RS 485 4 I/3 O freely assignable, input for thermistor connection, monostable relay outputs, can be expanded by expansion modules Rated control supply voltage U_s :				
3UF7010-1A.00-0	<ul style="list-style-type: none"> • 24 V DC ▶ • 110 ... 240 V AC/DC ▶ 	<ul style="list-style-type: none"> ▶ 3UF7010-1AB00-0 ▶ 3UF7010-1AU00-0 		1	1 unit	42J
				1	1 unit	42J
	SIMOCODE pro V PROFINET²⁾	ETHERNET/PROFINET IO, OPC UA server and web server, 100 Mbit/s, 2 x connection to bus through RJ45, PROFINET system redundancy, media redundancy protocol, 4 I/3 O freely assignable, input for thermistor connection, monostable relay outputs, can be expanded by expansion modules, web server in German/English/Chinese/Russian, Rated control supply voltage U_s :				
3UF7011-1A.00-0	<ul style="list-style-type: none"> • 24 V DC NEW ▶ • 110 ... 240 V AC/DC NEW ▶ 	<ul style="list-style-type: none"> ▶ 3UF7011-1AB00-0 ▶ 3UF7011-1AU00-0 		1	1 unit	42J
				1	1 unit	42J







¹⁾ The connection cable to the current measuring module must be at least 30 cm.

²⁾ When using an operator panel with display, the product version must be E07 or higher (from 08/2012).

SIMOCODE 3UF Motor Management and Control Devices

SIMOCODE pro 3UF7

Basic units

Version	Current setting	Width	DT	Screw terminals	⊕	PU (UNIT, SET, M)	PS*	PG	
	A	mm		Article No.	Price per PU				
SIMOCODE pro (continued)									
	Current measuring modules								
	• Straight-through transformers	0.3 ... 3	45	▶	3UF7100-1AA00-0		1	1 unit	42J
		2.4 ... 25	45	▶	3UF7101-1AA00-0		1	1 unit	42J
		10 ... 100	55	▶	3UF7102-1AA00-0		1	1 unit	42J
		20 ... 200	120	▶	3UF7103-1AA00-0		1	1 unit	42J
	• Bus connection	20 ... 200	120	▶	3UF7103-1BA00-0		1	1 unit	42J
63 ... 630		145	▶	3UF7104-1BA00-0		1	1 unit	42J	
3UF7100-1AA00-0									
	Current/voltage measuring modules for SIMOCODE pro V								
	Voltage measuring up to 690 V If required in connection with a decoupling module								
	• Straight-through transformers	0.3 ... 3	45	▶	3UF7110-1AA00-0		1	1 unit	42J
		2.4 ... 25	45	▶	3UF7111-1AA00-0		1	1 unit	42J
		10 ... 100	55	▶	3UF7112-1AA00-0		1	1 unit	42J
		20 ... 200	120	▶	3UF7113-1AA00-0		1	1 unit	42J
• Bus connection	20 ... 200	120	▶	3UF7113-1BA00-0		1	1 unit	42J	
	63 ... 630	145	▶	3UF7114-1BA00-0		1	1 unit	42J	
3UF7110-1AA00-0									
	Decoupling modules								
	For connecting upstream from a current/voltage measuring module on the system interface when using voltage detection in insulated, high-resistance or asymmetrically grounded systems and in single-phase systems			A	3UF7150-1AA00-0		1	1 unit	42J
3UF7150-1AA00-0									
	Operator panels								
	Installation in control cabinet door or front plate, for plugging into all SIMOCODE pro basic units, 10 LEDs for status indication and user-assignable buttons for controlling the motor								
	• Light gray			▶	3UF7200-1AA00-0		1	1 unit	42J
• Titanium gray			▶	3UF7200-1AA01-0		1	1 unit	42J	
3UF7200-1AA00-0									
	Operator panels								
	Installation in control cabinet door or front plate, for plugging into all SIMOCODE pro basic units, 10 LEDs for status indication and user-assignable buttons for controlling the motor								
3UF7200-1AA01-0									
	Operator panel with display for SIMOCODE pro V								
	Installation in control cabinet door or front plate, for plugging into SIMOCODE pro V and SIMOCODE pro V PN, 7 LEDs for status indication and user-assignable buttons for controlling the motor, multilingual display, e.g. for indication of measured values, status information or fault messages			▶	3UF7210-1AA00-0		1	1 unit	42J
3UF7210-1AA00-0									

Notes:

System manual "SIMOCODE pro PROFIBUS", see <http://support.automation.siemens.com/WW/view/en/20017780>.

System manual "SIMOCODE pro V PROFINET", see <http://support.automation.siemens.com/WW/view/en/61896631>.

SIMOCODE pro V basic unit in a hardened version via SIPLUS extreme upon request.

SIMOCODE 3UF Motor Management and Control Devices

SIMOCODE pro 3UF7

Expansion modules

Selection and ordering data

Version	DT	Screw terminals		PU (UNIT, SET, M)	PS*	PG
		Article No.	Price per PU			

Expansion modules for SIMOCODE pro V

With SIMOCODE pro V, it is possible to expand the type and number of inputs and outputs in steps. Each expansion module has two system interfaces on the front. Through the one system interface the expansion module is connected to the system interface of the SIMOCODE pro V using a connection cable; through the second system interface, further expansion modules or the operator panel can be connected. The power supply for the expansion modules is provided by the connection cable through the basic unit.

Note:

Please order connection cable separately, [see page 10/19](#).

Digital modules

Up to two digital modules can be used to add additional binary inputs and relay outputs to the basic unit. The input circuits of the digital modules are supplied from an external power supply.

4 binary inputs and 2 relay outputs,
up to 2 digital modules can be connected

Relay outputs	Input voltage	
Monostable	24 V DC	▶ 3UF7300-1AB00-0
	110 ... 240 V AC/DC	▶ 3UF7300-1AU00-0
Bistable	24 V DC	▶ 3UF7310-1AB00-0
	110 ... 240 V AC/DC	▶ 3UF7310-1AU00-0

Analog modules

Basic unit can be optionally expanded with analog inputs and outputs (0/4 ... 20 mA) by means of the analog module. ▶ **3UF7400-1AA00-0**

2 inputs (passive) for input and 1 output for output of 0/4 ... 20 mA signals, max. 1 analog module can be connected per pro V basic unit and max. 2 analog modules per pro V PN basic unit

Ground-fault modules¹⁾

NEW

Ground-fault monitoring using 3UL23 residual-current transformers and ground-fault modules is used in cases where precise detection of the ground-fault current is required or power systems with high impedance are grounded. ▶ **3UF7510-1AA00-0**

With the ground-fault module, it is possible to determine the precise fault current as a measured value, and to define freely selectable warning and trip limits in a wide range from 30 mA ... 40 A.

1 input for connecting a 3UL23 residual-current transformer, up to 1 ground-fault module can be connected

Note:

For corresponding residual-current transformers, [see page 10/14](#).

Temperature modules

Independently of the thermistor motor protection of the basic units, up to 3 analog temperature sensors can be evaluated using a temperature module. ▶ **3UF7700-1AA00-0**

Sensor types: PT100/PT1000, KTY83/KTY84 or NTC

3 inputs for connecting up to 3 analog temperature sensors, up to 1 temperature module can be connected per pro V basic unit and max. 2 temperature modules per pro V PN basic unit



3UF7300-1AU00-0



3UF7400-1AA00-0



3UF7510-1AA00-0



3UF7700-1AA00-0

¹⁾ Possible with pro V basic unit from product version E10 or pro V PN basic unit from product version E04, operator panel with display from product version E07.

Selection and ordering data

Version	DT	Screw terminals	⊕	PU (UNIT, SET, M)	PS*	PG
		Article No.		Price per PU		

Expansion modules for SIMOCODE pro S

With SIMOCODE pro S, it is possible to expand the type and number of inputs and outputs. The expansion module has two system interfaces on the front. Through the one system interface the expansion module is connected to the system interface of the SIMOCODE pro S using a connection cable; through the second system interface, the operator panel can be connected. The power supply for the expansion module is provided by the connection cable through the basic unit.

Note:

Please order connection cable separately, [see page 10/19](#).

Multifunction modules

The multifunction module is the expansion module of the SIMOCODE pro S device series with the following functions:

- Digital module function with four digital inputs and two monostable relay outputs
- Ground-fault module function with an input for the connection of a 3UL23 residual-current transformer with freely selectable warning and trip limits in a wide zone of 30 mA ... 40 A
- Temperature module function with an input for connecting an analog temperature sensor PT100, PT1000, KTY83, KTY84, or NTC

Max. 1 multifunction module can be connected per pro S basic unit

Input voltage of the digital inputs:

- 24 V DC
- 110 ... 240 V AC/DC

NEW ▶

3UF7600-1AB01-0

1 1 unit 42J

NEW ▶

3UF7600-1AU01-0

1 1 unit 42J



3UF7600-1AU01-0

SIMOCODE 3UF Motor Management and Control Devices

SIMOCODE pro 3UF7

Fail-safe expansion modules

Selection and ordering data

Version	DT	Screw terminals 	PU (UNIT, SET, M)	PS*	PG
		Article No.	Price per PU		
Fail-safe expansion modules for SIMOCODE pro V					
<p>Thanks to the fail-safe expansion modules, SIMOCODE pro V can be expanded with the function of a safety relay for the fail-safe disconnection of motors. A maximum of 1 fail-safe digital module can be connected; it can be used instead of a digital module.</p> <p>The fail-safe expansion modules are equipped likewise with two system interfaces at the front for making the connection to other system components. Unlike other expansion modules, power is supplied to the modules through a separate terminal connection.</p> <p><u>Note:</u> Please order connection cable separately, see page 10/19.</p>					
DM-F Local fail-safe digital modules¹⁾					
<p>For fail-safe disconnection using a hardware signal</p> <p>2 relay enabling circuits, joint switching; 2 relay outputs, common potential disconnected fail-safe; inputs for sensor circuit, start signal, cascading and feedback circuit, safety function adjustable using DIP switches</p> <p>Rated control supply voltage U_s:</p> <ul style="list-style-type: none"> ▶ 24 V DC ▶ 110 ... 240 V AC/DC 		<p>▶ 3UF7320-1AB00-0</p> <p>▶ 3UF7320-1AU00-0</p>	<p>1</p> <p>1</p>	<p>1 unit</p> <p>1 unit</p>	<p>42J</p> <p>42J</p>
DM-F PROFIsafe fail-safe digital modules¹⁾					
<p>For fail-safe disconnection using PROFIBUS/PROFIsafe or PROFINET/PROFIsafe</p> <p>2 relay enabling circuits, joint switching; 2 relay outputs, common potential disconnected fail-safe; 1 input for feedback circuit; 3 binary standard inputs</p> <p>Rated control supply voltage U_s:</p> <ul style="list-style-type: none"> ▶ 24 V DC ▶ 110 ... 240 V AC/DC 		<p>▶ 3UF7330-1AB00-0</p> <p>▶ 3UF7330-1AU00-0</p>	<p>1</p> <p>1</p>	<p>1 unit</p> <p>1 unit</p>	<p>42J</p> <p>42J</p>



3UF7320-1AB00-0



3UF7330-1AB00-0

¹⁾ Only possible with SIMOCODE pro V basic unit, product version E07 and higher (from 05/2011) or SIMOCODE pro V PN basic unit.

Note:





System manual "SIMOCODE pro Safety Fail-Safe Digital Modules", [see](#) <http://support.automation.siemens.com/WW/view/en/50564852>.

SIMOCODE 3UF Motor Management and Control Devices

SIMOCODE pro 3UF7

Accessories

Selection and ordering data

Version	DT	Article No.	Price per PU	PU (UNIT, SET, M)	PS*	PG																																																																
Connection cables (essential accessory)																																																																						
 <p>Connection cables In different lengths for connecting basic unit, current measuring module, current/voltage measuring module, operator panel or expansion modules or decoupling module</p>																																																																						
<table border="1"> <thead> <tr> <th>Version</th> <th>Length</th> <th></th> <th>Article No.</th> <th>Price per PU</th> <th>PU (UNIT, SET, M)</th> <th>PS*</th> <th>PG</th> </tr> </thead> <tbody> <tr> <td>Flat</td> <td>0.025 m</td> <td>▶</td> <td>3UF7930-0AA00-0</td> <td></td> <td>1</td> <td>1 unit</td> <td>42J</td> </tr> <tr> <td>Flat</td> <td>0.1 m</td> <td>▶</td> <td>3UF7931-0AA00-0</td> <td></td> <td>1</td> <td>1 unit</td> <td>42J</td> </tr> <tr> <td>Flat</td> <td>0.3 m</td> <td>▶</td> <td>3UF7935-0AA00-0</td> <td></td> <td>1</td> <td>1 unit</td> <td>42J</td> </tr> <tr> <td>Flat</td> <td>0.5 m</td> <td>▶</td> <td>3UF7932-0AA00-0</td> <td></td> <td>1</td> <td>1 unit</td> <td>42J</td> </tr> <tr> <td>Round</td> <td>0.5 m</td> <td>▶</td> <td>3UF7932-0BA00-0</td> <td></td> <td>1</td> <td>1 unit</td> <td>42J</td> </tr> <tr> <td>Round</td> <td>1.0 m</td> <td>▶</td> <td>3UF7937-0BA00-0</td> <td></td> <td>1</td> <td>1 unit</td> <td>42J</td> </tr> <tr> <td>Round</td> <td>2.5 m</td> <td>▶</td> <td>3UF7933-0BA00-0</td> <td></td> <td>1</td> <td>1 unit</td> <td>42J</td> </tr> </tbody> </table>							Version	Length		Article No.	Price per PU	PU (UNIT, SET, M)	PS*	PG	Flat	0.025 m	▶	3UF7930-0AA00-0		1	1 unit	42J	Flat	0.1 m	▶	3UF7931-0AA00-0		1	1 unit	42J	Flat	0.3 m	▶	3UF7935-0AA00-0		1	1 unit	42J	Flat	0.5 m	▶	3UF7932-0AA00-0		1	1 unit	42J	Round	0.5 m	▶	3UF7932-0BA00-0		1	1 unit	42J	Round	1.0 m	▶	3UF7937-0BA00-0		1	1 unit	42J	Round	2.5 m	▶	3UF7933-0BA00-0		1	1 unit	42J
Version	Length		Article No.	Price per PU	PU (UNIT, SET, M)	PS*	PG																																																															
Flat	0.025 m	▶	3UF7930-0AA00-0		1	1 unit	42J																																																															
Flat	0.1 m	▶	3UF7931-0AA00-0		1	1 unit	42J																																																															
Flat	0.3 m	▶	3UF7935-0AA00-0		1	1 unit	42J																																																															
Flat	0.5 m	▶	3UF7932-0AA00-0		1	1 unit	42J																																																															
Round	0.5 m	▶	3UF7932-0BA00-0		1	1 unit	42J																																																															
Round	1.0 m	▶	3UF7937-0BA00-0		1	1 unit	42J																																																															
Round	2.5 m	▶	3UF7933-0BA00-0		1	1 unit	42J																																																															
PC cables and adapters																																																																						
 <p>USB PC cables ▶ 3UF7941-0AA00-0 For connecting to the USB interface of a PC/PG, for communication with SIMOCODE pro through the system interface</p>																																																																						
<p>USB-to-serial adapters B 3UF7946-0AA00-0 To connect an RS 232 PC cable to the USB interface of a PC, recommended for use in conjunction with SIMOCODE pro 3UF7</p>																																																																						
Memory modules																																																																						
<p>This enables transmission to a new system, e.g. when a device is replaced, without the need for additional aids or detailed knowledge of the device.</p>																																																																						
 <p>Memory module for SIMOCODE pro C, SIMOCODE pro S and SIMOCODE pro V ▶ 3UF7900-0AA00-0 For saving the complete parameterization of a SIMOCODE pro C, SIMOCODE pro S or SIMOCODE pro V system</p>																																																																						
<p>Memory module for SIMOCODE pro V PROFINET ▶ 3UF7901-0AA00-0 For saving the complete parameterization of a SIMOCODE pro V PROFINET system</p>																																																																						
Interface covers																																																																						
 <p>Interface covers For system interface</p> <ul style="list-style-type: none"> Light gray ▶ 3UF7950-0AA00-0 Titanium gray ▶ 3RA6936-0B <p>NEW A</p>																																																																						
Addressing plugs																																																																						
 <p>Addressing plugs ▶ 3UF7910-0AA00-0 For assigning the PROFIBUS address without using a PC/PG to SIMOCODE pro through the system interface</p>																																																																						

SIMOCODE 3UF Motor Management and Control Devices

SIMOCODE pro 3UF7

Accessories

Version	DT	Article No.	Price per PU	PU (UNIT, SET, M)	PS*	PG
---------	----	-------------	--------------	-------------------	-----	----

Accessories for motor control center

With the draw-out technology often used in motor control centers it is possible to integrate a SIMOCODE pro initialization module in the switchboard on a permanent basis. Feeder-related parameter and address data can then be permanently assigned to this feeder.



3UF7902-0AA00-0

Initialization module¹⁾

NEW ▶

For automatic parameterization of SIMOCODE pro S, SIMOCODE pro V and SIMOCODE pro V PROFINET, for fixed-mounted installation in switchboards

3UF7902-0AA00-0

1

1 unit

42J

Y connection cable¹⁾

For use in conjunction with the initialization module; connects the basic unit, current measuring module or current/voltage measuring module, and initialization module

System interface length	Open cable end
0.1 m	1.0 m ▶
0.5 m	1.0 m ▶
1.0 m	1.0 m ▶

3UF7931-0CA00-0

1

1 unit

42J

3UF7932-0CA00-0

1

1 unit

42J

3UF7937-0CA00-0

1

1 unit

42J

Bus connection terminals



3UF7960-0AA00-0

Bus connection terminal

NEW ▶

For shield support and strain relief of the PROFIBUS cable on a SIMOCODE pro S

3UF7960-0AA00-0

1

1 unit

42J

Door adapters



3UF7920-0AA00-0

Door adapters

For external connection of the system interface, e.g. outside a control cabinet

3UF7920-0AA00-0

1

1 unit

42J

Adapters for operator panel



3UF7922-0AA00-0

Adapters for operator panel

The adapter enables the smaller 3UF7200 operator panel from SIMOCODE pro to be used in a front panel cutout in which previously, e.g. after a change of system, a larger 3UF52 operator panel from SIMOCODE-DP had been used, degree of protection IP54

3UF7922-0AA00-0

1

1 unit

42J

Labeling strips



3UF7925-0AA02-0

Labeling strips

- ▶ For pushbuttons of the 3UF720 operator panel
- ▶ For pushbuttons of the 3UF721 operator panel with display
- ▶ For LEDs of the 3UF720 operator panel

3UF7925-0AA00-0

100

400 units

42J

3UF7925-0AA01-0

100

600 units

42J

3UF7925-0AA02-0

100

1 200 units

42J

Push-in lugs



3RV2928-0B

Push-in lugs for screw fixing

E.g. on mounting plate, 2 units required per device

- Can be used for 3UF71.0, 3UF71.1 and 3UF71.2
- Can be used for 3UF700, 3UF701, 3UF73, 3UF74, 3UF75 and 3UF77
- Can be used for 3UF7020, 3UF7600

A

3RV2928-0B

100

10 units

41E

B

3RP1903

1

10 units

41H

A

3ZY1311-0AA00

1

10 units





41L

¹⁾ Possible with pro V basic unit, product version E09 (11/2012) and higher, pro S basic unit or pro V PN basic unit.

SIMOCODE 3UF Motor Management and Control Devices

SIMOCODE pro 3UF7

Accessories



Version	DT	Article No.	Price per PU	PU (UNIT, SET, M)	PS*	PG	
Terminal covers							
 3RT1956-4EA1	Covers for cable lugs and busbar connections						
		• Length 100 mm, can be used for 3UF71.3-1BA00-0	▶ 3RT1956-4EA1		1	1 unit	41B
		• Length 120 mm, can be used for 3UF71.4-1BA00-0	▶ 3RT1966-4EA1		1	1 unit	41B
	Covers for box terminals						
		• Length 25 mm, can be used for 3UF71.3-1BA00-0	▶ 3RT1956-4EA2		1	1 unit	41B
		• Length 30 mm, can be used for 3UF71.4-1BA00-0	▶ 3RT1966-4EA2		1	1 unit	41B
 3RT1956-4EA2	Covers for screw terminals						
	Between contactor and current measuring module or current/voltage measuring module for direct mounting						
		• Can be used for 3UF71.3-1BA00-0	▶ 3RT1956-4EA3		1	1 unit	41B
	• Can be used for 3UF71.4-1BA00-0	▶ 3RT1966-4EA3		1	1 unit	41B	
Box terminal blocks							
 3RT195.-4G	Box terminal blocks						
	For round and ribbon cables						
		• Up to 70 mm ² , can be used for 3UF71.3-1BA00-0	▶ 3RT1955-4G		1	1 unit	41B
		• Up to 120 mm ² , can be used for 3UF71.3-1BA00-0	▶ 3RT1956-4G		1	1 unit	41B
	• Up to 240 mm ² , can be used for 3UF71.4-1BA00-0	▶ 3RT1966-4G		1	1 unit	41B	
Bus termination modules							
 3UF1900-1KA00	Bus termination modules						
	With separate control supply voltage for bus termination following the last unit on the bus line						
	Supply voltage:						
	• 115/230 V AC	C	3UF1900-1KA00		1	1 unit	42J
	• 24 V DC	C	3UF1900-1KB00		1	1 unit	42J

SIMOCODE 3UF Motor Management and Control Devices

SIMOCODE pro 3UF7

Accessories **NEW**
Parameterization and service software for SIMOCODE pro 3UF7

- Delivered without PC cable

Version	DT	Article No.	Price per PU	PU (UNIT, SET, M)	PS*	PG
SIMOCODE ES (TIA Portal) V12 Basic						
	Floating License for one user Engineering software, software and documentation on DVD, 6 languages (German/English/French/Italian/Spanish/Chinese), for all SIMOCODE pro with PROFIBUS, online functions through system interface					
		▶	3ZS1322-4CC10-0YA5		1 1 unit	42J
		▶	3ZS1322-4CE10-0YB5		1 1 unit	42J
3ZS1322-4CC10-0YA5						
SIMOCODE ES (TIA Portal) V12 Standard						
	Floating License for one user Engineering software, software and documentation on DVD, 6 languages (German/English/French/Italian/Spanish/Chinese), for all SIMOCODE pro with PROFIBUS, online functions through system interface parameterizing with integrated graphics editor (CFC-based)					
		▶	3ZS1322-5CC10-0YA5		1 1 unit	42J
		▶	3ZS1322-5CE10-0YB5		1 1 unit	42J
			3ZS1322-5CC10-0YE5		1 1 unit	42J
3ZS1322-5CC10-0YA5						
	A	Upgrade for SIMOCODE ES 2007				
		Floating license for one user, engineering software, software and documentation on DVD, license key on USB stick, Class A, 6 languages (German/English/French/Italian/Spanish/Chinese), combo license for parallel use of SIMOCODE ES 2007 and SIMOCODE ES V12, for all SIMOCODE pro with PROFIBUS, online functions through the system interface, parameterizing with integrated graphics editor (CFC-based)				
	A	Powerpack for SIMOCODE ES V12 Basic				
		Floating license for one user, engineering software, license key on USB stick, Class A, 6 languages (German/English/French/Italian/Spanish/Chinese), for all SIMOCODE pro with PROFIBUS, online functions through system interface, parameterizing with integrated graphics editor (CFC-based)				
		Software Update Service				
		For 1 year with automatic extension, assuming the current software version is in use, engineering software, software and documentation on DVD, online functions through system interface, parameterizing with integrated graphics editor (CFC-based)				
		▶	3ZS1322-5CC10-0YL5		1 1 unit	42J

Notes:

Please order PC cable separately, [see page 10/19](#).

More information, [see Chapter 14 "Parameterization, Configuration and Visualization with SIRIUS"](#) or [Industry Mall](#).

SIMOCODE 3UF Motor Management and Control Devices

SIMOCODE pro 3UF7

NEW Accessories

Version	DT	Article No.	Price per PU	PU (UNIT, SET, M)	PS*	PG		
SIMOCODE ES (TIA Portal) V12 Premium								
 3ZS1322-6CC10-0YA5		Floating License for one user						
		Engineering software, software and documentation on DVD, 6 languages (German/English/French/Italian/Spanish/Chinese), for all SIMOCODE pro with PROFIBUS, online functions through system interface and PROFIBUS, parameterizing with integrated graphics editor (CFC-based)						
		▶	License key on USB stick, Class A	▶	3ZS1322-6CC10-0YA5	1	1 unit	42J
		▶	License key download, Class A	▶	3ZS1322-6CE10-0YB5	1	1 unit	42J
		A	Upgrade for SIMOCODE ES 2007	A	3ZS1322-6CC10-0YE5	1	1 unit	42J
		Floating license for one user, engineering software, software and documentation on DVD, license key on USB stick, Class A, 6 languages (German/English/French/Italian/Spanish/Chinese), combo license for parallel use of SIMOCODE ES 2007 and SIMOCODE ES V12, for all SIMOCODE pro with PROFIBUS, online functions through the system interface and PROFIBUS, parameterizing with integrated graphics editor (CFC-based)						
	A	Powerpack for SIMOCODE ES V12 Standard	A	3ZS1322-6CC10-0YD5	1	1 unit	42J	
		Floating license for one user, engineering software, license key on USB stick, Class A, 6 languages (German/English/French/Italian/Spanish/Chinese), for all SIMOCODE pro with PROFIBUS, online functions through system interface and PROFIBUS, parameterizing with integrated graphics editor (CFC-based)						
	▶	Software Update Service	▶	3ZS1322-6CC10-0YL5	1	1 unit	42J	
		For 1 year with automatic extension, assuming the current software version is in use, engineering software, software and documentation on DVD, online functions through the system interface and PROFIBUS, parameterizing with integrated graphics editor (CFC-based)						

Notes:



Please order PC cable separately, [see page 10/19](#).

More information, [see Chapter 14 "Parameterization, Configuration and Visualization with SIRIUS"](#) or Industry Mall.

SIMOCODE 3UF Motor Management and Control Devices

SIMOCODE pro 3UF7

Accessories

Version	DT	Article No.	Price per PU	PU (UNIT, SET, M)	PS*	PG	
SIMOCODE ES 2007 Basic							
	Floating License for one user						
	Engineering software, software and documentation on CD, 3 languages (German/English/French), communication through system interface						
	<ul style="list-style-type: none"> • License key on USB stick, Class A ▶ • License key download, Class A ▶ 	<ul style="list-style-type: none"> ▶ 3ZS1312-4CC10-0YA5 ▶ 3ZS1312-4CE10-0YB5 	1	1 unit	42J		
3ZS1312-4CC10-0YA5							
SIMOCODE ES 2007 Standard							
	Floating License for one user						
	Engineering software, software and documentation on CD, 3 languages (German/English/French), communication through system interface, integrated graphics editor						
	<ul style="list-style-type: none"> • License key on USB stick, Class A ▶ • License key download, Class A ▶ 	<ul style="list-style-type: none"> ▶ 3ZS1312-5CC10-0YA5 ▶ 3ZS1312-5CE10-0YB5 	1	1 unit	42J		
	Upgrade for SIMOCODE ES 2004 and later	A	3ZS1312-5CC10-0YE5		1	1 unit	42J
	3ZS1312-5CC10-0YA5						
	A	Powerpack for SIMOCODE ES 2007 Basic		1	1 unit	42J	
		Floating license for one user, engineering software, license key on USB stick, Class A, 3 languages (German/English/French), communication through system interface integrated graphics editor					
	▶	Software Update Service¹⁾		1	1 unit	42J	
		For 1 year with automatic extension, assuming the current software version is in use, engineering software, software and documentation on CD, communication through system interface, integrated graphics editor					

¹⁾ The Software Update Service for the SIRIUS ES software family (e.g. SIMOCODE ES 2007) is not automatically transferred to the TIA Portal software family (e.g. SIMOCODE ES V12).

Notes:

Please order PC cable separately, [see page 10/19](#).

More information, [see Chapter 14 "Parameterization, Configuration and Visualization with SIRIUS"](#) or [Industry Mall](#).

SIMOCODE 3UF Motor Management and Control Devices

SIMOCODE pro 3UF7

Accessories

Version	DT	Article No.	Price per PU	PU (UNIT, SET, M)	PS*	PG	
SIMOCODE ES 2007 Premium							
 3ZS1312-6CC10-0YA5		Floating License for one user					
		Engineering software, software and documentation on CD, 3 languages (German/English/French), communication through PROFIBUS/PROFINET or system interface, integrated graphics editor, STEP7 Object Manager					
		• License key on USB stick, Class A	▶	3ZS1312-6CC10-0YA5	1	1 unit	42J
		• License key download, Class A	▶	3ZS1312-6CE10-0YB5	1	1 unit	42J
		Upgrade for SIMOCODE ES 2004 and later	A	3ZS1312-6CC10-0YE5	1	1 unit	42J
	Floating license for one user, engineering software, software and documentation on CD, license key on USB stick, Class A, 3 languages (German/English/French), communication through PROFIBUS/PROFINET or system interface, integrated graphics editor, STEP7 Object Manager						
	Powerpack for SIMOCODE ES 2007 Standard	A	3ZS1312-6CC10-0YD5	1	1 unit	42J	
	Floating license for one user, engineering software, license key on USB stick, Class A, 3 languages (German/English/French), communication through PROFIBUS/PROFINET or system interface, integrated graphics editor, STEP7 Object Manager						
	Software Update Service¹⁾	▶	3ZS1312-6CC10-0YL5	1	1 unit	42J	
	For 1 year with automatic extension, assuming the current software version is in use, engineering software, software and documentation on CD, communication through PROFIBUS/PROFINET or system interface, integrated graphics editor, STEP7 Object Manager						

¹⁾ The Software Update Service for the SIRIUS ES software family (e.g. SIMOCODE ES 2007) is not automatically transferred to the TIA Portal software family (e.g. SIMOCODE ES V12).

Notes:

Please order PC cable separately, [see page 10/19](#).

More information, [see Chapter 14 "Parameterization, Configuration and Visualization with SIRIUS"](#) or Industry Mall.

SIMOCODE 3UF Motor Management and Control Devices

SIMOCODE pro 3UF7

Accessories **NEW**

Version	DT	Article No.	Price per PU	PU (UNIT, SET, M)	PS*	PG
SIMOCODE pro block library for SIMATIC PCS 7 Version V8 with Advanced Process Library (APL)						
 3ZS1632-1XX02-0YA0	▶	Engineering software V8		1	1 unit	42J
		<p>For one engineering station (single license) including runtime software for execution of the AS modules in an automation system (single license), German/English</p> <p>Scope of supply: AS modules and faceplates for integrating SIMOCODE pro into the PCS 7 process control system, with Advanced Process Library, for PCS 7 version V8.0 and higher</p> <p>Type of delivery: Software and documentation on CD, one license for one engineering station, one license for one automation system</p>	3ZS1632-1XX02-0YA0			
	▶	Runtime license V8		1	1 unit	42J
		<p>For execution of the AS modules in an automation system (single license)</p> <p>Required for using the AS modules of the engineering software V8 within a plant</p> <p>Type of delivery: One license for one automation system, without software and documentation</p>	3ZS1632-2XX02-0YB0			
	A	Upgrade for PCS 7 block library SIMOCODE pro, V6.0 or V7 to version SIMOCODE pro V8		1	1 unit	42J
		<p>For one engineering station (single license) including runtime software for execution of the AS modules in an automation system (single license), German/English</p> <p>Scope of supply: AS modules and faceplates for integrating SIMOCODE pro into the PCS 7 process control system, with Advanced Process Library for PCS 7 version V8.0 and higher</p> <p>Type of delivery: Software and documentation on CD, one license for one engineering station, one license for one automation system</p>	3ZS1632-1XX02-0YE0			

Notes:

Please order PC cable separately, [see page 10/19](#).

More information, [see Chapter 14 "Parameterization, Configuration and Visualization with SIRIUS"](#) or Industry Mall.

SIMOCODE 3UF Motor Management and Control Devices

SIMOCODE pro 3UF7

Accessories

Version	DT	Article No.	Price per PU	PU (UNIT, SET, M)	PS*	PG
SIMOCODE pro block library for SIMATIC PCS 7 Version 7						
 <p>3UF7982-0AA00-0</p>		Engineering software V7				
		▶	3UF7982-0AA10-0		1	1 unit 42J
			For one engineering station (single license) including runtime software for execution of the AS modules in an automation system (single license), German/English/French			
			Scope of supply: AS modules and faceplates for integrating SIMOCODE pro into the PCS 7 process control system, for PCS7 version V7.0/V7.1 Type of delivery: Software and documentation on CD, one license for one engineering station, one license for one automation system			
		Runtime license V7				
		▶	3UF7982-0AA11-0		1	1 unit 42J
		For execution of the AS modules in an automation system (single license)				
		Required for using the AS modules of the engineering software V7 or the engineering software migration V7-V8 on an additional automation system within a plant				
		Type of delivery: One license for one automation system, without software and documentation				
		Upgrade for PCS 7 block library SIMOCODE pro, V6.0 or V6.1 to version SIMOCODE pro V7.0/V7.1				
		A	3UF7982-0AA13-0		1	1 unit 42J
		For one engineering station (single license) including runtime software for execution of the AS modules in an automation system (single license), German/English/French				
		Scope of supply: AS modules and faceplates for integrating SIMOCODE pro into the PCS 7 process control system, for PCS7 version V7.0 or V7.1 Type of delivery: Software and documentation on CD, one license for one engineering station, one license for one automation system				
		Engineering software migration V7-V8				
		▶	3UF7982-0AA20-0		1	1 unit 42J
		For upgrading (migrating) an existing engineering software V7 of the SIMOCODE pro block library for PCS 7				
		Conditions of use: Availability of the engineering software V7 (license) of the SIMOCODE pro block library for PCS 7 for the PCS 7 version V7.0 or V7.1 The engineering software migration V7-V8 can be installed directly onto a system with PCS 7 version V8; installation of the previous version is unnecessary.				
		For one engineering station (single license) including runtime software for execution of the AS modules in an automation system (single license), German/English/French				
		Scope of supply: AS modules and faceplates for integrating SIMOCODE pro into the PCS 7 process control system, for PCS 7 version V8.0 and higher Type of delivery: software and documentation on CD, license for upgrading an existing license for one engineering station and a plant's assigned runtime licenses				

Notes:

Please order PC cable separately, [see page 10/19](#).

More information, [see Chapter 14 "Parameterization, Configuration and Visualization with SIRIUS" or Industry Mall](#).

Programming and Operating Manual SIMOCODE pro Library for PCS 7, [see](#)
<http://support.automation.siemens.com/WW/view/en/49963525>.



SIMOCODE 3UF Motor Management and Control Devices

3UF18 current transformers for overload protection

Overview

The 3UF18 current transformers are protection transformers and are used for actuating overload relays. Protection transformers are designed to ensure proportional current transfer up to a multiple of the primary rated current. The 3UF18 current transformers convert the maximum current of the corresponding operating range into the standard value of 1 A secondary.

Selection and ordering data

Mounting type	Operating range	DT	Screw terminals	⊕	PU (UNIT, SET, M)	PS*	PG	
								Article No.
For stand-alone installation								
	Screw fixing and snap-on mounting onto TH 35 standard mounting rail according to IEC 60715	0.25 ... 2.5 ¹⁾	C	3UF1843-1BA00		1	1 unit	42J
		1.25 ... 12.5 ¹⁾	C	3UF1843-2AA00		1	1 unit	42J
		2.5 ... 25 ¹⁾	C	3UF1843-2BA00		1	1 unit	42J
		12.5 ... 50	C	3UF1845-2CA00		1	1 unit	42J
		16 ... 65	C	3UF1847-2DA00		1	1 unit	42J
		25 ... 100	C	3UF1848-2EA00		1	1 unit	42J
For mounting onto contactors and stand-alone installation								
	Screw fixing	32 ... 130	C	3UF1850-3AA00		1	1 unit	42J
		50 ... 200	C	3UF1852-3BA00		1	1 unit	42J
		63 ... 250	C	3UF1854-3CA00		1	1 unit	42J
		100 ... 400	C	3UF1856-3DA00		1	1 unit	42J
		125 ... 500	C	3UF1857-3EA00		1	1 unit	42J
		160 ... 630	C	3UF1868-3FA00		1	1 unit	42J
		205 ... 820	C	3UF1868-3GA00		1	1 unit	42J

¹⁾ The following setting ranges for the protection of EEx e motors are applicable:
 3UF1843-1BA00, 0.25 ... 1.25 A;
 3UF1843-2AA00, 1.25 ... 6.3 A;
 3UF1843-2BA00, 2.5 ... 12.5 A.

Accessories

For contactor type	DT	Article No.	Price per PU	PU (UNIT, SET, M)	PS*	PG				
Terminal covers										
	For transformer/contacter combinations and stand-alone installation for transformer (cover required per connection side)									
	3UF1845	D					3TX7446-0A	1	1 unit	41B
	3UF1848	D					3TX7466-0A	1	1 unit	41B
	3UF1850, 3UF1852	B					3TX7506-0A	1	1 unit	41B
	3UF1854 to 3UF1857	B					3TX7536-0A	1	2 units	41B
	3UF1868-3FA00	B					3TX7686-0A	1	1 unit	41B
	3UF1868-3GA00	B					3TX7696-0A	1	1 unit	41B
	For covering the screw terminal for direct mounting on contactor (cover required per contactor/transformer combination)									
3UF1848	D	3TX7466-0B	1	1 unit	41B					
3UF1850, 3UF1852	D	3TX7506-0B	1	1 unit	41B					
3UF1854 to 3UF1857	D	3TX7536-0B	1	1 unit	41B					
3UF1868-3FA00	C	3TX7686-0B	1	1 unit	41B					
3UF1868-3GA00	C	3TX7696-0B	1	1 unit	41B					

Overview



LOGO! logic modules

LOGO! logic modules

- The compact, user-friendly, and low-cost solution for simple control tasks
- Compact, user-friendly, can be used universally without accessories
- All in one: The display and operator panel are integrated
- 36 different functions can be linked at a press of a button or with PC software; up to 130 times in total
- Functions can be changed simply with the press of a button. No complicated rewiring

SIPLUS LOGO! logic modules

- The control system for use in the toughest ambient conditions
- With extended temperature range from -40/-25 °C to +70 °C
- Use under medial loading (corrosive gas atmosphere)
- Condensation permissible
- With the service-proven PLC technology from LOGO!
- User-friendly handling, programming, maintenance and service
- Ideal for use in vehicle manufacturing, environmental engineering, mining, chemical plants, conveyor systems, the food industry, etc.

Accessories

- With the front panel assembly kit, mounting the logic modules is easy and safe also in front panels, with degree of protection IP65 possible
- To ensure safe operation at a combustion engine battery it may be necessary to install a SIPLUS upmeter voltage reducer between the battery and SIPLUS LOGO!

Application

The LOGO! logic module is the user-friendly, low-cost solution for simple control tasks.

LOGO! is universally applicable, e.g.:

- Building installation and wiring (lighting, shutters, awnings, doors, access control, barriers, ventilation systems, etc.)
- Control cabinet installation
- Machine and device construction (pumps, small presses, compressors, hydraulic lifts, conveyors, etc.)
- Special controls for conservatories and greenhouses
- Signal preprocessing for other controllers

The LOGO! Modular logic modules can be expanded easily for each application.

Marine approvals

American Bureau of Shipping, Bureau Veritas, Det Norske Veritas, Germanischer Lloyd, Lloyds Register of Shipping, Polski Rejestr Statków etc.

More information

More information about LOGO!, see [Catalog ST 70 "Products for Totally Integrated Automation"](#) or www.siemens.com/simatic/printmaterial.

More information about SIPLUS LOGO!, see www.siemens.com/siplus-extreme.

Brochures

Information material for downloading, see www.siemens.com/simatic/printmaterial.

LOGO! Logic Modules

LOGO! Modular basic versions

Overview



LOGO! Modular basic versions

- The space-saving basic versions
- Interface for connecting expansion modules, max. 24 digital inputs, 16 digital outputs, 8 analog inputs and 2 analog outputs can be addressed
- With connection option for LOGO! TD text display (can be connected to all LOGO! 0BA6 basic versions)

LOGO! -0BA7 versions

- Ethernet interface for communication with SIMATIC controller, SIMATIC panel and PC
- Networking of up to 8 LOGO! units
- Use of standard SD card or SIMATIC memory card

Selection and ordering data

Version	DT	Screw terminals	⊕	PU (UNIT, SET, M)	PS*	PG
		Article No.	Price per PU			
LOGO! Modular basic versions (-0BA6)						
LOGO! logic modules 24C Control supply voltage 24 V DC, 8 digital inputs 24 V DC, of which 4 can be used as analog inputs (0 ... 10 V), 4 digital outputs 24 V DC, 0.3 A, with integrated time switch; 200 function blocks can be combined, modular expandability	A	6ED1052-1CC01-0BA6		1	1 unit	200
LOGO! logic modules 12/24RC Control supply voltage 12/24 V DC, 8 digital inputs 12/24 V DC, of which 4 can be used as analog inputs (0 ... 10 V), 4 relay outputs 10 A, integrated time switch, 200 function blocks can be combined, modular expandability	A	6ED1052-1MD00-0BA6		1	1 unit	200
LOGO! logic modules 24RC Control supply voltage 24 V AC/DC, 8 digital inputs 24 V AC/DC, 4 relay outputs 10 A, integrated time switch, 200 function blocks can be combined, modular expandability	A	6ED1052-1HB00-0BA6		1	1 unit	200
LOGO! logic modules 230RC Control supply voltage 115/230 V AC/DC, 8 digital inputs 115/230 V AC/DC, 4 relay outputs 10 A, integrated time switch, 200 function blocks can be combined, modular expandability	A	6ED1052-1FB00-0BA6		1	1 unit	200
LOGO! Modular basic versions (-0BA7)						
LOGO! logic modules 12/24RC E Control supply voltage 12/24 V DC, 8 digital inputs 12/24 V DC, of which 4 can be used as analog inputs (0 ... 10 V), 4 relay outputs 10 A, integrated time switch, 400 function blocks can be combined, Ethernet interface, modular expandability	A	6ED1052-1MD00-0BA7		1	1 unit	200
LOGO! logic modules 230RC E Control supply voltage 115/230 V AC/DC, 8 digital inputs 115/230 V AC/DC, 4 relay outputs 10 A, integrated time switch, 400 function blocks can be combined, Ethernet interface, modular expandability	A	6ED1052-1FB00-0BA7		1	1 unit	200

For accessories, see page 10/39.

Overview



SIPLUS LOGO! Modular basic versions

- The space-saving basic versions
- Interface for connecting expansion modules, max. 24 digital inputs, 16 digital outputs, 8 analog inputs and 2 analog outputs can be addressed
- With connection option for LOGO! TD text display (can be connected to all LOGO! 0BA6 basic versions)

SIPLUS LOGO! -2BA7 versions

- Ethernet interface for communication with SIMATIC controller, SIMATIC panel and PC
- Networking of up to 8 LOGO! units
- Use of standard SD card or SIMATIC memory card

Note:

SIPLUS extreme products are based upon Siemens Industry standard products. The content listed here was taken over from the relevant standard products. Information specific to SIPLUS extreme has been added.

Selection and ordering data

Version	DT	Screw terminals 	PU (UNIT, SET, M)	PS*	PG
		Article No.	Price per PU		
SIPLUS LOGO! Modular basic versions (-2BA6) – extended temperature range and medial loading					
SIPLUS LOGO! 24C Control supply voltage 24 V DC, 8 digital inputs 24 V DC, of which 4 can be used as analog inputs (0 ... 10 V), 4 digital outputs 24 V DC, 0.3 A, with integrated time switch; 200 function blocks can be combined, modular expandability	D	6AG1052-1CC01-2BA6		1	1 unit 470
SIPLUS LOGO! 12/24RC Control supply voltage 12/24 V DC, 8 digital inputs 12/24 V DC, of which 4 can be used as analog inputs (0 ... 10 V), 4 relay outputs 10 A, integrated time switch, 200 function blocks can be combined, modular expandability	D	6AG1052-1MD00-2BA6		1	1 unit 470
SIPLUS LOGO! 24RC Control supply voltage 24 V AC/DC, 8 digital inputs 24 V AC/DC, 4 relay outputs 10 A, integrated time switch, 200 function blocks can be combined, modular expandability	D	6AG1052-1HB00-2BA6		1	1 unit 470
SIPLUS LOGO! 230RC Control supply voltage 115/230 V AC/DC, 8 digital inputs 115/230 V AC/DC, 4 relay outputs 10 A, integrated time switch, 200 function blocks can be combined, modular expandability	D	6AG1052-1FB00-2BA6		1	1 unit 470
SIPLUS LOGO! Modular basic versions (-2BA7) – extended temperature range and medial loading					
SIPLUS LOGO! 12/24RCE Control supply voltage 12/24 V DC, 8 digital inputs 12/24 V DC, of which 4 can be used as analog inputs (0 ... 10 V) 4 relay outputs 10 A, integrated time switch, 400 function blocks can be combined, Ethernet interface, modular expandability	NEW D	6AG1052-1MD00-2BA7		1	1 unit 470
SIPLUS LOGO! 230RCE Control supply voltage 115/230 V AC/DC, 8 digital inputs 115/230 V AC/DC, 4 relay outputs 10 A, integrated time switch; 400 function blocks can be combined, Ethernet interface, modular expandability	NEW D	6AG1052-1FB00-2BA7		1	1 unit 470

For accessories, see page 10/39.

* You can order this quantity or a multiple thereof.
Illustrations are approximate

LOGO! Logic Modules

LOGO! Modular pure versions

Overview



LOGO! Modular pure versions

- The cost-optimized basic versions
- Interface for connecting expansion modules, max. 24 digital inputs, 16 digital outputs, 8 analog inputs and 2 analog outputs can be addressed
- With connection option for LOGO! TD text display (can be connected to all LOGO! 0BA6 basic versions)

Selection and ordering data

Version	DT	Screw terminals	⊕	PU (UNIT, SET, M)	PS*	PG
		Article No.	Price per PU			
LOGO! Modular pure versions						
LOGO! logic modules 24Co Control supply voltage 24 V DC, 8 digital inputs 24 V DC, of which 4 can be used as analog inputs (0 ... 10 V), 4 digital outputs 24 V DC, 0.3 A; integrated time switch, without display and keyboard, 200 function blocks can be combined, modular expandability	A	6ED1052-2CC01-0BA6		1	1 unit	200
LOGO! logic modules 12/24RCo Control supply voltage 12/24 V DC, 8 digital inputs 12/24 V DC, of which 4 can be used as analog inputs (0 ... 10 V), 4 relay outputs 10 A, integrated time switch, without display and keyboard, 200 function blocks can be combined, modular expandability	A	6ED1052-2MD00-0BA6		1	1 unit	200
LOGO! logic modules 24RCo Control supply voltage 24 V AC/DC, 8 digital inputs 24 V AC/DC, 4 relay outputs 10 A, integrated time switch, without display and keyboard, 200 function blocks can be combined, modular expandability	A	6ED1052-2HB00-0BA6		1	1 unit	200
LOGO! logic modules 230RCo Control supply voltage 115/230 V AC/DC, 8 digital inputs 115/230 V AC/DC, 4 relay outputs 10 A, integrated time switch, without display and keyboard, 200 function blocks can be combined, modular expandability	A	6ED1052-2FB00-0BA6		1	1 unit	200

For accessories, see page 10/39.

Overview



SIPLUS LOGO! Modular pure versions

- The cost-optimized basic versions
- Interface for connecting expansion modules, max. 24 digital inputs, 16 digital outputs, 8 analog inputs and 2 analog outputs can be addressed
- With connection option for LOGO! TD text display (can be connected to all LOGO! 0BA6 basic versions)

Note:

SIPLUS extreme products are based upon Siemens Industry standard products. The content listed here was taken over from the relevant standard products. Information specific to SIPLUS extreme has been added.

Selection and ordering data

Version	DT	Screw terminals 	PU (UNIT, SET, M)	PS*	PG
		Article No.	Price per PU		
SIPLUS LOGO! Modular pure versions – extended temperature range and medial loading					
SIPLUS LOGO! 24Co Control supply voltage 24 V DC, 8 digital inputs 24 V DC, of which 4 can be used as analog inputs (0 ... 10 V), 4 digital outputs 24 V DC, 0.3 A; integrated time switch, without display and keyboard, 200 function blocks can be combined, modular expandability	D	6AG1052-2CC01-2BA6	1	1 unit	470
SIPLUS LOGO! 12/24RCo Control supply voltage 12/24 V DC, 8 digital inputs 12/24 V DC, of which 4 can be used as analog inputs (0 ... 10 V), 4 relay outputs 10 A, integrated time switch, without display and keyboard, 200 function blocks can be combined, modular expandability	D	6AG1052-2MD00-2BA6	1	1 unit	470
SIPLUS LOGO! 24RCo Control supply voltage 24 V AC/DC, 8 digital inputs 24 V AC/DC, 4 relay outputs 10 A, integrated time switch, without display and keyboard, 200 function blocks can be combined, modular expandability	D	6AG1052-2HB00-2BA6	1	1 unit	470
SIPLUS LOGO! 230RCo Control supply voltage 115/230 V AC/DC, 8 digital inputs 115/230 V AC/DC, 4 relay outputs 10 A, integrated time switch, without display and keyboard, 200 function blocks can be combined, modular expandability	D	6AG1052-2FB00-2BA6	1	1 unit	470

For accessories, see page 10/39.

LOGO! Logic Modules

LOGO! Modular expansion modules

Overview



LOGO! Modular expansion modules

- Expansion modules for connection to LOGO! Modular
- With digital inputs and outputs, analog inputs or analog outputs

Selection and ordering data

Version	DT	Screw terminals	⊕	PU (UNIT, SET, M)	PS*	PG
		Article No.	Price per PU			
LOGO! Modular expansion modules						
LOGO! DM8 24 Control supply voltage 24 V DC, 4 digital inputs 24 V DC, 4 digital outputs 24 V DC, 0.3 A	A	6ED1055-1CB00-0BA0		1	1 unit	200
LOGO! DM16 24 Control supply voltage 24 V DC, 8 digital inputs 24 V DC, 8 digital outputs 24 V DC, 0.3 A	A	6ED1055-1CB10-0BA0		1	1 unit	200
LOGO! DM8 12/24R Control supply voltage 12/24 V DC, 4 digital inputs 12/24 V DC, 4 relay outputs 5 A	A	6ED1055-1MB00-0BA1		1	1 unit	200
LOGO! DM8 24R Control supply voltage 24 V AC/DC, 4 digital inputs 24 V AC/DC, 4 relay outputs 5 A	A	6ED1055-1HB00-0BA0		1	1 unit	200
LOGO! DM16 24R Control supply voltage 24 V DC, 8 digital inputs 24 V DC, 8 relay outputs 5 A	A	6ED1055-1NB10-0BA0		1	1 unit	200
LOGO! DM8 230R Control supply voltage 115/230 V AC/DC, 4 digital inputs 115/230 V AC/DC, 4 relay outputs 5 A	A	6ED1055-1FB00-0BA1		1	1 unit	200
LOGO! DM16 230R Control supply voltage 115/230 V AC/DC, 8 digital inputs 115/230 V AC/DC, 8 relay outputs 5 A	A	6ED1055-1FB10-0BA0		1	1 unit	200
LOGO! AM2 Control supply voltage 12/24 V DC, 2 analog inputs 0 ... 10 V or 0 ... 20 mA, 10 bit resolution	A	6ED1055-1MA00-0BA0		1	1 unit	200
LOGO! AM2 PT 100 Control supply voltage 12/24 V DC, 2 analog inputs PT100, temperature range -50 °C ... 200 °C	A	6ED1055-1MD00-0BA1		1	1 unit	200
LOGO! AM2 AQ Control supply voltage 24 V DC, 2 analog outputs 0 ... 10 V, 0/4 ... 20 mA	A	6ED1055-1MM00-0BA1		1	1 unit	200

For accessories, see page 10/39.

Overview



SIPLUS LOGO! Modular expansion modules

- Expansion modules for connection to LOGO! Modular
- With digital inputs and outputs, analog inputs or analog outputs

Note:

SIPLUS extreme products are based upon Siemens Industry standard products. The content listed here was taken over from the relevant standard products. Information specific to SIPLUS extreme has been added.

Selection and ordering data

Version	DT	Screw terminals	⊕	PU (UNIT, SET, M)	PS*	PG
		Article No.	Price per PU			
SIPLUS LOGO! Modular expansion modules – extended temperature range and medial loading						
SIPLUS LOGO! DM8 24 Control supply voltage 24 V DC, 4 digital inputs 24 V DC, 4 digital outputs 24 V DC, 0.3 A, temperature range -40 ... +70 °C	D	6AG1055-1CB00-2BY0		1	1 unit	470
SIPLUS LOGO! DM8 12/24 Control supply voltage 12/24 V DC, 4 digital inputs 12/24 V DC, 4 digital outputs 24 V DC, 0.3 A, temperature range -40 ... +70 °C	D	6AG1055-1PB00-2BY0		1	1 unit	470
SIPLUS LOGO! DM8 24R Control supply voltage 24 V AC/DC, 4 digital inputs 24 V AC/DC, 4 relay outputs 5 A, temperature range -40 ... +70 °C	D	6AG1055-1HB00-2BY0		1	1 unit	470
SIPLUS LOGO! DM8 12/24R Control supply voltage 12/24 V DC, 4 digital inputs 12/24 V DC, 4 relay outputs 5 A, temperature range -40 ... +70 °C	D	6AG1055-1MB00-2BY1		1	1 unit	470
SIPLUS LOGO! DM8 230R Control supply voltage 115/230 V AC/DC, 4 digital inputs 115/230 V AC/DC, 4 relay outputs 5 A, temperature range -40 ... +70 °C	D	6AG1055-1FB00-2BY1		1	1 unit	470
SIPLUS LOGO! AM2 Control supply voltage 12/24 V DC, 2 analog inputs 0 ... 10 V or 0 ... 20 mA, 10 bit resolution, temperature range -40 ... +70 °C	D	6AG1055-1MA00-2BY0		1	1 unit	470
SIPLUS LOGO! AM2 AQ Control supply voltage 24 V DC, 2 analog inputs 0 ... 10 V, 0/4 ... 20 mA, 10 bit resolution, temperature range -40 ... +70 °C	D	6AG1055-1MM00-2BY1		1	1 unit	470
SIPLUS LOGO! DM16 24R Control supply voltage 24 V DC, 8 digital outputs 24 V DC, 8 relay outputs 5 A, temperature range -25 ... +70 °C	D	6AG1055-1NB10-2BA0		1	1 unit	470

For accessories, see page 10/39.

LOGO! Logic Modules

LOGO! CM EIB/KNX communication modules

Overview



LOGO! CM EIB/KNX communication modules

- Expansion module for the LOGO! basic versions
- For communication between the LOGO! master and external *EIB* components via *EIB*

Application

The CM EIB/KNX communication module allows communication between the LOGO! master and external *EIB* units via *EIB*. This module can be used to integrate LOGO! in an *EIB* system.

Selection and ordering data

Version	DT	Screw terminals	⊕	PU (UNIT, SET, M)	PS*	PG
		Article No.	Price per PU			
LOGO! communication module CM EIB KNX						
For connection to <i>EIB</i> , control supply voltage 24 V DC		C	6BK1700-0BA00-0AA2	1	1 unit	470

For accessories, [see page 10/39](#).

Overview



LOGO! CSM unmanaged

The module is used for the connection of a LOGO! and up to three additional nodes to an Industrial Ethernet network with 10/100 Mbit/s in an electrical line, tree or star structure.

Key features of the LOGO! CSM are:

- Unmanaged 4-port switch, of which one port on the front side is for simple diagnostics access
- Two versions for the voltage ranges 12/24 V DC or 230 V AC/DC
- It is easy to connect via four RJ45 standard plug-in connections
- Space-saving, optimized for connection to LOGO!
- Economical solution for creating small, local Ethernet networks
- Stand-alone use for networking any number of Ethernet devices

Selection and ordering data

Version	DT	Screw terminals	⊕	PU (UNIT, SET, M)	PS*	PG
		Article No.	Price per PU			
LOGO! CSM compact switch module						
Unmanaged switch for connection to a LOGO! (0BA7) and up to three additional nodes in the Industrial Ethernet with 10/100 Mbit/s; 4 x RJ45 ports; LED diagnostics, LOGO! module						
LOGO! CSM 12/24 External 12 V DC or 24 V DC power supply	A	6GK7177-1MA10-0AA0		1	1 unit	5P1
LOGO! CSM 230 External 115 ... 240 V AC power supply	A	6GK7177-1FA10-0AA0		1	1 unit	5P1

For accessories, see page 10/39.

More information

Selection Tools

To assist in selecting the right Industrial Ethernet switches as well as in the configuration of modular variants, the SIMATIC NET Selection Tool and the TIA Selection Tool are available.

SIMATIC NET Selection Tool, see

- Online version:
www.siemens.com/snst
- Offline version:
www.siemens.com/snst-download

TIA Selection Tool, see
www.siemens.com/tia-selection-tool

LOGO! Logic Modules

AS-Interface connections for LOGO!

Overview

Every LOGO! can be connected to the AS-Interface system



AS-Interface connection for LOGO!

Using the AS-Interface connection for LOGO!, an intelligent slave can be integrated in the AS-Interface system. With the modular interface it becomes possible to integrate the different basic units in the system according to their functionality. Similarly, functionalities can be quickly and easily adapted to new requirements by exchanging the basic unit.

The interface module provides four inputs and four outputs on the system. These I/Os do not actually exist in hardware terms, however, but are only virtually present through the interface on the bus.

Selection and ordering data

Version	DT	Screw terminals	PU (UNIT, SET, M)	PS*	PG
Article No.		Price per PU			
AS-Interface connections for LOGO!					
Four virtual digital inputs, four virtual digital outputs	A	3RK1400-0CE10-0AA2	1	1 unit	42C

For accessories, see page 10/39.

Selection and ordering data

Version	DT	Article No.	Price per PU	PU (UNIT, SET, M)	PS*	PG
LOGO! TD text displays						
LOGO! TD text displays 4-line text display, for connection to all LOGO!-0BA6 basic and pure versions, incl. connection cable	A	6ED1055-4MH00-0BA0		1	1 unit	200
SIPLUS LOGO! TD text displays						
SIPLUS LOGO! TD text displays (extended temperature range -10 ... +60 °C and medial loading) 4-line text display, for connection to all LOGO! basic and pure versions -0BA6 and higher, incl. connection cable	D	6AG1055-4MH00-2BA0		1	1 unit	470
SIPLUS voltage reducers						
SIPLUS Upmiter voltage reducers For safe operation at combustion engine batteries	D	6AG1053-1AA00-2AA0		1	1 unit	470
LOGO! cards (only -0BA6)						
LOGO! memory cards Program module for copying, with know-how protection	A	6ED1056-1DA00-0BA0		1	1 unit	200
LOGO! battery cards Battery modules for buffering the integrated real-time clock (not LOGO! 24)	A	6ED1056-6XA00-0BA0		1	1 unit	200
LOGO! memory/battery cards Combined program and battery modules, with know-how protection and buffering of the integrated real-time clock (not LOGO! 24)	A	6ED1056-7DA00-0BA0		1	1 unit	200
LOGO! PROM Programming units for simultaneous duplication of program module contents on up to 8 program modules	D	6AG1057-1AA01-0BA6		1	1 unit	470
LOGO! cables						
LOGO! PC cables For transferring programs between LOGO! and PC	A	6ED1057-1AA00-0BA0		1	1 unit	200
LOGO! USB PC cables For transferring programs between LOGO! and the PC, incl. drivers on CD-ROM	A	6ED1057-1AA01-0BA0		1	1 unit	200
LOGO! modem cables Adapter cable for analog modem communication	A	6ED1057-1CA00-0BA0		1	1 unit	200
Front panel assembly kits						
Front panel assembly kits						
• Width: 4 MW	C	6AG1057-1AA00-0AA0		1	1 unit	470
• Width: 4 MW, with pushbuttons	D	6AG1057-1AA00-0AA3		1	1 unit	470
• Width: 8 MW	C	6AG1057-1AA00-0AA1		1	1 unit	470
• Width: 8 MW, with pushbuttons	D	6AG1057-1AA00-0AA2		1	1 unit	470
LOGO! starter kits (-0BA6)						
In TANOS box, with USB cable, LOGO!, LOGO!Soft Comfort V6						
LOGO! starter kits 12/24 V Language-neutral with LOGO! 12/24RC (-0BA6)	A	6ED1057-3BA00-0AA6		1	1 unit	2SP
LOGO! starter kits 230 V Language-neutral with LOGO! 230RC (-0BA6)	A	6ED1057-3BA02-0AA6		1	1 unit	2SP
LOGO! TD starter kits Language-neutral with LOGO! 12/24RCo (-0BA6) and LOGO! TD	A	6ED1057-3BA10-0AA6		1	1 unit	2SP
LOGO! starter kits (-0BA7)						
In TANOS box, with Ethernet cable, LOGO!, LOGO!Soft Comfort V7, WinCC Basic V11						
LOGO! starter kits 12/24 V Language-neutral with LOGO! 12/24RCE (-0BA7) + LOGO! Power 24 V, 1.3 A	A	6ED1057-3BA00-0AA7		1	1 unit	2SP
LOGO! starter kits 230 V Language-neutral with LOGO! 230RCE (-0BA7)	A	6ED1057-3BA02-0AA7		1	1 unit	2SP
SIMATIC NET cables						
IE TP Cord RJ45/RJ45 TP cable 4 x 2 with 2 RJ45 connectors						
• 0.5 m	A	6XV1870-3QE50		1	1 unit	5K1
• 1 m	A	6XV1870-3QH10		1	1 unit	5K1
• 2 m	A	6XV1870-3QH20		1	1 unit	5K1
• 6 m	A	6XV1870-3QH60		1	1 unit	5K1
• 10 m	A	6XV1870-3QN10		1	1 unit	5K1
IE FC Outlet RJ45 For connection of industrial Ethernet FC cables and TP cords; scaled pricing from 10 and 50 units	A	6GK1901-1FC00-0AA0		1	1 unit	5K1

LOGO! Logic Modules

LOGO!Contact

Overview



LOGO!Contact

Switching module for switching resistive loads and motors directly

Application

LOGO!Contact is a switching module for direct switching of resistive loads (up to 20 A) and motors (up to 4 kW). LOGO!Contact operates hum-free without noise pollution.

LOGO!Contact is universally applicable:

- Buildings/electrical installations
- Industry and commerce

Selection and ordering data

Version	DT	Screw terminals	⊕	PU (UNIT, SET, M)	PS*	PG
		Article No.	Price per PU			
LOGO!Contact		Switching module for direct switching of resistive loads up to 20 A and motors up to 4 kW				
Switching voltage:						
• 24 V		A	6ED1057-4CA00-0AA0	1	1 unit	200
• 230 V		A	6ED1057-4EA00-0AA0	1	1 unit	200

For accessories, see page 10/39.

Overview

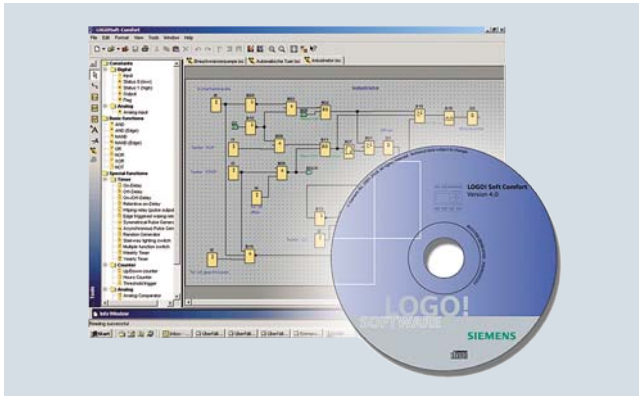

LOGO!Soft Comfort

- The user-friendly software for switching program generation on the PC
- Switching program generation for function diagrams (FBD) or contact diagrams (LAD)
- Additional testing, simulation, online testing and archiving of the switching programs
- Professional documentation with the help of various comment and print functions

The connection between LOGO! and the PC is made with the LOGO! PC cable (serial interface) or the LOGO! USB PC cable (USB interface).

With LOGO! -0BA7 the connection is made via the integrated Ethernet interface.

Minimum system requirements

Windows 98 SE, NT 4.0, ME, 2000, XP (32 bit), Vista or 7 (32/64 bit)

- Pentium PC
- 90 Mbyte free on hard disk
- 64 Mbyte RAM
- SVGA graphics card with minimum resolution of 800x600 (256 colors)

Mac OS X

- Mac OS X 10.4 with J2SE 1.5.0
- Mac OS X 10.5 with J2SE 1.6.0
- PowerMac G3, G4, G4 Cube, iMac, PowerBook G3, G4 or iBook

Linux

- Tested with SUSE Linux 10 SP2, Kernel 2.6.16
- Runs on all Linux releases on which Java 2 SDK Version 1.3.1 runs
- For hardware requirements [please consult your Linux release.](#)

Application

LOGO!Soft Comfort is the multilingual software for switching program generation with LOGO! on the PC. LOGO!Soft Comfort can be used to program all devices of the LOGO! family.

Selection and ordering data

Version	DT	Article No.	Price per PU	PU (UNIT, SET, M)	PS*	PG
LOGO!Soft Comfort						
LOGO!Soft Comfort V7.0 For programming on the PC in LAD/FBD; runs on Windows 7 (32/64 bit), VISTA, XP, NT 4.0, 2000, 98SE, Linux and Mac OSX; on CD-ROM	A	6ED1058-0BA02-0YA1		1	1 unit	200
LOGO!Soft Comfort V 7.0 Upgrade Upgrade from V1.0 to V7.0	A	6ED1058-0CA02-0YE1		1	1 unit	200

Relays

Timing Relays

General data

Overview



7PV15, SIRIUS 3RP25 and SIRIUS 3RP20 timing relays

Electronic timing relays are used in control, starting, and protective circuits for all switching operations involving time delays. Their fully developed concept and space-saving, compact design make the SIRIUS 3RP timing relays ideal modules for control cabinet, switchgear and control manufacturers in the industry.

With their narrow design, the 7PV15 timing relays are ideal in particular for use in heating, ventilation and air-conditioning systems and in compressors. All 7PV15 timing relays in this enclosure version are suitable for snap-on mounting onto TH 35 standard mounting rails according to IEC 60175. The enclosure complies with DIN 43880.

Benefits

- Clear-cut basic range with five basic units in the case of the 7PV15 timing relays, and seven basic units in the case of the 3RP timing relays
- Logistic advantages provided by versions with wide voltage range and wire setting range
- No tools required for assembly or disassembly on standard mounting rails
- Cadmium-free relay contacts
- Recyclable, halogen-free enclosure
- Optimum price/performance ratio
- Versions with logical separation
- Low variance: One design for distribution boards and for control cabinets
- Compliance with EMC requirements for buildings
- Environmentally friendly laser inscription instead of printing containing solvents
- Timing relays suitable for the 3RT miniature contactors allow smaller tier spacing
- Versions with screw terminals or alternatively with spring-type terminals

Application

Timing relays with ON-delay

- Interference pulse suppression (gating of interference pulses)
- Gradual startup of motors so as not to overload the power supply

Timing relays with OFF-delay

- Generation of overtravel functions following removal of voltage
- Gradual, delayed shutdown, e.g. of motors or fans, to allow a plant to be shut down selectively

Wye-delta timing relay

- Switchover of motors from wye to delta with a dead interval of 50 ms to prevent phase-to-phase short circuits

Multifunctional timing relays

- Maximum flexibility, with a device for every application
- Available with relay and semiconductor output

NEW SIRIUS 3RP25 timing relays, 17.5 mm and 22.5 mm

Overview

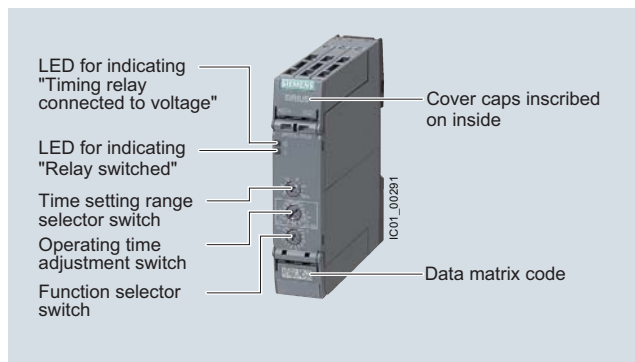

SIRIUS 3RP25 timing relays

Electronic timing relays for general use in control systems and mechanical engineering with:

- 1 or 2 CO, 1 NO (semiconductor) or 3 NO
- Monofunction or multifunction
- Combination voltage
- Wide voltage range
- Single or selectable time setting ranges
- Switch position indication and voltage indication by LED

Standards

The timing relays comply with:

- IEC 60721-3-3 "Classification of environmental conditions"
- IEC 61812-1/DIN VDE 0435 Part 2021 "Specified time relays for industrial use"
- IEC 61000-6-2, IEC 61000-6-3 and IEC 61000-6-4 "Electromagnetic compatibility"
- IEC 60947-5-1 "Low-voltage switchgear and controlgear – Electromechanical control circuit devices"

3RP2505 multifunctional timing relays

The functions of the 3RP2505 multifunctional timing relays can be set by means of the function selector switch. Whether both CO contacts are switched in parallel or one CO contact with a delay and one instantaneously and the choice of time setting range are set by means of the time setting range selector switch. The exact operating time can be adjusted with the operating time switch.

With a set of foil labels the timing relay can be legibly marked with the functions which can be selected on the timing relay. This is supplied together with the multifunctional timing relay.

The same potential must be applied to terminals A. and B.

Functions, [see the overview of functions on page 10/44](#).

Note:

The activation of loads parallel to the start input is permissible when using AC/DC control voltage ([see diagram](#)).

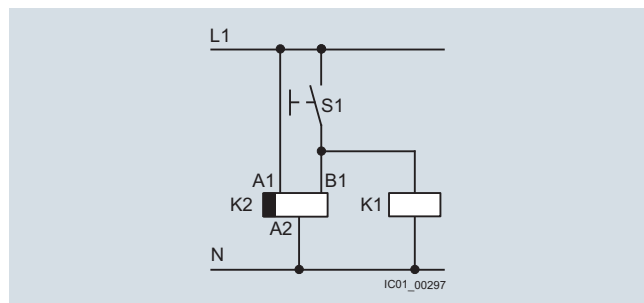

Diagram

Accessories



Push-in lugs for wall mounting

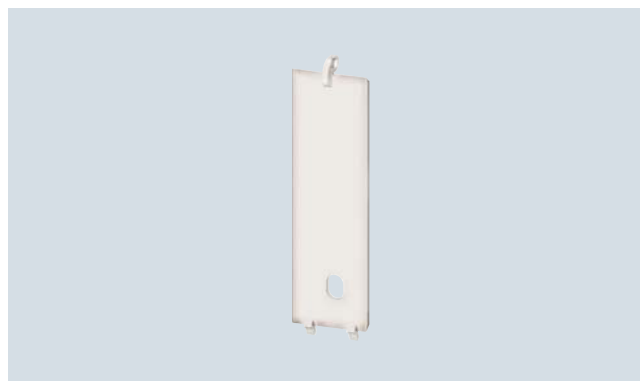

Sealable cover 17.5 mm



Sealable cover 22.5 mm

Relays

Timing Relays

SIRIUS 3RP25 timing relays, 17.5 mm and 22.5 mm **NEW**

Two setting options for implementing the multifunctions (A-M):

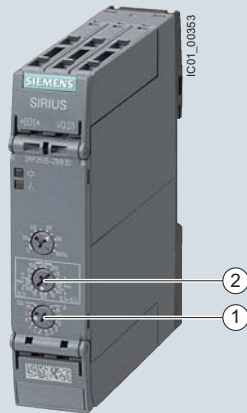

- ① Determination of 13 functions by the setting A to M, with 1 CO, 1 NO, 2 CO that switch in parallel.
- ② Extended function variance by selecting the time range and determining, whether 2 CO switch in parallel or whether 1 CO switches with delay + 1 CO switches immediately (1 CO + 1 CO)

Setting the functions on the device

Overview of functions of the 3RP2505 multifunctional timing relay

Identification letter	13 functions 1 CO, 1 NO (semiconductor) or 2 CO switched in parallel	27 functions 13 functions (A - M) 2 CO switched in parallel + 13 functions (A - M) 1 CO delayed + 1 CO instantaneous (1 CO + 1 CO) and wye-delta function
A	ON-delay	ON-delay and instantaneous contact
B	OFF-delay with control signal	OFF-delay with control signal and instantaneous contact
C	ON-delay/OFF-delay with control signal	ON-delay/OFF-delay with control signal and instantaneous contact
D	Flashing, symmetrical, starting with interval	Flashing, symmetrical, starting with interval and instantaneous contact
E	Passing make contact, interval relay	Passing make contact, interval relay and instantaneous contact
F	Retriggerable interval relay with deactivated control signal (passing break contact with control signal)	Retriggerable interval relay with deactivated control signal (passing break contact with control signal) and instantaneous contact
G	Passing make contact, with control signal, not retriggerable (pulse-forming with control signal)	Passing make contact, with control signal, not retriggerable (pulse-forming with control signal) and instantaneous contact
H	Additive ON-delay, instantaneous OFF with control signal	Additive ON-delay, instantaneous OFF with control signal and instantaneous contact
I	Additive ON-delay with control signal	Additive ON-delay with control signal and instantaneous contact
J	Flashing, symmetrical, starting with pulse	Flashing, symmetrical, starting with pulse and instantaneous contact
K	Pulse-delayed (fixed pulse (at 1 s) and settable pulse delay)	Pulse-delayed (fixed pulse (at 1 s) and settable pulse delay) and instantaneous contact
L	Pulse-delayed with control signal (fixed pulse (at 1 s) and settable pulse delay)	Pulse-delayed with control signal (fixed pulse (at 1 s) and settable pulse delay) and instantaneous contact
M	Retriggerable interval relay with activated control signal (watchdog)	Retriggerable interval relay with activated control signal and instantaneous contact (watchdog)
--	--	Wye-delta function

NEW SIRIUS 3RP25 timing relays, 17.5 mm and 22.5 mm

Conversion list

The conversion table below lists the current 3RP25 article numbers with the former 3RP15 article numbers.

Article number 3RP15	Article number 3RP25
3RP1505	
3RP1505-1AA40	3RP2505-1AW30
3RP1505-1AP30	3RP2505-1AB30 ¹⁾ , 3RP2505-1AW30
3RP1505-2AP30	3RP2505-2AB30 ¹⁾ , 3RP2505-2AW30
3RP1505-1AQ30	3RP2505-1AB30 ¹⁾ , 3RP2505-1AW30
3RP1505-2AQ30	3RP2505-2AB30 ¹⁾ , 3RP2505-2AW30
3RP1505-1AW30	3RP2505-1AW30
3RP1505-2AW30	3RP2505-2AW30
3RP1505-1BP30	3RP2505-1BB30 ¹⁾ , 3RP2505-1BW30
3RP1505-2BP30	3RP2505-2BB30 ¹⁾ , 3RP2505-2BW30
3RP1505-1BQ30	3RP2505-1BB30 ¹⁾ , 3RP2505-1BW30
3RP1505-2BQ30	3RP2505-2BB30 ¹⁾ , 3RP2505-2BW30
3RP1505-1BW30	3RP2505-1BW30
3RP1505-2BW30	3RP2505-2BW30
3RP1505-1BT20	3RP2505-1BT20
3RP1505-1RW30	On request
3RP1505-2RW30	On request
3RP1511	
3RP1511-1AP30	3RP2511-1AW30
3RP1511-2AP30	3RP2511-2AW30
3RP1511-1AQ30	3RP2511-1AW30
3RP1511-2AQ30	3RP2511-2AW30
3RP1512	
3RP1512-1AP30	3RP2512-1AW30
3RP1512-2AP30	3RP2512-2AW30
3RP1512-1AQ30	3RP2512-1AW30
3RP1512-2AQ30	3RP2512-2AW30
3RP1513	
3RP1513-1AP30	3RP2513-1AW30
3RP1513-2AP30	3RP2513-2AW30
3RP1513-1AQ30	3RP2513-1AW30
3RP1513-2AQ30	3RP2513-2AW30
3RP1525	
3RP1525-1AP30	3RP2525-1AW30
3RP1525-2AP30	3RP2525-2AW30
3RP1525-1AQ30	3RP2525-1AW30
3RP1525-2AQ30	3RP2525-2AW30
3RP1525-1BP30	3RP2525-1BB30 ¹⁾ , 3RP2525-1BW30
3RP1525-2BP30	3RP2525-2BB30 ¹⁾ , 3RP2525-2BW30
3RP1525-1BQ30	3RP2525-1BB30 ¹⁾ , 3RP2525-1BW30
3RP1525-2BQ30	3RP2525-2BB30 ¹⁾ , 3RP2525-2BW30
3RP1525-1BR30	3RP2525-1BW30
3RP1525-2BR30	3RP2525-2BW30
3RP1525-1BW30	3RP2525-1BW30
3RP1525-2BW30	3RP2525-2BW30
3RP1527	
3RP1527-1EC30	3RP2527-1EW30
3RP1527-2EC30	3RP2527-2EW30
3RP1527-1EM30	3RP2527-1EW30
3RP1527-2EM30	3RP2527-2EW30
3RP1531	
3RP1531-1AP30	3RP2535-1AW30
3RP1531-2AP30	3RP2535-2AW30
3RP1531-1AQ30	3RP2535-1AW30
3RP1531-2AQ30	3RP2535-2AW30

¹⁾ Only 24 V AC/DC.

Article number 3RP15	Article number 3RP25
3RP1532	
3RP1532-1AP30	3RP2535-1AW30
3RP1532-2AP30	3RP2535-2AW30
3RP1532-1AQ30	3RP2535-1AW30
3RP1532-2AQ30	3RP2535-2AW30
3RP1533	
3RP1533-1AP30	3RP2535-1AW30
3RP1533-2AP30	3RP2535-2AW30
3RP1533-1AQ30	3RP2535-1AW30
3RP1533-2AQ30	3RP2535-2AW30
3RP1540	
3RP1540-1AB31	3RP2540-1AB30
3RP1540-2AB31	3RP2540-2AB30
3RP1540-1AJ31	3RP2540-1AW30
3RP1540-2AJ31	3RP2540-2AW30
3RP1540-1AN31	3RP2540-1AW30
3RP1540-2AN31	3RP2540-2AW30
3RP1540-1AW31	3RP2540-1AW30
3RP1540-2AW31	3RP2540-2AW30
3RP1540-1BB31	3RP2540-1BB30
3RP1540-2BB31	3RP2540-2BB30
3RP1540-1BJ31	3RP2540-1BW30
3RP1540-2BJ31	3RP2540-2BW30
3RP1540-1BN31	3RP2540-1BW30
3RP1540-2BN31	3RP2540-2BW30
3RP1540-1BW31	3RP2540-1BW30
3RP1540-2BW31	3RP2540-2BW30
3RP1555	
3RP1555-1AR30	3RP2555-1AW30
3RP1555-2AR30	3RP2555-2AW30
3RP1555-1AP30	3RP2555-1AW30
3RP1555-2AP30	3RP2555-2AW30
3RP1555-1AQ30	3RP2555-1AW30
3RP1555-2AQ30	3RP2555-2AW30
3RP1560	
3RP1560-1SP30	3RP2560-1SW30
3RP1560-2SP30	3RP2560-2SW30
3RP1560-1SQ30	3RP2560-1SW30
3RP1560-2SQ30	3RP2560-2SW30
3RP1574	
3RP1574-1NP30	3RP2574-1NW30
3RP1574-2NP30	3RP2574-2NW30
3RP1574-1NQ30	3RP2574-1NW30
3RP1574-2NQ30	3RP2574-2NW30
3RP1574-1NM20	3RP2574-1NM20
3RP1574-2NM20	3RP2574-2NM20
3RP1576	
3RP1576-1NP30	3RP2576-1NW30
3RP1576-2NP30	3RP2576-2NW30
3RP1576-1NQ30	3RP2576-1NW30
3RP1576-2NQ30	3RP2576-2NW30
3RP1576-1NM20	3RP2576-1NM20
3RP1576-2NM20	3RP2576-2NM20

Relays

Timing Relays

SIRIUS 3RP25 timing relays, 17.5 mm and 22.5 mm **NEW**

Article No. scheme

Digit of the Article No.	1st - 5th	6th	7th	8th	9th	10th	11th	12th
	□□□□□	□	□	-	□	□	□	0
Timing relays in industrial enclosure 17.5 mm and 22.5 mm	3 R P 25							
Functions/time setting ranges		□	□					
Connection type				□				
Contacts					□			
Rated control supply voltage						□	□	
Example	3 R P 25	0	5	-	1	A	W	3 0

Note:

The Article No. scheme is presented here merely for information purposes and for better understanding of the logic behind the article numbers.

For your orders, please use the article numbers quoted in the catalog in the Selection and ordering data.

Benefits

- Easy stock keeping and logistics thanks to low variance of devices
- Reduced space requirement in the control cabinet thanks to variants in width 17.5 mm and 22 mm
- Consistent for all functions thanks to wide voltage range from 12 to 240 V AC/DC
- Up to 27 functions according to IEC 61812 in the multifunctional timing relay with wide voltage range
- Multifunctional timing relay with semiconductor output for high switching frequencies, bounce-free and wear-free switching

Application

Timing relays are used in control, starting, and protective circuits for all switching operations involving time delays. They guarantee a high level of functionality and a high repeat accuracy of timer settings.

Enclosure version

All timing relays are suitable for snap-on mounting onto TH 35 standard mounting rails according to IEC 60715 or for screw fixing.



NEW SIRIUS 3RP25 timing relays, 17.5 mm and 22.5 mm

Technical specifications

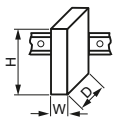
Type	3RP2505-A, 3RP2505-C, 3RP251., 3RP2525-A, 3RP2527, 3RP253., 3RP255.	3RP2505-B, 3RP2525-B, 3RP254., 3RP256., 3RP257.	
Width	mm	17.5	22.5
Height	mm	100	100
Depth	mm	90	90



Type	3RP25..											
		-AB	-AW	-BB	-BT	-BW	-CW	-EW	-NM	-NW	-SW	
Insulation voltage for overvoltage category III according to IEC 60664 for pollution degree 3, rated value	V AC	300	300	300	500	300	300	--	500	300	300	
Ambient temperature • During operation • During storage	°C	-25 ... +60										
	°C	-40 ... +80										
Operating range factor of the control supply voltage, rated value • At AC - At 50 Hz - At 60 Hz • At DC		0.85 ... 1.1	0.85 ... 1.1	0.85 ... 1.1	--	0.85 ... 1.1	0.85 ... 1.1	--	0.85 ... 1.1	0.85 ... 1.1	0.85 ... 1.1	
Switching capacity current with inductive load	A	0.01 ... 3	0.01 ... 3	0.01 ... 3	0.01 ... 3	0.01 ... 3	0.01 ... 1	0.01 ... 0.6	0.01 ... 3	0.01 ... 3	0.01 ... 3	
Operational current of the auxiliary contacts • At AC-15 - At 24 V - At 250 V - At 400 V • At DC-13 - At 24 V - At 125 V - At 250 V	A	3	3	3	3	3	1	--	3	3	3	
	A	3	3	3	3	3	1	--	3	3	3	
	A	--	--	--	3	--	--	--	3	--	--	
	A	1	1	1	1	1	1	--	1	1	1	
	A	0.2	0.2	0.2	0.2	0.2	1	--	0.2	0.2	0.2	
	A	0.1	0.1	0.1	0.1	0.1	1	--	0.1	0.1	0.1	
Uninterrupted thermal current I_{th}	A	5	5	5	5	5	1	0.6	5	5	5	
Mechanical endurance (Operating cycles) Typical		10 x 10 ⁶										
Electrical endurance for AC-15 at 230 V, typical		1 x 10 ⁵										

Type	3RP25	
Connection type	 Screw terminals	
• Design of thread of connection screw	M3	
• Solid	mm ²	1 x (0.5 ... 4)/2 x (0.5 ... 2.5)
• Finely stranded with end sleeve	mm ²	1 x (0.5 ... 4)/2 x (0.5 ... 1.5)
• Solid for AWG cables	AWG	1 x (20 ... 12), 2 x (20 ... 14)
• Stranded for AWG cables	AWG	1 x (20 ... 12), 2 x (20 ... 14)
• Tightening torque	Nm	0.6 ... 0.8
Connection type	 Spring-type terminals	
• Solid	mm ²	1 x (0.5 ... 4)
• Finely stranded with end sleeve	mm ²	1 x (0.5 ... 2.5)
• AWG cables, solid	AWG	1 x (20 ... 12)
• AWG cables, stranded	AWG	--

Relays

Timing Relays

SIRIUS 3RP25 timing relays, 17.5 mm and 22.5 mm **NEW**

Internal circuit diagrams 3RP25

Multifunction 3RP2505-.A, 13 functions, 1 CO

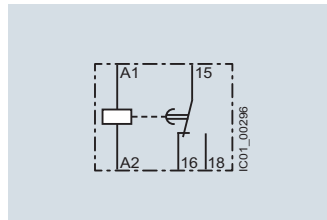

3RP2505-.A (A)
ON-delay

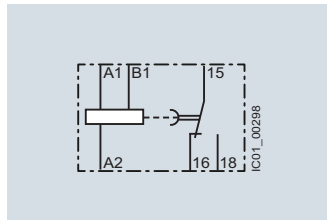

3RP2505-.A (B)
OFF-delay with control signal

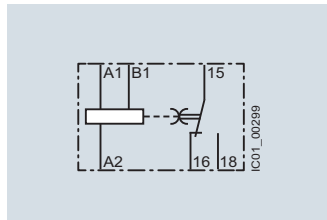

3RP2505-.A (C)
ON-delay/OFF-delay with control signal

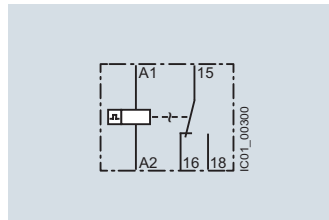

3RP2505-.A (D)
Flashing, symmetrical, starting with interval

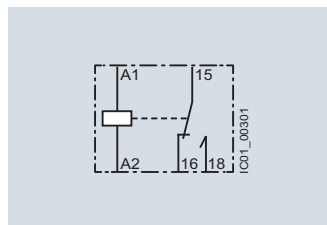

3RP2505-.A (E)
Passing make contact, interval relay

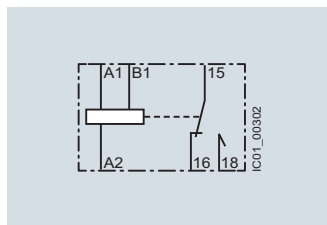

3RP2505-.A (F)
Retriggerable interval relay with deactivated control signal (passing break contact with control signal)

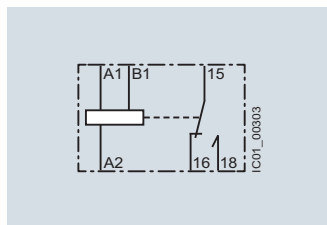

3RP2505-.A (G)
Passing make contact with control signal, not retriggerable (pulse-forming with control signal)

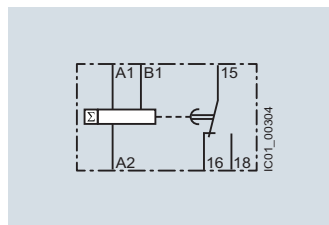

3RP2505-.A (H)
Additive ON-delay, instantaneous OFF with control signal

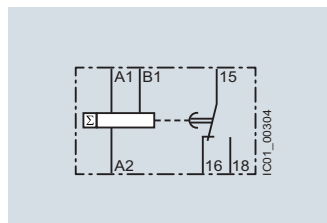

3RP2505-.A (I)
Additive ON-delay with control signal

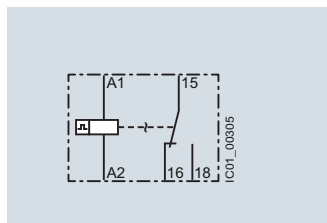

3RP2505-.A (J)
Flashing, symmetrical, starting with pulse

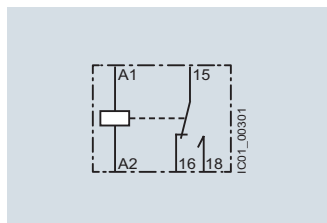

3RP2505-.A (K)
Pulse-delayed (fixed pulse (at 1 s) and settable pulse delay)

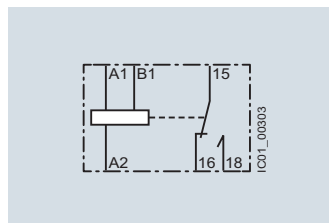

3RP2505-.A (L)
Pulse-delayed with control signal (fixed pulse (at 1 s) and settable pulse delay)

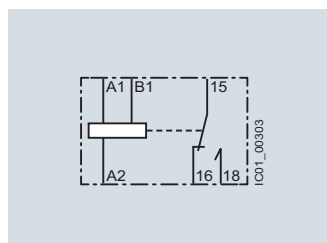

3RP2505-.A (M)
Retriggerable interval relay with activated control signal (watchdog)

10

NEW SIRIUS 3RP25 timing relays, 17.5 mm and 22.5 mm

Multifunction 3RP2505-.C, 13 functions, 1 NO (semiconductor)

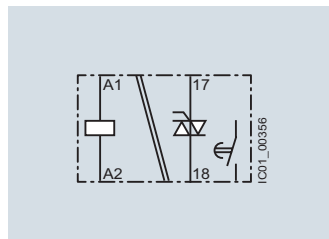

3RP2505-.C (A)
ON-delay

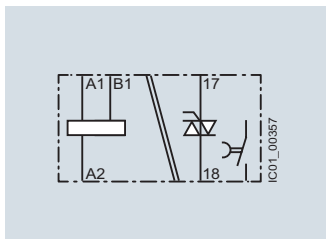

3RP2505-.C (B)
OFF-delay with control signal

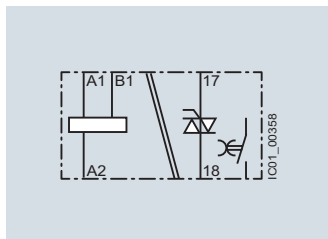

3RP2505-.C (C)
ON-delay/OFF-delay with control signal

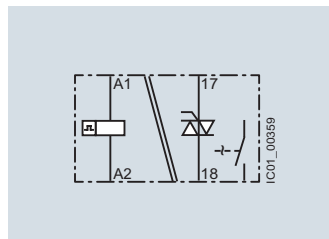

3RP2505-.C (D)
Flashing, symmetrical, starting with interval

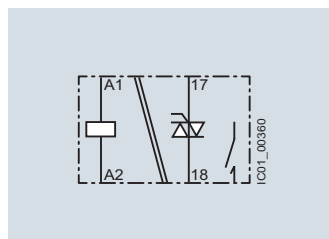

3RP2505-.C (E)
Passing make contact, interval relay

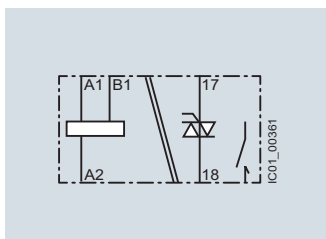

3RP2505-.C (F)
Retriggerable interval relay with deactivated control signal (passing break contact with control signal)

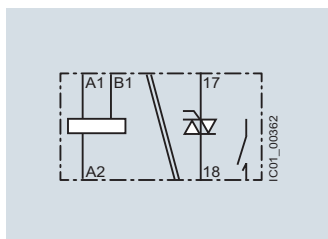

3RP2505-.C (G)
Passing make contact with control signal, not retriggerable (pulse-forming with control signal)

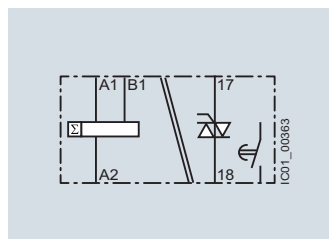

3RP2505-.C (H)
Additive ON-delay, instantaneous OFF with control signal

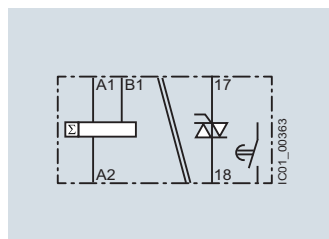

3RP2505-.C (I)
Additive ON-delay with control signal

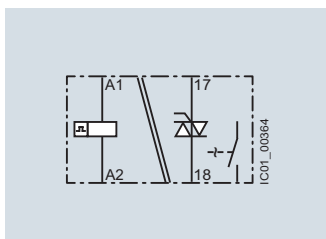

3RP2505-.C (J)
Flashing, symmetrical, starting with pulse

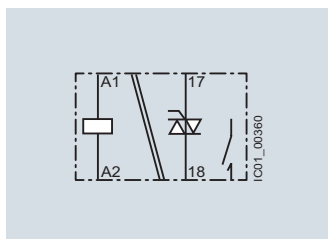

3RP2505-.C (K)
Pulse-delayed (fixed pulse (at 1 s) and settable pulse delay)

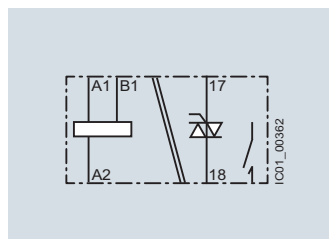

3RP2505-.C (L)
Pulse-delayed with control signal (fixed pulse (at 1 s) and settable pulse delay)

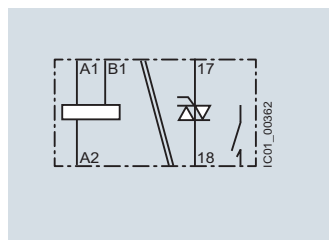

3RP2505-.C (M)
Retriggerable interval relay with activated control signal (watchdog)

Relays

Timing Relays

SIRIUS 3RP25 timing relays, 17.5 mm and 22.5 mm **NEW**

Multifunction 3RP2505-.B, 27 functions, 2 CO switched in parallel with delay

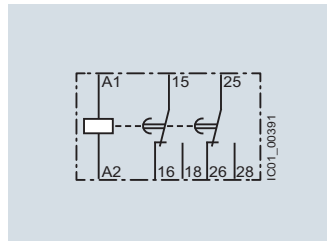

3RP2505-.B (A)
ON-delay

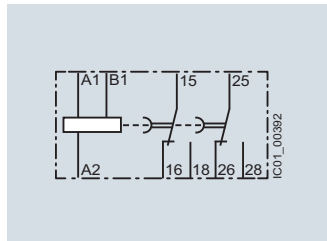

3RP2505-.B (B)
OFF-delay with control signal

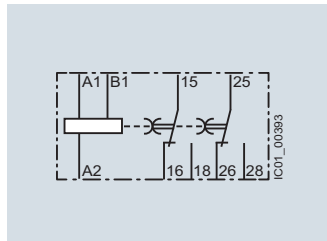

3RP2505-.B (C)
ON-delay/OFF-delay with control signal

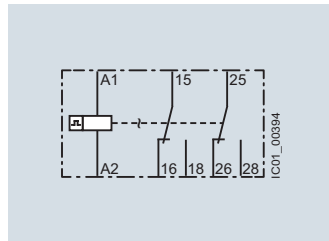

3RP2505-.B (D)
Flashing, symmetrical, starting with interval

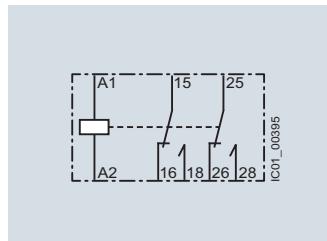

3RP2505-.B (E)
Passing make contact, interval relay

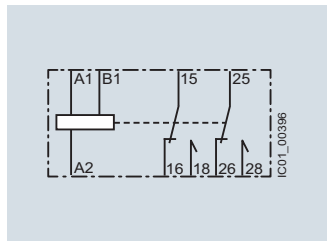

3RP2505-.B (F)
Retriggerable interval relay with deactivated control signal (passing break contact with control signal)

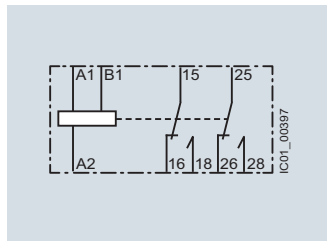

3RP2505-.B (G)
Passing make contact with control signal, not retriggerable (pulse-forming with control signal)

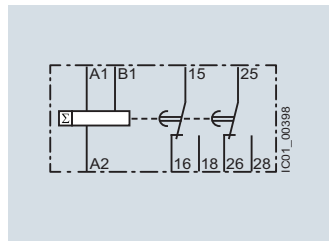

3RP2505-.B (H)
Additive ON-delay, instantaneous OFF with control signal

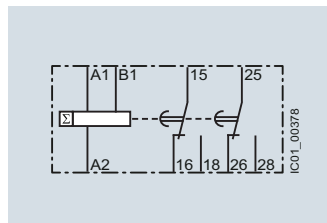

3RP2505-.B (I)
Additive ON-delay with control signal

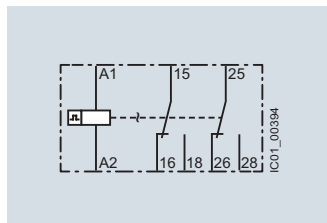

3RP2505-.B (J)
Flashing, symmetrical, starting with pulse

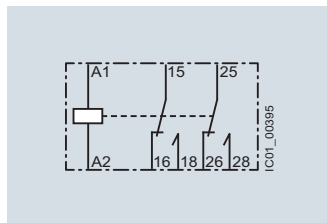

3RP2505-.B (K)
Pulse-delayed (fixed pulse (at 1 s) and settable pulse delay)

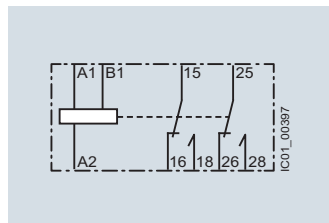

3RP2505-.B (L)
Pulse-delayed with control signal (fixed pulse (at 1 s) and settable pulse delay)

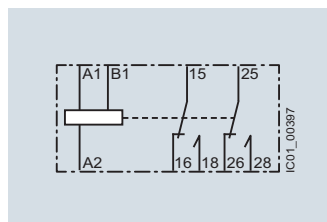

3RP2505-.B (M)
Retriggerable interval relay with activated control signal (watchdog)

10

NEW SIRIUS 3RP25 timing relays, 17.5 mm and 22.5 mm

Multifunction 3RP2505-.B, 27 functions, 1 CO delayed + 1 CO instantaneous

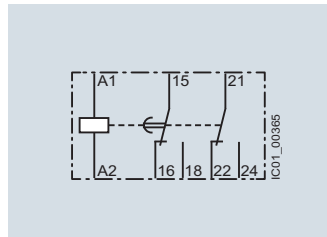

3RP2505-.B (A)
ON-delay and instantaneous contact

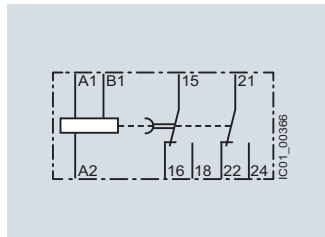

3RP2505-.B (B)
OFF-delay with control signal and instantaneous contact

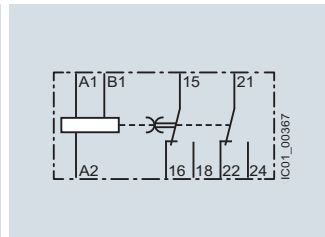

3RP2505-.B (C)
ON-delay/OFF-delay with control signal and instantaneous contact

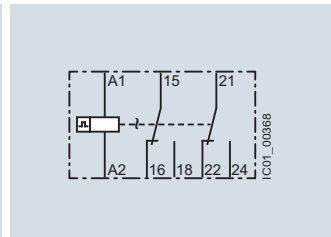

3RP2505-.B (D)
Flashing, symmetrical, starting with interval and instantaneous contact

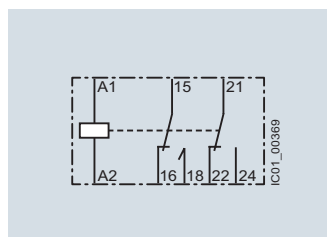

3RP2505-.B (E)
Passing make contact, interval relay and instantaneous contact

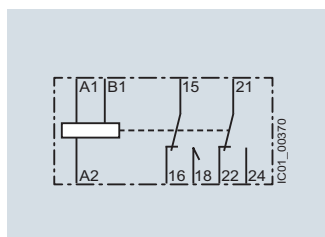

3RP2505-.B (F)
Retriggerable interval relay with deactivated control signal (passing break contact with control signal) and instantaneous contact

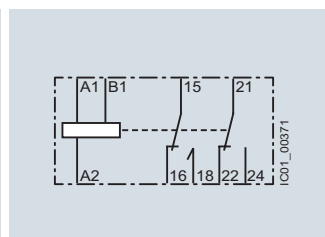

3RP2505-.B (G)
Passing make contact with control signal (not retriggerable (pulse-forming with control signal) and instantaneous contact

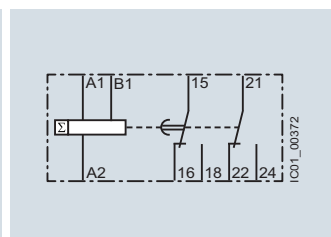

3RP2505-.B (H)
Additive ON-delay, instantaneous OFF with control signal and instantaneous contact

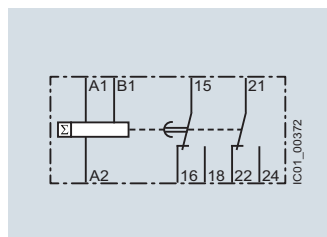

3RP2505-.B (I)
Additive ON-delay with control signal and instantaneous contact

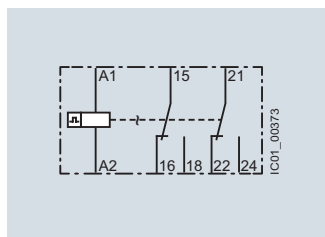

3RP2505-.B (J)
Flashing, symmetrical, starting with pulse and instantaneous contact

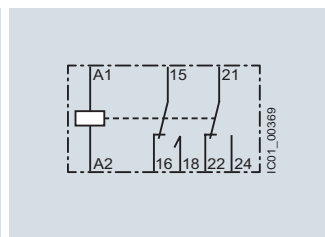

3RP2505-.B (K)
Pulse-delayed (fixed pulse (at 1 s) and settable pulse delay) and instantaneous contact

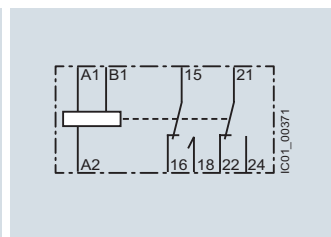

3RP2505-.B (L)
Pulse-delayed with control signal (fixed pulse (at 1 s) and settable pulse delay) and instantaneous contact

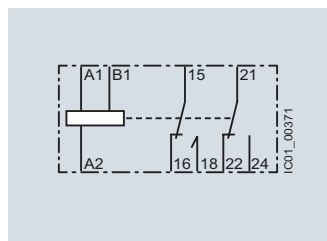

3RP2505-.B (M)
Retriggerable interval relay with activated control signal and instantaneous contact (watchdog)

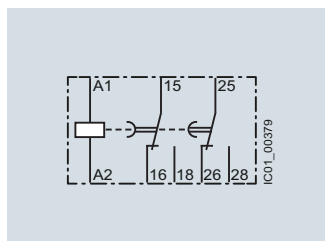

3RP2505-.B
Wye-delta function

Relays

Timing Relays

SIRIUS 3RP25 timing relays, 17.5 mm and 22.5 mm **NEW**

Monofunctions 3RP251.. up to 3RP257.¹⁾

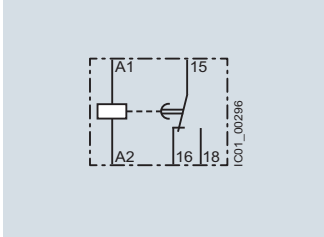

3RP251., 3RP2525-A
ON-delay

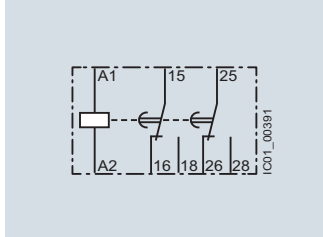

3RP2525-B
ON-delay

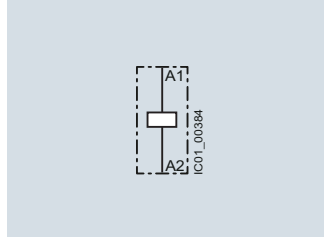

3RP2527
ON-delay, two-wire design

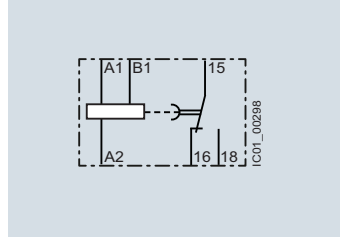

3RP2535
OFF-delay with control signal

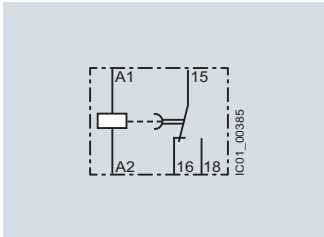

3RP2540-A (N)¹⁾
OFF-delay

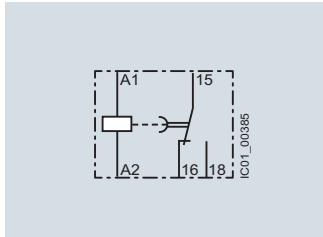

3RP2540-A (O)¹⁾
Positive passing make contact

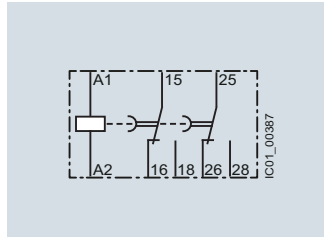

3RP2540-B (N)¹⁾
OFF-delay

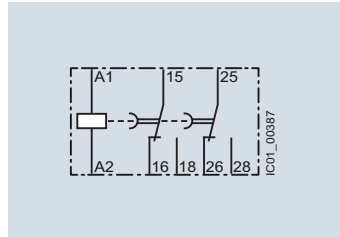

3RP2540-B (O)¹⁾
Positive passing make contact

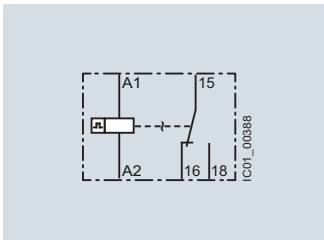

3RP2555
Flashing, asymmetrical, starting with interval (clock-pulse relay)

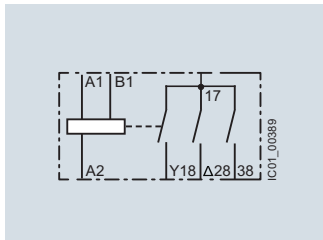

3RP2560
Wye-delta function with overtravel function (idling)

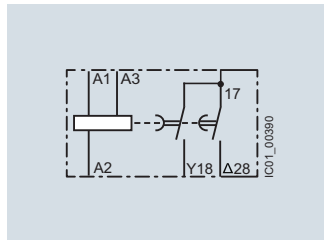

3RP257.
Wye-delta function

¹⁾ 3RP2540 has a double function:
Function N = OFF-delay
Function O = positive passing make contact.

NEW SIRIUS 3RP25 timing relays, 17.5 mm and 22.5 mm

3RP25 function diagrams

Multifunction 3RP2505-.A, 1 CO, 13 functions and 3RP2505-.C, 1 NO (semiconductor), 13 functions

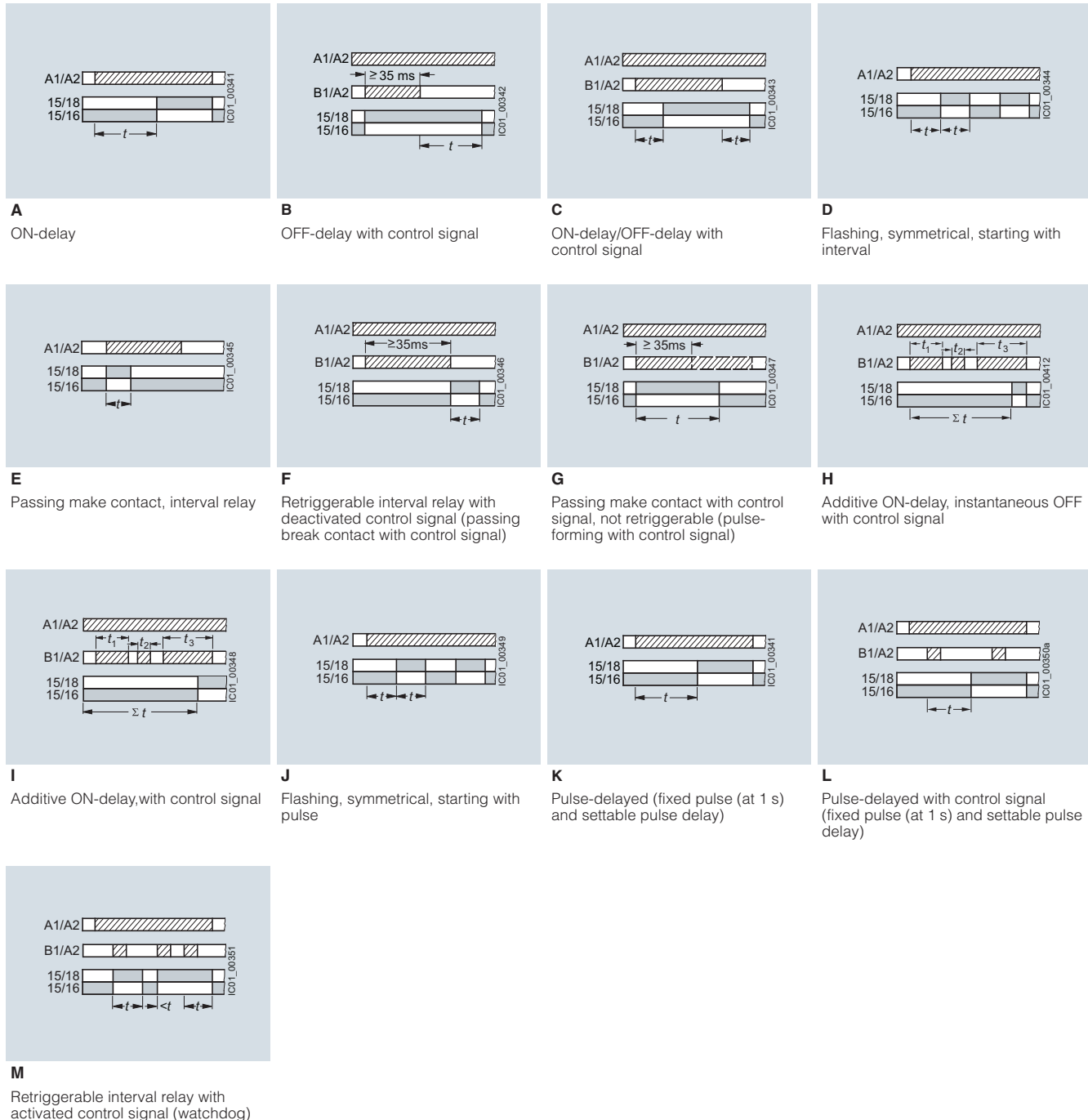

Legend

- A ... M** identification letters
- Timing relay energized
- Contact closed
- Contact open

Relays

Timing Relays

SIRIUS 3RP25 timing relays, 17.5 mm and 22.5 mm **NEW**

Multifunction 3RP2505-.B, 27 functions, 2 CO

A

2 CO switched in parallel

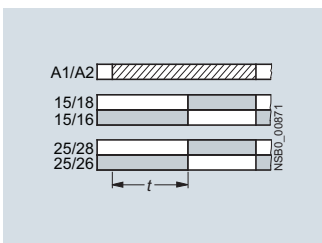

ON-delay

1 CO delayed +
1 CO instantaneous

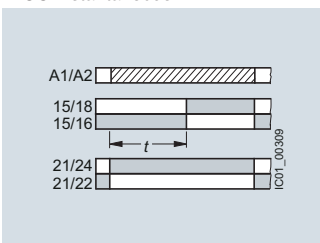

ON-delay and instantaneous contact

B

2 CO switched in parallel

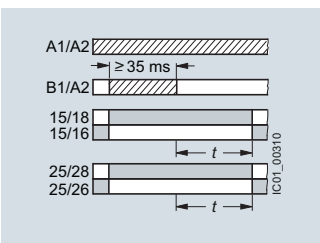

OFF-delay with control signal

1 CO delayed +
1 CO instantaneous

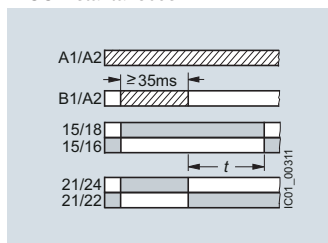

OFF-delay with control signal and instantaneous contact

C

2 CO switched in parallel

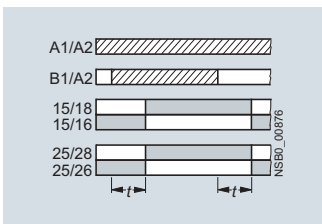

ON-delay/OFF-delay with control signal

1 CO delayed +
1 CO instantaneous

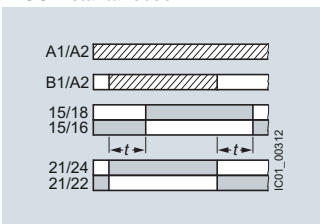

ON-delay/OFF-delay with control signal and instantaneous contact

D

2 CO switched in parallel

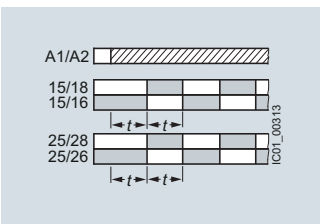

Flashing, symmetrical, starting with interval

1 CO delayed +
1 CO instantaneous

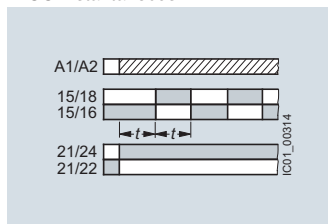

Flashing, symmetrical, starting with interval and instantaneous contact

E

2 CO switched in parallel

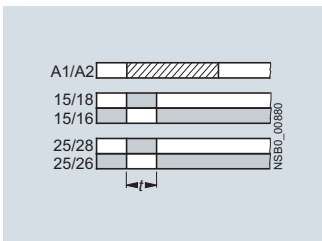

Passing make contact, interval relay

1 CO delayed +
1 CO instantaneous

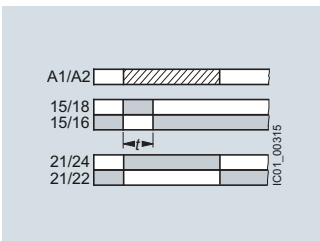

Passing make contact, interval relay and instantaneous contact

F

2 CO switched in parallel

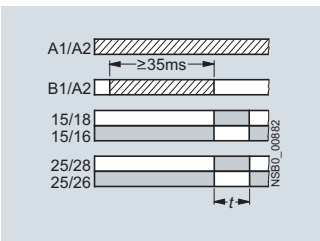

Retriggerable interval relay with deactivated control signal (passing break contact with control signal)

1 CO delayed +
1 CO instantaneous

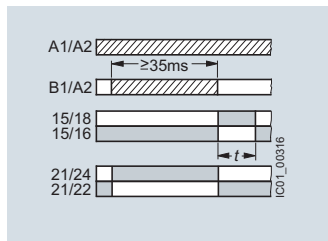

Retriggerable interval relay with deactivated control signal (passing break contact with control signal) and instantaneous contact

G

2 CO switched in parallel

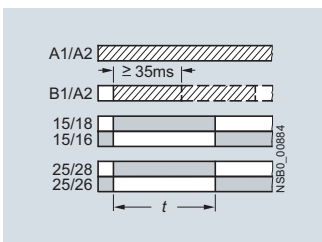

Passing make contact with control signal, not retriggerable (pulse-forming with control signal)

1 CO delayed +
1 CO instantaneous

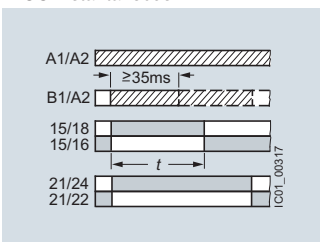

Passing make contact with control signal, not retriggerable (pulse-forming with control signal) and instantaneous contact

H

2 CO switched in parallel

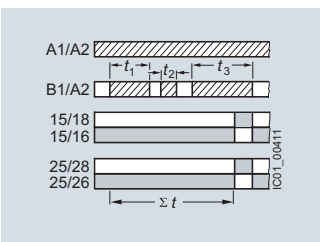

Additive ON-delay, instantaneous OFF with control signal

1 CO delayed +
1 CO instantaneous

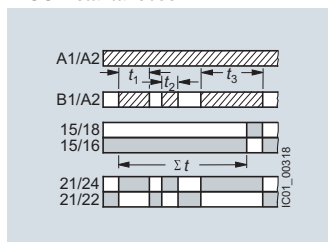

Additive ON-delay, instantaneous OFF with control signal and instantaneous contact

Legend

A ... M identification letters

▨ Timing relay energized

■ Contact closed

□ Contact open

NEW SIRIUS 3RP25 timing relays, 17.5 mm and 22.5 mm

Multifunction 3RP2505-.B, 27 functions, 2 CO (continued)

I

2 CO switched in parallel

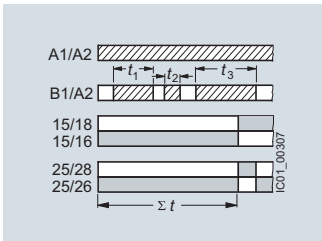

Additive ON-delay with control signal

1 CO delayed +
1 CO instantaneous

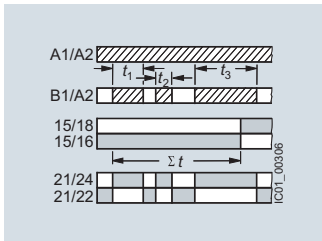

Additive ON-delay with control signal and instantaneous contact

J

2 CO switched in parallel

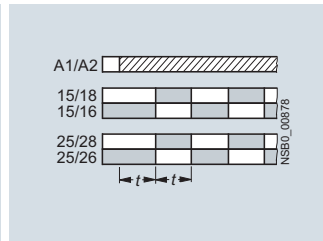

Flashing, symmetrical, starting with pulse

1 CO delayed +
1 CO instantaneous

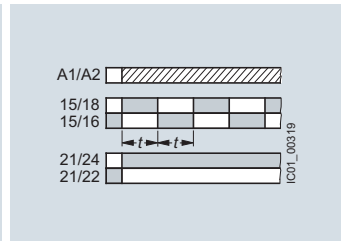

Flashing, symmetrical, starting with pulse and instantaneous contact

K

2 CO switched in parallel

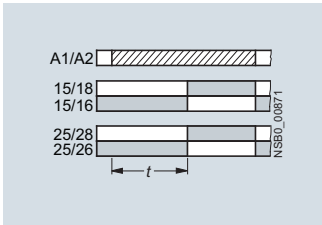

Pulse-delayed (fixed pulse at 1 s and settable pulse delay)

1 CO delayed +
1 CO instantaneous

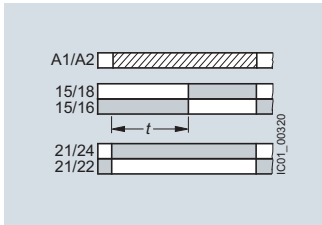

Pulse-delayed (fixed pulse at 1 s and settable pulse delay) and instantaneous contact

L

2 CO switched in parallel

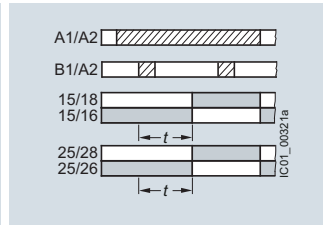

Pulse-delayed with control signal (fixed pulse at 1 s and settable pulse delay)

1 CO delayed +
1 CO instantaneous

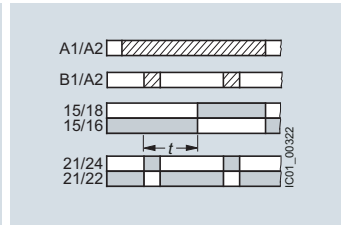

Pulse-delayed with control signal (fixed pulse at 1 s and settable pulse delay) and instantaneous contact

M

2 CO switched in parallel

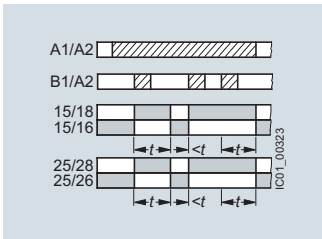

Retriggerable interval relay with activated control signal (watchdog)

1 CO delayed +
1 CO instantaneous

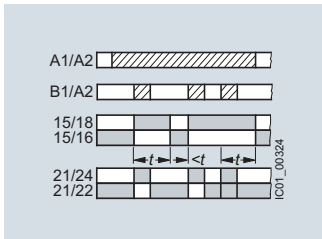

Retriggerable interval relay with activated control signal and instantaneous contact (watchdog)

YΔ

2 CO switched in parallel or
1 CO delayed +
1 CO instantaneous

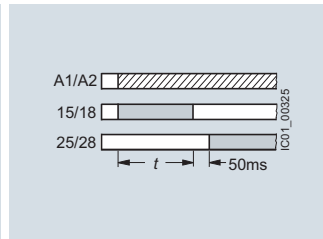

Wye-delta function

Legend

A ... M identification letters

▨ Timing relay energized

■ Contact closed

□ Contact open

Relays

Timing Relays

SIRIUS 3RP25 timing relays, 17.5 mm and 22.5 mm **NEW**

Monofunctions 3RP251.. up to 3RP257.¹⁾

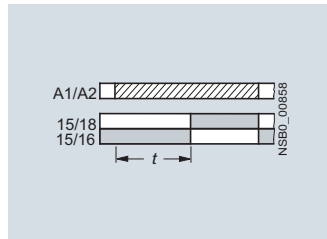

3RP251..-AW30, 1 CO, ON-delay

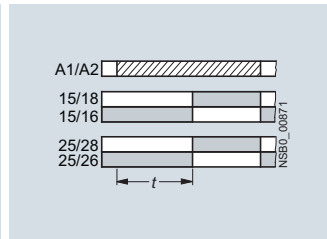

3RP2525..-W30, 2 CO, ON-delay

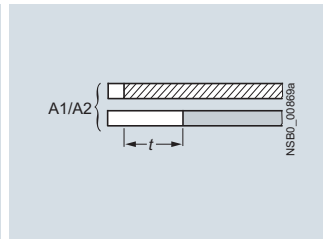

3RP2527..-EW30, 1 NO (semiconductor), ON-delay

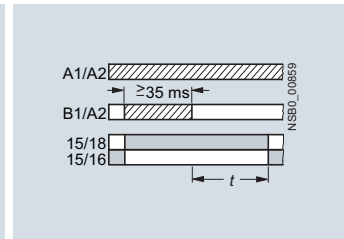

3RP2535..-AW30, 1 CO, OFF-delay with control signal

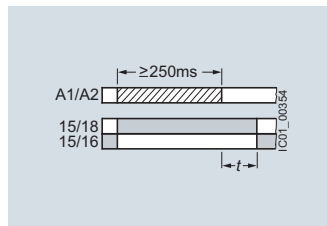

3RP2540..-A.30, 1 CO, OFF-delay (N)¹⁾

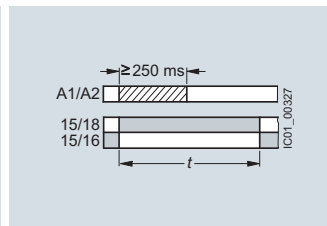

3RP2540..-A.30, 1 CO, positive passing make contact (O)¹⁾

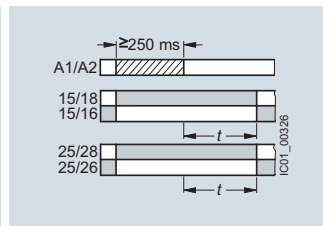

3RP2540..-B.30, 2 CO, OFF-delay (N)¹⁾

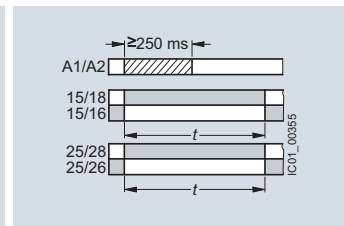

3RP2540..-B.30, 2 CO, positive passing make contact (O)¹⁾

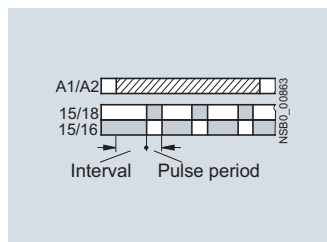

3RP2555..-AW30, 1 CO, flashing, asymmetrical, starting with interval (clock-pulse relay)

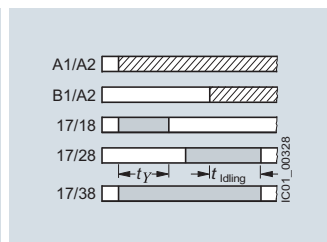

3RP2560..-SW30, 3 NO, wye-delta function with overtravel function (idling)

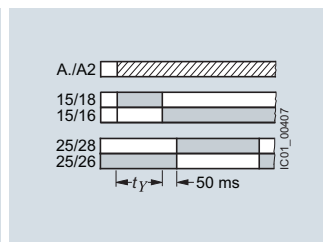

3RP257..-NM20, 2 NO, wye-delta function

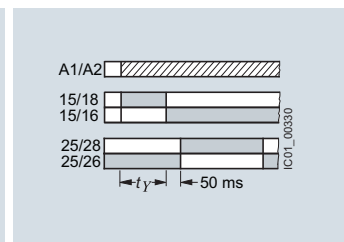

3RP257..-NM30, 2 NO, wye-delta function

Legend

- Timing relay energized
- Contact closed
- Contact open

¹⁾ 3RP2540 has a double function:
Function N = OFF-delay
Function O = positive passing make contact.

NEW SIRIUS 3RP25 timing relays, 17.5 mm and 22.5 mm

Possibilities of operation of the 3RP2560-.SW30 timing relay

Operation 1: Start contact B./A2 is open when control supply voltage A./A2 is applied.

The control supply voltage is applied to A./A2 and there is no control signal on B./A2. This starts the $\Upsilon\Delta$ timing. The idling time (coasting time) is started by applying a control signal to B./A2. When the set time t_{idling} (30 ... 600 s) has elapsed, the output relays (17/16 and 17/28) are reset. If the control signal on B./A2 is switched off (minimum OFF period 270 ms), a new timing is started.

Note:

Observe response time (dead time) of 400 ms on energizing control supply voltage until contacts 17/18 and 17/16 close.

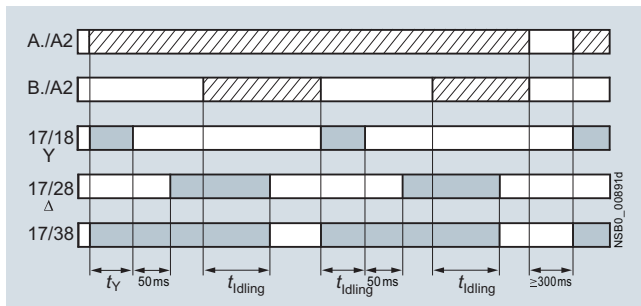

Operation 1

Operation 2: Start contact B./A2 is closed when control supply voltage A./A2 is applied.

If the control signal B./A2 is already present when the control supply voltage A./A2 is applied, **no** timing is started. The timing is only started when the control signal B./A2 is switched off.

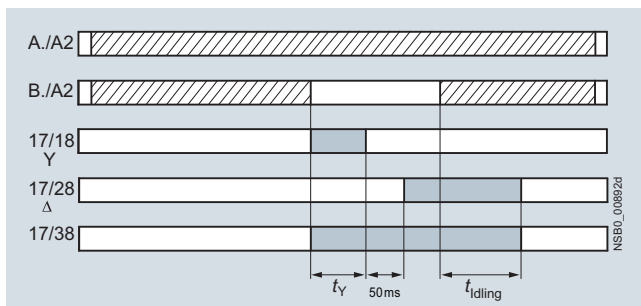

Operation 2

Operation 3: Start contact B./A2 closes while star time is running

If the control signal B./A2 is applied again during the star time, the idling time starts and the timing is terminated normally.

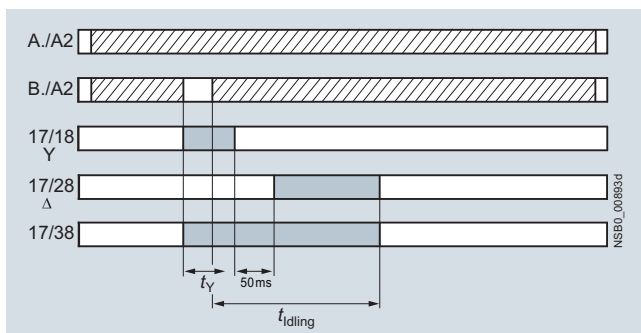

Operation 3

Operation 4: Start contact B./A2 opens while delta time is running and is applied again

If the control signal on B./A2 is applied and switched off again during the delta time, although the idling time has not yet elapsed, the idling time (coasting time) is reset to zero. If the control signal is re-applied to B./A2, the idling time is restarted.

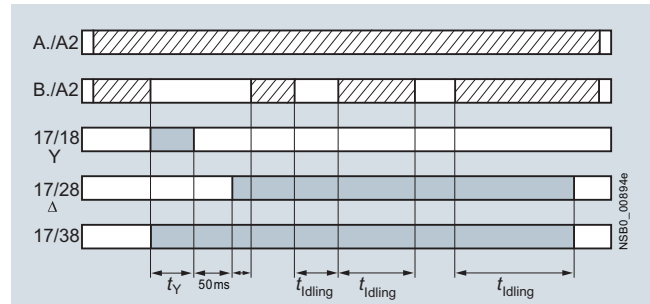

Operation 4

Legend

- Timing relay energized
- Contact closed
- Contact open

t_Y = Star time 1 ... 20 s

t_{idling} = Idling time (coasting time) 30 ... 600 s

Note:

The following applies to all operations: The pressure switch controls the timing via B./A2.

Application example based on standard operation (operation 1): For example, use of 3RP2560 for compressor control

Frequent starting of compressors strains the network, the machine, and the increased costs for the operator. The new timing relay prevents frequent starting at times when there is high demand for compressed air. A special control circuit prevents the compressor from being switched off immediately when the required air pressure in the tank has been reached. Instead, the valve in the intake tube is closed and the compressor runs in "Idling" mode, i.e. in no-load operation for a specific time which can be set from 30 ... 600 s.

If the pressure falls within this time, the motor does not have to be restarted again, but can return to nominal load operation from no-load operation.

If the pressure does not fall within this idling time, the motor is switched off.

The pressure switch controls the timing via B./A2.

The control supply voltage is applied to A./A2 and the start contact B./A2 is open, i.e. there is no control signal on B./A2 when the control supply voltage is applied. The pressure switch signals "too little pressure in system" and starts the timing by way of terminal B./A2. The compressor is started, enters $\Upsilon\Delta$ operation, and fills the pressure tank.

When the pressure switch signals "sufficient pressure", the control signal B./A2 is applied, the idling time (coasting time) is started, and the compressor enters no-load operation for the set period of time from 30 ... 600 s. The compressor is then switched off. The compressor is only restarted if the pressure switch responds again (low pressure).

Relays

Timing Relays

SIRIUS 3RP25 timing relays, 17.5 mm and 22.5 mm **NEW**

Selection and ordering data

PU (UNIT, SET, M) = 1
 PS* = 1 unit
 PG = 41H



3RP2505-2AB30



3RP2505-2BB30



3RP2525-2AW30



3RP2540-2AW30



3RP2555-2AW30



3RP2576-2NW30

Number of NO contacts		Number of CO contacts		Semi-conductor output	Adjustable time		Control supply voltage		DT	Screw terminals		DT	Spring-type terminals (push-in)	
Instantaneous switching	Delayed switching	Instantaneous switching	Delayed switching		At AC 50/60 Hz	At DC	Article No.	Price per PU		Article No.	Price per PU			
					V	V								

3RP2505-.A and 3RP2505-.C timing relays, 13 functions

The functions can be adjusted by means of function selector switches on the device. With a set of foil labels the timing relay can be legibly marked with the functions which can be selected on the timing relay. This is supplied together with the multifunctional timing relay. The same potential must be applied to terminals A. and B. Functions, [see the overview of functions on page 10/44](#)

0	0	0	1	--	0.05 s ... 100 h	24	24	A	3RP2505-1AB30	A	3RP2505-2AB30
						12 ... 240	12 ... 240	A	3RP2505-1AW30	A	3RP2505-2AW30
0	1	0	0	3	0.05 s ... 100 h	12 ... 240	12 ... 240	A	3RP2505-1CW30	A	3RP2505-2CW30

3RP2505-.B timing relay, 27 functions

The functions can be adjusted by means of function selector switches on the device. With a set of foil labels the timing relay can be legibly marked with the functions which can be selected on the timing relay. This is supplied together with the multifunctional timing relay. The same potential must be applied to terminals A. and B. Functions, [see the overview of functions on page 10/44](#)

0	0	1	1	--	0.05 s ... 100 h	24	24	A	3RP2505-1BB30	A	3RP2505-2BB30
						400 ... 440	--	A	3RP2505-1BT20	A	3RP2505-2BT20
						12 ... 240	12 ... 240	A	3RP2505-1BW30	A	3RP2505-2BW30

3RP251. and 3RP252. timing relays, ON-delay

0	0	0	1	--	0.5 ... 10 s	12 ... 240	12 ... 240	A	3RP2511-1AW30	A	3RP2511-2AW30
					1 ... 30 s	12 ... 240	12 ... 240	A	3RP2512-1AW30	A	3RP2512-2AW30
					5 ... 100 s	12 ... 240	12 ... 240	A	3RP2513-1AW30	A	3RP2513-2AW30
					0.05 s ... 100 h	12 ... 240	12 ... 240	A	3RP2525-1AW30	A	3RP2525-2AW30
0	0	0	2	--	0.05 s ... 100 h	24	24	A	3RP2525-1BB30	A	3RP2525-2BB30
						12 ... 240	12 ... 240	A	3RP2525-1BW30	A	3RP2525-2BW30
0	0	0	0	3	0.05 s ... 240 s	12 ... 240	12 ... 240	A	3RP2527-1EW30	A	3RP2527-2EW30

3RP2535 timing relays, OFF-delay with control signal

0	0	0	1	--	0.05 s ... 100 h	12 ... 240	12 ... 240	A	3RP2535-1AW30	A	3RP2535-2AW30
---	---	---	---	----	------------------	------------	------------	---	---------------	---	---------------

3RP2540 timing relays, OFF-delay, without control signal, non-volatile, passing make contact

0	0	0	1	--	0.05 s ... 600 s	24	24	A	3RP2540-1AB30	A	3RP2540-2AB30
						12 ... 240	12 ... 240	A	3RP2540-1AW30	A	3RP2540-2AW30
0	0	0	2	--	0.05 s ... 600 s	24	24	A	3RP2540-1BB30	A	3RP2540-2BB30
						12 ... 240	12 ... 240	A	3RP2540-1BW30	A	3RP2540-2BW30

3RP2555 timing relays, clock-pulse relay, flashing, asymmetrical

0	0	0	1	--	0.05 s ... 100 h	12 ... 240	12 ... 240	A	3RP2555-1AW30	A	3RP2555-2AW30
---	---	---	---	----	------------------	------------	------------	---	---------------	---	---------------

3RP2560 timing relays, wye-delta function with overtravel function (idling)

3	0	0	0	--	1 ... 20 s	12 ... 240	12 ... 240	A	3RP2560-1SW30	A	3RP2560-2SW30
---	---	---	---	----	------------	------------	------------	---	---------------	---	---------------

3RP257. timing relays, wye-delta function

1	1	0	0	--	1 ... 20 s	200 ... 240 ¹⁾	--	A	3RP2574-1NM20	A	3RP2574-2NM20
						12 ... 240	12 ... 240	A	3RP2574-1NW30	A	3RP2574-2NW30
1	1	0	0	--	3 ... 60 s	200 ... 240 ¹⁾	--	A	3RP2576-1NM20	A	3RP2576-2NM20
						12 ... 240	12 ... 240	A	3RP2576-1NW30	A	3RP2576-2NW30

✓ Available, -- Not available

¹⁾ With 3RP2574-.NM20 and 3RP2576-.NM20, connection of 380 ... 440 V AC, 50/60 Hz control voltage is also possible.

For accessories, [see page 10/59](#).

NEW SIRIUS 3RP25 timing relays, 17.5 mm and 22.5 mm

Accessories

Version	DT	Article No.	Price per PU	PU (UNIT, SET, M)	PS*	PG
Accessories for enclosures						
 3ZY1321-1AA00	Sealing covers • 17.5 mm	A	3ZY1321-1AA00	1	5 units	41L
	 3ZY1321-2AA00	• 22.5 mm	A	3ZY1321-2AA00	1	5 units
 3ZY1311-0AA00		Push-in lugs For wall mounting	A	3ZY1311-0AA00	1	10 units
 3ZY1440-0AA00	Coding pins For removable terminals of SIRIUS devices in the industrial standard mounting rail enclosure; enable the mechanical coding of terminals	A	3ZY1440-1AA00	1	12 units	41L
Terminals for SIRIUS devices in the industrial standard mounting rail enclosure						
 3ZY1122-1BA00	Removable terminals • 2-pole, screw terminals 1 x 4 mm ²	A	Screw terminals  3ZY1122-1BA00	1	6 units	41L
	 3ZY1122-2BA00	• 2-pole, push-in terminals 1 x 4 mm ²	A	Spring-type terminals (push-in)  3ZY1122-2BA00	1	6 units
 3RA2908-1A		Screwdrivers For all SIRIUS devices with spring-type terminals; 3.0 mm x 0.5 mm; length approx. 200 mm, titanium gray/black, partially insulated	A	Spring-type terminals  3RA2908-1A	1	1 unit

Relays

Timing Relays

SIRIUS 3RP20 timing relays, 45 mm

Overview

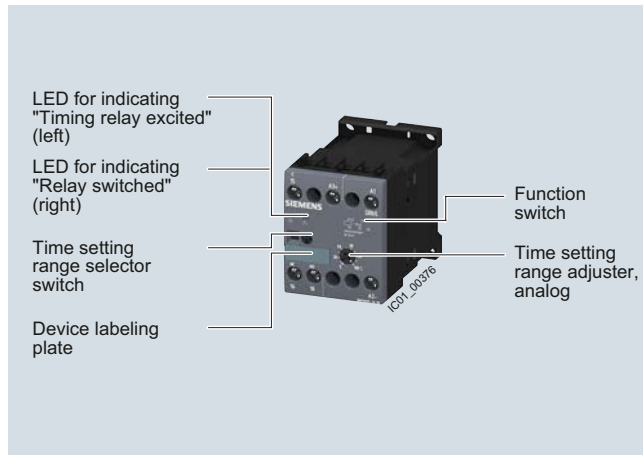

SIRIUS 3RP20 timing relays

SIRIUS 3RP20 electronic timing relays for use in control systems and mechanical engineering with:

- 1 or 2 CO contacts
- Multifunction or monofunction
- Wide voltage range or combination voltage
- Single or selectable time setting ranges
- Switch position indication and voltage indication by LED

Standards

The timing relays comply with:

- IEC 60721-3-3 "Classification of environmental conditions"
- IEC 61812-1 "Time relays for industrial and residential use"
- IEC 61000-6-2 and EN 61000-6-4 "Electromagnetic compatibility"
- IEC 60947-5-1 "Low-voltage switchgear and controlgear – Electromechanical control circuit devices"
- IEC 60947-1, Appendix N "Electrical separation"

Multifunction

The functions of the 3RP2005 multifunctional timing relays can be set by means of the function selector switch. Insert labels clearly and unmistakably. The corresponding labels can be ordered as an accessory. The same potential must be applied to terminals A. and B.

For functions, see 3RP2901 label set, page 10/65.

Note:

The activation of loads parallel to the start input is not permissible when using AC control voltage (see diagrams).

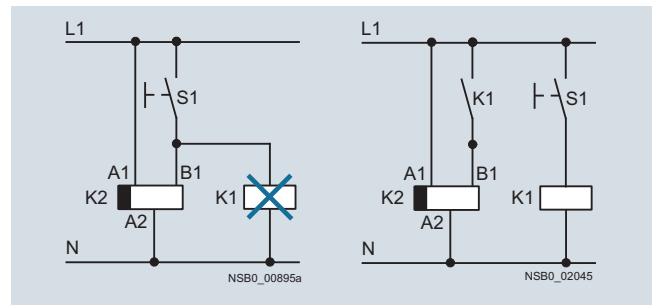

Diagrams

Accessories

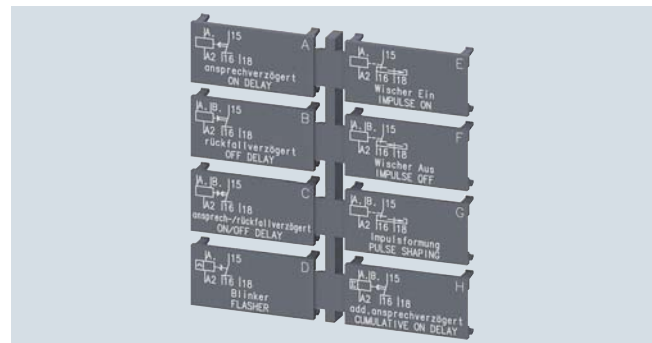

Label set for marking the multifunctional relay

Article No. scheme

Digit of the Article No.	1st - 5th	6th	7th	8th	9th	10th	11th	12th
	□□□□□	□	□	-	□	□	□	0
SIRIUS timing relays, enclosure 45 mm	3 R P 2 0							
Functions/time setting ranges		□	□					
Connection type				□				
Contacts					□			
Rated control supply voltage						□	□	
Example	3 R P 2 0 0 5 - 1 A P 3 0							

Note:

The Article No. scheme is presented here merely for information purposes and for better understanding of the logic behind the article numbers.

For your orders, please use the article numbers quoted in the catalog in the Selection and ordering data.



Benefits

- Suitable for 3RT miniature contactors
- Uniform design
- Ideal for low distance between standard mounting rails and/or for low mounting depth, e.g. in control boxes
- Labels are used on the multifunctional time relay to document the function that has been set

Application

Timing relays are used in control, starting, and protective circuits for all switching operations involving time delays. They guarantee a high level of functionality and a high repeat accuracy of timer settings.

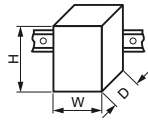
Technical specifications

Type		3RP2005, 3RP2025
Dimensions (W x H x D)	 mm	45 x 57 x 73
Rated insulation voltage Pollution degree 3 Overvoltage category III	V AC	300
Permissible ambient temperature • During operation • During storage	°C °C	-25 ... +60 -40 ... +80
Operating range at excitation¹⁾		0.85 ... 1.1 x U _s at AC; 0.8 ... 1.25 x U _s at DC; 0.95 ... 1.05 times the rated frequency
Mechanical endurance	Operating cycles	10 x 10 ⁶
Electrical endurance at I_e	Operating cycles	1 x 10 ⁵
Connection type		 Screw terminals
• Terminal screw • Solid • Finely stranded with end sleeve • Stranded • AWG cables • Tightening torque	mm ² mm ² mm ² AWG AWG Nm	M3 (for standard screwdriver, size 2 and Pozidriv 2) 2 x (0.5 ... 1.5) ²⁾ , 2 x (0.75 ... 2.5) ²⁾ 2 x (0.5 ... 1.5) ²⁾ , 2 x (0.75 ... 2.5) ²⁾ 2 x (0.5 ... 1.5) ²⁾ , 2 x (0.75 ... 2.5) ²⁾ 2 x (18 ... 14) 0.8 ... 1.2
Connection type		 Spring-type terminals
• Solid • Finely stranded with end sleeve • Finely stranded without end sleeve • AWG cables, solid or stranded • Max. external diameter of the conductor insulation	mm ² mm ² mm ² AWG mm	2 x (0.25 ... 2.5) 2 x (0.25 ... 1.5) 2 x (0.25 ... 2.5) 2 x (24 ... 14) 3.6

1) If nothing else is stated.

2) If two different conductor cross-sections are connected to one clamping point, both cross-sections must lie in one of the ranges specified.

3RP20 internal circuit diagrams

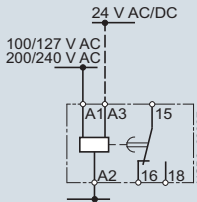
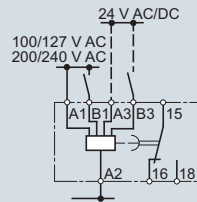
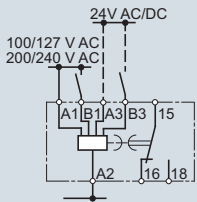
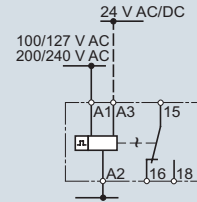
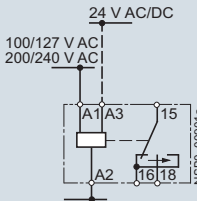
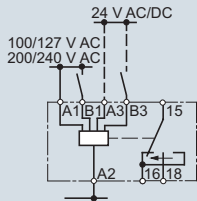
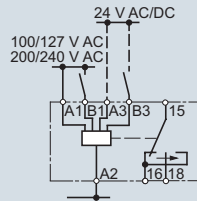
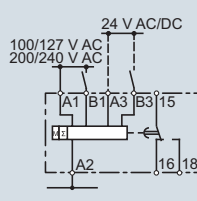
			
<p>3RP2005, 3RP2025 ON-delay</p>	<p>3RP2005 OFF-delay with control signal</p>	<p>3RP2005 ON-delay and OFF-delay with control signal</p>	<p>3RP2005 Flashing, starting with interval</p>
			
<p>3RP2005 Passing make contact</p>	<p>3RP2005 Passing break contact with control signal</p>	<p>3RP2005 Pulse-forming with control signal</p>	<p>3RP2005 Additive ON-delay with control signal</p>

Relays

Timing Relays

SIRIUS 3RP20 timing relays, 45 mm

3RP20 function diagrams and 3RP2901 label set

1 CO contact

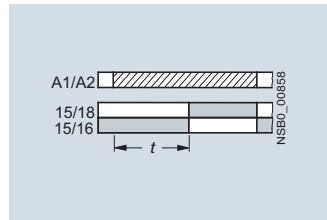

A
3RP2005-.A, 3RP2025
ON-delay

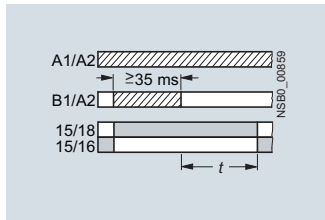

B¹⁾
3RP2005-.A
OFF-delay with control signal

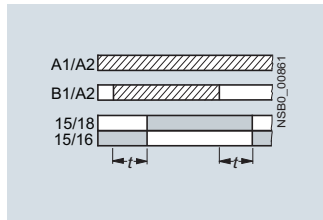

C¹⁾
3RP2005-.A
ON-delay and OFF-delay
with control signal ($t = t_{on} = t_{off}$)

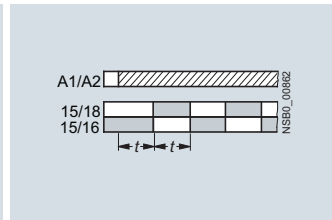

D
3RP2005-.A
Flashing, starting with interval
(pulse/interval 1:1)

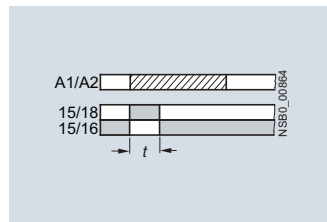

E
3RP2005-.A
Passing make contact

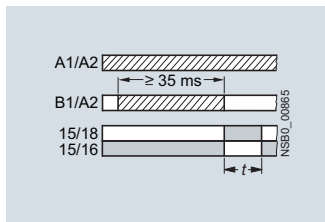

F¹⁾
3RP2005-.A
Passing break contact with
control signal

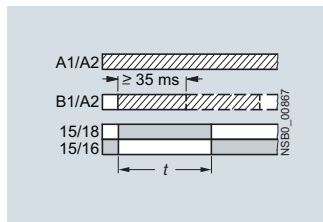

G¹⁾
3RP2005-.A
Pulse-forming with control signal
(pulse generation at the output does
not depend on duration of energizing)

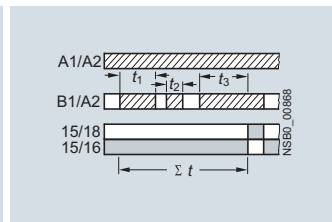

H¹⁾
3RP2005-.A
Additive ON-delay with control signal

Legend

A ... H identification letters for 3RP2005

- Timing relay energized
- Contact closed
- Contact open

¹⁾ Note on function with start contact: A new control signal at terminal B, after the operating time has started, resets the operating time to zero (retriggerable). This does not apply to G, G● and H●, which are not retriggerable.

2 CO contacts

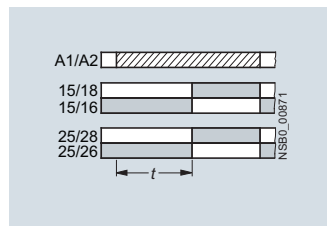

A
3RP2005-.B
ON-delay

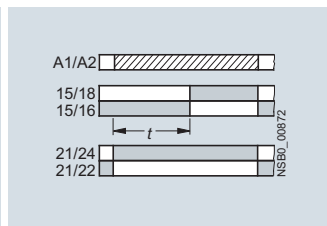

A•
3RP2005-.B
ON-delay and instantaneous contact

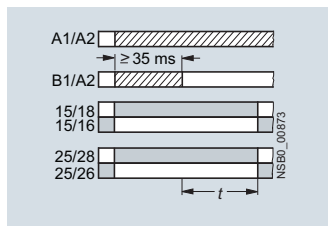

B¹)
3RP2005-.B
OFF-delay with control signal

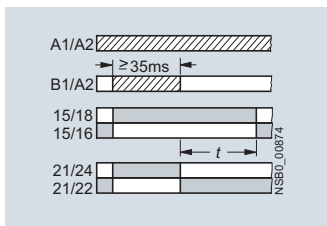

B•¹)
3RP2005-.B
OFF-delay with control signal
and instantaneous contact

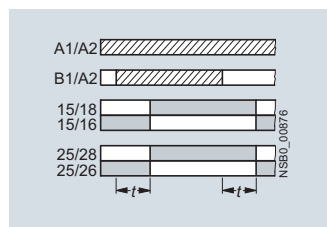

C¹)
3RP2005-.B
ON-delay and OFF-delay
with control signal ($t = t_{on} = t_{off}$)

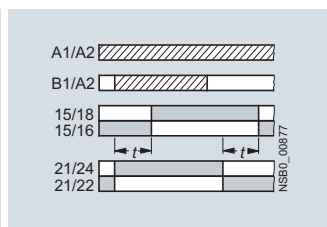

C•¹)
3RP2005-.B
ON-delay and OFF-delay
with control signal and instantaneous
contact ($t = t_{on} = t_{off}$)

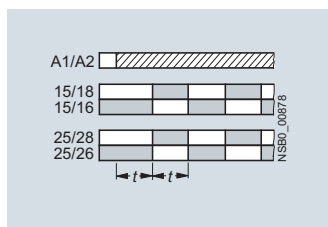

D
3RP2005-.B
Flashing, starting with interval
(pulse/interval 1:1)

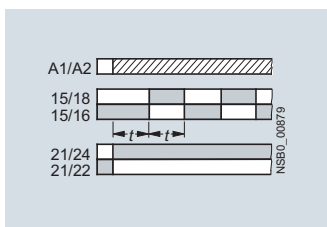

D•
3RP2005-.B
Flashing, starting with interval
(pulse/interval 1:1) and instantaneous
contact

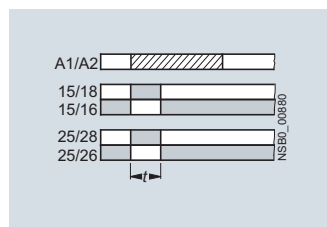

E
3RP2005-.B
Passing make contact

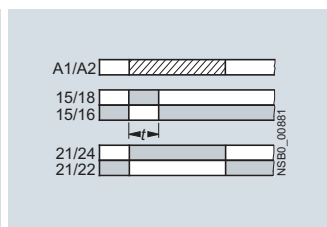

E•
3RP2005-.B
Passing make contact and instantane-
ous contact

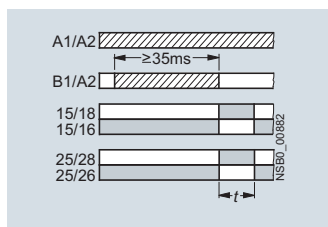

F¹)
3RP2005-.B
Passing break contact with
control signal

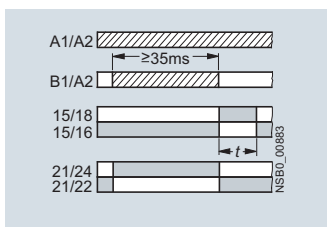

F•¹)
3RP2005-.B
Passing break contact with control
signal and instantaneous contact

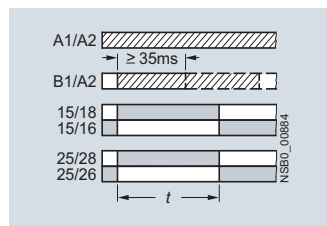

G¹)
3RP2005-.B
Pulse-forming with control signal
(pulse generation at the output does
not depend on duration of energizing)

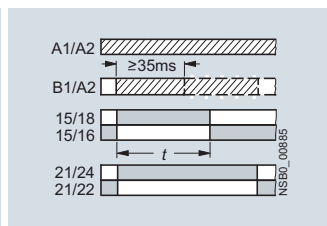

G•¹)
3RP2005-.B
Pulse-forming with control signal
and instantaneous contact (pulse
generation at the output does not
depend on duration of energizing)

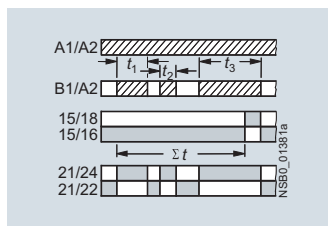

H•¹)
3RP2005-.B
Additive ON-delay with control signal
and instantaneous contact

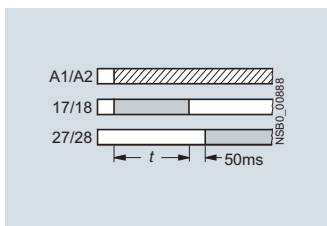

YΔ
3RP2005-.B
Wye-delta function

Legend

A ... H identification letters for 3RP2005

- Timing relay energized
- Contact closed
- Contact open

1) Note on function with start contact: A new control signal at terminal B, after the operating time has started, resets the operating time to zero (retriggerable). This does not apply to G, G• and H•, which are not retriggerable.

Relays

Timing Relays

SIRIUS 3RP20 timing relays, 45 mm

Selection and ordering data

PU (UNIT, SET, M) = 1
 PS* = 1 unit
 PG = 41H



3RP2005-1AP30



3RP2005-1BW30



3RP2005-2AP30



3RP2025-2BW30

Version	Time setting range t	Rated control supply voltage U_s		DT	Screw terminals	DT	Spring-type terminals
		50/60 Hz AC	DC		Article No.	Price per PU	Article No. Price per PU
		V	V				

3RP2005 timing relays, multifunction, 15 time setting ranges

The functions can be adjusted by means of rotary switches. Insert labels can be used to adjust different functions of the 3RP2005 timing relay clearly and unmistakably. The corresponding labels can be ordered as an accessory. The same potential must be applied to terminals A. and B.
 For functions, see 3RP2901 label set, page 10/65.

With LED and 1 CO contact ¹⁾ , 8 functions	0.05 ... 1 s 0.15 ... 3 s 0.5 ... 10 s	24/100 ... 127 24/200 ... 240	24 24	▶ ▶	3RP2005-1AQ30 3RP2005-1AP30	A ▶	3RP2005-2AQ30 3RP2005-2AP30
With LED and 2 CO contacts, 16 functions	1.5 ... 30 s 0.05 ... 1 min 5 ... 100 s 0.15 ... 3 min 0.5 ... 10 min 1.5 ... 30 min 0.05 ... 1 h 5 ... 100 min 0.15 ... 3 h 0.5 ... 10 h 1.5 ... 30 h 5 ... 100 h ∞ ²⁾	24 ... 240 ³⁾	24 ... 240 ⁴⁾	▶	3RP2005-1BW30	A	3RP2005-2BW30

3RP2025. timing relays, ON-delay, 15 time setting ranges

With LED and 1 CO contact ¹⁾	0.05 ... 1 s 0.15 ... 3 s 0.5 ... 10 s 1.5 ... 30 s 0.05 ... 1 min 5 ... 100 s 0.15 ... 3 min 0.5 ... 10 min 1.5 ... 30 min 0.05 ... 1 h 5 ... 100 min 0.15 ... 3 h 0.5 ... 10 h 1.5 ... 30 h 5 ... 100 h ∞ ²⁾	24/100 ... 127 24/200 ... 240	24 24	▶ ▶	3RP2025-1AQ30 3RP2025-1AP30	▶ ▶	3RP2025-2AQ30 3RP2025-2AP30
---	---	----------------------------------	----------	--------	--------------------------------	--------	--------------------------------

For accessories, see page 10/65.

- 1) Units with electrical protective separation.
- 2) With switch position ∞ no timing. For test purposes (ON/OFF function) on site. Relay is constantly on when activated, or relay remains constantly off when activated. Depending on which function is set.
- 3) Operating range 0.8 to 1.1 x U_s .
- 4) Operating range 0.7 to 1.1 x U_s .

Accessories

Version	Function	Identification letter	Use	DT	Article No.	Price per PU	PU (UNIT, SET, M)	PS*	PG
---------	----------	-----------------------	-----	----	-------------	--------------	-------------------	-----	----

Label sets for 3RP20

Accessories for 3RP20 (not included in the scope of supply).
The label set offers the possibility of labeling timing relays with the set function in English and German.



3RP2901-0A

1 label set (1 unit) with 8 functions	ON-delay	A	NEW C	For devices with 1 CO	3RP2901-0A		1	5 units	41H
	OFF-delay with control signal	B							
	ON-delay and OFF-delay with control signal	C							
	Flashing, starting with interval	D							
	Passing make contact	E							
	Passing break contact with control signal	F							
	Pulse-forming with control signal	G							
	Additive ON-delay with control signal	H							



3RP2901-0B

1 label set (1 unit) with 16 functions	ON-delay	A	NEW C	For devices with 2 CO contacts	3RP2901-0B		1	5 units	41H
	OFF-delay with control signal	B							
	ON-delay and OFF-delay with control signal	C							
	Flashing, starting with interval	D							
	Passing make contact	E							
	Passing break contact with control signal	F							
	Pulse-forming with control signal	G							
	ON-delay and instantaneous contact	A•							
	OFF-delay with control signal and instantaneous contact	B•							
	ON-delay and OFF-delay with control signal and instantaneous contact	C•							
	Flashing, starting with interval, and instantaneous contact	D•							
	Passing make contact and instantaneous contact	E•							
	Passing break contact with control signal and instantaneous contact	F•							
	Pulse-forming with control signal and instantaneous contact	G•							
	Additive ON-delay with control signal and instantaneous contact	H•							
	Wye-delta function	YΔ							

Blank inscription labels for 3RP20

Blank labels, 20 mm x 7 mm, pastel turquoise ¹⁾	For 3RP20	D	3RT1900-1SB20	100	340 units	41B
--	-----------	---	----------------------	-----	-----------	-----

¹⁾ PC labeling system for individual inscription of unit labeling plates available from:
murrplastik Systemtechnik GmbH,
see Chapter 16, "Appendix" → "External Partners".

Relays

Timing Relays

7PV15 timing relays in enclosure, 17.5 mm

Overview



7PV15 timing relay

Electronic timing relays for general use and in control systems, mechanical engineering and infrastructure with:

- 1 or 2 CO contacts
- Multifunction or monofunction
- Wide voltage range or combination voltage
- Single or selectable time setting ranges
- Switch position indication and voltage indication by LED

Standards

The timing relays comply with:

- IEC 60721-3-3 "Classification of environmental conditions"
- IEC 61812-1 "Time relays for industrial and residential use"
- IEC 61000-6-2 and EN 61000-6-4 "Electromagnetic compatibility"
- IEC 60947-5-1 "Low-voltage switchgear and controlgear – Electromechanical control circuit devices"
- DIN 43880 "Built-in equipment for electrical installations; overall dimensions and related mounting dimensions"

Multifunction

The functions of the 7PV1508-1A multifunctional timing relays can be set by means of rotary switches. The identification letters A to G are printed on the front alongside the rotary selector switch of the unit. The related function can be found in the form of a bar graph on the side of the device.

Enclosure version

All timing relays are suitable for snap-on mounting onto TH 35 standard mounting rails according to IEC 60715. The enclosure complies with DIN 43880, 1 MW.

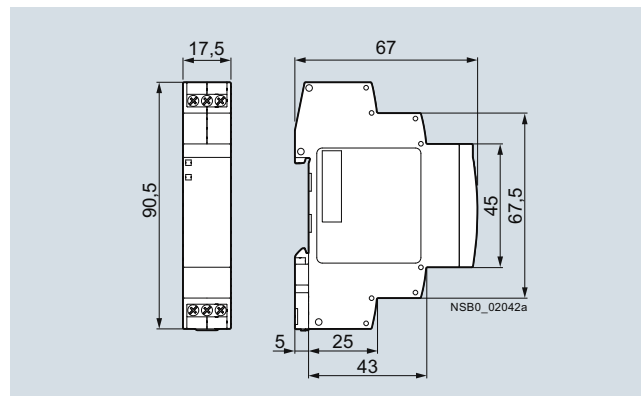

Dimensions

Note:

The activation of loads parallel to the start input is not permissible when using AC control voltage (see diagrams).

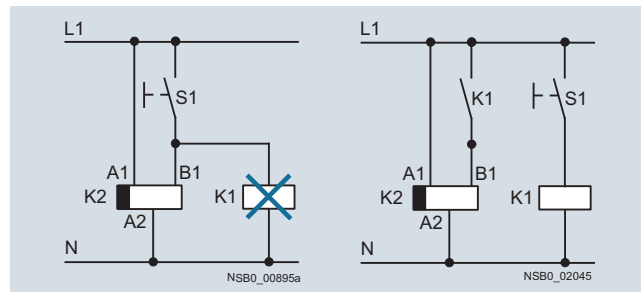

Diagrams

Article No. scheme

Digit of the Article No.	1st - 5th	6th	7th	8th	9th	10th	11th	12th					
	□□□□□	□	□	-	□	□	□	0					
Timing relays in industrial enclosure, 17.5 mm	7 P V 1 5												
Functions/time setting ranges		□	□										
Connection type					□								
Contacts						□							
Rated control supply voltage							□	□					
Example	7	P	V	1	5	0	8	-	1	A	W	3	0

Note:

The Article No. scheme is presented here merely for information purposes and for better understanding of the logic behind the article numbers.

For your orders, please use the article numbers quoted in the catalog in the Selection and ordering data.

Benefits

- Wide voltage range 12 to 240 V AC/DC
- High switching capacity, e.g. AC-15 at 230 V, 3 A
- Combination voltage, e.g. 24 V AC/DC and 200 to 240 V AC
- Changes to the time setting range during operation
- Changes to the function in the de-energized state
- High level of functionality and a high repeat accuracy of timer settings
- Integrated surge suppressor
- Function charts printed on the side of the device for reliable device adjustment

Application

Timing relays are used in control, starting and protective circuits for all switching operations involving time delays, e.g. in non-residential buildings, airports, industrial buildings etc.

Technical specifications

Type	7PV15	
Rated insulation voltage Pollution degree 2, overvoltage category III	V AC	300
Permissible ambient temperature		
• During operation	°C	-25 ... +55
• During storage	°C	-40 ... +70
Operating range at excitation¹⁾		0.85 ... 1.1 x U_s at V AC/DC, 50/60 Hz 0.8 ... 1.25 x U_s 24 V DC 0.95 ... 1.05 times the rated frequency
Rated operational current I_e		
• AC-15 at 24 ... 240 V, 50 Hz	A	3
• DC-13 at		
- 24 V	A	1
- 125 V	A	0.2
Uninterrupted thermal current I_{th}	A	5
Mechanical endurance	Operating cycles	1 x 10 ⁶
Electrical endurance at I_e	Operating cycles	1 x 10 ⁵
Connection type	 Screw terminals	
• Terminal screw		M3 (for standard screwdriver, size 2 and Pozidriv 2)
• Solid	mm ²	1 x (0.2 ... 2.5)
• Finely stranded with end sleeve	mm ²	1 x (0.25 ... 1.5)
• Finely stranded without end sleeve	mm ²	1 x (0.2 ... 1.5)
• AWG cables, solid or stranded	AWG	1 x (24 ... 14)
• Tightening torque	Nm	0.4 ... 0.5

¹⁾ If nothing else is stated.

7PV15 internal circuit diagrams

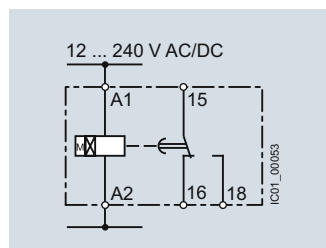

7PV1508-1AW30
ON-delay

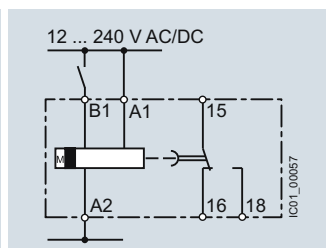

7PV1508-1AW30
OFF-delay

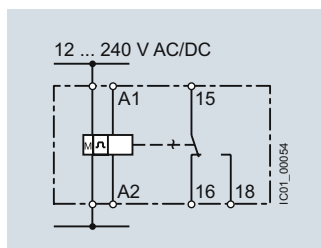

7PV1508-1AW30
Flashing, starting with interval

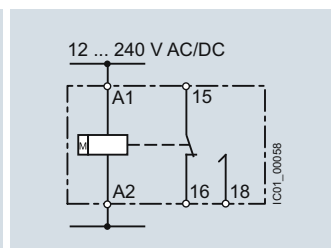

7PV1508-1AW30
Passing make contact

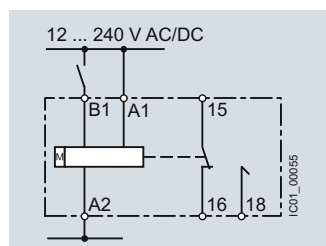

7PV1508-1AW30
Passing break contact
with control signal

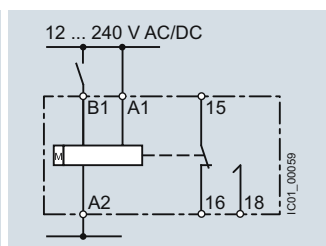

7PV1508-1AW30
Pulse-forming
with control signal

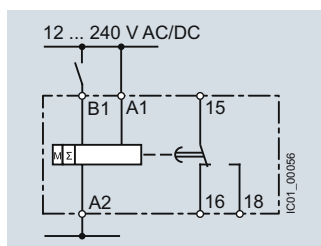

7PV1508-1AW30
Additive ON-delay,
with control signal

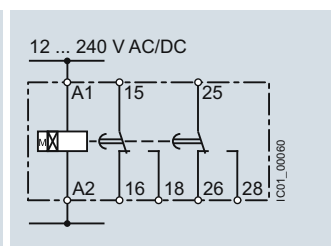

7PV1508-1BW30
ON-delay

Relays

Timing Relays

7PV15 timing relays in enclosure, 17.5 mm

7PV15 internal circuit diagrams (continued)

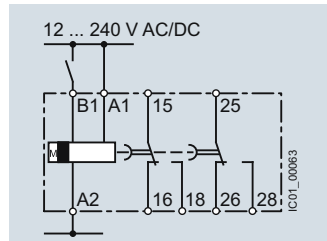

7PV1508-1BW30
OFF-delay
with control signal

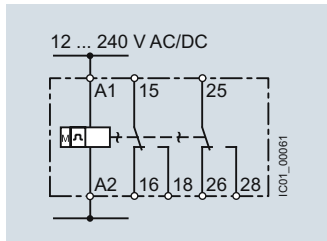

7PV1508-1BW30
Flashing,
starting with interval

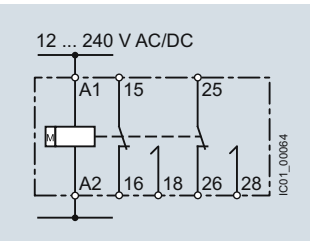

7PV1508-1BW30
Passing make contact

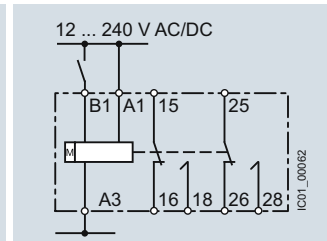

7PV1508-1BW30
Pulse-forming
with control signal

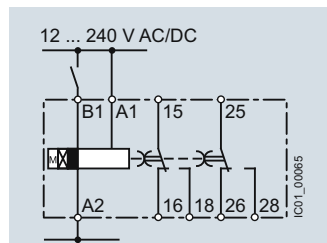

7PV1508-1BW30
ON and OFF-delay

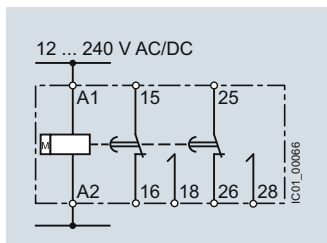

7PV1508-1BW30
Fixed pulse after ON-delay

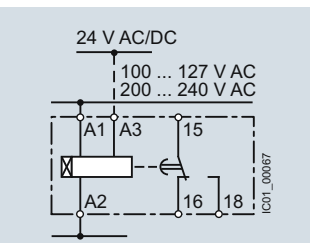

7PV151.-1AQ30, 7PV151.-1AP30
ON-delay

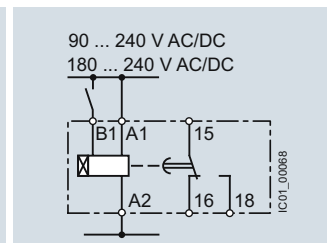

7PV1518-1AJ30, 7PV1518-1AN30
ON-delay

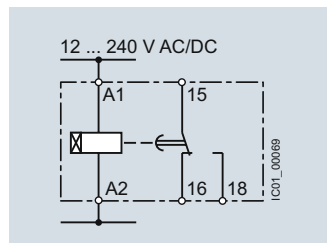

7PV1518-1AW30
ON-delay

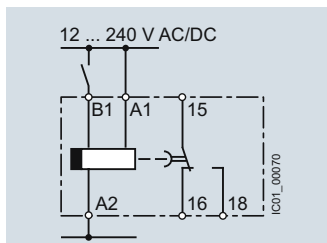

7PV1538-1AW30
OFF-delay
with control signal

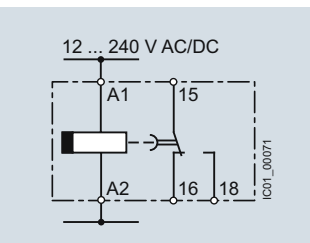

7PV1540-1AW30
OFF-delay
without control signal

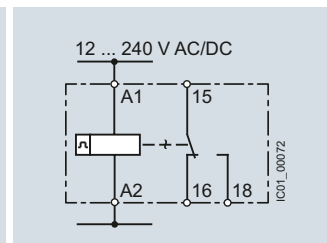

7PV1558-1AW30
Clock-pulse relay

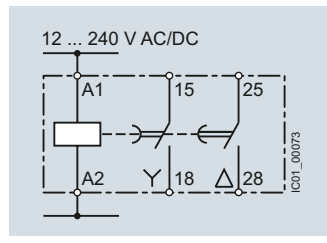

7PV1578-1BW30
Wye-delta

10

7PV15 function diagrams

1 CO contact

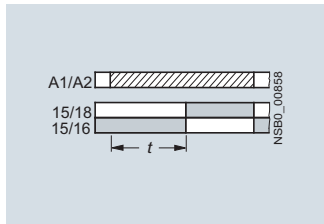

A
7PV1508-1A, 7PV1511, 7PV1512,
7PV1513, 7PV1518
ON-delay

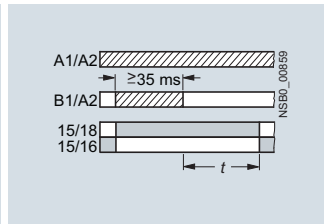

B¹⁾
7PV1508-1A, 7PV1538
OFF-delay with control signal

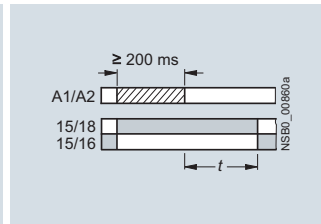

--
7PV1540
OFF-delay without control signal

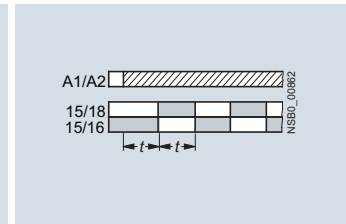

C
7PV1508-1A
Flashing, starting with interval
(pulse/interval 1:1)

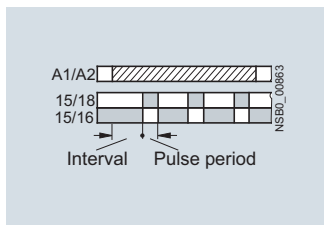

--
7PV1558
Clock-pulse, starting with interval
(dead period, pulse time, and time
setting ranges each separately
adjustable)

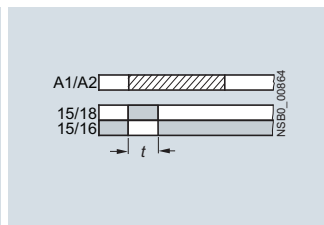

D
7PV1508-1A
Passing make contact

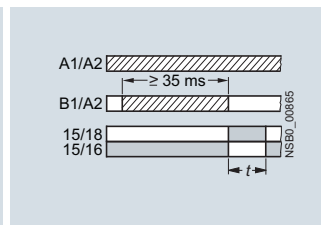

E¹⁾
7PV1508-1A
Passing break contact with
control signal

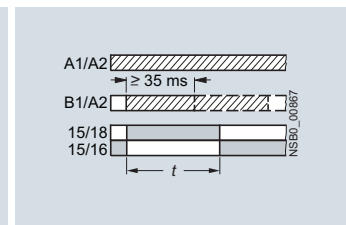

F¹⁾
7PV1508-1A
Pulse-forming with control signal
(pulse generation at the output does
not depend on duration of energizing)

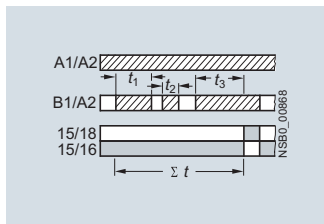

G¹⁾
7PV1508-1A
Additive ON-delay with control signal

Legend

A ... G identification letters for 7PV1508

Timing relay energized

Contact closed

Contact open

¹⁾ Note on function with start contact: A new control signal at terminal B, after the operating time has started, resets the operating time to zero (retriggerable). This does not apply to E, F and G, which are not retriggerable.

Note:

With the 7PV1508-1A multifunctional relay the identification letters A to G are printed on the front alongside the rotary selector switch of the unit. The related function can be found in the form of a bar graph on the side of the device.

Relays

Timing Relays

7PV15 timing relays in enclosure, 17.5 mm

2 CO contacts

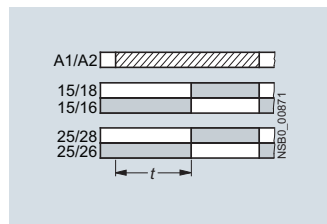

A
7PV1508-1B
ON-delay

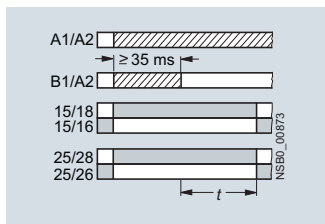

B¹⁾
7PV1508-1B
OFF-delay with control signal

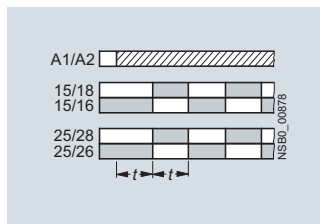

C
7PV1508-1B
Flashing, starting with interval
(pulse/interval 1:1)

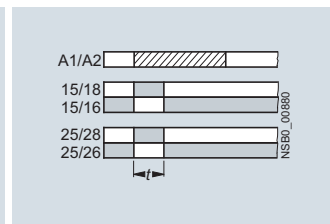

D
7PV1508-1B
Passing make contact

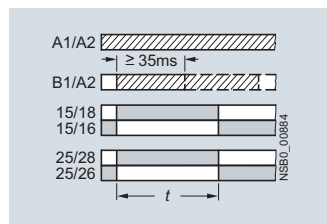

F¹⁾
7PV1508-1B
Pulse-forming with control signal
(pulse generation at the output does not depend on duration of energizing)

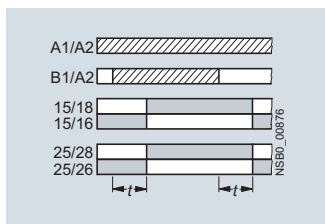

H¹⁾
7PV1508-1B
ON-delay and OFF-delay
with control signal

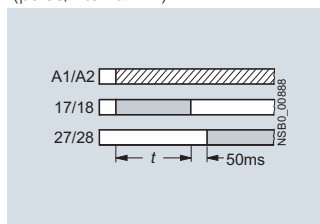

I
7PV1508-1B
Fixed pulse after ON-delay

2 NO contacts

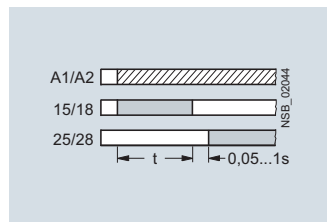

--
7PV1578
Wye-delta function²⁾

Legend

A ... D, F, H, I identification letters for 7PV1508

- Timing relay energized
- Contact closed
- Contact open

¹⁾ Note on function with start contact: A new control signal at terminal B, after the operating time has started, resets the operating time to zero (retriggerable). This does not apply to E, F and G, which are not retriggerable.

²⁾ With 7PV1578 the contacts 16 and 26 are not needed for the wye-delta function.

Note:

With the 7PV1508-1B multifunctional relay the identification letters A to D, F, H, I are printed on the front alongside the rotary selector switch of the unit. The related function can be found in the form of a bar graph on the side of the device.

Selection and ordering data



Version	Time setting range t adjustable by rotary switch to	Rated control supply voltage U_s	DT	Screw terminals	PU (UNIT, SET, M)	PS*	PG
		50/60 Hz AC V	DC V	Article No.	Price per PU		

7PV1508 timing relays, multifunction, 7 time setting ranges

The functions can be adjusted by means of rotary switches. The same potential must be applied to terminals A. and B.

With LED and 1 CO contact, 7 functions	0.05 ... 1 s 0.5 ... 10 s 5 ... 100 s	12 ... 240	12 ... 240	▶	7PV1508-1AW30	1	1 unit	41H
With LED and 2 CO contacts, 7 functions	30 s ... 10 min 3 min ... 1 h 30 min ... 10 h 5 ... 100 h	12 ... 240	12 ... 240	▶	7PV1508-1BW30	1	1 unit	41H

7PV151. timing relays, ON-delay, 1 time setting range

With LED and 1 CO contact	0.05 ... 1 s	24/200 ... 240	24	▶	7PV1511-1AP30	1	1 unit	41H
	0.5 ... 10 s	24/100 ... 127	24	▶	7PV1512-1AQ30	1	1 unit	41H
		24/200 ... 240	24	▶	7PV1512-1AP30	1	1 unit	41H
	5 ... 100 s	24/100 ... 127	24	▶	7PV1513-1AQ30	1	1 unit	41H
24/200 ... 240		24	▶	7PV1513-1AP30	1	1 unit	41H	

7PV1518 timing relays, ON-delay, 7 time setting ranges

With LED and 1 CO contact	0.05 ... 1 s	12 ... 240	12 ... 240	▶	7PV1518-1AW30	1	1 unit	41H
	0.5 ... 10 s	90 ... 127	90 ... 127	▶	7PV1518-1AJ30	1	1 unit	41H
	5 ... 100 s	180 ... 240	180 ... 240	▶	7PV1518-1AN30	1	1 unit	41H
	30 s ... 10 min							
	3 min ... 1 h							
	30 min ... 10 h							
	5 ... 100 h							

7PV1538 timing relays, OFF-delay, with control signal, 7 time setting range

With LED and 1 CO contact	0.05 ... 1 s	12 ... 240	12 ... 240	▶	7PV1538-1AW30	1	1 unit	41H
	0.5 ... 10 s							
	5 ... 100 s							
	30 s ... 10 min							
	3 min ... 1 h							
	30 min ... 10 h							
	5 ... 100 h							

7PV1540 timing relays, OFF-delay, without control signal, 7 time setting ranges

With LED and 1 CO contact	0.05 ... 1 s	12 ... 240	12 ... 240	▶	7PV1540-1AW30	1	1 unit	41H
	0.15 ... 3s							
	0.3 ... 6 s							
	0.5 ... 10 s							
	1.5 ... 30 s							
	3 ... 60 s							
	5 ... 100 s							

7PV1558 timing relays, clock-pulse relay, 7 time setting ranges

With LED and 1 CO contact	0.05 ... 1 s	12 ... 240	12 ... 240	▶	7PV1558-1AW30	1	1 unit	41H
	0.5 ... 10 s							
	5 ... 100 s							
	30 s ... 10 min							
	3 min ... 1 h							
	30 min ... 10 h							
	5 ... 100 h							

7PV1578 timing relays, wye-delta function, 7 time setting ranges

With LED and 2 NO contacts, dead interval 0.05 ... 1 s adjustable	0.05 ... 1 s	12 ... 240	12 ... 240	▶	7PV1578-1BW30	1	1 unit	41H
	0.5 ... 10 s							
	5 ... 100 s							
	30 s ... 10 min							
	3 min ... 1 h							
	30 min ... 10 h							
	5 ... 100 h							

Relays

Timing Relays

SIRIUS 3RT19 timing relays for mounting onto 3RT1 contactors

Overview



SIRIUS 3RT19 timing relay

SIRIUS 3RT19 electronic timing relays for mounting onto contactors with:

- 1 NO and 1 NC or 2 NO
- Monofunction
- Monovoltage
- Single or selectable time setting ranges

Simply by being plugged in place, the SIRIUS 3RT19 timing relays enable different functionalities required for the assembly of starters to be realized in the feeder. At the same time the timing relays for mounting onto contactors reduce the wiring work required within the feeder and save space in the control cabinet.

A protection circuit (varistor) is integrated in each module.

The electronic timing relay with semiconductor output uses two plug-in contacts to actuate the contactor underneath by means of a semiconductor after the set time has elapsed.

The time-delay auxiliary switch is supplied with power directly by two plug-in contacts through the coil terminals of the contactor, in parallel with A1/A2.

The switching state feedback is performed by a mechanical switching state indicator (plunger).

Article No. scheme

Digit of the Article No.	1st - 5th	6th	7th	8th	9th	10th	11th	12th					
	□□□□□	□	□	- □	□	□	□	□					
Time module and contactor control units	3 R T 1 9												
Size		□	□										
Type of accessories and spare parts				□									
Version					□								
Rated control supply voltage						□							
Time setting ranges							□						
Connection type								□					
Example	3	R	T	1	9	2	6	-	2	E	J	1	1

Note:

The Article No. scheme is presented here merely for information purposes and for better understanding of the logic behind the article numbers.

For your orders, please use the article numbers quoted in the catalog in the Selection and ordering data.

SIRIUS 3RT19 timing relays for mounting onto 3RT1 contactors

Technical specifications

According to IEC 61812-1/DIN VDE 0435-2021

Type		Electronic timing relay blocks with semiconductor output 3RT19.6-2C 3RT19.6-2D	Solid-state time-delay auxiliary switch blocks 3RT19.6-2E 3RT19.6-2F 3RT19.6-2G
Rated insulation voltage U_i Pollution degree 3 Overvoltage category III according to DIN VDE 0110	V AC	300	
Permissible ambient temperature • During operation • During storage	°C °C	-25 ... +60 -40 ... +80	
Operating range of excitation		0.8 ... 1.1 x U_s , 0.95 ... 1.05 times the rated frequency	0.85 ... 1.1 x U_s , 0.95 ... 1.05 times the rated frequency
Rated operational currents I_e • Load current • AC-15, 24 ... 400 V, 50 Hz • DC-13, 24 V • DC-13, 125 V • DC-13, 250 V	A A A A A	0.3 for 3RT1916; 0.5 for 3RT1926 -- -- -- --	-- 3 1 0.2 0.1
Mechanical endurance	Operating cycles	100 x 10 ⁶	10 x 10 ⁶
Electrical endurance at I_e	Operating cycles	100 x 10 ⁶	1 x 10 ⁵
Connection type		 Screw terminals	
• Terminal screw • Solid • Finely stranded with end sleeve • AWG cables, solid or stranded • Tightening torque	mm ² mm ² AWG Nm	M3 (for standard screwdriver, size 2 and Pozidriv 2) 1 x (0.5 ... 4)/2 x (0.5 ... 2.5) 1 x (0.5 ... 2.5)/2 x (0.5 ... 1.5) 2 x (20 ... 14) 0.8 ... 1.2	

Relays

Timing Relays

SIRIUS 3RT19 timing relays for mounting onto 3RT1 contactors

3RT19 internal circuit diagrams

Electronic timing relay blocks

For 3RT10 contactors in sizes S0 to S12 and 3RH11 contactor relays

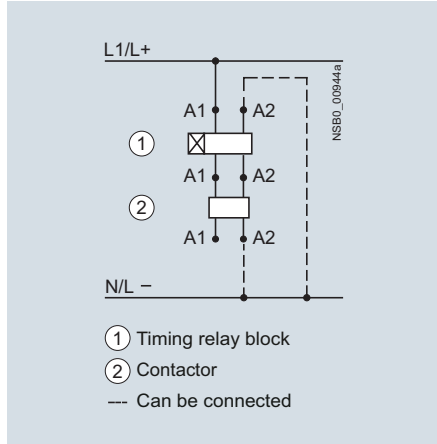

3RT1926-2C
ON-delay

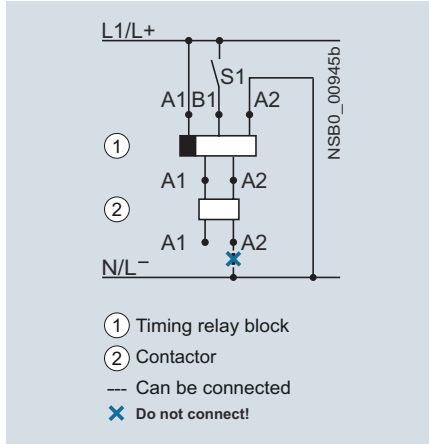

3RT1926-2D
With OFF-delay
(with control signal)

Solid-state time-delay auxiliary switch blocks

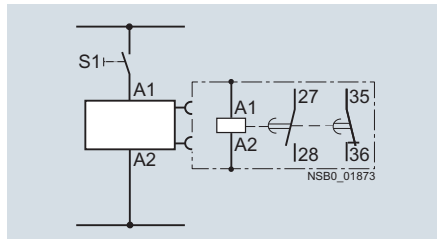

3RT1926-2E
ON-delay

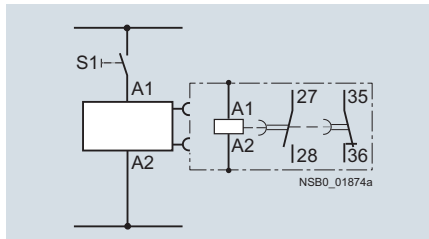

3RT1926-2F
OFF-delay
(without control signal)

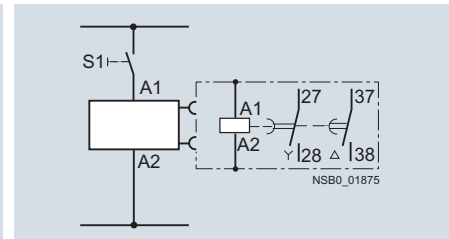

3RT1926-2G
Wye-delta function

3RT1926 function diagrams

1 NO contact + 1 NC contact

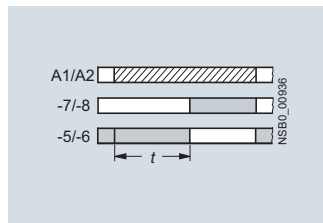

3RT1926-2E
ON-delay

1 NO contact (semiconductor)

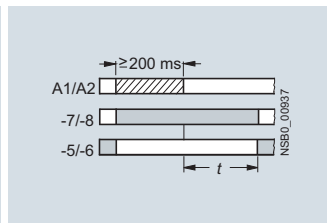

3RT1926-2F
OFF-delay without control signal

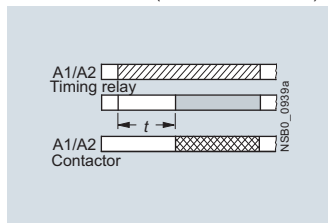

3RT1926-2C
ON-delay
two-wire design (varistor integrated)

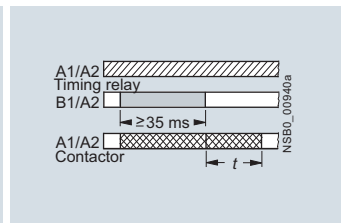

3RT1926-2D
OFF-delay
with control signal (varistor integrated)

2 NO contacts

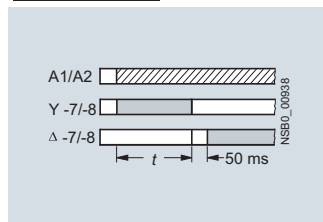

3RT1926-2G
Wye-delta function
1 NO delayed, 1 NO instantaneous,
dead time 50 ms (varistor integrated)

Legend

- Timing relay energized
- Contact closed
- Contact open
- Contactor coil energized

SIRIUS 3RT19 timing relays for mounting onto 3RT1 contactors

Selection and ordering data

For contactors	Version	Time setting range t	Rated control supply voltage U_s	DT	Screw terminals	⊕	PU (UNIT, SET, M)	PS*	PG	
Type		s	V		Article No.	Price per PU				
For sizes S0 to S12¹⁾										
 3RT1926-2...	3RT102, 3RT103, 3RT104	Terminal designations acc. to EN 46199-5								
	• ON-delay									
	1 NO + 1 NC	0.05 ... 1	24 AC/DC	C	3RT1926-2EJ11		1	1 unit	41H	
		0.5 ... 10		▶	3RT1926-2EJ21		1	1 unit	41H	
		5 ... 100		A	3RT1926-2EJ31		1	1 unit	41H	
		0.05 ... 1	100 ... 127 AC	C	3RT1926-2EC11		1	1 unit	41H	
		0.5 ... 10		▶	3RT1926-2EC21		1	1 unit	41H	
		5 ... 100		C	3RT1926-2EC31		1	1 unit	41H	
		0.05 ... 1	200 ... 240 AC	B	3RT1926-2ED11		1	1 unit	41H	
		0.5 ... 10		▶	3RT1926-2ED21		1	1 unit	41H	
		5 ... 100		B	3RT1926-2ED31		1	1 unit	41H	
	• OFF-delay without control signal ²⁾									
	1 NO + 1 NC	0.05 ... 1	24 AC/DC	▶	3RT1926-2FJ11		1	1 unit	41H	
		0.5 ... 10		▶	3RT1926-2FJ21		1	1 unit	41H	
		5 ... 100		▶	3RT1926-2FJ31		1	1 unit	41H	
		0.05 ... 1	100 ... 127 AC	B	3RT1926-2FK11		1	1 unit	41H	
		0.5 ... 10		▶	3RT1926-2FK21		1	1 unit	41H	
		5 ... 100		B	3RT1926-2FK31		1	1 unit	41H	
		0.05 ... 1	200 ... 240 AC	B	3RT1926-2FL11		1	1 unit	41H	
		0.5 ... 10		A	3RT1926-2FL21		1	1 unit	41H	
	5 ... 100		A	3RT1926-2FL31		1	1 unit	41H		
• Wye-delta function (varistor integrated)										
1 NO delayed +	1.5 ... 30	24 AC/DC	▶	3RT1926-2GJ51		1	1 unit	41H		
1 NO instantaneous, dead time		100 ... 127 AC	▶	3RT1926-2GC51		1	1 unit	41H		
50 ms		200 ... 240 AC	▶	3RT1926-2GD51		1	1 unit	41H		
For sizes S0 to S3, with semiconductor output										
3RT102, 3RT103, 3RT104 ²⁾	For mounting onto coil terminals on top of the contactors									
The electrical connection between the relay block and the corresponding contactor is established by screwing the two connecting pins of the timing relay block to coil terminals A1/A2 on top of the contactor.										
• ON-delay, two-wire design (varistor integrated)										
	0.05 ... 1	24 ... 66 AC/DC	B	3RT1926-2CG11		1	1 unit	41H		
	0.5 ... 10		B	3RT1926-2CG21		1	1 unit	41H		
	5 ... 100		B	3RT1926-2CG31		1	1 unit	41H		
	0.05 ... 1	90 ... 240 AC/DC	▶	3RT1926-2CH11		1	1 unit	41H		
	0.5 ... 10		▶	3RT1926-2CH21		1	1 unit	41H		
	5 ... 100		▶	3RT1926-2CH31		1	1 unit	41H		
• OFF-delay with control signal (varistor integrated)										
	0.05 ... 1	24 ... 66 AC/DC	C	3RT1926-2DG11		1	1 unit	41H		
	0.5 ... 10		B	3RT1926-2DG21		1	1 unit	41H		
	5 ... 100		D	3RT1926-2DG31		1	1 unit	41H		
	0.05 ... 1	90 ... 240 AC/DC	B	3RT1926-2DH11		1	1 unit	41H		
	0.5 ... 10		B	3RT1926-2DH21		1	1 unit	41H		
	5 ... 100		C	3RT1926-2DH31		1	1 unit	41H		

¹⁾ The terminals A1 and A2 for the rated control supply voltage of the solid-state time-delay auxiliary switch block must be connected to the corresponding contactor by connecting cables.

²⁾ Not for 3RT104 contactor with 24 to 42 V rated control supply voltage.

Relays

SIRIUS 3RR21, 3RR22 Monitoring Relays for Mounting onto 3RT2 Contactors **NEW**

General data

Overview



Features	3RR21	3RR22	Benefits
General data			
Sizes	S00, S0, S2	S00, S0, S2	<ul style="list-style-type: none"> • Are coordinated with the dimensions, connections and technical characteristics of the other devices in the SIRIUS modular system (contactors, soft starters, etc.) • Permit the mounting of slim-line and compact load feeders in widths of 45 mm (S00 and S0) and 55 mm (S2) • Simplify configuration
Dimensions in mm (W x H x D)	S00: 45 x 79 x 80, S0: 45 x 87 x 91, S2: 55 x 99 x 112	S00: 45 x 79 x 80, S0: 45 x 87 x 91, S2: 55 x 99 x 112	
• Screw terminals			
• Spring-type terminals	S00: 45 x 90 x 80, S0: 45 x 109 x 92, S2: 55 x 99 x 112	S00: 45 x 90 x 80, S0: 45 x 109 x 92, S2: 55 x 99 x 112	
Current range	S00: 1.6 ... 16 A S0: 4 ... 40 A S2: 8 ... 80 A	S00: 1.6 ... 16 A S0: 4 ... 40 A S2: 8 ... 80 A	<ul style="list-style-type: none"> • Is adapted to the other devices in the SIRIUS modular system • Just a single version per size with a wide setting range enables easy configuration
Permissible ambient temperature			
During operation	-25 ... +60 °C	-25 ... +60 °C	<ul style="list-style-type: none"> • Suitable for applications in the control cabinet, worldwide
Monitoring functions			
Current overshoot	✓ (Two-phase)	✓ (Three-phase)	<ul style="list-style-type: none"> • Provides optimum inverse-time delayed protection of loads against excessive temperature rises due to overload • Enables detection of filter blockages or pumping against closed gate valves • Enables drawing conclusions about wear, poor lubrication or other maintenance-relevant phenomena
Current undershoot	✓ (Two-phase)	✓ (Three-phase)	<ul style="list-style-type: none"> • Enables detection of overload due to a slipping or torn belt • Guarantees protection of pumps against dry running • Facilitates monitoring of the functions of resistive loads such as heaters • Permits energy savings through monitoring of no-load operation
Apparent current monitoring	✓	✓ (Selectable)	<ul style="list-style-type: none"> • Precision current monitoring especially in a motor's rated and upper torque range
Active current monitoring	--	✓ (Selectable)	<ul style="list-style-type: none"> • Optimum current monitoring over a motor's entire torque range through the patented combination of power factor and apparent current monitoring
Range monitoring	✓ (Two-phase)	✓ (Three-phase)	<ul style="list-style-type: none"> • Simultaneous monitoring of current overshoot and undershoot with a single device
Phase failure, open circuit	✓ (Two-phase)	✓ (Three-phase)	<ul style="list-style-type: none"> • Minimizes heating of three-phase motors during phase failure through immediate disconnection • Prevents operation of hoisting equipment with reduced load carrying capacity
Phase sequence monitoring	--	✓ (Selectable)	<ul style="list-style-type: none"> • Prevents starting of motors, pumps or compressors in the wrong direction of rotation
Internal ground-fault detection (residual current monitoring)	--	✓ (Selectable)	<ul style="list-style-type: none"> • Provides optimum protection of loads against high-resistance short circuits or ground faults due to moisture, condensed water, damage to the insulation material, etc. • Eliminates the need for additional special equipment • Saves space in the control cabinet • Reduces wiring overhead and costs
Blocking current monitoring	--	✓ (Selectable)	<ul style="list-style-type: none"> • Minimizes heating of three-phase motors when blocked during operation through immediate disconnection • Minimizes mechanical loading of the system by acting as an electronic shear pin

✓ Available

-- Not available

NEW SIRIUS 3RR21, 3RR22 Monitoring Relays for Mounting onto 3RT2 Contactors

General data



Features	3RR21	3RR22	Benefits
Features			
RESET function	✓	✓	<ul style="list-style-type: none"> Allows manual or automatic resetting of the relay Resetting directly on the device or by switching the control supply voltage off and on (remote RESET)
ON-delay time	0 ... 60 s	0 ... 99 s	<ul style="list-style-type: none"> Enables motor starting without evaluation of the starting current Can be used for monitoring motors with lengthy start up
Tripping delay time	0 ... 30 s	0 ... 30 s	<ul style="list-style-type: none"> Permits brief threshold value violations during operation Prevents frequent warnings and disconnections with currents near the threshold values
Operating and indicating elements	LEDs and rotary potentiometers	Displays and buttons	<ul style="list-style-type: none"> For setting the threshold values and delay times For selectable functions For quick and selective diagnostics Displays for permanent display of measured values
Integrated contacts	1 CO contact	1 CO, 1 semiconductor output	<ul style="list-style-type: none"> Enable disconnection of the system or process when there is an irregularity Can be used to output signals
Design of load feeders			
Short-circuit strength up to 100 kA at 690 V (in conjunction with the corresponding fuses or the corresponding motor starter protector)	✓	✓	<ul style="list-style-type: none"> Provides optimum protection of the loads and operating personnel in the event of short circuits due to insulation faults or faulty switching operations
Electrical and mechanical matching to 3RT2 contactors	✓	✓	<ul style="list-style-type: none"> Simplifies configuration Reduces wiring outlay and costs Enables stand-alone installation as well as space-saving direct mounting
Spring-type terminals for main circuit (with S00, S0) and auxiliary circuits	✓ (optional)	✓ (optional)	<ul style="list-style-type: none"> Enables fast connections Permits vibration-resistant connections Enables maintenance-free connections
Other features			
Suitable for single- and three-phase loads	✓	✓	<ul style="list-style-type: none"> Enables the monitoring of single-phase systems through parallel infeed at the contactor or looping the current through the three phase connections
Wide setting ranges	✓	✓	<ul style="list-style-type: none"> Reduce the number of variants Minimize the configuration outlay and costs Minimize storage overheads, storage costs, tied-up capital
Wide voltage supply range	✓ (optional)	✓ (optional)	<ul style="list-style-type: none"> Reduces the number of versions Minimizes the configuring overhead and costs Minimizes storage overhead, storage costs, tied-up capital

✓ Available

Relays

SIRIUS 3RR21, 3RR22 Monitoring Relays for Mounting onto 3RT2 Contactors **NEW**

General data

Possible combinations of 3RR21/3RR22 monitoring relays with 3RT2 contactors

Monitoring relays	Current range	Contactors (type, size, rating)		
		3RT201	3RT202	3RT203
Type	A	S00 3/4/5.5/7.5 kW	S0 5.5/7.5/11/15/18.5 kW	S2 18.5/22/30/37 kW
3RR2.41				
3RR2141	1.6 ... 16	✓	With stand-alone installation support	With stand-alone installation support
3RR2241	1.6 ... 16	✓	With stand-alone installation support	With stand-alone installation support
3RR2.42				
3RR2142	4 ... 40	With stand-alone installation support	✓	With stand-alone installation support
3RR2242	4 ... 40	With stand-alone installation support	✓	With stand-alone installation support
3RR2.43				
3RR2143	8 ... 80	With stand-alone installation support	With stand-alone installation support	✓
3RR2243	8 ... 80	With stand-alone installation support	With stand-alone installation support	✓

✓ Available

Article No. scheme

Digit of the Article No.	1st - 3rd	4th	5th	6th	7th	8th	9th	10th	11th	12th			
	□□□	□	□	□	□	-	□	□	□	□	0		
Monitoring relays	3 R R												
SIRIUS 2nd generation	2												
Type of setting	□												
Type of monitoring relay	□												
Size	□												
Connection methods	□												
Number and type of outputs	□												
Signal type of the control supply voltage	□ □												
Example	3	R	R	2	1	4	1	-	1	A	A	3	0

Note:

The Article No. scheme is presented here merely for information purposes and for better understanding of the logic behind the article numbers.

For your orders, please use the article numbers quoted in the catalog in the Selection and ordering data.

Benefits

Advantages through energy efficiency

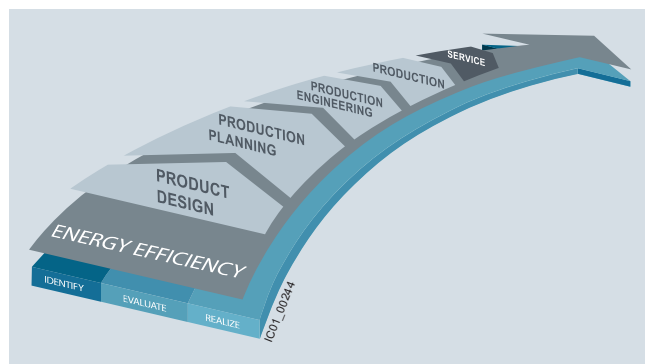

Overview of the energy management process

We offer you a unique portfolio for industrial energy management, using an energy management system that helps to optimally define your energy needs. We split up our industrial energy management into three phases – identify, evaluate, and realize – and we support you with the appropriate hardware and software solutions in every process phase.

The innovative SIRIUS industrial controls products can also make a major contribution to the energy efficiency of a plant (www.siemens.com/sirius/energysaving).

The 3RR2 monitoring relays contribute to the energy efficiency throughout the plant as follows:

- Shutdown in the event of no-load operation (e.g. pump no-load operation)
- Load shedding of predefined loads in the event of current overshoots

More information

Configuration Manual "Configuring SIRIUS Innovations – Selection Data for Fuseless and Fused Load Feeders", see <http://support.automation.siemens.com/WW/view/en/39714188>.

System Manual "Industrial Controls – SIRIUS Innovations", see <http://support.automation.siemens.com/WW/view/en/39740306>.

Manual "3UG45/3UG46 and 3RR21/3RR22 Monitoring Relays", see <http://support.automation.siemens.com/WW/view/en/54397927>.

NEW SIRIUS 3RR21, 3RR22 Monitoring Relays for Mounting onto 3RT2 Contactors

Current and active current monitoring

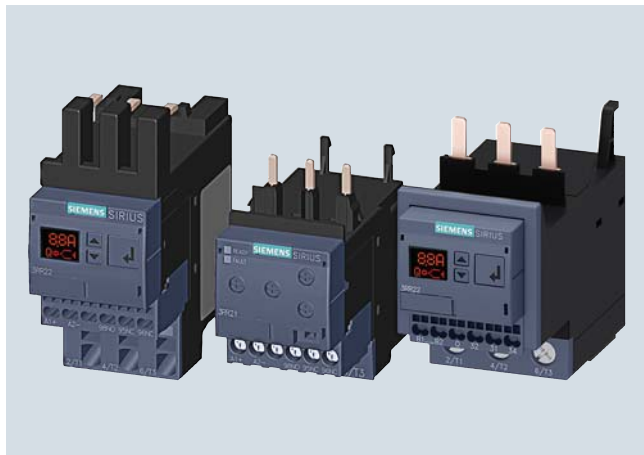
Overview

SIRIUS 3RR2242, 3RR2142 and 3RR2243 current monitoring relays

The SIRIUS 3RR2 current monitoring relays are suitable for the load monitoring of motors or other loads. In two or three phases they monitor the rms value of AC currents for overshooting or undershooting of set threshold values.

Whereas apparent current monitoring is used above all in connection with the rated torque or in case of overload, the active current monitoring option can be used to observe and evaluate the load factor over a motor's entire torque range.

The 3RR2 current monitoring relays can be integrated directly in the feeder by mounting onto the 3RT2 contactor; separate wiring of the main circuit is therefore superfluous. No separate transformers are required.

For a line-oriented configuration or simultaneous use of an overload relay, terminal supports for stand-alone installation are available for separate standard rail mounting.

VersionsBasic versions

The basic versions with two-phase apparent current monitoring, a CO contact output and analog adjustability provide a high level of monitoring reliability especially in the rated and overload range.

Standard versions

The standard versions monitor the current in three phases with selectable active current monitoring. They have additional diagnostics options such as residual current monitoring and phase sequence monitoring, and they are also suitable for monitoring motors below the rated torque. These devices have an additional independent semiconductor output, an actual value indicator, and are digitally adjustable.

Both versions are available optionally with screw or spring-type terminals, in each case for sizes S00 and S0. With variants of size S2 the main current paths always have screw terminals; the control current side can have screw or spring-type terminals.

Note:

In addition to the features of the standard versions, 3RR24 monitoring relays for mounting onto 3RT2 contactors for IO-Link also offer the possibility of transmitting the measured values and diagnostics data to a controller via an IO-Link. Furthermore, the devices can be parameterized on the devices themselves or via IO-Link.

For more information, [see page 10/85](#).

Benefits

- Can be mounted directly on 3RT2 contactors and 3RA23 reversing contactor assemblies, in other words, there is no need for additional wiring in the main circuit
- Optimally coordinated with the technical characteristics of the 3RT2 contactors
- No separate current transformer required
- Versions with wide voltage supply range
- Variably adjustable to overshoot, undershoot or range monitoring
- Freely configurable delay times and RESET response
- Display of ACTUAL value and status messages
- All versions with removable control current terminals
- All versions with screw terminals or spring-type terminals
- Simple determination of the threshold values through direct reference to actually measured values for setpoint loading
- Range monitoring and selectable active current measurement mean that only one device for monitoring a motor is required along the entire torque curve
- In addition to current monitoring it is also possible to monitor for broken cables, phase failure, phase sequence, residual current and motor blocking

Application

- Monitoring of current overshoot and undershoot
- Monitoring of broken conductors
- Monitoring of no-load operation and load shedding, e.g. in the event of a torn V-belt or no-load operation of a pump
- Monitoring of overload, e.g. on conveyor belts or cranes due to an excessive load
- Monitoring the functionality of electrical loads such as heaters
- Monitoring of wrong phase sequence on mobile equipment such as compressors or cranes
- Monitoring of high-impedance faults to ground, e.g. caused by damaged insulation or moisture

Relays

SIRIUS 3RR21, 3RR22 Monitoring Relays for Mounting onto 3RT2 Contactors **NEW**

Current and active current monitoring

Technical specifications

Function charts of 3RR214.-.A.30 basic variants, analogically adjustable

Closed-circuit principle upon application of the control supply voltage

Current overshoot

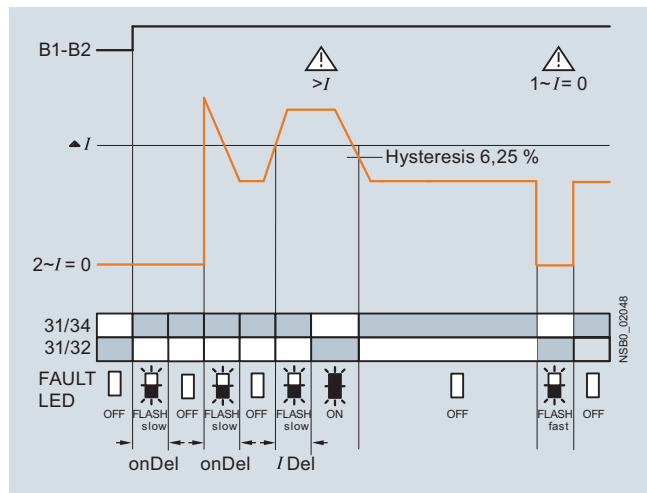

Range monitoring

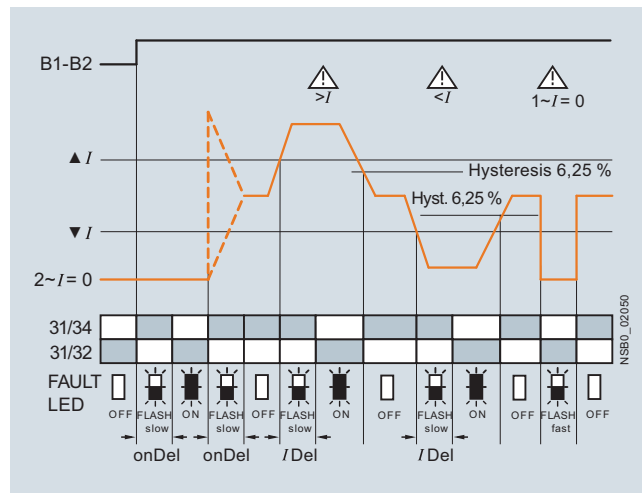

Current undershoot

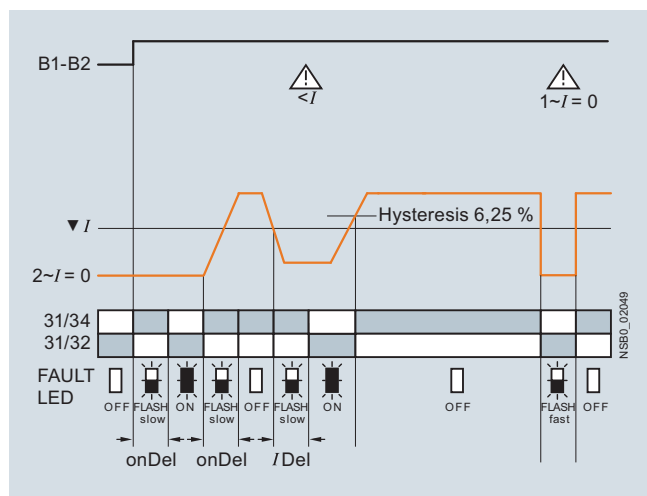

NEW SIRIUS 3RR21, 3RR22 Monitoring Relays for Mounting onto 3RT2 Contactors

Current and active current monitoring

Function charts of 3RR224.-F.30 standard versions, digitally adjustable

With the closed-circuit principle selected upon application of the control supply voltage

Current overshoot

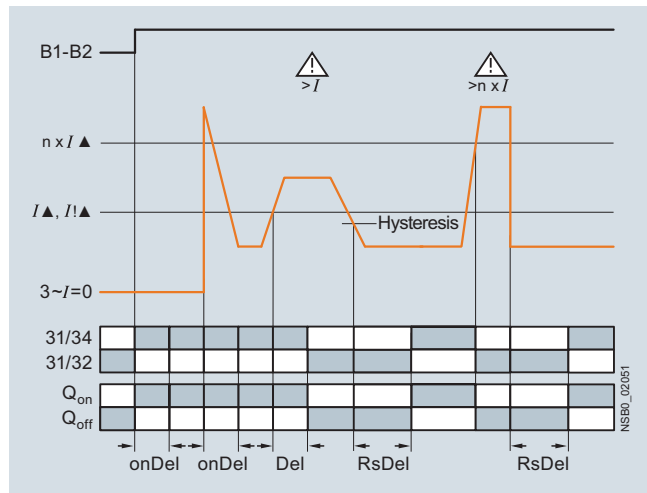

Range monitoring

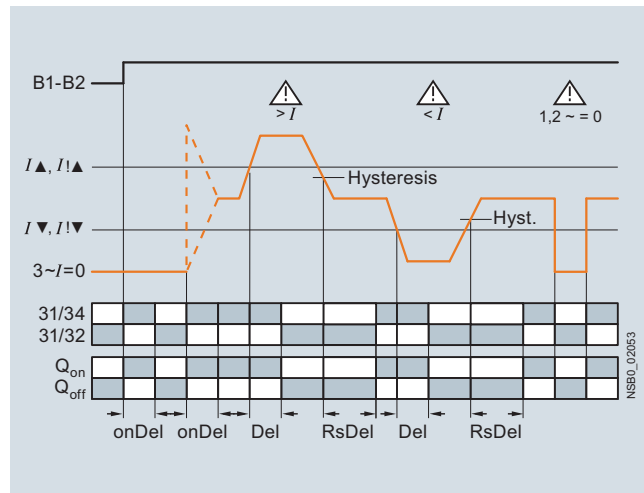

Current undershoot with residual current monitoring

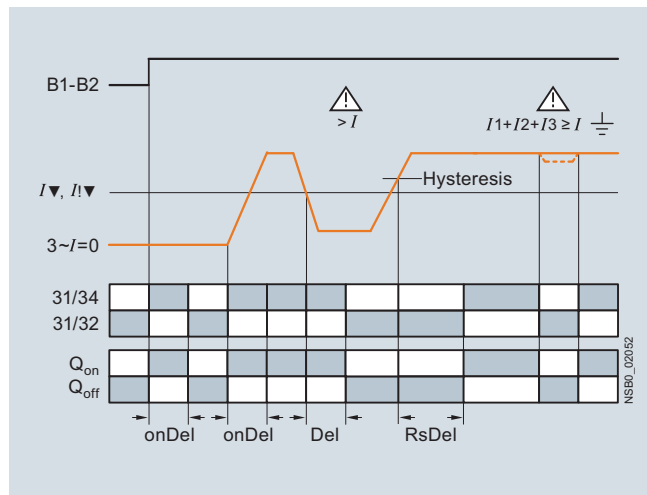

Phase sequence monitoring

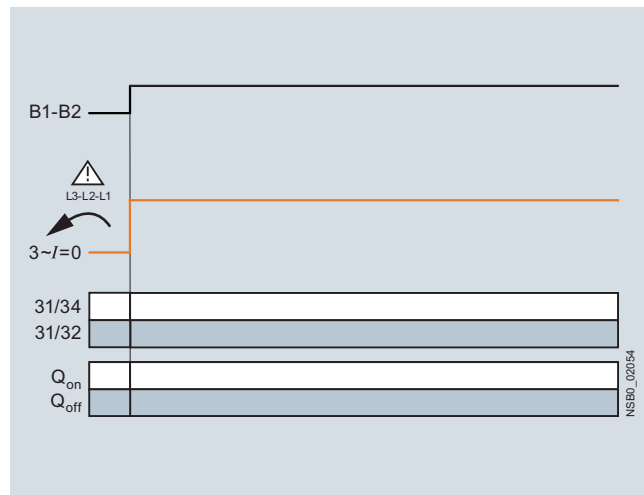

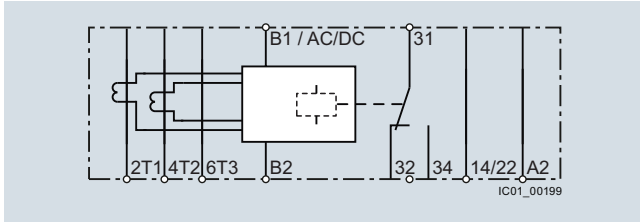
Relays**SIRIUS 3RR21, 3RR22 Monitoring Relays for Mounting onto 3RT2 Contactors** **NEW****Current and active current monitoring****Circuit diagrams**

3RR2141-1A.30

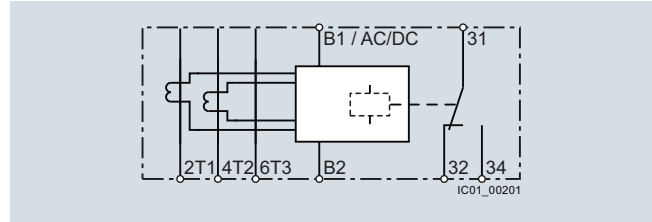

3RR2141-2A.30, 3RR2142-A.30, 3RR2143-A.30

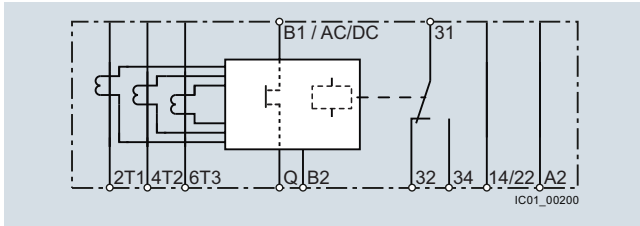

3RR2241-1F.30

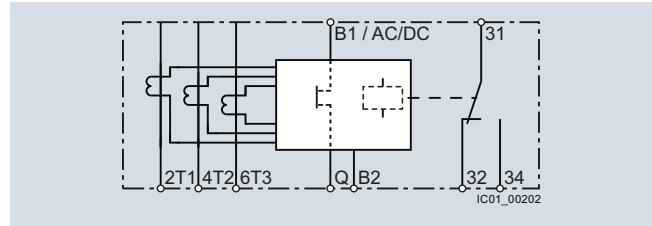

3RR2241-2F.30, 3RR2242-F.30, 3RR2243-F.30

Note:

It is not necessary to protect the measuring circuit for device protection. The protective device for line protection depends on the cross-section used.

NEW SIRIUS 3RR21, 3RR22 Monitoring Relays for Mounting onto 3RT2 Contactors

Current and active current monitoring

Selection and ordering data**SIRIUS 3RR21/3RR22 current monitoring relays**

- For load monitoring of motors or other loads
- Multi-phase monitoring of undercurrent and overcurrent
- Starting and tripping delay can be adjusted separately
- Tripping delay 0 to 30 s
- Auto or Manual RESET

PU (UNIT, SET, M) = 1
 PS* = 1 unit
 PG = 41H



3RR2141-1AW30

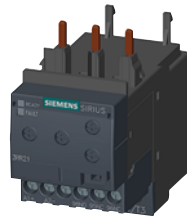

3RR2142-1AW30



3RR2241-1FW30



3RR2242-1FW30



3RR2141-2AA30



3RR2243-3FW30

Size	Measuring range	Hysteresis	Control supply voltage U_s	DT	Screw terminals	DT	Spring-type terminals	
A		A	V		Article No.	Price per PU	Article No.	Price per PU

Basic versions

- Analogically adjustable
- Closed-circuit principle
- 1 CO contact
- 2-phase current monitoring
- Apparent current monitoring
- Start-up delay 0 ... 60 s

S00	1.6 ... 16	6.25 % of threshold value	24 AC/DC 24 ... 240 AC/DC	A A	3RR2141-1AA30 3RR2141-1AW30	A A	3RR2141-2AA30 3RR2141-2AW30
S0	4 ... 40	6.25 % of threshold value	24 AC/DC 24 ... 240 AC/DC	A A	3RR2142-1AA30 3RR2142-1AW30	A A	3RR2142-2AA30 3RR2142-2AW30
S2	8 ... 80	6.25 % of threshold value	24 AC/DC 24 ... 240 AC/DC	NEW A NEW A	3RR2143-1AA30 3RR2143-1AW30	A A	3RR2143-3AA30 3RR2143-3AW30

Standard versions

- Digitally adjustable
- LC display
- Open or closed-circuit principle
- 1 CO contact
- 1 semiconductor output
- 3-phase current monitoring
- Active current or apparent current monitoring
- Phase sequence monitoring
- Residual current monitoring
- Blocking current monitoring
- Reclosing delay time 0 ... 300 min
- Start-up delay 0 ... 99 s
- Separate settings for warning and alarm thresholds









S00	1.6 ... 16	0.1 ... 3	24 AC/DC 24 ... 240 AC/DC	A A	3RR2241-1FA30 3RR2241-1FW30	A A	3RR2241-2FA30 3RR2241-2FW30
S0	4 ... 40	0.1 ... 8	24 AC/DC 24 ... 240 AC/DC	A A	3RR2242-1FA30 3RR2242-1FW30	A A	3RR2242-2FA30 3RR2242-2FW30
S2	8 ... 80	0.2 ... 16	24 AC/DC 24 ... 240 AC/DC	NEW A NEW A	3RR2243-1FA30 3RR2243-1FW30	A A	3RR2243-3FA30 3RR2243-3FW30

Relays

SIRIUS 3RR21, 3RR22 Monitoring Relays for Mounting onto 3RT2 Contactors **NEW**

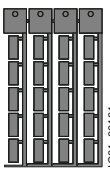
Current and active current monitoring

Accessories

Use	Version	Size	DT	Article No.	Price per PU	PU (UNIT, SET, M)	PS*	PG	
Terminal supports for stand-alone installation¹⁾									
 3RU2916-3AA01	For 3RR21, 3RR22	For separate mounting of the overload relays or monitoring relays; screw and snap-on mounting onto TH 35 standard mounting rail according to IEC 60715				Screw terminals 			
		• Screw connection	S00	▶	3RU2916-3AA01		1	1 unit	41F
			S0	▶	3RU2926-3AA01		1	1 unit	41F
		S2	NEW	3RU2936-3AA01		1	1 unit	41F	
 3RU2926-3AC01		• Spring-type connection		S00	B	Spring-type terminals 			
			S0	B	3RU2916-3AC01		1	1 unit	41F
				3RU2926-3AC01		1	1 unit	41F	
Blank labels									
 3RT2900-1SB20	For 3RR21, 3RR22	Unit labeling plates²⁾ For SIRIUS devices							
		20 mm x 7 mm, titanium gray		D	3RT2900-1SB20		100	340 units	41B
Sealable covers									
 3RR2940	For 3RR21, 3RR22	Sealable covers For securing against unintentional or unauthorized adjustment of settings		A	3RR2940		1	5 units	41H
		For 3RR21	Sealing foil For securing against unauthorized adjustment of setting knobs		▶	3TK2820-0AA00		1	1 unit
Tools for opening spring-type terminals									
 3RA2908-1A	For auxiliary circuit connections	Screwdrivers For all SIRIUS devices with spring-type terminals; 3.0 mm x 0.5 mm; length approx. 200 mm, titanium gray/black, partially insulated		A	Spring-type terminals 				
				3RA2908-1A		1	1 unit	41B	

¹⁾ The accessories are identical to those of the 3RU21 thermal overload relays and the 3RB3 electronic overload relays, see Chapter 7 "Protection Equipment".

²⁾ PC labeling system for individual inscription of unit labeling plates available from: murrplastik Systemtechnik GmbH, see Chapter 16, "Appendix" → "External Partners".

Overview



Features

3RR24

Benefits

General data

Sizes

Dimensions in mm
(W x H x D)

Screw terminals

- Spring-type terminals

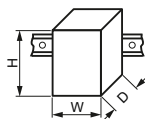

S00, S0, S2

S00: 45 x 79 x 80,
S0: 45 x 87 x 91,
S2: 55 x 99 x 112S00: 45 x 90 x 80,
S0: 45 x 109 x 92,
S2: 55 x 99 x 112

- Are coordinated with the dimensions, connections and technical characteristics of the other devices in the SIRIUS modular system (contactors, soft starters, etc.)
- Permit the mounting of slim-line and compact load feeders in widths of 45 mm (S00 and S0) and 55 mm (S2)
- Simplify configuration

Current range

S00: 1.6 ... 16 A
S0: 4 ... 40 A
S2: 8 ... 80 A

- Is adapted to the other devices in the SIRIUS modular system
- Just a single version per size with a wide setting range enables easy configuration

Permissible ambient temperature

During operation

-25 ... +60 °C

- Suitable for applications in the control cabinet, worldwide

Monitoring functions

Current overshoot

✓
(Three-phase)

- Provides optimum inverse-time delayed protection of loads against excessive temperature rises due to overload
- Enables detection of filter blockages or pumping against closed gate valves
- Enables drawing conclusions about wear, poor lubrication or other maintenance-relevant phenomena

Current undershoot

✓
(Three-phase)

- Enables detection of overload due to a slipping or torn belt
- Guarantees protection of pumps against dry running
- Facilitates monitoring of the functions of resistive loads such as heaters
- Permits energy savings through monitoring of no-load operation

Apparent current monitoring

✓
(Selectable)

- Precision current monitoring especially in a motor's rated and upper torque range

Active current monitoring

✓
(Selectable)

- Optimum current monitoring over a motor's entire torque range through the patented combination of power factor and apparent current monitoring

Range monitoring

✓
(Three-phase)

- Simultaneous monitoring of current overshoot and undershoot with a single device

Phase failure, open circuit

✓
(Three-phase)

- Minimizes heating of three-phase motors during phase failure through immediate disconnection
- Prevents operation of hoisting equipment with reduced load carrying capacity

Phase sequence monitoring

✓
(Selectable)

- Prevents starting of motors, pumps or compressors in the wrong direction of rotation

Internal ground-fault detection
(residual current monitoring)✓
(Selectable)

- Provides optimum protection of loads against high-resistance short circuits or ground faults due to moisture, condensed water, damage to the insulation material, etc.
- Eliminates the need for additional special equipment
- Saves space in the control cabinet
- Reduces wiring overhead and costs

Blocking current monitoring

✓
(Selectable)

- Minimizes heating of three-phase motors when blocked during operation through immediate disconnection
- Minimizes mechanical loading of the system by acting as an electronic shear pin

Operating hours counter

✓

- Gives the time during which there was a measurable current in at least 2 current paths
- As an indicator for upcoming maintenance or replacement of machine and system components

Operating cycles counter

✓

- Is incremented by one each time a breaking operation is detected, in other words a transition from three-phase current flow to no measurable current flow
- As an indicator for upcoming maintenance or replacement of contact blocks

✓ Available

Relays

SIRIUS 3RR24 Monitoring Relays for Mounting onto 3RT2 Contactors for IO-Link **NEW**

General data



Features	3RR24	Benefits
Features		
RESET function	✓	<ul style="list-style-type: none"> Allows manual or automatic resetting of the relay Resetting directly on the device, by switching the control supply voltage off and on or via IO-Link (remote RESET)
ON-delay time	0 ... 999.9 s	<ul style="list-style-type: none"> Enables motor starting without evaluation of the starting current Can be used for monitoring motors with lengthy start up
Tripping delay time	0 ... 999.9 s	<ul style="list-style-type: none"> Permits brief threshold value violations during operation Prevents frequent warnings and disconnections with currents near the threshold values
Operating and indicating elements	Displays and buttons	<ul style="list-style-type: none"> For setting the threshold values and delay times For selectable functions For quick and selective diagnostics Displays for permanent display of measured values
Integrated contacts	1 CO contact, 1 semiconductor output (in SIO mode)	<ul style="list-style-type: none"> Enable disconnection of the system or process when there is an irregularity Can be used to output signals
Design of load feeders		
Short-circuit strength up to 100 kA at 690 V (in conjunction with the corresponding fuses or the corresponding motor starter protector)	✓	<ul style="list-style-type: none"> Provides optimum protection of the loads and operating personnel in the event of short circuits due to insulation faults or faulty switching operations
Electrical and mechanical matching to 3RT2 contactors	✓	<ul style="list-style-type: none"> Simplifies configuration Reduces wiring outlay and costs Enables stand-alone installation as well as space-saving direct mounting
Spring-type terminals for main circuit (with S00, S0) and auxiliary circuits	✓ (Optional)	<ul style="list-style-type: none"> Enables fast connections Permits vibration-resistant connections Enables maintenance-free connections
Other features		
Suitable for single- and three-phase loads	✓	<ul style="list-style-type: none"> Enables the monitoring of single-phase systems through parallel infeed at the contactor or looping the current through the three phase connections
Wide setting ranges	✓	<ul style="list-style-type: none"> Reduce the number of variants Minimize the configuration outlay and costs Minimize storage overheads, storage costs, tied-up capital
Power supply	24 V DC	<ul style="list-style-type: none"> Direct via IO-Link master or via an external auxiliary voltage independent of the IO-Link Minimizes the configuring overhead and costs

✓ Available

NEW SIRIUS 3RR24 Monitoring Relays for Mounting onto 3RT2 Contactors for IO-Link

General data

Possible combinations of 3RR24 monitoring relays with 3RT2 contactors for IO-Link

Monitoring relays	Current range	Contactors (type, size, rating)		
		3RT201 S00 3/4/5.5/7.5 kW	3RT202 S0 5.5/7.5/11/15/18.5 kW	3RT203 S2 18.5/22/30/37 kW
Type	A			
3RR2441	1.6 ... 16	✓	With stand-alone installation support	With stand-alone installation support
3RR2442	4 ... 40	With stand-alone installation support	✓	With stand-alone installation support
3RR2443	8 ... 80	With stand-alone installation support	With stand-alone installation support	✓

✓ Available

Notes:

Devices required for the communication via IO-Link:

- Any controller that supports the IO-Link (e.g. ET 200SP with CPU or S7-1200), see [Catalog ST 70 "Products for Totally Integrated Automation"](#)
- IO-Link-Master (e.g. CM 4xIO-Link for SIMATIC ET 200SP or SM 1278 for S7-1200), see [Catalog ST 70 "Products for Totally Integrated Automation"](#)

Each monitoring relay requires an IO-Link channel.

Article No. scheme

Digit of the Article No.	1st - 3rd	4th	5th	6th	7th	8th	9th	10th	11th	12th	
	□□□	□	□	□	□	-	□	□	□	□	0
Monitoring relays	3 R R										
SIRIUS 2nd generation		2									
Type of setting			□								
Type of monitoring relay				□							
Size					□						
Connection methods						□					
Number and type of outputs							□				
Signal type of the control supply voltage								□	□		
Example	3 R R	2	4	4	1	-	1	A	A	4	0

Note:

The Article No. scheme is presented here merely for information purposes and for better understanding of the logic behind the article numbers.

For your orders, please use the article numbers quoted in the catalog in the Selection and ordering data.

Relays

SIRIUS 3RR24 Monitoring Relays for Mounting onto 3RT2 Contactors for IO-Link **NEW**

General data

Benefits

Advantages through energy efficiency

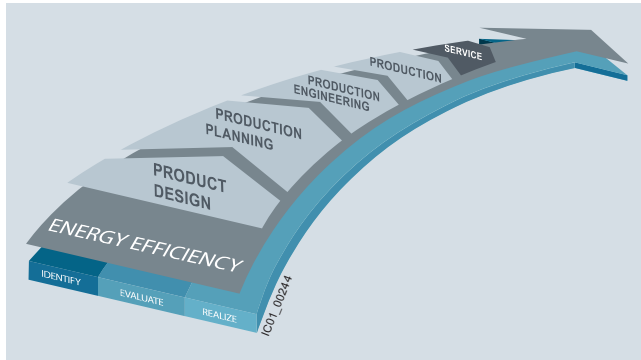

Overview of the energy management process

We offer you a unique portfolio for industrial energy management, using an energy management system that helps to optimally define your energy needs. We split up our industrial energy management into three phases – identify, evaluate, and realize – and we support you with the appropriate hardware and software solutions in every process phase.

The innovative SIRIUS industrial controls products can also make a major contribution to the energy efficiency of a plant (www.siemens.com/sirius/energysaving).

The 3RR2 monitoring relays contribute to the energy efficiency throughout the plant as follows:

- Shutdown in the event of no-load operation (e.g. pump no-load operation)
- Load shedding of predefined loads in the event of current overshoots

More information

Configuration Manual "Configuring SIRIUS Innovations – Selection Data for Fuseless and Fused Load Feeders", see <http://support.automation.siemens.com/WW/view/en/39714188>.

System Manual "Industrial Controls – SIRIUS Innovations", see <http://support.automation.siemens.com/WW/view/en/39740306>.

Manual "3UG48/3RR24 Monitoring Relays for IO-Link", see <http://support.automation.siemens.com/WW/view/en/54375430>.

Notes on safety

System networking requires suitable protective measures (including network segmentation for IT security) in order to ensure safe plant operation.

More information about the subject of Industrial Security, see www.siemens.com/industrialsecurity.

NEW SIRIUS 3RR24 Monitoring Relays for Mounting onto 3RT2 Contactors for IO-Link

Current and active current monitoring

Overview



SIRIUS 3RR2441, 3RR2442 and 3RR2443 current monitoring relays

The SIRIUS 3RR24 current monitoring relays for IO-Link are suitable for the load monitoring of motors or other loads. In three phases they monitor the rms value of AC currents for overshooting or undershooting of set threshold values.

Whereas apparent current monitoring is used above all in connection with the rated torque or in case of overload, the active current monitoring option, which is also selectable, can be used to observe and evaluate the load factor over a motor's entire torque range.

The 3RR24 current monitoring relays for IO-Link can be integrated directly in the feeder by mounting onto the 3RT2 contactor; separate wiring of the main circuit is therefore superfluous. No separate transformers are required.

For a line-oriented configuration or simultaneous use of an overload relay, terminal supports for stand-alone installation are available for separate standard rail mounting.

The SIRIUS 3RR24 current monitoring relays for IO-Link also offer many other options based upon the monitoring functions of the conventional SIRIUS 3RR2 monitoring relays:

- Measured value transmission to a controller, including resolution and unit, may be parameterizable as to which value is cyclically transmitted
- Transmission of alarm flags to a controller
- Full diagnosis capability by inquiry as to the cause of the fault in the diagnosis data record
- Remote parameterization is also possible, in addition to or instead of local parameterization

- Rapid parameterization of the same devices by duplication of the parameterization in the controller
- Parameter transmission by upload to a controller by IO-Link call or by parameter server (if IO-Link master from IO-Link Specification V 1.1 and higher is used)
- Consistent central data storage in the event of parameter change locally or via a controller
- Automatic reparameterizing when devices are exchanged
- Blocking of local parameterization via IO-Link possible
- Faults are saved in parameterizable and non-volatile fashion to prevent an automatic start up after voltage failure and to make sure diagnostics data is not lost
- By integration into the automation level the option exists of parameterizing the monitoring relay at any time via a display unit or displaying the measured values in a control room or locally at the machine/control cabinet

Even without communication via IO-Link the devices continue to function fully autonomously:

- Parameterization can take place locally at the device, independently of a controller
- In the event of failure or before the controller becomes available the monitoring relays work as long as the control supply voltage (24 V DC) is present
- If the monitoring relays are operated without the controller, the 3RR24 monitoring relays for IO-Link have, thanks to the integrated SIO mode, an additional semiconductor output, which switches when the adjustable warning threshold is exceeded

Thanks to the combination of autonomous monitoring relay function and integrated IO-Link communication, redundant sensors and/or analog signal converters – which previously took over the transmission of measured values to a controller, leading to considerable extra cost and wiring outlay – are no longer needed.

Because the output relays are still present, the monitoring relays increase the functional reliability of the system, since only the controller can fulfill the control tasks if the current measured values are available, whereas the output relays can also be used for the disconnection of the system if limit values that cannot be reached during operation are exceeded.

For further information on the IO-Link communication system, see [Chapter 2 "Industrial Communication"](#).

Relays

SIRIUS 3RR24 Monitoring Relays for Mounting onto 3RT2 Contactors for IO-Link **NEW**

Current and active current monitoring

Benefits

- Can be mounted directly on 3RT2 contactors and 3RA23 reversing contactor assemblies, in other words, there is no need for additional wiring in the main circuit
- Optimally coordinated with the technical characteristics of the 3RT2 contactors
- No separate current transformer required
- Variably adjustable to overshoot, undershoot or range monitoring
- Freely configurable delay times and RESET response
- Display of ACTUAL value and status messages
- All versions with removable control current terminals
- All versions with screw or spring-type terminals
- Simple determination of the threshold values through direct reference to actually measured values for setpoint loading
- Range monitoring and selectable active current measurement mean that only one device for monitoring a motor is required along the entire torque curve
- In addition to current monitoring it is also possible to monitor for current unbalance, broken cables, phase failure, phase sequence, residual current and motor blocking
- Integrated counter for operating cycles and operating hours to support requirements-based maintenance of the monitored machine or application
- Simple cyclical transmission of the current measured values, relay switching states and events to a controller
- Remote parameterization
- Automatic reparameterizing when devices are exchanged
- Simple duplication of identical or similar parameterizations
- Reduction of control current wiring
- Elimination of testing costs and wiring errors
- Reduction of configuration work
- Integration in TIA means clear diagnostics if a fault occurs
- Cost saving and space saving in control cabinet due to the elimination of AI and IO modules as well as analog signal converters and duplicated sensors

Application

- Monitoring of current overshoot and undershoot
- Monitoring of broken conductors
- Monitoring of no-load operation and load shedding, e.g. in the event of a torn V-belt or no-load operation of a pump
- Monitoring of overload, e.g. on pumps due to a dirty filter system
- Monitoring the functionality of electrical loads such as heaters
- Monitoring of wrong phase sequence on mobile equipment such as compressors or cranes
- Monitoring of high-impedance faults to ground, e.g. caused by damaged insulation or moisture

The use of SIRIUS monitoring relays for IO-Link is particularly recommended for machines and plant in which these relays, in addition to their monitoring function, are to be connected to the automation level for the rapid, simple and fault-free provision of the current measured values and/or for remote parameterization.

The monitoring relays can either relieve the controller of monitoring tasks or, as a second monitoring entity in parallel to and independent of the controller, increase the reliability in the process or in the system. In addition, the elimination of AI and IO modules allows the width of the controller to be reduced despite significantly expanded functionality.

NEW SIRIUS 3RR24 Monitoring Relays for Mounting onto 3RT2 Contactors for IO-Link

Current and active current monitoring

Technical specifications

Function charts of 3RR24 for IO-Link, digitally adjustable

With the closed-circuit principle selected upon application of the control supply voltage

Current overshoot

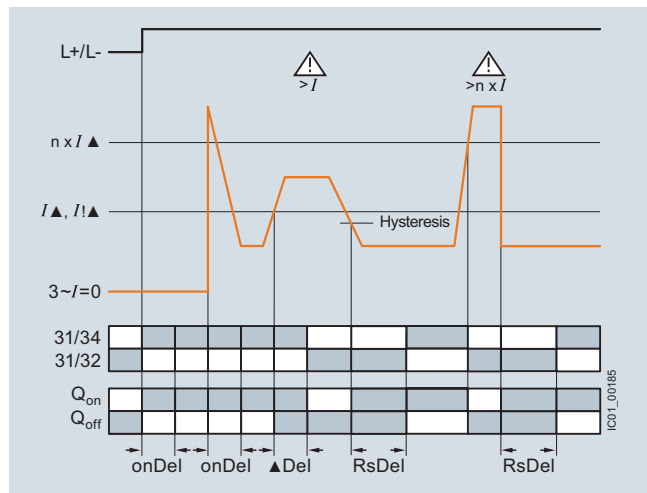

Range monitoring

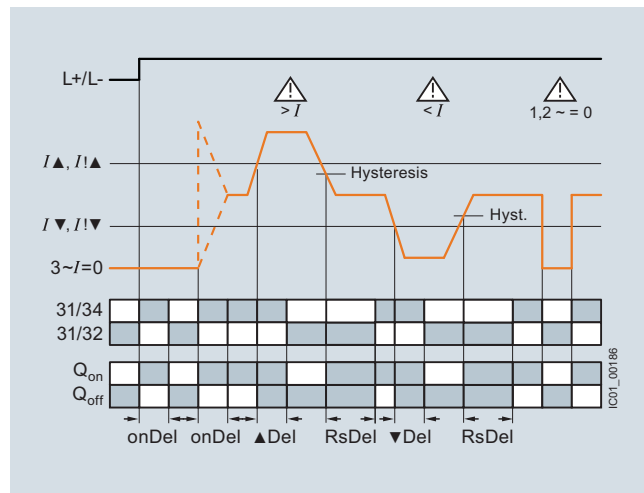

Current undershoot with residual current monitoring

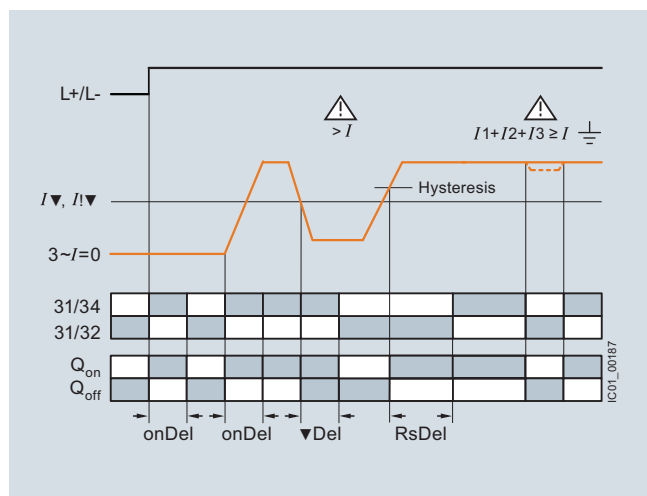

Phase sequence monitoring

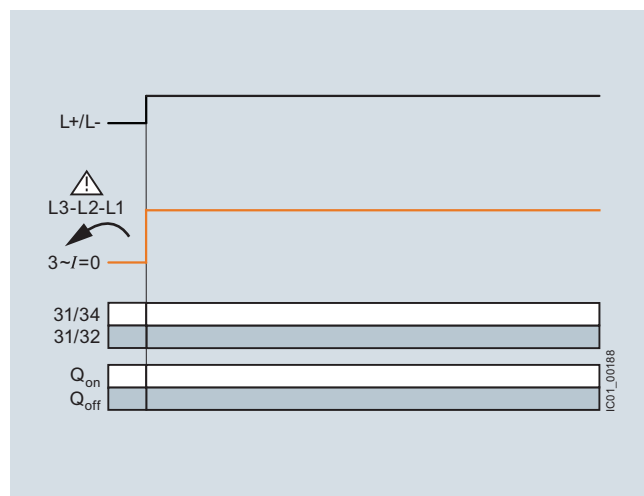

Circuit diagrams

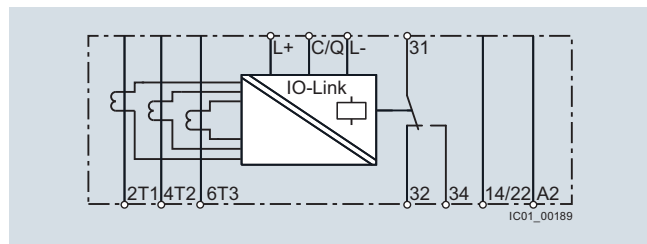

3RR2441-1AA40

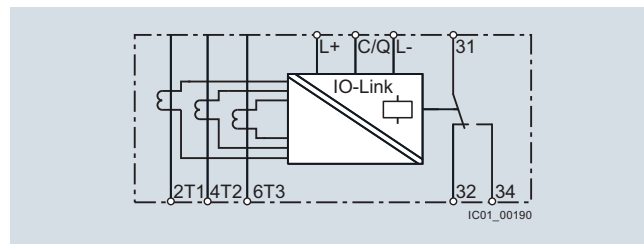

3RR2441-2AA40, 3RR2442-AA40, 3RR2443-AA40

Note:

It is not necessary to protect the measuring circuit for device protection. The protective device for line protection depends on the cross-section used.

Relays

SIRIUS 3RR24 Monitoring Relays for Mounting onto 3RT2 Contactors for IO-Link **NEW**

Current and active current monitoring

Selection and ordering data

SIRIUS 3RR24 current monitoring relays for IO-Link

- For load monitoring of motors or other loads
- Multi-phase monitoring of undercurrent and overcurrent
- Starting and tripping delay can be adjusted separately
- Tripping delay 0 to 999.9 s
- Auto or Manual RESET

PU (UNIT, SET, M) = 1
 PS* = 1 unit
 PG = 41H



3RR2441-1AA40



3RR2442-1AA40



3RR2441-2AA40





3RR2442-2AA40



3RR2443-1AA40





3RR2443-3AA40

Size	Measuring range	Hysteresis	Control supply voltage U_s	DT	Screw terminals 	DT	Spring-type terminals 	
					Article No.	Price per PU	Article No.	Price per PU
A	A	A	V					
<ul style="list-style-type: none"> • Digitally adjustable • LC display • Open or closed-circuit principle • 1 CO contact • 1 semiconductor output (in SIO mode) • 3-phase current monitoring • Active current or apparent current monitoring • Current unbalance monitoring • Phase sequence monitoring • Residual current monitoring • Blocking current monitoring • Operating hours counter • Operating cycles counter • Reclosing delay time 0 ... 300 min • Start-up delay 0 ... 999.9 s • Separate settings for warning and alarm thresholds 								
S00	1.6 ... 16	0.1 ... 3	24 DC	A	3RR2441-1AA40	A	3RR2441-2AA40	
S0	4 ... 40	0.1 ... 8	24 DC	A	3RR2442-1AA40	A	3RR2442-2AA40	
S2	8 ... 80	0.2 ... 16	24 DC	NEW A	3RR2443-1AA40	A	3RR2443-3AA40	

NEW SIRIUS 3RR24 Monitoring Relays for Mounting onto 3RT2 Contactors for IO-Link

Current and active current monitoring

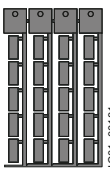
Accessories

Use	Version	Size	DT	Article No.	Price per PU	PU (UNIT, SET, M)	PS*	PG	
Terminal supports for stand-alone installation¹⁾									
 3RU2916-3AA01	For 3RR24	For separate mounting of the overload relays or monitoring relays; screw and snap-on mounting onto TH 35 standard mounting rail according to IEC 60715		Screw terminals 					
		• Screw connection	S00	▶	3RU2916-3AA01		1	1 unit	41F
			S0	▶	3RU2926-3AA01		1	1 unit	41F
		S2	NEW ▶	3RU2936-3AA01		1	1 unit	41F	
 3RU2926-3AC01	• Spring-type connection	S00	B	Spring-type terminals 					
		S0	B	3RU2916-3AC01		1	1 unit	41F	
				3RU2926-3AC01		1	1 unit	41F	
Blank labels									
 3RT2900-1SB20	For 3RR24	Unit labeling plates²⁾ For SIRIUS devices 20 mm x 7 mm, titanium gray		D	3RT2900-1SB20	100	340 units	41B	
Sealable covers									
 3RR2940	For 3RR24	Sealable covers For securing against unintentional or unauthorized adjustment of settings		A	3RR2940	1	5 units	41H	
Tools for opening spring-type terminals									
 3RA2908-1A	For auxiliary circuit connections	Screwdrivers For all SIRIUS devices with spring-type terminals; 3.0 mm x 0.5 mm; length approx. 200 mm, titanium gray/black, partially insulated		A	Spring-type terminals 				
					3RA2908-1A		1	1 unit	41B

¹⁾ The accessories are identical to those of the 3RU21 thermal overload relays and the 3RB3 electronic overload relays, see Chapter 7 "Protection Equipment".

²⁾ PC labeling system for individual inscription of unit labeling plates available from: murrplastik Systemtechnik GmbH, see Chapter 16, "Appendix" → "External Partners".

Relays

SIRIUS 3UG45, 3UG46 Monitoring Relays for Stand-Alone Installation

General data

Overview



SIRIUS 3UG4 monitoring relay

The field-proven SIRIUS monitoring relays for electrical and mechanical variables enable constant monitoring of all important characteristic quantities that provide information about the functional capability of a plant. Both sudden disturbances and gradual changes, which may indicate the need for maintenance, are detected. Thanks to their relay outputs, the monitoring relays permit direct disconnection of the affected system components as well as alerting (e.g. by switching a warning lamp). Thanks to adjustable delay times the monitoring relays can respond very flexibly to brief faults such as voltage dips or load changes. This avoids unnecessary alarms and disconnections while enhancing plant availability.

The individual 3UG4 monitoring relays offer the following functions in various combinations:

- Undershooting and/or overshooting of liquid levels
- Phase sequence
- Phase failure, neutral conductor failure
- Phase asymmetry
- Undershooting and/or overshooting of limit values for voltage
- Undershooting and/or overshooting of limit values for current
- Undershooting and/or overshooting of limit values for power factor
- Monitoring of the active current or the apparent current
- Monitoring of the residual current
- Monitoring of the insulation resistance
- Undershooting and/or overshooting of limit values for speed

Article No. scheme

Digit of the Article No.	1st - 3rd	4th	5th	6th	7th	8th	9th	10th	11th	12th
Monitoring relays	<input type="checkbox"/> <input type="checkbox"/> <input type="checkbox"/>	<input type="checkbox"/>	<input type="checkbox"/>	<input type="checkbox"/>	<input type="checkbox"/>	-	<input type="checkbox"/>	<input type="checkbox"/>	<input type="checkbox"/>	<input type="checkbox"/>
Generation	3 U G		<input type="checkbox"/>							
Type of setting			<input type="checkbox"/>							
Functions				<input type="checkbox"/>	<input type="checkbox"/>					
Connection methods							<input type="checkbox"/>			
Contacts								<input type="checkbox"/>		
Supply voltage									<input type="checkbox"/>	
Signal type of the control supply voltage										<input type="checkbox"/>
Special version										<input type="checkbox"/>
Example	3 U G	4	5	1	1	-	1	A	N	2 0

Notes:

The Article No. scheme is presented here merely for information purposes and for better understanding of the logic behind the article numbers.

For your orders, please use the article numbers quoted in the catalog in the Selection and ordering data.

Benefits

- Customary screw and spring-type terminals for quick and reliable wiring
- Fast commissioning thanks to menu-guided parameterization and actual value display for limit value determination
- Reduced space requirement in the control cabinet thanks to a consistent width of 22.5 mm
- Parameterizable monitoring functions, delay times, reset response, etc.
- Reduced stockkeeping thanks to minimized variance and large measuring ranges
- Wide-voltage power supply units for global applicability
- Device replacement without renewed wiring thanks to removable terminals
- Reliable system diagnostics thanks to actual value display and connectable fault memory
- Rapid diagnostics thanks to unambiguous error messages on the display

Advantages through energy efficiency

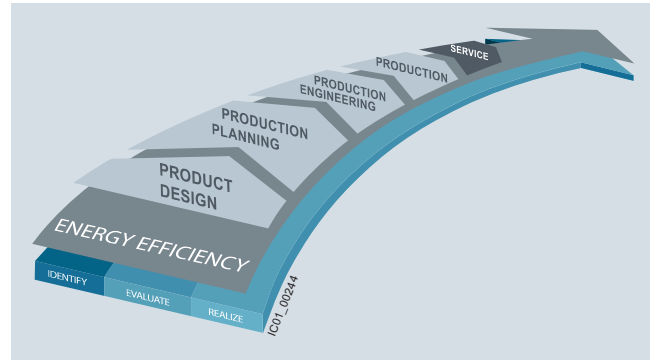

Overview of the energy management process

We offer you a unique portfolio for industrial energy management, using an energy management system that helps to optimally define your energy needs. We split up our industrial energy management into three phases – identify, evaluate, and realize – and we support you with the appropriate hardware and software solutions in every process phase.

The innovative SIRIUS industrial controls products can also make a major contribution to the energy efficiency of a plant (www.siemens.com/sirius/energysaving).

The 3UG4 monitoring relays contribute to energy efficiency throughout the plant as follows:

- Shutdown in the event of no-load operation (e.g. pump no-load operation)
- Reactive-power compensation by means of power factor monitoring
- Load shedding of predefined loads in the event of current overshoots

Application

The SIRIUS 3UG4 monitoring relays monitor the most diverse electrical and mechanical quantities in the feeder, and provide reliable protection against damage in the plant. For this purpose, they offer freely parameterizable limit values and diverse options for adapting to the respective task, and in the event of a fault, they provide clear diagnostics information.

The digitally adjustable products also display the current measured values direct on the device. This not only facilitates the display of valuable plant status information during operation, it also enables adjustment of the monitored limit values in accordance with the actual conditions.

The positive result: More selective avoidance of production faults – sustained increases in availability and productivity.

The 3UG4 monitoring relays are available for the following applications:



- Line and single-phase voltage monitoring
- Single-phase current monitoring or power factor and active current monitoring
- Residual current monitoring
- Insulation monitoring
- Level monitoring
- Speed monitoring

Relays

SIRIUS 3UG45, 3UG46 Monitoring Relays for Stand-Alone Installation

General data

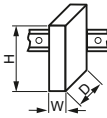
Technical specifications

Type	3UG	
General data		
Dimensions (W x H x D)		
<ul style="list-style-type: none"> For 2 terminal blocks <ul style="list-style-type: none"> - Screw terminals - Spring-type terminals For 3 terminal blocks <ul style="list-style-type: none"> - Screw terminals - Spring-type terminals For 4 terminal blocks <ul style="list-style-type: none"> - Screw terminals - Spring-type terminals 		mm 22.5 x 83 x 91 mm 22.5 x 84 x 91 mm 22.5 x 92 x 91 mm 22.5 x 94 x 91 mm 22.5 x 103 x 91 mm 22.5 x 103 x 91
Permissible ambient temperature		
<ul style="list-style-type: none"> During operation 	°C	-25 ... +60
Connection type		 Screw terminals
<ul style="list-style-type: none"> Terminal screw Solid Finely stranded with end sleeve AWG cables, solid or stranded 	mm ² mm ² AWG	M3 (for standard screwdriver, size 2 and Pozidriv 2) 1 x (0.5 ... 4)/2 x (0.5 ... 2.5) 1 x (0.5 ... 2.5)/2 x (0.5 ... 1.5) 2 x (20 ... 14)
Connection type		 Spring-type terminals
<ul style="list-style-type: none"> Solid Finely stranded, with end sleeves acc. to DIN 46228 Finely stranded AWG cables, solid or stranded 	mm ² mm ² mm ² AWG	2 x (0.25 ... 1.5) 2 x (0.25 ... 1.5) 2 x (0.25 ... 1.5) 2 x (24 ... 16)

More information

Manual "3UG45/3UG46 and 3RR21/3RR22 Monitoring Relays",
 see
<http://support.automation.siemens.com/WW/view/en/54397927>.

Overview



SIRIUS 3UG4615 monitoring relay

Solid-state line monitoring relays provide maximum protection for mobile machines and plants or for unstable networks. Network and voltage faults can thus be detected early and rectified before far greater damage ensues.

Depending on the version, the relays monitor phase sequence, phase failure with and without N conductor monitoring, phase asymmetry, undervoltage or overvoltage.

Phase asymmetry is evaluated as the difference between the greatest and the smallest phase voltage relative to the greatest phase voltage. Undervoltage or overvoltage exists when at least one phase voltage deviates by 20 % from the set rated system voltage or the directly set limit values are overshoot or undershot. The rms value of the voltage is measured.

With the 3UG4617 or 3UG4618 relay, a wrong direction of rotation can also be corrected automatically.

Benefits

- Can be used without auxiliary voltage in any network from 160 to 630 V AC worldwide thanks to wide voltage range
- Variably adjustable to overshoot, undershoot or range monitoring
- Freely configurable delay times and RESET response
- Width 22.5 mm
- Permanent display of ACTUAL value and network fault type on the digital versions
- Automatic correction of the direction of rotation by distinguishing between power system faults and wrong phase sequence
- All versions with removable terminals
- All versions with screw or spring-type terminals

Application

The relays are used above all for mobile equipment, e.g. air conditioning compressors, refrigerating containers, building site compressors and cranes.

Function	Application
Phase sequence	<ul style="list-style-type: none"> • Direction of rotation of the drive
Phase failure	<ul style="list-style-type: none"> • A fuse has tripped • Failure of the control supply voltage • Broken cable
Phase asymmetry	<ul style="list-style-type: none"> • Overheating of the motor due to asymmetrical voltage • Detection of asymmetrically loaded networks
Undervoltage	<ul style="list-style-type: none"> • Increased current on a motor with corresponding overheating • Unintentional resetting of a device • Network collapse, particularly with battery power
Overvoltage	<ul style="list-style-type: none"> • Protection of a plant against destruction due to overvoltage

Technical specifications

3UG4511 monitoring relays

The 3UG4511 phase sequenced relay monitors the phase sequence in a three-phase network. No adjustments are required for operation. The device has an internal power supply and works using the closed-circuit principle. If the phase sequence at the terminals L1-L2-L3 is correct, the output relay picks up after the delay time has elapsed and the LED is lit. If the phase sequence is wrong, the output relay remains in its rest position.

Note:

When one phase fails, connected loads (motor windings, lamps, transformers, coils, etc.) create a feedback voltage at the terminal of the failed phase due to the network coupling. Because the 3UG4511 relays are not resistant to voltage feedback, such a phase failure is not detected. Should this be required, then the 3UG4512 monitoring relay must be used.

Correct phase sequence

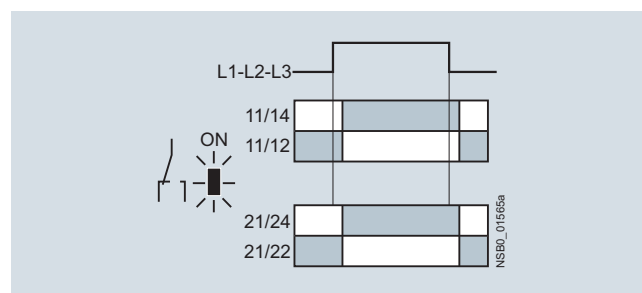

Wrong phase sequence

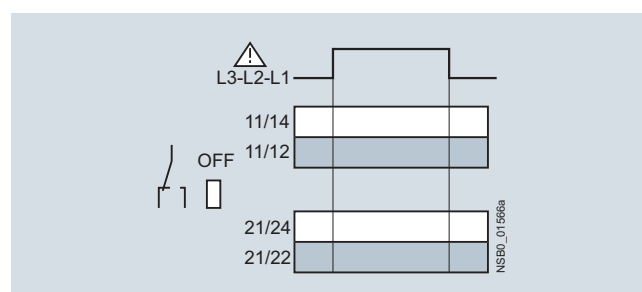

Relays

SIRIUS 3UG45, 3UG46 Monitoring Relays for Stand-Alone Installation

Line monitoring

3UG4512 monitoring relays

The 3UG4512 line monitoring relay monitors three-phase networks with regard to phase sequence, phase failure and phase unbalance of 10 %. Thanks to a special measuring method, a phase failure is reliably detected in spite of the wide voltage range from 160 to 690 V and feedback through the load of up to 90 %. The device has an internal power supply and works using the closed-circuit principle. No adjustments are required. When the mains voltage is switched on, the green LED is lit. If the phase sequence at the terminals L1-L2-L3 is correct, the output relay picks up. If the phase sequence is wrong, the red LED flashes and the output relay remains in its rest position. If a phase fails, the red LED is permanently lit and the output relay drops.

Note:

The red LED is a fault diagnostic indicator and does not show the current relay status. The 3UG4512 monitoring relay is suitable for line frequencies of 50/60 Hz.

Phase failure

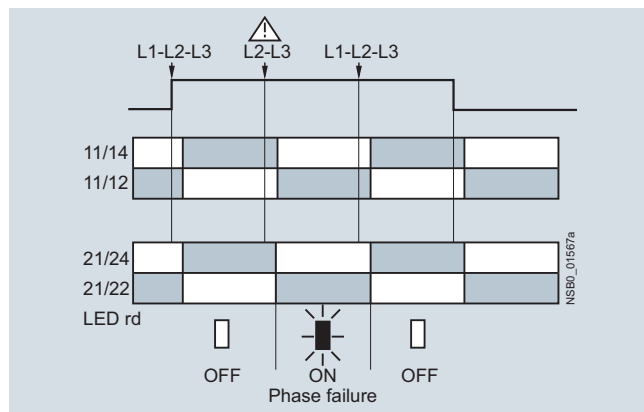

Wrong phase sequence

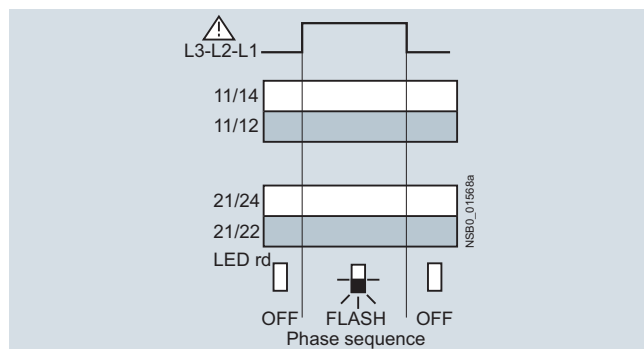

3UG4513 monitoring relays

The 3UG4513 line monitoring relay monitors three-phase networks with regard to phase sequence, phase failure, phase asymmetry and undervoltage of 20 %. The device has an internal power supply and works using the closed-circuit principle. The hysteresis is 5 %. The integrated response delay time is adjustable from 0 to 20 s and responds to undervoltage. If the direction is incorrect, the device switches off immediately. Thanks to a special measuring method, a phase failure is reliably detected in spite of the wide voltage range from 160 to 690 V and feedback through the load of up to 80 %. When the mains voltage is switched on, the green LED is lit. If the phase sequence at the terminals L1-L2-L3 is correct, the output relay picks up. If the phase sequence is wrong, the red LED flashes and the output relay remains in its rest position. If a phase fails, the red LED is permanently lit and the output relay drops.

Note:

The red LED is a fault diagnostic indicator and does not show the current relay status. The 3UG4513 monitoring relay is suitable for line frequencies of 50/60 Hz.

Phase failure and undervoltage

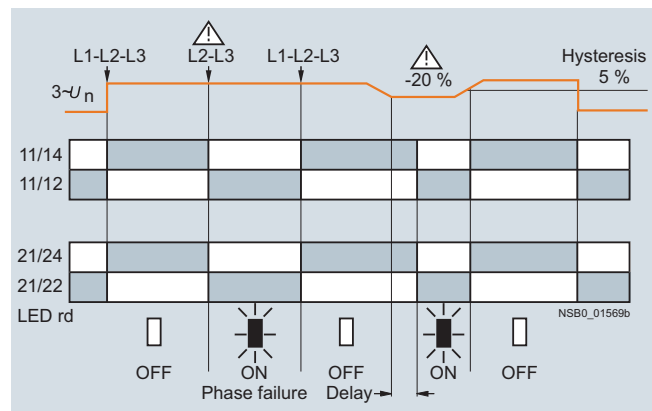

Wrong phase sequence

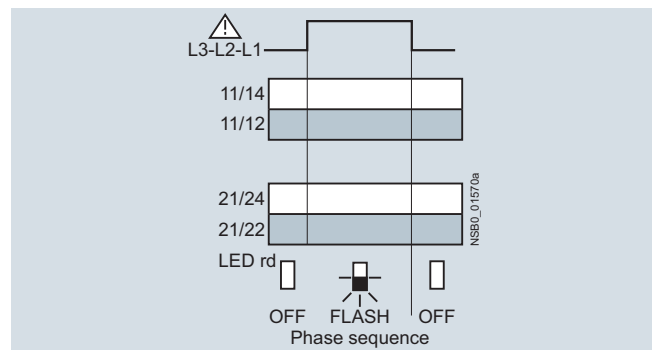

3UG4614 monitoring relays

The 3UG4614 line monitoring relay has a wide voltage range input and an internal power supply. The device is equipped with a display and is parameterized using three buttons. The unit monitors three-phase networks with regard to phase asymmetry from 5 to 20 %, phase failure, undervoltage and phase sequence. The hysteresis is adjustable from 1 to 20 V. In addition the device has a response delay and ON-delay from 0 to 20 s in each case. The integrated response delay time responds to phase asymmetry and undervoltage. If the direction is incorrect, the device switches off immediately. Thanks to a special measuring method, a phase failure is reliably detected in spite of the wide voltage range from 160 to 690 V and feedback through the load of up to 80 %.

The 3UG4614 monitoring relay can be operated on the basis of either the open-circuit or closed-circuit principle and with manual or Auto RESET.

With the closed-circuit principle selected

Wrong phase sequence

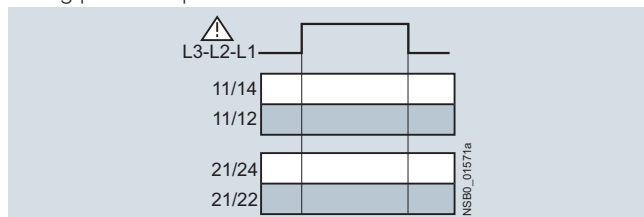

Phase failure

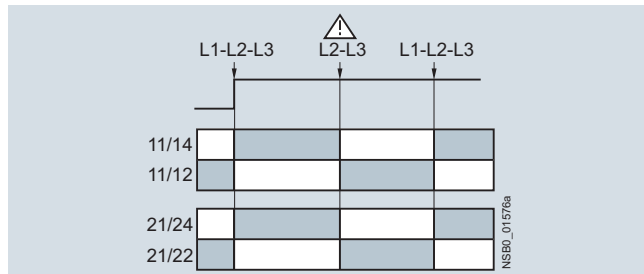

Undervoltage

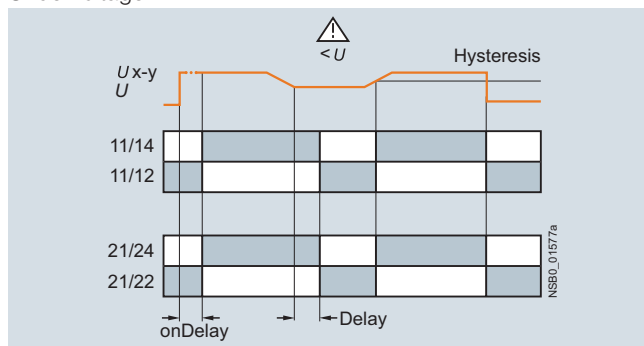

Unbalance

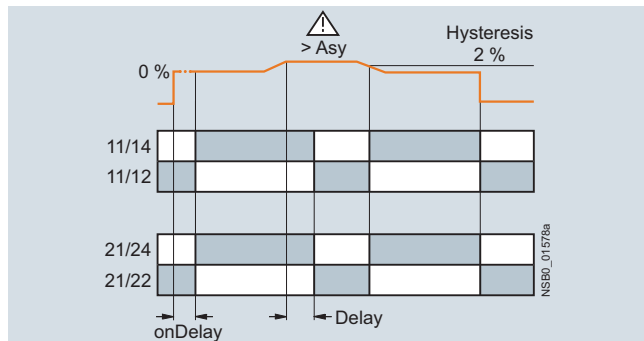

3UG4615/3UG4616 monitoring relays

The 3UG4615/3UG4616 line monitoring relay has a wide voltage range input and an internal power supply. The device is equipped with a display and is parameterized using three buttons. The 3UG4615 device monitors three-phase networks with regard to phase failure, undervoltage, overvoltage and phase sequence. The 3UG4616 monitoring relay monitors the neutral conductor as well. The hysteresis is adjustable from 1 to 20 V. In addition the device has two separately adjustable delay times for overvoltage and undervoltage from 0 to 20 s in each case. If the direction is incorrect, the device switches off immediately. Thanks to a special measuring method, a phase failure is reliably detected in spite of the wide voltage range from 160 to 690 V and feedback through the load of up to 80 %.

The 3UG4615/3UG4616 monitoring relay can be operated on the basis of either the open-circuit or closed-circuit principle and with manual or Auto RESET.

With the closed-circuit principle selected

Wrong phase sequence

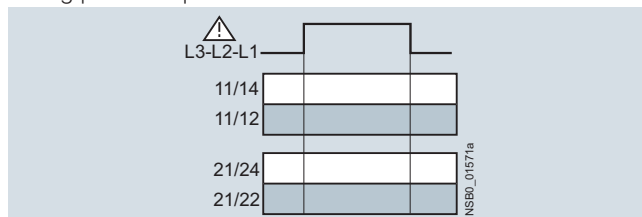

Phase failure

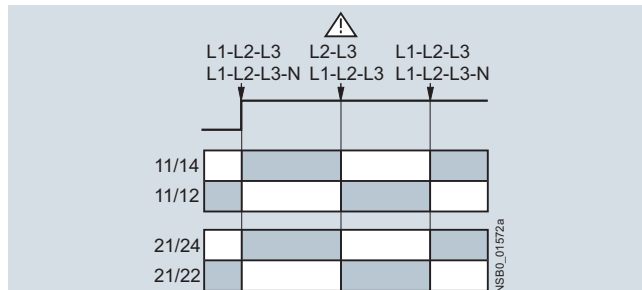

Undervoltage

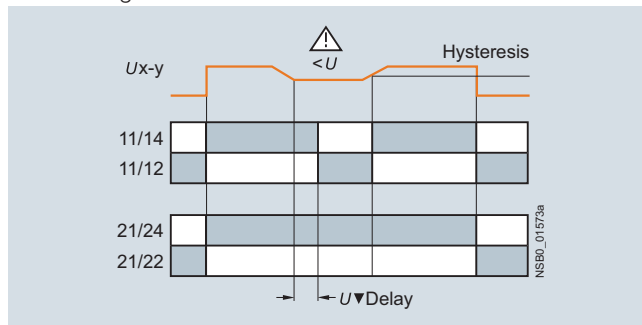

Overvoltage

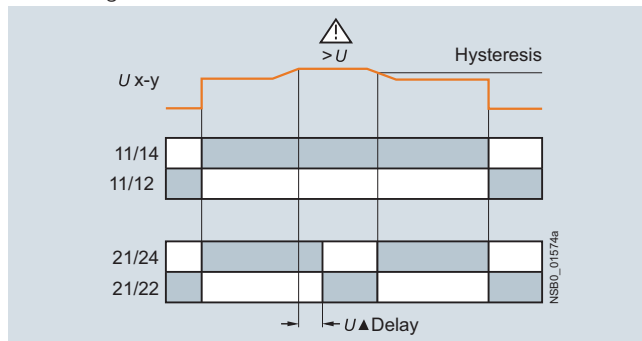

Relays

SIRIUS 3UG45, 3UG46 Monitoring Relays for Stand-Alone Installation

Line monitoring

3UG4617/3UG4618 monitoring relays

The 3UG4617/3UG4618 line monitoring relay has an internal power supply and can automatically correct a wrong direction of rotation. Thanks to a special measuring method, a phase failure is reliably detected in spite of the wide voltage range from 160 to 690 V AC and feedback through the load of up to 80 %. The device is equipped with a display and is parameterized using three buttons. The 3UG4617 line monitoring relay unit monitors three-phase networks with regard to phase sequence, phase failure, phase unbalance, undervoltage and overvoltage. The 3UG4618 monitoring relay monitors the neutral conductor as well. The hysteresis is adjustable from 1 to 20 V. In addition the device has delay times from 0 to 20 s in each case for overvoltage, undervoltage, phase failure and phase unbalance. The 3UG4617/3UG4618 monitoring relay can be operated on the basis of either the open-circuit or closed-circuit principle and with manual or Auto RESET. The one changeover contact is used for warning or disconnection in the event of power system faults (voltage, unbalance), the other responds only to a wrong phase sequence. In conjunction with a contactor reversing assembly it is thus possible to change the direction automatically.

With the closed-circuit principle selected

Phase failure

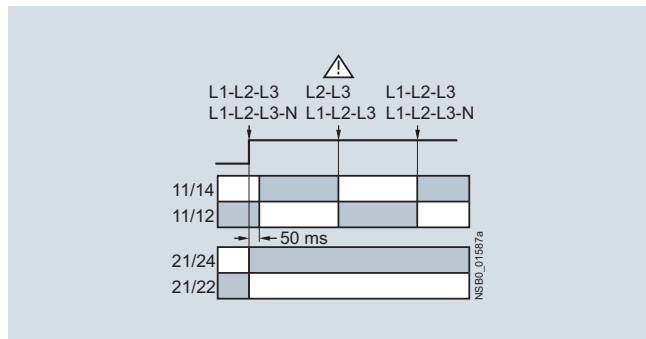

Undervoltage

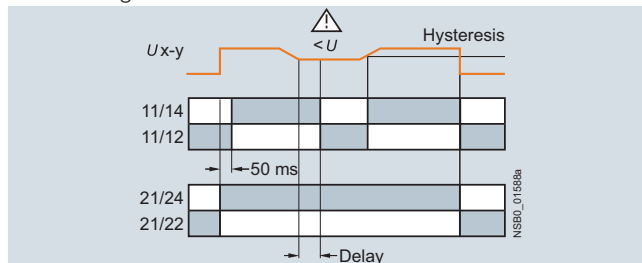

Overvoltage

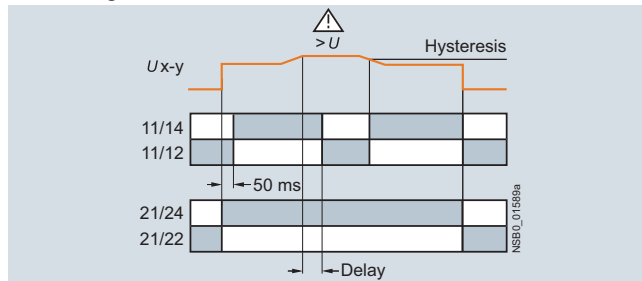

Unbalance

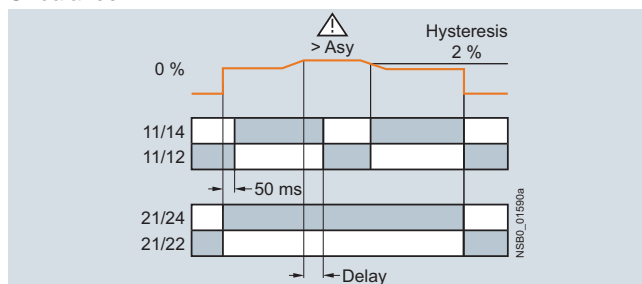

Type	3UG4511 ... 3UG4513, 3UG4614 ... 3UG4618	
General data		
Rated insulation voltage U_i	V	690
Pollution degree 3 Overvoltage category III acc. to VDE 0110		
Rated impulse withstand voltage U_{imp}	kV	6
Control circuit		
Load capacity of the output relay		
• Conventional thermal current I_{th}	A	5
Rated operational current I_e at		
• AC-15/24 ... 400 V	A	3
• DC-13/24 V	A	1
• DC-13/125 V	A	0.2
• DC-13/250 V	A	0.1
Minimum contact load at 17 V DC	mA	5
Electrical endurance AC-15	Million operating cycles	0.1
Mechanical endurance	Million operating cycles	10

Circuit diagrams

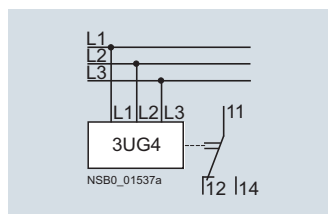

3UG4511-A,
3UG4512-A

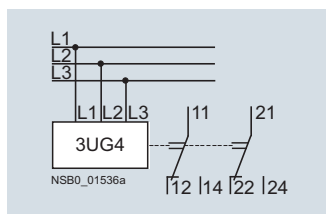

3UG4511-B, 3UG4512-B,
3UG4513, 3UG4614,
3UG4615, 3UG4617

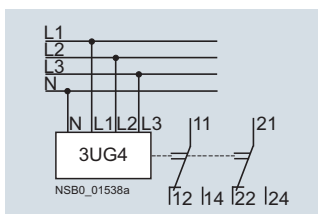

3UG4616,
3UG4618

Note:

It is not necessary to protect the measuring circuit for device protection. The protective device for line protection depends on the cross-section used.

Selection and ordering data

PU (UNIT, SET, M) = 1
 PS* = 1 unit
 PG = 41H



3UG4511-1AP20



3UG4615-1CR20



3UG4616-1CR20



3UG4617-1CR20



3UG4618-1CR20



3UG4511-2BP20



3UG4512-2BR20

Adjustable hysteresis	Under-voltage detection	Over-voltage detection	Stabilization time adjustable stDEL	Tripping delay time adjustable Del	Version of auxiliary contacts	Measurable mains voltage ¹⁾	DT	Screw terminals	DT	Spring-type terminals	
			s	s	CO contact	V		Article No.	Price per PU	Article No.	Price per PU

Monitoring of phase sequence

Auto RESET

--	--	--	--	--	1	160 ... 260 AC	A	3UG4511-1AN20	A	3UG4511-2AN20
					2		A	3UG4511-1BN20	A	3UG4511-2BN20
					1	320 ... 500 AC	A	3UG4511-1AP20	A	3UG4511-2AP20
					2		A	3UG4511-1BP20	A	3UG4511-2BP20
					1	420 ... 690 AC	A	3UG4511-1AQ20	B	3UG4511-2AQ20
					2		A	3UG4511-1BQ20	B	3UG4511-2BQ20

Monitoring of phase sequence, phase failure and phase unbalance

Auto RESET, closed-circuit principle, unbalance threshold permanently 10 %

--	--	--	--	--	1	160 ... 690 AC	A	3UG4512-1AR20	A	3UG4512-2AR20
					2		A	3UG4512-1BR20	A	3UG4512-2BR20

Monitoring of phase sequence, phase failure, unbalance and undervoltage

Analogically adjustable, Auto RESET, closed-circuit principle, unbalance and undervoltage threshold permanently 20 %

5 % of set value	✓	--	--	0.1 ... 20	2	160 ... 690 AC	A	3UG4513-1BR20	A	3UG4513-2BR20
------------------	---	----	----	------------	---	----------------	---	---------------	---	---------------

Digitally adjustable, Auto or Manual RESET, open-circuit or closed-circuit principle, unbalance threshold 0 or 5 ... 20 %

Adjustable	✓	--	0.1 ... 20	0.1 ... 20	2	160 ... 690 AC	A	3UG4614-1BR20	A	3UG4614-2BR20
------------	---	----	------------	------------	---	----------------	---	---------------	---	---------------

Monitoring of phase sequence, phase failure, overvoltage and undervoltage

Digitally adjustable, Auto RESET or Manual RESET, open-circuit or closed-circuit principle

Adjustable	✓	✓	--	0.1 ... 20 ²⁾	2 ²⁾	160 ... 690 AC	A	3UG4615-1CR20	A	3UG4615-2CR20
------------	---	---	----	--------------------------	-----------------	----------------	---	---------------	---	---------------

Monitoring of phase sequence, phase and N conductor failure, overvoltage and undervoltage

Digitally adjustable, Auto RESET or Manual RESET, open-circuit or closed-circuit principle

Adjustable	✓	✓	--	0.1 ... 20 ²⁾	2 ²⁾	90 ... 400 AC against N	A	3UG4616-1CR20	A	3UG4616-2CR20
------------	---	---	----	--------------------------	-----------------	-------------------------	---	---------------	---	---------------

Automatic direction correction in case of wrong phase sequence, phase failure, phase unbalance, overvoltage and undervoltage

Digitally adjustable, Auto or Manual RESET, open-circuit or closed-circuit principle, unbalance threshold 0 or 5 ... 20 %

Adjustable	✓	✓	--	0.1 ... 20	2 ³⁾	160 ... 690 AC	A	3UG4617-1CR20	A	3UG4617-2CR20
------------	---	---	----	------------	-----------------	----------------	---	---------------	---	---------------

Automatic correction of the direction of rotation in case of wrong phase sequence, phase and N conductor failure, phase unbalance, overvoltage and undervoltage

Digitally adjustable, Auto or Manual RESET, open-circuit or closed-circuit principle, unbalance threshold 0 or 5 ... 20 %

Adjustable	✓	✓	--	0.1 ... 20	2 ³⁾	90 ... 400 AC against N	A	3UG4618-1CR20	A	3UG4618-2CR20
------------	---	---	----	------------	-----------------	-------------------------	---	---------------	---	---------------

✓ Function available

-- Function not available

1) Absolute limit values.

2) 1 CO contact each and 1 tripping delay time each for U_{min} and U_{max} .

3) 1 CO contact each for power system fault and phase sequence correction.

For accessories, see page 10/132.

Relays

SIRIUS 3UG45, 3UG46 Monitoring Relays for Stand-Alone Installation

Voltage monitoring

Overview



SIRIUS 3UG4631 monitoring relay

The relays monitor single-phase AC voltages (rms value) and DC voltages against the set threshold value for overshoot and undershoot. The devices differ with regard to their power supply (internal or external).

Benefits

- Versions with wide voltage supply range
- Variably adjustable to overshoot, undershoot or range monitoring
- Freely configurable delay times and RESET response
- Width 22.5 mm
- Display of ACTUAL value and status messages
- All versions with removable terminals
- All versions with screw or spring-type terminals

Application

- Protection of a plant against destruction due to overvoltage
- Switch-on of a plant at a defined voltage and higher
- Protection from undervoltage due to overloaded control supply voltages, particularly with battery power
- Threshold switch for analog signals from 0.1 to 10 V

Technical specifications

3UG4631/3UG4632 monitoring relays

The 3UG4631/3UG4632 voltage monitoring relay is supplied with an auxiliary voltage of 24 V AC/DC or 24 to 240 V AC/DC and performs overshoot, undershoot or range monitoring of the voltage depending on parameterization. The device is equipped with a display and is parameterized using three buttons.

The measuring range extends from 0.1 to 60 V or 10 to 600 V AC/DC. The threshold values for overshoot or undershoot can be freely configured within this range. If one of these threshold values is reached, the output relay responds according to the set principle of operation as soon as the delay time has elapsed. This delay time U_{Del} can be set from 0.1 to 20 s. The hysteresis can be set from 0.1 to 30 V or 0.1 to 300 V. The device can be operated on the basis of either the open-circuit or closed-circuit principle and with manual or Auto RESET. One output changeover contact is available as signaling contact.

With the closed-circuit principle selected

Overvoltage

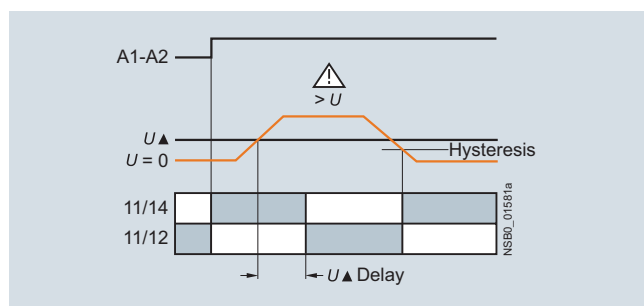

Undervoltage

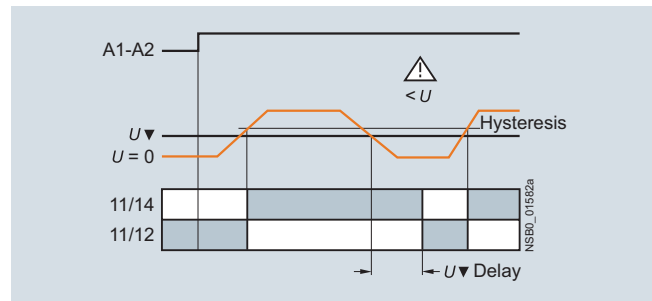

Range monitoring

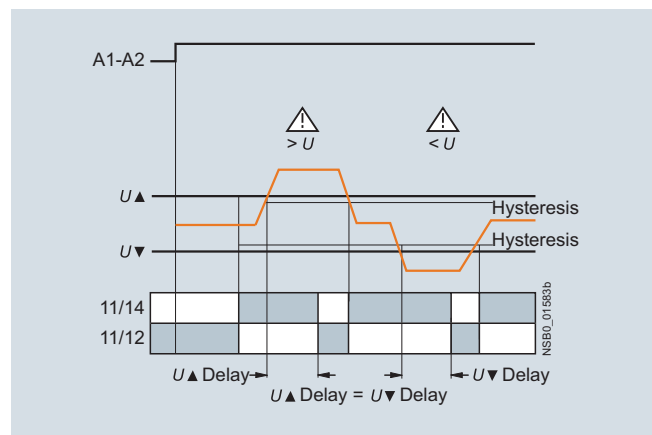

3UG4633 monitoring relays

The 3UG4633 voltage monitoring relay has an internal power supply and performs overshoot, undershoot or range monitoring of the voltage depending on parameterization. The device is equipped with a display and is parameterized using three buttons.

The operating and measuring range extends from 17 to 275 V AC/DC. The threshold values for overshoot or undershoot can be freely configured within this range. If one of these threshold values is reached, the output relay responds according to the set principle of operation as soon as the tripping delay time has elapsed. This delay time U_{Del} can be set from 0.1 to 20 s like the ON-delay time on_{Del} .

The hysteresis is adjustable from 0.1 to 150 V. The device can be operated on the basis of either the open-circuit or closed-circuit principle and with manual or Auto RESET. One output change-over contact is available as signaling contact.

With the closed-circuit principle selected

Overvoltage

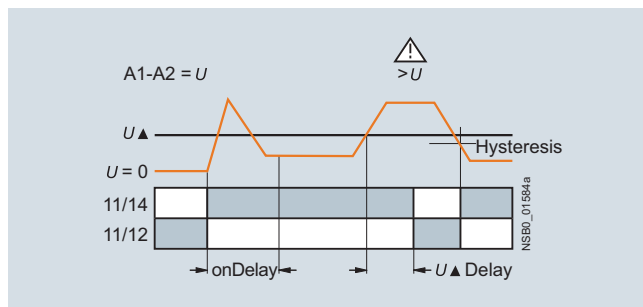

Undervoltage

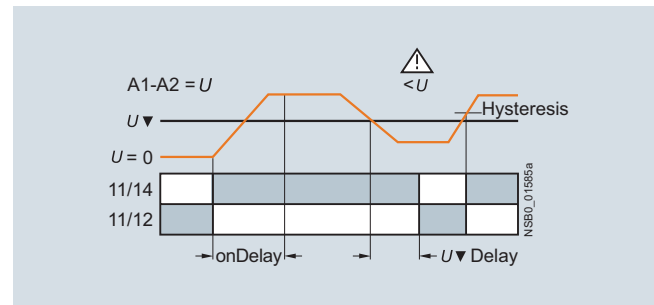

Range monitoring

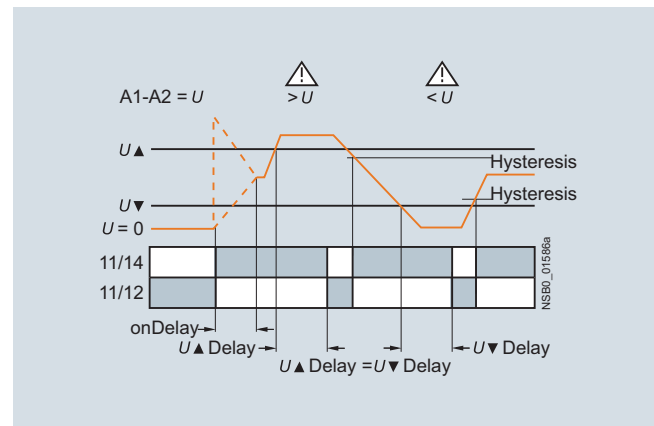

Type		3UG4631	3UG4632	3UG4633
General data				
Rated insulation voltage U_i	V	690		
Pollution degree 3 Overvoltage category III according to VDE 0110				
Rated impulse withstand voltage U_{imp}	kV	6		
Measuring circuit				
Permissible measuring range single-phase AC/DC voltage	V	0.1 ... 68	10 ... 650	17 ... 275
Setting range single-phase voltage	V	0.1 ... 60	10 ... 600	17 ... 275
Measuring frequency	Hz	40 ... 500		
Control circuit				
Load capacity of the output relay				
• Conventional thermal current I_{th}	A	5		
Rated operational current I_o at				
• AC-15/24 ... 400 V	A	3		
• DC-13/24 V	A	1		
• DC-13/125 V	A	0.2		
• DC-13/250 V	A	0.1		
Minimum contact load at 17 V DC	mA	5		

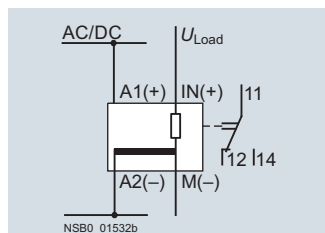
Circuit diagrams

3UG4631-AA30,
3UG4632-AA30

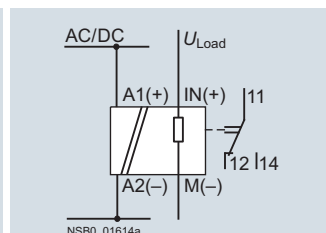

3UG4631-AW30,
3UG4632-AW30

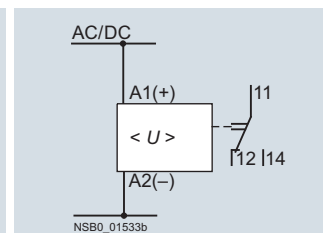

3UG4633

Note:

It is not necessary to protect the measuring circuit for device protection. The protective device for line protection used.

Relays

SIRIUS 3UG45, 3UG46 Monitoring Relays for Stand-Alone Installation

Voltage monitoring

Selection and ordering data

- Digitally adjustable, with illuminated LCD
- Auto or Manual RESET
- Open or closed-circuit principle
- 1 CO contact



PU (UNIT, SET, M) = 1
 PS* = 1 unit
 PG = 41H



3UG4631-1AA30



3UG4633-2AL30

Measuring range	Adjustable hysteresis	Rated control supply voltage U_s	DT	Screw terminals 	DT	Spring-type terminals 	
V	V	V		Article No.	Price per PU	Article No.	Price per PU
Internal power supply without auxiliary voltage, ON-delay and tripping delay times can be adjusted separately 0.1 ... 20 s							
17 ... 275 AC/DC	0.1 ... 150	17 ... 275 AC/DC ¹⁾	A	3UG4633-1AL30	A	3UG4633-2AL30	
Supplied from an external auxiliary voltage, tripping delay time adjustable 0.1 ... 20 s							
0.1 ... 60 AC/DC 10 ... 600 AC/DC	0.1 ... 30 0.1 ... 300	24 AC/DC	A A	3UG4631-1AA30 3UG4632-1AA30	A A	3UG4631-2AA30 3UG4632-2AA30	
0.1 ... 60 AC/DC 10 ... 600 AC/DC	0.1 ... 30 0.1 ... 300	24 ... 240 AC/DC	A A	3UG4631-1AW30 3UG4632-1AW30	A A	3UG4631-2AW30 3UG4632-2AW30	

¹⁾ Absolute limit values.

For accessories, see page 10/132.

Overview



SIRIUS 3UG4622 monitoring relay

The relays monitor single-phase AC currents (rms value) and DC currents against the set threshold value for overshoot and undershoot. They differ with regard to their measuring ranges and control supply voltage types.

Benefits

- Versions with wide voltage supply range
- Variably adjustable to overshoot, undershoot or range monitoring
- Freely configurable delay times and RESET response
- Width 22.5 mm
- Display of ACTUAL value and status messages
- All versions with removable terminals
- All versions with screw or spring-type terminals

Application

- Overcurrent and undercurrent monitoring
- Monitoring the functionality of electrical loads
- Open-circuit monitoring
- Threshold switch for analog signals from 4 to 20 mA

Technical specifications

3UG4621/3UG4622 monitoring relays

The 3UG4621 or 3UG4622 current monitoring relay is supplied with an auxiliary voltage of 24 V AC/DC or 24 to 240 V AC/DC and performs overshoot, undershoot or range monitoring of the current depending on parameterization. The device is equipped with a display and is parameterized using three buttons.

The measuring range extends from 3 to 500 mA or 0.05 to 10 A. The rms value of the current is measured. The threshold values for overshoot or undershoot can be freely configured within this range. If one of these threshold values is reached, the output relay responds according to the set principle of operation as soon as the tripping delay time I_{Del} has elapsed. This time and the ON-delay time on_{Del} are adjustable from 0.1 to 20 s.

The hysteresis is adjustable from 0.1 to 250 mA or 0.01 to 5 A. The device can be operated with manual or Auto RESET and on the basis of either the open-circuit or closed-circuit principle. Following options are available: Response of the output relay when the control supply voltage $U_s = ON$ is applied or not until the lower measuring range limit of the measuring current ($I > 3 \text{ mA}/50 \text{ mA}$) is reached. One output changeover contact is available as signaling contact.

With the closed-circuit principle selected upon application of the control supply voltage

Current overshoot

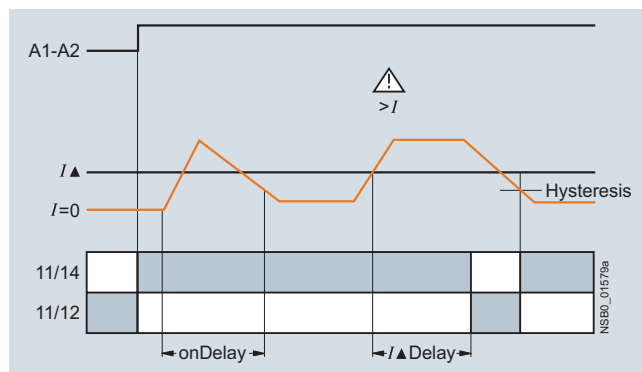

Current undershoot

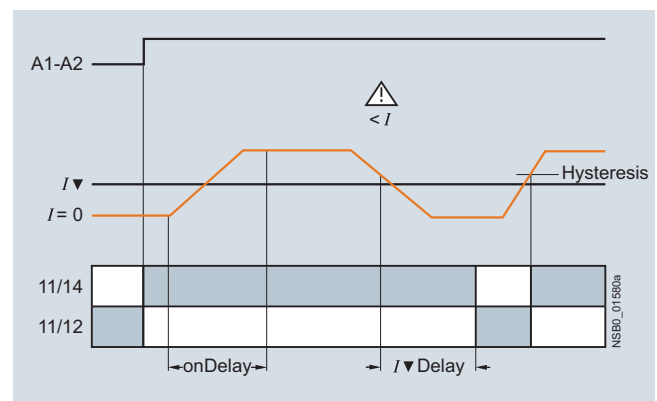

Range monitoring

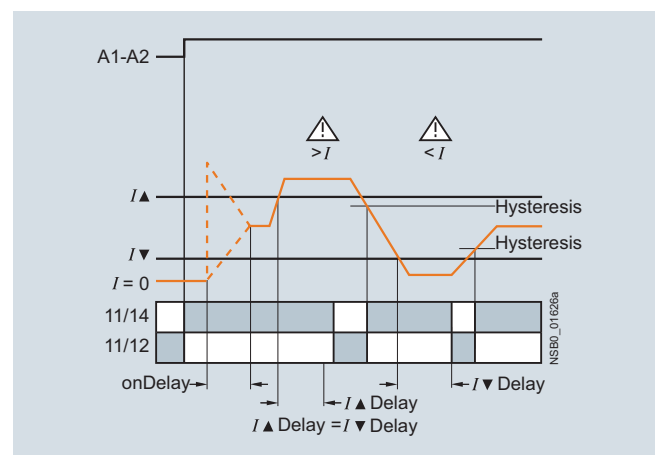

Relays

SIRIUS 3UG45, 3UG46 Monitoring Relays for Stand-Alone Installation

Current monitoring

Type	3UG4621-.AA	3UG4621-.AW	3UG4622-.AA	3UG4622-.AW
General data				
Rated insulation voltage U_i Pollution degree 3; overvoltage category III according to VDE 0110	V	690		
Rated impulse withstand voltage U_{imp}	kV	6		
Measuring circuit				
Measuring range single-phase AC/DC current	A	0.003 ... 0.6	0.05 ... 15	
Setting range for single-phase current	A	0.003 ... 0.5	0.05 ... 10	
Load supply voltage	V	24	Max. 300 ¹⁾ Max. 500 ²⁾	24
Control circuit				
Load capacity of the output relay • Conventional thermal current I_{th}	A	5		
Rated operational current I_e at				
• AC-15/24 ... 400 V	A	3		
• DC-13/24 V	A	1		
• DC-13/125 V	A	0.2		
• DC-13/250 V	A	0.1		
Minimum contact load at 17 V DC	mA	5		

1) With protective separation.

2) With simple separation.

Circuit diagrams

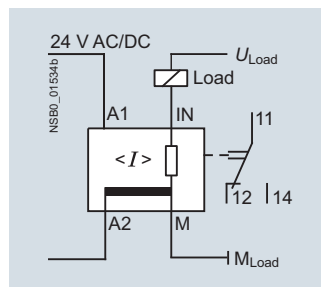

3UG4621-.AA30,
3UG4622-.AA30

Operation with separate
control circuit and load circuit

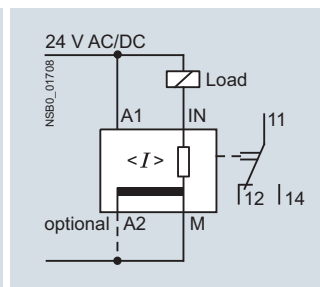

3UG4621-.AA30,
3UG4622-.AA30

Operation with joint
control circuit and load circuit

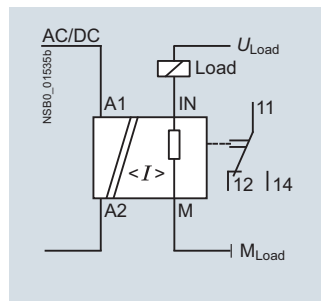

3UG4621-.AW30,
3UG4622-.AW30

Single-phase operation

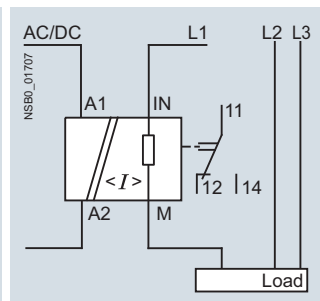

3UG4621-.AW30,
3UG4622-.AW30

Three-phase operation

Connection diagrams for 24 V AC/DC (only 3UG462-.AA30)

From the following circuit diagrams it is clear that loads in measuring circuits have to be in the current flow upstream from the monitoring relay. Otherwise, the monitoring relay could be destroyed and the short-circuit current could cause damage to the plant.

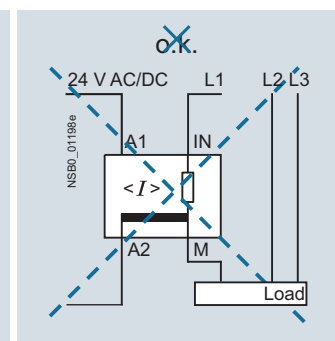
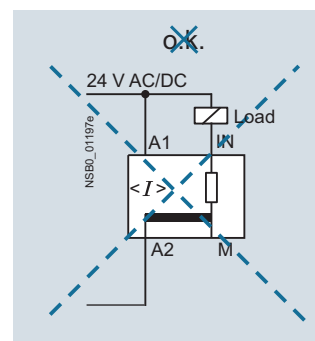
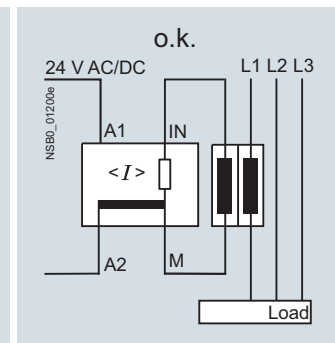
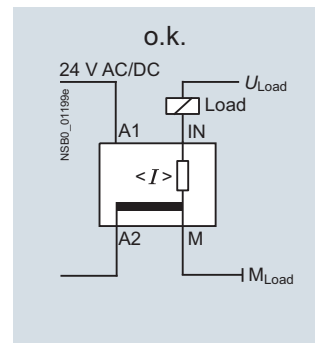

Configuring note:

A2 and M are electrically connected internally.

For applications in which the load to be monitored and the monitoring relay are supplied from the same power supply, there is no need for connection A2.

The load current must always flow through M or the monitoring relay may be destroyed.

Selection and ordering data

- Digitally adjustable, with illuminated LCD
- Auto or Manual RESET
- Open or closed-circuit principle
- 1 CO contact



PU (UNIT, SET, M) = 1
 PS* = 1 unit
 PG = 41H



3UG4621-1AA30



3UG4622-2AW30

Measuring range	Adjustable hysteresis	Rated control supply voltage U_s	DT	Screw terminals 		Spring-type terminals 	
				Article No.	Price per PU	Article No.	Price per PU
				V			
Monitoring of undercurrent and overcurrent, start up delay and tripping delay times can be adjusted separately 0.1 ... 20 s							
3 ... 500 mA AC/DC	0.1 ... 250 mA	24 AC/DC ¹⁾	A	3UG4621-1AA30	A	3UG4621-2AA30	
0.05 ... 10 A AC/DC	0.01 ... 5 A		A	3UG4622-1AA30	A	3UG4622-2AA30	
3 ... 500 mA AC/DC	0.1 ... 250 mA	24 ... 240 AC/DC ²⁾	A	3UG4621-1AW30	A	3UG4621-2AW30	
0.05 ... 10 A AC/DC	0.01 ... 5 A		A	3UG4622-1AW30	A	3UG4622-2AW30	

¹⁾ No electrical separation. Load supply voltage 24 V.

²⁾ Electrical separation between control circuit and measuring circuit. Load supply voltage for protective separation max. 300 V, for simple isolation max. 500 V.

For accessories, [see page 10/132](#).

With AC currents $I > 10$ A it is possible to use 4NC current transformers as an accessory, [see Catalog LV 10 "Low-Voltage Power Distribution and Electrical Installation Technology"](#).

Relays

SIRIUS 3UG45, 3UG46 Monitoring Relays for Stand-Alone Installation

Power factor and active current monitoring

Overview



SIRIUS 3UG4641 monitoring relay

The 3UG4641 power factor and active current monitoring device enables the load monitoring of motors.

Whereas power factor monitoring is used above all for monitoring no-load operation, the active current monitoring option can be used to observe and evaluate the load factor over the entire torque range.

Benefits

- Can be used worldwide thanks to wide voltage range from 90 to 690 V (absolute limit values)
- Monitoring of even small single-phase motors with a no-load supply current below 0.5 A
- Simple determination of threshold values by the direct collection of measured variables on motor loading
- Range monitoring and active current measurement enable detection of cable breaks between control cabinets and motors, as well as phase failures
- Power factor or I_{res} (active current) can be selected as measurement principle
- Width 22.5 mm
- All versions with removable terminals

Application

- No-load monitoring and load shedding, such as in the event of a V-belt tear
- Underload monitoring in the low performance range, e.g. in the event of pump no-load operation
- Monitoring of overload, e.g. due to a dirty filter system
- Simple power factor monitoring in power systems for control of compensation equipment
- Broken cable between control cabinet and motor

Technical specifications

3UG4641 monitoring relays

The 3UG4641 monitoring relay is self-powered and serves the single-phase monitoring of the power factor or performs overshoot, undershoot or range monitoring of the active current depending on how it is parameterized. The load to be monitored is connected upstream of the IN terminal. The load current flows through the terminals IN and Ly/N. The setting range for the power factor is 0.1 to 0.99 and for the active current I_{res} 0.2 to 10 A. If the control supply voltage is switched on and no load current flows, the display will show $I < 0.2$ and a symbol for overrange, underrange or range monitoring. If the motor is now switched on and the current exceeds 0.2 A, the set ON-delay time begins. During this time, if the set limit values are undershot or exceeded, this does not lead to a relay reaction of the changeover contact. If the operational flowing active current and/or the power factor value falls below or exceeds the respective set threshold value, the spike delay begins. When this time has expired, the relay changes its switch position. The relevant measured variables for overshooting and undershooting in the display flash. If the monitoring of active current undershooting is deactivated ($I_{res} \nabla = \text{OFF}$) and the load current drops below the lower measuring range threshold (0.2 A), then the CO contacts remain unchanged. If a threshold value is set for the monitoring of active current undershooting, then undershooting of the measuring range threshold (0.2 A) will result in a response of the CO contacts.

The relay operates either according to the open-circuit or closed-circuit principle. If the device is set to Auto RESET (Memory = No), depending on the set principle of operation, the switching relay returns to its initial state and the flashing ends when the hysteresis threshold is reached.

If Manual RESET is selected in the menu (Memory = Yes), the switching relay remains in its current switching state and the current measured value and the symbol for undershooting and overshooting continues to flash, even when the measured variable reaches a permissible value again. This stored fault status can be reset by pressing the UP▲ or DOWN▼ key simultaneously for 2 seconds, or by switching the supply voltage off and back on again.

With the closed-circuit principle selected

Response in the event of undershooting the measuring range limit

- With activated monitoring of $I_{res} \nabla$

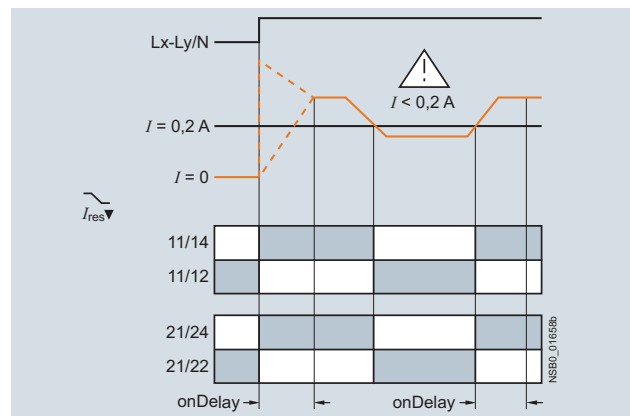

- With deactivated monitoring of active current undershooting

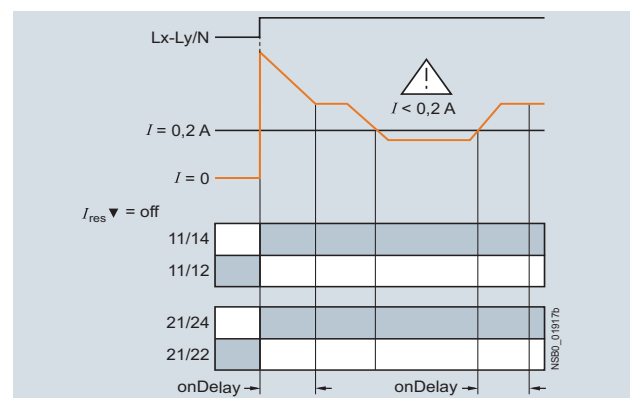

Overshooting of active current

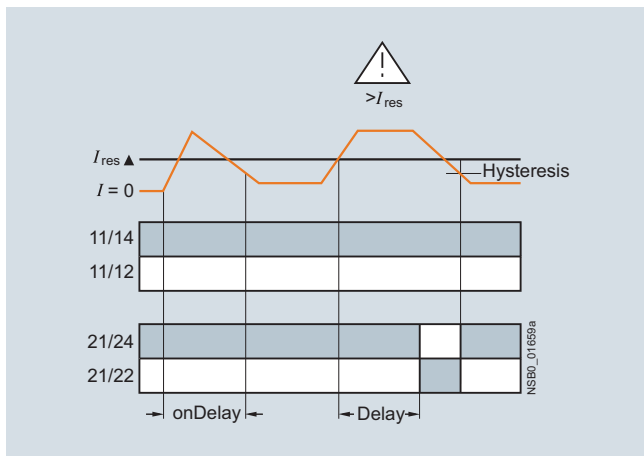

Overshooting of power factor

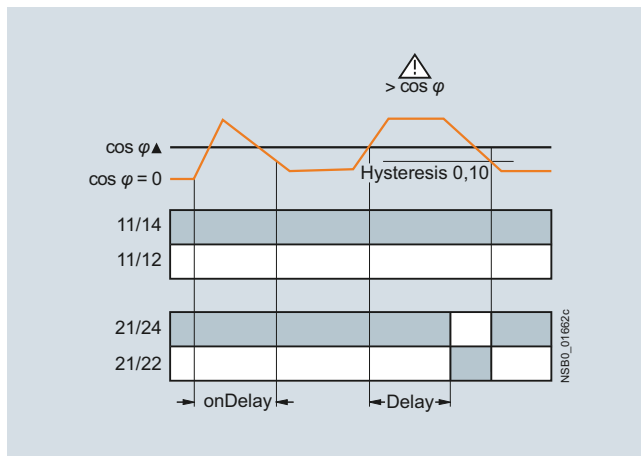

Undershooting of active current

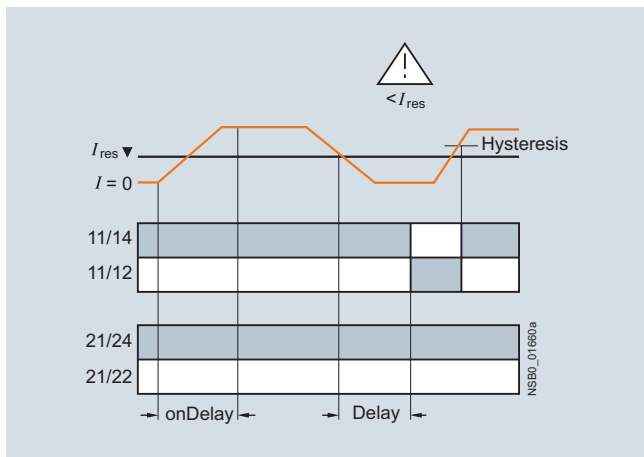

Undershooting of power factor

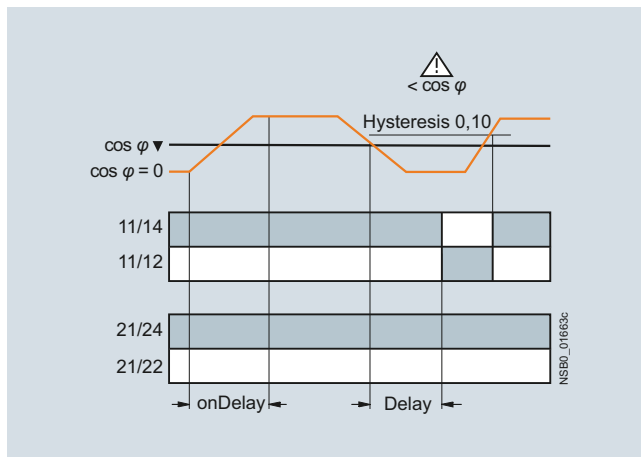

Range monitoring of active current

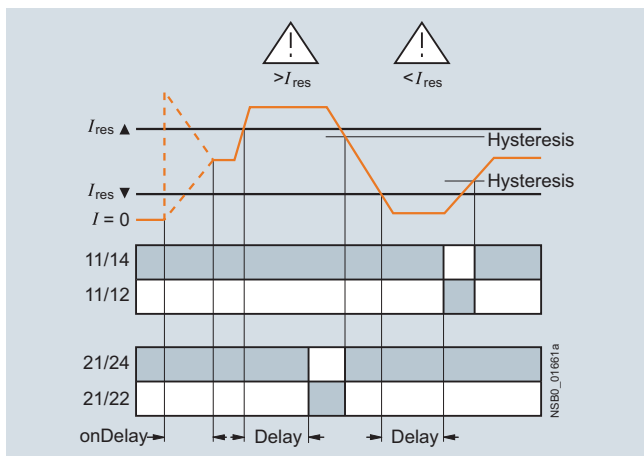

Range monitoring of power factor

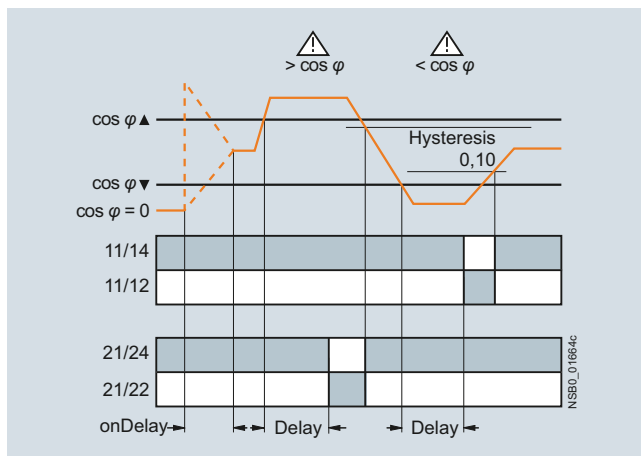

Relays

SIRIUS 3UG45, 3UG46 Monitoring Relays for Stand-Alone Installation

Power factor and active current monitoring

Type	3UG4641	
General data		
Rated insulation voltage U_i	V	690
Pollution degree 3 Overvoltage category III acc. to VDE 0110		
Rated impulse withstand voltage U_{imp}	kV	6
Control circuit		
Number of CO contacts for auxiliary contacts		2
Load capacity of the output relay		
• Conventional thermal current I_{th}	A	5
Rated operational current I_e at		
• AC-15/24 ... 400 V	A	3
• DC-13/24 V	A	1
• DC-13/125 V	A	0.2
• DC-13/250 V	A	0.1
Minimum contact load at 17 V DC	mA	5

Circuit diagrams

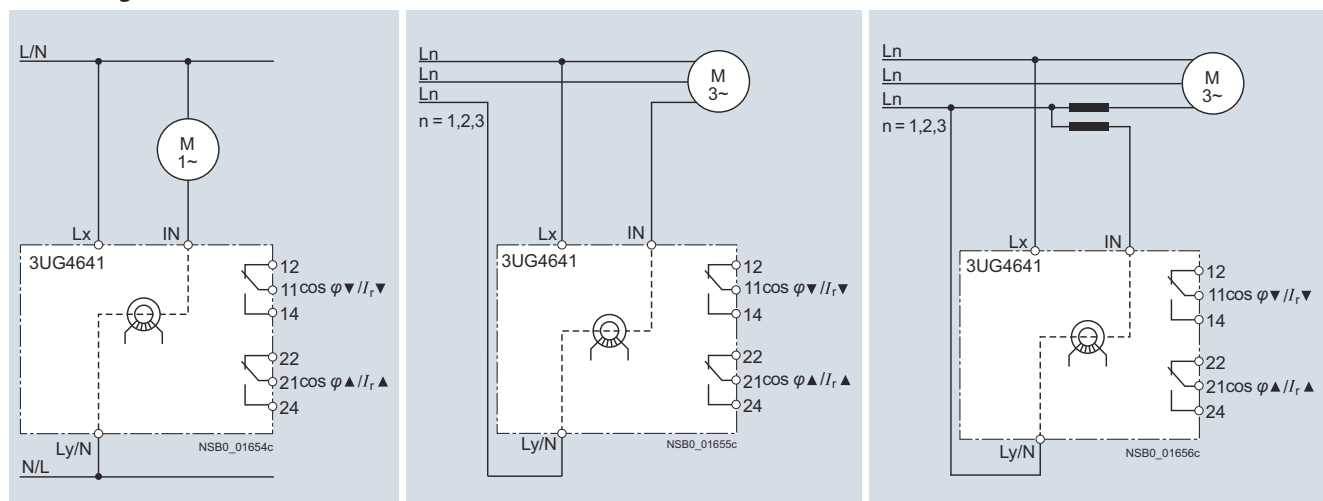

Single-phase motors

Three-phase motors

Three-phase motors with transformers for currents > 10 A

10

Selection and ordering data

- For monitoring the power factor and the active current I_{res} (p.f. $\times I$)
- Suitable for single- and three-phase currents
- Digitally adjustable, with illuminated LCD
- Overshoot, undershoot or range monitoring adjustable
- Upper and lower threshold value can be adjusted separately
- Permanent display of actual value and tripping state
- 1 changeover contact each for undershoot/overshoot

PU (UNIT, SET, M) = 1
PS* = 1 unit
PG = 41H

Measuring range		Adjustable hysteresis		ON-delay time adjustable onDel	Tripping delay time adjustable $I_{\Delta Del}/I_{\nabla Del}, \varphi_{\Delta Del}/\varphi_{\nabla Del}$	Rated control supply voltage U_s 1) 50/60 Hz AC	DT	Screw terminals		DT	Spring-type terminals	
For power factor	For active current I_{res}	For power factor	For active current I_{res}					Article No.	Price per PU		Article No.	Price per PU
P.f.	A	P.f.	A	s	s	V	A	3UG4641-1CS20	A	3UG4641-2CS20		
0.10 ... 0.99	0.2 ... 10.0	0.1	0.1 ... 2.0	0 ... 99	0.1 ... 20.0	90 ... 690						

1) Absolute limit values.

For accessories, see page 10/132.

With AC active currents $I_{res} > 10$ A it is possible to use 4NC current transformers as an accessory, see Catalog LV 10 "Low-Voltage Power Distribution and Electrical Installation Technology".

SIRIUS 3UG45, 3UG46 Monitoring Relays for Stand-Alone Installation

NEW Residual Current Monitoring

Residual-current monitoring relays

Overview



SIRIUS 3UG4625 monitoring relay

The 3UG4625 residual-current monitoring relays are used in conjunction with the 3UL23 residual-current transformers for monitoring plants in which higher residual currents are increasingly expected due to ambient conditions. Monitoring encompasses pure AC residual currents or AC residual currents with a pulsating DC fault current component (transformer type A in accordance with DIN VDE 0100-530/IEC TR 60755).

Benefits

- Worldwide use thanks to wide voltage range from 24 to 240 V AC/DC
- High measuring accuracy $\pm 7.5\%$
- Permanent self-monitoring
- Variable threshold values for warning and disconnection
- Freely configurable delay times and RESET response
- Permanent display of the actual value and fault diagnostics via the display
- High level of flexibility and space saving through installation of the transformer inside or outside the control cabinet
- Width 22.5 mm
- All versions with removable terminals
- All versions with screw or spring-type terminals

Application

Monitoring of plants in which residual currents can occur, e.g. due to dust deposits or moisture, porous cables and leads, or capacitive residual currents.

Technical specifications

3UG4625 monitoring relays

The main conductor, and any neutral conductor to which a load is connected, are routed through the opening of the annular ring core of a residual-current transformer. A secondary winding is placed around this annular strip-wound core to which the monitoring relay is connected.

If operation of a plant is fault-free, the sum of the inflowing and outward currents equals zero. No current is then induced in the secondary winding of the residual-current transformer.

However, if an insulation fault occurs downstream of the residual current operated circuit breaker, the sum of the inflowing currents is greater than that of the outward currents. The differential current – the residual current – induces a secondary current in the secondary winding of the transformer. This current is evaluated in the monitoring relay and is used on the one hand to display the actual residual current and on the other, to switch the relay if the set warning or tripping threshold is overshoot.

If the measured residual current exceeds the set warning value, the associated changeover contact instantly changes the switching state and an indication appears on the display.

If the measured residual current exceeds the set tripping value, the set delay time begins and the associated relay symbol flashes. On expiry of this time, the associated changeover contact changes the switching state.

ON-delay time for motor start

To be able to start a drive when a residual current is detected, the output relays switch to the OK state for an adjustable ON-delay time depending on the selected open-circuit principle or closed-circuit principle.

The changeover contacts do not react if the set threshold values are overshoot during this period.

With the closed-circuit principle selected

Residual current monitoring with Auto RESET (Memory = no)

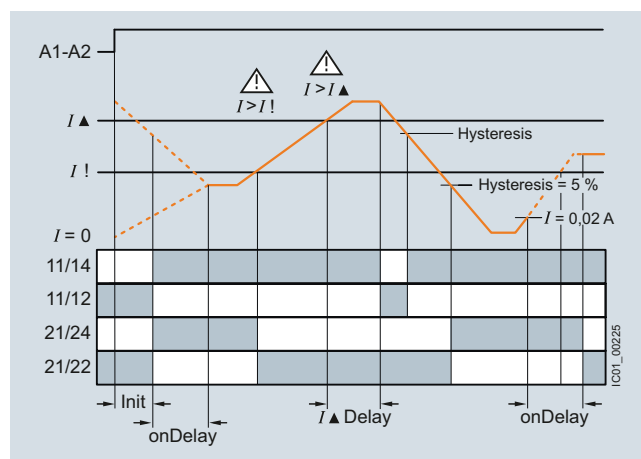

If the device is set to Auto RESET, the relay switches back to the OK state for the tripping value once the value falls below the set hysteresis threshold and the display stops flashing.

The associated relay changes its switching state if the value falls below the fixed hysteresis value of 5% of the set warning value.

Any overshoots are therefore not stored.

Relays

SIRIUS 3UG45, 3UG46 Monitoring Relays for Stand-Alone Installation Residual Current Monitoring **NEW**

Residual-current monitoring relays

Residual current monitoring with Manual RESET (Memory = yes)

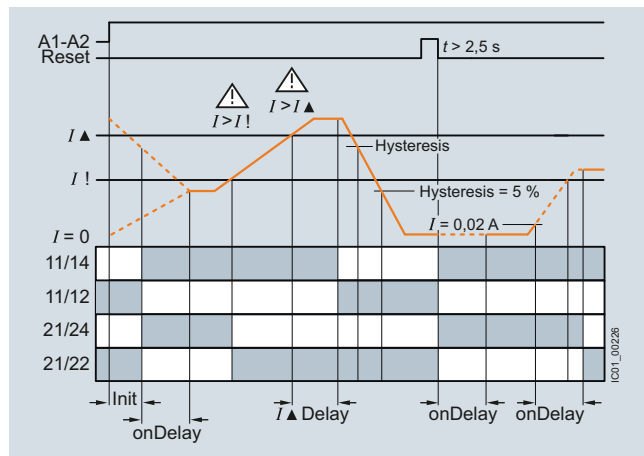

If Manual RESET is selected in the menu, the output relays remain in their current switching state and the current measured value and the symbol for overshooting continues to flash, even when the measured residual current returns to a permissible value. This stored fault status can be reset by pressing the UP▲ or DOWN▼ key simultaneously for > 2 seconds, or by switching the supply voltage off and back on again.

Note:

Do not ground the neutral conductor downstream of the residual-current transformer as otherwise residual current monitoring functions can no longer be ensured.

Type	3UG4625-1CW30, 3UG4625-2CW30	
General data		
Insulation voltage for overvoltage category III to IEC 60664 for pollution degree 3 rated value	V	300
Impulse withstand voltage rated value U_{imp}	kV	4
Control circuit		
Number of CO contacts for auxiliary contacts		2
Thermal current of the non-solid-state contact blocks maximum	A	5
Current carrying capacity of the output relay		
• At AC-15 at 250 V at 50/60 Hz	A	3
• At DC-13		
- At 24 V	A	1
- At 125 V	A	0.2
- At 250 V	A	0.1
Operational current at 17 V minimum	mA	5

Circuit diagram

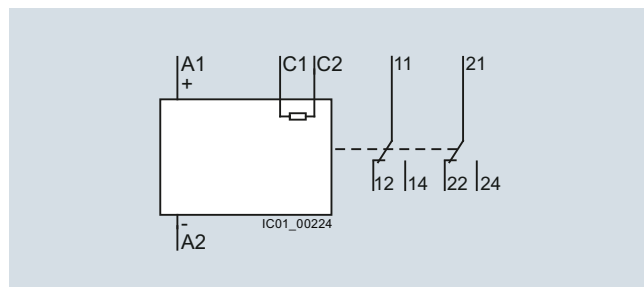

3UG4625

Note:

It is not necessary to protect the measuring circuit for device protection. The protective device for line protection depends on the cross-section used.

SIRIUS 3UG45, 3UG46 Monitoring Relays for Stand-Alone Installation
NEW Residual Current Monitoring

Residual-current monitoring relays

Selection and ordering data

- For monitoring residual currents from 0.03 to 40 A, from 16 to 400 Hz
- For 3UL23 residual-current transformers with feed-through opening from 35 to 210 mm
- Permanent self-monitoring
- Certified in accordance with IEC 60947, functionality corresponds to IEC 62020
- Digitally adjustable, with illuminated LCD
- Permanent display of actual value and tripping state
- Separately adjustable limit value and warning threshold
- 1 changeover contact each for warning threshold and tripping threshold



PU (UNIT, SET, M) = 1
 PS* = 1 unit
 PG = 41H



3UG4625-1CW30



3UG4625-2CW30

Measur-able current	Adjustable response value current	Switching hysteresis	Adjustable ON-delay time	Control supply voltage			DT	Screw terminals 		DT	Spring-type terminals 	
				For AC at 50 Hz rated value	For AC at 60 Hz rated value	At DC rated value		Article No.	Price per PU		Article No.	Price per PU
A	A	%	s	V	V	V	A	3UG4625-1CW30	A	3UG4625-2CW30		

For accessories, see page 10/132.

3UL23 residual-current transformers, see page 10/114.

Relays

SIRIUS 3UG45, 3UG46 Monitoring Relays for Stand-Alone Installation Residual Current Monitoring **NEW**

3UL23 residual-current transformers

Overview



SIRIUS 3UL23 residual-current transformer

The 3UL23 residual-current transformers detect residual currents in machines and plants. They are suitable for pure AC residual currents or AC residual currents with a pulsating DC fault current component (transformer type A in accordance with DIN VDE 0100-530/IEC TR 60755).

Together with the 3UG4625, 3UG4825 residual-current monitoring relays for IO-Link or the SIMOCODE 3UF motor management and control device they enable residual-current and ground-fault monitoring.

The 3UL2302-1A and 3UL2303-1A residual-current transformers with a feed-through opening from 35 to 55 mm can be mounted in conjunction with the 3UL2900 accessories on a TH 35 standard mounting rail according to IEC 60715.

Technical specifications

Dimensional drawing

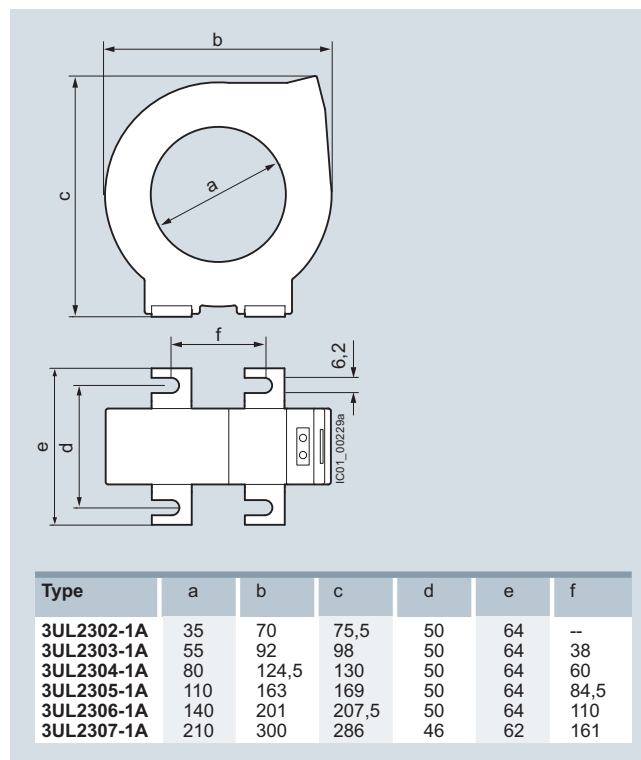

Selection and ordering data

Diameter of the bushing opening	Connectable cross-section of the connecting terminal	DT	Screw terminals	PU (UNIT, SET, M)	PS*	PG
mm	mm ²		Article No.	Price per PU		
Residual-current transformer (essential accessory for 3UG4625, 3UG4825 or SIMOCODE 3UF)						
35	2.5	A	3UL2302-1A	1	1 unit	41H
55	2.5	A	3UL2303-1A	1	1 unit	41H
80	2.5	A	3UL2304-1A	1	1 unit	41H
110	2.5	A	3UL2305-1A	1	1 unit	41H
140	2.5	A	3UL2306-1A	1	1 unit	41H
210	4	A	3UL2307-1A	1	1 unit	41H

Accessories

Version	DT	Article No.	Price per PU	PU (UNIT, SET, M)	PS*	PG
Adapters						
	A	3UL2900		1	2 units	41H
Adapters		For mounting onto standard rail for 3UL23 to diameter 55 mm				
3UL2900						

Overview



SIRIUS 3UG458. insulation monitor

Insulation monitoring relays are used for monitoring the insulation resistance between ungrounded single or three-phase AC supplies and a protective conductor.

Ungrounded, i.e. isolated networks (IT networks) are always used where high demands are placed on the reliability of the power supply, e.g. emergency lighting systems. IT systems are supplied via an isolating transformer or by power supply sources such as batteries or a generator. While an initial insulation fault between a phase conductor and the ground effectively grounds the conductor, as a result no circuit has been closed, so it is possible to continue work in safety (single-fault safety).

However, the fault must be rectified as quickly as possible before a second insulation fault occurs (e.g. according to DIN VDE 0100-410). For this purpose insulation monitoring relays are used, which constantly measure the resistance to ground of the phase conductor and the neutral conductor, reporting a fault immediately if insulation resistance falls below the set value so that either a controlled shutdown can be performed or the fault can be rectified without interrupting the power supply.

Two device series

- 3UG4581 insulation monitoring relays for ungrounded AC networks
- 3UG4582 and 3UG4583 insulation monitoring relays for ungrounded DC and AC networks

Benefits

- Devices for AC and DC systems
- All devices have a wide control supply voltage range
- Direct connection to networks with mains voltages of up to 690 V AC and 1 000 V DC by means of a voltage reducer module
- For AC supply systems: Frequency range 15 to 400 Hz
- Monitoring of broken conductors
- Monitoring of setting errors
- Safety in use thanks to integrated system test after startup
- Option of resetting and testing (by means of button on front or using control contact)
- New predictive measurement principle allows very fast response times

Application

IT networks are used for example:

- In emergency power supplies
- In safety lighting systems
- In industrial production facilities with high availability requirements (chemical industry, automobile manufacturing, printing plants)
- In shipping and railways
- For mobile generators (aircraft)
- For renewable energies, such as wind energy and photovoltaic power plants
- In the mining industry

Relays

SIRIUS 3UG45, 3UG46 Monitoring Relays for Stand-Alone Installation Insulation Monitoring

General data

Technical specifications

Type	3UG4581-1AW30	3UG4582-1AW30	3UG4583-1CW30
General data			
Setting range for the setpoint response values • 1 ... 100 kΩ • 2 ... 200 kΩ	✓ --	✓ --	✓ ✓
Rated voltage of the network being monitored • 0 ... 250 V AC • 0 ... 440 V AC • 0 ... 690 V AC • 0 ... 300 V DC • 0 ... 600 V DC • 0 ... 1 000 V DC	-- ✓ -- -- -- --	✓ -- -- ✓ -- --	-- ✓ ✓ ¹⁾ -- ✓ ✓ ¹⁾
Max. leakage capacitance of the system • 10 μF • 20 μF	✓ --	✓ --	-- ✓
Output contacts • 1 CO • 2 CO or 1 CO + 1 CO, adjustable	✓ --	✓ --	-- ✓
Number of limit values • 1 • 1 or 2, adjustable	✓ --	✓ --	-- ✓
Principle of operation	Closed-circuit principle	Closed-circuit principle	Open-circuit/ closed-circuit principle, adjustable
Rated control supply voltage • 24 ... 240 V AC/DC	✓	✓	✓
Rated frequency • 15 ... 400 Hz • 50/60 Hz	-- ✓	✓ --	✓ --
Auto or Manual RESET	✓ Adjustable	✓ Adjustable	✓ Adjustable
Remote RESET	✓ Via control input	✓ Via control input	✓ Via control input
Non-volatile error memory	--	--	✓ Adjustable
Broken wire detection	--	--	✓ Adjustable
Replacement for			
Rated control supply voltage U_s	Voltage range of the network being monitored		
3UG3081-1AK20 110 ... 130/220 ... 240 V AC/DC	3 x 230/400 V AC		
3UG3081-1AW30 24 ... 240 V AC/DC	3 x 230/400 V AC		
3UG3082-1AW30 24 ... 240 V AC/DC	24 ... 240 V DC		

✓ Available

-- Not available

1) With voltage reducer module.

SIRIUS 3UG45, 3UG46 Monitoring Relays for Stand-Alone Installation Insulation Monitoring

For ungrounded AC networks

Overview



SIRIUS 3UG4581 insulation monitor

The 3UG4581 insulation monitoring relays are used to monitor insulation resistance according to IEC 61557-8 in ungrounded AC networks with rated voltages of up to 400 V.

These devices can monitor control circuits (single-phase) and main circuits (three-phase).

They measure insulation resistances between system cables and system ground. If the value falls below the threshold value, the output relays are switched to fault status.

In the case of 3UG4581 a higher-level DC measuring signal is used. The higher-level DC measuring signal and the resulting current are used to determine the value of the insulation resistance of the network which is to be measured.

Technical specifications

3UG4581 monitoring relays

With the closed-circuit principle selected

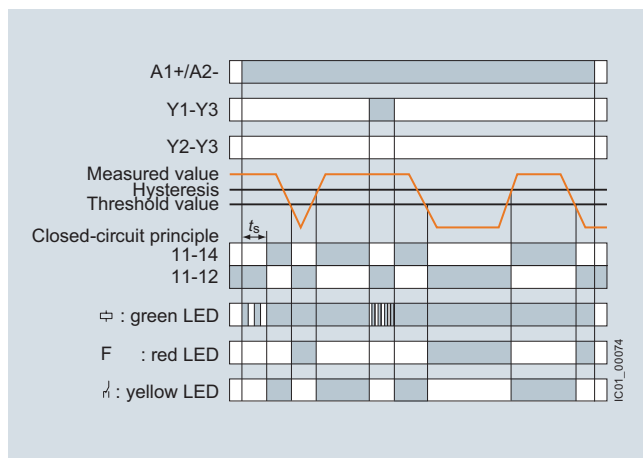

Insulation resistance monitoring without fault storage, with Auto RESET

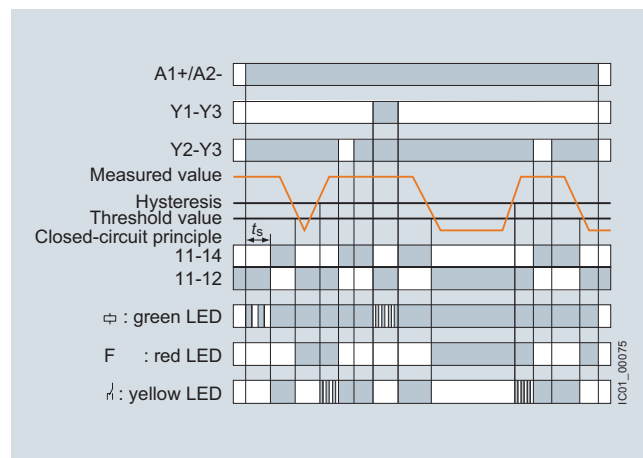

Insulation resistance monitoring with fault storage and Manual RESET

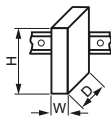

Relays**SIRIUS 3UG45, 3UG46 Monitoring Relays for Stand-Alone Installation
Insulation Monitoring****For ungrounded AC networks**

Type	3UG4581	
Dimensions (W x H x D)	mm	22.5 x 100 x 100
		
Connection type	 Screw terminals	
<ul style="list-style-type: none"> • Solid • Finely stranded with end sleeve • AWG cables, solid or stranded 	mm ² mm ² AWG	2 x (0.5 ... 4) 2 x (0.75 ... 2.5) 2 x (20 ... 14)
General data		
Rated insulation voltage U_i Pollution degree 3 Overvoltage category III acc. to IEC 60664	V	400 supply circuit/measuring circuit 300 supply circuit/output circuit
Rated impulse withstand voltage U_{imp}	kV	6
Rated control supply voltage	V	24 ... 240 AC/DC
Rated frequency	Hz	15 ... 400
Measuring circuit		
Rated mains voltage of the network being monitored	V	0 ... 400
Rated frequency of the network being monitored	Hz	50 ... 60
Setting range for insulation resistance	k Ω	1 ... 100
Control circuit		
Load capacity of the output relay • Conventional thermal current I_{th}	A	4
Rated operational current I_o at • AC-15/24 ... 400 V • DC-13/24 V	A	3 2
Minimum contact load at 24 V DC	mA	10

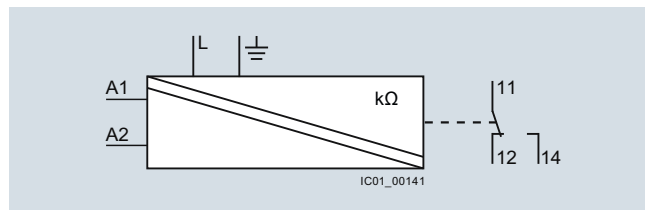
Circuit diagram

3UG4581

Note:

It is not necessary to protect the measuring circuit for device protection. The protective device for line protection depends on the cross-section used.

Connection diagrams for networks up to 400 V AC

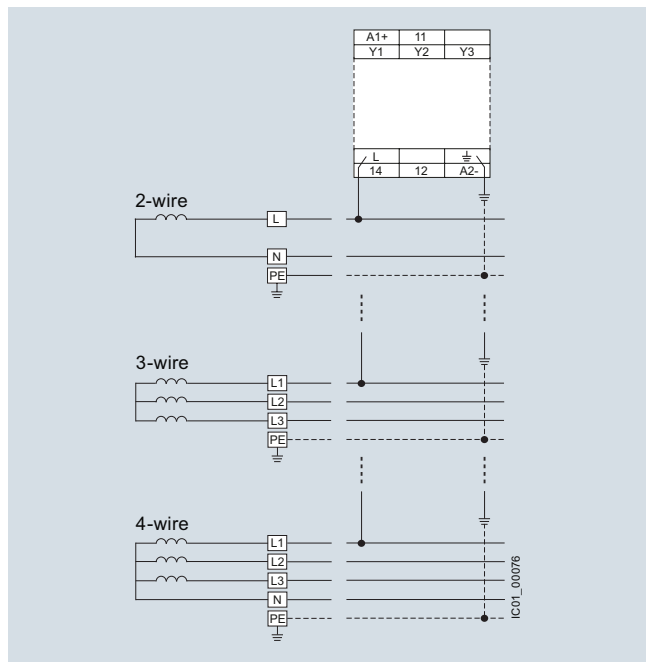

Selection and ordering data

- Auto or Manual RESET
- Closed-circuit principle
- 1 CO contact
- Fault memory adjustable using control input (Y2-Y3)
- Reset by means of button on front or using control input (Y2-Y3)
- Test by means of button on front or using control input (Y1-Y3)

Rated mains voltage U_n	Measuring range U_e	Rated control supply voltage U_s	System leakage capacitance	DT	Screw terminals	PU (UNIT, SET, M)	PS*	PG
V AC	kΩ	V	μF		Article No.	Price per PU		

Insulation monitors for ungrounded AC networks

0 ... 400	1 ... 100	24 ... 240 AC/DC	Max. 10	B	3UG4581-1AW30		1	1 unit	41H
-----------	-----------	------------------	---------	---	----------------------	--	---	--------	-----



3UG4581-1AW30

For accessories, see page 10/132.

Relays

SIRIUS 3UG45, 3UG46 Monitoring Relays for Stand-Alone Installation Insulation Monitoring

For ungrounded DC and AC networks

Overview



SIRIUS 3UG4582 and 3UG4583 insulation monitors

The 3UG4582 and 3UG4583 insulation monitoring relays are used to monitor insulation resistance in ungrounded IT AC or DC networks according to IEC 61557-8.

They measure insulation resistances between system cables and system ground. If the value falls below the threshold value, the output relays are switched to fault status. With these devices, which are suitable for both AC and DC networks, a pulsed test signal is fed into the network to be monitored and the isolation resistance is determined.

The pulsed test signal changes its form according to insulation resistance and network loss capacitance. The changed form is used to predict the changed insulation resistance.

If the predicted insulation resistance matches the insulation resistance calculated in the next measurement cycle, and is lower than the threshold value, the output relays are activated or deactivated, depending on the device configuration. This measurement principle is also suitable for identifying symmetrical insulation faults.

3UG4983 voltage reducer module

The 3UG4983 passive voltage reducer module can be used to allow the 3UG4583 insulation monitoring relay to be used for insulation monitoring of IT networks with rated voltages of up to 690 V AC and 1 000 V DC.

Technical specifications

3UG4582 monitoring relays

With the closed-circuit principle selected

Insulation resistance monitoring without fault storage, with Auto RESET

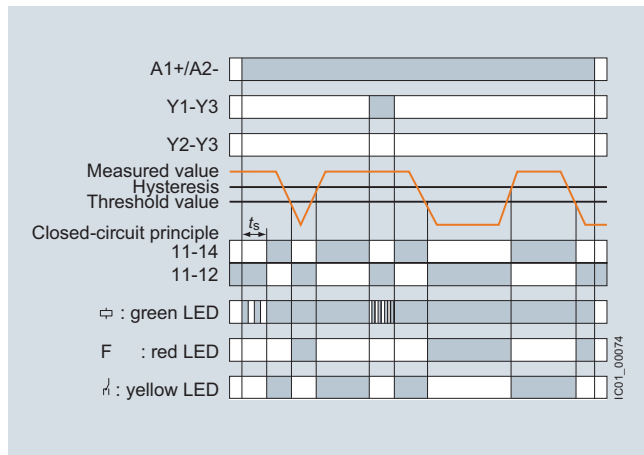

Insulation resistance monitoring with fault storage and Manual RESET

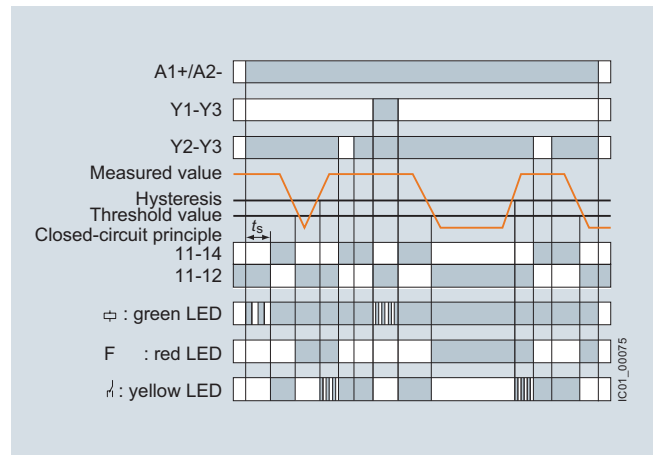

Relays

SIRIUS 3UG45, 3UG46 Monitoring Relays for Stand-Alone Installation Insulation Monitoring

For ungrounded DC and AC networks

3UG4583 monitoring relays

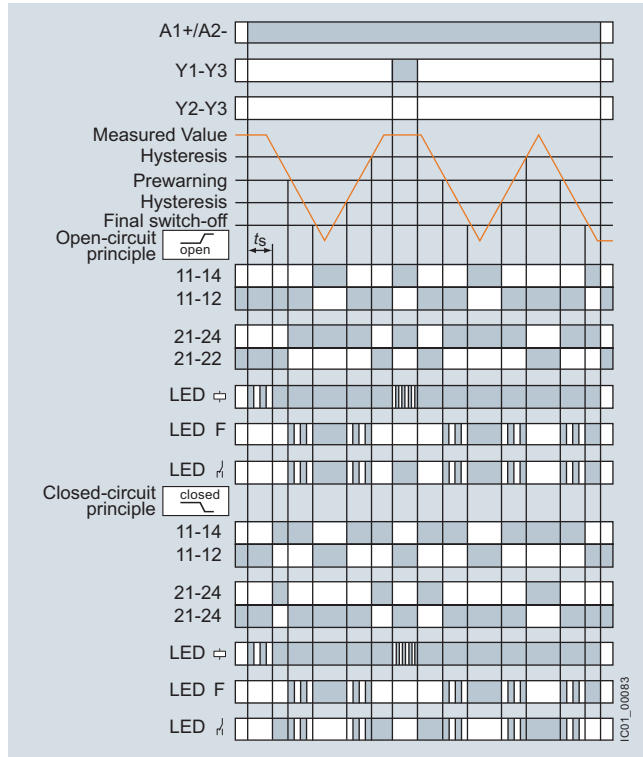

With the closed-circuit principle selected

Insulation resistance monitoring without fault storage,
with Auto RESET

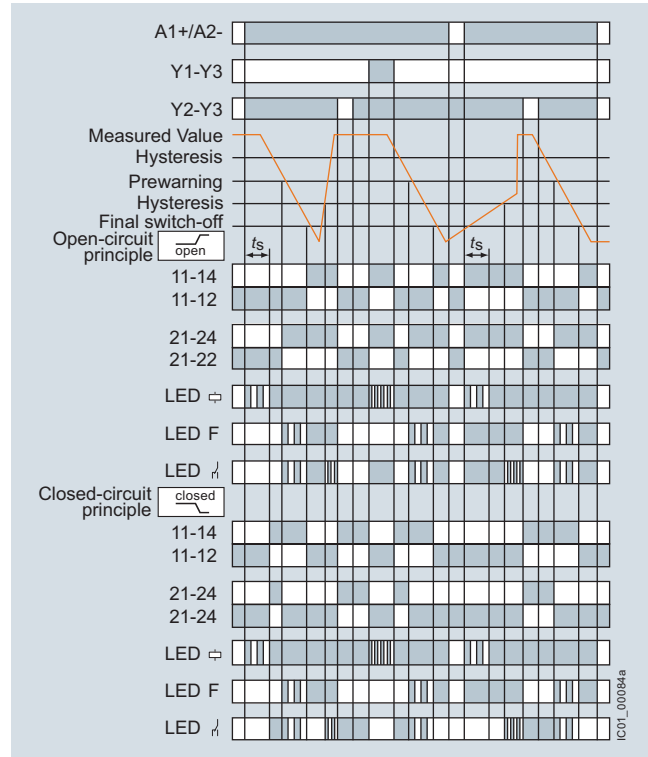

Insulation resistance monitoring with fault storage and
Manual RESET

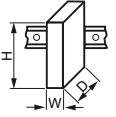

Type		3UG4582	3UG4583
Dimensions (W x H x D)	 mm	22.5 x 100 x 100	45 x 100 x 100
Connection type		 Screw terminals	
		2 x (0.5 ... 4) 2 x (0.75 ... 2.5) 2 x (20 ... 14)	
General data			
Rated insulation voltage U_i	V	400 supply circuit/measuring circuit, 300 supply circuit/output circuit	400 supply circuit/measuring circuit, 300 supply circuit/output circuit, 300 output circuit 1/output circuit 2
Pollution degree 3 Overvoltage category III acc. to IEC 60664			
Rated impulse withstand voltage U_{imp}	kV	6	
Rated control supply voltage	V AC/DC	24 ... 240	
Rated frequency	Hz	15 ... 400	
Measuring circuit			
Rated mains voltage of the network being monitored	V	0 ... 250 AC, 0 ... 300 DC	0 ... 300 AC, 0 ... 690 AC with 3UG4983 0 ... 600 DC, 0 ... 1 000 DC with 3UG4983
Rated frequency of the network being monitored	Hz	DC or 15 ... 400	
Setting range for insulation resistance	k Ω	1 ... 100	1 ... 100 2 ... 200 for 2nd limit value (disconnectable)
Control circuit			
Number of CO contacts for auxiliary contacts		1	2 or 1 + 1, adjustable
Load capacity of the output relay			
• Conventional thermal current I_{th}	A	4	
Rated operational current I_e at			
• AC-15/24 ... 400 V	A	3	
• DC-13/24 V	A	2	
Minimum contact load at 24 V DC	mA	10	

Relays

SIRIUS 3UG45, 3UG46 Monitoring Relays for Stand-Alone Installation

Insulation Monitoring

For ungrounded DC and AC networks

Circuit diagrams

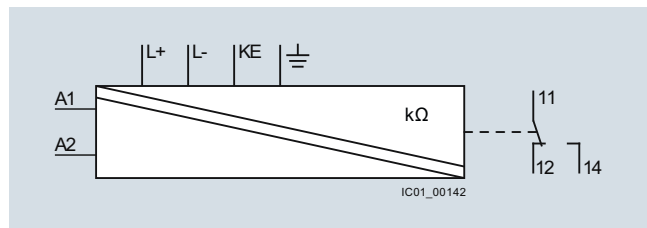

3UG4582

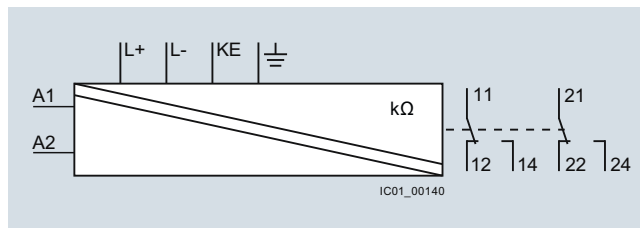

3UG4583

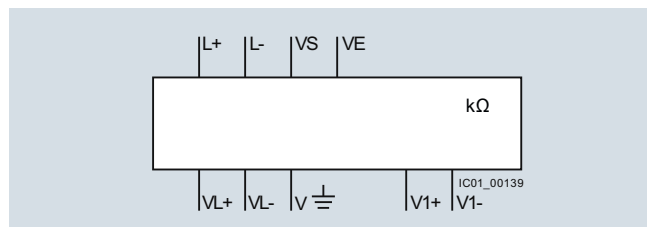

3UG4983

Note:

It is not necessary to protect the measuring circuit for device protection. The protective device for line protection depends on the cross-section used.

Connection diagrams

3UG4582

AC network, 2-wire, 3-wire or 4-wire

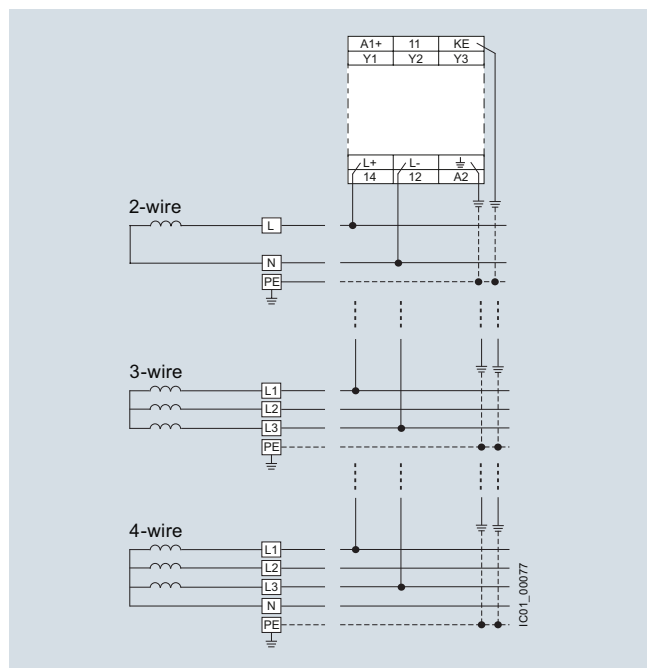

DC network, 2-wire or 3-wire

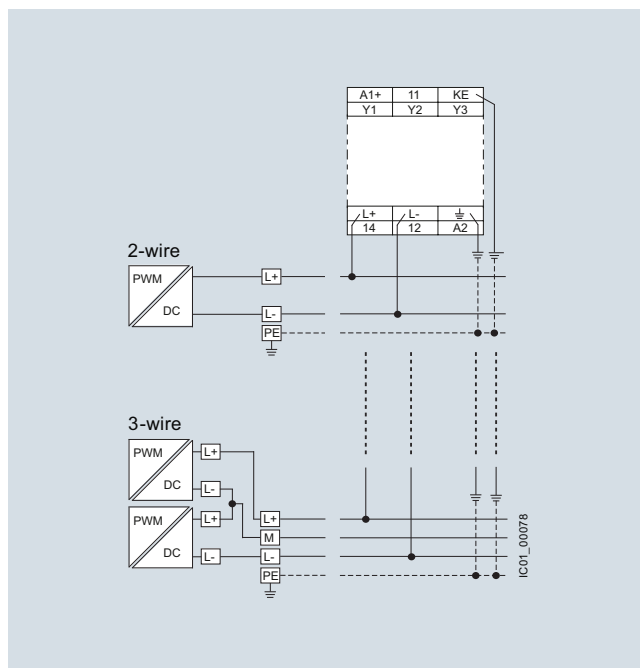

Note:

L+ and L- can be connected to any wire, but each to a different wire. $U_n \leq 250$ V AC or 300 V DC.

SIRIUS 3UG45, 3UG46 Monitoring Relays for Stand-Alone Installation Insulation Monitoring

For ungrounded DC and AC networks

3UG4583

AC network, 2-wire, 3-wire or 4-wire

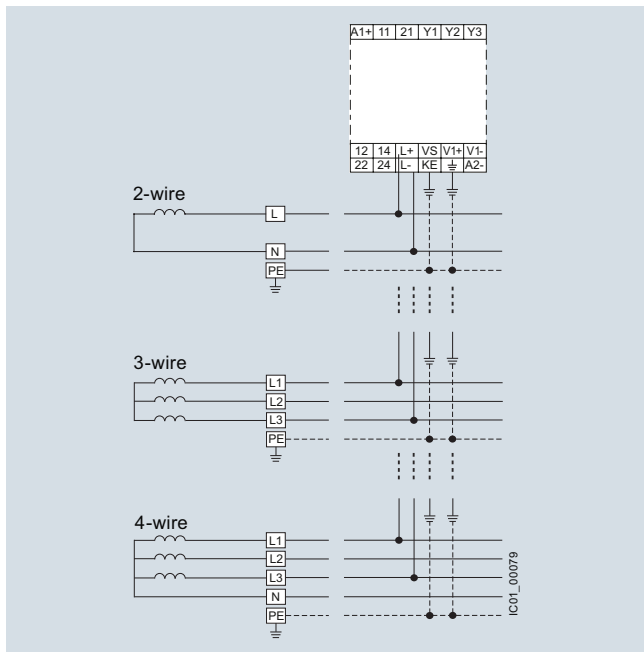

DC network, 2-wire or 3-wire

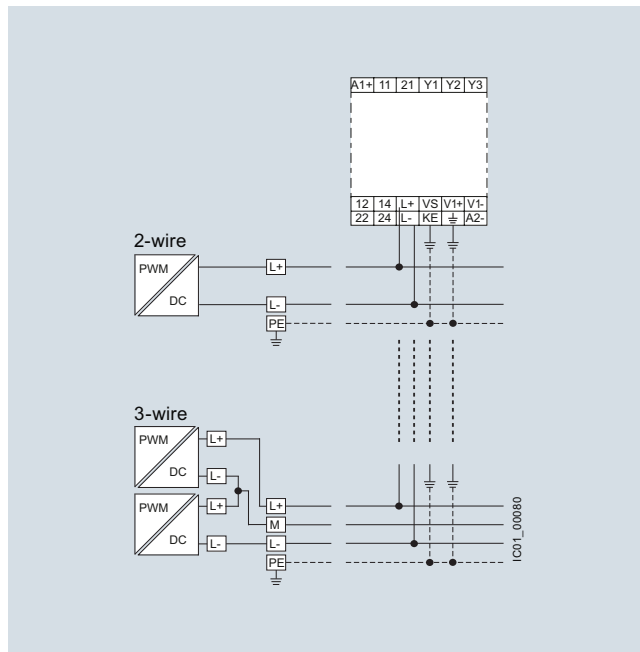

Note:

L+ and L- can be connected to any wire, but each to a different wire. $U_n \leq 400$ V AC or 600 V DC. Use a voltage reducer module to monitor systems with higher voltages.

3UG4983 voltage reducer module

AC network, 2-wire, 3-wire or 4-wire

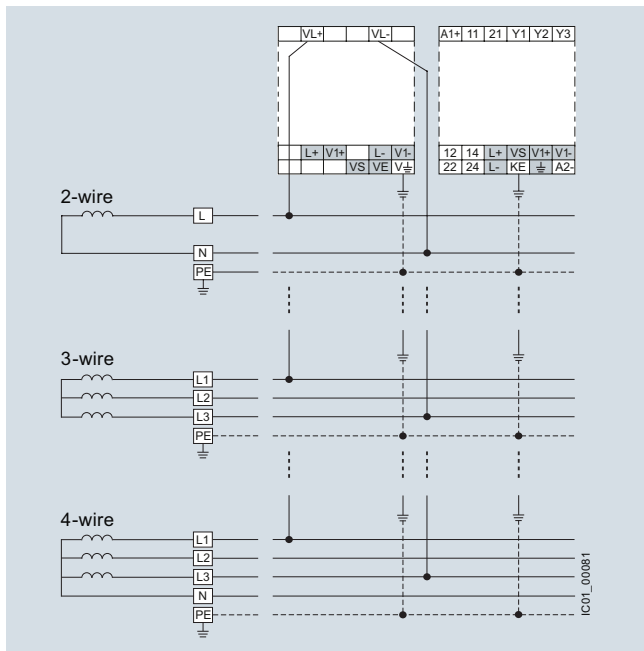

DC network, 2-wire or 3-wire

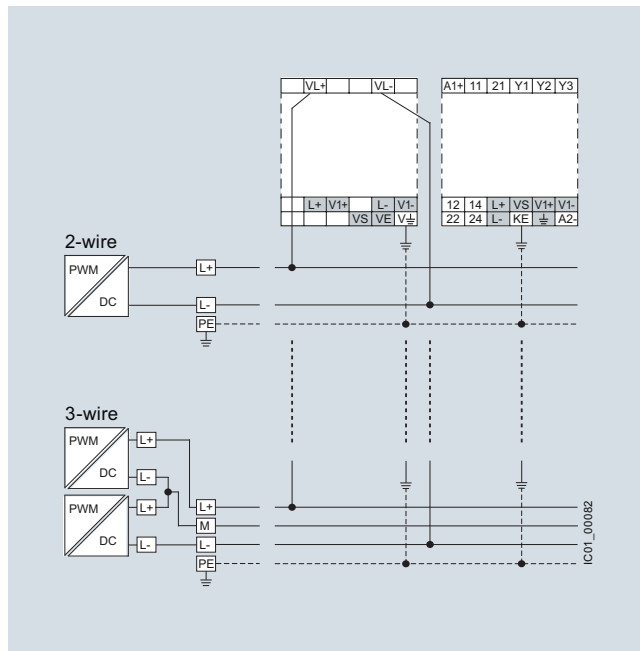

Note:

L+ and L- can be connected to any wire, but each to a different wire. $U_n \leq 400$ V AC or 600 V DC. Use a voltage reducer module to monitor systems with higher voltages.

Relays

SIRIUS 3UG45, 3UG46 Monitoring Relays for Stand-Alone Installation Insulation Monitoring



For ungrounded DC and AC networks

Selection and ordering data

- Auto or Manual RESET
- Rated control supply voltage U_c 24...240 V AC/DC
- 3UG4582: Closed-circuit principle
3UG4583: Open-circuit or closed-circuit principle, adjustable
- 1 or 2 CO contacts
- Fault memory adjustable using control input (Y2-Y3)
- Reset by means of button on front or using control input (Y2-Y3)
- Test by means of button on front or using control input (Y1-Y3)
- 3UG4583: Non-volatile fault storage can be configured
- 3UG4583: 2 separate limit values (e.g. for warning and disconnection) or 2 CO contacts for one limit value (e.g. for a local alarm and signaling to the PLC via separate circuits) can be configured

Note:

With the 3UG4983-1A coupling unit, connection to networks with a voltage of up to 690 V AC and 1 000 V DC is possible, see below.

	Rated mains voltage U_n	System leakage capacitance	Output relays	Measuring range U_e	Broken wire detection in the measuring range	DT	Screw terminals		PU (UNIT, SET, M)	PS*	PG
							Article No.	Price per PU			
	V	μF		k Ω							
3UG4582 insulation monitors											
	0 ... 250 AC, 0 ... 300 DC	Max. 10	1 CO	1 ... 100	✓	B	3UG4582-1AW30		1	1 unit	41H
3UG4583 insulation monitors											
	0 ... 400 AC, 0 ... 600 DC ¹⁾	Max. 20	2 CO or 1 CO + 1 CO, adjustable	1 ... 100, 2 ... 200 for 2nd limit value, adjustable	✓ Adjustable	B	3UG4583-1CW30		1	1 unit	41H
	Voltage reducer module for 3UG4583 For extending the mains voltage range to max. 690 V AC and 1 000 V DC					B	3UG4983-1A		1	1 unit	41H
✓ Available											

¹⁾ With 3UG4983-1A voltage reducer module suitable also for the insulation monitoring of IT networks up to 690 V AC and 1 000 V DC.

For accessories, see page 10/132.

Relays

SIRIUS 3UG45, 3UG46 Monitoring Relays for Stand-Alone Installation Level Monitoring

Level monitoring relays

Overview



SIRIUS 3UG4501 monitoring relay

The 3UG4501 level monitoring relay is used in combination with 2- or 3-pole sensors to monitor the levels of conductive liquids.

Benefits

- Can be used worldwide thanks to wide voltage range from 24 to 240 V (absolute limit values)
- Individually shortenable 2 and 3-pole wire electrodes for easy mounting from above/below
- Bow electrodes for installation from the side, for larger filling levels and minimum space requirements
- Can be flexibly adapted to different conductive liquids through analog setting of the sensitivity from 2 to 200 k Ω
- Compensation for wave movements through tripping delay times from 0.1 to 10 s
- Upstream or downstream function selectable
- All versions with removable terminals
- All versions with screw or spring-type terminals

Application

- Single-point and two-point level monitoring
- Overflow protection
- Dry run protection
- Leak monitoring

Technical specifications

3UG4501 monitoring relays

The principle of operation of the 3UG4501 level monitoring relay is based on measuring the electrical resistance of the liquid between two immersion sensors and a reference terminal. If the measured value is lower than the sensitivity set at the front, the output relay changes its switching state. In order to exclude electrolytic phenomena in the liquid, the sensors are supplied with alternating current.

Two-point control

The output relay changes its switching state as soon as the liquid level reaches the maximum sensor, while the minimum sensor is submerged. The relay returns to its original switching state as soon as the minimum sensor no longer has contact with the liquid.

OVER, two-point control

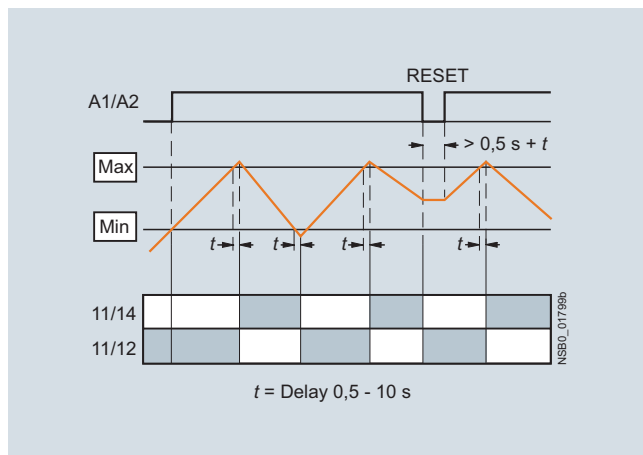

UNDER, two-point control

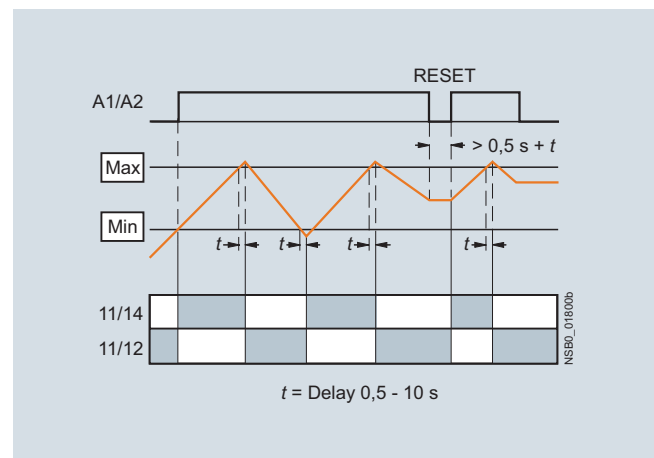

Note:

It is also possible to connect other resistance sensors to the Min and Max terminals in the range 2 to 200 k Ω , e.g. photoresistors, temperature sensors, encoders based on resistance, etc. The monitoring relay can therefore also be used for other applications as well as for monitoring the levels of liquids.

Relays

SIRIUS 3UG45, 3UG46 Monitoring Relays for Stand-Alone Installation Level Monitoring

Level monitoring relays

Single-point control

If only one level is being controlled, the terminals for Min and Max on the monitoring relay are bridged. The output relay changes its switching state as soon as the liquid level is reached and returns to its original switching state once the sensor no longer has contact with the liquid.

In order to prevent premature tripping of the switching function caused by wave motion or frothing, even though the set level has not been reached, it is possible to delay this function by 0.5 ... 10 s.

For safe resetting, the control supply voltage must be interrupted for at least the set delay time of +0.5 s.

OVER, single-point control

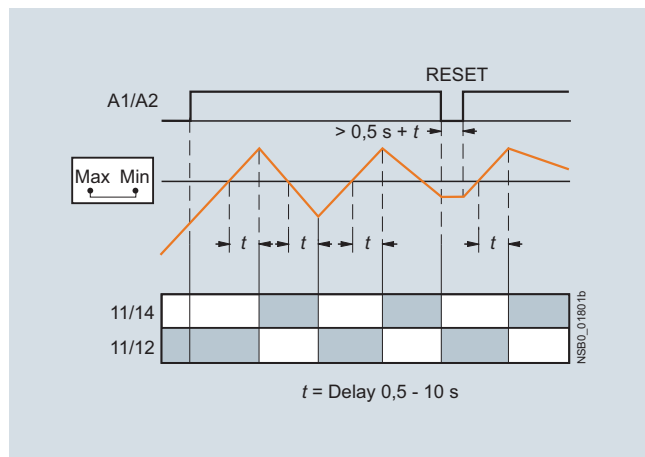

UNDER, single-point control

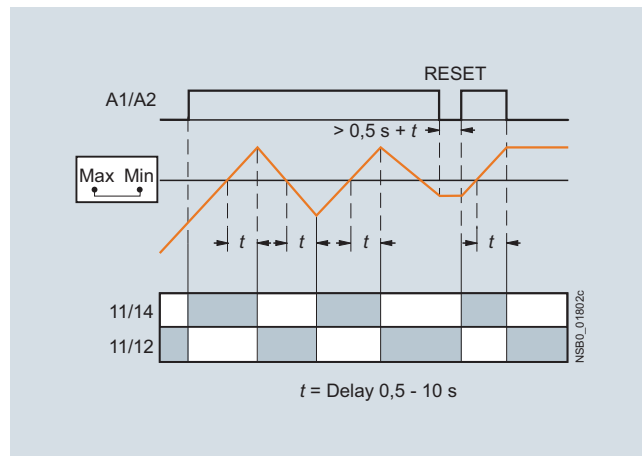

Type	3UG4501	
General data		
Rated insulation voltage U_i	V	300
Pollution degree 3, Overvoltage category III acc. to VDE 0110		
Rated impulse withstand voltage U_{imp}	kV	4
Measuring circuit		
Electrode current, max. (typ. 70 Hz)	mA	1
Electrode voltage, max. (typ. 70 Hz)	V	15
Sensor feeder cable	m	Max. 100
Conductor capacity of sensor cable¹⁾	nF	Max. 10
Control circuit		
Load capacity of the output relay	A	5
Conventional thermal current I_{th}		
Rated operational current I_o at	A	
• AC-15/24 ... 400 V	A	3
• DC-13/24 V	A	1
• DC-13/125 V	A	0.2
• DC-13/250 V	A	0.1
Minimum contact load at 17 V DC	mA	5

¹⁾ The sensor cable does not necessarily have to be shielded, but we do not recommend installing this cable parallel to the power supply lines. It is also possible to use a shielded cable, whereby the shield has to be connected to the M terminal.

Relays

SIRIUS 3UG45, 3UG46 Monitoring Relays for Stand-Alone Installation Level Monitoring

Level monitoring relays

Circuit diagrams

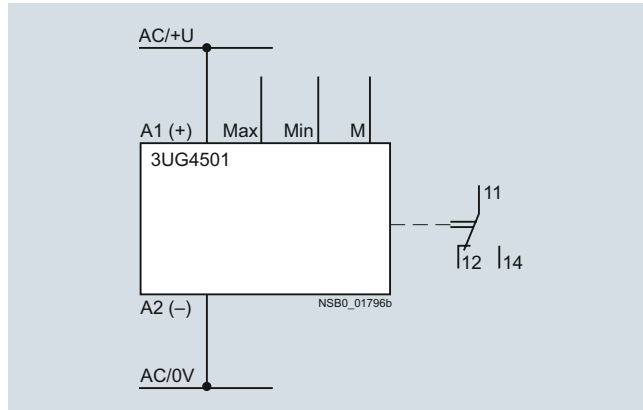

Schematic circuit diagram

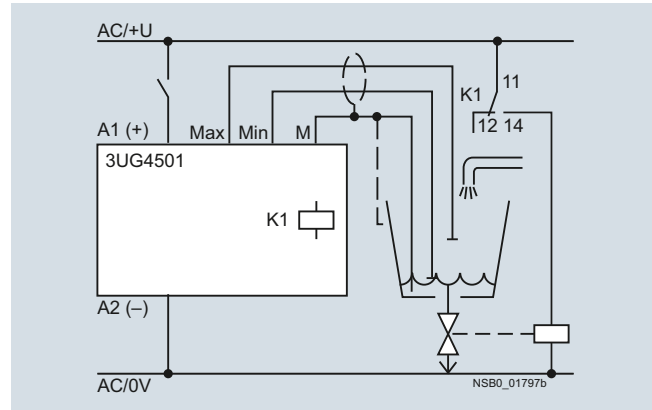

Circuit example of two-point control with outlet monitoring

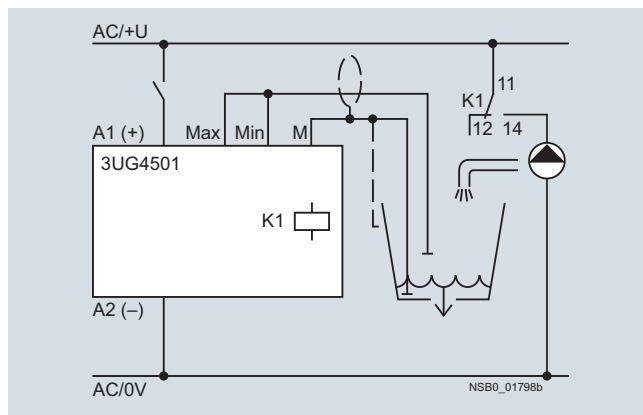



Circuit example of single-point control with inlet monitoring

Selection and ordering data

- For level monitoring of electrically conductive liquids
- Control principle: inlet or sequence control adjustable per rotary switch
- Single-point and two-point control possible
- Analogically adjustable sensitivity (specific resistance of the liquid)
- Analogically adjustable tripping delay time
- 1 yellow LED for displaying the relay state
- 1 green LED for displaying the applied control supply voltage
- 1 CO contact

PU (UNIT, SET, M) = 1
PS* = 1 unit
PG = 41H

Sensitivity	Tripping delay time	Rated control supply voltage U_s	DT	Screw terminals 	DT	Spring-type terminals 	
k Ω	s	V AC/DC		Article No.	Price per PU	Article No.	Price per PU
2 ... 200	0.5 ... 10	24 ¹⁾	A	3UG4501-1AA30	A	3UG4501-2AA30	
		24 ... 240	A	3UG4501-1AW30	A	3UG4501-2AW30	

¹⁾ The rated control supply voltage and the measuring circuit are not electrically separated.

For accessories, see page 10/132.

For level monitoring sensors, see page 10/128.

Relays

SIRIUS 3UG45, 3UG46 Monitoring Relays for Stand-Alone Installation Level Monitoring

Probes for filling level monitoring

Technical specifications

Type		3UG3207-3A Three-pole	3UG3207-2A Two-pole	3UG3207-2B Two-pole	3UG3207-1B Single-pole	3UG3207-1C Single-pole
Length	mm	500		--		
Insulation	Teflon insulation (PTFE)	Yes			--	Yes
Installation		Vertical		Lateral		
Screw-in gland width A/F		22				
Thread	Inch	R 3/8				
Connecting cable	mm ²	3 x 0.5, 2 m long				
Operating temperature	°C	90				
Operating pressure	bar	10				
Cable/electrode assignment						
• Cable brown		Center electrode	Not assignable	Gland		
• Cable white		Not assignable			Electrode	
• Cable green		Not assignable	--	Not assignable	--	

Dimensional drawings

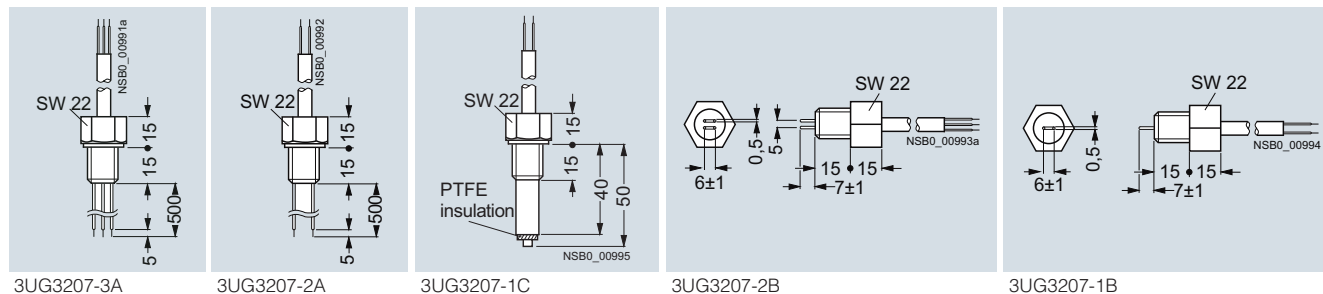

Selection and ordering data

Version	DT	Article No.	Price per PU	PU (UNIT, SET, M)	PS*	PG
---------	----	-------------	--------------	-------------------	-----	----

Level monitoring sensors (essential accessory)

The wire electrodes can be cut or bent to the required length before or after installation. The Teflon insulation must be removed over a length of approx. 5 mm.

Three-pole wire electrodes, 500 mm long

For 2-point liquid level control in an insulating tank. One electrode each for the min. and max. value and a common reference electrode.



3UG3207-3A

Two-pole wire electrodes, 500 mm long

For alarm indication in the event of overflow or low level and for 2-point liquid level control, when the conductive tank is used as the reference electrode.



3UG3207-2A

Two-pole bow electrodes

Thanks to the small space requirements due to lateral fitting, ideal for use in small containers and pipes, as a leak monitor and level monitor or for warning of water entering an enclosure.



3UG3207-2B

Single-pole bow electrodes for lateral fitting

As a max. value electrode for lateral fitting or for alarm indication in conductive tanks or pipes.



3UG3207-1B

Single-pole rod electrodes for lateral fitting

For high flow velocities or for intensively sparkling fluids.



3UG3207-1C

Overview

SIRIUS 3UG4651 monitoring relay

The 3UG4651 monitoring relay is used in combination with a sensor to monitor motor drives for overspeed and/or under-speed.

Furthermore, the monitoring relay is ideal for all functions where a continuous pulse signal needs to be monitored (e.g. belt travel monitoring, completeness monitoring, passing monitoring, clock-time monitoring).

Benefits

- Can be used worldwide thanks to wide voltage range from 24 to 240 V (absolute limit values)
- Variably adjustable to overshoot, undershoot or range monitoring
- Freely configurable delay times and RESET response
- Permanent display of actual value and fault type
- Use of up to 10 sensors per revolution on motors rotating extremely slowly
- 2- or 3-wire sensors and sensors with a mechanical switching output or semiconductor output can be connected
- Auxiliary voltage for sensor integrated
- All versions with removable terminals
- All versions with screw or spring-type terminals

Application

- Slip or tear of a belt drive
- Overload monitoring
- Transport monitoring for completeness

Technical specifications**3UG4651 monitoring relays**

The speed monitoring relay operates according to the principle of period duration measurement.

In the monitoring relay, the time between two successive rising edges of the pulse encoder is measured and compared to the minimum and/or maximum permissible period duration calculated from the set limit values for the speed.

Thus, the period duration measurement recognizes any deviation in speed after just two pulses, even at very low speeds or in the case of extended pulse gaps.

By using up to ten pulse encoders evenly distributed around the circumference, it is possible to shorten the period duration, and in turn the response time. By taking into account the number of sensors in the monitoring relay, the speed continues to be indicated in rpm.

ON-delay time for motor start

To be able to start a motor drive, and depending on whether the open-circuit or closed-circuit principle is selected, the output relay switches to the GO state during the ON-delay time, even if the speed is still below the set value.

The ON-delay time is started by either switching on the auxiliary voltage or, if the auxiliary voltage is already applied, by actuating the respective NC contact (e.g. auxiliary contact).

Speed monitoring with Auto RESET (Memory = no)

If the device is set to Auto RESET, the output relay switches to the GO state, once the adjustable hysteresis threshold is reached in the range of 0.1 ... 99.9 rpm and the flashing stops. Any overshoots or undershoots are therefore not stored.

Speed monitoring with Manual RESET (Memory = yes)

If Manual RESET is selected in the menu, the output relay remains in its current switching state and the current measured value and the symbol for overshooting/undershooting continue to flash, even when the speed returns to a permissible value. This stored fault status can be reset by pressing the UP▲ and DOWN▼ buttons simultaneously for > 2 s, by connecting the RESET device terminal to 24 V DC or by switching the control supply voltage off and back on again.

Relays

SIRIUS 3UG45, 3UG46 Monitoring Relays for Stand-Alone Installation

Speed monitoring

With the closed-circuit principle selected

Range monitoring without enable input

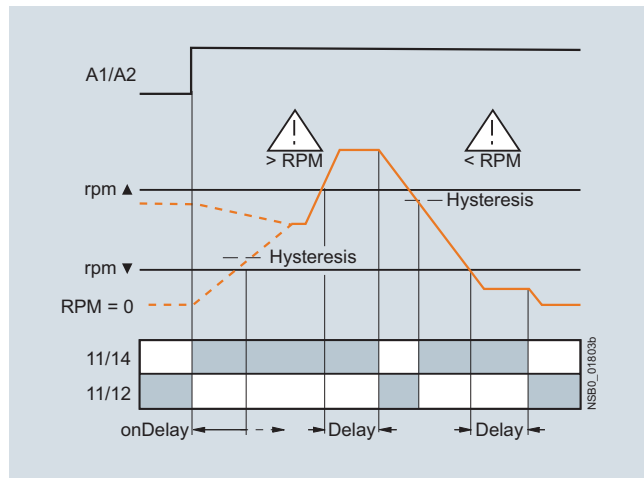

Range monitoring with enable input

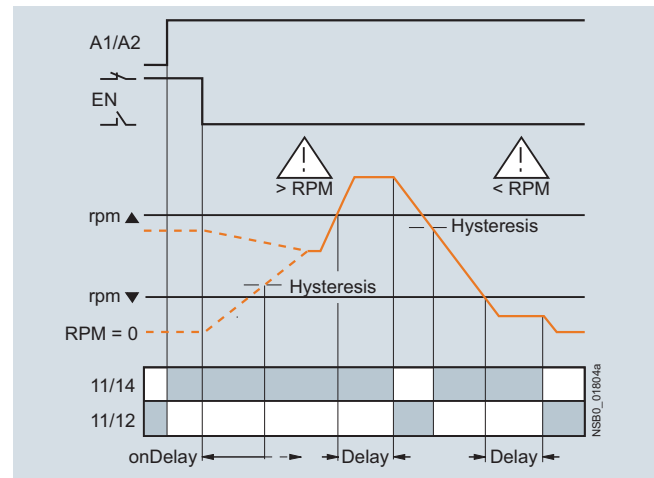

Type	3UG4651	
General data		
Rated insulation voltage U_i Pollution degree 3, Overvoltage category III acc. to VDE 0110	V	300
Rated impulse withstand voltage U_{imp}	kV	4
Measuring circuit		
Sensor supply		
• For three-wire sensor (24 V/0 V)	mA	Max. 50
• For 2-wire NAMUR sensor (8V2)	mA	Max. 8.2
Signal input		
• IN1	k Ω	16, three-wire sensor, pnp operation
• IN2	k Ω	1, floating contact, 2-wire NAMUR sensor
Voltage level		
• For level 1 at IN1	V	4.5 ... 30
• For level 0 at IN1	V	0 ... 1
Current level		
• For level 1 at IN2	mA	> 2.1
• For level 0 at IN2	mA	< 1.2
Minimum pulse duration of signal	ms	5
Minimum interval between 2 pulses	ms	5
Control circuit		
Number of CO contacts for auxiliary contacts		1
Load capacity of the output relay Conventional thermal current I_{th}	A	5
Rated operational current I_o at		
• AC-15/24 ... 400 V	A	3
• DC-13/24 V	A	1
• DC-13/125 V	A	0.2
• DC-13/250 V	A	0.1
Minimum contact load at 17 V DC	mA	5

Circuit diagrams

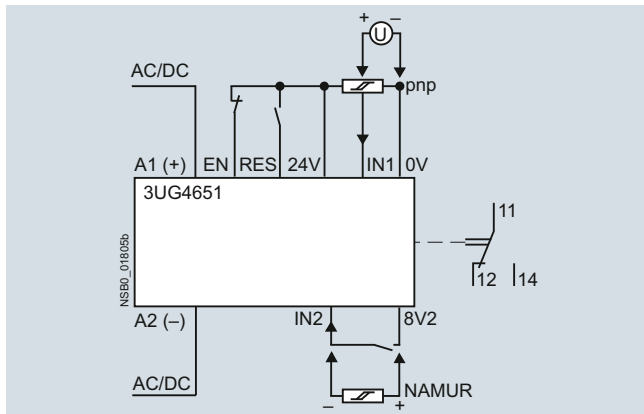

Schematic circuit diagram

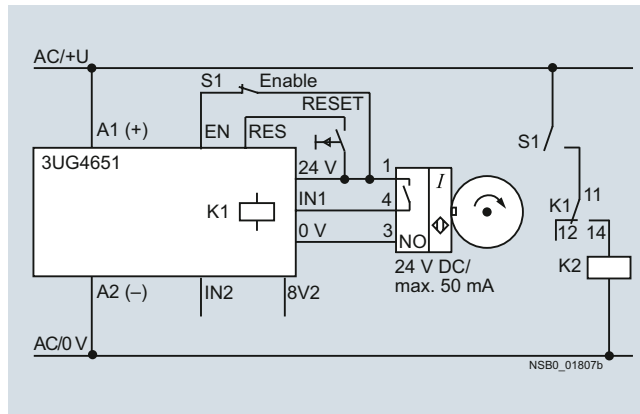

Circuit example with enable input

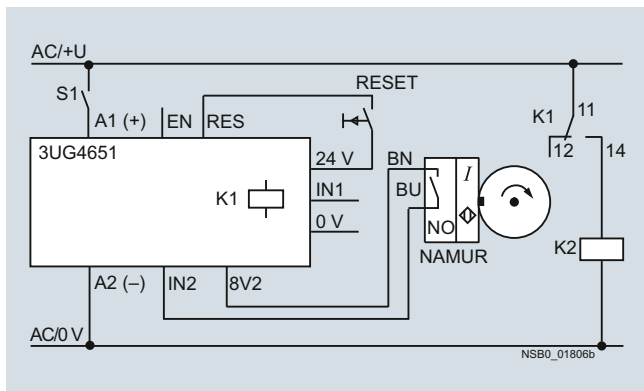

Circuit example without enable input

Selection and ordering data

- For speed monitoring in revolutions per minute (rpm)
- Two- or three-wire sensor with mechanical or electronic switching output can be connected
- Two-wire NAMUR sensor can be connected
- Sensor supply 24 V DC/50 mA integrated
- Input frequency 0.1 to 2 200 pulses rpm (0.0017 to 36.7 Hz)
- With or without enable signal for the drive to be monitored
- Digitally adjustable, with illuminated LCD
- Overshoot, undershoot or range monitoring adjustable
- Number of pulses per revolution can be adjusted
- Upper and lower threshold value can be adjusted separately
- Auto, manual or remote RESET options after tripping
- Permanent display of actual value and tripping state
- 1 CO contact

PU (UNIT, SET, M) = 1
 PS* = 1 unit
 PG = 41H

Measuring range	Hysteresis	ON-delay time	Tripping delay time	Pulses per revolution	Rated control supply voltage U_s	DT	Screw terminals	DT	Spring-type terminals
rpm	rpm	s	s		V				
0.1 ... 2 200	OFF 0.1 ... 99.9	0 ... 900	0.1 ... 99.9	1 ... 10	24 ¹⁾ 24 ... 240	A	Article No. 3UG4651-1AA30	Price per PU	Article No. 3UG4651-2AA30
						A	Article No. 3UG4651-1AW30	Price per PU	Article No. 3UG4651-2AW30

1) The rated control supply voltage and the measuring circuit are not electrically separated.







For accessories, see page 10/132.

Relays

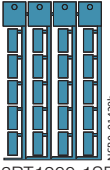
SIRIUS 3UG45, 3UG46 Monitoring Relays for Stand-Alone Installation

Accessories

Selection and ordering data

Use	Version	DT	Article No.	Price per PU	PU (UNIT, SET, M)	PS*	PG
Blank labels							
 3RT1900-1SB20	For 3UG4	Unit labeling plates For SIRIUS devices 20 mm x 7 mm, pastel turquoise ¹⁾	D	3RT1900-1SB20	100	340 units	41B
	For 3UG4	Adhesive labels For SIRIUS devices <ul style="list-style-type: none"> • 19 mm x 6 mm, pastel turquoise • 19 mm x 6 mm, zinc yellow 	C	3RT1900-1SB60	100	3 060 units	41B
				C	3RT1900-1SD60	100	3 060 units
Push-in lugs and covers							
 3RP1903	For 3UG4	Push-in lugs For screw fixing, 2 units are required for each device	B	3RP1903	1	10 units	41H
	For 3UG4	Sealable covers For securing against unauthorized adjustment of setting knobs	B	3RP1902	1	5 units	41H
 3RP1902	For 3UG45	Sealing foil For securing against unauthorized adjustment of setting knobs	▶	3TK2820-0AA00	1	1 unit	41L
Covers for insulation monitoring relays							
 3UG4981-0C	For 3UG4581 and 3UG4582	Sealable, transparent covers	B	3UG4981-0C	1	1 unit	41H
	For 3UG4583		B	3UG4983-0C	1	1 unit	41H
 3UG4983-0C							
Tools for opening spring-type terminals							
 3RA2908-1A	For auxiliary circuit connections	Screwdrivers For all SIRIUS devices with spring-type terminals 3.0 mm x 0.5 mm, length approx 200 mm, titanium gray/black, partially insulated	A	Spring-type terminals  3RA2908-1A	1	1 unit	41B

¹⁾ PC labeling system for individual inscription of unit labeling plates available from: murrplastik Systemtechnik GmbH, see Chapter 16, "Appendix" → "External Partners".

Notes:

Products for mechanical monitoring of bearings, see Chapter 15 "Products for Specific Requirements" → "Condition Monitoring Systems".

For more information, see www.siemens.com/siplus-cms.

Overview



SIRIUS 3UG48 monitoring relays

The SIRIUS 3UG4 monitoring relays for electronic and mechanical variables monitor all important characteristics that allow conclusions to be drawn about the functionality of a plant. Both sudden disturbances and gradual changes, which may indicate the need for maintenance, are detected.

Thanks to their relay outputs, the monitoring relays permit direct disconnection of the affected system components as well as alerting e.g. by triggering a warning light. Thanks to adjustable delay times the 3UG4 monitoring relays can respond very flexibly to brief faults such as voltage dips or load changes and can thus avoid unnecessary alarms and disconnections and increase system availability.

3UG48 monitoring relays for IO-Link

The SIRIUS 3UG48 monitoring relays for IO-Link also offer many other options based upon the monitoring functions of the tried-and-tested SIRIUS 3UG4 monitoring relays:

- Measured value transmission to a controller, including resolution and unit, may be parameterizable as to which value is cyclically transmitted
- Transmission of alarm flags to a controller
- Full diagnosis capability by inquiry as to the cause of the fault in the diagnosis data record
- Remote parameterization is also possible, in addition to or instead of local parameterization
- Rapid parameterization of the same devices by duplication of the parameterization in the controller
- Parameter transmission by upload to a controller by IO-Link call or by parameter server (if IO-Link master from IO-Link Specification V1.1 and higher is used)
- Consistent central data storage in the event of parameter change locally or via a controller
- Automatic reparameterizing when devices are exchanged
- Blocking of local parameterization via IO-Link possible
- Faults are saved in parameterizable and non-volatile fashion to prevent an automatic start up after voltage failure and to make sure diagnostics data is not lost
- Integration into the automation level provides the option of parameterizing the monitoring relays at any time via a display unit, or displaying the measured values in a control room or locally at the machine/control cabinet.

Even without communication via IO-Link the devices continue to function fully autonomously:

- Parameterization can take place locally at the device, independently of a controller
- In the event of failure or before the controller becomes available the monitoring relays work as long as the control supply voltage (24 V DC) is present
- If the monitoring relays are operated without the controller, the 3UG48 monitoring relays have, thanks to the integrated SIO mode, an additional semiconductor output, which switches when the adjustable warning threshold is exceeded

Thanks to the combination of autonomous monitoring relay function and integrated IO-Link communication, redundant sensors and/or analog signal converters – which previously took over the transmission of measured values to a controller, leading to considerable extra cost and wiring outlay – are no longer needed.

Because the output relays are still present, the monitoring relays increase the functional reliability of the system, since only the controller can fulfill the control tasks if the current measured values are available, whereas the output relays can also be used for the disconnection of the system if limit values that cannot be reached during operation are exceeded.

The individual 3UG48 monitoring relays for IO-Link offer the following functions in different combinations:

- Phase sequence
- Phase failure, neutral conductor failure
- Phase asymmetry
- Undershooting and/or overshooting of limit values for voltage
- Undershooting and/or overshooting of limit values for current
- Undershooting and/or overshooting of power factor limit values
- Monitoring of the active current or the apparent current
- Monitoring of the residual current
- Undershooting and/or overshooting of limit values for speed

Note:

Further information on the IO-Link bus systems, see [Chapter 2 "Industrial Communication"](#).

Notes on safety

System networking requires suitable protective measures (including network segmentation for IT security) in order to ensure safe plant operation.

More information about the subject of Industrial Security, see www.siemens.com/industrialsecurity.

Relays

SIRIUS 3UG48 Monitoring Relays for Stand-Alone Installation for IO-Link NEW

General data

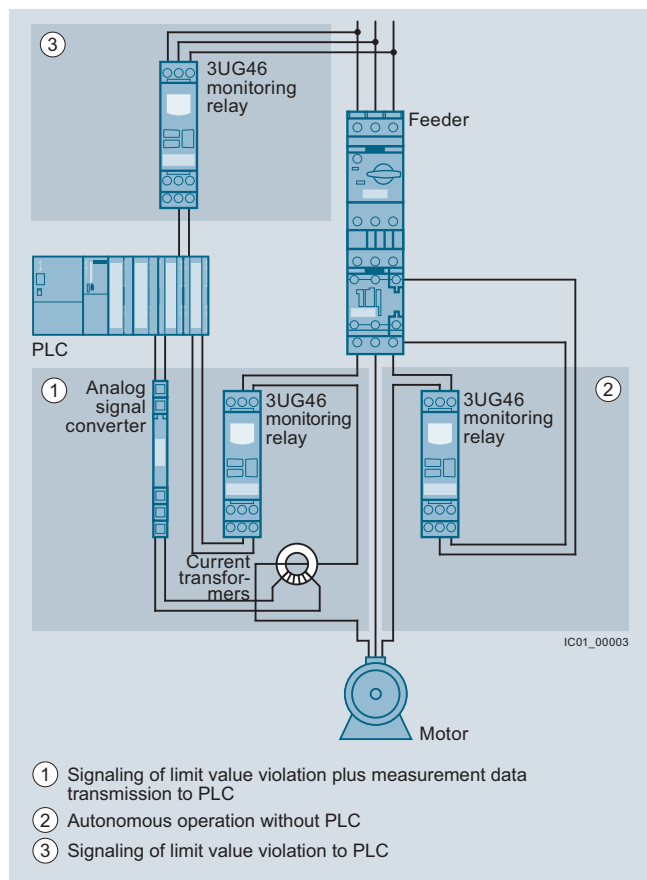

Use of conventional monitoring relays

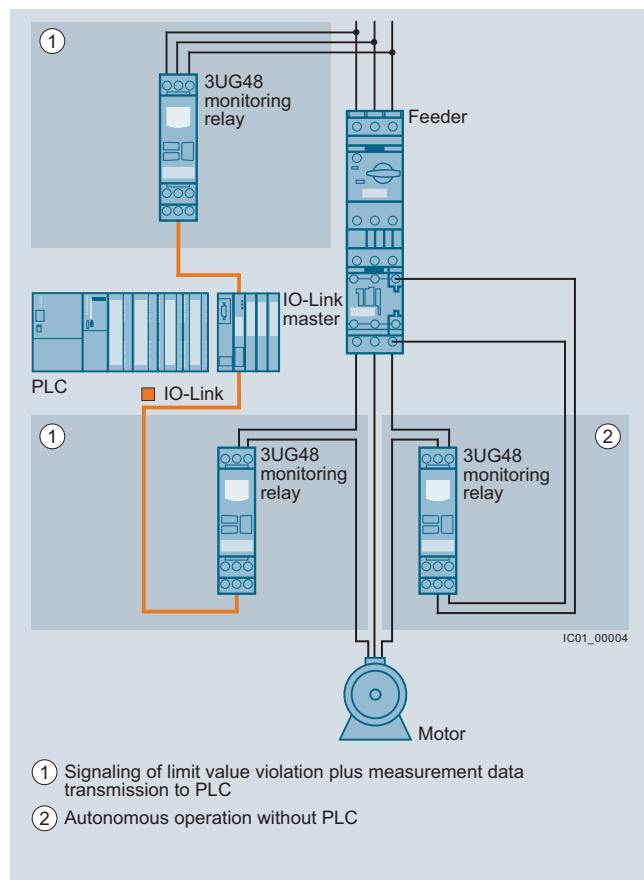

Monitoring relays for IO-Link

Notes:

Devices required for the communication via IO-Link:

- Any controller that supports the IO-Link (e.g. ET 200SP with CPU or S7-1200), see [Catalog ST 70 "Products for Totally Integrated Automation"](#)

- IO-Link-Master (e.g. CM 4xIO-Link for SIMATIC ET 200SP or SM 1278 for S7-1200), see [Catalog ST 70 "Products for Totally Integrated Automation"](#)

Each monitoring relay requires an IO-Link channel.

Article No. scheme

Digit of the Article No.	1st - 3rd	4th	5th	6th	7th	8th	9th	10th	11th	12th
Monitoring relays	<input type="checkbox"/> <input type="checkbox"/> <input type="checkbox"/>	<input type="checkbox"/>	<input type="checkbox"/>	<input type="checkbox"/>	<input type="checkbox"/>	-	<input type="checkbox"/>	<input type="checkbox"/>	<input type="checkbox"/>	<input type="checkbox"/>
Generation	3 U G			<input type="checkbox"/>						
Type of setting			<input type="checkbox"/>							
Functions				<input type="checkbox"/>	<input type="checkbox"/>					
Connection methods							<input type="checkbox"/>			
Contacts								<input type="checkbox"/>		
Supply voltage								<input type="checkbox"/>		
Signal type of the control supply voltage									<input type="checkbox"/>	
Special version										<input type="checkbox"/>
Example	3 U G	4	8	1	5	-	1	A	A	4 0

Note:

The Article No. scheme is presented here merely for information purposes and for better understanding of the logic behind the article numbers.

For your orders, please use the article numbers quoted in the catalog in the Selection and ordering data.

Benefits

- Simple cyclical transmission of the current measured values, relay switching states and events to a controller
- Remote parameterization
- Automatic reparameterizing when devices are exchanged
- Simple duplication of identical or similar parameterizations
- Reduction of control current wiring
- Elimination of testing costs and wiring errors
- Reduction of configuration work
- Integration in TIA means clear diagnostics if a fault occurs
- Cost saving and space saving in control cabinet due to the elimination of AI and IO modules as well as analog signal converters and duplicated sensors

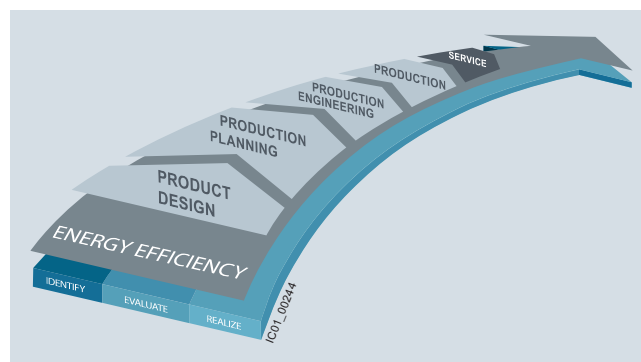
Advantages through energy efficiency

Overview of the energy management process

We offer you a unique portfolio for industrial energy management, using an energy management system that helps to optimally define your energy needs. We split up our industrial energy management into three phases – identify, evaluate, and realize – and we support you with the appropriate hardware and software solutions in every process phase.

The innovative SIRIUS industrial controls products can also make a major contribution to the energy efficiency of a plant (www.siemens.com/sirius/energysaving).

The 3UG48 monitoring relays for IO-Link contribute to the energy efficiency throughout the plant as follows:

- Shutdown in the event of no-load operation (e.g. pump no-load operation)
- Reactive-power compensation by means of power factor monitoring
- Load shedding of predefined loads in the event of current overshoots

Application

The use of SIRIUS monitoring relays for IO-Link is particularly recommended for machines and plant in which these relays, in addition to their monitoring function, are to be connected to the automation level for the rapid, simple and fault-free provision of the current measured values and/or for remote parameterization.



The monitoring relays can either relieve the controller of monitoring tasks or, as a second monitoring entity in parallel to and independent of the controller, increase the reliability in the process or in the system. In addition, the elimination of AI and IO modules allows the width of the controller to be reduced despite significantly expanded functionality.

Relays

SIRIUS 3UG48 Monitoring Relays for Stand-Alone Installation for IO-Link **NEW**

General data

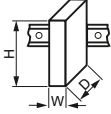
Technical specifications

Type	3UG48	
General technical specifications		
Dimensions (W x H x D)		
<ul style="list-style-type: none"> For 3 terminal blocks <ul style="list-style-type: none"> Screw terminals Spring-type terminals For 4 terminal blocks <ul style="list-style-type: none"> Screw terminals Spring-type terminals 		mm 22.5 x 92 x 91 mm 22.5 x 94 x 91 mm 22.5 x 103 x 91 mm 22.5 x 103 x 91
Permissible ambient temperature		
<ul style="list-style-type: none"> During operation 	°C	-25 ... +60
Connection type		 Screw terminals
<ul style="list-style-type: none"> Terminal screw Solid Finely stranded with end sleeve AWG cables, solid or stranded Tightening torque 	mm ² mm ² AWG Nm	M3 (for standard screwdriver, size 2 and Pozidriv 2) 1 x (0.5 ... 4), 2 x (0.5 ... 2.5) 1 x (0.5 ... 2.5), 2 x (0.5 ... 1.5) 2 x (20 ... 14) 0.8 ... 1.2
Connection type		 Spring-type terminals
<ul style="list-style-type: none"> Solid Finely stranded, with end sleeves acc. to DIN 46228 Finely stranded AWG cables, solid or stranded 	mm ² mm ² mm ² AWG	2 x (0.25 ... 1.5) 2 x (0.25 ... 1.5) 2 x (0.25 ... 1.5) 2 x (24 ... 16)

More information

Manual "3UG48/3RR24 Monitoring Relays for IO-Link", see <http://support.automation.siemens.com/WW/view/en/54375430>.

Notes on safety

System networking requires suitable protective measures (including network segmentation for IT security) in order to ensure safe plant operation.

More information about the subject of Industrial Security, see www.siemens.com/industrialsecurity.

Overview

SIRIUS 3UG4815 monitoring relay

Solid-state line monitoring relays provide maximum protection for mobile machines, plants and hoisting equipment or for unstable networks. Network and voltage faults can thus be detected early and rectified before far greater damage ensues.

The line monitoring relays with IO-Link monitor phase sequence, phase failure (with or without N conductor monitoring), phase asymmetry and undervoltage and/or overvoltage.

Phase asymmetry is evaluated as the difference between the greatest and the smallest phase voltage relative to the greatest phase voltage. Undervoltage or overvoltage exist if the set limit values for at least one phase voltage are overshoot or undershot. The rms value of the voltage is measured.

Benefits

- Can be used in any network from 160 to 630 V AC worldwide thanks to wide voltage range
- Variably adjustable to overshoot, undershoot or range monitoring
- Freely configurable delay times and RESET response
- Width 22.5 mm
- Display and transmission of actual value and network fault type to controller
- All versions with removable terminals
- All versions with screw or spring-type terminals

Application

The relays are used above all for mobile equipment, e.g. air conditioning compressors, refrigerating containers, building site compressors and cranes.

Function	Application
Phase sequence	<ul style="list-style-type: none"> • Direction of rotation of the drive
Phase failure	<ul style="list-style-type: none"> • A fuse has tripped • Failure of the control supply voltage • Broken cable
Phase asymmetry	<ul style="list-style-type: none"> • Overheating of the motor due to asymmetrical voltage • Detection of asymmetrically loaded networks
Undervoltage	<ul style="list-style-type: none"> • Increased current on a motor with corresponding overheating • Unintentional resetting of a device • Network collapse, particularly with battery power
Overvoltage	<ul style="list-style-type: none"> • Protection of a plant against destruction due to overvoltage

Relays

SIRIUS 3UG48 Monitoring Relays for Stand-Alone Installation for IO-Link **NEW**

Line monitoring

Technical specifications

3UG4815/3UG4816 monitoring relays

The 3UG4815 and 3UG4816 line monitoring relays have a wide voltage range input and are supplied with power through IO-Link or from an external 24 V DC source.

The device is equipped with a display and is parameterized using three buttons. The 3UG4815 monitoring relay monitors three-phase networks with regard to phase sequence, phase failure, phase asymmetry, undervoltage and overvoltage. The 3UG4816 monitoring relay monitors the neutral conductor as well. The hysteresis is adjustable from 1 to 20 V.

The device has two separately adjustable delay times for overvoltage and undervoltage and for line stabilization. If the direction of rotation is incorrect or a phase fails, the device switches off immediately. Thanks to a special measuring method, a phase failure is reliably detected in spite of the wide voltage range from and potentially high feedback through the load.

The 3UG4815 and 3UG4816 monitoring relays can be operated on the basis of either the open-circuit or closed-circuit principle and with Manual or Auto RESET.

If Manual RESET is selected in the menu (Memory = Yes), the switching relay remains in its current switching state and the current measured value and the symbol for undershooting and overshooting continues to flash, even when the measured variable reaches a permissible value again. This stored fault status can be reset by simultaneously pressing the UP▲ or DOWN▼ key for 2.5 s.

With Manual RESET through IO-Link it is possible in addition to set whether error signals are to be deleted when the control supply voltage is switched off and on (as remote RESET) or whether the signals are to be permanently saved even in a voltage failure, with confirmation possible only through local RESET or via IO-Link.

With the closed-circuit principle selected

Wrong phase sequence

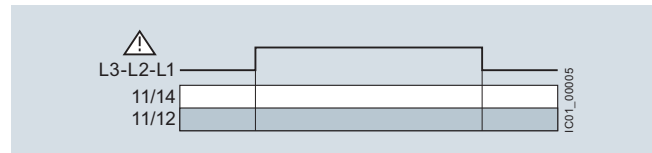

Phase failure

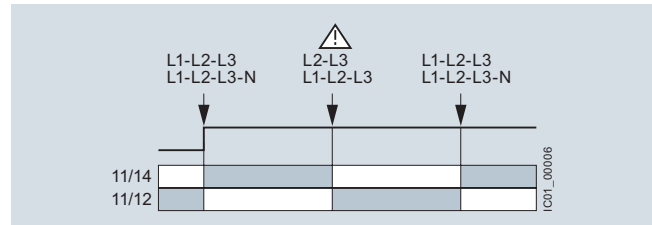

Undervoltage

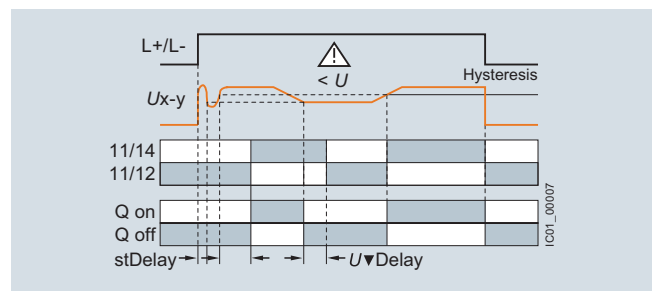

Overvoltage

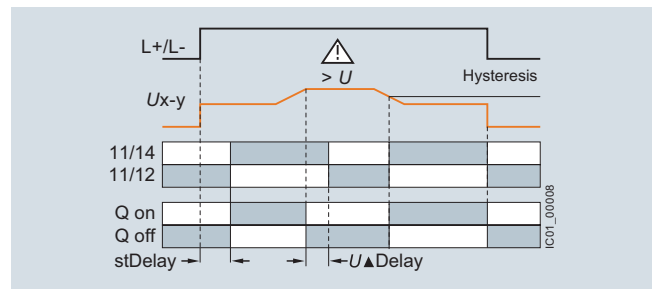

Type	3UG4815, 3UG4816	
General technical specifications		
Rated insulation voltage U_i	V	690
Pollution degree 2 Overvoltage category III acc. to VDE 0110		
Rated impulse withstand voltage U_{imp}	kV	6
Control circuit		
Load capacity of the output relay		
• Conventional thermal current I_{th}	A	5
Rated operational current I_o at		
• AC-15/24 ... 400 V	A	3
• DC-13 at		
- 24 V	A	1
- 125 V	A	0.2
- 250 V	A	0.1
Minimum contact load at 17 V DC	mA	5
Electrical endurance AC-15	Million operating cycles	0.1
Mechanical endurance	Million operating cycles	10

NEW SIRIUS 3UG48 Monitoring Relays for Stand-Alone Installation for IO-Link

Line monitoring

Circuit diagrams

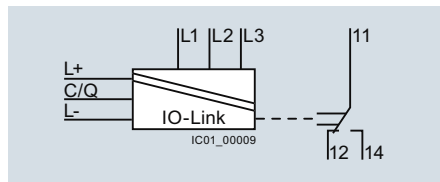

3UG4815

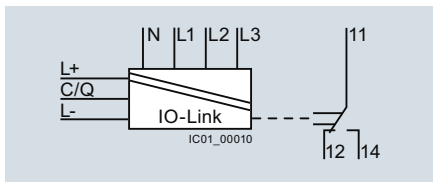

3UG4816

Note:

It is not necessary to protect the measuring circuit for device protection. The protective device for line protection depends on the cross-section used.

Selection and ordering data

- Adjustable via IO-Link and locally, with illuminated LCD
- Power supply with 24 V DC via IO-Link or external auxiliary voltage
- Auto or Manual RESET
- Open or closed-circuit principle
- 1 CO contact, 1 semiconductor output (in SIO mode)

PU (UNIT, SET, M) = 1
 PS* = 1 unit
 PG = 41H



Adjustable hysteresis	Under-voltage detection	Over-voltage detection	Stabilization time adjustable stDEL	Tripping delay time adjustable Del	Version of auxiliary contacts	Measurable mains voltage ¹⁾	DT	Screw terminals	DT	Spring-type terminals	
V			s	s		V AC		Article No.	Price per PU	Article No.	Price per PU
Monitoring of phase sequence, phase failure, phase asymmetry, overvoltage and undervoltage											
1 ... 20	✓	✓	0.1 ... 999.9	0.1 ... 999.9	1 CO + 1 Q ²⁾	160 ... 690	A	3UG4815-1AA40	A	3UG4815-2AA40	
Monitoring of phase sequence, phase and N conductor failure, phase asymmetry, overvoltage and undervoltage											
1 ... 20	✓	✓	0.1 ... 999.9	0.1 ... 999.9	1 CO + 1 Q ²⁾	90 ... 400 against N	A	3UG4816-1AA40	A	3UG4816-2AA40	

✓ Function available

¹⁾ Absolute limit values.

²⁾ In SIO mode.

For accessories, see page 10/156.

Relays

SIRIUS 3UG48 Monitoring Relays for Stand-Alone Installation for IO-Link **NEW**

Voltage monitoring

Overview



SIRIUS 3UG4832 monitoring relays

The relays monitor single-phase AC voltages (rms value) and DC voltages against the set limit value for overshoot and undershoot.

Benefits

- Variably adjustable to overshoot, undershoot or range monitoring
- Freely configurable delay times and RESET response
- Width 22.5 mm
- Display and transmission of actual value and status messages to controller
- All versions with removable terminals
- All versions with screw or spring-type terminals

Application

- Protection of a plant against destruction due to overvoltage
- Switch-on of a plant at a defined voltage and higher
- Protection from undervoltage due to overloaded control supply voltages, particularly with battery power

Technical specifications

3UG4832 monitoring relay

The 3UG4832 voltage monitoring relays are supplied with power through IO-Link or with an external auxiliary voltage of 24 V DC and perform overshoot, undershoot or range monitoring of the voltage depending on parameterization. The devices are equipped with a display and are parameterized by means of three buttons or through IO-Link.

The measuring range extends from 10 to 600 V AC/DC. The limit values for overshoot or undershoot can be freely configured within this range. If one of these limit values is reached, the output relay responds according to the set principle of operation as soon as the delay time has elapsed. This tripping delay time $U\blacktriangle\text{Del}/U\blacktriangledown\text{Del}$ can be set from 0 to 999.9 s like the ON-delay time. The hysteresis is adjustable from 0.1 to 300 V.

The device can be operated on the basis of either the open-circuit or closed-circuit principle and with Manual or Auto RESET. One output changeover contact is available as a signaling contact, and a semiconductor output is available in addition in SIO mode.

If Manual RESET is selected in the menu (Memory = Yes), the switching relay remains in its current switching state and the current measured value and the symbol for undershooting and overshooting continues to flash, even when the measured variable reaches a permissible value again. This stored fault status can be reset by simultaneously pressing the UP \blacktriangle or DOWN \blacktriangledown key for 2.5 s.

With Manual RESET through IO-Link it is possible in addition to set whether error signals are to be deleted when the control supply voltage is switched off and on (as remote RESET) or whether the signals are to be permanently saved even in a voltage failure, with confirmation possible only through local RESET or via IO-Link.

With the closed-circuit principle selected

Overvoltage

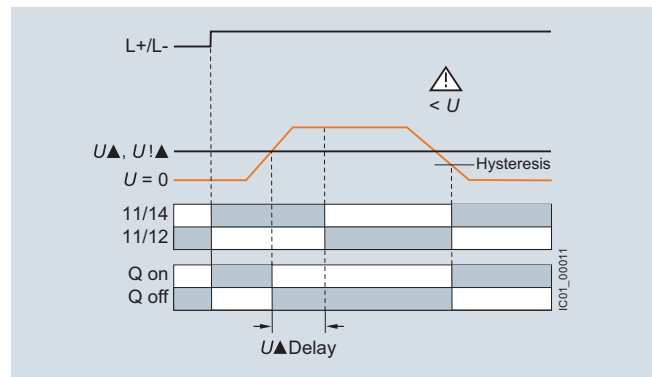

Undervoltage

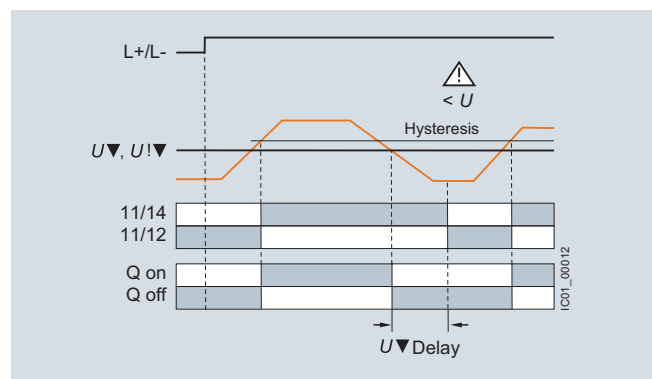

With the closed-circuit principle selected

Range monitoring

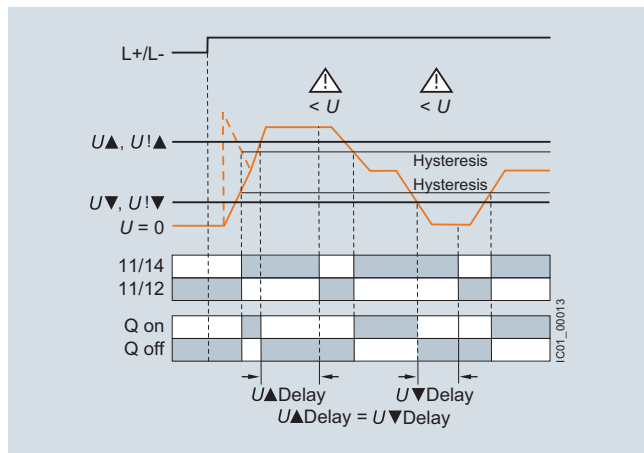

Type	3UG4832	
General technical specifications		
Rated insulation voltage U_i Pollution degree 2 Overvoltage category III according to VDE 0110	V	690
Rated impulse withstand voltage U_{imp}	kV	6
Measuring circuit		
Permissible measuring range single-phase AC/DC voltage	V	10 ... 690
Setting range single-phase voltage	V	10 ... 600
Measuring frequency	Hz	40 ... 500
Control circuit		
Load capacity of the output relay • Conventional thermal current I_{th}		
	A	5
Rated operational current I_o at		
• AC-15/24 ... 400 V	A	3
• DC-13 at		
- 24 V	A	1
- 125 V	A	0.2
- 250 V	A	0.1
Minimum contact load at 17 V DC	mA	5

Circuit diagram

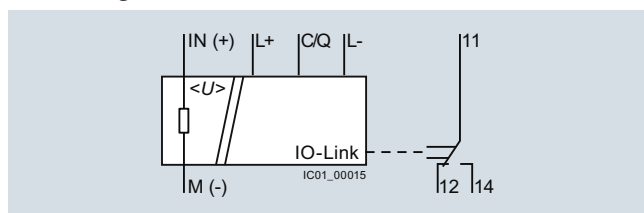

3UG4832

Note:

It is not necessary to protect the measuring circuit for device protection. The protective device for line protection depends on the cross-section used.

Relays

SIRIUS 3UG48 Monitoring Relays for Stand-Alone Installation for IO-Link **NEW**

Voltage monitoring

Selection and ordering data

- Adjustable via IO-Link and locally, with illuminated LCD
- Power supply with 24 V DC via IO-Link or external auxiliary voltage
- Auto or Manual RESET
- Open or closed-circuit principle
- 1 CO contact, 1 semiconductor output (in SIO mode)



PU (UNIT, SET, M) = 1
 PS* = 1 unit
 PG = 41H



3UG4832-1AA40



3UG4832-2AA40

Measuring range	Adjustable hysteresis	ON-delay time adjustable onDel	Tripping delay time separately adjustable U Δ Del/U ∇ Del	DT	Screw terminals 	DT	Spring-type terminals 	
V AC/DC	V	s	s		Article No.	Price per PU	Article No.	Price per PU
Monitoring of voltage for overshoot and undershoot								
10 ... 600	0.1 ... 300	0 ... 999.9	0 ... 999.9	A	3UG4832-1AA40	A	3UG4832-2AA40	

For accessories, see page 10/156.

Overview

SIRIUS 3UG4822 monitoring relays

The relays monitor single-phase AC (rms value) and DC currents against the set limit value for overshoot and undershoot.

Benefits

- Variably adjustable to overshoot, undershoot or range monitoring
- Freely configurable delay times and RESET response
- Width 22.5 mm
- Display and transmission of actual value and status messages to controller
- All versions with removable terminals
- All versions with screw or spring-type terminals

Application

- Overcurrent and undercurrent monitoring
- Monitoring the functionality of electrical loads
- Monitoring for broken conductors

Technical specifications**3UG4822 monitoring relays**

The 3UG4822 current monitoring relays are supplied with power through IO-Link or with an external voltage of 24 V DC and perform overshoot, undershoot or range monitoring of the current depending on the parameterization. The devices are equipped with a display and are parameterized using three buttons.

The measuring range extends from 0.05 to 10 A. For larger AC currents the measuring range can be extended by using commercially available current transformers. Using the adjustable transformer factor, the display of the measured primary currents up to 750 A instead of the secondary currents (max. 1 A or 5 A) is possible.

The rms value of the current is measured. The limit values for overshoot or undershoot can be freely configured within this range. If one of these limit values is reached, the output relay responds according to the set principle of operation as soon as the tripping delay time $I\blacktriangle\text{Del}/I\blacktriangledown\text{Del}$ has elapsed. This time and the ON-delay time onDel are adjustable from 0 to 999.9 s.

The hysteresis is adjustable from 0.01 to 5 A. The device can be operated with Manual or Auto RESET and on the basis of either the open-circuit or closed-circuit principle. Following options are available: Response of the output relay when the control supply voltage $U_s = \text{ON}$ is applied or not until the lower measuring range limit of the measuring current ($I > 50 \text{ mA}$) is reached. One output changeover contact is available as a signaling contact, and a semiconductor output is available in addition in SIO mode.

If Manual RESET is selected in the menu (Memory = Yes), the switching relay remains in its current switching state and the current measured value and the symbol for undershooting and overshooting continues to flash, even when the measured variable reaches a permissible value again. This stored fault status can be reset by simultaneously pressing the UP \blacktriangle or DOWN \blacktriangledown key for 2.5 s.

With Manual RESET through IO-Link it is possible in addition to set whether error signals are to be deleted when the control supply voltage is switched off and on (as remote RESET) or whether the signals are to be permanently saved even in a voltage failure, with confirmation possible only through local RESET or via IO-Link.

With the closed-circuit principle selected upon application of the control supply voltage

Current overshoot

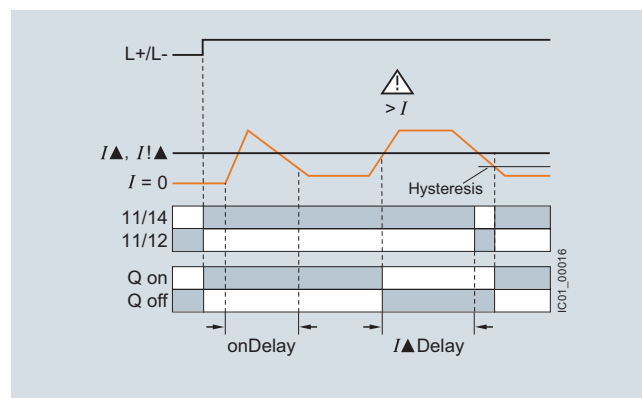

Current undershoot

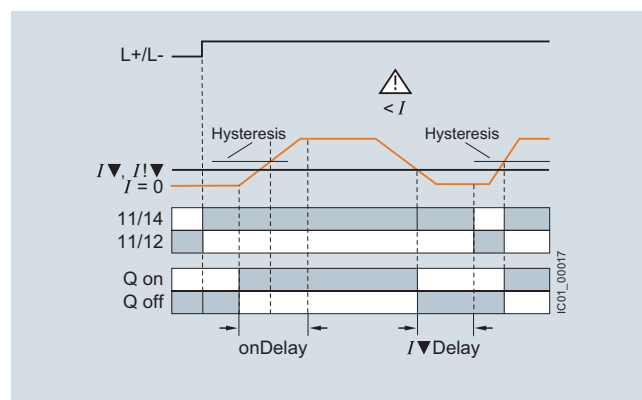

Relays

SIRIUS 3UG48 Monitoring Relays for Stand-Alone Installation for IO-Link

NEW

Current monitoring

With the closed-circuit principle selected
upon application of the control supply voltage

Range monitoring

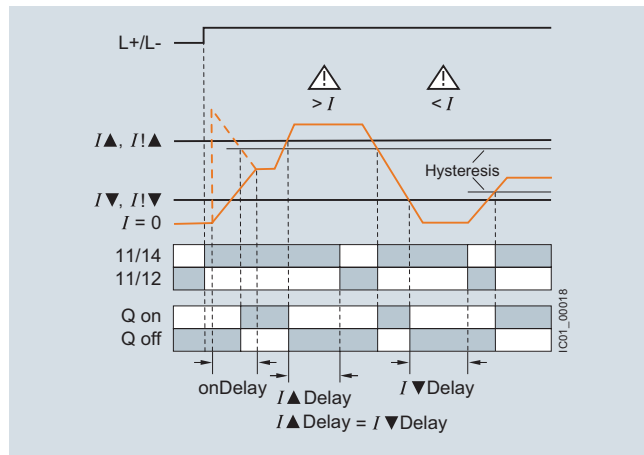

Type	3UG4822	
General technical specifications		
Rated insulation voltage U_i	V	690
Pollution degree 2 Overvoltage category III acc. to VDE 0110		
Rated impulse withstand voltage U_{imp}	kV	6
Measuring circuit		
Measuring range single-phase AC/DC current	A	0.05 ... 15
Setting range for single-phase current	A	0.05 ... 10
Load supply voltage	V	Max. 300 (with protective separation) Max. 500 (with simple separation)
Control circuit		
Load capacity of the output relay		
• Conventional thermal current I_{th}	A	5
Rated operational current I_e at		
• AC-15/24 ... 400 V	A	3
• DC-13 at		
- 24 V	A	1
- 125 V	A	0.2
- 250 V	A	0.1
Minimum contact load at 17 V DC	mA	5

Circuit diagram

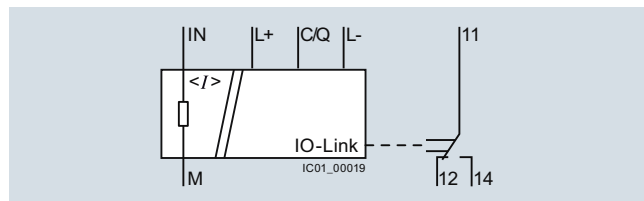

3UG4822

Note:

It is not necessary to protect the measuring circuit for device protection. The protective device for line protection depends on the cross-section used.

NEW SIRIUS 3UG48 Monitoring Relays for Stand-Alone Installation for IO-Link

Current monitoring

Selection and ordering data

- Adjustable via IO-Link and locally, with illuminated LCD
- Power supply with 24 V DC via IO-Link or external auxiliary voltage
- Adjustable converter factor to display the measured primary current when an external current transformer is used
- Auto or Manual RESET
- Open or closed-circuit principle
- 1 CO contact, 1 semiconductor output (in SIO mode)

PU (UNIT, SET, M) = 1
 PS* = 1 unit
 PG = 41H



3UG4822-1AA40



3UG4822-2AA40

Measuring range	Adjustable hysteresis	ON-delay time adjustable onDel	Tripping delay time separately adjustable I▲Del/I▼Del	DT	Screw terminals	DT	Spring-type terminals	
AC/DC A	A	s	s		Article No.	Price per PU	Article No.	Price per PU
Monitoring of current for overshooting and undershooting								
0.05 ... 10	0.01 ... 5	0.1 ... 999.9	0.1 ... 999.9	A	3UG4822-1AA40	A	3UG4822-2AA40	

For accessories, see page 10/156.

For AC currents $I > 10$ A it is possible to use commercially available current transformers, e.g. the Siemens 4NC current transformer, as accessories, see Catalog LV 10, "Low-Voltage Power Distribution and Electrical Installation Technology".

Relays

SIRIUS 3UG48 Monitoring Relays for Stand-Alone Installation for IO-Link **NEW**

Power factor and active current monitoring

Overview



SIRIUS 3UG4841 monitoring relay

The 3UG4841 power factor and active current monitoring devices enable the load monitoring of motors.

Whereas power factor monitoring is used above all for monitoring no-load operation, the active current monitoring option can be used to observe and evaluate the load factor over the entire torque range.

Benefits

- Monitoring of even small single-phase motors with a no-load supply current below 0.5 A
- Simple determination of threshold values by the direct collection of measured variables on motor loading
- Range monitoring and active current measurement enable detection of cable breaks between control cabinets and motors, as well as phase failures
- Power factor and/or I_{res} (active current) can be selected as the measurement principle
- Width 22.5 mm
- Display and transmission of actual value and status messages to controller
- All versions with removable terminals
- All versions with screw or spring-type terminals

Application

- No-load monitoring and load shedding, such as in the event of a V-belt tear
- Underload monitoring in the low performance range, e.g. in the event of pump no-load operation
- Monitoring of overload, e.g. due to a dirty filter system
- Power factor monitoring in networks for control of compensation equipment
- Broken cable between control cabinet and motor

Technical specifications

3UG4841 monitoring relays

The 3UG4841 monitoring relays are supplied with power through IO-Link or with an external auxiliary voltage of 24 V DC and are used for performing overshoot, undershoot or range monitoring of the power factor and/or the resulting active current, depending on parameterization. The load to be monitored is connected upstream of the IN terminal. The load current flows through the terminals IN and Ly/N. The setting range for the power factor is 0 to 0.99 and for the active current I_{res} 0.2 to 10 A. If the control supply voltage is switched on and no load current flows, the display will show $I < 0.2$ and a symbol for overrange, underrange or range monitoring. If the motor is now switched on and the current exceeds 0.2 A, the set ON-delay time onDel begins. During this time, if the set limit values are undershot or exceeded, this does not lead to a relay reaction of the change-over contact. If the operational flowing active current and/or the p.f. value falls below or exceeds the respective set threshold value, the tripping delay time begins. When this time has expired, the relay changes its switch position. The relevant measured variables for overshooting and undershooting in the display flash. If the monitoring of active current undershooting is deactivated ($I_{res} \nabla = OFF$) and the load current drops below the lower measuring range threshold (0.2 A), then the CO contacts remain unchanged. If a threshold value is set for the monitoring of active current undershooting, then undershooting of the measuring range threshold (0.2 A) will result in a response of the CO contacts.

The relay operates either according to the open-circuit or closed-circuit principle.

If the device is set to Auto RESET (Memory = No), depending on the set principle of operation, the switching relay returns to its initial state and the flashing ends when the hysteresis threshold is reached.

If Manual RESET is selected in the menu (Memory = Yes), the switching relay remains in its current switching state and the current measured value and the symbol for undershooting and overshooting continues to flash, even when the measured variable reaches a permissible value again. This stored fault status can be reset by simultaneously pressing the UP▲ or DOWN▼ key for 2.5 s.

With Manual RESET through IO-Link it is possible in addition to set whether error signals are to be deleted when the control supply voltage is switched off and on (as remote RESET) or whether the signals are to be permanently saved even in a voltage failure, with confirmation possible only through local RESET or via IO-Link.

NEW SIRIUS 3UG48 Monitoring Relays for Stand-Alone Installation for IO-Link

Power factor and active current monitoring

With the closed-circuit principle selected

Response in the event of undershooting the measuring range limit

- With activated monitoring of I_{res} ▼

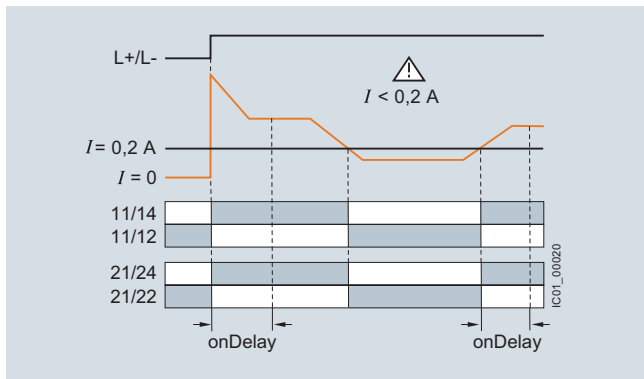

- With deactivated monitoring of active current undershooting

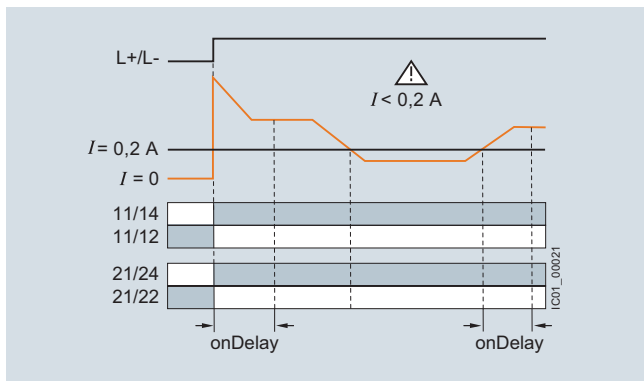

Overshooting of active current

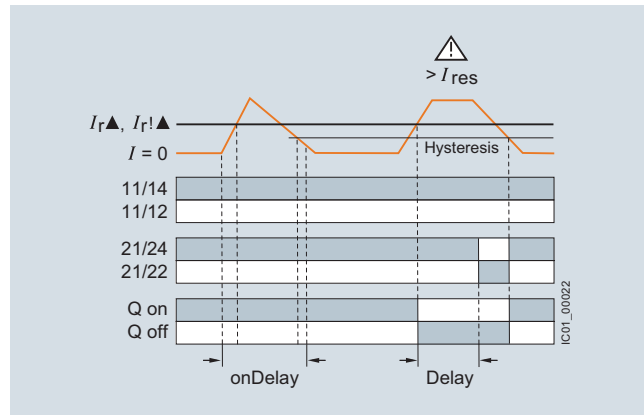

Undershooting of active current

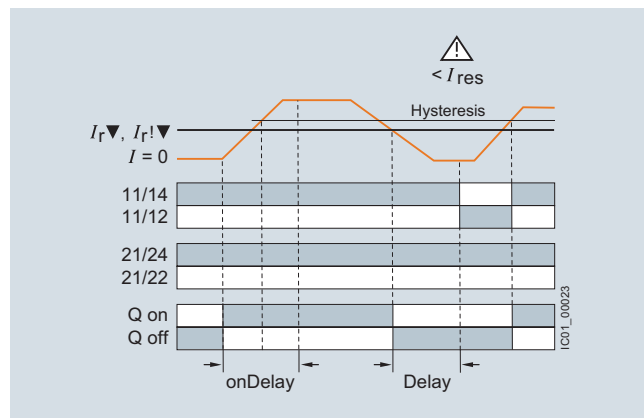

Range monitoring of active current

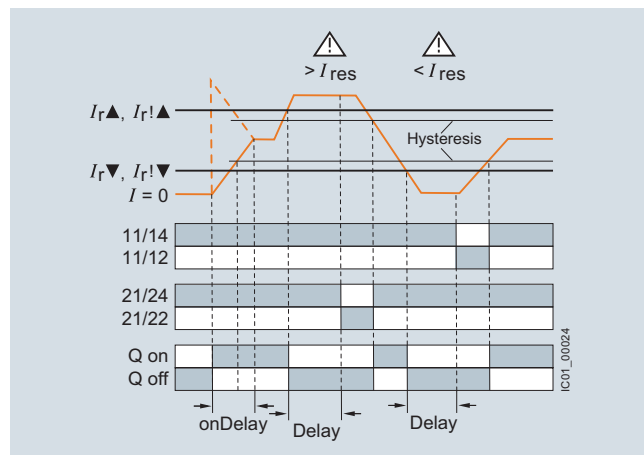

Relays

SIRIUS 3UG48 Monitoring Relays for Stand-Alone Installation for IO-Link NEW

Power factor and active current monitoring

With the closed-circuit principle selected

Overshooting of power factor

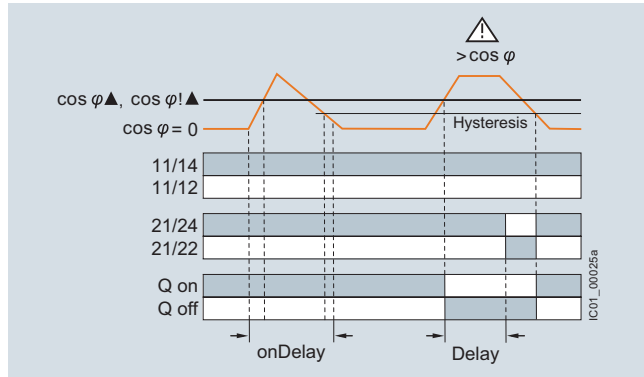

Range monitoring of power factor

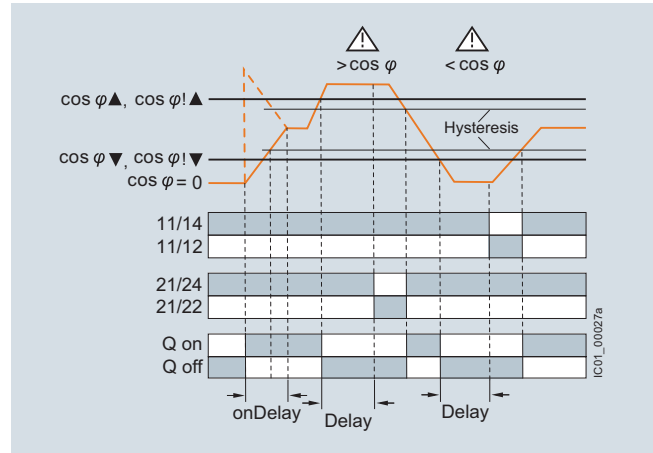

Undershooting of power factor

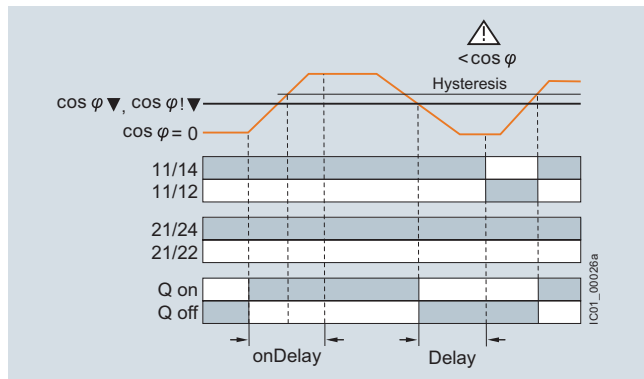

Type	3UG4841	
General technical specifications		
Rated insulation voltage U_i	V	690
Pollution degree 2 Overvoltage category III according to IEC 60664-1		
Rated impulse withstand voltage U_{imp}	kV	6
Control circuit		
Number of CO contacts for auxiliary contacts		2
Load capacity of the output relay		
• Conventional thermal current I_{th}	A	5
Rated operational current I_e at		
• AC-15/24 ... 400 V	A	3
• DC-13 at		
- 24 V	A	1
- 125 V	A	0.2
- 250 V	A	0.1
Minimum contact load at 17 V DC	mA	5

Circuit diagram

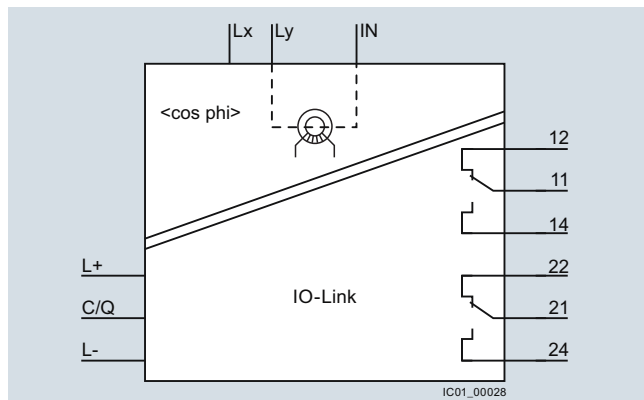

3UG4841

Note:

It is not necessary to protect the measuring circuit for device protection. The protective device for line protection depends on the cross-section used.

NEW SIRIUS 3UG48 Monitoring Relays for Stand-Alone Installation for IO-Link

Power factor and active current monitoring

Selection and ordering data

- For monitoring the power factor and the active current I_{res} (p.f. x I)
- Suitable for single- and three-phase currents
- Adjustable via IO-Link and locally, with illuminated LCD
- Power supply with 24 V DC via IO-Link or external auxiliary voltage
- Overshoot, undershoot or range monitoring adjustable
- Upper and lower limit values can be adjusted separately
- Permanent display of actual value and tripping state
- 1 CO contact each for undershoot and overshoot, 1 semiconductor output (in SIO mode)

PU (UNIT, SET, M) = 1
 PS* = 1 unit
 PG = 41H



3UG4841-1CA40



3UG4841-2CA40

Measuring range		Voltage range of the measuring voltage ¹⁾ 50/60 Hz AC	Hysteresis		ON-delay time adjustable onDel	Tripping delay time separately adjustable U▲Del/ U▼Del, φ▲Del/ φ▼Del	DT	Screw terminals		DT	Spring-type terminals	
For power factor	For active current I_{res}		Adjustable for power factor	Adjustable for active current I_{res}				Article No.	Price per PU		Article No.	Price per PU
P.f.	A	V	P.f.	A	s	s						

Monitoring of power factor and active current for overshooting and undershooting						
0.1 ... 0.99	0.2 ... 10	90 ... 690	0.1 ... 0.2	0.1 ... 3	0 ... 999.9	0 ... 999.9 A

3UG4841-1CA40	A	3UG4841-2CA40
----------------------	---	----------------------

¹⁾ Absolute limit values.

For accessories, see page 10/156.

For AC active currents $I_{res} > 10$ A it is possible to use commercially available current transformers, e.g. Siemens 4NC current converter, as accessories, see Catalog LV 10 "Low-Voltage Power Distribution and Electrical Installation Technology".

Relays

SIRIUS 3UG48 Monitoring Relays for Stand-Alone Installation for IO-Link NEW

Residual-current monitoring relays

Overview



SIRIUS 3UG4825 monitoring relay

The 3UG4825 residual-current monitoring relays are used in conjunction with the 3UL23 residual current transformers for monitoring plants in which higher residual currents are increasingly expected due to ambient conditions. Monitoring encompasses pure AC residual currents or AC residual currents with a pulsating DC fault current component (transformer type A in accordance with DIN VDE 0100-530/IEC TR 60755).

Benefits

- High measuring accuracy $\pm 7.5\%$
- Permanent self-monitoring
- Parameterization of the devices locally or via IO-Link possible
- Variable threshold values for warning and disconnection
- Freely configurable delay times and RESET response
- Display and transmission of actual value and status messages to controller
- High level of flexibility and space saving through installation of the transformer inside or outside the control cabinet
- Width 22.5 mm
- All versions with removable terminals
- All versions with screw or spring-type terminals

Application

Monitoring of plants in which residual currents can occur, e.g. due to dust deposits or moisture, porous cables and leads, or capacitive residual currents.

Technical specifications

3UG4825 monitoring relays

The main conductor, and any neutral conductor to which a load is connected, are routed through the opening of the annular ring core of a residual-current transformer. A secondary winding is placed around this annular strip-wound core to which the monitoring relay is connected.

If operation of a plant is fault-free, the sum of the inflowing and outward currents equals zero. No current is then induced in the secondary winding of the residual-current transformer.

However, if an insulation fault occurs downstream of the residual current operated motor starter protector, the sum of the inflowing currents is greater than that of the outward currents. The differential current – the residual current – induces a secondary current in the secondary winding of the transformer. This current is evaluated in the monitoring relay and is used on the one hand to display the actual residual current and on the other, to switch the relay if the set warning or tripping threshold is overshoot.

If the measured residual current exceeds the set warning value, the associated changeover contact instantly changes the switching state and an indication appears on the display.

If the measured residual current exceeds the set tripping value, the set delay time begins and the associated relay symbol flashes. On expiry of this time, the associated changeover contact changes the switching state.

ON-delay time for motor start

To be able to start a drive when a residual current is detected, the output relays switch to the OK state for an adjustable ON-delay time depending on the selected open-circuit principle or closed-circuit principle.

The changeover contacts do not react if the set threshold values are overshoot during this period.

With the closed-circuit principle selected

Residual current monitoring with Auto RESET (Memory = no)

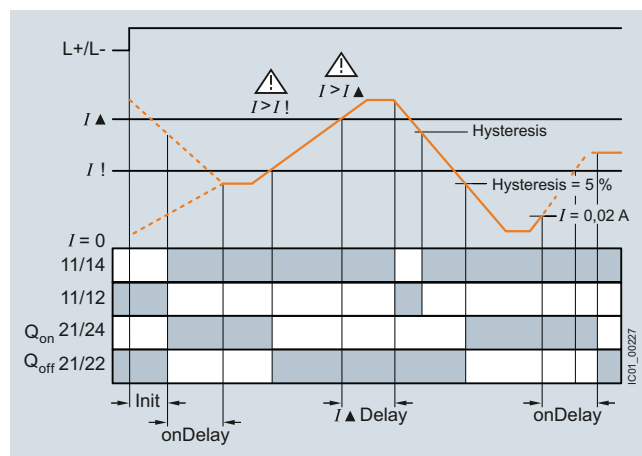

If the device is set to Auto RESET, the relay switches back to the OK state for the tripping value once the value falls below the set hysteresis threshold and the display stops flashing.

The associated relay changes its switching state if the value falls below the fixed hysteresis value of 5% of the warning value.

Any overshoots are therefore not stored.

NEW SIRIUS 3UG48 Monitoring Relays for Stand-Alone Installation for IO-Link Residual Current Monitoring

Residual-current monitoring relays

Residual current monitoring with Manual RESET (Memory = yes)

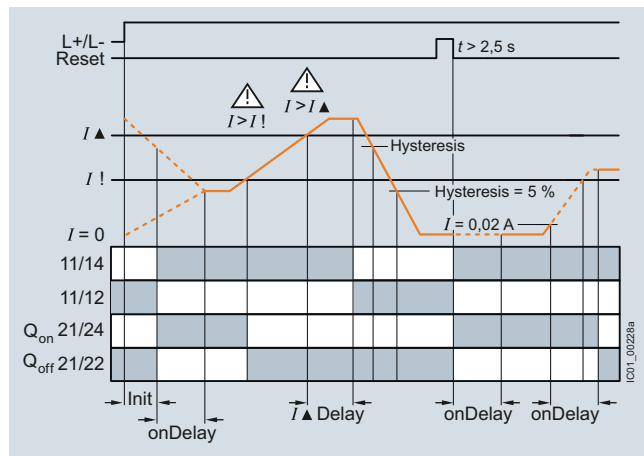

If Manual RESET is selected in the menu, the output relays remain in their current switching state and the current measured value and the symbol for overshooting continues to flash, even when the measured residual current returns to a permissible value. This stored fault status can be reset by pressing the UP▲ or DOWN▼ key simultaneously for > 2 seconds, or by switching the supply voltage off and back on again.

Note:

The neutral conductor must not be grounded downstream of the summation current transformer as this may impair the function of the residual current monitoring device.

Type	3UG4825-1CA40, 3UG4825-2CA40	
General data		
Insulation voltage for overvoltage category III to IEC 60664 for pollution degree 3 rated value	V	300
Impulse withstand voltage rated value U_{imp}	kV	4
Control circuit		
Number of CO contacts for auxiliary contacts		2
Thermal current of the non-solid-state contact blocks maximum	A	5
Current carrying capacity of the output relay		
• At AC-15 at 250 V at 50/60 Hz	A	3
• At DC-13		
- At 24 V	A	1
- At 125 V	A	0.2
- At 250 V	A	0.1
Operational current at 17 V minimum	mA	5

Circuit diagram

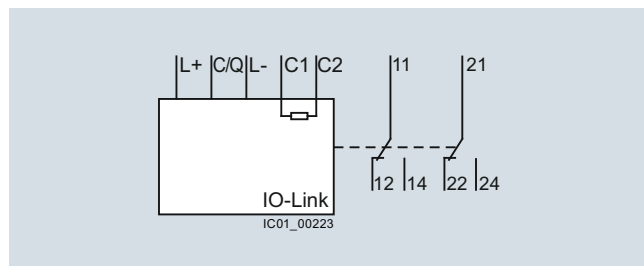

3UG4825

Note:

It is not necessary to protect the measuring circuit for device protection. The protective device for line protection depends on the cross-section used.

Relays

SIRIUS 3UG48 Monitoring Relays for Stand-Alone Installation for IO-Link Residual Current Monitoring

NEW

Residual-current monitoring relays

Selection and ordering data

- For monitoring residual currents from 0.03 to 40 A, from 16 to 400 Hz
- For 3UL23 residual-current transformers with feed-through opening from 35 to 210 mm
- Permanent self-monitoring
- Certified in accordance with IEC 60947, functionality corresponds to IEC 62020
- Digitally adjustable, with illuminated LCD
- Permanent display of actual value and tripping state
- Separately adjustable limit value and warning threshold
- 1 changeover contact each for warning threshold and tripping threshold



PU (UNIT, SET, M) = 1
 PS* = 1 unit
 PG = 41H



3UG4825-1CA40



3UG4825-2CA40

Measurable current	Adjustable response value current	Switching hysteresis	Adjustable ON-delay time	Control supply voltage At DC rated value	DT	Screw terminals 		Spring-type terminals 	
						Article No.	Price per PU	Article No.	Price per PU
A	A	%	s	V					
0.01 ... 43	0.03 ... 40	0 ... 50	0 ... 999.9	24	A	3UG4825-1CA40	A	3UG4825-2CA40	

For accessories, see page 10/156.

3UL23 residual-current transformers and accessories for 3UL23, see page 10/114.

Overview

SIRIUS 3UG4851 monitoring relay

3UG4851 monitoring relays are used in combination with a sensor to monitor drives for overspeed and/or underspeed.

Furthermore, the monitoring relays are ideal for all functions where a continuous pulse signal needs to be monitored (e.g. belt travel monitoring, completeness monitoring, passing monitoring, clock-time monitoring).

Benefits

- Variably adjustable to overshoot, undershoot or range monitoring
- Freely configurable delay times and RESET response
- Display and transmission of actual value and fault type to controller
- Use of up to 10 sensors per rotation for extremely slowly rotating motors
- 2- or 3-wire sensors and sensors with a mechanical switching output or semiconductor output can be connected
- Auxiliary voltage for sensor integrated
- All versions with removable terminals
- All versions with screw or spring-type terminals

Application

- Slip or tear of a belt drive
- Overload monitoring
- Transport monitoring for completeness

Technical specifications**3UG4851 monitoring relays**

The speed monitoring relay operates according to the principle of period duration measurement.

In the monitoring relay, the time between two successive rising edges of the pulse encoder is measured and compared to the minimum and/or maximum permissible period duration calculated from the set limit values for the speed.

Thus, the period duration measurement recognizes any deviation in speed after just two pulses, even at very low speeds or in the case of extended pulse gaps.

By using up to ten pulse encoders evenly distributed around the circumference, it is possible to shorten the period duration, and in turn the response time. By taking into account the number of sensors in the monitoring relay, the speed continues to be indicated in rpm.

ON-delay time for motor start

To be able to start a motor drive, and depending on whether the open-circuit or closed-circuit principle is selected, the output relay switches to the GO state during the ON-delay time, even if the speed is still below the set value.

The ON-delay time is started by either switching on the auxiliary voltage or, if the auxiliary voltage is already applied, by actuating the respective NC contact (e.g. auxiliary contact).

Speed monitoring with Auto RESET (Memory = no)

If the device is set to Auto RESET, the output relay switches to the GO state, once the adjustable hysteresis threshold is reached in the range of 1 ... 99.9 rpm and the flashing stops. Any overshoots or undershoots are therefore not stored.

Speed monitoring with Manual RESET (Memory = yes)

If Manual RESET is selected in the menu, the output relay remains in its current switching state and the current measured value and the symbol for overshooting/undershooting continue to flash, even when the speed returns to a permissible value. This stored fault status can be reset by simultaneously pressing the UP▲ or DOWN▼ key for > 2.5 s or by connecting the RESET device terminal to 24 V DC.

With Manual RESET through IO-Link it is possible in addition to set whether error signals are to be deleted when the control supply voltage is switched off and on (as remote RESET) or whether the signals are to be permanently saved even in a voltage failure, with confirmation possible only through local RESET or via IO-Link.

Relays

SIRIUS 3UG48 Monitoring Relays for Stand-Alone Installation for IO-Link **NEW**

Speed monitoring

With the closed-circuit principle selected

Range monitoring without enable input

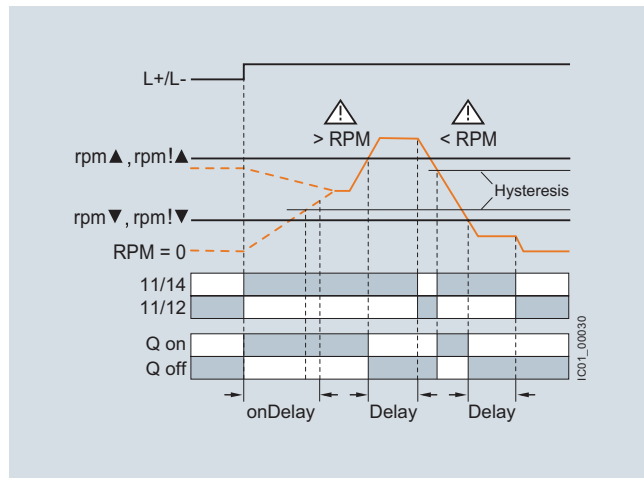

Range monitoring with enable input

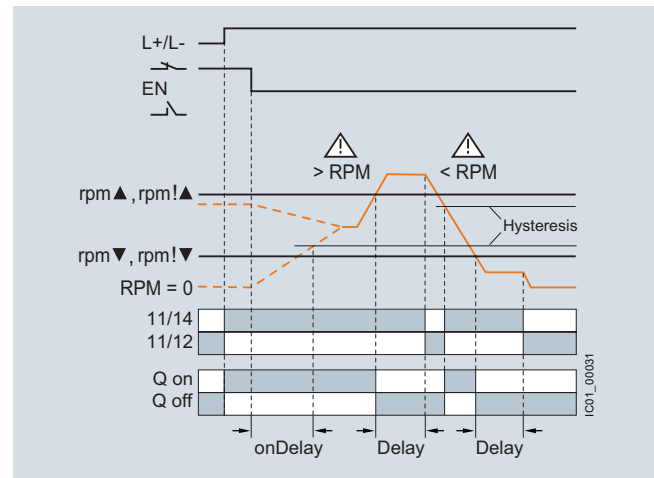

Type	3UG4851	
General technical specifications		
Rated insulation voltage U_i Pollution degree 2 Overvoltage category III acc. to VDE 0110	V	300
Rated impulse withstand voltage U_{imp}	kV	4
Measuring circuit		
Sensor supply		
• For three-wire sensor (24 V/0 V)	mA	Max. 50
• For 2-wire NAMUR sensor (8V2)	mA	Max. 8.2
Signal input		
• IN1	k Ω	16, three-wire sensor, pnp operation
• IN2	k Ω	1, floating contact, 2-wire NAMUR sensor
Voltage level		
• For level 1 at IN1	V	4.5 ... 30
• For level 0 at IN1	V	0 ... 1
Current level		
• For level 1 at IN2	mA	> 2.1
• For level 0 at IN2	mA	< 1.2
Minimum pulse duration of signal	ms	5
Minimum interval between 2 pulses	ms	5
Control circuit		
Number of CO contacts for auxiliary contacts		1
Load capacity of the output relay Conventional thermal current I_{th}	A	5
Rated operational current I_o at		
• AC-15/24 ... 250 V	A	3
• DC-13 at		
- 24 V	A	1
- 125 V	A	0.2
- 250 V	A	0.1
Minimum contact load at 17 V DC	mA	5

Circuit diagram

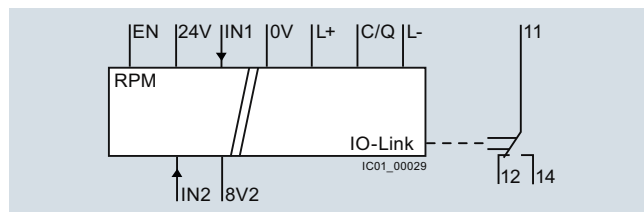

3UG4851

Note:

It is not necessary to protect the measuring circuit for device protection. The protective device for line protection depends on the cross-section used.

NEW SIRIUS 3UG48 Monitoring Relays for Stand-Alone Installation for IO-Link

Speed monitoring

Selection and ordering data

- For speed monitoring in revolutions per minute (rpm)
- Two- or three-wire sensor with mechanical or electronic switching output can be connected
- Two-wire NAMUR sensor can be connected
- Sensor supply 24 V DC/50 mA integrated
- Input frequency 0.1 to 2 200 pulses per minute (0.0017 to 36.7 Hz)
- With or without enable signal for the drive to be monitored
- Adjustable via IO-Link and locally, with illuminated LCD
- Power supply with 24 V DC via IO-Link or external auxiliary voltage
- Overshoot, undershoot or range monitoring adjustable
- Number of pulses per revolution can be adjusted
- Upper and lower limit values can be adjusted separately
- Auto, manual or remote RESET options after tripping
- Permanent display of actual value and tripping state
- 1 CO contact, 1 semiconductor output (in SIO mode)

PU (UNIT, SET, M) = 1
 PS* = 1 unit
 PG = 41H



3UG4851-1AA40



3UG4851-2AA40

Measuring range	Adjustable hysteresis	ON-delay time adjustable onDel	Tripping delay time separately adjustable rpm▲Del/rpm▼Del	Pulses per revolution	DT	Screw terminals	DT	Spring-type terminals	
rpm	rpm	s	s			Article No.	Price per PU	Article No.	Price per PU
Speed monitoring for overshooting and undershooting									
0.1 ... 2 200	OFF 1 ... 99.9	0 ... 999.9	0 ... 999.9	1 ... 10	A	3UG4851-1AA40	A	3UG4851-2AA40	

For accessories, see page 10/156.



Relays

SIRIUS 3UG48 Monitoring Relays for Stand-Alone Installation for IO-Link

NEW

Accessories

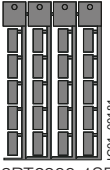
Selection and ordering data

Use	Version	DT	Article No.	Price per PU	PU (UNIT, SET, M)	PS*	PG	
Blank labels								
 3RT2900-1SB20	For 3UG48							
		Unit labeling plates For SIRIUS devices 20 mm x 7 mm, titanium gray ¹⁾	D	3RT2900-1SB20		100	340 units	41B
	For 3UG48	Adhesive labels For SIRIUS devices						
			• 19 mm x 6 mm, pastel turquoise	C	3RT1900-1SB60	100	3 060 units	41B
			• 19 mm x 6 mm, zinc yellow	C	3RT1900-1SD60	100	3 060 units	41B
Push-in lugs and covers								
 3RP1903 3RP1902	For 3UG48							
		Push-in lugs For screw fixing, 2 units are required for each device	B	3RP1903		1	10 units	41H
	For 3UG48							
			Sealable covers For securing against unauthorized adjustment of setting knobs	B	3RP1902	1	5 units	41H
Tools for opening spring-type terminals								
 3RA2908-1A	For auxiliary circuit connections							
		Screwdrivers For all SIRIUS devices with spring-type terminals 3.0 mm x 0.5 mm, length approx. 200 mm, titanium gray/black, partially insulated	A	3RA2908-1A		1	1 unit	41B
			Spring-type terminals					

¹⁾ PC labeling system for individual inscription of unit labeling plates available from: murrplastik Systemtechnik GmbH, see Chapter 16, "Appendix" → "External Partners".

Overview

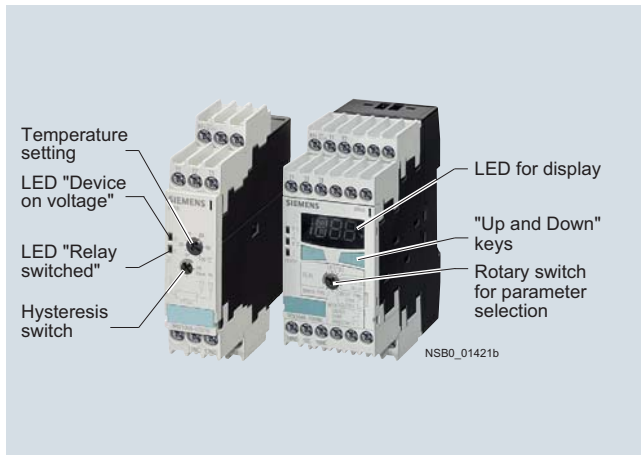

SIRIUS 3RS temperature monitoring relay

The 3RS10, 3RS11, 3RS20 and 3RS21 temperature monitoring relays can be used for measuring temperatures in solid, liquid and gas media. The temperatures are acquired by means of sensors in the medium, evaluated by the device and monitored for overshoot, undershoot or location within a specified range (window function).

The range comprises adjustable analog units with one or two threshold values, digital units for 1 sensor, which are also a good alternative to temperature controllers for the low-end range, and digital units for up to 3 sensors which have been optimized for monitoring large motors.

Article No. scheme

Digit of the Article No.	1st - 3rd	4th	5th	6th	7th	8th	9th	10th	11th	12th
	□□□	□	□	□	□	-	□	□	□	□
Temperature monitoring relays	3 R S									
Device type		□	□							
Version and type of sensor				□	□					
Connection methods							□			
Number and type of outputs								□		
Control supply voltage									□	
Measuring range										□
Special versions										□
Example	3 R S	1	0	0	0	-	1	C	D	0 0

Note:

The Article No. scheme is presented here merely for information purposes and for better understanding of the logic behind the article numbers.

For your orders, please use the article numbers quoted in the catalog in the Selection and ordering data.

Benefits

Advantages through energy efficiency

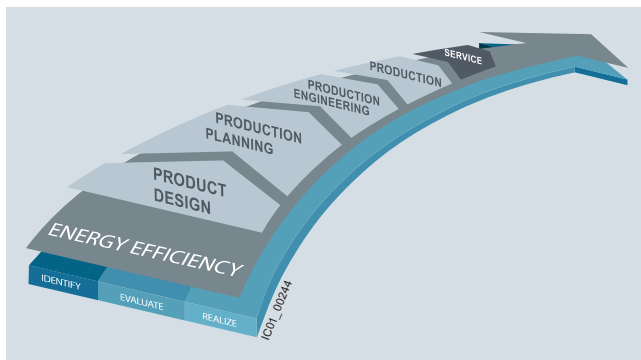

Overview of the energy management process

We offer you a unique portfolio for industrial energy management, using an energy management system that helps to optimally define your energy needs. We split up our industrial energy management into three phases – identify, evaluate, and realize – and we support you with the appropriate hardware and software solutions in every process phase.

The innovative SIRIUS industrial controls products can also make a major contribution to the energy efficiency of a plant (www.siemens.com/sirius/energysaving).

The 3RS10, 3RS11, 3RS20 and 3RS21 temperature monitoring relays make the following contribution to the energy efficiency of the plant as a whole:

- Demand-based control of heating and ventilation in the process and in the control cabinet

Relays

SIRIUS 3RS10, 3RS11, 3RS20, 3RS21 Temperature Monitoring Relays

General data

Technical specifications

Connection of resistance-type thermometers

Two-wire measurement

When two-wire temperature sensors are used, the resistances of the sensor and wiring are added. The resulting systematic error must be taken into account when the signal evaluation unit is calibrated. A jumper must be clamped between terminals T2 and T3 for this purpose.

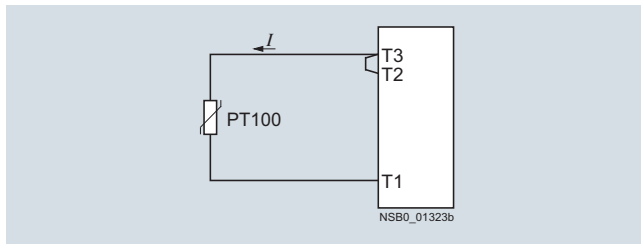

Wiring errors

The errors that are generated by the wiring comprise approximately 2.5 K/Ω. If the resistance of the cable is not known and cannot be measured, the wiring errors can also be estimated using the following table.

Temperature drift dependent on the length and cross-section of the cable with PT100 sensors and an ambient temperature of 20 °C, in K:

Cable length in m	Cross-section mm ²			
	0.5	0.75	1	1.5
	Temperature drift in K:			
0	0	0	0	0
10	1.8	1.2	0.9	0.6
25	4.5	3.0	2.3	1.5
50	9.0	6.0	4.5	3.0
75	13.6	9.0	6.8	4.5
100	18.1	12.1	9.0	6.0
200	36.3	24.2	18.1	12.1
500	91.6	60.8	45.5	30.2

Example: On a PT100 sensor with a cable length of 10 m and a conductor cross-section of 1 mm² the temperature drift equals 0.9 K.

Three-wire measurement

To minimize the effects of the line resistances, a three-wire circuit is often used. Using the additional cable, two measuring circuits can be formed of which one is used as a reference. The signal evaluation unit can then automatically calculate the line resistance and take it into account.

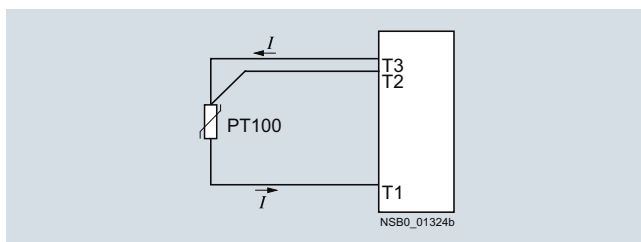

Connection of thermocouples

Based on the thermo-electrical effect, a differential temperature measurement will be performed between the measuring point and the signal evaluation unit.

This principle assumes that the signal evaluation unit knows the temperature at the clamping point (T2). For this reason, the 3RS11 temperature monitoring relay has an integral compensator that determines this comparison temperature and builds it into the result of the measurement. The thermal sensors and cables must be insulated therefore.

The absolute temperature is therefore calculated from the ambient temperature of the signal evaluation unit and the temperature difference measured by the thermoelement.

Temperature detection is therefore possible (T1) without needing to know the precise ambient temperature of the clamping point at the signal evaluation unit (T2).

The connecting cable is only permitted to be extended using connecting leads that are made from the same material as the thermocouple. If a different type of conductor is used, an error will result in the measurement.

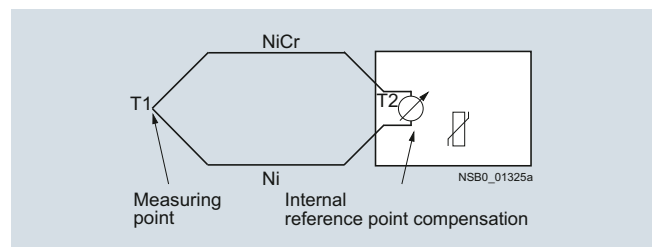

For more information, see

www.feldgeraete.de/76/produkte/fuw.html

www.ephy-mess.de

or from

EPHY-MESS GmbH, see Chapter 16 "Appendix"
→ "External Partners"

Principle of operation

Once the temperature has reached the set threshold value ϑ_1 , the output relay K1 changes its switching state as soon as the set time t has elapsed (K2 responds in the same manner to ϑ_2). The delay time can only be adjusted with digital units (on analog units $t = 0$).

The relays return to their original state as soon as the temperature reaches the set hysteresis value.

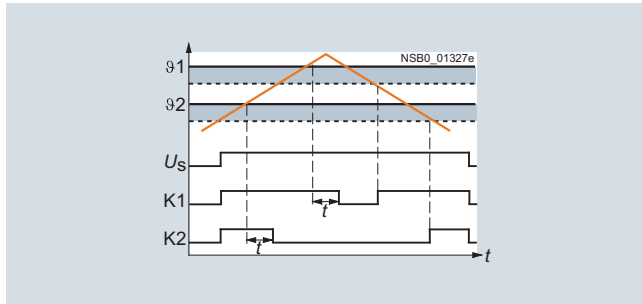
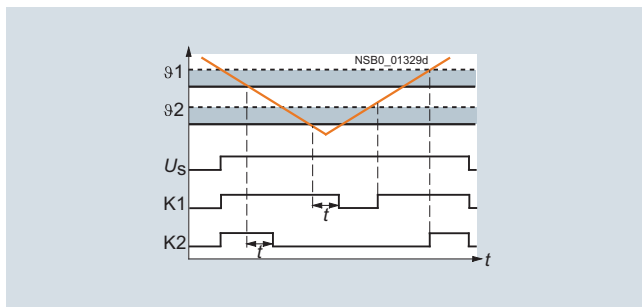
Temperature overshootClosed-circuit principle**Temperature undershoot**Closed-circuit principle**Range monitoring (digital units only)**

Once the temperature has reached the upper threshold value ϑ_1 , the output relay K1 changes its switching state as soon as the set time t has elapsed. The relay returns to its original state as soon as the temperature reaches the set hysteresis value.

K2 responds in the same manner to the lower threshold value of ϑ_2 .

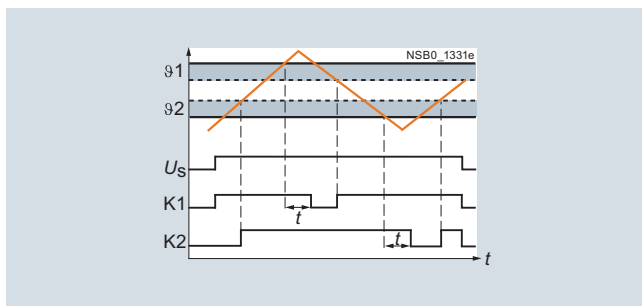
Closed-circuit principle**Principle of operation with memory function (3RS1042, 3RS1142) based on the example of temperature overshoot**

Once the temperature has reached the set threshold value ϑ_1 , the output relay K1 changes its switching state as soon as the set time t has elapsed (K2 responds in the same manner to ϑ_2). The relays only return to the original state when the temperature falls below the set hysteresis value and when terminals Y3 and Y4 have been briefly jumpered.

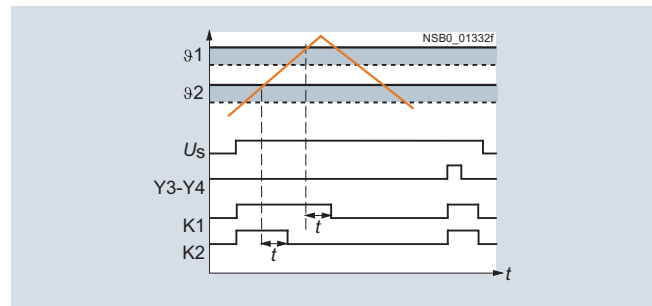
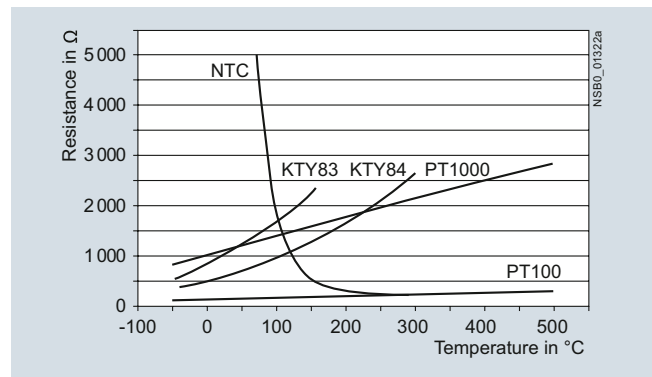
Closed-circuit principle**Characteristic curves**For resistance sensors

The short-circuit and open-circuit detection as well as the measuring range is limited, depending on the sensor type.

Measuring ranges in °C for resistance sensors

Sensor type	Short circuit	Open circuit	3RS1040/ 3RS1041 Measuring range in °C	3RS1042 Measuring range in °C
PT100	✓	✓	-50 ... +500	-50 ... +750
PT1000	✓	✓	-50 ... +500	-50 ... +500
KTY83-110	✓	✓	-50 ... +175	-50 ... +175
KTY84	✓	✓	-40 ... +300	-40 ... +300
NTC ¹⁾	✓	--	80 ... 160	80 ... 160

✓ Detection possible

-- Detection not possible

¹⁾ NTC type: B57227-K333-A1 (100 °C: 1.8 kΩ; 25 °C: 32.762 kΩ).

Relays

SIRIUS 3RS10, 3RS11, 3RS20, 3RS21 Temperature Monitoring Relays

General data

Characteristic curves

For thermocouples

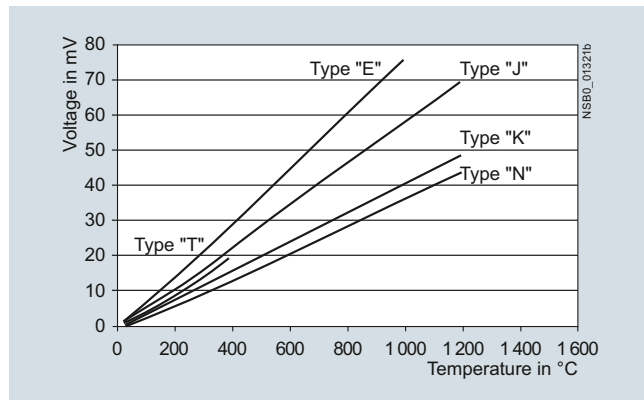

Characteristic curves for sensor types J, K, T, E, N

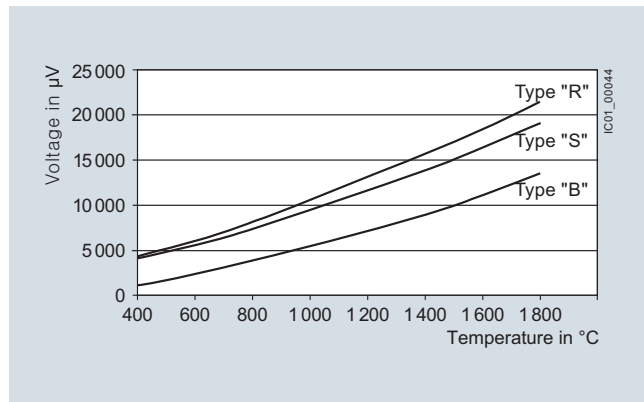

Characteristic curves for sensor types S, R and B

Measuring range in °C for thermocouples

Sensor type	Short circuit	Open circuit	3RS1140 Measuring range in °C	3RS1142 Measuring range in °C
J	--	✓	-99 ... +999	-99 ... +1200
K	--	✓	-99 ... +999	-99 ... +1350
T	--	✓	-99 ... +400	-99 ... +400
E	--	✓	-99 ... +999	-99 ... +999
N	--	✓	-99 ... +999	-99 ... +999
S	--	✓	--	0 ... 1750
R	--	✓	--	0 ... 1750
B	--	✓	--	400 ... 1800

✓ Detection possible

-- Detection not possible

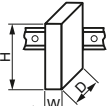
Type		3RS10, 3RS11 analog	3RS10, 3RS11, 3RS20, 3RS21 digital
General technical specifications			
Dimensions (W x H x D)			
• Screw terminals		mm 22.5 x 102 x 91	45 x 106 x 91
• Spring-type terminals		mm 22.5 x 103 x 91	45 x 108 x 91
Permissible ambient temperature			
• During operation		°C -25 ... +60	
Connection type		⊕ Screw terminals	
• Terminal screw		M3 (for standard screwdriver, size 2 and Pozidriv 2)	
• Solid	mm ²	1 x (0.5 ... 4)/2 x (0.5 ... 2.5)	
• Finely stranded with end sleeve	mm ²	1 x (0.5 ... 2.5)/2 x (0.5 ... 1.5)	
• AWG cables, solid or stranded	AWG	2 x (20 ... 14)	
Connection type		⊖ Spring-type terminals	
• Solid	mm ²	2 x (0.25 ... 1.5)	
• Finely stranded, with end sleeves acc. to DIN 46228	mm ²	2 x (0.25 ... 1.5)	
• Finely stranded	mm ²	2 x (0.25 ... 1.5)	
• AWG cables, solid or stranded	AWG	2 x (24 ... 16)	

More information

For "3RS1/3RS2 Temperature Monitoring Relays" manual, see <http://support.automation.siemens.com/WW/view/en/54999309>.

Overview



SIRIUS 3RS analog temperature monitoring relays for 1 sensor

The 3RS10, 3RS11 analog temperature monitoring relays can be used for measuring temperatures in solid, liquid and gas media. The temperature is detected by the sensors in the medium, evaluated by the device and monitored for overshoot or undershoot. When the threshold values are reached, the output relay switches on or off depending on the parameterization.

Benefits

- All devices except for 24 V AC/DC feature electrical separation
- Extremely easy operation using a rotary potentiometer
- Adjustable hysteresis
- Adjustable working principle for devices with 2 threshold values
- All versions with removable terminals
- All versions with screw terminals, many versions alternatively with spring-type terminals

Application

The analogically adjustable SIRIUS 3RS10, 3RS11 temperature monitoring relays can be used in almost any application in which temperature overshoot or undershoot is not permitted, e.g. in the monitoring of set temperature limits and the output of alarm messages for:

- Motor and system protection
- Control cabinet temperature monitoring
- Freeze monitoring
- Temperature limits for process variables e.g. in the packaging industry or electroplating
- Controlling equipment and machines such as heating, climate and ventilation systems, solar collectors, heat pumps or warm water supplies
- Motor, bearing and gear oil monitoring
- Monitoring of coolants

Technical specifications

Type		3RS1000, 3RS1010	3RS1100, 3RS1101	3RS1020, 3RS1030	3RS1120, 3RS1121
Auxiliary circuit					
Rated operational currents I_b					
• AC-15/24 ... 250 V	A	3			
• DC-13 at					
- 24 V	A	1			
- 125 V	A	0.2			
- 240 V	A	0.1			
Measuring accuracy at 20 °C ambient temperature (T20)		Typically < ±5 % from upper limit of scale			
Reference point accuracy	K	--	< ±5	--	< ±5
Deviations due to ambient temperature In % of the measuring range		< 2	< 3	< 2	< 3
Hysteresis settings					
• For temperature 1	%	2 ... 20 from upper limit of scale			
• For temperature 2	%	5 from upper limit of scale			
Sensor circuit					
Typical sensor circuits					
• PT100	mA	Typically 1	--	Typically 1	--
Open-circuit detection		No			
Short-circuit detection		No			
Three-wire conductor connection¹⁾		Yes	--	Yes	--
Enclosure					
Rated insulation voltage U_i (pollution degree 3)	V	300			

¹⁾ Two-wire connection of resistance sensors with wire jumper between T2 and T3.

Relays

SIRIUS 3RS10, 3RS11, 3RS20, 3RS21 Temperature Monitoring Relays

Relays, analogically adjustable for 1 sensor

Circuit examples

3RS1000, 3RS1010

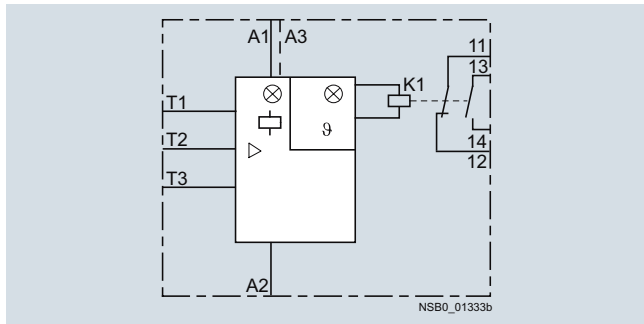

Legend

A1 = 24 V AC/DC, 230 V AC, 24 to 240 V AC/DC

A3 = 110 V AC

A2 = M

K1, K2 = Output relays

☐ = LED: "Device connected to voltage"

ø1 = LED: "Relay 1 tripped"

ø2 = LED: "Relay 2 tripped"

T1 to T3 = Sensor connection for resistance sensor

T+/T- = Sensor connection for thermocouples

⚠ Important!

When resistance sensors with two-wire connection are used, T2 and T3 must be jumpered.

3RS1020, 3RS1030

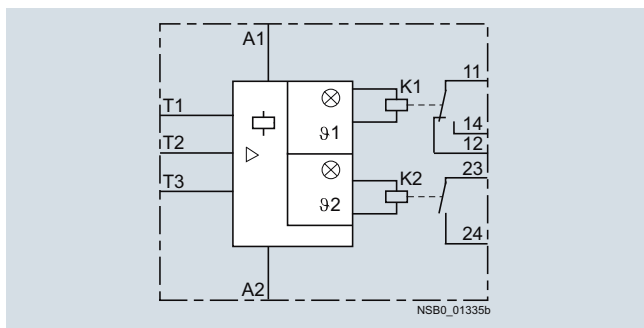

3RS1100, 3RS1101

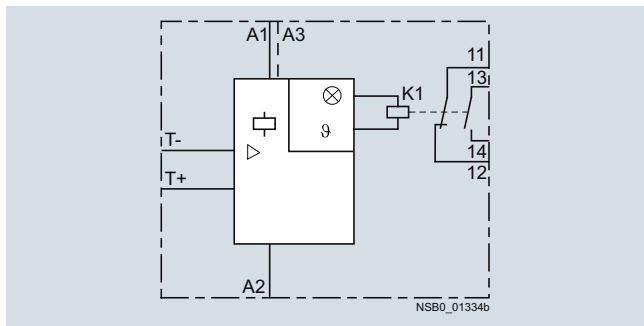

3RS1120, 3RS1121

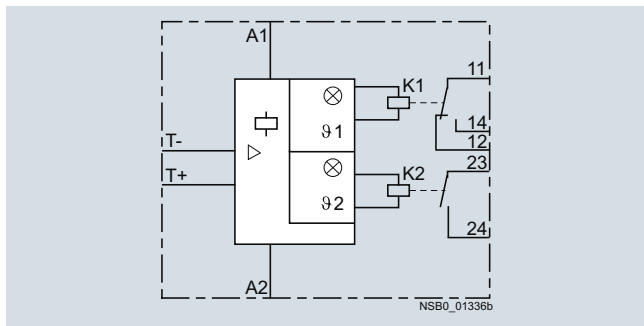

Relays

SIRIUS 3RS10, 3RS11, 3RS20, 3RS21 Temperature Monitoring Relays

Relays, digitally adjustable for 1 sensor

Overview



SIRIUS 3RS digital temperature monitoring relay for 1 sensor

The 3RS10, 3RS11, 3RS20 and 3RS21 temperature monitoring relays can be used for measuring temperatures in solid, liquid and gas media. The temperatures are acquired by means of sensors in the medium, evaluated by the device and monitored for overshoot, undershoot or location within a specified range (window function). The 3RS10 and 3RS11 unit indicate the measured temperature in °C, the 3RS20 and 3RS21 unit in °F.

The units are also an excellent alternative to temperature controllers in the low-end performance range (two-or three-point control).

Benefits

- Very simple operation without complicated menu selections
- Two- or three-point control can be parameterized quickly
- All versions with removable terminals
- All versions with screw or spring-type terminals

Application

The temperature monitoring relays can be used in almost any application in which temperature overshoot or undershoot is not permitted, e.g. in the monitoring of set temperature limits and the output of alarm messages for:

- Plant and environment protection
- Temperature limits for process variables e.g. in the packaging industry or electroplating
- Temperature limits for district heating plants
- Exhaust temperature monitoring
- Controlling equipment and machines such as heating, climate and ventilation systems, solar collectors, heat pumps or warm water supplies
- Motor, bearing and gear oil monitoring
- Monitoring of coolants

Technical specifications

Type	3RS1040, 3RS1042, 3RS2040	3RS1140, 3RS2140	3RS1142
Auxiliary circuit			
Rated operational currents I_e			
• AC-15/24 ... 250 V	A	3	
• DC-13 at:			
- 24 V	A	1	
- 125 V	A	0.2	
- 240 V	A	0.1	
Evaluation unit			
Measuring accuracy at 20 °C ambient temperature (T20)	< ± 2 K, ± 1 digit	< ± 5 K, ± 1 digit	< ± 7 K, ± 1 digit
Reference point accuracy	--	< ± 5 K	
Deviations due to ambient temperature In % of measuring range	%	0.05 °C per K deviation from T20	
Measuring cycle	ms	500	
Hysteresis settings for temperature	K	1 ... 99, for both values	
Adjustable delay time	s	0 ... 999	
Sensor circuit			
Typical sensor circuits			
• PT100	mA	Typically 1	--
• PT1000/KTY83/KTY84/NTC	mA	Typically 0.2	--
Open-circuit detection		Yes ¹⁾	Yes
Short-circuit detection		Yes	No
Three-wire conductor connection		Yes ²⁾	--
Enclosure			
Rated insulation voltage U_i (pollution degree 3)	V AC	300	

¹⁾ Not for NTC type B57227-K333-A1 (100 °C: 1.8 kΩ; 25 °C: 32.762 kΩ).

²⁾ Two-wire connection of resistance sensors with wire jumper between T2 and T3.

Circuit examples

3RS1040, 3RS1042, 3RS2040

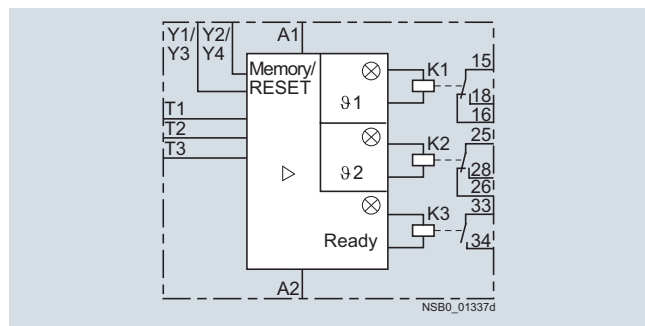

3RS1140, 3RS1142, 3RS2140

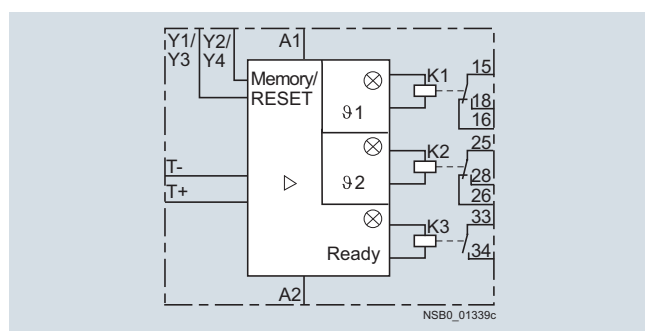
Legend

A1, A2, A3 = Terminals for rated control supply voltage

K1, K2, K3 = Output relays

ø1 = LED: "Relay 1 tripped"

ø2 = LED: "Relay 2 tripped"

Ready = LED: "Device is ready for operation"

T1 to T3 = Sensor connection for resistance sensor

T+/T- = Sensor connection for thermocouples

Y1/Y2 = Connection for memory jumper for 3RS1040, 3RS1140, 3RS2040, 3RS2140

Y3/Y4 = RESET input for 3RS1042, 3RS1142

⚠ Important!

When resistance sensors with two-wire connection are used, T2 and T3 must be jumpered.

Relays

SIRIUS 3RS10, 3RS11, 3RS20, 3RS21 Temperature Monitoring Relays

Relays, digitally adjustable for 1 sensor

Selection and ordering data

- For temperature monitoring with resistance sensors or thermocouples
- Temperature range dependent on sensor type
 - For 3RS10, 3RS11: -99 to +1 800 °C
 - For 3RS20, 3RS21: -99 to +1 830 °F
- Wide voltage range versions are electrically separated
- Non-volatile
- Short-circuit and open-circuit detection in sensor circuit
- Digitally adjustable, with illuminated LCD
- Overshoot, undershoot or range monitoring adjustable
- Exact sensor type can be set
- 2 separately adjustable threshold values
- 1 hysteresis applies to both thresholds (0 to 99 K)
- 1 delay time applies to both thresholds (0 to 999 s)
- Adjustable open/closed-circuit principle
- Adjustable manual/remote RESET
- Permanent display of actual value in °C or °F and tripping state
- 1 CO contact each per threshold value
- 1 NO for sensor monitoring

PU (UNIT, SET, M) = 1
 PS* = 1 unit
 PG = 41H

Sensors	Measuring range (measuring range limit depends on the sensor)	Rated control supply voltage U_s 50/60 Hz AC	DT	Screw terminals	DT	Spring-type terminals	
				⊕		⊕	
				Article No.	Price per PU	Article No.	Price per PU

Temperature monitoring relay, digitally adjustable, 2 threshold values, width 45 mm, 1 CO + 1 CO + 1 NO, memory function possible with external jumper, device parameters are non-volatile



3RS1040-1GD50



3RS1040-2GW50

PT100/1000; KTY83/84; NTC (resistance sensors) ¹⁾	- 50 ... + 500 °C - 58 ... + 932 °F	24 AC/DC 24 ... 240 AC/DC 24 AC/DC 24 ... 240 AC/DC	A A C C	3RS1040-1GD50 3RS1040-1GW50 3RS2040-1GD50 3RS2040-1GW50	A A C C	3RS1040-2GD50 3RS1040-2GW50 3RS2040-2GD50 3RS2040-2GW50
TYPE J, K, T, E, N (thermocouple)	- 99 ... + 999 °C - 99 ... + 1 830 °F	24 AC/DC 24 ... 240 AC/DC 24 AC/DC 24 ... 240 AC/DC	A A C C	3RS1140-1GD60 3RS1140-1GW60 3RS2140-1GD60 3RS2140-1GW60	C C C C	3RS1140-2GD60 3RS1140-2GW60 3RS2140-2GD60 3RS2140-2GW60

Temperature monitoring relay, digitally adjustable, 2 threshold values, width 45 mm; 1 CO + 1 CO + 1 NO, tripping state and device parameters are non-volatile

PT100/1000; KTY83/84; NTC (resistance sensors) ¹⁾	- 50 ... + 750 °C	24 AC/DC 24 ... 240 AC/DC	C A	3RS1042-1GD70 3RS1042-1GW70	C C	3RS1042-2GD70 3RS1042-2GW70
TYPE J, K, T, E, N, R, S, B (thermocouple)	- 99 ... + 1 800 °C	24 AC/DC 24 ... 240 AC/DC	C A	3RS1142-1GD80 3RS1142-1GW80	C C	3RS1142-2GD80 3RS1142-2GW80

¹⁾ NTC type: B57227-K333-A1 (100 °C: 1.8 kΩ; 25 °C: 32.762 kΩ).

For accessories, see page 10/169.

Overview



SIRIUS 3RS digital temperature monitoring relay for up to 3 sensors

The 3RS10, 3RS20 temperature monitoring relays can be used for measuring temperatures in solid, liquid and gas media. The temperature is detected by the sensor in the medium, evaluated by the device and monitored for overshoot or undershoot or for staying within an operating range (window function). The 3RS10 units indicate the measured temperature in °C, the 3RS20 units in °F. The evaluation unit can evaluate up to 3 resistance sensors at the same time and is specially designed for monitoring motor windings and bearings.

Benefits

- Very simple operation without complicated menu selections
- Space-saving with 45 mm width
- Two- or three-point control can be parameterized quickly
- All versions with removable terminals
- All versions with screw or spring-type terminals

Application

The 3RS10, 3RS20 temperature monitoring relays can be used in almost any application in which several temperatures have to be monitored simultaneously for overshoot or undershoot or within a range.

Monitoring of set temperature limits and output of alarm messages for:

- Plant and environment protection
- Temperature limits for process variables e.g. in the packaging industry or electroplating
- Controlling equipment and machines such as heating, climate and ventilation systems, solar collectors, heat pumps or warm water supplies
- Motor, bearing and gear oil monitoring
- Monitoring of coolants

Technical specifications

Type	3RS1041, 3RS2041	
Auxiliary circuit		
Rated operational currents I_e		
• AC-15/24 ... 250 V	A	3
• DC-13 at		
- 24 V	A	1
- 125 V	A	0.2
- 240 V	A	0.1
DIAZED fuse protection		
• Operational class gG	A	4
Evaluation unit		
Measuring accuracy at 20 °C ambient temperature (T20)		< ±2 K, ±1 digit
Deviations due to ambient temperature In % of measuring range	%	0.05 per K deviation from T20
Measuring cycle	ms	500
Hysteresis settings for temperature 1		1 ... 99 K, for both values
Adjustable delay time	s	0 ... 999
Sensor circuit		
Typical sensor circuits		
• PT100	mA	Typically 1
• PT1000/KTY83/KTY84/NTC	mA	Typically 0.2
Open-circuit detection		Yes ¹⁾
Short-circuit detection		Yes
Three-wire conductor connection		Yes ²⁾
Enclosure		
Rated insulation voltage U_i (pollution degree 3)	V AC	300

¹⁾ Not for NTC type B57227-K333-A1 (100 °C: 1.8 kΩ; 25 °C: 32.762 kΩ).

²⁾ Two-wire connection of resistance sensors with wire jumper between T2 and T3.

Relays

SIRIUS 3RS10, 3RS11, 3RS20, 3RS21 Temperature Monitoring Relays

Relays, digitally adjustable for up to 3 sensors

Circuit example

3RS1041, 3RS2041

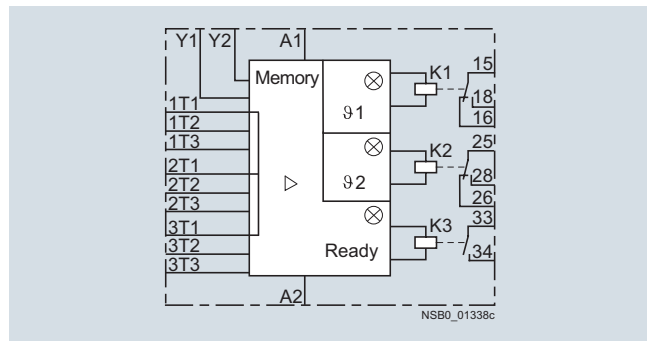

Legend

- A1, A2, A3 = Terminals for rated control supply voltage
- K1, K2, K3 = Output relays
- ø1 = LED: "Relay 1 tripped"
- ø2 = LED: "Relay 2 tripped"
- Ready = LED: "Device is ready for operation"
- 1T1 to 1T3 = Sensor connection for resistance sensor 1
- 2T1 to 2T3 = Sensor connection for resistance sensor 2
- 3T1 to 3T3 = Sensor connection for resistance sensor 3
- Y1/Y2 = Connection for memory jumper

⚠ Important!

When resistance sensors with two-wire connection are used, T2 and T3 must be jumpered.

Selection and ordering data

- For temperature monitoring of solids, liquids, and gases
- For two- and three-conductor resistance sensors or thermocouples
- Temperature range dependent of sensor type
 - For 3RS10: -50 to +500 °C
 - For 3RS20: -58 to +932 °F
- Wide voltage range versions are electrically separated
- Non-volatile
- Short-circuit and open-circuit detection in sensor circuit
- Digitally adjustable, with illuminated LCD
- Overshoot, undershoot or range monitoring adjustable
- Exact sensor type and number of sensors can be set
- 2 separately adjustable threshold values
- 1 hysteresis; applies to both thresholds (0 to 99 K)
- 1 delay time; applies to both thresholds (0 to 999 s)
- Adjustable open/closed-circuit principle
- With connectable and disconnectable error memory
- Permanent display of actual value in °C or °F and tripping state
- 1 CO contact each per threshold value
- 1 NO for sensor monitoring

PU (UNIT, SET, M) = 1
 PS* = 1 unit
 PG = 41H

Sensors	Number of sensors	Measuring range (limit of measuring range dependent on sensor)	Rated control supply voltage U_s	DT	Screw terminals	DT	Spring-type terminals	
V					Article No.	Price per PU	Article No.	Price per PU

Motor monitoring relays, digitally adjustable for up to 3 sensors, width 45 mm; 1 CO + 1 CO + 1 NO









3RS1041-1GW50

PT100/1000; KTY83/84; NTC (resistance sensors) ¹⁾	1 ... 3 sen- sors	-50 ... +500 °C -58 ... +932 °F	24 ...240 AC/DC 24 ...240 AC/DC	A C	3RS1041-1GW50	A C	3RS1041-2GW50 3RS2041-2GW50
---	-------------------------	------------------------------------	------------------------------------	--------	----------------------	--------	--

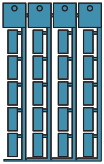
¹⁾ NTC type: B57227-K333-A1 (100 °C: 1.8 kΩ; 25 °C: 32.762 kΩ).

For accessories, see page 10/169.

Selection and ordering data

Use	Version	DT	Article No.	Price per PU	PU (UNIT, SET, M)	PS*	PG
Blank labels							
 3RT1900-1SB20	For 3RS10, 3RS11, 3RS20, 3RS21		Unit labeling plates For SIRIUS devices				
	20 mm x 7 mm, pastel turquoise ¹⁾	D	3RT1900-1SB20		100	340 units	41B
 3RP1902	For 3RS10, 3RS11, 3RS20, 3RS21		Adhesive labels For SIRIUS devices				
	• 19 mm x 6 mm, pastel turquoise	C	3RT1900-1SB60		100	3 060 units	41B
	• 19 mm x 6 mm, zinc yellow	C	3RT1900-1SD60		100	3 060 units	41B
Push-in lugs and covers							
 3RP1903	For 3RS10, 3RS11, 3RS20, 3RS21		Push-in lugs For screw fixing, 2 units are required for each device				
		B	3RP1903		1	10 units	41H
 3RP1902	For 22.5 mm wide 3RS10, 3RS11, 3RS20, 3RS21		Sealable covers For securing against unauthorized adjustment of setting knobs				
		B	3RP1902		1	5 units	41H
	For 3RS10, 3RS11, 3RS20, 3RS21		Sealing foil For securing against unauthorized adjustment of setting knobs				
		▶	3TK2820-0AA00		1	1 unit	41L
Tools for opening spring-type terminals							
 3RA2908-1A	For auxiliary circuit connections		Screwdrivers For all SIRIUS devices with spring-type terminals; 3.0 mm x 0.5 mm; length approx. 200 mm, titanium gray/black, partially insulated				
		A	Spring-type terminals 		1	1 unit	41B

¹⁾ PC labeling system for individual inscription of unit labeling plates available from: murrplastik Systemtechnik GmbH, see Chapter 16, "Appendix" → "External Partners".

Matching sensors, see www.siemens.com/temperature.

Relays

SIRIUS 3RS14, 3RS15 Temperature Monitoring Relays for IO-Link **NEW**

General data

Overview



SIRIUS 3RS14, 3RS15 temperature monitoring relay

The temperature monitoring relays for IO-Link are used to measure temperatures in solid, liquid and gas media.

The temperature is calculated using a sensor in the medium, evaluated by the device and monitored up to two limit values for overshooting or undershooting a working range (window function).

In addition to warnings and disconnection in case of temperature deviations, the devices can also be used as a temperature controller (one-point, two-point or three-point control).

The devices differ from one another in terms of the type and number of connectable temperature sensors.

- 3RS14: Connection for resistance sensor
- 3RS15: Connection for thermocouples

Function	Temperature monitoring relays		
	3RS1440	3RS1441	3RS1540
Connectable sensor type			
Number of sensors monitored	1	3	1
Resistance sensor	✓	✓	--
Thermocouples	--	--	✓
Temperature monitoring			
Temperature monitoring – overshoot	✓	✓	✓
Temperature monitoring – undershoot	✓	✓	✓
Number of adjustable limit values	2	2	2

✓ Function supported

-- Function not supported

10

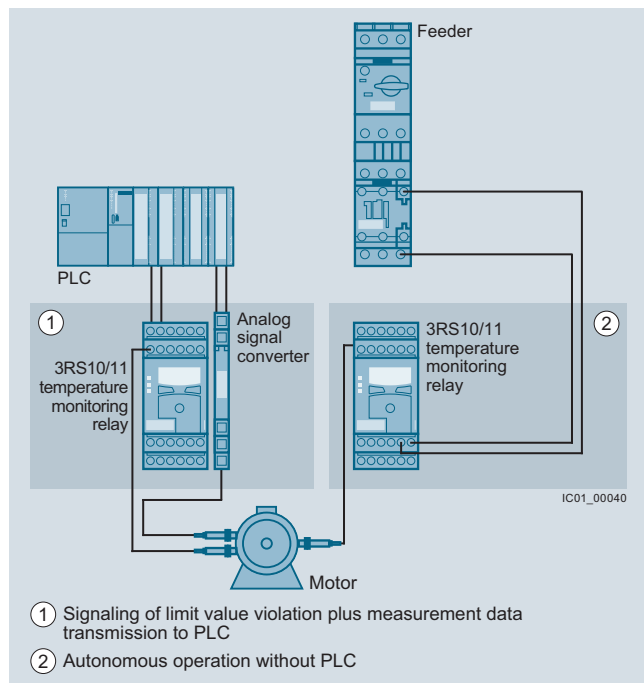

Conventional temperature monitoring relays

Notes:

Devices required for the communication via IO-Link:

- Any controller that supports the IO-Link (e.g. ET 200SP with CPU or S7-1200), see [Catalog ST 70 "Products for Totally Integrated Automation"](#)
- IO-Link-Master (e.g. CM 4xIO-Link for SIMATIC ET 200SP or SM 1278 for S7-1200), see [Catalog ST 70 "Products for Totally Integrated Automation"](#)

Each monitoring relay requires an IO-Link channel.

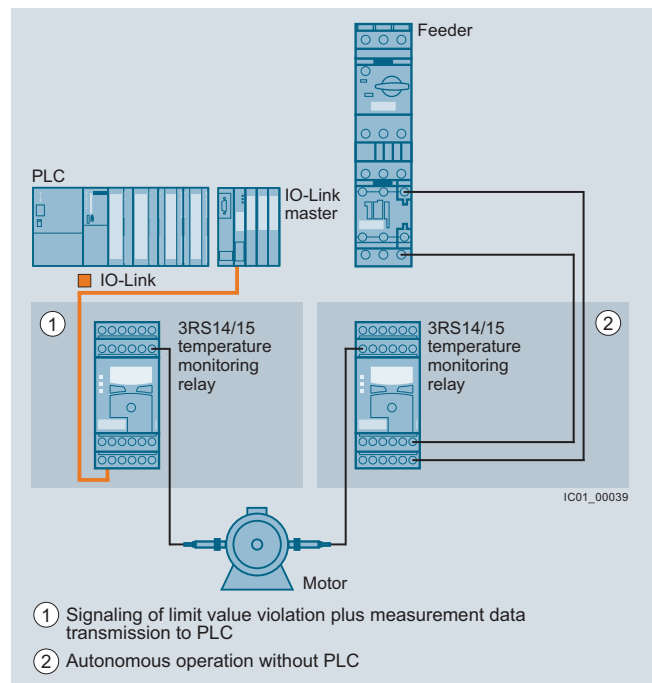

Temperature monitoring relays for IO-Link

Notes on safety

System networking requires suitable protective measures (including network segmentation for IT security) in order to ensure safe plant operation.

More information about the subject of Industrial Security, see www.siemens.com/industrialsecurity.

Article No. scheme

Digit of the Article No.	1st - 3rd	4th	5th	6th	7th	8th	9th	10th	11th	12th
	□□□	□	□	□	□	-	□	□	□	□
Temperature monitoring relays	3 R S									
Device type		□	□							
Version and type of sensor				□	□					
Connection methods							□			
Number and type of outputs								□		
Control supply voltage									□	
Measuring range										□
Special versions										□
Example	3 R S	1	4	4	0	-	1	H	B	5 0

Note:

The Article No. scheme is presented here merely for information purposes and for better understanding of the logic behind the article numbers.

For your orders, please use the article numbers quoted in the catalog in the Selection and ordering data.

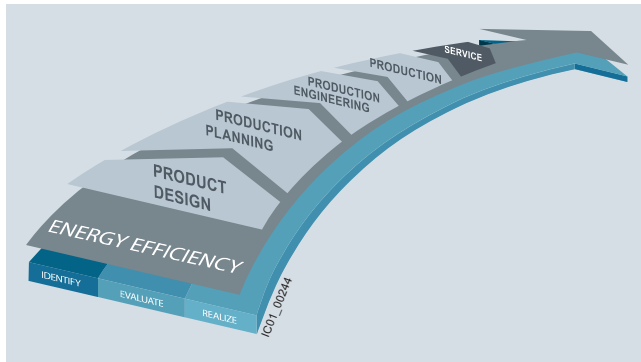
Benefits**Advantages through energy efficiency**

Overview of the energy management process

We offer you a unique portfolio for industrial energy management, using an energy management system that helps to optimally define your energy needs. We split up our industrial energy management into three phases – identify, evaluate, and realize – and we support you with the appropriate hardware and software solutions in every process phase.

The innovative SIRIUS industrial controls products can also make a major contribution to the energy efficiency of a plant (www.siemens.com/sirius/energysaving).

The 3RS14 and 3RS15 monitoring relays for IO-Link make the following contribution to the energy efficiency of the plant as a whole:

- Demand-based control of heating and ventilation in the process and in the control cabinet

Technical specifications**Connection for resistance sensors****Two-wire measurement**

When two-wire temperature sensors are used, the resistances of the sensor and wiring are added. The resulting systematic error must be taken into account when the signal evaluation unit is calibrated. A jumper must be clamped between terminals T2 and T3 for this purpose.

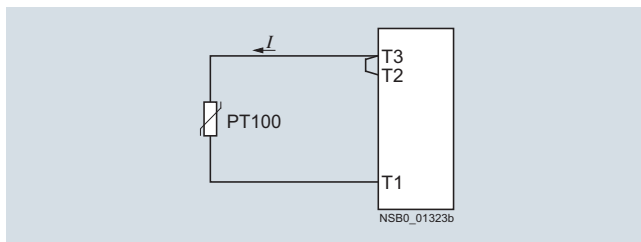
**Wiring errors**

The errors that are generated by the wiring comprise approximately 2.5 K/Ω. If the resistance of the cable is not known and cannot be measured, the wiring errors can also be estimated using the following table.

Temperature drift dependent on the length and cross-section of the cable with PT100 sensors and an ambient temperature of 20 °C, in K:

Cable length in m	Cross-section mm ²			
	0.5	0.75	1	1.5
	Temperature drift in K:			
0	0	0	0	0
10	1.8	1.2	0.9	0.6
25	4.5	3.0	2.3	1.5
50	9.0	6.0	4.5	3.0
75	13.6	9.0	6.8	4.5
100	18.1	12.1	9.0	6.0
200	36.3	24.2	18.1	12.1
500	91.6	60.8	45.5	30.2

Example: On a PT100 sensor with a cable length of 10 m and a conductor cross-section of 1 mm² the temperature drift equals 0.9 K.

Relays

SIRIUS 3RS14, 3RS15 Temperature Monitoring Relays for IO-Link **NEW**

General data

Three-wire measurement

To minimize the effects of the line resistances, a three-wire circuit is often used. Using the additional cable, two measuring circuits can be formed of which one is used as a reference. The signal evaluation unit can then automatically calculate the line resistance and take it into account.

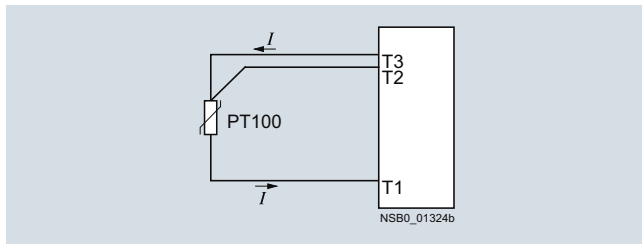

Connection of thermocouples

Based on the thermo-electrical effect, a differential temperature measurement will be performed between the measuring point and the signal evaluation unit.

This principle assumes that the signal evaluation unit knows the temperature at the clamping point (T2). For this reason, the 3RS15 temperature monitoring relay has an integral compensator that determines this comparison temperature and builds it into the result of the measurement. The thermal sensors and cables must be insulated therefore.

The absolute temperature is therefore calculated from the ambient temperature of the signal evaluation unit and the temperature difference measured by the thermoelement.

Temperature detection is therefore possible (T1) without needing to know the precise ambient temperature of the clamping point at the signal evaluation unit (T2).

The connecting cable is only permitted to be extended using connecting leads that are made from the same material as the thermocouple. If a different type of conductor is used, an error will result in the measurement.

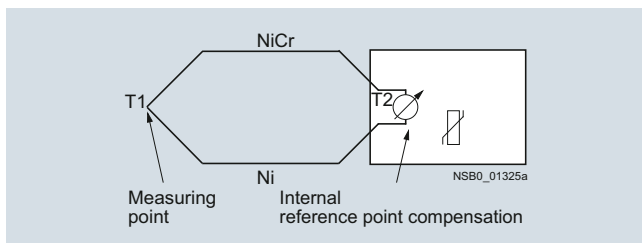

For more information, see

www.feldgeraete.de/76/produkte/fuw.html

www.ephy-mess.de

or from

EPHY-MESS GmbH, see Chapter 16 "Appendix"
→ "External Partners".

Principle of operation

When the temperature has reached the set upper limit value ϑ_1 , the K1 output relay changes its switching state after the configured time t has expired. The delay time can be adjusted. The K2 output relay responds in the same manner to the lower limit value of ϑ_2 .

The output relays return immediately to their original state (the RESET response is configured at Auto RESET) once the temperature reaches the respective hysteresis value.

Both limit values ϑ_1 and ϑ_2 can be parameterized for overshooting or undershooting. This makes it possible to use a limit value for issuing an alarm signal to announce that a limit value is about to be overshoot or undershot. The other limit value can be used for disconnection or to implement two-point or three-point control.

Note:

The "Temperature monitoring mode" parameter can be used to set the desired type of monitoring (monitoring for overshooting or undershooting or range monitoring).

With the closed-circuit principle selected

Temperature overshoot

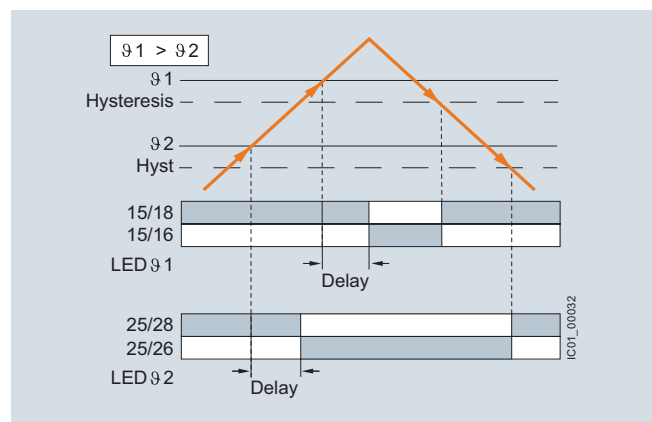

Temperature undershoot

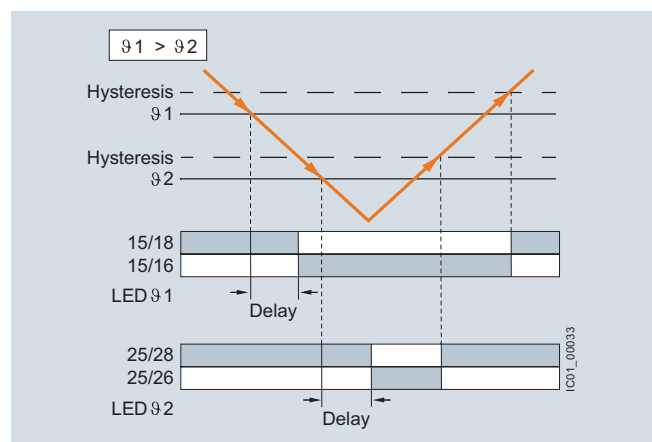

With the closed-circuit principle selected

Range monitoring

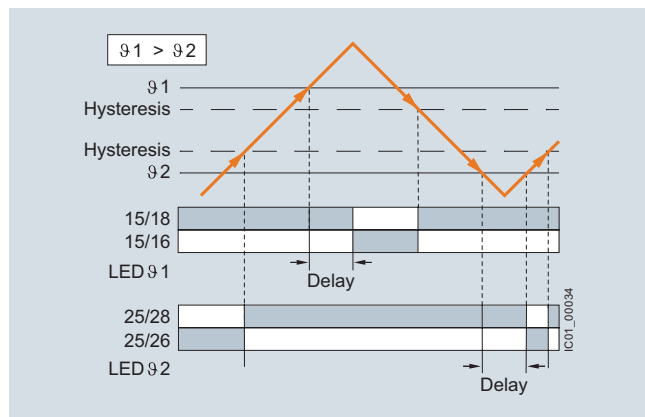

Storage function

The digitally adjustable temperature monitoring relays for IO-Link have a memory function. The memory function is illustrated below by the example of a temperature overshoot.

When the temperature has reached the $\vartheta 1$ limit value, the K1 output relay changes its switching state after the configured time t has expired (output relay K2 reacts similarly at $\vartheta 2$).

The temperature monitoring relays for IO-Link respond as described below:

- With temperature monitoring relays for IO-Link the memory function is activated as standard (RESET). The output relays only return to the original state when the temperature falls below the set hysteresis value and when one of the following steps is performed:
 - Brief jumpering of the Y3/Y4 terminals
 - Set the rotary knob to "RUN" position and press the right-hand arrow key
 - Perform a RESET through IO-Link
- If the Y3/Y4 terminals are permanently jumpered, the memory function is deactivated (Auto RESET). The output relays return immediately to their original state once a previously occurred fault has been rectified and the temperature falls below the respective hysteresis value.

With the closed-circuit principle selected

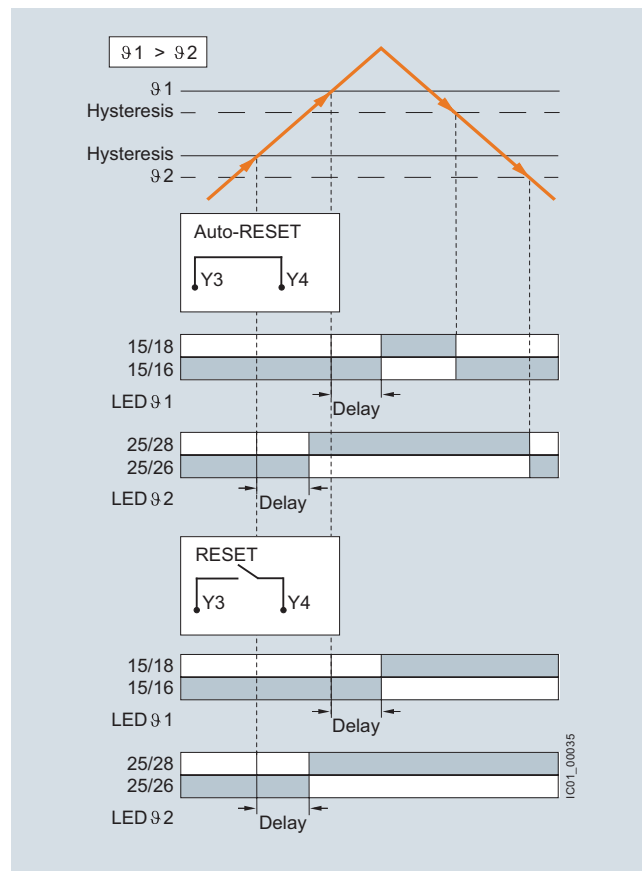

Relays

SIRIUS 3RS14, 3RS15 Temperature Monitoring Relays for IO-Link

NEW

General data

Characteristic curves

For resistance sensors

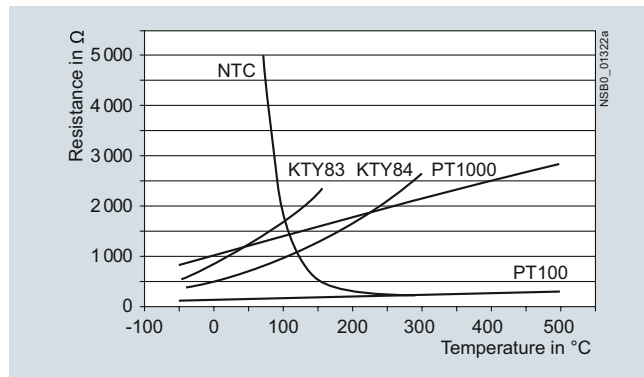

The short-circuit and open-circuit detection as well as the measuring range is limited, depending on the sensor type.

Measuring ranges for resistance sensors

Sensor type	Short circuit	Open circuit	3RS1440, 3RS1441 Measuring range in °C	Measuring range in °F
PT100	✓	✓	-50 ... +750	-58 ... +1 382
PT1000	✓	✓	-50 ... +500	-58 ... +932
KTY83-110	✓	✓	-50 ... +175	-58 ... +347
KTY84	✓	✓	-40 ... +300	-40 ... +572
NTC ¹⁾	✓	--	+80 ... +160	+176 ... +320

✓ Detection possible
-- Detection not possible

¹⁾ NTC type: B57227-K333-A1 (100 °C: 1.8 kΩ; 25 °C: 32.762 kΩ).

For thermocouples

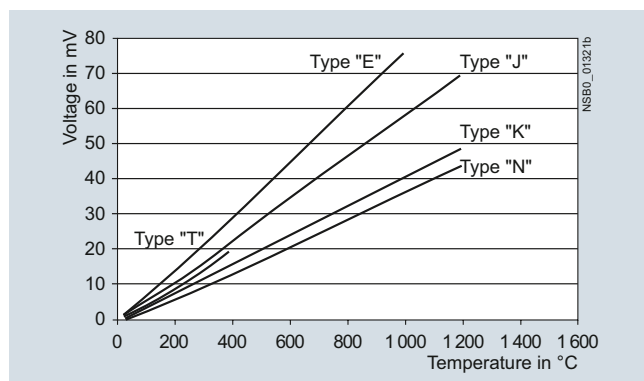

Characteristic curves for sensor types K, N, J, E and T

Measuring ranges for thermocouples

Sensor type	Short circuit	Open circuit	3RS1540 Measuring range in °C	Measuring range in °F
K	--	✓	-99 ... +1 350	-146.2 ... +2 462
N	--	✓	-99 ... +1 300	-146.2 ... +2 372
J	--	✓	-99 ... +1 200	-146.2 ... +2 192
E	--	✓	-99 ... +999	-146.2 ... +1 830.2
T	--	✓	-99 ... +400	-146.2 ... +752
S	--	✓	0 ... 1 750	32 ... 3 182
R	--	✓	0 ... 1 750	32 ... 3 182
B	--	✓	400 ... 1 800	752 ... 3 272

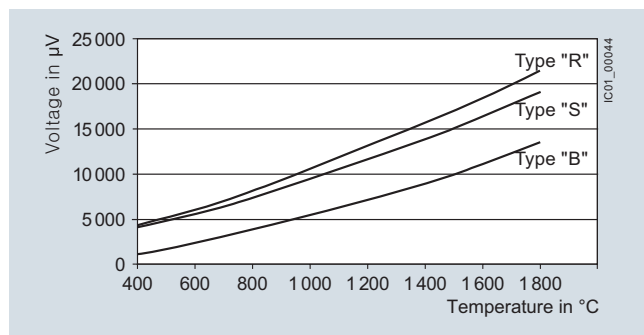

✓ Detection possible
-- Detection not possible



Characteristic curves for sensor types S, R and B

NEW SIRIUS 3RS14, 3RS15 Temperature Monitoring Relays for IO-Link

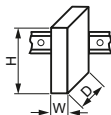
General data

Type	3RS14, 3RS15	
General technical specifications		
Dimensions (W x H x D)		
• Screw terminals	mm	45 x 106 x 91
• Spring-type terminals	mm	45 x 108 x 91
		
Permissible ambient temperature		
• During operation	°C	-25 ... +60
Connection type		
		 Screw terminals
• Terminal screw		M3 (for standard screwdriver, size 2 and Pozidriv 2)
• Solid	mm ²	1 x (0.5 ... 4), 2 x (0.5 ... 2.5)
• Finely stranded with end sleeve	mm ²	1 x (0.5 ... 2.5), 2 x (0.5 ... 1.5)
• AWG cables, solid or stranded	AWG	2 x (20 ... 14)
• Tightening torque	Nm	0.8 ... 1.2
Connection type		
		 Spring-type terminals
• Solid	mm ²	2 x (0.25 ... 1.5)
• Finely stranded, with end sleeves acc. to DIN 46228	mm ²	2 x (0.25 ... 1.5)
• Finely stranded	mm ²	2 x (0.25 ... 1.5)
• AWG cables, solid or stranded	AWG	2 x (24 ... 16)

More information

For the manual "3RS14/3RS15 Temperature Monitoring Relays for IO-Link", see <http://support.automation.siemens.com/WW/view/en/54375463>.

Notes on safety

System networking requires suitable protective measures (including network segmentation for IT security) in order to ensure safe plant operation.

More information about the subject of Industrial Security, see www.siemens.com/industrialsecurity.

Relays

SIRIUS 3RS14, 3RS15 Temperature Monitoring Relays for IO-Link **NEW**

Relays, digitally adjustable for 1 sensor

Overview



SIRIUS 3RS1440 digital monitoring relay for 1 sensor

The 3RS14 and 3RS15 temperature monitoring relays for IO-Link are used to measure temperatures in solid, liquid and gas media. The temperature is calculated using a sensor in the medium, evaluated by the device and monitored for overshooting or undershooting a working range (window function). The digital temperature monitoring relays have two separately adjustable limit values, are non-volatile and can be operated as desired using the open- or closed-circuit principle.

The devices differ in terms of the number of temperature sensors which can be evaluated. The 3RS1440 and 3RS1540 for IO-Link temperature monitoring relays can be digitally adjusted for one sensor and represent an alternative to temperature controllers in the low-end range (two-point or three-point control).

The devices with two-point control can, for example, be used as a thermostat. The devices with three-point control can, for example, independently switch between heating and cooling.

The 3RS1441 temperature monitoring relays for IO-Link can be digitally adjusted to evaluate up to three resistance sensors at one time. The devices were designed specifically for monitoring motor windings and positions.

The temperature monitoring relays are powered through the control supply voltages IO-Link (L+) and ground (L-) or via an external 24 V DC power supply.

Monitoring

When the temperature has reached the ϑ_1 limit value, the K1 output relay changes its switching state after the configured time t has expired (output relay K2 reacts accordingly at ϑ_2). The delay time can be adjusted.

The output relays return immediately to their original state once the temperature reaches the respective hysteresis value.

When the temperature has reached the top ϑ_1 limit value, the K1 output relay changes its switching state after the configured time t has expired. The output relay returns immediately to its original state once the temperature reaches the respective hysteresis value.

The K2 output relay reacts in the same way at the ϑ_2 lower threshold. Both limit values ϑ_1 and ϑ_2 can be parameterized for overshooting or undershooting the thresholds. This makes it possible to use a limit value for issuing an alarm signal to announce that a limit value is about to be overshoot or undershot.

Note:

The "Temperature monitoring mode" parameter can be used to set the desired type of monitoring (monitoring for overshooting or undershooting or range monitoring).

Benefits

- Very simple operation without complicated menu selections
- Two- or three-point control can be parameterized quickly
- All versions with removable terminals
- All versions with screw or spring-type terminals

Application

The temperature monitoring relays can be used in almost any application in which temperature overshoot or undershoot is not permitted, e.g. in the monitoring of set temperature limits and the output of alarm messages for:

- Plant and environment protection
- Temperature limits for process variables e.g. in the packaging industry or electroplating
- Temperature limits for district heating plants
- Exhaust temperature monitoring
- Controlling equipment and machines such as heating, climate and ventilation systems, solar collectors, heat pumps or warm water supplies
- Motor, bearing and gear oil monitoring
- Monitoring of coolants

NEW SIRIUS 3RS14, 3RS15 Temperature Monitoring Relays for IO-Link

Relays, digitally adjustable for 1 sensor

Technical specifications

Type		3RS1440	3RS1540
Auxiliary circuit			
Rated operational currents I_e			
• AC-15/24 ... 250 V	A	3	
• DC-13 at			
- 24 V	A	1	
- 125 V	A	0.2	
- 250 V	A	0.1	
Evaluation unit			
Measuring accuracy at 20 °C ambient temperature (T20)		< ± 2 K, ± 1 digit	< ± 5 K, ± 1 digit
Reference point accuracy		--	< ± 5 K
Deviations due to ambient temperature In % of measuring range		%	0.05 °C per K deviation from T20
Measuring cycle		ms	500
Hysteresis settings for temperature		K	1 ... 99, for both values
Adjustable delay time		s	0 ... 999.9
Sensor circuit			
Typical sensor circuits			
• PT100	mA	Typically 1	--
• PT1000/KTY83/KTY84/NTC	mA	Typically 0.2	--
Open-circuit detection		✓ ¹⁾	✓
Short-circuit detection		✓	--
Three-wire conductor connection		✓ ²⁾	--
Enclosure			
Rated insulation voltage U_i Pollution degree 2		V AC	300

✓ Available

-- Not available

1) Not for NTC type B57227-K333-A1 (100 °C: 1.8 kΩ; 25 °C: 32.762 kΩ).

2) Two-wire connection of resistance sensors with wire jumper between T2 and T3.

Circuit examples

3RS1440

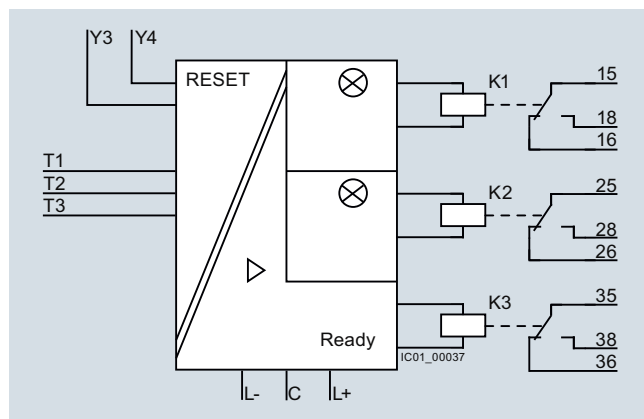

3RS1540

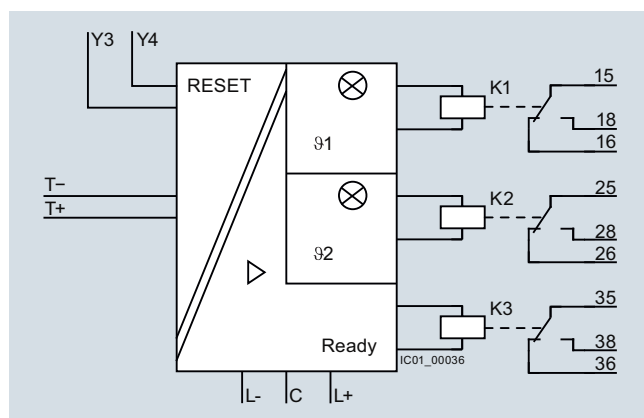

Legend

L+ = IO-Link control supply voltage

C = Communication signal

L- = IO-Link ground

K1 = Output relay for temperature limit value ϑ_1 K2 = Output relay for temperature limit value ϑ_2

K3 = Output relay for "Device is ready for operation"

 ϑ_1 = LED: "Relay K1 tripped" ϑ_2 = LED: "Relay K2 tripped"

T1 to T3 = Sensor connection for 3RS14 resistance sensor

T+/T- = Sensor connection for 3RS15 thermocouples

Y3/Y4 = RESET input

⚠ Important!

When resistance sensors with two-wire connection are used, T2 and T3 must be jumpered.

Relays

SIRIUS 3RS14, 3RS15 Temperature Monitoring Relays for IO-Link **NEW**

Relays, digitally adjustable for 1 sensor

Selection and ordering data

- To monitor temperatures with a resistance sensor or thermocouple
- Temperature range dependent on sensor type
-99 to +1 800 °C or -146.2 to +3 272 °F
- Short-circuit and open-circuit detection in sensor circuit
- Adjustable via IO-Link and locally, with illuminated LCD
- Power supply with 24 V DC via IO-Link or external auxiliary voltage
- Overshoot, undershoot or range monitoring adjustable
- Exact sensor type can be set
- 2 limit values, can be adjusted separately
- Adjustable open/closed-circuit principle
- Can be adjusted by manual or remote RESET (via an external contact)
- Actual value, tripping state for control displayed and conveyed, adjustable in °C or °F
- 1 CO contact per limit value
- 1 CO contact for monitoring sensors and devices

PU (UNIT, SET, M) = 1
PS* = 1 unit
PG = 41H



3RS1440-1HB50



3RS1540-1HB80



3RS1440-2HB50



3RS1540-2HB80

Sensors	Measuring range (limit of measuring range dependent on sensor)	Hysteresis can be adjusted for ϑ1 and ϑ2	Tripping delay time can be adjusted for ϑ1 and ϑ2 DELAY	Control supply voltage U_s	DT	Screw terminals	DT	Spring-type terminals	
		K	s	V DC		Article No.	Price per PU	Article No.	Price per PU

Temperature monitoring relay, digitally adjustable for a sensor, non-volatile fault storage can be selected

PT100/PT1000, KTY83/KTY84, NTC (resistance sensor) ¹⁾	-50 ... +750 °C or -58 ... +1 382 °F	0 ... 99	0 ... + 999.9	24	A	3RS1440-1HB50	A	3RS1440-2HB50
Type B, E, J, K, N, R, S, T (thermocouples)	- 99 ... + 1 800 °C or - 146.2 ... + 3 272 °F	0 ... 99	0 ... + 999.9	24	A	3RS1540-1HB80	A	3RS1540-2HB80

¹⁾ NTC type B57227-K333-A1 (100 °C: 1.8 kΩ; 25 °C: 32.762 kΩ).

For accessories, see page 10/181.

NEW SIRIUS 3RS14, 3RS15 Temperature Monitoring Relays for IO-Link

Relays, digitally adjustable for up to 3 sensors

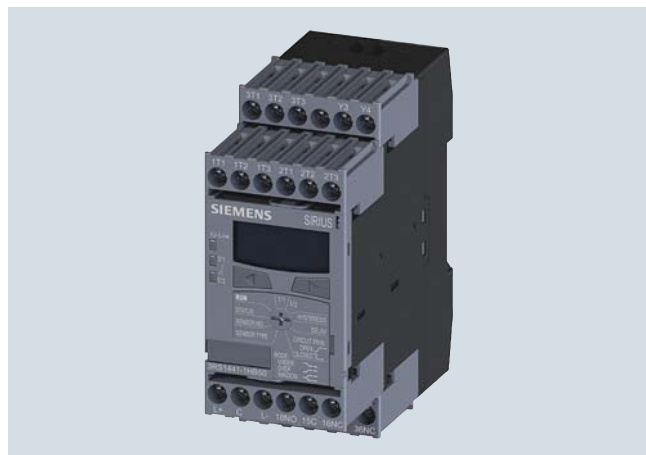
Overview

SIRIUS 3RS1441 digital temperature monitoring relay for up to 3 sensors

The 3RS14 temperature monitoring relays can be used to measure temperatures in solid, liquid and gas media. The temperature is calculated using a sensor in the medium, evaluated by the device and monitored for overshooting or undershooting a working range (window function). The devices can be parameterized to indicate the measured temperature in °C or °F. The 3RS1441 evaluation unit can evaluate up to 3 resistance sensors at the same time.

Benefits

- Very simple operation without complicated menu selections
- Space-saving with 45 mm width
- Two- or three-point control can be parameterized quickly
- All versions with removable terminals
- All versions with screw or spring-type terminals

Application

The 3RS1441 temperature monitoring relays can be used almost anywhere where several temperatures must be monitored at one time for overshooting, undershooting or staying within a certain range.

Monitoring of set temperature limits and output of alarm messages for:

- Plant and environment protection
- Temperature limits for process variables e.g. in the packaging industry or electroplating
- Controlling equipment and machines such as heating, climate and ventilation systems, solar collectors, heat pumps or warm water supplies
- Motor, bearing and gear oil monitoring
- Monitoring of coolants

Technical specifications

Type	3RS1441	
Auxiliary circuit		
Rated operational currents I_e		
• AC-15/24 ... 250 V	A	3
• DC-13 at		
- 24 V	A	1
- 125 V	A	0.2
- 250 V	A	0.1
DIAZED fuse protection		
• Operational class gG	A	4
Evaluation unit		
Measuring accuracy at 20 °C ambient temperature (T20)		< ±2 K, ±1 digit
Deviations due to ambient temperature In % of measuring range	%	0.05 per K deviation from T20
Measuring cycle	ms	500
Hysteresis settings for temperature 1	K	1 ... 99, for both values
Adjustable delay time	s	0 ... 999.9
Sensor circuit		
Typical sensor circuits		
• PT100	mA	Typically 1
• PT1000/KTY83/KTY84/NTC	mA	Typically 0.2
Open-circuit detection		✓ ¹⁾
Short-circuit detection		✓
Three-wire conductor connection		✓ ²⁾
Enclosure		
Rated insulation voltage U_i Pollution degree 2	V AC	300

✓ Available

¹⁾ Not for NTC type B57227-K333-A1 (100 °C: 1.8 kΩ; 25 °C: 32.762 kΩ).

²⁾ Two-wire connection of resistance sensors with wire jumper between T2 and T3.

Relays

SIRIUS 3RS14, 3RS15 Temperature Monitoring Relays for IO-Link NEW

Relays, digitally adjustable for up to 3 sensors

Circuit example

3RS1441

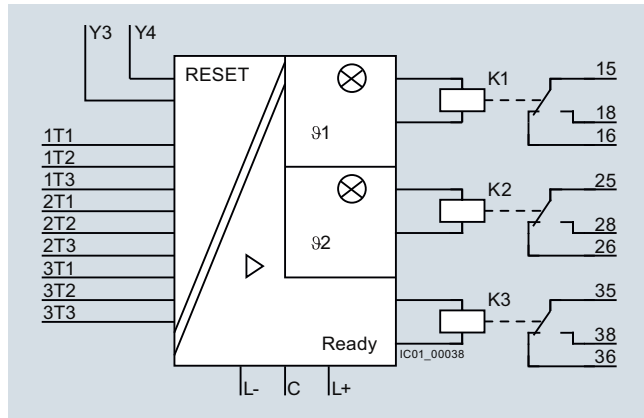

Legend

- L+ = IO-Link control supply voltage
- C = Communication signal
- L- = IO-Link ground
- K1 = Output relay for temperature limit value $\vartheta 1$
- K2 = Output relay for temperature limit value $\vartheta 2$
- K3 = Output relay for "Device is ready for operation"
- $\vartheta 1$ = LED: "Relay K1 tripped"
- $\vartheta 2$ = LED: "Relay K2 tripped"
- Y3/Y4 = RESET input for 3RS14, 3RS15
- 1T1 to 1T3 = Sensor connection for resistance sensor 1
- 2T1 to 2T3 = Sensor connection for resistance sensor 2
- 3T1 to 3T3 = Sensor connection for resistance sensor 3
- Y3/Y4 = RESET input for 3RS14

⚠ Important!

When resistance sensors with two-wire connection are used, T2 and T3 must be jumpered.

Selection and ordering data

- For temperature monitoring with up to 3 resistance sensors
- Temperature range dependent on sensor type
-50 to +750 °C or -58 to +1 382 °F
- Short-circuit and open-circuit detection in sensor circuit
- Adjustable via IO-Link and locally, with illuminated LCD
- Power supply with 24 V DC via IO-Link or external auxiliary voltage
- Overshoot, undershoot or range monitoring adjustable
- Exact sensor type and number of sensors can be set
- 2 limit values, can be adjusted separately
- Adjustable open/closed-circuit principle
- Can be adjusted by manual or remote RESET (via an external contact)
- Actual value, tripping state for control displayed and conveyed, adjustable in °C or °F
- 1 CO contact per limit value
- 1 CO contact for monitoring sensors and devices

- PU (UNIT, SET, M) = 1
- PS* = 1 unit
- PG = 41H

10



3RS1441-1HB50







3RS1441-2HB50

Sensors	Number of sensors that can be set	Measuring range (limit of measuring range dependent on sensor)	Hysteresis can be adjusted for $\vartheta 1$ and $\vartheta 2$	Tripping delay time can be adjusted for $\vartheta 1$ and $\vartheta 2$ DELAY	Control supply voltage U_s	DT	Screw terminals	DT	Spring-type terminals	
							Article No.	Price per PU	Article No.	Price per PU
Temperature monitoring relay, digitally adjustable for up to 3 sensors, non-volatile fault storage can be selected										
PT100/PT1000, KTY83/KTY84, NTC (resistance sensor) ¹⁾	1 ... 3 sensors	- 50 ... +750 °C or -58 ... +1 382 °F	0 ... 99	0 ... 999.9	24	A	3RS1441-1HB50	A	3RS1441-2HB50	

¹⁾ NTC type: B57227-K333-A1 (100 °C: 1.8 k Ω ; 25 °C: 32.762 k Ω).

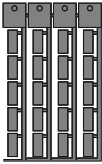
For accessories, see page 10/181.

Selection and ordering data

Use	Version	DT	Article No.	Price per PU	PU (UNIT, SET, M)	PS*	PG
Blank labels							
 3RT2900-1SB20	For 3RS14 and 3RS15		Unit labeling plates For SIRIUS devices 20 mm x 7 mm, titanium gray ¹⁾	D	3RT2900-1SB20	100	340 units 41B
	For 3RS14 and 3RS15		Adhesive labels For SIRIUS devices	C	3RT1900-1SB60	100	3 060 units 41B
			<ul style="list-style-type: none"> • 19 mm x 6 mm, pastel turquoise • 19 mm x 6 mm, zinc yellow 	C	3RT1900-1SD60	100	3 060 units 41B
Push-in lugs and covers							
 3RP1903	For 3RS14 and 3RS15		Push-in lugs For screw fixing, 2 units are required for each device	B	3RP1903	1	10 units 41H
	For 3RS14 and 3RS15		Sealing foil For securing against unauthorized adjustment of setting knobs	▶	3TK2820-0AA00	1	1 unit 41L
Tools for opening spring-type terminals							
 3RA2908-1A	For auxiliary circuit connections		Screwdrivers For all SIRIUS devices with spring-type terminals 3.0 mm x 0.5 mm, length approx. 200 mm, titanium gray/black, partially insulated	A	Spring-type terminals 	1	1 unit 41B
					3RA2908-1A		

¹⁾ PC labeling system for individual inscription of unit labeling plates available from: murrplastik Systemtechnik GmbH, see Chapter 16, "Appendix" → "External Partners".

Matching sensors, see www.siemens.com/temperature.

Relays

SIRIUS 3RN1 Thermistor Motor Protection

For PTC sensors

Overview



SIRIUS 3RN1 thermistor motor protection

Thermistor motor protection devices are used for direct monitoring of the motor winding temperature. For this purpose, the motors are equipped with temperature-dependent resistors (PTC) that are directly installed in the motor winding and abruptly change their resistance at their temperature limit.

Article No. scheme

Digit of the Article No.	1st - 5th	6th	7th	8th	9th	10th	11th	12th
	□□□□□	□	□	-	□	□	□	□
Thermistor motor protection	3 R N 1 0							
Number and version of the sensor circuits	□							
RESET response	□							
Connection type	□							
Type and number of outputs	□							
Control supply voltage	□							
Protective separation	□							
Behavior in the event of voltage failure	□							
Example	3	R	N	1	0	0	0	0

Note:

The Article No. scheme is presented here merely for information purposes and for better understanding of the logic behind the article numbers.

For your orders, please use the article numbers quoted in the catalog in the Selection and ordering data.

Benefits

- Thanks to direct motor protection, overdimensioning of the motors is not necessary
- No settings on the device are necessary
- Semiconductor compatible output thanks to versions with hard gold-plated contacts
- Rapid error diagnosis thanks to versions that indicate open and short circuits in the sensor circuit
- All versions with removable terminals
- All versions with screw terminals or spring-type terminals

Application

Direct motor protection through temperature monitoring of the motor winding offers 100 % motor protection even under the most difficult ambient conditions, without the need to make adjustments on the device. Versions with hard gold-plated contacts ensure, in addition, a high switching reliability that is even higher than an electronic control.

Direct motor protection

- At increased ambient temperatures
- When switching frequency is too high
- When start up and braking procedures are too long
- Used together with frequency converters (low speeds)

ATEX approval for operation in areas subject to explosion hazard

The SIRIUS 3RN1 thermistor motor protection relay for PTC sensors is certified according to ATEX Ex II (2) G and D for environments with explosive gas or dust loads.

Motor protection using current- and temperature-dependent protective devices

EN 60204 and IEC 60204 stipulate that motors must be protected from overheating at a rating of 0.5 kW and higher. The protection can take the form of overload protection, overtemperature protection or current limiting.

For motors with frequent starting and braking and in environments where cooling may be impaired (e.g. by dust), it is recommended to use the overtemperature protection option in the form of a protective device coordinated with this mode of operation. A good choice in this case is the use of 3RN1 thermistor motor protection devices.

On rotor-critical motors, overtemperature detection in the stator windings can lead to delayed and hence inadequate protection. In this case the standards stipulate additional protection, e.g. by means of an overload relay.

This combination of thermistor motor protection and an overload relay is recommended for full motor protection in case of frequent starting and braking of motors, irregular intermittent duty or excessive switching frequency. To prevent premature tripping of the overload relay in such operating conditions, a higher setting than that normally required for the operational current is chosen. The overload relay then performs the stall protection, and the 3RN1 thermistor motor protection device monitors the temperature of the motor windings.

Application	Motor protection		
	Only current-dependent, e.g. with overload relay	Only temperature-dependent, e.g. with thermistor motor protection relay	Current- and temperature-dependent
Motor protection in case of			
Overloading in uninterrupted duty	✓	✓	✓
Long start up and braking operations	○	✓	✓
Irregular intermittent duty	○	✓	✓
Excessively high switching frequency	○	✓	✓
Single-phase operation and current unbalance	✓	✓	✓
Voltage and frequency fluctuations	✓	✓	✓
Stalling of the rotor	✓	✓	✓
Switching on a stalled rotor of a stator-critical motor	✓	✓	✓
Switching on a stalled rotor of a rotor-critical motor	✓	○	✓
Elevated ambient temperature	--	✓	✓
Impeded cooling	--	✓	✓

✓ Full protection
○ Conditional protection
-- No protection

Technical specifications

The 3RN1 evaluation units are suitable for use in any climate and finger-safe according to EN 50274.

They comply with:

- IEC 60947-8. Low-voltage switchgear and controlgear – Part 8: "Control units for built-in thermal protection (PTC) for rotating electrical machines"
- IEC 61000-6-2 and IEC 61000-6-4 "Electromagnetic compatibility of I&C equipment in industrial process engineering"

The terminals of the auxiliary contacts are designated in accordance with EN 60947-1.

The 3RN1 evaluation units are suitable for snap-on mounting onto TH 35 standard mounting rails according to IEC 60715 or for screw fixing using an adapter (Accessories).

Any mounting position is possible.

For devices with the "Manual RESET" function, the test function can be activated and a trip simulated by pressing the blue Test/RESET button for > 2 seconds.

If a Type A temperature sensor is connected to a Type A evaluation unit, compliance with the operating temperatures is assured (on pick-up and reset) according to IEC 60947-8.

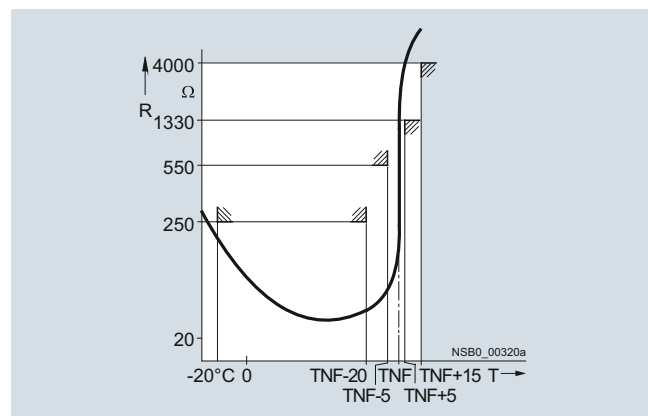

Characteristic curve of the 3RN1 evaluation unit

The characteristic curves of the Type A temperature sensors are described in IEC 60947-8, DIN 44081 and EN 44082 standards.

Relays

SIRIUS 3RN1 Thermistor Motor Protection

For PTC sensors

Use in areas subject to explosion hazard for gases

All devices are approved for Equipment Group II, Category (2) in Area "G" (areas that contain explosive gases, vapor, spray and air mixtures).

With PTB 01 ATEX 3218 ex II (2) G, compliance with directive 94/9 EC Appendix II is confirmed. The safety devices must be selected with suitable settings for the safe operation of motors of the "Increased safety" (EEx e) and "Flameproof enclosure" (EEx d) types of protection and are used outside the area subject to explosion hazard.

PTB 01 ATEX 3218 ex II (2) G

The increased danger in areas subject to explosion hazard demands careful analysis of the operating manual, the safety and commissioning instructions and the standard (EN 60079-14/VDE 0165) for electronic equipment in areas subject to gas explosion hazards.

A risk analysis must be performed for the complete plant or machine. If this risk analysis results in a minimal potential for danger (Safety Category 1), all 3RN1 TMS evaluation units can be implemented taking into account the safety notes. In the case of plants or machines with a high potential risk, device versions with integrated short-circuit detection in the sensor circuit are necessary.

Use in areas subject to explosion hazard for dust

PTB 01 ATEX 3218 ex II (2) GD

3RN1011-.B/-G, 3RN1012-.B/-G and 3RN1013-...0 evaluation units can be used as protective devices for motors in areas subject to gas explosion hazard for protection against impermissible overheating due to overload. If the ATEX identification has the extension "D:=Dust", these units can also be used as protective devices for motors in areas subject to dust explosion hazard (IEC 61241-14).

Additional information is provided in the EC type test certificate which can be obtained from the Internet. The units comply with the requirements of the following classes:

Device	Class
3RN1000, 3RN1010, 3RN1011-.C, 3RN1012-.C, 3RN1022, 3RN1062	EN ISO 13849-1: Category 1
3RN1011-.B, 3RN1011-.G, 3RN1012-.B, 3RN1012-.G, 3RN1013	EN ISO 13849-1: Category 2

The measuring circuit leads must be routed as separate control cables. It is not permitted to use cores from the supply line of the motor or any other main supply cables. If extreme inductive or capacitive interference is expected as a result of power lines routed in parallel, shielded control cables must be used.

Cable routing

Maximum cable length for sensor circuit cables

Cable cross-section	Cable length for evaluation units	
	Without short-circuit detection	With short-circuit detection ¹⁾
	3RN1000, 3RN1010, 3RN1011-.C, 3RN1012-.C, 3RN1022, 3RN1062	3RN1011-.B/-G, 3RN1012-.B/-G, 3RN1013
mm ²	m	m
2.5	2 x 2 800	2 x 250
1.5	2 x 1 500	2 x 150
0.5	2 x 500	2 x 50

¹⁾ A short circuit in the sensor circuit will be detected up to this maximum cable length.

Notes:

Tripping of the thermistor motor protection relay even in combination with a converter must directly result in disconnection. This must be implemented with circuitry.

Mounting and installation must only be performed by qualified personnel who observe the applicable regulations! For mounting, use the mounting instructions Article No.: 3ZX1012-ORN10-1AA1.

The 3RN10 is not intended for installation in hazardous areas. For installation in areas subject to explosion hazards, the 3RN10 must be enclosed in a flameproof casing.

For evaluation units with a 24 V AC/DC control voltage, electrical separation must be secured with a battery network or a safety transformer.

When evaluation units with Auto RESET function are used, resetting is performed automatically after the cooling time has expired. It must be ensured by means of an external interlock (latching with a separate ON and OFF button) that the machine to be monitored does not start up again spontaneously.

Units with the "Auto RESET" function must not be used in applications in which the unexpected restart can lead to personal injury or property damage.

In the case of evaluation units without short-circuit detection, during commissioning or after modifications or maintenance work (assembly, disassembly) on the equipment, the sensor resistance must be measured using a suitable measuring device. For resistances of < 50 W the sensor circuit must be checked for a short circuit.

If 3RN1000 units are used to protect EEx e motors, separate monitoring of the control voltage is recommended because there is no Ready LED to indicate connection to the supply voltage.

If 3RN1013-.BW01 unit are used to protect EEx e motors, separate monitoring of the control voltage is recommended because the switching state of the auxiliary contacts does not change if the control voltage fails (use of a bistable relay is recommended).

Before commissioning, the effectiveness of the protection function must be checked.

Principle of operation

The 3RN1 evaluation units operate in accordance with the closed-circuit principle and therefore monitor themselves for open circuit (except: warning output in the case of 3RN1022). A momentary voltage failure of less than 50 ms does not change the status of the auxiliary contacts. The 3RN1011, 3RN1012 and 3RN1013 units with 2 changeover contacts are also equipped with short-circuit detection in the sensor circuit. The unit will trip in the event of a short circuit in the sensor circuit (resistance in sensor circuit < 20 Ω).

All evaluation units (except for 24 V AC/DC) feature electrical separation between the control circuit and the sensor circuit.

3RN1000 compact evaluation unit

The compact unit is equipped with a red LED (TRIPPED) for the tripped indicator and a changeover contact.

After the unit has tripped, it is automatically reset once the thermistors have cooled down. The root of the changeover contact is connected to the control voltage (95 is connected to terminal A1).

This unit is particularly suitable in circuits in which the control circuit and signaling circuit have the same potential, e.g. in local control cabinets.

3RN1010, 3RN1011, 3RN1012, 3RN1013 standard evaluation units

The standard units are equipped with two LEDs (READY and TRIPPED) for an operating and tripped display and are available with either 1 NO + 1 NC or with 2 CO contacts. They are available depending on the version with Auto RESET (3RN1010), Manual/Remote RESET (3RN1011) or Manual/Auto and Remote RESET (3RN1012 and 3RN1013). Remote RESET can be achieved by connecting an external pushbutton with a normally-open function to terminals Y1 and Y2. If terminals Y1 and Y2 are bridged, tripping will be followed by an Auto RESET.

The 3RN1011, 3RN1012 and 3RN1013 units with 2 CO contacts also have short-circuit monitoring in the sensor circuit.

The 3RN1012 and the 3RN1013 are non-volatile. This means that even if the control supply voltage fails, a trip preceding it will be saved.

In the case of the 3RN1013 evaluation unit, tripping due to a short circuit in the sensor circuit will be indicated by a flashing red LED. The monostable version also indicates open circuit in the sensor circuit by flashing of the red LED.

3RN1022 "Warning and disconnection" evaluation units

Two sensor circuits can be connected to one 3RN1022 evaluation unit that acts on one output relay with 1 NO contact for warning and 1 CO contact for disconnection. Temperature sensors with different rated response temperatures TNF are used to implement the "Warning" and "Disconnection" functions. When the "Warning" sensor circuit responds, a yellow LED is lit and when the "Disconnection" circuit responds, a red LED is lit.

The sensor circuits have a different reset response and operating behavior:

- "Warning" (terminals 2T1, T2) only features Auto RESET and uses the open-circuit principle
- "Disconnection" (terminals 1T1, T2) can be changed from Manual RESET to Auto RESET by linking terminals Y1 and Y2. Remote RESET is implemented by connecting an external pushbutton with a normally-open function

3RN1062 multiple motor protection evaluation units

Up to 6 sensor circuits can be connected to the 3RN1062 evaluation unit, all of which act on one output relay. The simultaneous protection of several motors (up to 6) is an advantage for multi-motor drives (e.g. if one motor is overloaded, all the other motors of the drive will be shut down). Apart from the red LED "TRIPPED", which signals the switching state of the evaluation unit, an LED is assigned to each sensor circuit which indicates the sensor circuit that has responded during tripping. Unused sensor circuits must be short-circuited.

The reset response of the 3RN1062 evaluation units can be changed from Manual RESET to Auto RESET by linking terminals Y1 and Y2. Remote RESET is implemented by connecting an external pushbutton with a normally-open function.

Response of the evaluation units in the event of control voltage failure

Behavior	Monostable	Non-volatile, monostable	Bistable
	3RN1000, 3RN1010, 3RN1011	3RN1012, 3RN1013-...0, 3RN1022, 3RN1062	3RN1013-...01
In case of failure of the control voltage	Device trips	Device trips	No change in switching state of the auxiliary contacts
In case of return of the control voltage without a preceding tripping operation	Device resets	Device resets	No change in switching state of the auxiliary contacts
In case of return of the control voltage after a preceding tripping operation	Device resets	The device remains tripped	No change in switching state of the auxiliary contacts

Protective separation

All circuits (outputs, control circuits, sensors and RESET circuits) of the multifunction evaluation units 3RN1013-1BW10 and 3RN1013-1GW10 (wide voltage range, monostable output relay and screw connection) are safely isolated from each other up to a rated voltage of 300 V according to IEC 60947-1.

Relays

SIRIUS 3RN1 Thermistor Motor Protection

For PTC sensors

Function diagrams

3RN1000, 3RN1010 (Auto RESET)

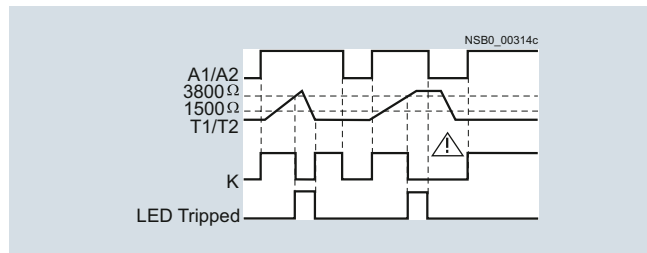

3RN1013-BW01

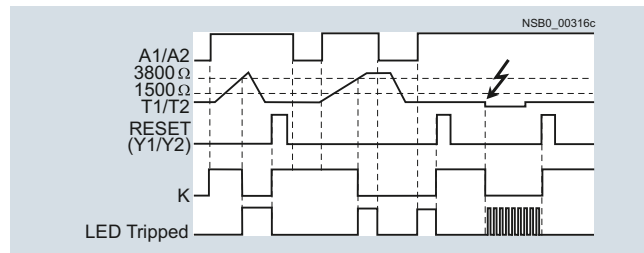

3RN1011¹⁾

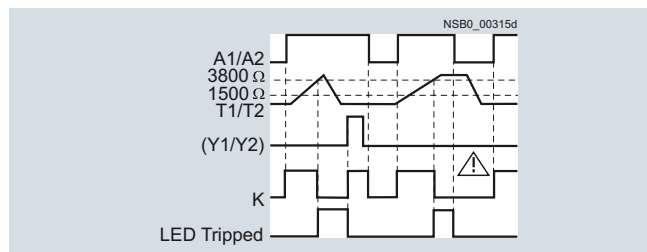

3RN1013-...00

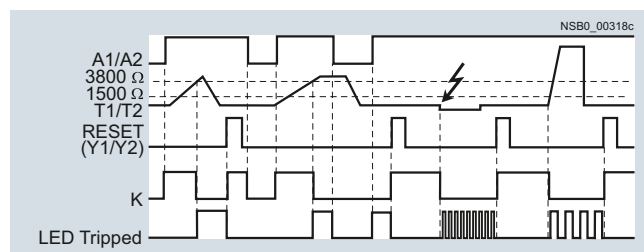

3RN1012/3RN1022/3RN1062¹⁾

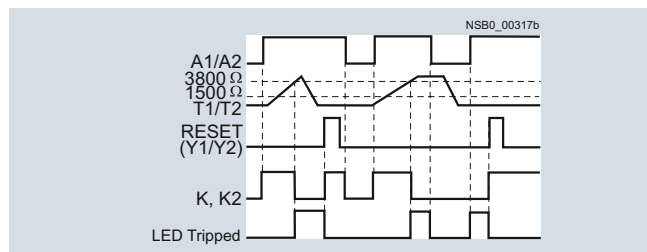

3RN1022 only

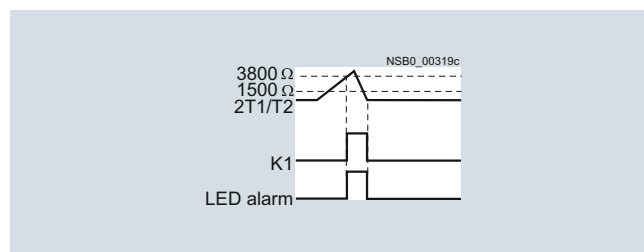

¹⁾ For versions with 2 CO contacts and short-circuit detection in the sensor circuit, see function diagram 3RN1013.



10

Type	Compact units		Standard devices		Multifunction units	Warning + disconnection	Multiple motor protection
	3RN1000	3RN1010	3RN1011	3RN1012	3RN1013	3RN1022	3RN1062
General data							
Dimensions (W x H x D)							
• For 2 terminal blocks							
- Screw terminals	mm	22.5 x 83 x 91					45 x 83 x 91
- Spring-type terminals	mm	22.5 x 84 x 91					45 x 84 x 91
• For 3 terminal blocks							
- Screw terminals	mm	22.5 x 92 x 91					--
- Spring-type terminals	mm	22.5 x 94 x 91					--
• For 4 terminal blocks							
- Screw terminals	mm	22.5 x 102 x 91					45 x 106 x 91
- Spring-type terminals	mm	22.5 x 103 x 91					45 x 108 x 91
Number of connectable sensor circuits	1					2	6
Response in the event of control voltage failure	See page 10/185						
Manual RESET	--		✓				
Auto RESET	✓		--	✓			
Remote RESET	--		✓ ¹⁾	✓			
TEST button	--		✓				
Short-circuit detection for sensor circuit	--		✓ (for 2-CO units)		✓ ²⁾	--	
Short-circuit and open-circuit display	--				✓ ²⁾	--	
Warning and disconnection in one unit	--					✓	--
Permissible ambient temperature							
• During operation	°C	-25 ... +60					

✓ Function available
 -- Function not available

¹⁾ Remote RESET possible by disconnecting control voltage.

²⁾ Open circuits are only indicated by monostable versions (3RN1013-...0).

Type	Compact units		Standard devices			Multifunction units	Warning + disconnection	Multiple motor protection
	3RN1000	3RN1010	3RN1011	3RN1012	3RN1013	3RN1022	3RN1062	
Evaluation unit								
Rated insulation voltage U_i (pollution degree 3)	V	300						
Rated impulse withstand voltage U_{imp}	kV	4						
Connection type		 Screw terminals						
<ul style="list-style-type: none"> Terminal screw Solid Finely stranded with end sleeve AWG cables, solid or stranded 	mm ² mm ² AWG	M3 (for standard screwdriver, size 2 and Pozidriv 2) 1 x (0.5 ... 4)/2 x (0.5 ... 2.5) 1 x (0.5 ... 2.5)/2 x (0.5 ... 1.5) 2 x (20 ... 14)						
Connection type		 Spring-type terminals						
<ul style="list-style-type: none"> Solid Finely stranded, with end sleeves acc. to DIN 46228 Finely stranded AWG cables, solid or stranded 	mm ² mm ² mm ² AWG	2 x (0.25 ... 1.5) 2 x (0.25 ... 1.5) 2 x (0.25 ... 1.5) 2 x (24 ... 16)						
Sensor circuit								
Measuring circuit load at $R_F \leq 1.5 \text{ k}\Omega$	mW	≤ 5						
Voltage in sensor circuit at $R_F \leq 1.5 \text{ k}\Omega$	V	≤ 2						
Response temperature (depends on sensor)	°C	60 ... 180						
Coupling time (depends on sensor)	s	About 5						
Summation PTC resistance R_F (per sensor loop) k Ω		≤ 1.5 ; response value 3.4 ... 3.8; return value 1.5 ... 1.65						
Response tolerance	°C	± 6						
Control circuit								
Rated control supply voltage U_s		See pages 10/189 and 10/190						
Operating range		<ul style="list-style-type: none"> 110/230 V AC 24 ... 240 V AC/DC 24 V AC/DC 						
		0.85 ... 1.1 x U_s 0.85 ... 1.1 x U_s 0.85 ... 1.2 x U_s for DC operation, 0.85 ... 1.1 x U_s for AC operation						
Rated power AC/DC	W	< 2						
Auxiliary circuit								
Conventional thermal current I_{th}	A	5						
Rated operational current I_e		<ul style="list-style-type: none"> AC-15/24 ... 250 V DC-13 at <ul style="list-style-type: none"> - 24 V - 125 V - 240 V 						
	A	3						
	A	1						
	A	0.2						
	A	0.1						
DIAZED fuse protection	A	6 ¹⁾						
CSA and UL rated data, control circuit								
Rated control voltage 50/60 Hz		<ul style="list-style-type: none"> AC DC 						
	V	300						
	V	300						
Switching capacity		R 300/B 300						
Protective separation up to 300 V acc. to IEC 60947-1		--			✓ 3RN1013-1BW10, 3RN1013-1GW10		--	

- ✓ Function available
-- Function not available

¹⁾ $I_n > 1 \text{ kA}$ weld-free according to IEC 60947-5-1.

Relays

SIRIUS 3RN1 Thermistor Motor Protection

For PTC sensors

Circuit diagrams

Illustrated with control voltage applied

Illustrated with control voltage not applied

Illustrated with control voltage applied

Illustrated with control voltage not applied

General legend

- A1, A2, A3 Terminals of the control voltage
- N Amplifier
- T/R TEST/RESET button
- Y1, Y2 Terminals for Remote RESET (jumped = Auto RESET)
- ↑ The double arrow indicates an operating state of the contact according to EN 60617-7 which deviates from the norm (here: Position of the contacts when control voltage is applied to terminals A1 and A2)
- H1 LED "READY"
- H2 LED "TRIPPED"
- K Output relay
- T1, T2 Connections of the sensor loop

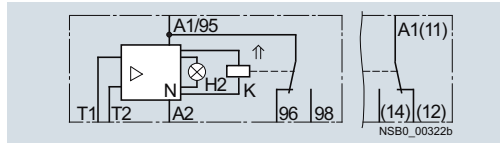

3RN1000, 1 CO

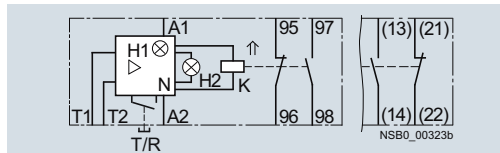

3RN1010, 1 NO + 1 NC

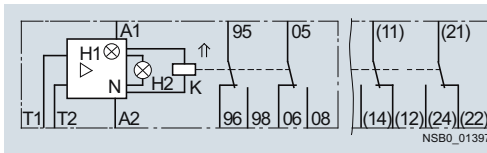

3RN1010, 2 CO

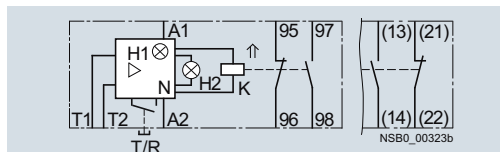

3RN1011¹⁾, 1 NO + 1 NC

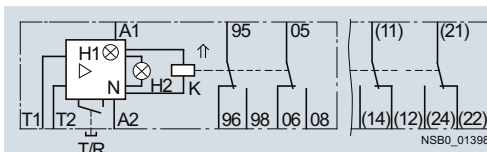

3RN1011, 2 CO

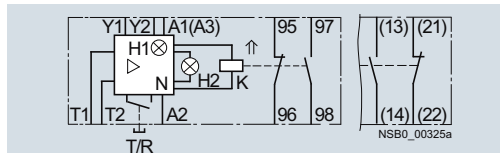

3RN1012¹⁾, 1 NO + 1 NC

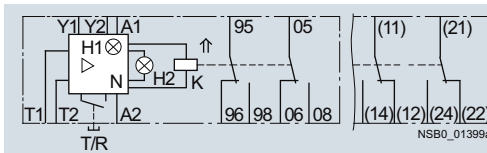

3RN1012, 2 CO

Legend for 3RN1022

- H1 LED "READY"
- H2 LED "TRIPPED"
- H3 LED "ALARM"
- K1 Output relay for warning threshold (LED "ALARM")
- K2 Output relay for disconnect (LED "TRIPPED")
- 1T1 and 2T1 Terminals of the sensor loop
- 2T2 and 1T2 Terminals of the sensor loop

⚠ Important!

Short-circuit unconnected sensor circuits.

Legend for 3RN1062

- H1 to H6 LED of the tripped sensor loop
- H7 LED "READY"
- H8 LED "TRIPPED"
- K Output relay
- 1T1, 1T2 Terminals of the 1st sensor loop
- 6T1, 6T2 Terminals of the 6th sensor loop

⚠ Important!

Short-circuit unconnected sensor circuits.

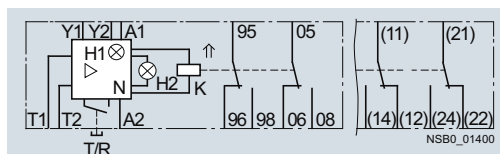

3RN1013-...0 (monostable)

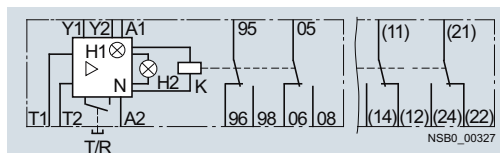

3RN1013-...1 (bistable)

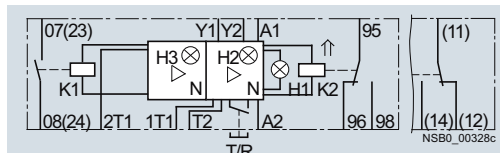

3RN1022

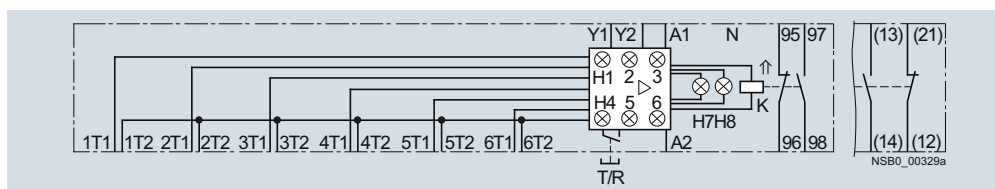



3RN1062

¹⁾ For units with combination voltages 230/110 V AC (3RN1011-.CK00 and 3RN1012-.CK00) A1 and A2 apply: 230 V AC, A3 and A2: 110 V AC.

Selection and ordering data

- For monitoring the motor winding temperature using temperature-dependent resistors (PTCs, type A) that are directly installed in the motor winding by the manufacturer
- Monostable versions with closed-circuit principle, i.e. relays respond in the event of control supply voltage failure
- 3RN1013-.BW01: Bistable version, does not trigger in the event of control supply voltage failure
- All devices have PTB01 ATEX approval for dust or gas
- All devices except for 24 V AC/DC feature electrical separation
- Versions with safe isolation up to 300 V according to IEC 60947-1
- Non-volatile versions
- Versions with short-circuit and open-circuit detection in sensor circuit
- Versions with solid-state compatible, hard gold-plated contacts
- Versions for up to 6 sensor circuits
- Versions with Manual RESET, Remote RESET, Auto RESET and test button
- Terminal labeling according to EN 60947-1
- All terminals are removable
- Width 22.5 mm (45 mm on version for several sensor circuits)

PU (UNIT, SET, M) = 1
 PS* = 1 unit
 PG = 41H

RESET	Contacts	Rated control supply voltage U_s 50/60 Hz	DT	Screw terminals	DT	Spring-type terminals	
				Article No.	Price per PU	Article No.	Price per PU
V							
Compact signal evaluation units, width 22.5 mm, 1 LED							
Terminal A1 is jumpered with the root of the changeover contact							
Auto	1 CO	24 AC/DC 110 AC 230 AC	▶ A ▶	3RN1000-1AB00 3RN1000-1AG00 3RN1000-1AM00	A A A	3RN1000-2AB00 3RN1000-2AG00 3RN1000-2AM00	
Standard evaluation units, width 22.5 mm, 2 LEDs							
	Auto	1 NO + 1 NC	▶ ▶ ▶ ▶	3RN1010-1CB00 3RN1010-1CG00 3RN1010-1CM00 3RN1010-1CW00	▶ A A A	3RN1010-2CB00 3RN1010-2CG00 3RN1010-2CM00 3RN1010-2CW00	
		2 CO	A A A	3RN1010-1BB00 3RN1010-1BG00 3RN1010-1BM00	A C A	3RN1010-2BB00 3RN1010-2BG00 3RN1010-2BM00	
		2 CO, hard gold-plated	A	3RN1010-1GB00	C	3RN1010-2GB00	
3RN1011-1BB00	Manual/Remote ¹⁾	1 NO + 1 NC	▶ ▶	3RN1011-1CB00 3RN1011-1CK00	A A	3RN1011-2CB00 3RN1011-2CK00	
	Short-circuit detection for sensor circuit						
	Manual/Remote ¹⁾	2 CO	A A A	3RN1011-1BB00 3RN1011-1BG00 3RN1011-1BM00	A C A	3RN1011-2BB00 3RN1011-2BG00 3RN1011-2BM00	
		2 CO, hard gold-plated	A	3RN1011-1GB00	A	3RN1011-2GB00	
3RN1012-2CK00	Non-volatile ²⁾						
	Manual/Auto/Remote	1 NO + 1 NC	A A	3RN1012-1CB00 3RN1012-1CK00	A A	3RN1012-2CB00 3RN1012-2CK00	
	Non-volatile ²⁾ , short-circuit detection in sensor circuit						
	Manual/Auto/Remote	2 CO	A C A	3RN1012-1BB00 3RN1012-1BG00 3RN1012-1BM00	C C C	3RN1012-2BB00 3RN1012-2BG00 3RN1012-2BM00	
		2 CO, hard gold-plated	A	3RN1012-1GB00	C	3RN1012-2GB00	
	Non-volatile ²⁾ , short-circuit and open-circuit detection and display in sensor circuit; wide voltage range versions with screw terminal with safe isolation						
3RN1013-1BB00	Manual/Auto/Remote	2 CO	▶ ▶	3RN1013-1BB00 3RN1013-1BW10	A A	3RN1013-2BB00 3RN1013-2BW00	
		2 CO, hard gold-plated	A	3RN1013-1GW10	C	3RN1013-2GW00	
	For bimetal sensors, without short-circuit detection						
Manual/Remote	2 CO	230 V AC	C	3RN1014-1BM00		--	
Bistable evaluation units, width 22.5 mm							
Test/RESET button, non-volatile ²⁾ , short-circuit and open-circuit detection and display in sensor circuit							
Manual/Auto/Remote	2 CO	24 ... 240 AC/DC	▶	3RN1013-1BW01	A	3RN1013-2BW01	

¹⁾ The unit can be reset with the RESET button or by disconnecting the control supply voltage.



²⁾ Protection against voltage failure or non-volatile fault storage means that previous tripping due to a fault remains stored even if the control supply voltage fails. The monitoring device is not reset if the voltage fails. With an active fault, meaning a fault which has not been manually confirmed, an automatic restart of the plant upon recovery of the power is prevented therefore and plant safety increased as the result.

Relays

SIRIUS 3RN1 Thermistor Motor Protection

For PTC sensors

PU (UNIT, SET, M) = 1
 PS* = 1 unit
 PG = 41H





RESET	Contacts	Rated control supply voltage U_s 50/60 Hz	DT	Screw terminals 	DT	Spring-type terminals 	
				Article No.	Price per PU	Article No.	Price per PU
V							
Evaluation units for 2 sensor circuits, warning and disconnection, width 22.5 mm, 3 LEDs							
	Test/RESET button, non-volatile ¹⁾						
	Manual/ 1 NO + 1 CO	24 ... 240 AC/DC	▶	3RN1022-1DW00	A	3RN1022-2DW00	
	Auto/Remote						
Evaluation units for 6 sensor circuits, multiple motor protection, width 45 mm, 8 LEDs							
	Test/RESET button, non-volatile ¹⁾						
	Manual/ 1 NO + 1 NC	24 ... 240 AC/DC	▶	3RN1062-1CW00	A	3RN1062-2CW00	
	Auto/Remote						

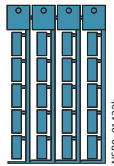

3RN1062-1CW00

¹⁾ Protection against voltage failure or non-volatile fault storage means that previous tripping due to a fault remains stored even if the control supply voltage fails. The monitoring device is not reset if the voltage fails. With an active fault, meaning a fault which has not been manually confirmed, an automatic restart of the plant upon recovery of the power is prevented therefore and plant safety increased as the result.

Accessories

Use	Version	DT	Article No.	Price per PU	PU (UNIT, SET, M)	PS*	PG	
Blank labels								
 NS56_01429B	For 3RN1							
		Unit labeling plates For SIRIUS devices 20 mm x 7 mm, pastel turquoise ¹⁾	D	3RT1900-1SB20		100	340 units	41B
	For 3RN1	Adhesive labels For SIRIUS devices						
			• 19 mm x 6 mm, pastel turquoise	C	3RT1900-1SB60	100	3 060 units	41B
			• 19 mm x 6 mm, zinc yellow	C	3RT1900-1SD60	100	3 060 units	41B
Push-in lugs								
 3RP1903	For 3RN1							
		Push-in lugs For screw fixing, 2 units are required for each device	B	3RP1903		1	10 units	41H
Tools for opening spring-type terminals								
 3RA2908-1A	For auxiliary circuit connections							
		Screwdrivers For all SIRIUS devices with spring-type terminals; 3.0 mm x 0.5 mm; length approx. 200 mm, titanium gray/black, partially insulated	A					
				Spring-type terminals 				
				3RA2908-1A		1	1 unit	41B

¹⁾ PC labeling system for individual inscription of unit labeling plates available from: murrplastik Systemtechnik GmbH, see Chapter 16, "Appendix" → "External Partners".

Overview



SIRIUS 3RS17 interface converters

Interface converters perform the coupling function for analog signals on both the input side and the output side. They are indispensable when processing analog values with electronic controls. Under harsh industrial conditions in particular, it is often necessary to transmit analog signals over long distances. Electrical separation is then needed as a result of the different power supplies. The resistance of the wiring causes potential differences and losses which must be prevented.

Electromagnetic disturbance and overvoltages can affect the signals on the input side in particular or even destroy the analog modules. All terminals of the 3RS17 interface converters are safe up to a voltage of DC 30 V and protected against switching poles. Short-circuit protection is an especially important function for the outputs.

The devices are EMC-tested according to

- IEC 61000-6-4 (basic standard for emitted interference)
- IEC 61000-6-2 (basic standard for interference immunity)

The analog signals comply with

- IEC 60381-1/2

Article No. scheme

Digit of the Article No.	1st - 5th	6th	7th	8th	9th	10th	11th	12th
	□□□□□	□	□	-	□	□	□	□
Interface converters	3 R S 1 7							
Type of input signal		□	□					
Connection methods				□				
Type of output signal					□			
Current type and type of isolation						□		
Measuring range							□	
Example	3 R S 1 7 0 0 - 1 A E 0 0							

Note:

The Article No. scheme is presented here merely for information purposes and for better understanding of the logic behind the article numbers.

For your orders, please use the article numbers quoted in the catalog in the Selection and ordering data.

Application

Converters are used in analog signal processing for

- Electrical separation
- Conversion of normalized and non-normalized signals
- Amplification and impedance adaptation
- Conversion to a frequency for processing by a digital input
- Overvoltage and EMC protection
- Short-circuit protection of the outputs
- Potential duplication

3RS1725 manual/automatic converter

For special applications in which analog signals have to be simulated, or during plant commissioning when the actual process value is not yet available, the 3RS1725 devices feature an adjustable potentiometer for manual setpoint selection and a manual/automatic switch.

The adjustable potentiometer for the 3RS1725 devices is used to simulate analog output signals when the selector switch is set to "manual mode" and the control supply voltage is applied, without the need for an analog input signal; and the scale ranges from 0 to 100 %.

Example: When it is set for an output of 4 to 20 mA, the 0 % scale value on the potentiometer represents an output current of 4 mA and the 100 % scale value represents an output current of 20 mA. In the "Auto" switch position, the output signal follows the input signal proportionally regardless of the potentiometer setting.

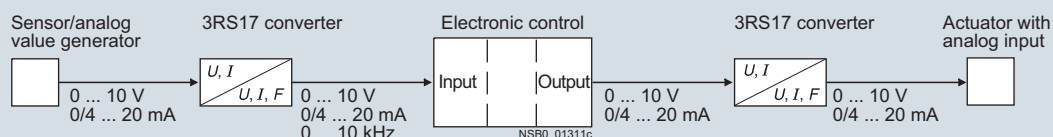

Application example: Interface converter in analog signal evaluation

Relays

Coupling Relays & Interface Converters

SIRIUS 3RS17 interface converters

Technical specifications

Active interface converters

Active interface converters provide maximum flexibility for the application by the use of an external control supply voltage. Configuration with active interface converters is extremely easy because input and output resistances and voltage drops are compensated by the auxiliary supply. They support electrical separation as well as conversion from one signal type to another or reinforcement. The load of the measured value transmitter is negligible.

Passive interface converters

Passive interface converters do not require an external control supply voltage. This advantage can only be used by current signals that are converted 1:1. Reinforcement or conversion is not possible. The converters are used for complete electrical separation of current signals and to protect the inputs and outputs. Passive separators do not operate reaction-free, i.e. any load on the output produces an equal load on the input signal. When the passive converter is to be used, the output power of the sensor and the input resistance of the analog input must be analyzed. This technique is being increasingly implemented in the case of pure current signals.

Calculation guide for passive converters

Important: Please note the following when using passive separators:

The current-driving voltage of the measuring transducer U_E must be sufficient to drive the maximum current of 20 mA over the passive separators with a voltage loss of $U_V = 2.8 \text{ V}$ and the load R_B .

This means that:

$$U_B \geq U_E = 2.8 \text{ V} + 20 \text{ mA} \times R_B$$

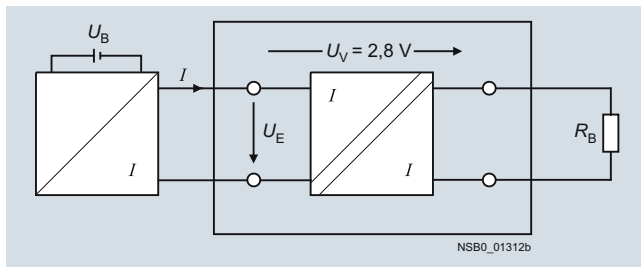

Distribution of the voltages in the case of passive separators

The following figure shows the input voltage U_E as a function of the load R_B taking into account the voltage loss U_V . If the load is known, the y-axis shows the minimum voltage that has to be supplied by the current source in order to drive the maximum current of 20 mA over the passive separator and load.

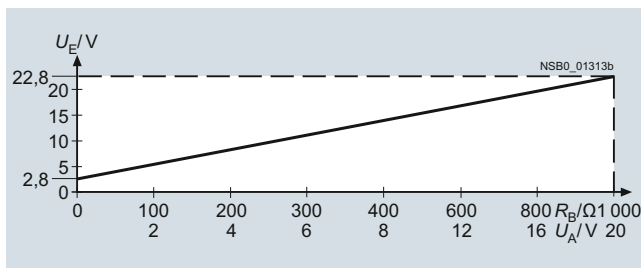

Input voltage depending on the load at $I_a = 20 \text{ mA}$

Load rating of the outputs

A maximum output load is specified for current signals. This resistance value specifies how large the input resistance of the next device connected in series can be as a result of the power of the converter.

For voltage signals, the maximum current that can be drawn from the output is the decisive factor.

2-way separation

In the case of 2-way separation, the input is electrically separated from the output. The "zero potential" of the control supply voltage is the same as the reference potential for the analog output signal.

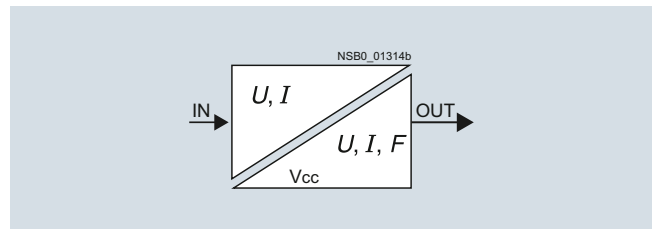



2-way separation

3-way separation

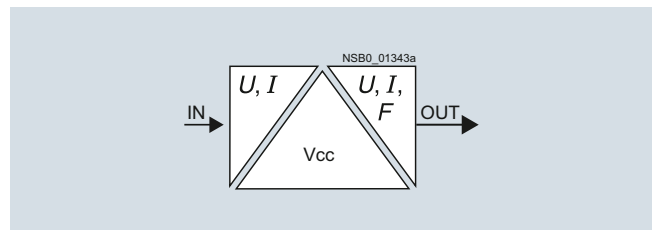
For the 3-way separation, each circuit is electrically separated from the other circuits, i.e. input, output, and control supply voltage do not have equipotential bonding.

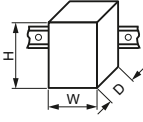

3-way separation

Type 3RS17		24 V AC/DC	24 ... 240 V AC/DC
General data			
Dimensions (W x H x D)		mm	6.2 x 80 x 84
• 3RS1700, 3RS1702, 3RS1703, 3RS1705-.FD, 3RS1705-.FE, 3RS1705-.KD, 3RS1720		mm	6.2 x 90 x 92.5
• 3RS170.-.E00		mm	17.5 x 80 x 84
• 3RS1705-.FW, 3RS1705-.KW, 3RS1706, 3RS1725 • 3RS1721, 3RS1722		mm	12.5 x 80 x 84
Electrical separation of input/output		Active disconnecter: 1500 V, 50 Hz, 1 min; Passive disconnecter: 500 V, 50 Hz, 1 min	4000 V, 50 Hz, 1 min
Rated insulation voltage U_i Pollution degree 2 Overvoltage category III acc. to DIN VDE 0100		V	50
Permissible ambient temperature • During operation		°C	-25 ... +60
Connection type		 Screw terminals	
• Terminal screw • Solid • Finely stranded with end sleeve		mm ² mm ²	M3 0.5 ... 2.5 (AWG 20 ... 14) 0.5 ... 2.5 (AWG 20 ... 14); at 3RS170.-1.E00: 0.5 ... 1.5 (AWG 20 ... 16)
Connection type		 Spring-type terminals	
• Solid • Finely stranded, with end sleeves acc. to DIN 46228 • Finely stranded	Enclosures IEC 529 Terminals IEC 529	mm ² mm ² mm ²	0.5 ... 2.5 (AWG 20 ... 14) 0.5 ... 2.5 (AWG 20 ... 14) 0.5 ... 1.5 (AWG 20 ... 16)
Inputs			
Impedance	Voltage inputs	kΩ	330
	Current inputs, active	Ω	100
Input voltage max.	Voltage inputs	V	30 AC/DC
	Current inputs, active	V	30 AC/DC
Operating currents	Current inputs, passive	μA	100/250 (6.2 mm width)
Voltage drop	Current inputs, passive	V	2.7 at 20 mA
Outputs			
Internal resistance	Voltage output, 0 ... 10 V	Ω	55
Output load	Current 0/4 ... 20 mA active, max.	Ω	400
	Current 0 ... 20 mA passive, max.	Ω	1 000 at 20 mA
	Frequency, min.	Ω	2 400
Output voltage	Frequency	V	20.9
Output current	Voltage output, 0 ... 10 V, max.	mA	21; note the terminating resistor (> 500 Ω)!
	Frequency, max.	mA	10
Short-circuit current	Voltage output, 0 ... 10 V	mA	40
	Current output, 0 ... 20 mA, passive	mA	Corresponds to the input current
	Frequency	mA	15
Protection of the outputs		Short-circuit proof	
Max. overvoltage at output		V	30

Relays

Coupling Relays & Interface Converters

SIRIUS 3RS17 interface converters

Circuit diagrams

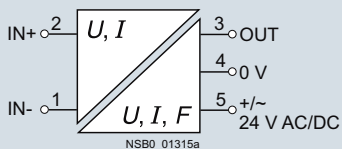

3RS1700-..D.., 3RS1702-..D..,
3RS1703-..D.., 3RS1705-..D..

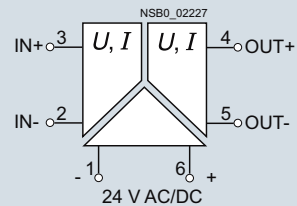

3RS1700-..E00, 3RS1702-..E00,
3RS1703-..E00, 3RS1705-..E00

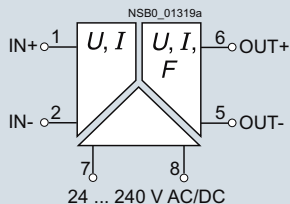

3RS170-..W00

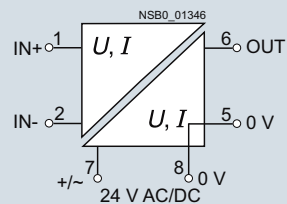

3RS1706-..FD00

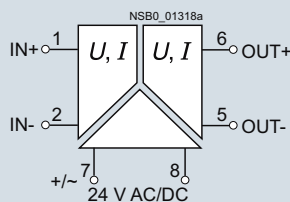

3RS1706-..FE00

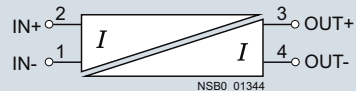

3RS1720-..ET00

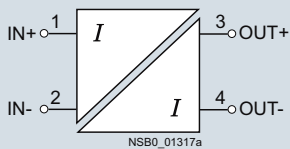

3RS1721-..ET00

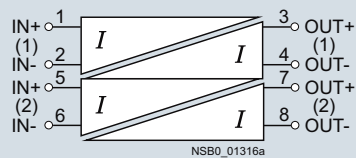

3RS1722-..ET00

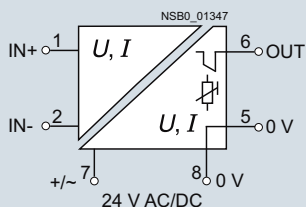

3RS1725-..FD00

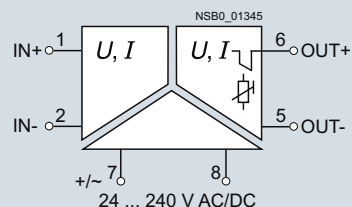

3RS1725-..FW00

10

Selection and ordering data

All transformers except the passive single interface converters have a yellow LED for displaying "Power on".

PU (UNIT, SET, M) = 1
 PS* = 1 unit
 PG = 41H



3RS1706-1FD00



3RS1720-1ET00



3RS1705-2FD00



3RS1705-2FE00



3RS1725-2FD00



Inputs	Outputs	Width mm	Rated control supply voltage U_s V	Electrical separation	DT	Screw terminals		Spring-type terminals	
						Article No.	Price per PU	Article No.	Price per PU
Single interface converters, active									
0 ... 10 V	0 ... 10 V	6.2	24 AC/DC	2 paths	A	3RS1700-1AD00	A	3RS1700-2AD00	
				3 paths	A	3RS1700-1AE00	A	3RS1700-2AE00	
	0 ... 20 mA	6.2	24 AC/DC	2 paths	A	3RS1700-1CD00	A	3RS1700-2CD00	
				3 paths	A	3RS1700-1CE00	A	3RS1700-2CE00	
	4 ... 20 mA	6.2	24 AC/DC	2 paths	A	3RS1700-1DD00	A	3RS1700-2DD00	
				3 paths	A	3RS1700-1DE00	A	3RS1700-2DE00	
0 ... 20 mA	0 ... 10 V	6.2	24 AC/DC	2 paths	A	3RS1702-1AD00	A	3RS1702-2AD00	
				3 paths	A	3RS1702-1AE00	A	3RS1702-2AE00	
	0 ... 20 mA	6.2	24 AC/DC	2 paths	A	3RS1702-1CD00	A	3RS1702-2CD00	
				3 paths	A	3RS1702-1CE00	A	3RS1702-2CE00	
	4 ... 20 mA	6.2	24 AC/DC	2 paths	A	3RS1702-1DD00	A	3RS1702-2DD00	
				3 paths	A	3RS1702-1DE00	A	3RS1702-2DE00	
4 ... 20 mA	0 ... 10 V	6.2	24 AC/DC	2 paths	A	3RS1703-1AD00	A	3RS1703-2AD00	
				3 paths	A	3RS1703-1AE00	A	3RS1703-2AE00	
	0 ... 20 mA	6.2	24 AC/DC	2 paths	A	3RS1703-1CD00	A	3RS1703-2CD00	
				3 paths	A	3RS1703-1CE00	A	3RS1703-2CE00	
	4 ... 20 mA	6.2	24 AC/DC	2 paths	A	3RS1703-1DD00	A	3RS1703-2DD00	
				3 paths	A	3RS1703-1DE00	A	3RS1703-2DE00	
Switchable multi-range converters, active									
0 ... 10 V, 0 ... 20 mA, 4 ... 20 mA, selectable	0 ... 10 V, 0 ... 20 mA, 4 ... 20 mA, selectable	6.2	24 AC/DC	2 paths	A	3RS1705-1FD00	A	3RS1705-2FD00	
				3 paths	A	3RS1705-1FE00	A	3RS1705-2FE00	
		17.5	24 ... 240 AC/DC	3 paths	A	3RS1705-1FW00	A	3RS1705-2FW00	
0 ... 10 V, 0 ... 20 mA, 4 ... 20 mA, selectable	0 ... 50 Hz, 0 ... 100 Hz, 0 ... 1 kHz, 0 ... 10 kHz, selectable	6.2	24 AC/DC	2 paths	A	3RS1705-1KD00	A	3RS1705-2KD00	
				17.5	24 ... 240 AC/DC	3 paths	A	3RS1705-1KW00	A
Switchable universal converters, active, with 16 input ranges and 3 output ranges									
0 ... 60 mV, 0 ... 100 mV, 0 ... 300 mV, 0 ... 500 mV, 0 ... 1 V, 0 ... 2 V, 0 ... 5 V, 0 ... 10 V, 0 ... 20 V, 2 ... 10 V, 0 ... 5 mA, 0 ... 10 mA, 0 ... 20 mA, 4 ... 20 mA, +/-5 mA, +/-20 mA, selectable	0 ... 10 V, 0 ... 20 mA, 4 ... 20 mA, selectable	17.5	24 AC/DC	2 paths	A	3RS1706-1FD00	A	3RS1706-2FD00	
				3 paths	A	3RS1706-1FE00	A	3RS1706-2FE00	
		24 ... 240 AC/DC	3 paths	A	3RS1706-1FW00	A	3RS1706-2FW00		
Switchable multi-range converters, active, with manual/automatic switch and single potentiometer as manual analog signal transmitter									
0 ... 10 V, 0 ... 20 mA, 4 ... 20 mA, selectable	0 ... 10 V, 0 ... 20 mA, 4 ... 20 mA, selectable	17.5	24 AC/DC	2 paths	A	3RS1725-1FD00	A	3RS1725-2FD00	
				3 paths	A	3RS1725-1FW00	A	3RS1725-2FW00	
		24 ... 240 AC/DC	3 paths	A	3RS1725-1FW00	A	3RS1725-2FW00		

Relays





Coupling Relays & Interface Converters

SIRIUS 3RS17 interface converters

PU (UNIT, SET, M) = 1
 PS* = 1 unit
 PG = 41H

Inputs	Outputs	Width mm	Number of channels	Electrical separation	DT	Screw terminals 		Spring-type terminals 	
						Article No.	Price per PU	Article No.	Price per PU
Single interface converters, passive									
0/4 ... 20 mA	0/4 ... 20 mA	6.2	1	2 paths	A	3RS1720-1ET00	A	3RS1720-2ET00	
		12.5	1	2 paths	A	3RS1721-1ET00	A	3RS1721-2ET00	
			2	2 paths	A	3RS1722-1ET00	A	3RS1722-2ET00	

Accessories

Use	Version	DT	Article No.	Price per PU	PU (UNIT, SET, M)	PS*	PG
Tools for opening spring-type terminals							
 For auxiliary circuit connections	Screwdrivers For all SIRIUS devices with spring-type terminals; 3.0 mm x 0.5 mm, length approx. 200 mm, titanium gray/black, partially insulated	A	Spring-type terminals  3RA2908-1A		1	1 unit	41B
Connecting combs, blue							
 For 3RS17...-E00	Connecting combs For linking the same potentials, 16 terminals, current carrying capacity for infeed max. 6 A	A	3TX7014-7AA00		1	5 units	41H
Galvanic isolation plates							
 For 3RS17...-E00	Galvanic isolation plates	A	3TX7014-7CE00		1	10 units	41H