

Power contactor, AC-3 400 A, 200 kW / 400 V Coil AC 50/60 Hz and DC 200-277 V x (0.8-1.1) F-PLC input 24 V DC 3-pole size S12
 Auxiliary contacts 2 NO + 2 NC cannot be dissolved (SUVA) Main circuit: Busbar Control and auxiliary circuit: screw terminal



Product brand name	SIRIUS
Product designation	Power contactor
Product type designation	3RT1
General technical data	
Size of contactor	S12
Product extension	
• function module for communication	No
• Auxiliary switch	Yes
Power loss [W] for rated value of the current	
• at AC in hot operating state	105 W
• at AC in hot operating state per pole	35 W
Power loss [W] for rated value of the current without load current share typical	3.6 W
Surge voltage resistance	
• of main circuit rated value	8 kV
• of auxiliary circuit rated value	6 kV
maximum permissible voltage for safe isolation	
• between coil and main contacts acc. to EN 60947-1	690 V

Protection class IP	IP00; IP20 on the front with cover / box terminal IP00
<ul style="list-style-type: none"> • on the front • of the terminal 	
Shock resistance at rectangular impulse	8,5g / 5 ms, 4,2g / 10 ms
<ul style="list-style-type: none"> • at AC • at DC 	8,5g / 5 ms, 4,2g / 10 ms
Shock resistance with sine pulse	13,4g / 5 ms, 6,5g / 10 ms
<ul style="list-style-type: none"> • at AC • at DC 	13,4g / 5 ms, 6,5g / 10 ms
Mechanical service life (switching cycles)	
<ul style="list-style-type: none"> • of contactor typical 	10 000 000
<ul style="list-style-type: none"> • of the contactor with added electronics-compatible auxiliary switch block typical 	5 000 000
<ul style="list-style-type: none"> • of the contactor with added auxiliary switch block typical 	10 000 000
Reference code acc. to DIN 40719 extended according to IEC 204-2 acc. to IEC 750	K
Reference code acc. to DIN EN 81346-2	Q

Ambient conditions

Installation altitude at height above sea level	2 000 m
<ul style="list-style-type: none"> • maximum 	
Ambient temperature	-25 ... +60 °C
<ul style="list-style-type: none"> • during operation • during storage 	-55 ... +80 °C

Main circuit

Number of poles for main current circuit	3
Number of NO contacts for main contacts	3
Operating voltage	1 000 V
<ul style="list-style-type: none"> • at AC-3 rated value maximum 	
Operating current	
<ul style="list-style-type: none"> • at AC-1 at 400 V <ul style="list-style-type: none"> — at ambient temperature 40 °C rated value • at AC-1 <ul style="list-style-type: none"> — up to 690 V at ambient temperature 40 °C rated value — up to 690 V at ambient temperature 60 °C rated value — up to 1000 V at ambient temperature 40 °C rated value — up to 1000 V at ambient temperature 60 °C rated value • at AC-2 at 400 V rated value 	430 A 430 A 400 A 200 A 200 A 400 A

<ul style="list-style-type: none"> • at AC-3 <ul style="list-style-type: none"> — at 400 V rated value — at 500 V rated value — at 690 V rated value — at 1000 V rated value • at AC-4 at 400 V rated value • at AC-5a up to 690 V rated value • at AC-5b up to 400 V rated value • at AC-6a <ul style="list-style-type: none"> — up to 230 V for current peak value n=20 rated value — up to 400 V for current peak value n=20 rated value — up to 500 V for current peak value n=20 rated value — up to 690 V for current peak value n=20 rated value — up to 1000 V for current peak value n=20 rated value • at AC-6a <ul style="list-style-type: none"> — up to 230 V for current peak value n=30 rated value — up to 400 V for current peak value n=30 rated value — up to 500 V for current peak value n=30 rated value — up to 690 V for current peak value n=30 rated value — up to 1000 V for current peak value n=30 rated value 	<p>400 A</p> <p>400 A</p> <p>400 A</p> <p>180 A</p> <p>350 A</p> <p>378 A</p> <p>332 A</p> <p>377 A</p> <p>377 A</p> <p>377 A</p> <p>377 A</p> <p>180 A</p> <p>251 A</p> <p>251 A</p> <p>251 A</p> <p>251 A</p> <p>180 A</p>
Minimum cross-section in main circuit	
<ul style="list-style-type: none"> • at maximum AC-1 rated value 	300 mm ²
Operating current for approx. 200000 operating cycles at AC-4	
<ul style="list-style-type: none"> • at 400 V rated value • at 690 V rated value 	<p>150 A</p> <p>135 A</p>
Operating current	
<ul style="list-style-type: none"> • at 1 current path at DC-1 <ul style="list-style-type: none"> — at 24 V rated value — at 110 V rated value — at 220 V rated value — at 440 V rated value — at 600 V rated value 	<p>400 A</p> <p>33 A</p> <p>3.8 A</p> <p>0.9 A</p> <p>0.6 A</p>

<ul style="list-style-type: none"> • with 2 current paths in series at DC-1 <ul style="list-style-type: none"> — at 24 V rated value — at 110 V rated value — at 220 V rated value — at 440 V rated value — at 600 V rated value • with 3 current paths in series at DC-1 <ul style="list-style-type: none"> — at 24 V rated value — at 110 V rated value — at 220 V rated value — at 440 V rated value — at 600 V rated value 	<p>400 A</p> <p>400 A</p> <p>400 A</p> <p>4 A</p> <p>2 A</p> <p>400 A</p> <p>400 A</p> <p>400 A</p> <p>11 A</p> <p>5.2 A</p>
Operating current	
<ul style="list-style-type: none"> • at 1 current path at DC-3 at DC-5 <ul style="list-style-type: none"> — at 24 V rated value — at 110 V rated value — at 220 V rated value — at 440 V rated value — at 600 V rated value • with 2 current paths in series at DC-3 at DC-5 <ul style="list-style-type: none"> — at 24 V rated value — at 110 V rated value — at 220 V rated value — at 440 V rated value — at 600 V rated value • with 3 current paths in series at DC-3 at DC-5 <ul style="list-style-type: none"> — at 24 V rated value — at 110 V rated value — at 220 V rated value — at 440 V rated value — at 600 V rated value 	<p>400 A</p> <p>3 A</p> <p>0.6 A</p> <p>0.18 A</p> <p>0.125 A</p> <p>400 A</p> <p>400 A</p> <p>2.5 A</p> <p>0.65 A</p> <p>0.37 A</p> <p>400 A</p> <p>400 A</p> <p>400 A</p> <p>1.4 A</p> <p>0.75 A</p>
Operating power	
<ul style="list-style-type: none"> • at AC-1 <ul style="list-style-type: none"> — at 230 V at 60 °C rated value — at 400 V rated value — at 400 V at 60 °C rated value — at 690 V rated value — at 690 V at 60 °C rated value — at 1000 V at 60 °C rated value • at AC-2 at 400 V rated value • at AC-3 	<p>151 kW</p> <p>263 kW</p> <p>263 kW</p> <p>430 kW</p> <p>454 kW</p> <p>329 kW</p> <p>200 kW</p>

— at 230 V rated value	132 kW
— at 400 V rated value	200 kW
— at 500 V rated value	250 kW
— at 690 V rated value	400 kW
— at 1000 V rated value	250 kW
Operating power for approx. 200000 operating cycles at AC-4	
• at 400 V rated value	85 kW
• at 690 V rated value	133 kW
Short-time withstand current in cold operating state up to 40 °C	
• limited to 1 s switching at zero current maximum	6 600 A; Use minimum cross-section acc. to AC-1 rated value
• limited to 5 s switching at zero current maximum	5 761 A; Use minimum cross-section acc. to AC-1 rated value
• limited to 10 s switching at zero current maximum	4 143 A; Use minimum cross-section acc. to AC-1 rated value
• limited to 30 s switching at zero current maximum	2 635 A; Use minimum cross-section acc. to AC-1 rated value
• limited to 60 s switching at zero current maximum	2 088 A; Use minimum cross-section acc. to AC-1 rated value
No-load switching frequency	
• at AC	500 1/h
• at DC	500 1/h
Operating frequency	
• at AC-1 maximum	350 1/h
• at AC-2 maximum	200 1/h
• at AC-3 maximum	350 1/h
• at AC-4 maximum	130 1/h
Control circuit/ Control	
Type of voltage of the control supply voltage	AC/DC
Control supply voltage at AC	
• at 50 Hz rated value	200 ... 277 V
• at 60 Hz rated value	200 ... 277 V
Control supply voltage at DC	
• rated value	200 ... 277 V
Type of PLC-control input acc. to IEC 60947-1	Type 1
Consumed current at PLC-control input acc. to IEC 60947-1 maximum	14 mA
Voltage at PLC-control input rated value	24 V
Operating range factor of the voltage at PLC-control input	0.8 ... 1.1

Operating range factor control supply voltage rated value of magnet coil at DC	
• initial value	0.8
• Full-scale value	1.1
Operating range factor control supply voltage rated value of magnet coil at AC	
• at 50 Hz	0.8 ... 1.1
• at 60 Hz	0.8 ... 1.1
Design of the surge suppressor	with varistor
Apparent pick-up power of magnet coil at AC	
• at 50 Hz	750 V·A
Inductive power factor with closing power of the coil	
• at 50 Hz	0.8
Apparent holding power of magnet coil at AC	
• at 50 Hz	7 V·A
Inductive power factor with the holding power of the coil	
• at 50 Hz	0.8
Closing power of magnet coil at DC	800 W
Holding power of magnet coil at DC	3.6 W
Closing delay	
• at AC	60 ... 75 ms
• at DC	60 ... 75 ms
Opening delay	
• at AC	115 ... 130 ms
• at DC	115 ... 130 ms
Recovery time after power failure typical	2 s
Arcing time	10 ... 15 ms
Control version of the switch operating mechanism	Fail-safe PLC input (F-PLC-IN)

Auxiliary circuit

Number of NC contacts for auxiliary contacts	
• instantaneous contact	2
Number of NO contacts for auxiliary contacts	
• instantaneous contact	2
Operating current at AC-12 maximum	10 A
Operating current at AC-15	
• at 230 V rated value	6 A
• at 400 V rated value	3 A
• at 500 V rated value	2 A
• at 690 V rated value	1 A
Operating current at DC-12	
• at 24 V rated value	10 A

<ul style="list-style-type: none"> • at 48 V rated value • at 60 V rated value • at 110 V rated value • at 125 V rated value • at 220 V rated value • at 600 V rated value 	<p>6 A</p> <p>6 A</p> <p>3 A</p> <p>2 A</p> <p>1 A</p> <p>0.15 A</p>
Operating current at DC-13	
<ul style="list-style-type: none"> • at 24 V rated value • at 48 V rated value • at 60 V rated value • at 110 V rated value • at 125 V rated value • at 220 V rated value • at 600 V rated value 	<p>10 A</p> <p>2 A</p> <p>2 A</p> <p>1 A</p> <p>0.9 A</p> <p>0.3 A</p> <p>0.1 A</p>
Contact reliability of auxiliary contacts	1 faulty switching per 100 million (17 V, 1 mA)

UL/CSA ratings

Full-load current (FLA) for three-phase AC motor	
<ul style="list-style-type: none"> • at 480 V rated value • at 600 V rated value 	<p>361 A</p> <p>382 A</p>
Yielded mechanical performance [hp]	
<ul style="list-style-type: none"> • for three-phase AC motor <ul style="list-style-type: none"> — at 200/208 V rated value — at 220/230 V rated value — at 460/480 V rated value — at 575/600 V rated value 	<p>125 hp</p> <p>150 hp</p> <p>300 hp</p> <p>400 hp</p>
Contact rating of auxiliary contacts according to UL	A600 / P600

Short-circuit protection

Design of the fuse link	
<ul style="list-style-type: none"> • for short-circuit protection of the main circuit <ul style="list-style-type: none"> — with type of coordination 1 required — with type of assignment 2 required • for short-circuit protection of the auxiliary switch required 	<p>gG: 630 A (690 V, 100 kA)</p> <p>gG: 500 A (690 V, 100 kA), aM: 400 A (690 V, 50 kA), BS88: 450 A (415 V, 50 kA)</p> <p>gG: 10 A (500 V, 1 kA)</p>

Installation/ mounting/ dimensions

Mounting position	with vertical mounting surface +/-90° rotatable, with vertical mounting surface +/- 22.5° tiltable to the front and back
Mounting type	screw fixing
<ul style="list-style-type: none"> • Side-by-side mounting 	Yes
Height	214 mm
Width	160 mm

Depth	225 mm
Required spacing	
<ul style="list-style-type: none"> • with side-by-side mounting <ul style="list-style-type: none"> — forwards 20 mm — upwards 10 mm — downwards 10 mm — at the side 0 mm • for grounded parts <ul style="list-style-type: none"> — forwards 20 mm — upwards 10 mm — at the side 10 mm — downwards 10 mm • for live parts <ul style="list-style-type: none"> — forwards 20 mm — upwards 10 mm — downwards 10 mm — at the side 10 mm 	

Connections/ Terminals	
Width of connection bar	25 mm
Thickness of connection bar	6 mm
Diameter of holes	11 mm
Number of holes	1
Type of electrical connection	
<ul style="list-style-type: none"> • for main current circuit • for auxiliary and control current circuit • at contactor for auxiliary contacts • of magnet coil 	Connection bar screw-type terminals Screw-type terminals Screw-type terminals
Type of connectable conductor cross-sections	
<ul style="list-style-type: none"> • at AWG conductors for main contacts 	2/0 ... 500 kcmil
Connectable conductor cross-section for main contacts	
<ul style="list-style-type: none"> • stranded 	70 ... 240 mm ²
Connectable conductor cross-section for auxiliary contacts	
<ul style="list-style-type: none"> • single or multi-stranded • finely stranded with core end processing 	0.5 ... 4 mm ² 0.5 ... 2.5 mm ²
Type of connectable conductor cross-sections	
<ul style="list-style-type: none"> • for auxiliary contacts <ul style="list-style-type: none"> — solid — single or multi-stranded — finely stranded with core end processing • at AWG conductors for auxiliary contacts 	2x (0.5 ... 1.5 mm ²), 2x (0.75 ... 2.5 mm ²), max. 2x (0.75 ... 4 mm ²) 2x (0,5 ... 1,5 mm ²), 2x (0,75 ... 2,5 mm ²), max. 2x (0,75 ... 4 mm ²) 2x (0.5 ... 1.5 mm ²), 2x (0.75 ... 2.5 mm ²) 2x (20 ... 16), 2x (18 ... 14), 1x 12

AWG number as coded connectable conductor cross section	
<ul style="list-style-type: none"> • for auxiliary contacts 	18 ... 14

Safety related data

Safety device type acc. to IEC 61508-2	Type B
B10 value	
<ul style="list-style-type: none"> • with high demand rate acc. to SN 31920 	1 000 000
Safety Integrity Level (SIL) acc. to IEC 61508	2
SIL Claim Limit (subsystem) acc. to EN 62061	2
Performance level (PL) acc. to EN ISO 13849-1	c
Category acc. to EN ISO 13849-1	2
Stop category acc. to DIN EN 60204-1	0
Product function	
<ul style="list-style-type: none"> • Mirror contact acc. to IEC 60947-4-1 	Yes
<ul style="list-style-type: none"> • positively driven operation acc. to IEC 60947-5-1 	No
PFHD with high demand rate acc. to EN 62061	0.00000045 1/h
PFDavg with low demand rate acc. to IEC 61508	0.007
MTBF	75 y
Hardware fault tolerance acc. to IEC 61508	0
T1 value for proof test interval or service life acc. to IEC 61508	20 y
Protection against electrical shock	finger-safe when touched vertically from front acc. to IEC 60529

Certificates/ approvals

General Product Approval	EMC	Functional Safety/Safety of Machinery
--------------------------	-----	---------------------------------------



[Type Examination Certificate](#)

Declaration of Conformity	Test Certificates	other
---------------------------	-------------------	-------



[Miscellaneous](#)

[Special Test Certificate](#)

[Type Test Certificates/Test Report](#)

[Confirmation](#)

[Miscellaneous](#)

Railway

[Special Test Certificate](#)

Further information

Information- and Downloadcenter (Catalogs, Brochures,...)

www.siemens.com/ic10

Industry Mall (Online ordering system)

<https://mall.industry.siemens.com/mall/en/en/Catalog/product?mlfb=3RT1075-6SP36-3PA0>

Cax online generator

<http://support.automation.siemens.com/WW/CAXorder/default.aspx?lang=en&mlfb=3RT1075-6SP36-3PA0>

Service&Support (Manuals, Certificates, Characteristics, FAQs,...)

<https://support.industry.siemens.com/cs/ww/en/ps/3RT1075-6SP36-3PA0>

Image database (product images, 2D dimension drawings, 3D models, device circuit diagrams, EPLAN macros, ...)

http://www.automation.siemens.com/bilddb/cax_de.aspx?mlfb=3RT1075-6SP36-3PA0&lang=en

Characteristic: Tripping characteristics, I²t, Let-through current

<https://support.industry.siemens.com/cs/ww/en/ps/3RT1075-6SP36-3PA0/char>

Further characteristics (e.g. electrical endurance, switching frequency)

<http://www.automation.siemens.com/bilddb/index.aspx?view=Search&mlfb=3RT1075-6SP36-3PA0&objecttype=14&gridview=view1>

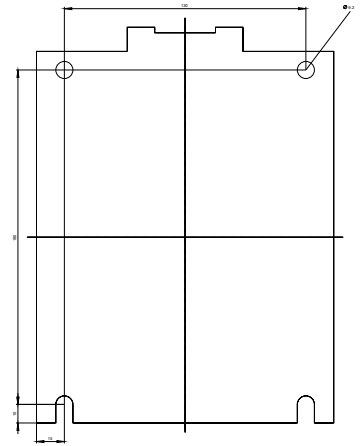
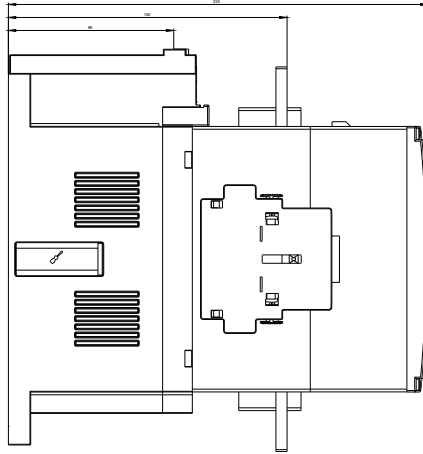
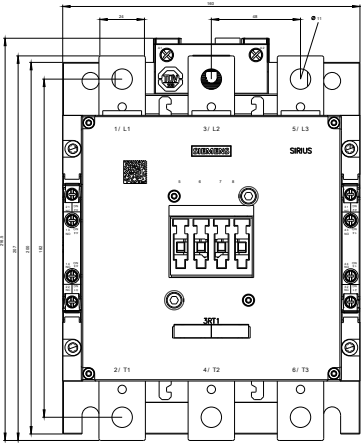

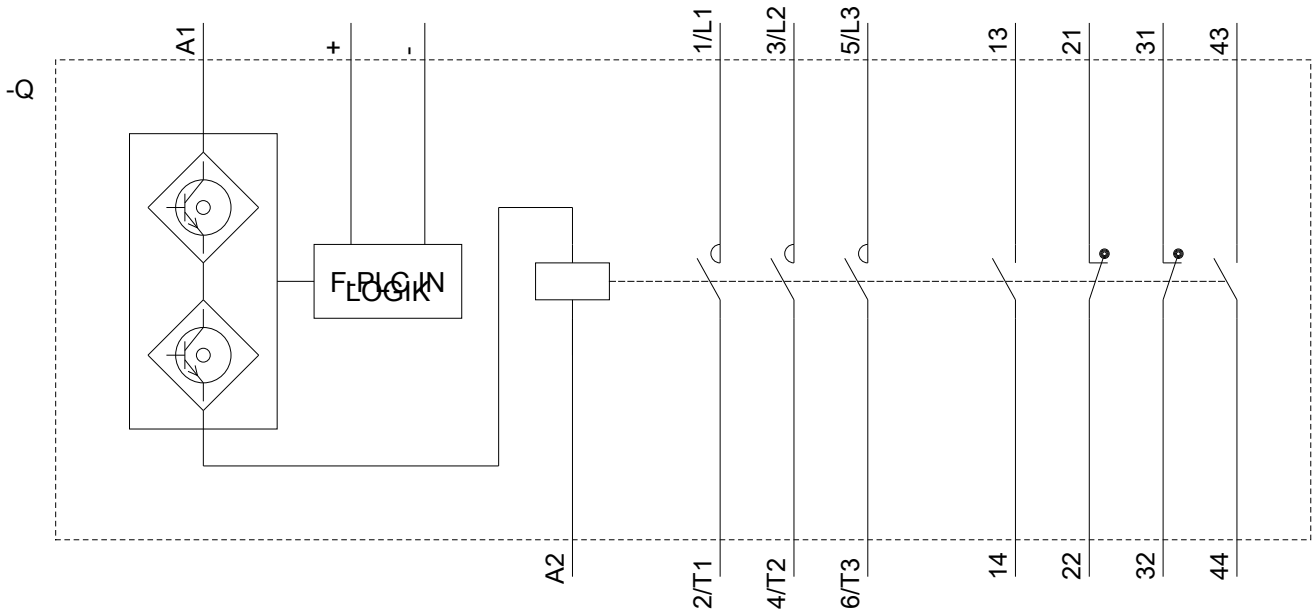

last modified:

01/28/2020