

The Siemens logo is displayed in a bold, teal, sans-serif font. It is positioned in the upper left corner of the page, set against a white rectangular background. The background of the entire page is a photograph of a dense forest with tall, thin trees and vibrant green foliage, with sunlight filtering through the leaves, creating a bright and natural atmosphere.

SIEMENS

Ingenuity for life

Supplement to
SPEEDFAX™ Catalog Section 8

Low Voltage Transformers with DOE 2016 updates

Including Series H and
Series J Addendums

usa.siemens.com/distribution-transformers

Contents

Speedfax Section 8

See page 8-1 for Table of Contents	8-1 – 8-27
------------------------------------	------------

H Series Transformers

Series H Data Charts	H-2 – H-9
Wiring Diagrams	H-11 – H-14
Enclosure Drawings	H-15 – H-16
Termination Details	H-17
Typical Performance Data	H-18 – H-25

J Series Transformers

Aluminum K1 3-Phase Delta Primary Series J	J-4 – J-6
Aluminum K4 3-Phase Delta Primary Series J	J-7 – J-9
Aluminum K13 3-Phase Delta Primary Series J	J-10 – J-12
Aluminum K20 3-Phase Delta Primary Series J	J-13 – J-15
Copper K1 3-Phase Delta Primary Series J	J-16 – J-18
Copper K4 3-Phase Delta Primary Series J	J-19 – J-21
Copper K13 3-Phase Delta Primary Series J	J-22 – J-24
Copper K20 3-Phase Delta Primary Series J	J-25 – J-27
T-Wiring Diagrams	J-28 – J-33
Typical Performance Data	J-34 – J-38



Sentron Power Centers

Contents

Transformer—Dry Type Distribution	8-2 - 8-3
Features and Technical Information	8-4
Catalog Coding System	8-5 - 8-8
Single Phase—Distribution Dry Type	8-9 - 8-10
Three Phase—Distribution Dry Type	8-11 - 8-14
Filtered Isolation and Motor Drive	8-15
Sentron Power Centers	8-16 - 8-17
High Efficiency Transformers	8-18
Harmonic Mitigation Transformers	8-19 - 8-20
Buck-Boost Transformers	
Buck-Boost Application, Selection Tables	8-21 - 8-24
Buck Boost Single Phase and Three Phase Connection Diagrams	8-25 - 8-26
Accessories for Transformers: Lugs, Drip Shields and Wall Brackets	8-27

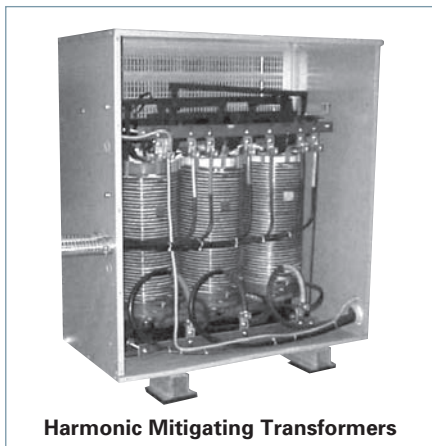

Harmonic Mitigating Transformers



Buck-Boost Transformers

Scan to connect online to the most up-to-date version of this Section of SPEEDFAX.



Transformers

Dry Type Distribution 600 Volt Class^①

General

Siemens dry type distribution transformers are rated 600 volt class and are available in a wide variety of ratings to provide versatile electrical distribution for general purpose, lighting and power loads in commercial and industrial applications.

Ratings are available from 0.25 through 167 kVA single phase, and 3 through 1000 kVA 3-phase. A variety of primary and secondary voltage ratings are available to match the load requirements to the distribution system. All units meet applicable ANSI and NEMA standards. Standard designs are UL Listed. Transformers are designed, manufactured, and tested in accordance with ANSI, NEMA and IEEE Standards and are UL Listed. All units are fungus resistant. Fungus proof is not an option.



Encapsulated Transformer



Ventilated Transformer

Encapsulated

- The self-cooled kVA rating shall be suitable for 30°C average, 40°C maximum ambient temperature.
- Ratings from 0.25 kVA through 25 kVA, 1-phase, and from 3 kVA through 15 kVA 3-phase are available.
- Feature indoor/outdoor enclosures with integral wall mounting brackets, and either a 135°C rise, 180°C insulation system or a 95°C rise, 130°C insulation system.

Ventilated

- Ratings from 15 kVA through 167 kVA 1-phase, and from 15 kVA through 1000 kVA 3-phase are available.
- Indoor NEMA 1/3R enclosures with 150oC rise and 220oC insulation systems are standard. Many options are available.②
- Most three phase designs (15 kVA through 75kVA) and single phase designs (15 kVA through 50kVA)

- include primary and secondary terminal lugs. For more information, refer to lug table on page 8-8. Call customer support for confirmation if needed.
- 1-phase up to 167 kVA and 3-phase up to 750kVA are Seismic certified for floor mounting. Call customer support for larger kVA certification or wall mounting applications.

DOE 2016 Efficiency Standards

- Department of Energy (DOE) 10 CFR 431 released efficiency standards which will take effect January 1, 2016.
- New efficiency standards apply to dry-type three-phase ventilated transformers, including Harmonic Mitigating Transformers from 15 kVA to 1000kVA
- New standards will surpass and supersede NEMA TP1 standards and will make NEMA Premium obsolete.
- DOE 2016 designs have grain-oriented, non-aging silicon steel.
- Dry type, three phase ventilated transformers must be manufactured to DOE 2016 standards after January 1, 2016
- NEMA TP1 rated transformers will still be available for single phase transformers after January 1, 2016
- See accompanying chart for efficiency increases for DOE 2016 standards.

Comparison of 3-Phase LV Transformer Efficiency

kVA	TP1	NEMA Premium ^①	DOE 2016
15	97.00%	97.90%	97.89%
30	97.50%	98.25%	98.23%
45	97.70%	98.39%	98.40%
75	98.00%	98.60%	98.60%
112.5	98.20%	98.74%	98.74%
150	98.30%	98.81%	98.83%
225	98.50%	98.95%	98.94%
300	98.60%	99.02%	99.02%
500	98.70%	99.09%	99.14%
750	98.80%	99.16%	99.23%
1000	98.90%	99.23%	99.28%

①NEMA Premium will no longer be available after January 1, 2016 due to DOE 2016 requirements.

Distribution Dry Type Transformers

600 Volts Class — Single and Three Phase

Selection

600 Volts Class
Single Phase 0.25-167 kVA
Three Phase 3-1000 kVA

Features

- Standard units are UL listed and are designed in accordance with ANSI, NEMA (ST20) and IEEE standards

Encapsulated

- UL listed designs (UL 506)
- Totally enclosed, non-ventilated, heavy gauge steel enclosure
- Core and coil completely embedded within a resin compound for quiet, low temperature operation
- Encapsulation seals out moisture and air
- UL listed indoor/outdoor enclosure features integral wall mounting brackets
- Rugged design resists weather, dust, and corrosion
- Efficient, compact, lightweight, easy to install
- Flexible wiring leads that terminate within the bottom wiring compartment
- Large wiring compartment on the bottom with convenient knockouts
- High quality non-aging electrical grade core steel
- Precision wound coils

Ventilated

- UL listed designs (UL 1561)
- Designed for indoor NEMA 2 installations. NEMA 3R enclosures suitable for outdoor locations available as an option
- All D16 catalog numbers include NEMA 3R enclosures as standard unless other options chosen change or remove the enclosure
- Core and coils are designed with UL listed high-temperature materials rated for 220°C; standard units feature 150°C winding temperature rise
- Optional low temperature rise of 115° C or 80° C winding temperature rise for increased efficiency and additional over-load capability
- Rugged sheet steel enclosure per UL1561, UL506 standards with removable panels for access to the internal wiring area
- Neoprene noise dampening pads isolate the core and coil from the enclosure
- Optional drip shields/weathershield and wall brackets available
- High quality grain-oriented, non-aging silicon steel core for 3 Phase units

Single Phase Transformer Ampere Ratings

Single Phase Full Load Amperes (FLC)						
kVA	120V	208V	240V	277V	480V	600V
0.25	2.0	1.2	1.0	0.9	0.5	0.4
0.50	4.2	2.4	2.1	1.8	1.0	0.8
0.75	6.3	3.6	3.1	2.7	1.6	1.3
1	8.3	4.8	4.2	3.6	2.1	1.7
1.5	12.5	7.2	6.2	5.4	3.1	2.5
2	16.7	9.6	8.3	7.2	4.2	3.3
3	25	14.4	12.5	10.8	6.2	5
5	41	24	20.8	18.0	10.4	8.3
7.5	62	36	31	27	15.3	12.5
10	83	48	41	36	20.8	16.7
15	125	72	62	54	31	25
25	206	120	104	90	52	41
37.5	312	180	156	135	76	62
50	416	240	208	180	104	83
75	625	340	312	270	156	125
100	833	480	416	361	208	166
167	1391	803	695	603	347	278

Three Phase Transformer Ampere Ratings

Three Phase Full Load Amperes (FLC)				
kVA	208V	240V	480V	600V
3	8.3	7.2	3.6	2.9
6	16.6	14.4	7.2	5.8
9	25	21.6	10.8	8.6
15	41.7	36.1	18.0	14.4
30	83.4	72.3	36.1	28.9
45	124	108	54.2	43.4
75	208	180	90	72
112.5	312	270	135	108
150	416	360	180	144
225	624	541	270	216
300	832	721	360	288
500	1387	1202	601	481
750	2084	1806	903	723
1000	2779	2408	1204	963

Insulation Class and Temperature Rise[Ⓞ]

kVA		Insulation	
1-Phase	3-Phase	Temperature Class	Temperature Rise
0.25-1	N/A	130° C	95° C
1.5-25	3-15	180° C	135° C
15-167	15-1000	220° C	150° C

Sound Level in Decibels – 600V Class

kVA	Self Cooled Ventilated		Self Cooled Sealed	kVA	Self Cooled Ventilated		Self Cooled Sealed
	K Factor: 1, 4, 9	K Factor: 13, 20			K Factor: 1, 4, 9	K Factor: 13, 20	
NEMA Average DB				NEMA Average DB			
0-3.00	40	40	45	112.51-150.00	50	53	55
3.01-9.00	40	40	45	150.01-225.00	55	58	57
9.01-15.00	45	45	50	225.01-300.00	55	58	57
15.01-30.00	45	45	50	300.01-500.00	60	63	59
30.01-50.00	45	48	50	500.01-700.00	62	65	61
50.01-75.00	50	53	55	700.01-1000.00	64	67	63
75.01-112.50	50	53	55				

[Ⓞ] Temp rise and insulation system values shown are typical. Variation in these values may exist depending on size, design and series. but will comply with the requirements of UL506 and UL1561

Transformers

Dry Type Distribution 600 Volt Class^①

Specifications

Standard Construction Features

Transformers rated 15 kVA and larger shall be a ventilated dry type with a UL Listed 220°C insulation system. Units shall be designed to operate with a rated maximum temperature rise of 150°C (Optional 115°C or 80°C rise can be specified).

Construction shall consist of aluminum windings and arranged to brace coil layers and provide maximum ventilation. (Optional copper windings can be specified). 3-Phase cores shall be constructed of grain-oriented, non-aging silicon steel with high magnetic permeability and low loss characteristics.

Core laminations shall be tightly assembled. The complete core and coil assembly shall be impregnated with non-hydroscopic thermo-setting varnish to provide a high dielectric, moisture resistant, flame retardant seal that is inherently fungus-resistant.

Core and coil assemblies shall be constructed to provide short circuit with stand capability as defined by ANSI and NEMA standards. The complete assembly shall be installed on vibration dampening pads to reduce noise and will be securely bolted to the enclosure base. A flexible grounding conductor shall be installed between the core and coil assembly and the transformer enclosure.

Enclosures shall be ventilated, heavy gauge steel construction finished with light gray paint. Front and rear covers shall be removable to provide access to the terminal compartment. Terminals shall be fully sized to carry the transformer full load current and shall be arranged to accept required UL-Listed cable connectors. Units installed outdoors shall have a UL-Listed type 3R outdoor enclosure, or shall be UL Listed with optional weathershields installed. Standard voltage ratings shall be supplied with NEMA standard taps for the high-voltage windings. Unless specified otherwise, average sound levels (150°C rise) shall meet the NEMA ST20 standards.

Each transformer shall have a securely attached nameplate providing complete electrical ratings, wiring diagram, tap connections, and catalog number, as applicable.

K-Factor Rated for Non-Linear Loads

Siemens offers transformer designs which meet K-Factor ratings. K-Factor is a ratio between the additional losses due to harmonics and the eddy losses at 60Hz. It is used to specify transformers for non-linear loads. Note that K-Factor transformers do not eliminate harmonic distortion; they withstand the non-linear load condition without overheating.

K-Factor Features

- Designed to ANSI and NEMA Standards
- UL K-Factor Listed per UL 1561
- K-Factor Rating Designed to IEEE c57.110
- Aluminum Wound Coils
- Core, Conductors designed for Harmonics and Eddy Currents 150°C
- Rise, 220°C Insulation
- Electrostatic Shield to Attenuate Line Transients
- 200% Neutral Bar (2X Phase current)
- NEMA 3R Enclosure standard for D16 catalog numbers

Transformers shall be designed, manufactured, and tested in accordance with ANSI, NEMA and IEEE Standards and shall be UL Listed. The self-cooled kVA rating shall be suitable for 30°C average, 40°C maximum ambient temperature. Non-Linear rated transformers shall be suitable for nonsinusoidal loads and harmonic distortion as indicated in IEEE C57.110, and shall be designed with the following K-Factor rating (choose one):

- K4 for 50% Non-Linear load
- K13 for 100% Non-Linear load
- K20 for 150% Non-Linear load
- K30 for 200% Non-Linear load

Non-Linear rated transformers shall be UL Listed and shall bear the UL marking on the nameplate along with the specified K-Factor rating. Non-Linear rated transformers shall include the following design features:

- a) Core designed to withstand voltage distortion and high frequency harmonic currents. Magnetic flux density designed to reduce eddy currents and prevent saturation or overheating of the core
- b) Primary and secondary coils designed to minimize stray losses, skin effect losses, and excessive heating from harmonic currents. Coils shall not exceed the specified winding temperature rise, the corresponding hot spot temperature rating, or the 220°C insulation rating while carrying the specified Non-Linear load.
- c) Neutral bus sized for 200% of rated current to withstand circulating currents and triplen harmonics.
- d) An Electrostatic Shield between the primary and secondary winding and grounded to a common point within the transformer enclosure. When properly grounded, the shield shall provide noise isolation and attenuate common mode and transverse mode noise transients under normal loading conditions.
- e) The design and materials used shall enable the transformers to comply with NEMA TP1 efficiency standards.

Options

- Special K-Factor ratings
- Special voltage ratings
- NEMA 3R provided for Series J Single-Phase with Drip Shield (DS)
- 80° or 115°C temperature rise
- Low noise designs
- Copper windings
- Drip Shields (when not provided as standard – see chart on page 8-8)
- Wall mounting brackets (15–75 kVA) (standard in most cases)
- NEMA Premium[®] Efficiencies available only until January 1st, 2016 on 3-Phase but will continue to be available on Single-Phase

^①Temp rise and insulation system values shown are typical. Variation in these values may exist depending on size, design and series, but all will comply with the requirements of UL506 and UL1561.

Distribution Dry Type Transformers

Overview of Transformer Offerings

Selection



Sentron Power Centers

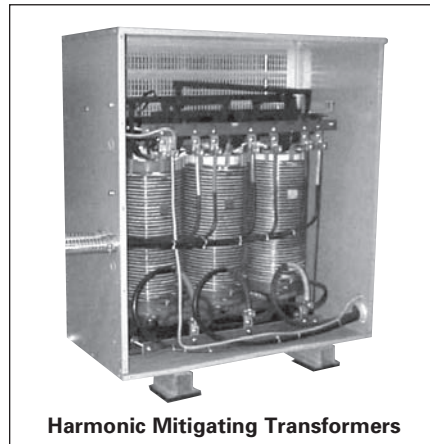

Harmonic Mitigating Transformers



Buck-Boost Transformers

Single Phase Transformers

Siemens offers single phase transformers from 0.25 kVA to 167 kVA with aluminum windings. Common optional modifiers include Low Temperature Rise, Electrostatic Shield, Copper Windings, Wall Mounting Brackets and Drip Shields. See Page 8-10 for common single-phase transformer offerings.

Three Phase Transformers

Siemens offers three phase transformers from 3 kVA through 1000kVA with aluminum windings. Common optional modifiers include K factor, Low Temperature Rise, Electrostatic Shield, Copper Windings, Low Noise, Wall Mounting Brackets, and Drip Shields. All three phase dry-type ventilated transformers will be manufactured to DOE 2016 efficiency standards after January 1, 2016. See page 8-12 for common three-phase transformer offerings.

Motor Drive Isolation Transformers

Siemens Drive Isolation Transformers are designed to meet the rugged demands of AC and DC variable speed drives and to provide circuit isolation from SCR's. The separate primary and secondary windings provide isolation between the incoming line and the load, minimizing line disturbances, feedback and transients caused by SCR firing. Common optional modifiers include low temperature rise, electrostatic shields, copper windings, thermal switches, wall mounting brackets and drip shields. See page 8-15 for more details.

Sentron Power Centers

Siemens Sentron Power Center is a pre-wired combination of a primary breaker disconnect, dry type shielded transformer, secondary breaker disconnect and a secondary power panel all in one convenient package. You save time, space and money by not having to individually assemble, mount and wire these components. Simply add the branch breakers and you're ready to go. Both plug-on and bolt-on breaker panels are available. All Sentron Power Centers are UL-3R listed for indoor and outdoor use. See page 8-17 for more details.

Harmonic Mitigating Transformers

The Sentron Harmonic Mitigating Transformers (HMTs) are designed to meet the needs of modern power distribution systems that contain a large percentage of non-linear equipment that produces harmonics. The Sentron HMTs are specially designed to operate under high non-linear load conditions and have the additional benefit of improving the overall power system reliability. Siemens Sentron Harmonic Mitigating Transformers are only available in three-phase with either one or two secondaries (outputs). See page 8-20 for more details. DOE 2016 efficiency standards apply after January 1, 2016.

Buck-Boost Transformers

The Buck-Boost Transformer has four separate windings; two windings in the primary and two windings in the secondary. It can be used as either an insulating transformer or autotransformer. As an autotransformer, the unit can be corrected to Buck (decrease) or Boost (increase) a supply voltage. Since autotransformers may transmit line disturbances directly, they may be prohibited in some areas by local building codes. As insulating transformers, these units can accommodate a high voltage of 120, 240, or 480 volts. For units with two 12 volt secondaries, two 16 volt secondaries, or two 24 volt secondaries, the output can be wired for either secondary voltage, or for 3-wire secondary. The unit is rated (kVA) as any conventional unit. See Page 8-23 for more details.

Distribution Dry Type Transformers

Catalog Number Coding System for Transformers

Selection

Basic Rating Information (The first five options are dedicated to Basic Rating Information and are the beginning of all Transformer part numbers)

Primary and Secondary terminal lugs are included on certain ventilated transformers. See chart on page 8-8 for lug information

Primary Voltage	Configuration	Suffix
240x120 V	1Ph	A
208 V	1Ph or 3Ph Delta	B
240 V	1Ph or 3Ph Delta	C
480x240 V	1Ph	D
277 V	1Ph	E
480 V	1Ph or 3Ph Delta	F
600 V	1Ph or 3Ph Delta	G
190/200/208/220x380	400/416/440	H
190/208/220/240x380	416/440/480	X

Secondary Voltage ^①	Suffix
240/1Ph 120V ^②	1
240	2
208Y/120	3
480	4
480Y/277	5
380Y/219	6
230Y/133	7
220/1Ph 110V ^②	8
400Y/231	9
416Y/240	0

Taps ^③	Suffix
None	N
2-5% FCBN	R
2-5% (1 FCAN, 1 FCBN)	S
4-2.5% (2 FCAN, 2 FCBN)	T
2-2.5% FCBN	U
4-2.5% FCBN	X
6-2.5% (2 FCAN, 4 FCBN)	Y
4-3.1% (2 FCAN, 2 FCBN)	J
2-3.5% (1 FCAN, 1 FCBN)	K
3-5% (1 FCAN, 2 FCBN)	M

Phase	Suffix
1-Phase	1
3-Phase	3

① 380V Delta secondary is available by special quote.
 ② Includes center tap on one phase often referred to as a lighting tap.

③ Taps are determined by transformer design and are not selectable on standard catalog units.

Optional Modifiers (If applicable, add suffix to part number in this order, from left to right)



Basic Rating Information

kVA	Suffix
0.25	205
0.5	505
0.75	705
1	001
1.5	105
2	002
3	003
5	005
6	006
7.5	007
9	009
10	010
15	015
25	025
30	030
37.5	037
45	045
50	050
75	075
100	100
112.5	112
150	150
167	167
225	225
300	300
500	500
750	750
1000	000

Optional Modifiers (To create a Transformer part number, add applicable suffixes after Basic Rating Information in the order shown here and on next page)

Modifier	Suffix	Description
K-Factor	K4	K-Factor of 1 is standard for all and is not shown as part of part number. Addition of K-Factor options 4-through 30 include Electrostatic Shield (ES) option and 200% neutral
	K13	
	K20	
	K30	
Low Temperature Rise	B	150C temperature rise with 220 insulation class is standard, no suffix code is needed
	F	B=80C (80° C temp rise, can tolerate 30% continuous overload) ^④
	G	F=115C (115° C temp rise, can tolerate 15% continuous overload) ^④
Electrostatic Shield	ES	Electrostatic shield (full width copper foil) for added noise attenuation and reduction of high frequency disturbances.
	ES2	ES is standard with K4-K30 options, so it is not included in catalog number with K4-K30 options. Common mode attenuation is either 50dB (Series J) or 60dB (Series H). Transverse mode attenuation is either 10dB (Series H) or 30dB (Series J). ES2=dual (only applicable to HD1). Series H only.
Copper Wound	C	C=Copper Windings. Aluminum windings are standard, no suffix code needed.
Low Noise	LN3	LN3=3dB below NEMA ST20
	LN5	LN5=5dB below NEMA ST20
	LN()	()=dB below NEMA ST20. Contact sales office for levels other than LN3 & LN5.
Seismic rated	Z4	See chart on page 8-8 for available seismic ratings, not part of catalog number when standard. Not used after DOE 2016 is introduced. Shown for legacy products only.
Totally Enclosed (Non-Ventilated)	TE	TE for Series H is NEMA 4 as a standard. TE for Series J is NEMA 3R as a standard. Other NEMA types available. TE option not available with D16 and TP1.
Totally Enclosed Encapsulated	TEE	Same as TE except encapsulated. TEE not available with D16 and TP1.
Energy Efficient ^⑤	D16	D16=DOE 2016 standards. DOE 2016 standards will replace TP1 For 3 Phase Ventilated Dry Type Transformers for 15 kVA-1000kVA starting Jan. 1, 2016
	TP1	Still valid for single phase and all non ventilated transformers after Jan. 1, 2016
Frequency	LZ	Standard is 60 Hertz. LZ option is 50/60 Hz. Not available with TP1 and D16.

Note 1: If the catalog number will not completely describe the product, it will be identified as SPC-- -kVA-XFMR.

Note 2: "JST" suffix has been removed. Standard units are in stock for immediate shipment in many cases. Contact customer support.

④ With continuous overloads these units will be operating at 150 C rise designs.

⑤ All D16 catalog numbers include NEMA 3R enclosures as standard unless other options chosen change or remove the enclosure.

Distribution Dry Type Transformers

Optional Modifiers (continued)

Modifier	Suffix	Description
Harmonic Mitigation		HD1 for DOE 2016 standard 3 phase dry type ventilated transformers only. Series H only.
	HD1	HD1=1 secondary/single output
"NEMA Premium"	NP	Surpasses NEMA-TP1 (Combine NP with available combined options as shown: "TP1...NP", "HM1...NP", "HM2...NP"). DOE 2016 standards surpass NP. NP not available after January 1, 2016 for DOE 2016 3 phase ventilated dry type transformers (15kVA-1000kVA). NP 1-phase will continue to be available after this date.
		Only to be used with suffix code HD1
Phase Shift for HD1	0	0 degree lagging
	30	30 degree lagging

Optional Product Offerings

1. For non-standard or non-cataloged voltages or non-cataloged primary taps refer to sales office.
2. Non-standard application, 50/60 Hz, special impedance, voltage, etc.-consult sales office.
3. Auto transformers (A)- see page 8-11.
4. Non-standard paint color-contact sales office.
5. Harmonic mitigating transformers-see page 8-15.
6. Transformer and panel combinations-see page 8-13 & 8-14.

Optional Modifiers—continued (If applicable, add suffix to part number in this order, from left to right)



Optional Modifiers (continued)

Modifier	Suffix	Description
Thermal Switches		Typical Thermal Switch is 2.5 A and 250V max, typical installation is one TS per coil with wires brought to a modular screw terminal block on top of the transformer. Customer must specify NO or NC contacts. Contact customer support for special requirements.
	TS7 ()	170C () = no value: 1 switch
	TS8 ()	180C () = 2: 2 switches
	TS0 ()	200C () = 6: 6 switches
TVSS/SPD	TV	Filter Capacitors Secondary Side with Surge Suppression. Available for Series H only. Must specify 100kA or 200kA surge rating.
Terminal Block	TB	Contact customer support for standard terminal block availability. If special terminating requirements please advise
Stainless Steel Enclosure	SS	304 stainless (NEMA 3R if no NEMA type qualifier is specified)
	SS316	316 stainless (NEMA 3R if no NEMA type qualifier is specified)
Enclosure Types	SSN4X	304 stainless is standard. Stainless steel 316 available with a special quote.
		SSN4X Non-Metallic NEMA 4X option not available.®
	N12	NEMA 12 (SSN12 with 304 stainless) 316 available with special quote®
	N4	NEMA 4 (SSN4 with 304 stainless) 316 available with special quote®
Special Impedance		The impedance tolerance per ANSI is +/- 7.5% nominal which is the "I" value shown on Impedance charts. (see SpeedFax Supplement - Addendums H and J) Contact customer support for special requirements (if max or min or min/max range is required.) (If no Min or Max is specified - catalog number will NOT include an "I" value)
	Ix.x or Ix	I2.5 = 2.5% max. or I3 = 3% max. for example. I2.5 to I6.5 are typical values.
	IMx.x	IM2.5 = 2.5% min. or IM3 = 3% min. for example.
Core and Coil Assembly		IMx.xIx.x IM2.5I5.5 = 2.5% min. and 5.5% max. impedance range or IM21I5 = 2% min. and 5% max. range are examples.
	CC	Name plate is displayed on frame bracket. Product may be shipped with or without enclosure.
Wall Mounting Brackets	W®	Some DOE 2016 3 Phase Dry Type Ventilating Transformers include Wall Brackets. See chart on next page for non-DOE availability and DOE 2016 details.
Vent Guard	VG	Vent Guard is a Mesh screen to prevent vent opening access.
Drip Shields (weathershields)	DS®	Most DOE 2016 Dry Type Ventilating Transformers include Drip Shields from 15kVA to 1000kVA. See chart on next page for availability. Also see non-DOE availability.

® The W and DS codes are not always part of the catalog number.
 Only shown as reference when it is not a standard feature of the device.
 ® Not available with D16 or TP1.

Distribution Dry Type Transformers

Catalog Number Coding System for Transformers

Selection

Seismic Rated:

All others not listed below are not seismic rated (contact customer support for Wall Mounting Ratings if needed)

Phase	Encapsulated	Ventilated		Non Ventilated
	Series J ^②	Series J ^②	Series H ^③	Series J ^②
1	1-25kVA (Wall Mounted) S _{DS} =2.00g ; z/h = 1.00 ; I _p = 1.5	1-250 kVA (Floor Mounted) S _{DS} =2.00g ; z/h = 1.00 ; I _p = 1.5	15-167kVA (Floor Mounted Only) S _{DS} =2.00g ; z/h = 1.00 ; I _p = 1.5	1-250kVA (Floor Mounted Only) S _{DS} =2.00g ; z/h = 1.00 ; I _p = 1.5
3	3-75kVA (Floor Mounted) S _{DS} =2.00g ; z/h = 1.00 ; I _p = 1.5	1-1000kVA (Floor Mounted) S _{DS} =2.00g ; z/h = 1.00 ; I _p = 1.5	15-750kVA (Floor Mounted Only) ^① S _{DS} =2.00g ; z/h = 1.00 ; I _p = 1.5	1-500kVA (Floor Mounted Only) S _{DS} =2.00g ; z/h = 1.00 ; I _p = 1.5
DOE 2016 3 Phase Ventilated				
3	NA	1-1000kVA (Floor Mounted)	15-750kVA (Floor Mounted Only)	NA

① Seismic labels are standard up to 750kVA with 150C temperature rise.

② Series J Results are filed with OSHPD per OSP-0109-10.

③ Series H results are filed with OSHPD per OSP-0136-10.

Seismic Qualified according to:

- International Building Code (IBC) 2012
- American Society of Civil Engineers (ASCE) 7-10

Wall Mounting Brackets and Drip Shields

1 Phase Dry Type Wall Brackets/Drip Shields				
kVA	Wall Mounting Brackets (W)		Drip Shields (DS)	
	Series J	Series H	Series J	Series H
0.25-25 Encapsulated	Wall Mount only	NA	NA	NA
All items below are Ventilated				
15, 25	Optional**	Standard	Standard	Standard
37.5	Optional**	See Note 1	Standard	Standard
50	Optional**	See Note 1	Standard	Standard
75	NA	See Note 1	Standard	Standard
100-500	NA		Standard	Standard
3 Phase Dry Type Ventilated DOE 2016 Wall Brackets/Drip Shields				
kVA	Wall Mounting Brackets (W)		Drip Shields (DS)	
	Series J	Series H	Series J	Series H
15, 30	Optional**	Standard	Standard	Standard
45	Optional**	See Note 1	Standard	Standard
75	See Note 2	See Note 1	Standard	Standard
112.5-1000	N/A	See Note 1	Standard	Standard
3 Phase Dry Type Encapsulated				
kVA	Wall Mounting Brackets (W)		Drip Shields (DS)	
	Series J	Series H	Series J	Series H
3-15	Standard	Standard	N/A	N/A

1. Standard with DH1 and DH2 enclosures. For DH3 enclosure, Series H transformers 1000 lbs or less can be wall mounted with kit p/n TWB75H. The DH3 designation is found on the lower left corner of the Front View Outline on the transformer drawing.
2. Optional except with copper windings or options B, K13, K20. See table page 8-27.

**For DOE 2016 and 1-Phase ventilated, cost of transformer will not include wall brackets. Wall brackets will be an additional charge.

Standard Terminal Lug Offerings^{①②}

(Primary and Secondary) for Ventilated Transformers (150 Degree Rise - Series J only - Without a K rating)

1-Phase					3-Phase				
kVA	120/240V	208V	480V	600V	kVA	120/240V	208V	480V	600V
0-15	Contact customer support				0-15	Contact customer support			
15	#2/0-6	#14-2	#14-2	#14-2	15	#14-2	#14-2	#14-2	#14-2
25	250MCM-6	250MCM-6	#14-2	#14-2	30	#2/0-6	#2/0-6	#14-2	#14-2
37.5	350MCM-6	350MCM-6	#14-2	#14-2	45	250MCM-6	250MCM-6	#14-2	#14-2
50	600MCM-2	600MCM-2	#2/0-6	#2/0-6	75	600MCM-2	350MCM-6	#2/0-6	#2/0-6
>50	Contact customer support				>75	Contact customer support			

① Values listed above are for standard configurations.

There may be slight variations depending on requirements. Contact Customer Support for special requirements

② For Series H, see chart in Series H Addendum - Page H-16. Lug sizes are not available except on cutsheets. Contact Customer Support for special requirements.

Distribution Dry Type Transformers

Single Phase

Selection

kVA	Catalog Number	Taps ^①	Temperature Rise	Insulation	Mounting Type ^{②③④}	Drip Shield Provided ^③	Enclosure Style – Type ^④	Optional Modifications
208 Volts Primary, 120/240 Volts Secondary								
1	1B1N001	N	95° C	130° C	Wall	No	Encapsulated – NEMA 3R	1, 2, 4
2	1B1N002	N	135° C	180° C	Wall	No		1, 2, 4
3	1B1N003	N	135° C	180° C	Wall	No		1, 2, 4
5	1B1N005	N	135° C	180° C	Wall	No		1, 2, 4
7.5	1B1N007	N	135° C	180° C	Wall	No		1, 2, 4
10	1B1N010	N	135° C	180° C	Wall	No		1, 2, 4
15	1B1N015	N	135° C	180° C	Wall	No	1, 2, 4	
15	1B1Y015TP1	Y	150° C	220° C	Floor & Wall	Yes	Ventilated – NEMA 3R	1, 2, 3
25	1B1Y025TP1	Y	150° C	220° C	Floor & Wall	Yes		1, 2, 3
37.5	1B1Y037TP1	Y	150° C	220° C	Floor & Wall	Yes		1, 2, 3
50	1B1S050TP1	Y ^⑤ S ^⑥	150° C	220° C	Floor & Wall	Yes		1, 2, 3
75	1B1S075TP1	Y ^⑤ S ^⑥	150° C	220° C	Floor	Yes	Ventilated – NEMA 3R	1, 2, 3
100	1B1S100TP1	Y ^⑤ S ^⑥	150° C	220° C	Floor	Yes		1, 2, 3
167	1B1S167TP1	Y ^⑤ S ^⑥	150° C	220° C	Floor	Yes		1, 2, 3

240 × 480 Volts Primary, 120/240 Volts Secondary								
.25	1D1N205	N	95° C	130° C	Wall	No	Encapsulated – NEMA 3R	1, 2, 4
.50	1D1N505	N	95° C	130° C	Wall	No		1, 2, 4
.75	1D1N705	N	95° C	130° C	Wall	No		1, 2, 4
1.0	1D1N001	N	95° C	130° C	Wall	No		1, 2, 4
1.5	1D1N105	N	135° C	180° C	Wall	No	Encapsulated – NEMA 3R	1, 2, 4
2.0	1D1N002	N	135° C	180° C	Wall	No		1, 2, 4
3.0	1D1N003	N	135° C	180° C	Wall	No		1, 2, 4
5.0	1D1N005	N	135° C	180° C	Wall	No		1, 2, 4
7.5	1D1N007	N	135° C	180° C	Wall	No		1, 2, 4
10.0	1D1N010	N	135° C	180° C	Wall	No		1, 2, 4
15	1D1N015	N	135° C	180° C	Wall	No	1, 2, 4	
15	1D1Y015TP1	Y	150° C	220° C	Floor & Wall	Yes	Ventilated – NEMA 3R	1, 2, 3
25	1D1Y025TP1	Y	150° C	220° C	Floor & Wall	Yes		1, 2, 3
37.5	1D1Y037TP1	Y	150° C	220° C	Floor & Wall	Yes		1, 2, 3
50	1D1Y050TP1	Y	150° C	220° C	Floor & Wall	Yes		1, 2, 3
75	1D1Y075TP1	Y	150° C	220° C	Floor & Wall	Yes	Ventilated – NEMA 3R	1, 2, 3
100	1D1Y100TP1	Y	150° C	220° C	Floor	Yes		1, 2, 3
167	1D1Y167TP1	Y	150° C	220° C	Floor	Yes		1, 2, 3

277 Volts Primary, 120/240 Volts Secondary								
3	1E1U003	U	135° C	180° C	Wall	No	Encapsulated – NEMA 3R	1, 2, 4
5	1E1U005	U	135° C	180° C	Wall	No		1, 2, 4
7.5	1E1U007	U	135° C	180° C	Wall	No		1, 2, 4
10	1E1U010	U	135° C	180° C	Wall	No		1, 2, 4
15	1E1U015	U	135° C	180° C	Wall	No		1, 2, 4
25	1E1U025	U	135° C	180° C	Wall	No		1, 2, 4

480 Volts Primary, 120/240 Volts Secondary								
3	1F1R003	R	135° C	180° C	Wall	No	Encapsulated – NEMA 3R	1, 2, 4
5	1F1R005	R	135° C	180° C	Wall	No		1, 2, 4
7.5	1F1R007	R	135° C	180° C	Wall	No		1, 2, 4
10	1F1R010	R	135° C	180° C	Wall	No		1, 2, 4
15	1F1R015	R	135° C	180° C	Wall	No		1, 2, 4
25	1F1R025	R	135° C	180° C	Wall	No		1, 2, 4

Optional Modifications Table (Contact Sales office for List Price)

Optional (commonly used) Modifications	Catalog Suffix Code
1a. 115° C Rise	F
1b. 80° C Rise	B
2. Electrostatic Shield	ES
3. Copper Windings	C
4. Wall Mounting Brackets	W
5. Drip Shields	DS

Taps

Description	Designation
None	N
2–5% FCBN	R
2–5% (1 FCAN, 1 FCBN)	S
2–2.5% FCBN	U
6–2.5% (2 FCAN, 4 FCBN)	Y

① Actual taps may vary based on volts/turn ratio.
 ② Wall designations for units having standard features.
 ③ For outdoor application. Ventilated transformers requiring drip shields/weathershields are UL listed for outdoor use. All are NEMA 3R rated.

④ Encapsulated transformers are UL listed for indoor/outdoor use. NEMA 3R rated.
 ⑤ Items marked floor and wall can be wall mounted with optional wall bracket.

⑥ See table on page 8-8 for available kits.
 ⑦ Series H Tap Standard.
 ⑧ Series J Tap Standard.

Distribution Dry Type Transformers

Single Phase

Selection

kVA	Catalog Number	Taps ^①	Temperature Rise	Insulation	Mounting Type ^{②③④}	Drip Shield Provided ^⑤	Enclosure Style ^⑥	Optional Modifications
600 Volts Primary, 120/240 Volts Secondary								
3	1G1R003	R	135° C	180° C	Wall	No	Encapsulated – NEMA 3R	1, 2, 4
5	1G1R005	R	135° C	180° C	Wall	No		1, 2, 4
7.5	1G1R007	R	135° C	180° C	Wall	No		1, 2, 4
10	1G1R010	R	135° C	180° C	Wall	No		1, 2, 4
15	1G1R015	R	135° C	180° C	Wall	No		1, 2, 4
25	1G1R025	R	135° C	180° C	Wall	No		1, 2, 4
25	1G1T025TP1	Y ^⑦ T ^⑧	150° C	220° C	Floor & Wall	Yes	Ventilated – NEMA 3R	1, 2, 3
37.5	1G1T037TP1	Y ^⑦ T ^⑧	150° C	220° C	Floor & Wall	Yes		1, 2, 3
50	1G1T050TP1	Y ^⑦ T ^⑧	150° C	220° C	Floor & Wall	Yes		1, 2, 3
75	1G1T075TP1	Y ^⑦ T ^⑧	150° C	220° C	Floor	Yes	Ventilated – NEMA 3R	1, 2, 3
100	1G1T100TP1	Y ^⑦ T ^⑧	150° C	220° C	Floor	Yes		1, 2, 3
167	1G1T167TP1	Y ^⑦ T ^⑧	150° C	220° C	Floor	Yes		1, 2, 3

Overseas Model 190/200/208/220 x 380/400/416/440 Volts Primary, 120/240 Volts Secondary—1Ø, 50/60 Hz

1	1H1N001	N	95° C	130° C	Wall	No	Encapsulated – NEMA 3R	2, 3
2	1H1N002 ^⑨	N	135° C	180° C	Wall	No		2, 3
3	1H1N003 ^⑨	N	135° C	180° C	Wall	No		2, 3
5	1H1N005 ^⑨	N	135° C	180° C	Wall	No		2, 3
7.5	1H1N007	N	135° C	180° C	Wall	No		2, 3
10	1H1N010	N	135° C	180° C	Wall	No		2, 3
15	1H1N015	N	135° C	180° C	Wall	No		2, 3
25	1H1N025	N	135° C	180° C	Wall	No		2, 3

Overseas Model 190/208/220/240 x 380/416/440/480 Volts Primary, 120/240 Volts Secondary—1Ø, 50/60 Hz

1	1X1N001	N	95° C	130° C	Wall	No	Encapsulated – NEMA 3R	2, 3
2	1X1N002 ^⑨	N	135° C	180° C	Wall	No		2, 3
3	1X1N003 ^⑨	N	135° C	180° C	Wall	No		2, 3
5	1X1N005 ^⑨	N	135° C	180° C	Wall	No		2, 3
7.5	1X1N007	N	135° C	180° C	Wall	No		2, 3
10	1X1N010	N	135° C	180° C	Wall	No		2, 3
15	1X1N015	N	135° C	180° C	Wall	No		2, 3
25	1X1N025	N	135° C	180° C	Wall	No		2, 3

Overseas Model 190/200/208/220 x 380/400/416/440 Volts Primary, 110/220 Volts Secondary—1Ø, 50/60 Hz

1	1H8N001	N	95° C	130° C	Wall	No	Encapsulated – NEMA 3R	2, 3
2	1H8N002 ^⑨	N	135° C	180° C	Wall	No		2, 3
3	1H8N003 ^⑨	N	135° C	180° C	Wall	No		2, 3
5	1H8N005 ^⑨	N	135° C	180° C	Wall	No		2, 3
7.5	1H8N007	N	135° C	180° C	Wall	No		2, 3

Optional Modifications Table (Contact Sales office for List Price)

Optional (commonly used) Modifications	Catalog Suffix Code
1a. 115° C Rise	F
1b. 80° C Rise	B
2. Electrostatic Shield	ES
3. Copper Windings	C
4. Wall Mounting Brackets	W
5. Drip Shields	DS

Taps

Description	Designation
None	N
2–5% FCBN	R
2–5% (1 FCAN, 1 FCBN)	S
2–2.5% FCBN	U
6–2.5% (2 FCAN, 4 FCBN)	Y

① Actual taps may vary based on volts/turn ratio.
 ② Wall designations for units having standard features.
 ③ For outdoor application. Ventilated transformers requiring drip shields/weathershields are UL listed for outdoor use. All are NEMA 3R rated.

④ Encapsulated transformers are UL listed for indoor/outdoor use. NEMA 3R rated.
 ⑤ Items marked floor and wall can be wall mounted with optional wall bracket.

⑥ See table on page 8-8 for available kits.
 ⑦ Series H Tap Standard.
 ⑧ Series J Tap Standard.
 ⑨ Available with CE mark.

Distribution Dry Type Transformers

Three Phase

Selection

kVA	Catalog Number	Taps ^①	Temperature Rise	Insulation	Mounting Type ^{②③④}	Drip Shield Provided ^⑤	Enclosure Style ^⑥	Optional Modifications
480 Volts Δ Primary, 240 Volts Δ Secondary With 120 Volt Tap On B Phase^⑤								
15	3F1Y015D16	Y	150° C	220° C	Floor & Wall	Yes	Ventilated – NEMA 3R	1, 2, 3, 4
30	3F1Y030D16	Y	150° C	220° C	Floor & Wall	Yes		1, 2, 3, 4
45	3F1Y045D16	Y	150° C	220° C	Floor & Wall	Yes		1, 2, 3, 4
75	3F1Y075D16	Y	150° C	220° C	Floor	Yes	Ventilated – NEMA 3R	1, 2, 3, 4
112.5	3F1Y112D16	Y	150° C	220° C	Floor	Yes		1, 2, 3, 4
150	3F1Y150D16	Y	150° C	220° C	Floor	Yes		1, 2, 3
225	3F1Y225D16	Y	150° C	220° C	Floor	Yes		1, 2, 3
300	3F1Y300D16	Y	150° C	220° C	Floor	Yes		1, 2, 3
500	3F1T500D16	Y [Ⓢ] , T [Ⓢ]	150° C	220° C	Floor	Yes		1, 2, 3
750	3F1T750D16	Y [Ⓢ] , T [Ⓢ]	150° C	220° C	Floor	Yes		1, 2, 3

480 Volts Δ Primary, 240 Volts Δ Secondary								
3	3F2R003 [Ⓢ]	R	135° C	180° C	Wall	No	Encapsulated – NEMA 3R	1, 2, 3
6	3F2R006 [Ⓢ]	R	135° C	180° C	Wall	No		1, 2, 3
9	3F2R009 [Ⓢ]	R	135° C	180° C	Wall	No		1, 2, 3
15	3F2R015 [Ⓢ]	R	135° C	180° C	Wall	No		1, 2, 3

480 Volts Δ Primary, 208Y/120 Volts Secondary								
3	3F3R003	R	135° C	180° C	Wall	No	Encapsulated – NEMA 3R	1, 2, 3
6	3F3R006	R	135° C	180° C	Wall	No		1, 2, 3
9	3F3R009	R	135° C	180° C	Wall	No		1, 2, 3
15	3F3R015	R	135° C	180° C	Wall	No		1, 2, 3
15	3F3Y015D16	Y	150° C	220° C	Floor & Wall	Yes	Ventilated – NEMA 3R	1, 2, 3, 4, 6
30	3F3Y030D16	Y	150° C	220° C	Floor & Wall	Yes		1, 2, 3, 4, 6
45	3F3Y045D16	Y	150° C	220° C	Floor & Wall	Yes		1, 2, 3, 4, 6
75	3F3Y075D16	Y	150° C	220° C	Floor & Wall	Yes	Ventilated – NEMA 3R	1, 2, 3, 4, 6
112.5	3F3Y112D16	Y	150° C	220° C	Floor	Yes		1, 2, 3, 6
150	3F3Y150D16	Y	150° C	220° C	Floor	Yes		1, 2, 3, 6
225	3F3Y225D16	Y	150° C	220° C	Floor	Yes		1, 2, 3, 6
300	3F3Y300D16	Y	150° C	220° C	Floor	Yes		1, 2, 3, 6
500	3F3T500D16	Y [Ⓢ] , T [Ⓢ]	150° C	220° C	Floor	Yes		1, 2, 3, 6
750	3F3T750D16	Y [Ⓢ] , T [Ⓢ]	150° C	220° C	Floor	Yes		1, 2, 3, 6
1000	3F3T000D16	T	150° C	220° C	Floor	Yes		1, 2, 3, 6

kVA	Catalog Number	Taps ^①	Temperature Rise	Insulation	Mounting Type	Drip Shield Required	Optional Modifications	Avg. Sound Level
Totally Enclosed Transformers, Indoor/Outdoor Use 480 Volts Δ Primary, 208Y/120 Volts Secondary^⑦								
15	3F3Y015TE	Y	150° C	220° C	Floor	No	1, 2, 3	50dB
30	3F3Y030TE	Y	150° C	220° C	Floor	No	1, 2, 3	50dB
45	3F3Y045TE	Y	150° C	220° C	Floor	No	1, 2, 3	50dB
75	3F3Y075TE	Y	150° C	220° C	Floor	No	1, 2, 3	55dB
112.5	3F3Y112TE	Y	150° C	220° C	Floor	No	1, 2, 3	55dB
150	3F3Y150TE	Y	150° C	220° C	Floor	No	1, 2, 3	55dB
225	3F3Y225TE	Y	150° C	220° C	Floor	No	1, 2, 3	57dB
300	3F3Y300TE	Y	150° C	220° C	Floor	No	1a, 2, 3	57dB

480 Volts Δ Primary, 240 Volts Δ Secondary with 120V Lighting Tap on B Phase^⑦								
15	3F1Y015TE	Y	150° C	220° C	Floor	No	1, 2, 3	50dB
30	3F1Y030TE	Y	150° C	220° C	Floor	No	1, 2, 3	50dB
45	3F1Y045TE	Y	150° C	220° C	Floor	No	1, 2, 3	50dB
75	3F1Y075TE	Y	150° C	220° C	Floor	No	1, 2, 3	55dB
112.5	3F1Y112TE	Y	150° C	220° C	Floor	No	1, 2, 3	55dB
150	3F1Y150TE	Y	150° C	220° C	Floor	No	1, 2, 3	55dB
225	3F1Y225TE	Y	150° C	220° C	Floor	No	1, 2, 3	57dB
300	3F1Y300TE	Y	150° C	220° C	Floor	No	1a, 2, 3	57dB

Optional Modifications Table (Contact Sales office for List Price)

Optional (commonly used) Modifications	Catalog Suffix Code
1a. 115° C Rise	F
1b. 80° C Rise	B
2. Electrostatic Shield	ES
3. Copper Windings	C
4. Wall Mounting Brackets	W
6. Low noise—XdB below std.	LNx

Taps

Description	Designation
None	N
2-5% FCBN	R
2-5% (1 FCAN, 1 FCBN)	S
2-2.5% FCBN	U
6-2.5% (2 FCAN, 4 FCBN)	Y

① Actual taps may vary based on volts/turn ratio.
 ② Wall designations for units having standard features.
 ③ Ventilated transformers with drip shields are UL listed for outdoor use. NEMA 3R rated.
 ④ Encapsulated transformers are UL listed for indoor/outdoor use. NEMA 3R rated.

⑤ See table on page 8-8 for available kits.
 ⑥ 240 volt secondary (3F2) is available in 3-phase 3 to 15kVA only.
 ⑦ TE units will have inrush equal to 2 sizes larger than rated kVA.

⑧ Items marked floor and wall can be wall mounted with optional wall bracket that may be identified with "W" suffix on catalog number.
 ⑨ Wall mounting for 150° C temperature rise.
 ⑩ Series H Tap Standard.
 ⑪ Series J Tap Standard.

Distribution Dry Type Transformers

Three Phase

Selection

kVA	Catalog Number	Taps ^①	Temperature Rise	Insulation	Mounting Type ^{②⑥⑦}	Drip Shield Provided ^③	Enclosed Type ^④	Optional Modifications
480 Volts Δ Primary, 480Y/277 Volts Secondary								
15	3F5R015	R	135° C	180° C	Wall	No	Encapsulated – NEMA 3R	1, 2, 3
15	3F5Y015D16	Y	150° C	220° C	Floor & Wall	Yes	Ventilated – NEMA 3R	1, 2, 3, 4, 6
30	3F5Y030D16	Y	150° C	220° C	Floor & Wall	Yes	Ventilated	1, 2, 3, 4, 6
45	3F5Y045D16	Y	150° C	220° C	Floor & Wall	Yes	Ventilated	1, 2, 3, 4, 6
75	3F5Y075D16	Y	150° C	220° C	Floor	Yes	Ventilated – NEMA 3R	1, 2, 3, 6
112.5	3F5Y112D16	Y	150° C	220° C	Floor	Yes	Ventilated	1, 2, 3, 6
150	3F5Y150D16	Y	150° C	220° C	Floor	Yes	Ventilated	1, 2, 3, 6
225	3F5Y225D16	Y	150° C	220° C	Floor	Yes	Ventilated	1, 2, 3, 6
300	3F5Y300D16	Y	150° C	220° C	Floor	Yes	Ventilated	1, 2, 3, 6
500	3F5T500D16	Y ^⑧ , T ^⑨	150° C	220° C	Floor	Yes	Ventilated	1, 2, 3, 6

3-Phase 480 Δ — 208Y/120 K-4 (50% Non-Linear Load)^⑤

15	3F3Y015K4D16	Y	150° C	220° C	Floor & Wall	Yes	Ventilated – NEMA 3R	1, 3, 4, 6
30	3F3Y030K4D16	Y	150° C	220° C	Floor & Wall	Yes	Ventilated	1, 3, 4, 6
45	3F3Y045K4D16	Y	150° C	220° C	Floor & Wall	Yes	Ventilated	1, 3, 4, 6
75	3F3Y075K4D16	Y	150° C	220° C	Floor	Yes	Ventilated – NEMA 3R	1, 3, 6
112.5	3F3Y112K4D16	Y	150° C	220° C	Floor	Yes	Ventilated	1, 3, 6
150	3F3Y150K4D16	Y	150° C	220° C	Floor	Yes	Ventilated	1, 3, 6
225	3F3Y225K4D16	Y	150° C	220° C	Floor	Yes	Ventilated	1, 3, 6
300	3F3Y300K4D16	Y	150° C	220° C	Floor	Yes	Ventilated	1, 3, 6
500	3F3T500K4D16	Y ^⑧ , T ^⑨	150° C	220° C	Floor	Yes	Ventilated	1, 3, 6

3-Phase 480 Δ — 208Y/120 K-13 (100% Non-Linear Load)^⑤

15	3F3Y015K13D16	Y	150° C	220° C	Floor & Wall	Yes	Ventilated – NEMA 3R	1, 3, 4, 6
30	3F3Y030K13D16	Y	150° C	220° C	Floor & Wall	Yes	Ventilated	1, 3, 4, 6
45	3F3Y045K13D16	Y	150° C	220° C	Floor & Wall	Yes	Ventilated	1, 3, 4, 6
75	3F3Y075K13D16	Y	150° C	220° C	Floor	Yes	Ventilated – NEMA 3R	1, 3, 6
112.5	3F3Y112K13D16	Y	150° C	220° C	Floor	Yes	Ventilated	1, 3, 6
150	3F3Y150K13D16	Y	150° C	220° C	Floor	Yes	Ventilated	1, 3, 6
225	3F3Y225K13D16	Y	150° C	220° C	Floor	Yes	Ventilated	1, 3, 6
300	3F3Y300K13D16	Y	150° C	220° C	Floor	Yes	Ventilated	1, 3, 6
500	3F3T500K13D16	Y ^⑧ , T ^⑨	150° C	220° C	Floor	Yes	Ventilated	1, 3, 6

3-Phase 480 Δ — 208Y/120 K-20 (125% Non-Linear Load)^⑤

15	3F3Y015K20D16	Y	150° C	220° C	Floor & Wall	Yes	Ventilated – NEMA 3R	1, 3, 4, 6
30	3F3Y030K20D16	Y	150° C	220° C	Floor & Wall	Yes	Ventilated	1, 3, 4, 6
45	3F3Y045K20D16	Y	150° C	220° C	Floor & Wall	Yes	Ventilated	1, 3, 4, 6
75	3F3Y075K20D16	Y	150° C	220° C	Floor	Yes	Ventilated – NEMA 3R	1, 3, 6
112.5	3F3Y112K20D16	Y	150° C	220° C	Floor	Yes	Ventilated	1, 3, 6
150	3F3Y150K20D16	Y	150° C	220° C	Floor	Yes	Ventilated	1, 3, 6
225	3F3Y225K20D16	Y	150° C	220° C	Floor	Yes	Ventilated	1, 3, 6
300	3F3Y300K20D16	Y	150° C	220° C	Floor	Yes	Ventilated	1, 3, 6
500	3F3T500K20D16	Y ^⑧ , T ^⑨	150° C	220° C	Floor	Yes	Ventilated	1, 3, 6

3-Phase 480 Δ — 208Y/120 K-30 (150% Non-Linear Load)^⑤

15	3F3Y015K30D16	Y	150° C	220° C	Floor & Wall	Yes	Ventilated – NEMA 3R	1, 3, 4, 6
30	3F3Y030K30D16	Y	150° C	220° C	Floor & Wall	Yes	Ventilated	1, 3, 4, 6
45	3F3Y045K30D16	Y	150° C	220° C	Floor & Wall	Yes	Ventilated	1, 3, 4, 6
75	3F3Y075K30D16	Y	150° C	220° C	Floor	Yes	Ventilated – NEMA 3R	1, 3, 6
112.5	3F3Y112K30D16	Y	150° C	220° C	Floor	Yes	Ventilated	1, 3, 6
150	3F3Y150K30D16	Y	150° C	220° C	Floor	Yes	Ventilated	1, 3, 6
225	3F3Y225K30D16	Y	150° C	220° C	Floor	Yes	Ventilated	1, 3, 6
300	3F3Y300K30D16	Y	150° C	220° C	Floor	Yes	Ventilated	1, 3, 6
500	3F3T500K30D16	Y ^⑧ , T ^⑨	150° C	220° C	Floor	Yes	Ventilated	1, 3, 6

Optional Modifications Table (Contact Sales office for List Price)

Optional (commonly used) Modifications	Catalog Suffix Code
1a. 115° C Rise	F
1b. 80° C Rise	B
2. Electrostatic Shield	ES
3. Copper Windings	C
4. Wall Mounting Brackets	W
6. Low noise — XdB below std.	LNx

Taps

Description	Designation
None	N
2–5% FCBN	R
2–5% (1 FCAN, 1 FCBN)	S
2–2.5% FCBN	U
6–2.5% (2 FCAN, 4 FCBN)	Y

① Actual taps may vary based on volts/turn ratio.

② Wall designations for units having standard features.

③ Ventilated transformers drip shields are UL listed for outdoor use.

④ Encapsulated transformers are UL listed for indoor/outdoor use. 15kVA with R taps also available in ventilated enclosure.

⑤ K-Factor transformers equipped with electrostatic shield and 200% neutral as standard features.

⑥ See table on page 8-8 for available kits.

⑦ Items marked floor and wall can be wall mounted with optional wall bracket that may be identified with

“W” suffix on catalog number. Wall mounting brackets will not be available for Series J 75kVA with copper winding options.

⑧ Series H Tap Standard.

⑨ Series J Tap Standard.

Distribution Dry Type Transformers

Three Phase

Selection

kVA	Catalog Number	Taps ^①	Temperature Rise	Insulation	Mounting Type ^{②③④}	Drip Shield Provided ^③	Enclosure Style – Type ^④	Optional Modifications
208 Volts Δ Primary, 208Y/120 Volts Secondary								
3	3B3R003	R	135° C	180° C	Wall	No	Encapsulated – NEMA 3R	1, 2, 3
6	3B3R006	R	135° C	180° C	Wall	No		1, 2, 3
9	3B3R009	R	135° C	180° C	Wall	No		1, 2, 3
15	3B3R015	R	135° C	180° C	Wall	No		1, 2, 3
15	3B3Y015D16	Y	150° C	220° C	Floor & Wall	Yes	Ventilated – NEMA 3R	1, 2, 3, 4, 6
30	3B3Y030D16	Y	150° C	220° C	Floor & Wall	Yes		1, 2, 3, 4, 6
45	3B3Y045D16	Y	150° C	220° C	Floor & Wall	Yes		1, 2, 3, 4, 6
75	3B3Y075D16	Y	150° C	220° C	Floor	Yes	Ventilated – NEMA 3R	1, 2, 3, 6
112.5	3B3Y112D16	Y	150° C	220° C	Floor	Yes		1, 2, 3, 6
150	3B3M150D16	Y [⊙] , M [⊙]	150° C	220° C	Floor	Yes		1, 2, 3, 6
225	3B3M225D16	S [⊙] , M [⊙]	150° C	220° C	Floor	Yes	Ventilated – NEMA 3R	1, 2, 3, 6
300	3B3M300D16	S [⊙] , M [⊙]	150° C	220° C	Floor	Yes		1, 2, 3, 6
500	3B3M500D16	S [⊙] , M [⊙]	150° C	220° C	Floor	Yes		1, 2, 3, 6

208 Volt Δ Primary, 240 Δ Secondary with 120 Volt TAP on B Phase^②								
15	3B1Y015D16	Y	150° C	220° C	Floor & Wall	Yes	Ventilated – NEMA 3R	1, 2, 3, 4, 6
30	3B1Y030D16	Y	150° C	220° C	Floor & Wall	Yes		1, 2, 3, 4, 6
45	3B1Y045D16	Y	150° C	220° C	Floor & Wall	Yes		1, 2, 3, 4, 6
75	3B1Y075D16	Y	150° C	220° C	Floor	Yes	Ventilated – NEMA 3R	1, 2, 3, 6
112.5	3B1Y112D16	Y	150° C	220° C	Floor	Yes		1, 2, 3, 6
150	3B1M150D16	Y [⊙] , M [⊙]	150° C	220° C	Floor	Yes		1, 2, 3, 6
225	3B1M225D16	Y [⊙] , M [⊙]	150° C	220° C	Floor	Yes		1, 2, 3, 6

208 Volts Δ Primary, 480Y/277 Volts Secondary								
9	3B5R009	R	135° C	180° C	Wall	No	Encapsulated – NEMA 3R	1, 2, 3
15	3B5R015	R	135° C	180° C	Wall	No		1, 2, 3
15	3B5Y015D16	Y	150° C	220° C	Floor & Wall	Yes	Ventilated – NEMA 3R	1, 2, 3, 4, 6
30	3B5Y030D16	Y	150° C	220° C	Floor & Wall	Yes		1, 2, 3, 4, 6
45	3B5Y045D16	Y	150° C	220° C	Floor & Wall	Yes		1, 2, 3, 4, 6
75	3B5Y075D16	Y	150° C	220° C	Floor	Yes	Ventilated – NEMA 3R	1, 2, 3, 6
112.5	3B5Y112D16	Y	150° C	220° C	Floor	Yes		1, 2, 3, 6
150	3B5M150D16	Y [⊙] , M [⊙]	150° C	220° C	Floor	Yes		1, 2, 3, 6
225	3B5M225D16	S [⊙] , M [⊙]	150° C	220° C	Floor	Yes	Ventilated – NEMA 3R	1, 2, 3, 6
300	3B5M300D16	S [⊙] , M [⊙]	150° C	220° C	Floor	Yes		1, 2, 3, 6
500	3B5M500D16	S [⊙] , M [⊙]	150° C	220° C	Floor	Yes		1, 2, 3, 6

240 Volts Δ Primary, 208Y/120 Volts Secondary								
15	3C3Y015D16	Y	150° C	220° C	Floor & Wall	Yes	Ventilated – NEMA 3R	1, 2, 3, 4, 6
30	3C3Y030D16	Y	150° C	220° C	Floor & Wall	Yes		1, 2, 3, 4, 6
45	3C3Y045D16	Y	150° C	220° C	Floor & Wall	Yes		1, 2, 3, 4, 6
75	3C3Y075D16	Y	150° C	220° C	Floor	Yes	Ventilated – NEMA 3R	1, 2, 3, 6
112.5	3C3Y112D16	Y	150° C	220° C	Floor	Yes		1, 2, 3, 6
150	3C3Y150D16	Y	150° C	220° C	Floor	Yes		1, 2, 3, 6
225	3C3M225D16	S [⊙] , M [⊙]	150° C	220° C	Floor	Yes	Ventilated – NEMA 3R	1, 2, 3, 6
300	3C3M300D16	S [⊙] , M [⊙]	150° C	220° C	Floor	Yes		1, 2, 3, 6
500	3C3M500D16	S [⊙] , M [⊙]	150° C	220° C	Floor	Yes		1, 2, 3, 6

240 Volts Δ Primary, 480Y/277 Volts Secondary								
15	3C5Y015D16	Y	150° C	220° C	Floor & Wall	Yes	Ventilated – NEMA 3R	1, 2, 3, 4, 6
30	3C5Y030D16	Y	150° C	220° C	Floor & Wall	Yes		1, 2, 3, 4, 6
45	3C5Y045D16	Y	150° C	220° C	Floor & Wall	Yes		1, 2, 3, 4, 6
75	3C5Y075D16	Y	150° C	220° C	Floor	Yes	Ventilated – NEMA 3R	1, 2, 3, 6
112.5	3C5Y112D16	Y	150° C	220° C	Floor	Yes		1, 2, 3, 6
150	3C5Y150D16	Y	150° C	220° C	Floor	Yes		1, 2, 3, 6
225	3C5M225D16	S [⊙] , M [⊙]	150° C	220° C	Floor	Yes	Ventilated – NEMA 3R	1, 2, 3, 6
300	3C5M300D16	S [⊙] , M [⊙]	150° C	220° C	Floor	Yes		1, 2, 3, 6
500	3C5M500D16	S [⊙] , M [⊙]	150° C	220° C	Floor	Yes		1, 2, 3, 6

Optional Modifications Table

Optional (commonly used) Modifications	Catalog Suffix Code
1a. 115° C Rise	F
1b. 80° C Rise	B
2. Electrostatic Shield	ES
3. Copper Windings	C
4. Wall Mounting Brackets1	W
6. Low noise—XdB below std.	LNX

Taps

Description	Designation
None	N
2–5% FCBN	R
2–5% (1 FCAN, 1 FCBN)	S
2–2.5% FCBN	U
6–2.5% (2 FCAN, 4 FCBN)	Y

Seismic Ratings

Series J [⊙] Rating Information (see page 8-8)	
Phase 1	1kVA-500kVA (Floor Mounted)
Phase 3	S _{DS} =2.00g ; z/h = 1.00 ; I _p = 1.5

①Actual taps may vary based on volts/turn ratio.
 ②Wall designations for units having standard features.
 ③Ventilated transformers drip shields are UL listed for outdoor use.
 ④Encapsulated transformers are UL listed for indoor/outdoor use. 15kVA with R taps also available in ventilated enclosure.

⑤See table on page 8-8 for available kits.
 ⑥Items marked floor and wall can be wall mounted with optional wall bracket that may be identified with “W” suffix on catalog number. Wall mounting brackets will not be available for Series J 75kVA with copper winding options.

⑦Reduced capacity 1-phase tap— When utilizing 1-phase tap at 5%, the 3-phase load is reduced to 85% max. (5% reduction on 3 coils). 10% of rated kVA absolute maximum (evenly balanced on each side of lighting tap). When utilizing 1-phase tap at 10%, the 3-phase load is reduced to 70% max. (10% reduction on 3 coils).
 ⑧Results are filed with OSHPD per OSP-0109-10.
 ⑨Series H Tap Standard.
 ⑩Series J Tap Standard.

Distribution Dry Type Transformers

Three Phase

Selection

kVA	Catalog Number	Taps ^①	Temperature Rise	Insulation	Mounting Type ^{②③④}	Drip Shield Provided ^⑤	Enclosure Style ^⑥	Optional Modifications
600 Volts Δ Primary, 208Y/120 Volts Secondary								
3	3G3R003	R	135° C	180° C	Wall	No	Encapsulated – NEMA 3R	1, 2, 3
6	3G3R006	R	135° C	180° C	Wall	No		1, 2, 3
9	3G3R009	R	135° C	180° C	Wall	No		1, 2, 3
15	3G3R015	R	135° C	180° C	Wall	No		1, 2, 3
15	3G3T015D16	Y ^⑦ , T ^⑧	150° C	220° C	Floor & Wall	Yes	Ventilated – NEMA 3R	1, 2, 3, 4, 6
30	3G3T030D16	Y ^⑦ , T ^⑧	150° C	220° C	Floor & Wall	Yes		1, 2, 3, 4, 6
45	3G3T045D16	Y ^⑦ , T ^⑧	150° C	220° C	Floor & Wall	Yes		1, 2, 3, 4, 6
75	3G3T075D16	Y ^⑦ , T ^⑧	150° C	220° C	Floor	Yes	Ventilated – NEMA 3R	1, 2, 3, 6
112.5	3G3T112D16	Y ^⑦ , T ^⑧	150° C	220° C	Floor	Yes		1, 2, 3, 6
150	3G3T150D16	Y ^⑦ , T ^⑧	150° C	220° C	Floor	Yes		1, 2, 3, 6
225	3G3T225D16	Y ^⑦ , T ^⑧	150° C	220° C	Floor	Yes		1, 2, 3, 6
300	3G3T300D16	Y ^⑦ , T ^⑧	150° C	220° C	Floor	Yes		1, 2, 3, 6
500	3G3T500D16	Y ^⑦ , T ^⑧	150° C	220° C	Floor	Yes		1, 2, 3, 6

600 Volts Δ Primary, 480Y/277 Volts Secondary								
3	3G5R003	R	135° C	180° C	Wall	No	Encapsulated – NEMA 3R	1, 2, 3
6	3G5R006	R	135° C	180° C	Wall	No		1, 2, 3
9	3G5R009	R	135° C	180° C	Wall	No		1, 2, 3
15	3G5R015	R	135° C	180° C	Wall	No		1, 2, 3
15	3G5T015D16	Y ^⑦ , T ^⑧	150° C	220° C	Floor & Wall	Yes	Ventilated – NEMA 3R	1, 2, 3, 4, 6
30	3G5T030D16	Y ^⑦ , T ^⑧	150° C	220° C	Floor & Wall	Yes		1, 2, 3, 4, 6
45	3G5T045D16	Y ^⑦ , T ^⑧	150° C	220° C	Floor & Wall	Yes		1, 2, 3, 4, 6
75	3G5T075D16	Y ^⑦ , T ^⑧	150° C	220° C	Floor	Yes	Ventilated – NEMA 3R	1, 2, 3, 6
112.5	3G5T112D16	Y ^⑦ , T ^⑧	150° C	220° C	Floor	Yes		1, 2, 3, 6
150	3G5T150D16	Y ^⑦ , T ^⑧	150° C	220° C	Floor	Yes		1, 2, 3, 6
225	3G5T225D16	Y ^⑦ , T ^⑧	150° C	220° C	Floor	Yes		1, 2, 3, 6
300	3G5T300D16	Y ^⑦ , T ^⑧	150° C	220° C	Floor	Yes		1, 2, 3, 6
500	3G5T500D16	Y ^⑦ , T ^⑧	150° C	220° C	Floor	Yes		1, 2, 3, 6

Dual Purpose Auto Transformers^⑨

kVA		Catalog Number	Taps ^①	Temperature Rise	Insulation	Mounting Type ^②	Drip Shield Required ^③	Enclosure Style ^④	Optional Modifications
600V Pri 480V Sec	480V Pri 380V Sec								
600 Volts Primary, 480 Volts Secondary 3Ø 60 Hz OR—480 Volts Primary 380 Volts Secondary 3Ø 50/60 Hz Alternate Rating									
15	12	3G4N015A	N	80° C	130° C	Wall	No	Encapsulated – NEMA 3R	—
30	24	3G4N030A	N	115° C	180° C	Wall	No		—
45	36	3G4N045A	N	150° C	220° C	Floor & Wall	Yes	Ventilated – NEMA 3R	4, 5
75	60	3G4N075A	N	150° C	220° C	Floor & Wall	Yes		4, 5
112.5	90	3G4N112A	N	150° C	220° C	Floor & Wall	Yes		4, 5
150	120	3G4N150A	N	150° C	220° C	Floor & Wall	Yes		4, 5
225	180	3G4N225A	N	150° C	220° C	Floor & Wall	Yes		4, 5
300	240	3G4N300A	N	150° C	220° C	Floor	Yes		5
500	400	3G4N500A	N	150° C	220° C	Floor	Yes	5	

Optional Modifications Table (Contact Sales office for List Price)

Optional (commonly used) Modifications	Catalog Suffix Code
1a. 115° C Rise	F
1b. 80° C Rise	B
2. Electrostatic Shield	ES
3. Copper Windings	C
4. Wall Mounting Brackets	W
6. Low noise - XdB below std.	LNx

Taps

Description	Designation
None	N
2-5% FCBN	R
2-5% (1 FCAN, 1 FCBN)	S
2-2.5% FCBN	U
6-2.5% (2 FCAN, 4 FCBN)	Y

① Actual taps may vary based on volts/turn ratio.
 ② Wall designations for units having standard features.
 ③ Ventilated transformers drip shields are UL listed for outdoor use.
 ④ Encapsulated transformers are UL listed for indoor/outdoor use.

⑤ If used on unbalanced loads, these auto transformers will need to be used on a 4-wire system with the supply neutral connected to the transformer. If used on motor loads, then they may be used on a 3-wire system without a neutral or fourth wire. Review in NEC 450-4 and 450-5.
 ⑥ Items marked floor and wall can be wall mounted with optional wall bracket that may be identified

with "W" suffix on catalog number. Wall mounting brackets will not be available for Series J 75kVA with copper winding options. See pages 8-8 and 8-27 for details.
 ⑦ Series H Tap Standard.
 ⑧ Series J Tap Standard.
 ⑨ See table on page 8-8 for available kits.

Distribution Dry Type Transformers

Motor Drive Isolation

For industrial and commercial applications with SCR-controlled adjustable speed motor drives, and AC adjustable frequency or DC drives.

Designed for use with motor drives, the drive isolation transformer must isolate the motor from the line and handle the added loads of the drive-created harmonics.

Drive isolation transformers are engineered for both AC adjustable frequency and DC motor drives.

They are specifically designed to accommodate the electrical and mechanical stresses, regenerative current reversals and frequent short circuits, inherent in severe drive duty cycles.

Three Phase 60HZ Motor Drive Isolation Transformers

Motor kVA	Catalog H.P. ④	Standard Number	Taps ①	Rise	Insulation	Mounting Type ③	Drip Shield Required ②	Optional Modifications
7.5	3 & 5	DT () 007	S	135° C	180° C	Floor & Wall	No	1, 2, 3
11	7.5	DT () 011	S	135° C	180° C	Floor & Wall	No	1, 2, 3
14	10	DT () 014	S	150° C	220° C	Floor & Wall	Yes	1, 2, 3, 4, 5, 6
20	15	DT () 020	S	150° C	220° C	Floor & Wall	Yes	1, 2, 3, 4, 5, 6
27	20	DT () 027	S	150° C	220° C	Floor & Wall	Yes	1, 2, 3, 4, 5, 6
34	25	DT () 034	S	150° C	220° C	Floor & Wall	Yes	1, 2, 3, 4, 5, 6
40	30	DT () 040	S	150° C	220° C	Floor & Wall	Yes	1, 2, 3, 4, 5, 6
51	40	DT () 051	S	150° C	220° C	Floor & Wall	Yes	1, 2, 3, 4, 5, 6
63	50	DT () 063	S	150° C	220° C	Floor & Wall	Yes	1, 2, 3, 4, 5, 6
75	60	DT () 075	S	150° C	220° C	Floor	Yes	1, 2, 3, 5, 6
93	75	DT () 093	S	150° C	220° C	Floor	Yes	1, 2, 3, 5, 6
118	100	DT () 118	S	150° C	220° C	Floor	Yes	1, 2, 3, 5, 6
145	125	DT () 145	S	150° C	220° C	Floor	Yes	1, 2, 3, 5, 6
175	150	DT () 175	S	150° C	220° C	Floor	Yes	1, 2, 3, 5, 6
220	200	DT () 220	S	150° C	220° C	Floor	Yes	1, 2, 3, 5, 6
275	250	DT () 275	S	150° C	220° C	Floor	Yes	1, 2, 3, 5, 6
330	300	DT () 330	S	150° C	220° C	Floor	Yes	1, 2, 3, 5, 6
440	400	DT () 440	S	150° C	220° C	Floor	Yes	1, 2, 3, 5, 6
550	500	DT () 550	S	150° C	220° C	Floor	Yes	1, 2, 3, 5, 6
660	600	DT () 660	S	150° C	220° C	Floor	Yes	1, 2, 3, 5, 6

DT () Code	Primary Volts	Secondary Volts
18	208 Delta	208Y/120
20	208 Delta	230Y/133
21	208 Delta	460Y/266
22	230 Delta	230Y/133
24	230 Delta	460Y/266
30	380 Delta	460Y/266
42	460 Delta	230Y/133
44	460 Delta	460Y/266
45	460 Delta	380Y/220
52	575 Delta	230Y/133
54	575 Delta	460Y/266

Motor Drive Isolation Optional Modifications	Catalog Suffix Code
1a. 115° C Rise	F
1b. 80° C Rise	B
2. Electrostatic Shield	ES
3. Copper Windings	C
4. Wall Mounting Brackets	W
5. Drip Shields/Weather Shields	DS
6. Thermal Switches	TS

(Contact Sales office for List Price)

① Actual taps may vary based on volts/turn ratio.
 ② For outdoor application. Ventilated transformers requiring drip shields are UL listed for outdoor use. No charge when requested at time of initial project order.

③ Items marked floor and wall can be wall mounted with optional wall bracket identified with "W" suffix on catalog number. See pages 8-8 and 8-27 for details.

④ Refer selection and application guide for additional information on horsepower, Ampere, kVA ratings and applications. Standard taps varies with design volts/turn ratio.

Distribution Dry Type Transformers

Sentron Power Centers

Selection

Economical Space Saving Package

Siemens Sentron Power Center is a pre-wired combination of a primary breaker disconnect, dry type shielded transformer, secondary breaker disconnect and a secondary power panel all in one convenient package.

You save time, space and money by not having to individually assemble, mount and wire these components. Simply add the branch and you're ready to go.

UL-3R Enclosures

All Sentron Power Center enclosures are UL-3R listed for indoor and outdoor use.

Transformer Assembly

Siemens totally encapsulated distribution transformers are designed for general purpose indoor/outdoor operation.

Sentron Power Centers can be installed in a wide variety of atmospheric and environmental conditions. A 180°C, UL recognized insulation system is used with a 115°C temperature rise.

Sentron Power Center units are electrostatically shielded to provide transient voltage protection at no extra cost. All units have 2-5% FCBN taps.

Panel Assembly

The power panel assembly will accommodate one-inch, 1, 2 or 3-pole, common trip, duplex secondary branch circuit breakers, Type Q and QT as well as ground fault circuit breakers. Per UL and NEC requirements, the Sentron Power Center assembly comes fully equipped with primary and secondary main circuit breakers. Branch circuit breakers can be obtained from our local distributor once you have established your branch circuit requirements. All Sentron Power Centers are UL listed for service entrance.

- * Not Seismic rated
- ** Not available for Buy America

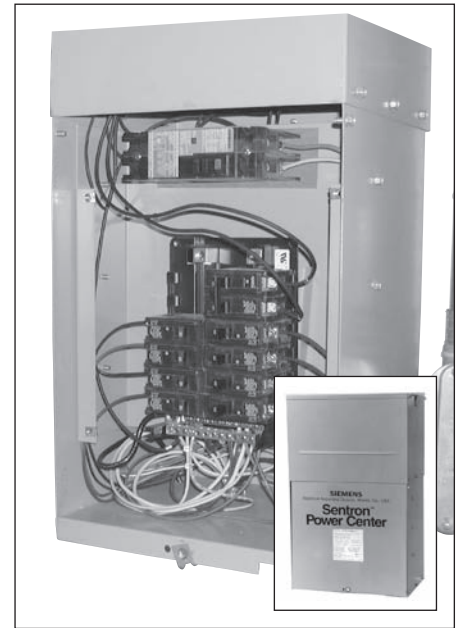

kVA	Catalog Number ^{③⑦}	Maximum Secondary Circuits ^①			Interior Number Reference ^⑤	Approximate Dimensions (in inches)			Approximate Net Weight (lbs.)
		1" Wide	1/2" Wide	2" Wide		Height	Width	Depth	
		120V (1-Pole)	120V (1-Pole)	240V (2-pole)					

480 Volts Primary, 240/120 Volts Secondary — Single Phase^② — Sentron Power Centers^③

5.0	1LPC005	8	16	4	I1224ML1100	32.13	13.25	7.63	120
7.5	1LPC007	8	16	4	I1224ML1100	32.13	15.88	11.00	160
10.0	1LPC010	8	16	4	I1224ML1100	34.38	15.88	11.00	185
15.0	1LPC015	12	24	6	I1224L1125CU	34.38	17.13	12.38	240
25.0	1LPC025	20	40	10	I2440L1200CU	41.88	17.88	13.50	330

kVA	Catalog Number ^{③⑦⑧}	Maximum Secondary Circuits ^①			Interior Number Reference ^⑤	Approximate Dimensions (in inches)			Approximate Net Weight (lbs.)
		1" Wide	1/2" Wide	3" Wide		Height	Width	Depth	
		120V (1-Pole)	120V (1-Pole)	208V (3-pole)					

480 Volts Δ Primary, 208Y/120 Volts Secondary — Three Phase — Sentron Power Centers^③

9.0	3LPC009	12	24	4	PI1836L3200CUB	33.75	22.13	7.63	255
15.0	3LPC015	12	24	4	PI1836L3200CUB	35.13	22.13	12.38	385
22.5	3LPC022	18	36	6	PI2442L3200CUB	38.25	30.25	13.38	535
30.0	3LPC030	24	42	8	PI3054L3200CUB	43.75	33.00	13.75	680

Circuit Breaker Data for Plug-In Sentron Power Centers

480 Volts to 240/120 Volts — Single Phase

kVA	480 Volts Primary Breaker ^{①⑤⑥}	240/120 Volts Secondary Main	Maximum Rating of Secondary Breakers
5.0	ED42B025L (25A)	Q225 (25A)	20 Amps
7.5	ED42B025L (25A)	Q240 (40A)	30 Amps
10.0	ED42B035L (35A)	Q250 (50A)	40 Amps
15.0	ED42B050L (50A)	Q270 (70A)	60 Amps
25.0	ED42B090L (90A)	Q2125 (125A)	100 Amps

480 Volts Δ to 208Y/120 Volts — Three Phase

kVA	480 Volts Primary Breaker ^{①⑤⑥}	208Y/120 Volts Secondary Main	Maximum Rating of Secondary Breakers
9.0	ED43B025L (25A)	Q330 (30A)	25 Amps
15.0	ED43B040L (40A)	Q350 (50A)	40 Amps
22.5	ED43B070L (70A)	Q370 (70A)	60 Amps
30.0	ED43B090L (90A)	Q3100 (100A)	80 Amps

① Primary breaker has lineside lug for customer connection.
 ② 18,000 Amps RMS Symmetrical Interrupting Capacity.
 ③ Sentron Power Centers are NEMA 3R for outdoor application and may be ordered with "SS" suffix for 304 stainless steel enclosure. For 316 stainless steel add suffix SS316.

④ Secondary branch breakers are not included and must be ordered separately.
 ⑤ Primary and secondary main breakers are included and are factory installed.
 ⑥ ED frame breakers furnished are rated 18000 AIC and are sufficient for fault current of transformer. No other breakers are currently approved for use.

⑦ Copper windings are standard on 1LPC005 and 3LPC009. Add CU to other partnumber to get copper windings.
 ⑧ CU and CUB interiors have tin plated copper bus. 1-Phase 5 thru 10kVA have aluminum bus. CUB refers to OEM interior verses CU un-assembled interior.

Distribution Dry Type Transformers

Sentron Power Centers

Selection

Bolt-on Breaker Option

The same economical space saving package, NEMA 3R rated enclosure, and UL listed transformer of the original Sentron Power Center but now available with more robust BOLT-ON BREAKERS.

Panel Assembly

This version of the Sentron Power Center uses our UL Recognized P1 Lighting Panel interior with the following ratings & features:

- 200 kA Short Circuit rating
- 240 Volts maximum (when using type BL branch devices)
- 250 Amps maximum
- Copper bus
- 18 circuit panel for 15kVA and below
- 30 circuit panel for designs above 15kVA

The power panel assembly will accommodate one-inch, 1, 2, or 3-pole type BL, BLH, HBL branch Breakers, to include the BL family of AFCI, GFCI, Ground Fault, Switching Neutrals, HID Lighting, Tungsten Lighting, and Molded Case Switches.

The Sentron Power Center assembly comes fully equipped with transformer primary and secondary main circuit breakers. Branch circuit breakers can be obtained from our local distributor once you have established your branch circuit requirements. All Sentron Power Centers are UL listed for service entrance applications.

* Not Seismic rated

** Buy America may be available on some models. Catalog numbers will end in "BA." Lead times will be affected. Please contact Customer Support for more information.



Voltage rating: 480 - 240/120, Single Phase^②, Sentron Power Center^⑤

kVA	Catalog Number ^③	Maximum Secondary Circuits ^⑥		Interior Part Number	Approximate Dimensions (inches)			Approximate Weight (lbs.)
		1" Wide	2" Wide		Height	Width	Depth	
5	1LPC005JA ^④	16	8	K11D255001	38.00	15.88	11.00	165
7.5	1LPC007JA ^④	16	8	K11D255001	38.00	15.88	11.00	165
10	1LPC010JA ^④	16	8	K11D255001	38.00	17.13	12.38	240
15	1LPC015JA ^④	16	8	K11D255001	38.00	17.13	12.38	240
25	1LPC025JA ^④	28	14	K11D255002	45.19	17.88	13.50	330

Voltage rating: 480 Delta - 208Y/120, Three Phase, Sentron Power Center^④

kVA	Catalog Number ^③	Maximum Secondary Circuits ^{⑥⑦}		Interior Part Number	Approximate Dimensions (inches)			Approximate Weight (pounds)
		1" Wide	2" Wide		Height	Width	Depth	
9	3LPC009JA ^②	15	7	K11D255201	33.75	22.13	7.63	255
15	3LPC015JA ^②	15	7	K11D255201	35.13	22.13	12.38	385
22.5	3LPC022JA ^②	27	13	K11D255202	43.75	33.00	13.75	680
30	3LPC030JA ^②	27	13	K11D255202	43.75	33.00	13.75	680

Circuit Breaker Data for Bolt-on Sentron Power Centers

For Single Phase Sentron Power Centers

kVA	Transformer Primary Breaker ^{①③⑥}	Panel Secondary Main Breaker	Maximum rating of Branch Breakers (Amps)
5	ED42B025L (25A)	B230H (30A)	20
7.5	ED42B025L (25A)	B240H (40A)	30
10	ED42B035L (35A)	B250H (50A)	40
15	ED42B050L (50A)	B270 (70A)	60
25	ED42B090L (90A)	B2125 (125A)	100

For Three Phase Sentron Power Centers

kVA	Transformer Primary Breaker ^{①③⑥}	Panel Secondary Main Breaker	Maximum rating of Branch Breakers (Amps)
9	ED43B025L (25A)	B330H (30A)	25
15	ED43B040L (40A)	B350H (50A)	40
22.5	ED43B070L (70A)	B370 (70A)	60
30	ED43B090L (90A)	B3100 (100A)	80

① Primary breaker has lineside lug for customer connection.
 ② 18,000 Amps RMS Symmetrical Interrupting Capacity.
 ③ Sentron Power Centers are NEMA 3R for outdoor application and may be ordered with "SS" suffix for 304 stainless steel enclosure. For 316 stainless steel add suffix SS316.

④ Secondary branch breakers are not included and must be ordered separately.
 ⑤ Primary and secondary main breakers are included and are factory installed.
 ⑥ ED frame breakers furnished are rated 18000 AIC and are sufficient for fault current of transformer. No other breakers are currently approved for use.

⑦ Standard windings are aluminum. Add "CU" at end for copper windings. Contact customer support for assistance.
 ⑧ Excluding Secondary Main Breaker that takes up 2 poles.
 ⑨ Excluding Secondary Main Breaker that takes up 3 poles.

Transformers

DOE 2016 Efficiency Standards

The Department of Energy (DOE) 10 CFR 431 has released new efficiency standards which will be put into effect January 1, 2016. These standards surpass and supersede NEMA TP1 efficiency standards. All low-voltage dry-type three-phase ventilated transformers from 15 kVA through 1000kVA must be manufactured to these standards after January 1, 2016. DOE 2016 standards also apply to Harmonic Mitigating Transformers (See pages 8-19 - 8-20).

Transformers manufactured to DOE 2016 efficiencies must meet efficiency levels with a 35% load and temperature of 75°C. Transformers with DOE 2016 standards have grain-oriented, non-aging silicon steel cores. DOE 2016 standards do not apply to single phase, encapsulated, motor drive isolation, and auto transformers.

High Efficiency Transformers

Single Phase		Three Phase	
kVA	TP1 Efficiency	kVA	DOE 2016 Efficiency
15	97.70%	15	97.89%
25	98.00%	30	98.23%
37.5	98.20%	45	98.40%
50	98.30%	75	98.60%
75	98.50%	112.5	98.74%
100	98.60%	150	98.83%
167	98.70%	225	98.94%
250	98.80%	300	99.02%
333	98.90%	500	99.14%
		750	99.23%
		1000	99.28%

NEMA TP1 Efficiency Standards

NEMA TP1 will still be a valid efficiency standard for single phase transformers after January 1, 2016. The TP1 designs use high grade electrical steel and other features to lower flux density and reduce losses especially at average 35% loading where the TP1 measurements apply. The core construction employs the use

of high quality grain-oriented, non-aging silicon steel with high permeability, low hysteresis, and low eddy current losses. These characteristics are required to achieve the TP1 efficiency levels. Core laminations must be tightly assembled enabling magnetic flux densities to be kept well below the saturation point.

Description

The Sentron Harmonic Mitigating Transformers (HMTs) are designed to meet the needs of modern power distribution systems that contain a large percentage of non-linear equipment that produces harmonics. Some examples of this type of equipment are computers, printers, fax machines, scanners, copiers, uninterruptible power supplies, ballast and variable frequency drives (VFD). This type of equipment generates harmonic voltages and currents because they contain AC to DC power conversion rectifiers. Harmonic voltages and currents can cause a variety of problems ranging from poor power factor, voltage distortion, capacitor resonance and motor failures to overloaded transformers and conductors.

The Sentron HMTs are specially designed to operate under high non-linear load conditions and have the additional benefit of improving the overall power system reliability.

Application

One of the most effective ways to eliminate power system harmonics is to use a technique known as "phase shifting." In this method power system harmonics are eliminated by pairing together harmonics that have 180° relative angular displacement, which causes them to cancel one another out. This can be accomplished by a variety of means:

Single Output Harmonic Mitigating Transformer (0° or -30° primary-secondary angular displacement)

■ The primary of this transformer has a delta connection and its secondary has a special double winding connection. Although there is only one secondary three phase output, the 3rd, 9th and 15th harmonic currents are prevented from circulating in the primary windings by canceling their magnetic fluxes at low impedance with the double winding secondary, reducing voltage distortions to the loads.

- When two transformers with this type of connection, 0° and -30° displacement, are used in parallel, the 3rd, 9th and 15th harmonic currents are canceled as previously described, and additionally the 5th and 7th harmonic currents are cancelled in the electrical supply common to both transformers due to their relative 30° phase shift.
- If a single harmonic mitigating transformer (0°) is used in an existing or new system utilizing standard delta-wye transformers (-30°), the 5th and 7th harmonic currents originating from the HMT transformer (0°) will attempt to cancel the 5th and 7th harmonic currents originating from the standard delta-wye transformer (-30°). This reduces the overall 5th and 7th harmonics present in the system, with the actual reduction dependent on the magnitudes of the secondary loads.

Benefits

Elimination of undesirable harmonics by using the Siemens Sentron HMTs is an effective solution to the power quality problems encountered by today's power system professionals. By treating the harmonics at their source, using advanced technology, installation problems can be avoided and overall system reliability improved. The Sentron HMT product line provides many far reaching benefits such as lower operating cost, improved operating efficiency, reduced down-time due to outages caused by nuisance tripping, and increased equipment life due to low-voltage distortions.

Design and Construction Features

The Sentron Harmonic Mitigating Transformers comply with all applicable ANSI/IEEE standards including C57.12.91, C57.96, C57.110, CSA # C22.2 No. 47 (CUL), UL506, UL1561 as well as NEMA ST-20. The design life is 25 years at 150 degree C rise, 30 years at 115C rise and 40 years for 80C rise models. Approvals and listings include UL, CSA, with CE approval available when requested. The Sentron HMTs have capability of K-factor up to K-13, which is achieved by harmonic cancellations in the secondary and low flux density design for protection against heat in place of design enlargement protection only. Both copper and aluminum coil windings are available and full width copper foil electrostatic shield is standard. Additional shield options are available for higher noise attenuation requirements. All HMTs have 150C rise with optional 130C, 115C and 80C winding rise designs available. All designs include vacuum impregnated polyester resin encapsulation of windings and NEMA 3R enclosures. A neutral sized at 200% of the ampacity of the secondary phase conductors for extra protection against triplers and unbalanced single phase loads. The Sentron HMT designs have DOE 2016 energy efficient rating equal to that of a non K-Factor rated transformer. Siemens HMT designs have DOE 2016 efficiency levels at 35% load @ ref temp. 75 degree C.

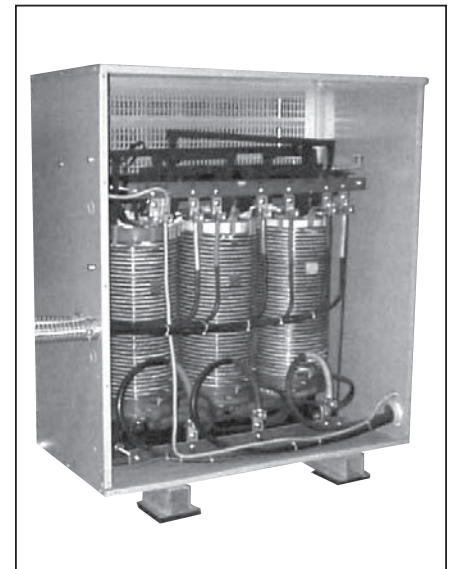

Transformers

Sentron Harmonic Mitigating Transformers (HD1)

Selection

Catalog Number Coding:

Single output (1 secondary) = HD1,
Phase Shift Options: HD1 followed by > (00) or (30) degree.
HMT, 480 Volt Primary 208Y/120 Volt Secondary (3F3)–150C
(standard), 115C and 80C Winding Rise displayed on this page.
HMTs are also available with 480–480Y/277 (3F5), 208–
208Y/120 (3B3), 208–480Y/277 (3B5).

Standard Features Include:

- K-13 Load profile rating.
- DOE 2016 Efficiencies at 35% load.
- (C) Copper windings or Aluminum windings (no suffix code)®
- (ES) Electrostatic shield.
- 150 C Winding rise.

Changes after January 1, 2016: 2 output, 15 & 45 deg Lag & 130 deg C temp rise will no longer be standard. They can be provided with a special quote from MAP.

kVA	150C (Std) Rise HMT Catalog Number ^①	115C Rise HMT Catalog Number ^①	80C Rise HMT Catalog Number ^①	Secondary Configuration		Enclosure Style	Optional HMT Modifications
				Outputs	Phase Shift		
15	3F3Y015CHD100	3F3Y015FCHD100	3F3Y015BCHD100	1	Zero Degree	Vented	A,B,C,D,E,F,G
15	3F3Y015CHD130	3F3Y015FCHD130	3F3Y015BCHD130	1	30 Deg Lagging	Vented	A,B,C,D,E,F,G
30	3F3Y030CHD100	3F3Y030FCHD100	3F3Y030BCHD100	1	Zero Degree	Vented	A,B,C,D,E,F,G
30	3F3Y030CHD130	3F3Y030FCHD130	3F3Y030BCHD130	1	30 Deg Lagging	Vented	A,B,C,D,E,F,G
45	3F3Y045CHD100	3F3Y045FCHD100	3F3Y045BCHD100	1	Zero Degree	Vented	A,B,C,D,E,F,G
45	3F3Y045CHD130	3F3Y045FCHD130	3F3Y045BCHD130	1	30 Deg Lagging	Vented	A,B,C,D,E,F,G
75	3F3Y075CHD100	3F3Y075FCHD100	3F3Y075BCHD100	1	Zero Degree	Vented	A,B,C,D,E,F,G
75	3F3Y075CHD130	3F3Y075FCHD130	3F3Y075BCHD130	1	30 Deg Lagging	Vented	A,B,C,D,E,F,G
112.5	3F3Y112CHD100	3F3Y112FCHD100	3F3Y112BCHD100	1	Zero Degree	Vented	A,B,C,D,E,F,G
112.5	3F3Y112CHD130	3F3Y112FCHD130	3F3Y112BCHD130	1	30 Deg Lagging	Vented	A,B,C,D,E,F,G
150	3F3Y150CHD100	3F3Y150FCHD100	3F3Y150BCHD100	1	Zero Degree	Vented	A,B,C,D,E,F,G
150	3F3Y150CHD130	3F3Y150FCHD130	3F3Y150BCHD130	1	30 Deg Lagging	Vented	A,B,C,D,E,F,G
225	3F3Y225CHD100	3F3Y225FCHD100	3F3Y225BCHD100	1	Zero Degree	Vented	A,B,C,D,E,F,G
225	3F3Y225CHD130	3F3Y225FCHD130	3F3Y225BCHD130	1	30 Deg Lagging	Vented	A,B,C,D,E,F,G
300	3F3Y300CHD100	3F3Y300FCHD100	3F3Y300BCHD100	1	Zero Degree	Vented	A,B,C,D,E,F,G
300	3F3Y300CHD130	3F3Y300FCHD130	3F3Y300BCHD130	1	30 Deg Lagging	Vented	A,B,C,D,E,F,G
500	3F3Y500CHD100	3F3Y500FCHD100	3F3Y500BCHD100	1	Zero Degree	Vented	C,D,E,F,G
500	3F3Y500CHD130	3F3Y500FCHD130	3F3Y500BCHD130	1	30 Deg Lagging	Vented	C,D,E,F,G

Optional Modifications Table for HMTs

<p>Sound Level</p> <p>A LN3= (3dB below NEMA standard)</p> <p>B LN5= (5dB below NEMA standard)</p> <p>Attenuation—Single shield—60dB Common Mode Std.</p> <p>C ES2= Double shield—80dB Common Mode > ^②</p> <p>Filtering & Attenuation</p> <p>E TV= Secondary side TVSS (100kA & 200kA available) with common mode noise attenuation</p> <p>F TB= Terminal Block</p>	<p>Thermal Sensors 170° C= (TS7), 185° C= (TS8) or 200° C= (TS0)</p> <p>G TS7 = 1 sensor center coil</p> <p>G TS72 = 2 sensors center coil</p> <p>G TS76 = 6 sensors, (2) on each coil</p> <p>G TS8 = 1 sensor center coil</p> <p>G TS82 = 2 sensors center coil</p> <p>G TS86 = 6 sensors, (2) on each coil</p> <p>G TS0 = 1 sensor center coil</p> <p>G TS02 = 2 sensors center coil</p> <p>G TS06 = 6 sensors, (2) on each coil</p>
---	--

① Contact Sales Office for pricing.

② ES2
Common Mode:
100dB: Between 60 Hz – 1 kHz
90 dB: Between 1 kHz – 10 kHz
80dB: Between 10 kHz – 1000 kHz

Transverse Mode:
10dB: @ 10kHz
20dB: @ 100 kHz
40db: @ 1000 kHz

③ Catalog Numbers shown with “C” include Copper windings. Remove “C” for Aluminum windings. COMPAS will configure Aluminum version unless Copper windings are selected.

Warehouse Stock Transformers

Warehouse Stock

Selection



Buck-Boost Application Description and Selection

The Buck-Boost Transformer has four separate windings, two-windings in the primary and two-windings in the secondary. The unit is designed for use as an isolation (or insulating) transformer or as an autotransformer. As an autotransformer the unit can be connected to Buck (decrease) or Boost (increase) a supply voltage. When connected in either the Buck or Boost mode, the unit is no longer an isolation (or insulating) transformer but is an autotransformer. Units are designed for 60Hz applications (50Hz units available upon request).

Autotransformers are more economical and physically smaller than equivalent two-winding transformers and are designed to carry the same function as two-winding transformers, with the exception of isolating two circuits. Since autotransformers may transmit line disturbances directly, they may be prohibited in some areas by local building codes. Before applying them, care should be taken to assure that they are acceptable according to local code.

NOTE: Autotransformers are not used in closed delta connections as they introduce into the circuit a phase shift which makes them uneconomical.

As isolation (or insulating) transformers these units can accommodate a high voltage of 120, 240 or 480 volts. For units with two 12 volt secondaries, two 16 volt secondaries, or two 24 volt secondaries, the output can be wired for either secondary voltage, or for 3-wire secondary. The unit is rated (kVA) as any conventional transformer.

Operation

Electrical and electronic equipment is designed to operate on a standard supply voltage. When the supply voltage is constantly too high or too low, (usually greater than $\pm 5\%$), the equipment fails to operate at maximum efficiency. A Buck-Boost transformer is a simple and economical

means of correcting this off-standard voltage up to $\pm 20\%$. A Buck-Boost transformer will NOT, however, stabilize a fluctuating voltage. Buck-Boost transformers are suitable for use in a three phase autotransformer bank in either direction to supply 3-wire loads. They are also suitable for use in a three phase autotransformer bank which provides a neutral return for unbalanced current. They are NOT suitable for use in a three phase autotransformer bank to supply a 4-wire unbalanced load when the source is a 3-wire circuit.

Construction

Buck-Boost Transformers are contained within a NEMA 3R, non-ventilated weather-proof enclosure. Wiring compartments are located at the bottom. Core and coil assemblies are encapsulated. Isolation (or insulating) system temperature is 130° C and the winding temperature rise is 95° C for units up through 1 kVA. Isolation (or insulating) system temperature is 180° C and the winding temperature rise is 135° C for units 1.5 kVA and above.

How To Select The Proper Transformer

To select the proper Transformer for Buck-Boost applications, determine:

1. Input line voltage — The voltage that you want to buck (decrease) or boost (increase). This can be found by measuring the supply line voltage with a voltmeter.
2. Load voltage — The voltage at which your equipment is designed to operate. This is listed on the nameplate of the load equipment.
3. Load kVA or Load Amps — You do not need to know both — one or the other is sufficient for selection purposes. This information usually can be found on the nameplate of the equipment that you want to operate.

4. Number of phases — Single or three phase line and load should match because a transformer is not capable of converting single to three phase. It is however a common application to make a single phase transformer connection from a three phase supply by use of two legs of the three phase supply circuit. Care must always be taken not to overload the leg of the three phase supply. This is particularly true in a Buck-Boost application because the supply must provide for the load kVA, not just the nameplate rating of the Buck-Boost transformer.
5. Frequency — The supply line frequency must be the same as the frequency of the equipment to be operated — either 50 or 60 cycles.

How To Use Selection Charts

1. Choose the selection table with the correct number of phases for single or three phase applications.
2. Line/Load voltage combinations are listed across the top of the selection table. Select a line/load voltage combination which comes closest to matching your applications.
3. Follow the selected column down until you find either the kVA or load amps of your application. If you do not find the exact value, go on the next highest rating.
4. Now follow across the table to the far left-hand side to find the catalog number and the kVA of the transformer you need.
5. Follow the column of your line/load voltage to the bottom to find the connection diagram for this application.

NOTE: Connection diagrams show low-voltage and high-voltage connection terminals. Either can be input or output depending on Buck or Boost application.
6. In the case of three phase loads either two or three single phase transformers are required as indicated in the "quantity required" line at the bottom of the table. The selection is dependent on whether a Wye connected bank of three transformers with a neutral is required or whether an open Delta connected bank of two transformers for a Delta connected load will be suitable.
7. For line/load voltage not listed on the selection tables, use the pair listed on the table that is slightly above your application for reference. Then apply the first formula at the bottom of the table to determine "new" output voltage. The new kVA rating can be found using the second formula.

Warehouse Stock Transformers

Buck-Boost

Selection

120 × 240 Volts Primary — 12/24 Volts Secondary, 60 Hz, No Taps, Wall Mounted

Single Phase — Table 1		Boosting								Bucking					
Catalog Number*	Line Voltage (Available)	96	100	105	109	189	208	215	220	125	132	229	245	250	252
Insulating Transformer Rating	Load Voltage (Output)	115	120	115	120	208	229	237	242	114	120	208	222	227	240
050BB1224J .050 kVA	kVA	.24	.25	.50	.50	.43	.48	.49	.50	.52	.55	.48	.51	.52	1.05
	Load Amps	2.08	2.08	4.17	4.17	2.08	2.08	2.08	2.08	4.59	4.59	2.29	2.29	2.29	4.38
100BB1224J .100 kVA	kVA	.48	.50	.96	1.00	.87	.95	.99	1.01	1.04	1.10	.95	1.02	1.04	2.10
	Load Amps	4.17	4.17	8.33	8.33	4.17	4.17	4.17	4.17	9.16	9.16	4.58	4.58	4.58	8.75
150BB1224J .150 kVA	kVA	.72	.75	1.44	1.50	1.30	1.43	1.48	1.51	1.55	1.65	1.43	1.53	1.56	3.15
	Load Amps	6.25	6.25	12.50	12.50	6.25	6.25	6.25	6.25	13.75	13.75	6.88	6.88	6.88	13.13
205BB1224J .250 kVA	kVA	1.19	1.25	2.40	2.50	2.17	2.38	2.47	2.52	2.60	2.75	2.38	2.54	2.60	5.25
	Load Amps	10.42	10.42	20.83	20.83	10.42	10.42	10.42	10.42	22.92	22.92	11.46	11.46	11.46	21.88
505BB1224J .500 kVA	kVA	2.37	2.50	4.80	5.00	4.33	4.77	4.94	5.04	5.18	5.50	4.77	5.09	5.20	10.50
	Load Amps	20.83	20.83	41.67	41.67	20.83	20.83	20.83	20.83	45.83	45.83	22.92	22.92	22.92	43.75
705BB1224J .750 kVA	kVA	3.56	3.75	7.19	7.50	6.50	7.15	7.41	7.56	7.77	8.25	7.15	7.63	7.80	15.75
	Load Amps	31.25	31.25	62.50	62.50	31.25	31.25	31.25	31.25	68.75	68.75	34.38	34.38	34.38	65.63
1BB1224J 1.00 kVA	kVA	4.75	5.00	9.58	10.00	8.67	9.53	9.88	10.08	10.36	11.00	9.53	10.17	10.40	21.00
	Load Amps	41.67	41.67	83.33	83.33	41.67	41.67	41.67	41.67	91.66	91.66	45.83	45.83	45.83	87.50
105BB1224J 1.50 kVA	kVA	7.13	7.50	14.38	15.00	13.00	14.30	14.81	15.13	15.54	16.50	14.30	15.26	15.61	31.50
	Load Amps	62.50	62.50	125.00	125.00	62.50	62.50	62.50	62.50	137.50	137.50	68.75	68.75	68.75	131.25
2BB1224J 2.00 kVA	kVA	9.50	10.00	19.17	20.00	17.33	19.07	19.75	20.17	20.72	22.00	19.07	20.35	20.81	42.00
	Load Amps	83.33	83.33	166.66	166.66	83.33	83.33	83.33	83.33	183.33	183.33	91.66	91.66	91.66	175.00
3BB1224J 3.00 kVA	kVA	14.25	15.00	28.75	30.00	26.00	28.60	29.63	30.25	31.08	33.00	28.60	30.53	31.21	63.00
	Load Amps	125.00	125.00	250.00	250.00	125.00	125.00	125.00	125.00	275.00	275.00	137.50	137.50	137.50	262.50
5BB1224J 5.00 kVA	kVA	23.75	25.00	47.92	50.00	43.33	47.67	49.37	50.42	51.79	55.00	47.67	50.88	52.02	105.00
	Load Amps	208.33	208.33	416.66	416.66	208.33	208.33	208.33	208.33	458.33	458.33	229.17	229.17	229.17	437.50
Connection Diagram (pg. 8-25)		2	2	1	1	4	4	4	4	4	1	4	4	4	3

Three Phase — Table 2		Boosting								Bucking					
Catalog Number*	Line Voltage (Available)	189Y/ 109	195Y/ 113	200Y/ 115	208Y/ 120	416Y/ 240	416Y/ 240	189	208	220	218	229	250	255	264
Insulating Transformer Rating	Load Voltage (Output)	208Y/ 120	234Y/ 135	240Y/ 139	229Y/ 132	458Y/ 264	437Y/ 252	208	229	242	208	208	227	232	240
050BB1224J .050 kVA	kVA	1.50	.84	.86	1.65	1.65	3.15	.75	.83	.87	1.58	.83	.90	.92	.95
	Load Amps	4.17	2.08	2.08	4.17	2.08	4.17	2.08	2.08	2.08	4.39	2.29	2.29	2.29	2.29
100BB1224J .100 kVA	kVA	3.00	1.69	1.73	3.30	3.30	6.29	1.50	1.65	1.75	3.15	1.65	1.80	1.84	1.90
	Load Amps	8.33	4.17	4.17	8.33	4.17	8.33	4.17	4.17	4.17	8.75	4.58	4.58	4.58	4.58
150BB1224J .150 kVA	kVA	4.50	2.54	2.60	4.96	4.96	9.44	2.26	2.48	2.62	4.73	2.48	2.71	2.76	2.86
	Load Amps	12.50	6.25	6.25	12.50	6.25	12.50	6.25	6.25	6.25	13.13	6.88	6.88	6.88	6.88
205BB1224J .250 kVA	kVA	7.50	4.22	4.33	8.30	8.25	15.75	3.75	4.13	4.37	7.88	4.13	4.50	4.61	4.76
	Load Amps	20.83	10.42	10.42	20.83	10.42	20.83	10.42	10.42	10.42	21.88	11.46	11.46	11.46	11.46
505BB1224J .500 kVA	kVA	15.01	8.44	8.66	16.60	16.50	31.50	7.50	8.26	8.73	15.76	8.26	9.01	9.21	9.53
	Load Amps	41.67	20.83	20.83	41.67	20.83	41.67	20.83	20.83	20.83	43.75	22.92	22.92	22.92	22.92
705BB1224J .750 kVA	kVA	22.52	12.67	12.99	24.90	24.75	47.25	11.26	12.39	13.10	23.64	12.39	13.52	13.82	14.29
	Load Amps	62.50	31.25	31.25	62.50	31.25	62.50	31.25	31.25	31.25	65.63	34.38	34.38	34.38	34.38
1BB1224J 1.00 kVA	kVA	30.02	16.89	17.32	33.20	33.00	63.00	15.01	16.51	17.47	31.52	16.51	18.02	18.42	19.05
	Load Amps	83.33	41.67	41.67	83.33	41.67	83.33	41.67	41.67	41.67	87.50	45.83	45.83	45.83	45.53
105BB1224J 1.50 kVA	kVA	45.03	25.33	25.98	49.80	49.50	94.50	22.52	24.77	26.20	47.28	24.77	27.03	27.63	28.53
	Load Amps	125.00	62.50	62.50	125.00	62.50	125.00	62.50	62.50	62.50	131.25	68.75	68.75	68.75	68.75
2BB1224J 2.00 kVA	kVA	60.06	33.77	34.64	66.40	66.00	126.00	30.02	33.03	34.93	63.05	33.03	36.04	36.84	38.11
	Load Amps	166.67	83.33	83.33	166.67	83.33	166.66	83.33	83.33	83.33	175.00	91.67	91.67	91.67	91.67
3BB1224J 3.00 kVA	kVA	90.07	50.66	51.96	99.59	99.00	189.00	45.03	49.54	52.39	94.57	49.54	54.06	55.25	57.16
	Load Amps	250.00	125.00	125.00	250.00	125.00	250.00	125.00	125.00	125.00	262.50	137.50	137.50	137.50	137.50
5BB1224J 5.00 kVA	kVA	150.11	84.44	86.60	165.99	165.00	318.00	75.05	82.56	87.32	157.62	82.56	90.10	92.09	95.26
	Load Amps	416.67	208.33	208.33	416.67	208.33	416.66	208.33	208.33	208.33	437.50	229.17	229.17	229.17	229.17
Quantity Required		3	3	3	3	3	3	2	2	2	2	2	2	2	2
Connection Diagram (pg. 8-25)		5	6	6	5	8	7	12	12	12	11	12	12	12	12

* All Buck-Boost transformers listed are available for immediate shipment.

• Output voltage for lower input voltage can be found by:
 $\frac{\text{Rated Output Voltage}}{\text{Rated Input Voltage}} \times \text{Input Actual Voltage} = \text{Output New Voltage}$

• Output kVA available at reduced input voltage can be found by:
 $\frac{\text{Actual Input Voltage}}{\text{Rated Input Voltage}} \times \text{Output kVA} = \text{New kVA Rating}$

• Inputs and outputs may be reversed without affecting kVA capacity. See note on page 8-25.

Warehouse Stock Transformers

Buck-Boost

Selection

120 × 240 Volts Primary — 16/32 Volts Secondary, 60 Hz, No Taps, Wall Mounted

Single Phase — Table 3		Boosting								Bucking					
Catalog Number*	Line Voltage (Available)	95	100	105	208	215	215	220	225	135	240	240	245	250	255
Insulating Transformer Rating	Load Voltage (Output)	120	113	119	236	244	229	235	240	120	212	225	230	234	239
050BB1632J .050 kVA	kVA	.19	.36	.37	.37	.38	.72	.73	.73	.42	.37	.75	.77	.78	.80
	Load Amps	1.56	3.12	3.12	1.56	1.56	3.12	3.12	3.12	3.54	1.77	3.33	3.33	3.33	3.33
100BB1632J .100 kVA	kVA	.38	.72	.74	.74	.76	1.44	1.46	1.50	.84	.74	1.50	1.54	1.56	1.60
	Load Amps	3.13	6.25	6.25	3.13	3.13	6.25	6.25	6.25	7.09	3.54	6.66	6.66	6.66	6.66
150BB1632J .150 kVA	kVA	.56	1.06	1.12	1.12	1.14	2.16	2.20	2.26	1.26	1.10	2.26	2.30	2.34	2.40
	Load Amps	4.69	9.38	9.38	4.69	4.69	9.38	9.38	9.38	10.64	5.30	10.02	10.02	10.02	10.02
205BB1632J .250 kVA	kVA	.94	1.78	1.86	1.88	1.91	3.59	3.67	3.75	2.11	1.84	3.75	3.83	3.90	3.98
	Load Amps	7.81	15.63	15.63	7.81	7.81	15.63	15.63	15.63	17.71	8.85	16.67	16.67	16.67	16.67
505BB1632J .500 kVA	kVA	1.88	3.56	3.72	3.75	3.81	7.19	7.34	7.50	4.21	3.68	7.50	7.67	7.80	7.97
	Load Amps	15.63	31.25	31.25	15.63	15.63	31.25	31.25	31.25	35.42	17.71	33.33	33.33	33.33	33.33
705BB1632J .750 kVA	kVA	2.81	5.34	5.58	5.63	5.72	10.78	11.02	11.25	6.32	5.53	11.25	11.50	11.70	11.95
	Load Amps	23.44	46.88	46.88	23.44	23.44	46.88	46.88	46.88	53.13	26.56	50.00	50.00	50.00	50.00
1BB1632J 1.00 kVA	kVA	3.75	7.13	7.44	7.50	7.63	14.38	14.69	15.00	8.43	7.37	15.00	15.33	15.60	15.93
	Load Amps	31.25	62.50	62.50	31.25	31.25	62.50	62.50	62.50	70.83	35.42	66.67	66.67	66.67	66.67
105BB1632J 1.50 kVA	kVA	5.63	10.69	11.16	11.25	11.44	21.56	22.03	22.50	12.64	11.05	22.50	23.00	23.40	23.90
	Load Amps	43.90	93.80	93.80	46.90	46.90	93.80	93.80	93.80	106.30	53.10	100.00	100.00	100.00	100.00
2BB1632J 2.00 kVA	kVA	7.50	14.25	14.88	15.00	15.25	28.75	29.38	30.00	16.86	14.73	30.00	30.67	31.20	31.87
	Load Amps	62.50	125.00	125.00	62.50	62.50	125.00	125.00	125.00	141.70	70.80	133.30	133.30	133.30	133.30
3BB1632J 3.00 kVA	kVA	11.25	21.38	22.31	22.50	22.88	43.13	44.06	45.00	25.29	22.10	45.00	46.00	46.80	47.80
	Load Amps	93.80	187.50	187.50	93.80	93.80	187.50	187.50	187.50	212.50	106.30	200.00	200.00	200.00	200.00
5BB1632J 5.00 kVA	kVA	18.75	35.63	37.19	37.50	38.13	71.88	73.44	75.00	42.15	36.83	75.00	76.67	78.00	79.67
	Load Amps	156.30	312.50	312.50	156.30	156.30	312.50	312.50	312.50	354.20	177.10	333.30	333.30	333.30	333.30
Connection Diagram (pg. 8-25)		2	1	1	4	4	3	3	3	1	4	3	3	3	3

Three Phase — Table 4		Boosting					Bucking					
Catalog Number*	Line Voltage (Available)	183Y/ 106	208Y/ 120	195	208	225	240	245	250	256	265	272
Insulating Transformer Rating	Load Voltage (Output)	208Y/ 120	236Y/ 136	208	236	240	208	230	234	240	234	240
050BB1632J .050 kVA	kVA	1.13	1.28	1.13	.62	1.30	.56	1.33	1.35	1.39	.72	.74
	Load Amps	3.13	3.13	3.13	1.56	3.13	1.56	3.34	3.34	3.34	1.77	1.77
100BB1632J .100 kVA	kVA	2.25	2.55	2.25	1.30	2.60	1.13	2.66	2.70	2.77	1.44	1.48
	Load Amps	6.25	6.25	6.25	3.13	6.25	3.13	6.67	6.67	6.67	3.55	3.55
150BB1632J .150 kVA	kVA	3.38	3.83	3.38	1.95	3.90	1.69	3.98	4.05	4.16	2.15	2.21
	Load Amps	9.38	9.38	9.38	4.69	9.38	4.69	10.00	10.00	10.00	5.31	5.31
205BB1632J .250 kVA	kVA	5.63	6.39	5.63	3.17	6.50	2.81	6.64	6.76	6.93	3.59	3.68
	Load Amps	15.63	15.63	15.63	7.81	15.63	7.81	16.67	16.67	16.67	8.85	8.85
505BB1632J .500 kVA	kVA	11.26	12.77	11.26	6.33	12.99	5.63	13.28	13.50	13.86	7.17	7.36
	Load Amps	31.25	31.26	31.25	15.63	31.25	15.63	33.33	33.33	33.33	17.69	17.71
705BB1632J .750 kVA	kVA	16.89	19.16	16.89	9.50	19.49	8.44	19.92	20.26	20.78	10.76	11.04
	Load Amps	46.88	46.88	46.88	23.44	46.88	23.44	50.00	50.00	50.00	26.54	26.56
1BB1632J 1.00 kVA	kVA	22.52	25.55	22.52	12.67	25.98	11.26	26.56	27.02	27.71	14.34	14.72
	Load Amps	62.50	62.50	62.50	31.25	62.50	31.25	66.67	66.67	66.67	35.39	35.42
105BB1632J 1.50 kVA	kVA	33.77	38.32	33.77	19.00	38.97	16.89	39.84	40.53	41.57	21.52	22.08
	Load Amps	93.75	93.75	93.75	46.88	93.75	46.88	100.00	100.00	100.00	53.08	53.13
2BB1632J 2.00 kVA	kVA	45.03	51.10	46.03	25.33	51.96	22.52	53.11	54.04	55.43	28.69	29.44
	Load Amps	125.00	125.00	125.00	62.50	125.00	62.50	133.33	133.33	133.33	70.78	70.83
3BB1632J 3.00 kVA	kVA	67.55	76.64	67.55	38.00	77.94	33.77	79.67	81.06	83.14	43.03	44.17
	Load Amps	187.50	187.50	187.50	93.75	187.50	93.75	200.00	200.00	200.00	106.17	106.25
5BB1632J 5.00 kVA	kVA	112.58	127.74	112.58	63.33	129.90	56.29	132.79	135.09	138.56	71.72	73.61
	Load Amps	312.50	312.50	312.50	156.25	312.50	156.25	333.33	333.33	333.33	176.95	177.08
Quantity Required		3	3	2	2	2	2	2	2	2	2	2
Connection Diagram (pg. 8-25)		5	5	11	12	11	12	11	11	11	12	12

* All Buck-Boost transformers listed are available for immediate shipment.

• Output voltage for lower input voltage can be found by:
 $\frac{\text{Rated Output Voltage}}{\text{Rated Input Voltage}} \times \text{Input Actual Voltage} = \text{Output New Voltage}$

• Output kVA available at reduced input voltage can be found by:
 $\frac{\text{Actual Input Voltage}}{\text{Rated Input Voltage}} \times \text{Output kVA} = \text{New kVA Rating}$

• Inputs and outputs may be reversed without affecting kVA capacity. See note on page 8-25.

Warehouse Stock Transformers

Buck-Boost

Selection

240 × 480 Volts Primary — 24/48 Volts Secondary, 60 Hz, No Taps, Wall Mounted

Single Phase — Table 5		Boosting										Bucking			
Catalog Number*	Line Voltage (Available)	230	380	416	425	430	435	440	450	450	460	277	480	480	504
Insulating Transformer Rating	Load Voltage (Output)	276	418	458	468	473	457	462	495	472	483	231	436	457	480
050BB2448J .050 kVA	kVA	.29	.44	.48	.49	.49	.95	.96	.52	.98	1.01	.29	.50	1.00	1.05
	Load Amps	1.04	1.04	1.04	1.04	1.04	2.08	2.08	1.04	2.08	2.08	1.25	1.15	2.19	2.19
100BB2448J .100 kVA	kVA	.58	.87	.95	.97	.99	1.90	1.93	1.03	1.97	2.01	.58	1.00	2.00	2.10
	Load Amps	2.08	2.08	2.08	2.08	2.08	4.17	4.17	2.08	4.17	4.17	2.50	2.29	4.38	4.38
150BB2448J .150 kVA	kVA	.86	1.31	1.43	1.46	1.48	2.86	2.89	1.55	2.95	3.02	.86	1.50	3.00	3.15
	Load Amps	3.13	3.13	3.13	3.13	3.13	6.25	6.25	3.13	6.25	6.25	3.75	3.44	6.56	6.56
205BB2448J .250 kVA	kVA	1.44	2.18	2.38	2.43	2.46	4.76	4.81	2.58	4.92	5.03	1.44	2.50	5.00	5.25
	Load Amps	5.21	5.21	5.21	5.21	5.21	10.42	10.42	5.21	10.42	10.42	6.25	5.73	10.94	10.94
505BB2448J .500 kVA	kVA	2.88	4.35	4.77	4.87	4.93	9.52	9.62	5.16	9.83	10.06	2.88	5.00	10.00	10.50
	Load Amps	10.42	10.42	10.42	10.42	10.42	20.83	20.83	10.42	20.83	20.83	12.50	11.46	21.88	21.88
705BB2448J .750 kVA	kVA	4.31	6.53	7.15	7.30	7.39	14.28	14.44	7.73	14.75	15.09	4.31	7.49	15.00	15.75
	Load Amps	15.63	15.63	15.62	15.63	15.63	31.25	31.25	15.63	31.25	31.25	18.75	17.19	32.81	32.81
1BB2448J 1.00 kVA	kVA	5.75	8.71	9.53	9.74	9.85	19.04	19.25	10.31	19.67	20.13	5.75	9.99	20.00	21.00
	Load Amps	20.83	20.83	20.83	20.83	20.83	41.67	41.67	20.83	41.67	41.67	25.00	22.92	43.75	43.75
105BB2448J 1.50 kVA	kVA	8.63	13.06	14.30	14.61	14.78	28.56	28.88	15.47	29.50	30.19	8.63	14.99	30.00	31.50
	Load Amps	31.25	31.25	31.25	31.25	31.25	62.50	62.50	31.25	62.50	62.50	37.50	34.38	65.63	65.63
2BB2448J 2.00 kVA	kVA	11.50	17.42	19.07	19.48	19.71	38.08	38.50	20.63	39.33	40.25	11.50	19.98	40.00	42.00
	Load Amps	41.67	41.67	41.67	41.67	41.67	83.33	83.33	41.67	83.33	83.33	50.00	45.83	87.50	87.50
3BB2448J 3.00 kVA	kVA	17.25	26.13	28.60	29.22	29.56	57.13	57.75	30.94	59.00	60.38	17.25	29.98	60.00	63.00
	Load Amps	62.50	62.50	62.50	62.50	62.50	125.00	125.00	62.50	125.00	125.00	75.00	68.80	131.25	131.25
5BB2448J 5.00 kVA	kVA	28.75	43.54	47.67	48.70	49.30	95.20	96.20	51.56	98.30	100.60	28.80	50.00	100.00	105.00
	Load Amps	104.17	104.17	104.17	104.17	104.20	208.30	208.30	104.17	208.30	208.30	125.00	114.60	218.75	218.75
Connection Diagram (pg. 8-25)		2	4	4	4	4	3	3	4	3	3	2	4	3	3

Three Phase — Table 6		Boosting								Bucking							
Catalog Number*	Line Voltage (Available)	399Y/ 230	380	430	440	460	460	480	480	440	440	460	460	480	480	500	500
Insulating Transformer Rating	Load Voltage (Output)	480Y/ 277	418	473	462	506	483	528	504	400	419	438	418	457	436	455	476
050BB2448J .050 kVA	kVA	.86	.75	.85	1.66	.91	1.74	.95	1.82	.79	1.58	1.66	.83	1.73	.86	.90	1.80
	Load Amps	1.04	1.04	1.04	2.08	1.04	2.08	1.04	2.08	1.14	2.18	2.18	1.14	2.18	1.14	1.14	2.19
100BB2448J .100 kVA	kVA	1.73	1.51	1.70	3.33	1.82	3.48	1.90	3.63	1.59	3.17	3.31	1.66	3.46	1.73	1.80	3.61
	Load Amps	2.08	2.08	2.08	4.16	2.08	4.16	2.08	4.16	2.29	4.37	4.37	2.29	4.37	2.29	2.29	4.38
150BB2448J .150 kVA	kVA	2.60	2.26	2.56	4.99	2.73	5.22	2.85	5.45	2.38	4.75	4.97	2.48	5.19	2.59	2.70	5.41
	Load Amps	3.12	3.13	3.12	6.24	3.12	6.25	3.12	6.24	3.43	6.55	6.55	3.43	6.55	3.43	3.43	6.56
205BB2448J .250 kVA	kVA	4.33	3.77	4.26	8.32	4.56	8.70	4.76	9.08	3.96	7.92	8.28	4.14	8.64	4.32	4.51	9.02
	Load Amps	5.20	5.21	5.20	10.40	5.20	10.40	5.20	10.40	5.72	10.92	10.92	5.72	10.92	5.72	5.72	10.94
505BB2448J .500 kVA	kVA	8.60	7.54	8.52	16.64	9.11	17.40	9.51	18.16	7.93	15.85	16.57	8.28	17.29	8.64	9.02	18.04
	Load Amps	10.40	10.42	10.40	20.80	10.40	20.80	10.40	20.80	11.44	21.84	21.84	11.44	21.84	11.44	11.44	21.88
705BB2448J .750 kVA	kVA	12.90	11.31	12.77	24.97	13.67	26.10	14.27	27.24	11.89	23.77	24.85	12.42	25.93	12.96	13.52	27.06
	Load Amps	15.60	15.63	15.60	31.20	15.60	31.20	15.60	31.20	17.16	32.76	32.76	17.16	32.76	17.16	17.16	32.81
1BB2448J 1.00 kVA	kVA	17.30	15.08	17.03	33.29	18.23	34.80	19.02	36.31	15.85	31.70	33.14	16.57	34.57	17.28	18.03	36.08
	Load Amps	20.80	20.83	20.80	41.60	20.80	41.60	20.80	41.60	22.88	43.68	43.68	22.88	43.68	22.88	22.88	43.75
105BB2448J 1.50 kVA	kVA	25.90	22.62	25.55	49.93	27.34	52.50	28.53	54.47	23.78	47.55	49.71	24.85	51.86	25.92	27.05	54.13
	Load Amps	31.20	31.25	31.20	62.40	31.20	62.40	31.20	62.40	34.32	65.52	65.52	34.32	65.62	34.32	34.32	65.63
2BB2448J 2.00 kVA	kVA	34.60	30.17	34.07	66.58	36.46	69.60	38.04	72.63	31.70	63.40	66.27	33.13	69.15	34.56	36.06	72.17
	Load Amps	41.60	41.67	41.60	83.20	41.60	83.20	41.60	83.20	45.76	87.36	87.36	45.76	87.36	45.76	45.76	87.50
3BB2448J 3.00 kVA	kVA	52.00	45.25	51.18	100.03	54.69	104.57	57.07	109.12	47.63	95.25	99.57	49.77	103.89	51.92	54.18	108.25
	Load Amps	62.50	62.50	62.50	125.00	62.50	125.00	62.50	125.00	68.75	131.25	131.25	68.75	131.25	68.75	68.75	131.25
5BB2448J 5.00 kVA	kVA	86.10	75.42	85.17	166.44	91.15	174.01	95.11	181.57	79.26	158.50	165.69	82.83	172.87	86.39	90.16	180.42
	Load Amps	104.00	104.17	104.00	208.00	104.00	208.00	104.00	208.00	114.40	218.40	218.40	114.40	218.40	114.40	114.40	218.75
Quantity Required		3	2	2	2	2	2	2	2	2	2	2	2	2	2	2	2
Connection Diagram (pg. 8-25)		6	12	12	11	12	11	12	11	12	11	12	11	12	12	12	11

* All Buck-Boost transformers listed are available for immediate shipment.

• Output voltage for lower input can be found by:
 $\frac{\text{Rated Output Voltage}}{\text{Rated Input Voltage}} \times \text{Input Actual Voltage} = \text{Output New Voltage.}$

• Output kVA available at reduced input voltage can be found by:
 $\frac{\text{Actual Input Voltage}}{\text{Rated Input Voltage}} \times \text{Output kVA} = \text{New kVA Rating.}$

• Inputs and outputs may be reversed without affecting kVA capacity. See note on page 8-25.

Buck-Boost Transformers

Single Phase, Three Phase

Typical Connection Diagrams

If you are using this unit as an **auto transformer** to buck (lower) or boost (raise) the voltage by a 12 to 48 volts use the information on pages 8-22 to 8-24 to select the proper wiring diagram.

Note: HV= Higher Voltage, LV= Lower Voltage when bucking and boosting.

If you are using this unit as an isolation transformer with a primary of 120 or 240 or 480 volts and the secondary of 12/24, 16/32, or 24/48 (depending on the model) use the wiring diagram located on the inside of the cover to the wiring compartment.

Low-voltage Applications:

By using the "Standard Step-down Application" diagram at left, buck boost transformers will convert 120V or 240V to 12, 24, 16 or 32 volts and 240V or 480V to 24 or 48 volts without affecting the nameplate kVA rating of the transformer. Buck boost transformers used in this type of application will become isolation or insulating type transformers.

(Standard Step-down Application)*

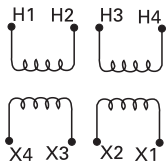

Single Phase

Diagram 1

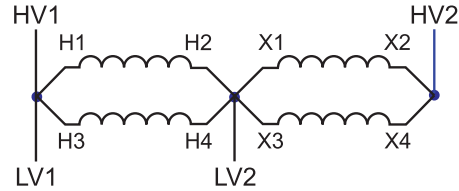

Diagram 2

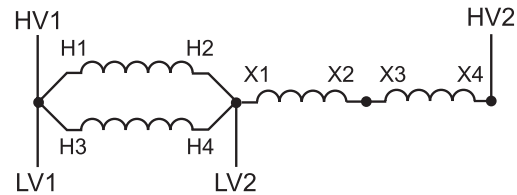

Diagram 3

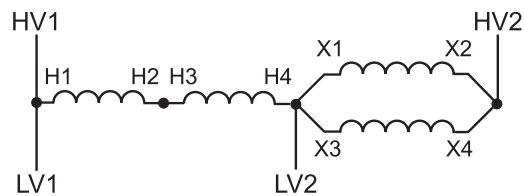
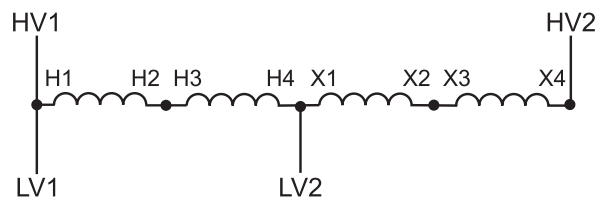

Diagram 4



Note:

- Inputs and Outputs may be reversed; kVA capacity remains constant. Exception: Cannot use 3-wire input with 4-wire output to form a neutral and does not apply to standard step-down applications.

- Refer to NEC 450-4 for overcurrent protection of an autotransformer.
- All applications are suitable for 60Hz only, contact factory for 50Hz information.

Buck-Boost Transformers

Single Phase, Three Phase

Typical Connection Diagrams

Three Phase

Note: Contact sales office for diagrams applicable to "J" suffix.

Diagram 5^①

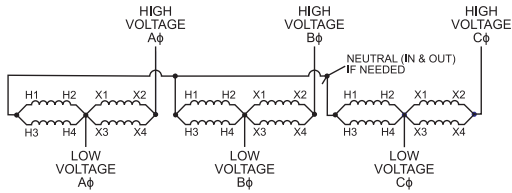

Diagram 6^①

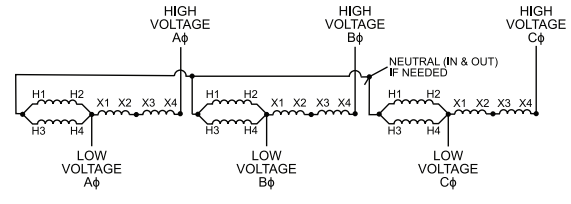

Diagram 7^①

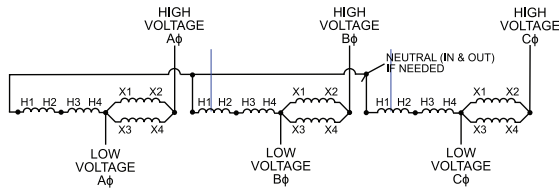

Diagram 8^①

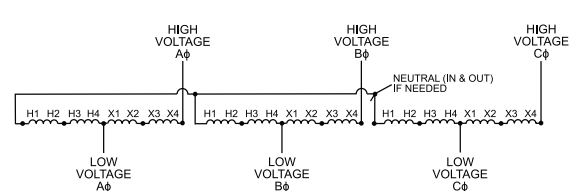

Diagram 9

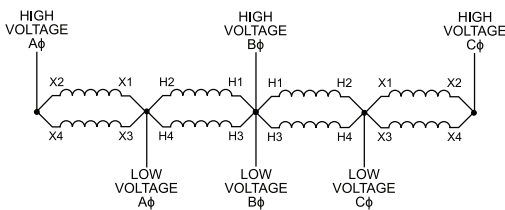

Diagram 11^②

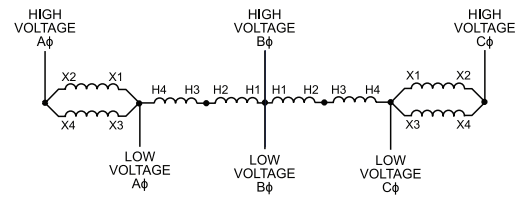
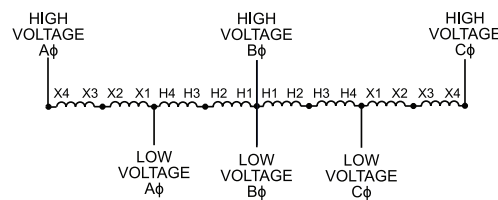

Diagram 12^②



① These diagrams can only be used when the source is a 4-wire supply.
 ② The neutral XO should not be used when the source is a three wire supply.

Note:
 • Inputs and Outputs may be reversed; kVA capacity remains constant. Exception: Cannot use 3-wire input with 4-wire output to form a neutral and does not apply to standard step-down applications.

• Refer to NEC 450-4 for overcurrent protection of an autotransformer.
 • All applications are suitable for 60Hz only, contact factory for 50Hz information.

Warehouse Stock Transformers

Drip Shield/Weather Shield Kits for Ventilated Transformers^②

Drip shields are integral to enclosure for Series H transformers and all DOE 2016 Series J transformers. Include DS option code to catalog number to include with single phase Series J transformers. Drip shield kits are available for field installation for Series J and other previously sold series transformers. Call factory for price and availability. See page 8-8 for additional information.

Wall Mounting Brackets for Ventilated Transformers

For Series H transformers, wall brackets are integral to the enclosure up to 30kVA and most 45kVA. A Wall Bracket Kit is available for 45kVA transformers that do not include wall brackets and for most 75kVA transformers. They should be ordered separately for field installation rather than including the W option in the catalog number. Series H wall brackets are not seismic certified. For Series J, include W option code for wall brackets to come with Series J transformers up to 75kVA or order separately for field installation. Call factory for price and availability.

Terminal Lug Kits For Ventilated Transformers^⑤

Catalog Number	Single Phase kVA Sizes	Three Phase kVA Sizes	Primary Terminal Lug Qty. ^④	Range	Secondary Terminal Lug Qty. ^④	Cable Range	Primary Hardware Included		Secondary Hardware Included	
							Qty.	Bolt Size	Qty.	Bolt Size
TLK14Q	75, 100	—	4	#6-350 kcmil	8	#6-350 kcmil	4	3/8 x 1 1/2	8	3/8 x 1 1/2
TLK15Q	167.5	—	8	#6-350 kcmil	12	1/0-750 kcmil	8	3/8 x 1 1/2	12	1/2 x 1 1/2
TLK34Q	—	112.5	3	#6-350 kcmil	8	#6-350 kcmil	3	3/8 x 1 1/2	8	3/8 x 1 1/2
TLK35Q	—	150	3	#6-350 kcmil	8	1/0-750 kcmil	3	3/8 x 1 1/2	8	3/8 x 1 1/2
TLK36Q	—	225	6	#6-350 kcmil	16	#6-350 kcmil	6	3/8 x 1 1/2	16	3/8 x 1 1/2
TLK37Q	—	300	6	#6-350 kcmil	16	1/0-750 kcmil	6	3/8 x 1 1/2	16	1/2 x 1 1/2
TLK38Q	—	500	9	#6-350 kcmil	24	1/0-750 kcmil	9	3/8 x 1 1/2	24	1/2 x 1 1/2
TLK39Q	—	750	12	#6-350 kcmil	28	1/0-750 kcmil	12	3/8 x 1 1/2	28	1/2 x 1 1/2

③ May be used on "JST" suffix and "non JST" suffix transformers. Terminal lugs are screw type, lug connectors suitable for both copper and aluminum cable. All lugs are single barrel and suitable for cable ranges shown. 750kcmil lugs are capable of holding (2) 250kcmil cables in lieu of (1) 750kcmil cable. All lugs are rated 90°C.
 ④ Lug kits contain quantity required for each kVA based NEC ampacities for cable range indicated. For cable sizes outside the range, hole size of terminal may not be the correct size to mount other lugs. Bolt size in Hardware included column provides indication of hole size.

⑤ Primary and secondary terminal lugs are included on most ventilated transformers. (15kVA - 75kVA 3PH & 15kVA - 50kVA 1PH). Some 45 or 75kVA may not have secondary lugs depending on number and type of additional options. Call factory for confirmation.

Standard Terminal Lug Offerings^⑦

(Primary and Secondary) for Ventilated Transformers (150 Degree Rise - Series J only - Without a K rating)									
1-Phase					3-Phase				
kVA	120/240V	208V	480V	600V	kVA	120/240V	208V	480V	600V
0-15	Contact customer support ^⑥				0-15	Contact customer support ^⑥			
15	#2/0-6	#14-2	#14-2	#14-2	15	#14-2	#14-2	#14-2	#14-2
25	250MCM-6	250MCM-6	#14-2	#14-2	30	#2/0-6	#2/0-6	#14-2	#14-2
37.5	350MCM-6	350MCM-6	#14-2	#14-2	45	250MCM-6	250MCM-6	#14-2	#14-2
50	600MCM-2	600MCM-2	#2/0-6	#2/0-6	75	600MCM-2	350MCM-6	#2/0-6	#2/0-6
>50	Contact customer support				>75	Contact customer support			

⑥ Values listed above are for standard configurations. There may be slight variations depending on requirements. Contact Customer Support for special requirements. Encapsulated units less than or equal to 15kVA do not have lugs. Lead wires are provided.
 ⑦ For Series H, see chart in Series H Addendum - Page H-17 Lug Pad sizes are not available except on cutsheets. Contact Customer Support for special requirements.

Wall Bracket Kits for Series J DOE 2016 3 Phase Transformers

Series J Wall Bracket Kits ^⑧							
kVA	Temp Rise			K Factor			
	150C	115C	80C	K1	K4	K13	K20
15	TWB15J	TWB15J	TWB75J	TWB15J	TWB15J	TWB75J	TWB75J
30	TWB75J	TWB75J	TWB75J	TWB75J	TWB75J	TWB75J	TWB75J
45	TWB75J	TWB75J	NA	TWB75J	TWB75J	NA	NA
75 ^⑨	TWB75J	TWB75J	NA	TWB75J	TWB75J	NA	NA

⑧ Wall Bracket Kit not available for 75kVA with Copper Windings.
 ⑨ See Wall Bracket/Drip Shield Table on Page 8-8 for availability information.

Wall Bracket for Series J Single Phase Transformers

Series J Wall Bracket Kits			
kVA	Temp Rise		
	150C	115C	80C
15	TWB15J	TWB15J	TWB75J
25	TWB75J	TWB75J	TWB75J
37.5	TWB75J	TWB75J	TWB75J
50	TWB75J	TWB75J	TWB75J
75	NA	NA	NA
100	NA	NA	NA

① Series J Drip Shield Kits are available as a special order. Add "XD" to the catalog number.

② UL Listed for indoor and outdoor use with dripshield installed.

Transformers

Notes

8

TRANSFORMERS

Series H Transformers

2016 DOE Compliant

Contents

Series H Data Charts – Copper and Aluminum	H-2 – H-9
K1, K4, K13 208V Delta 3-Phase Primary 208Y/120 Secondary Series H	H-2
K1, K4, K13 208V Delta 3-Phase Primary 480YY/277 Secondary Series H	H-3
K1, K4, K13 240V Delta 3-Phase Primary 208Y/120 Secondary Series H	H-4
K1, K4, K13 240V Delta 3-Phase Primary 480YY/277 Secondary Series H	H-5
K1, K4, K13 480V Delta 3-Phase Primary 240Delta/120CT Secondary Series H	H-6
K1, K4, K13 480V Delta 3-Phase Primary 208Y/120 Secondary Series H	H-7
K1, K4, K13 480V Delta 3-Phase Primary 480YY/277 Secondary Series H	H-8
K1, K4, K13 600V Delta 3-Phase Primary 208Y/120 Secondary Series H	H-9
K1, K4, K13 600V Delta 3-Phase Primary 480YY/277 Secondary Series H	H-10
Wiring Diagrams	H-11 – H-14
Enclosure Drawings	H-15 – H-16
Termination Details	H-17
Typical Performance Data	H-18 – H-25

DOE 2016 3-Phase Dry Type Ventilated Transformer

K1 208V Delta 3-Phase Primary Series H

Primary: 3-Phase Delta 208V Secondary: 208Y/120V K-Factor: K-1		Temperature Rise 150C [Blank]						Temperature Rise 115C [F]				Temperature Rise 80C [B]				Wiring Diagram	Mounting Type
Phase/ Voltage	Tap [x]	kVA [yyy]		Aluminum		Copper		Aluminum		Copper		Aluminum		Copper			
		kVA	yyy	Encl. Type	Weight	Encl. Type	Weight	Encl. Type	Weight	Encl. Type	Weight	Encl. Type	Weight	Encl. Type	Weight		
3B3	Y	15	015	DH1	210	DH1	210	TBD	TBD	TBD	TBD	TBD	TBD	TBD	TBD	SCD 19	F or W*/C*
3B3	Y	30	030	DH2	310	DH2	340	TBD	TBD	DH2	325	TBD	TBD	TBD	TBD	SCD 19	F or W*/C*
3B3	Y	45	045	DH2	380	DH2	400	TBD	TBD	DH2	435	TBD	TBD	TBD	TBD	SCD 19	F or W*/C*
3B3	Y	75	075	DH3	510	DH3	590	TBD	TBD	TBD	TBD	TBD	TBD	TBD	TBD	SCD 19	F (Opt W/C)
3B3	Y	112.5	112	DH3	680	DH3	740	TBD	TBD	TBD	TBD	TBD	TBD	TBD	TBD	SCD 19	F (Opt W/C)
3B3	Y	150	150	DH4	870	DH4	930	TBD	TBD	TBD	TBD	TBD	TBD	TBD	TBD	SCD 19	F
3B3	S	225	225	DH5	1350	DH4	1350	TBD	TBD	TBD	TBD	TBD	TBD	TBD	TBD	SCD 7A	F
3B3	S	300	300	DH5	1800	DH5	1800	TBD	TBD	DH5	2150	TBD	TBD	TBD	TBD	SCD 7A	F
3B3	S	500	500	DH6	2750	DH6	3200	TBD	TBD	TBD	TBD	TBD	TBD	TBD	TBD	SCD 8	F
3B3	N	750	750	DH7	4100	DH6	4050	TBD	TBD	TBD	TBD	TBD	TBD	TBD	TBD	SCD 60	F
3B3	N	1000	000	DH8	5400	DH7	5200	TBD	TBD	TBD	TBD	TBD	TBD	TBD	TBD	SCD 60	F

W*/C*: Built-in Wall/Ceiling Mounting **OSHPD Certified for Floor Mounting Only Opt W/C: Wall/Ceiling Mounting Kit "DW3" Available

Primary: 3-Phase Delta 208V Secondary: 208Y/120V K-Factor: K-4		Temperature Rise 150C [Blank]						Temperature Rise 115C [F]				Temperature Rise 80C [B]				Wiring Diagram	Mounting Type
Phase/ Voltage	Tap [x]	kVA [yyy]		Aluminum		Copper		Aluminum		Copper		Aluminum		Copper			
		kVA	yyy	Encl. Type	Weight	Encl. Type	Weight	Encl. Type	Weight	Encl. Type	Weight	Encl. Type	Weight	Encl. Type	Weight		
3B3	Y	15	015	DH1	TBD	DH1	TBD	TBD	TBD	TBD	TBD	TBD	TBD	DH1	255	SCD 19	F or W*/C*
3B3	Y	30	030	DH2	TBD	DH2	TBD	TBD	TBD	TBD	TBD	TBD	TBD	TBD	TBD	SCD 19	F or W*/C*
3B3	Y	45	045	DH2	TBD	DH2	TBD	TBD	TBD	TBD	TBD	TBD	TBD	TBD	TBD	SCD 19	F or W*/C*
3B3	Y	75	075	DH3	TBD	DH3	TBD	TBD	TBD	TBD	TBD	TBD	TBD	TBD	TBD	SCD 19	F (Opt W/C)
3B3	Y	112.5	112	DH3	TBD	DH3	TBD	TBD	TBD	TBD	TBD	TBD	TBD	TBD	TBD	SCD 19	F (Opt W/C)
3B3	Y	150	150	DH4	TBD	DH4	TBD	TBD	TBD	TBD	TBD	TBD	TBD	TBD	TBD	SCD 19	F
3B3	S	225	225	DH5	TBD	DH4	TBD	TBD	TBD	TBD	TBD	TBD	TBD	TBD	TBD	SCD 7A	F
3B3	S	300	300	DH5	TBD	DH5	TBD	TBD	TBD	TBD	TBD	TBD	TBD	TBD	TBD	SCD 7A	F
3B3	S	500	500	DH6	TBD	DH6	TBD	TBD	TBD	TBD	TBD	TBD	TBD	TBD	TBD	SCD 8	F
3B3	N	750	750	DH7	TBD	DH6	TBD	TBD	TBD	TBD	TBD	TBD	TBD	TBD	TBD	SCD 60	F
3B3	N	1000	000	DH8	TBD	DH7	TBD	TBD	TBD	TBD	TBD	TBD	TBD	TBD	TBD	SCD 60	F

W*/C*: Built-in Wall/Ceiling Mounting **OSHPD Certified for Floor Mounting Only Opt W/C: Wall/Ceiling Mounting Kit "DW3" Available

Primary: 3-Phase Delta 208V Secondary: 208Y/120V K-Factor: K-13		Temperature Rise 150C [Blank]						Temperature Rise 115C [F]				Temperature Rise 80C [B]				Wiring Diagram	Mounting Type
Phase/ Voltage	Tap [x]	kVA [yyy]		Aluminum		Copper		Aluminum		Copper		Aluminum		Copper			
		kVA	yyy	Encl. Type	Weight	Encl. Type	Weight	Encl. Type	Weight	Encl. Type	Weight	Encl. Type	Weight	Encl. Type	Weight		
3B3	Y	15	015	DH1	TBD	DH1	TBD	TBD	TBD	TBD	TBD	TBD	TBD	TBD	TBD	SCD 19	F or W*/C*
3B3	Y	30	030	DH2	TBD	DH2	TBD	TBD	TBD	TBD	TBD	TBD	TBD	TBD	TBD	SCD 19	F or W*/C*
3B3	Y	45	045	DH2	TBD	DH2	TBD	TBD	TBD	TBD	TBD	TBD	TBD	TBD	TBD	SCD 19	F or W*/C*
3B3	Y	75	075	DH3	TBD	DH3	TBD	TBD	TBD	TBD	TBD	TBD	TBD	TBD	TBD	SCD 19	F (Opt W/C)
3B3	Y	112.5	112	DH3	TBD	DH3	TBD	TBD	TBD	TBD	TBD	TBD	TBD	TBD	TBD	SCD 19	F (Opt W/C)
3B3	Y	150	150	DH4	TBD	DH4	TBD	TBD	TBD	TBD	TBD	TBD	TBD	TBD	TBD	SCD 19	F
3B3	S	225	225	DH5	TBD	DH4	TBD	TBD	TBD	TBD	TBD	TBD	TBD	TBD	TBD	SCD 7A	F
3B3	S	300	300	DH5	TBD	DH5	TBD	TBD	TBD	TBD	TBD	TBD	TBD	TBD	TBD	SCD 7A	F
3B3	S	500	500	DH6	TBD	DH6	TBD	TBD	TBD	TBD	TBD	TBD	TBD	TBD	TBD	SCD 8	F
3B3	N	750	750	DH7	TBD	DH6	TBD	TBD	TBD	TBD	TBD	TBD	TBD	TBD	TBD	SCD 60	F
3B3	N	1000	000	DH8	TBD	DH7	TBD	TBD	TBD	TBD	TBD	TBD	TBD	TBD	TBD	SCD 60	F

W*/C*: Built-in Wall/Ceiling Mounting **OSHPD Certified for Floor Mounting Only Opt W/C: Wall/Ceiling Mounting Kit "DW3" Available

DOE 2016 3-Phase Dry Type Ventilated Transformer

K1 208V Delta 3-Phase Primary Series H

Primary: 3-Phase Delta 208V Secondary: 480Y/277 K-Factor: K-1				Temperature Rise 150C [Blank]				Temperature Rise 115C [F]				Temperature Rise 80C [B]				Wiring Diagram	Mounting Type
Phase/Voltage	Tap [x]	kVA [yyy]		Aluminum		Copper		Aluminum		Copper		Aluminum		Copper			
		kVA	yyy	Encl. Type	Weight	Encl. Type	Weight	Encl. Type	Weight	Encl. Type	Weight	Encl. Type	Weight	Encl. Type	Weight		
3B5	Y	15	015	DH1	210	DH1	210	TBD	TBD	TBD	TBD	TBD	TBD	TBD	TBD	SCD 53	F or W*/C*
3B5	Y	30	030	DH2	310	DH2	340	TBD	TBD	TBD	TBD	TBD	TBD	TBD	TBD	SCD 53	F or W*/C*
3B5	Y	45	045	DH2	380	DH2	400	TBD	TBD	DH2	420	TBD	TBD	TBD	TBD	SCD 53	F or W*/C*
3B5	Y	75	075	DH3	510	DH3	590	TBD	TBD	TBD	TBD	TBD	TBD	TBD	TBD	SCD 53	F (Opt W/C)
3B5	Y	112.5	112	DH3	680	DH3	740	TBD	TBD	TBD	TBD	TBD	TBD	TBD	TBD	SCD 53	F (Opt W/C)
3B5	Y	150	150	DH4	870	DH4	930	TBD	TBD	TBD	TBD	TBD	TBD	TBD	TBD	SCD 53	F
3B5	S	225	225	DH5	1350	DH4	1350	TBD	TBD	DH4	1550	TBD	TBD	TBD	TBD	SCD 56	F
3B5	S	300	300	DH5	1800	DH5	1800	TBD	TBD	TBD	TBD	TBD	TBD	TBD	TBD	SCD 56	F
3B5	S	500	500	DH6	2750	DH6	3200	TBD	TBD	TBD	TBD	TBD	TBD	TBD	TBD	SCD 23A	F
3B5	N	750	750	DH7	4100	DH6	4050	TBD	TBD	TBD	TBD	TBD	TBD	TBD	TBD	SCD 61	F
3B5	N	1000	000	DH8	5400	DH7	5200	TBD	TBD	TBD	TBD	TBD	TBD	TBD	TBD	SCD 61	F

W*/C*: Built-in Wall/Ceiling Mounting **OSHPD Certified for Floor Mounting Only Opt W/C: Wall/Ceiling Mounting Kit "DW3"

Primary: 3-Phase Delta 208V Secondary: 480Y/277 K-Factor: K-4				Temperature Rise 150C [Blank]				Temperature Rise 115C [F]				Temperature Rise 80C [B]				Wiring Diagram	Mounting Type
Phase/Voltage	Tap [x]	kVA [yyy]		Aluminum		Copper		Aluminum		Copper		Aluminum		Copper			
		kVA	yyy	Encl. Type	Weight	Encl. Type	Weight	Encl. Type	Weight	Encl. Type	Weight	Encl. Type	Weight	Encl. Type	Weight		
3B5	Y	15	015	DH1	TBD	DH1	TBD	TBD	TBD	TBD	TBD	TBD	TBD	TBD	TBD	SCD 53	F or W*/C*
3B5	Y	30	030	DH2	TBD	DH2	TBD	TBD	TBD	TBD	TBD	TBD	TBD	TBD	TBD	SCD 53	F or W*/C*
3B5	Y	45	045	DH2	TBD	DH2	TBD	TBD	TBD	TBD	TBD	TBD	TBD	TBD	TBD	SCD 53	F or W*/C*
3B5	Y	75	075	DH3	TBD	DH3	TBD	TBD	TBD	TBD	TBD	TBD	TBD	TBD	TBD	SCD 53	F (Opt W/C)
3B5	Y	112.5	112	DH3	TBD	DH3	TBD	TBD	TBD	TBD	TBD	TBD	TBD	TBD	TBD	SCD 53	F (Opt W/C)
3B5	Y	150	150	DH4	TBD	DH4	TBD	TBD	TBD	TBD	TBD	TBD	TBD	TBD	TBD	SCD 53	F
3B5	S	225	225	DH5	TBD	DH4	TBD	TBD	TBD	TBD	TBD	TBD	TBD	TBD	TBD	SCD 56	F
3B5	S	300	300	DH5	TBD	DH5	TBD	TBD	TBD	TBD	TBD	TBD	TBD	TBD	TBD	SCD 56	F
3B5	S	500	500	DH6	TBD	DH6	TBD	TBD	TBD	TBD	TBD	TBD	TBD	TBD	TBD	SCD 23A	F
3B5	N	750	750	DH7	TBD	DH6	TBD	TBD	TBD	TBD	TBD	TBD	TBD	TBD	TBD	SCD 61	F
3B5	N	1000	000	DH8	TBD	DH7	TBD	TBD	TBD	TBD	TBD	TBD	TBD	TBD	TBD	SCD 61	F

W*/C*: Built-in Wall/Ceiling Mounting **OSHPD Certified for Floor Mounting Only Opt W/C: Wall/Ceiling Mounting Kit "DW3"

Primary: 3-Phase Delta 208V Secondary: 480Y/277 K-Factor: K-13				Temperature Rise 150C [Blank]				Temperature Rise 115C [F]				Temperature Rise 80C [B]				Wiring Diagram	Mounting Type
Phase/Voltage	Tap [x]	kVA [yyy]		Aluminum		Copper		Aluminum		Copper		Aluminum		Copper			
		kVA	yyy	Encl. Type	Weight	Encl. Type	Weight	Encl. Type	Weight	Encl. Type	Weight	Encl. Type	Weight	Encl. Type	Weight		
3B5	Y	15	015	DH1	TBD	DH1	TBD	TBD	TBD	TBD	TBD	TBD	TBD	TBD	TBD	SCD 53	F or W*/C*
3B5	Y	30	030	DH2	TBD	DH2	TBD	TBD	TBD	TBD	TBD	TBD	TBD	TBD	TBD	SCD 53	F or W*/C*
3B5	Y	45	045	DH2	TBD	DH2	TBD	TBD	TBD	TBD	TBD	TBD	TBD	TBD	TBD	SCD 53	F or W*/C*
3B5	Y	75	075	DH3	TBD	DH3	TBD	TBD	TBD	TBD	TBD	TBD	TBD	TBD	TBD	SCD 53	F (Opt W/C)
3B5	Y	112.5	112	DH3	TBD	DH3	TBD	TBD	TBD	TBD	TBD	TBD	TBD	TBD	TBD	SCD 53	F (Opt W/C)
3B5	Y	150	150	DH4	TBD	DH4	TBD	TBD	TBD	TBD	TBD	TBD	TBD	TBD	TBD	SCD 53	F
3B5	S	225	225	DH5	TBD	DH4	TBD	TBD	TBD	TBD	TBD	TBD	TBD	TBD	TBD	SCD 56	F
3B5	S	300	300	DH5	TBD	DH5	TBD	TBD	TBD	TBD	TBD	TBD	TBD	TBD	TBD	SCD 56	F
3B5	S	500	500	DH6	TBD	DH6	TBD	TBD	TBD	TBD	TBD	TBD	TBD	TBD	TBD	SCD 23A	F
3B5	N	750	750	DH7	TBD	DH6	TBD	TBD	TBD	TBD	TBD	TBD	TBD	TBD	TBD	SCD 61	F
3B5	N	1000	000	DH8	TBD	DH7	TBD	TBD	TBD	TBD	TBD	TBD	TBD	TBD	TBD	SCD 61	F

W*/C*: Built-in Wall/Ceiling Mounting **OSHPD Certified for Floor Mounting Only Opt W/C: Wall/Ceiling Mounting Kit "DW3"

Series H Addendum

DOE 2016 3-Phase Dry Type Ventilated Transformer

K1 240V Delta 3-Phase Primary Series H

Primary: 3-Phase Delta 240V Secondary: 208Y/120V K-Factor: K-1		Temperature Rise 150C [Blank]						Temperature Rise 115C [F]				Temperature Rise 80C [B]				Wiring Diagram	Mounting Type
Phase/ Voltage	Tap [x]	kVA [yyy]		Aluminum		Copper		Aluminum		Copper		Aluminum		Copper			
		kVA	yyy	Encl. Type	Weight	Encl. Type	Weight	Encl. Type	Weight	Encl. Type	Weight	Encl. Type	Weight	Encl. Type	Weight		
3C3	Y	15	015	DH1	210	DH1	210	TBD	TBD	TBD	TBD	TBD	TBD	TBD	TBD	SCD 19	F or W*/C*
3C3	Y	30	030	DH2	310	DH2	340	TBD	TBD	TBD	TBD	TBD	TBD	TBD	TBD	SCD 19	F or W*/C*
3C3	Y	45	045	DH2	380	DH2	400	TBD	TBD	TBD	TBD	TBD	TBD	TBD	TBD	SCD 19	F or W*/C*
3C3	Y	75	075	DH3	510	DH3	590	TBD	TBD	TBD	TBD	TBD	TBD	TBD	TBD	SCD 19	F (Opt W/C)
3C3	Y	112.5	112	DH3	680	DH3	740	TBD	TBD	TBD	TBD	TBD	TBD	TBD	TBD	SCD 19	F (Opt W/C)
3C3	Y	150	150	DH4	870	DH4	930	TBD	TBD	TBD	TBD	TBD	TBD	TBD	TBD	SCD 19	F
3C3	S	225	225	DH5	1350	DH4	1350	TBD	TBD	TBD	TBD	TBD	TBD	TBD	TBD	SCD 7A	F
3C3	S	300	300	DH5	1800	DH5	1800	TBD	TBD	TBD	TBD	TBD	TBD	TBD	TBD	SCD 7A	F
3C3	S	500	500	DH6	2750	DH6	3200	TBD	TBD	TBD	TBD	TBD	TBD	TBD	TBD	SCD 8	F
3C3	N	750	750	DH7	4100	DH6	4050	TBD	TBD	TBD	TBD	TBD	TBD	TBD	TBD	SCD 60	F
3C3	N	1000	000	DH8	5400	DH7	5200	TBD	TBD	TBD	TBD	TBD	TBD	TBD	TBD	SCD 60	F

W*/C*: Built-in Wall/Ceiling Mounting **OSHPD Certified for Floor Mounting Only Opt W/C: Wall/Ceiling Mounting Kit "DW3"

Primary: 3-Phase Delta 240V Secondary: 208Y/120V K-Factor: K-4		Temperature Rise 150C [Blank]						Temperature Rise 115C [F]				Temperature Rise 80C [B]				Wiring Diagram	Mounting Type
Phase/ Voltage	Tap [x]	kVA [yyy]		Aluminum		Copper		Aluminum		Copper		Aluminum		Copper			
		kVA	yyy	Encl. Type	Weight	Encl. Type	Weight	Encl. Type	Weight	Encl. Type	Weight	Encl. Type	Weight	Encl. Type	Weight		
3C3	Y	15	015	DH1	TBD	DH1	TBD	TBD	TBD	TBD	TBD	TBD	TBD	TBD	TBD	SCD 19	F or W*/C*
3C3	Y	30	030	DH2	TBD	DH2	TBD	TBD	TBD	TBD	TBD	TBD	TBD	TBD	TBD	SCD 19	F or W*/C*
3C3	Y	45	045	DH2	TBD	DH2	TBD	TBD	TBD	TBD	TBD	TBD	TBD	TBD	TBD	SCD 19	F or W*/C*
3C3	Y	75	075	DH3	TBD	DH3	TBD	TBD	TBD	TBD	TBD	TBD	TBD	TBD	TBD	SCD 19	F (Opt W/C)
3C3	Y	112.5	112	DH3	TBD	DH3	TBD	TBD	TBD	TBD	TBD	TBD	TBD	TBD	TBD	SCD 19	F (Opt W/C)
3C3	Y	150	150	DH4	TBD	DH4	TBD	TBD	TBD	TBD	TBD	TBD	TBD	TBD	TBD	SCD 19	F
3C3	S	225	225	DH5	TBD	DH4	TBD	TBD	TBD	TBD	TBD	TBD	TBD	TBD	TBD	SCD 7A	F
3C3	S	300	300	DH5	TBD	DH5	TBD	TBD	TBD	TBD	TBD	TBD	TBD	TBD	TBD	SCD 7A	F
3C3	S	500	500	DH6	TBD	DH6	TBD	TBD	TBD	TBD	TBD	TBD	TBD	TBD	TBD	SCD 8	F
3C3	N	750	750	DH7	TBD	DH6	TBD	TBD	TBD	TBD	TBD	TBD	TBD	TBD	TBD	SCD 60	F
3C3	N	1000	000	DH8	TBD	DH7	TBD	TBD	TBD	TBD	TBD	TBD	TBD	TBD	TBD	SCD 60	F

W*/C*: Built-in Wall/Ceiling Mounting **OSHPD Certified for Floor Mounting Only Opt W/C: Wall/Ceiling Mounting Kit "DW3"

Primary: 3-Phase Delta 240V Secondary: 208Y/120V K-Factor: K-13		Temperature Rise 150C [Blank]						Temperature Rise 115C [F]				Temperature Rise 80C [B]				Wiring Diagram	Mounting Type
Phase/ Voltage	Tap [x]	kVA [yyy]		Aluminum		Copper		Aluminum		Copper		Aluminum		Copper			
		kVA	yyy	Encl. Type	Weight	Encl. Type	Weight	Encl. Type	Weight	Encl. Type	Weight	Encl. Type	Weight	Encl. Type	Weight		
3C3	Y	15	015	DH1	TBD	DH1	TBD	TBD	TBD	TBD	TBD	TBD	TBD	TBD	TBD	SCD 19	F or W*/C*
3C3	Y	30	030	DH2	TBD	DH2	TBD	TBD	TBD	TBD	TBD	TBD	TBD	TBD	TBD	SCD 19	F or W*/C*
3C3	Y	45	045	DH2	TBD	DH2	TBD	TBD	TBD	TBD	TBD	TBD	TBD	TBD	TBD	SCD 19	F or W*/C*
3C3	Y	75	075	DH3	TBD	DH3	TBD	TBD	TBD	TBD	TBD	TBD	TBD	TBD	TBD	SCD 19	F (Opt W/C)
3C3	Y	112.5	112	DH3	TBD	DH3	TBD	TBD	TBD	TBD	TBD	TBD	TBD	TBD	TBD	SCD 19	F (Opt W/C)
3C3	Y	150	150	DH4	TBD	DH4	TBD	TBD	TBD	TBD	TBD	TBD	TBD	TBD	TBD	SCD 19	F
3C3	S	225	225	DH5	TBD	DH4	TBD	TBD	TBD	TBD	TBD	TBD	TBD	TBD	TBD	SCD 7A	F
3C3	S	300	300	DH5	TBD	DH5	TBD	TBD	TBD	TBD	TBD	TBD	TBD	TBD	TBD	SCD 7A	F
3C3	S	500	500	DH6	TBD	DH6	TBD	TBD	TBD	TBD	TBD	TBD	TBD	TBD	TBD	SCD 8	F
3C3	N	750	750	DH7	TBD	DH6	TBD	TBD	TBD	TBD	TBD	TBD	TBD	TBD	TBD	SCD 60	F
3C3	N	1000	000	DH8	TBD	DH7	TBD	TBD	TBD	TBD	TBD	TBD	TBD	TBD	TBD	SCD 60	F

W*/C*: Built-in Wall/Ceiling Mounting **OSHPD Certified for Floor Mounting Only Opt W/C: Wall/Ceiling Mounting Kit "DW3"

DOE 2016 3-Phase Dry Type Ventilated Transformer

K1 240V Delta 3-Phase Primary Series H

Primary: 3-Phase Delta 240V Secondary: 480Y/277V K-Factor: K-1				Temperature Rise 150C [Blank]				Temperature Rise 115C [F]				Temperature Rise 80C [B]				Wiring Diagram	Mounting Type
Phase/Voltage	Tap [x]	kVA [yyy]		Aluminum		Copper		Aluminum		Copper		Aluminum		Copper			
		kVA	yyy	Encl. Type	Weight	Encl. Type	Weight	Encl. Type	Weight	Encl. Type	Weight	Encl. Type	Weight	Encl. Type	Weight		
3C5	Y	15	015	DH1	210	DH1	210	TBD	TBD	TBD	TBD	TBD	TBD	TBD	TBD	SCD 53	F or W*/C*
3C5	Y	30	030	DH2	310	DH2	340	TBD	TBD	TBD	TBD	TBD	TBD	TBD	TBD	SCD 53	F or W*/C*
3C5	Y	45	045	DH2	380	DH2	400	TBD	TBD	TBD	TBD	TBD	TBD	TBD	TBD	SCD 53	F or W*/C*
3C5	Y	75	075	DH3	510	DH3	590	TBD	TBD	TBD	TBD	TBD	TBD	TBD	TBD	SCD 53	F (Opt W/C)
3C5	Y	112.5	112	DH3	680	DH3	740	TBD	TBD	TBD	TBD	TBD	TBD	TBD	TBD	SCD 53	F (Opt W/C)
3C5	Y	150	150	DH4	870	DH4	930	TBD	TBD	TBD	TBD	TBD	TBD	TBD	TBD	SCD 53	F
3C5	S	225	225	DH5	1350	DH4	1350	TBD	TBD	TBD	TBD	TBD	TBD	TBD	TBD	SCD 56	F
3C5	S	300	300	DH5	1800	DH5	1800	TBD	TBD	TBD	TBD	TBD	TBD	TBD	TBD	SCD 56	F
3C5	S	500	500	DH6	2750	DH6	3200	TBD	TBD	TBD	TBD	TBD	TBD	TBD	TBD	SCD 23A	F
3C5	N	750	750	DH7	4100	DH6	4050	TBD	TBD	TBD	TBD	TBD	TBD	TBD	TBD	SCD 61	F
3C5	N	1000	000	DH8	5400	DH7	5200	TBD	TBD	TBD	TBD	TBD	TBD	TBD	TBD	SCD 61	F

W*/C*: Built-in Wall/Ceiling Mounting **OSHPD Certified for Floor Mounting Only Opt W/C: Wall/Ceiling Mounting Kit "DW3"

Primary: 3-Phase Delta 240V Secondary: 480Y/277V K-Factor: K-4				Temperature Rise 150C [Blank]				Temperature Rise 115C [F]				Temperature Rise 80C [B]				Wiring Diagram	Mounting Type
Phase/Voltage	Tap [x]	kVA [yyy]		Aluminum		Copper		Aluminum		Copper		Aluminum		Copper			
		kVA	yyy	Encl. Type	Weight	Encl. Type	Weight	Encl. Type	Weight	Encl. Type	Weight	Encl. Type	Weight	Encl. Type	Weight		
3C5	Y	15	015	DH1	TBD	DH1	TBD	TBD	TBD	TBD	TBD	TBD	TBD	TBD	TBD	SCD 53	F or W*/C*
3C5	Y	30	030	DH2	TBD	DH2	TBD	TBD	TBD	TBD	TBD	TBD	TBD	TBD	TBD	SCD 53	F or W*/C*
3C5	Y	45	045	DH2	TBD	DH2	TBD	TBD	TBD	TBD	TBD	TBD	TBD	TBD	TBD	SCD 53	F or W*/C*
3C5	Y	75	075	DH3	TBD	DH3	TBD	TBD	TBD	TBD	TBD	TBD	TBD	TBD	TBD	SCD 53	F (Opt W/C)
3C5	Y	112.5	112	DH3	TBD	DH3	TBD	TBD	TBD	TBD	TBD	TBD	TBD	TBD	TBD	SCD 53	F (Opt W/C)
3C5	Y	150	150	DH4	TBD	DH4	TBD	TBD	TBD	TBD	TBD	TBD	TBD	TBD	TBD	SCD 53	F
3C5	S	225	225	DH5	TBD	DH4	TBD	TBD	TBD	TBD	TBD	TBD	TBD	TBD	TBD	SCD 56	F
3C5	S	300	300	DH5	TBD	DH5	TBD	TBD	TBD	TBD	TBD	TBD	TBD	TBD	TBD	SCD 56	F
3C5	S	500	500	DH6	TBD	DH6	TBD	TBD	TBD	TBD	TBD	TBD	TBD	TBD	TBD	SCD 23A	F
3C5	N	750	750	DH7	TBD	DH6	TBD	TBD	TBD	TBD	TBD	TBD	TBD	TBD	TBD	SCD 61	F
3C5	N	1000	000	DH8	TBD	DH7	TBD	TBD	TBD	TBD	TBD	TBD	TBD	TBD	TBD	SCD 61	F

W*/C*: Built-in Wall/Ceiling Mounting **OSHPD Certified for Floor Mounting Only Opt W/C: Wall/Ceiling Mounting Kit "DW3"

Primary: 3-Phase Delta 240V Secondary: 480Y/277V K-Factor: K-13				Temperature Rise 150C [Blank]				Temperature Rise 115C [F]				Temperature Rise 80C [B]				Wiring Diagram	Mounting Type
Phase/Voltage	Tap [x]	kVA [yyy]		Aluminum		Copper		Aluminum		Copper		Aluminum		Copper			
		kVA	yyy	Encl. Type	Weight	Encl. Type	Weight	Encl. Type	Weight	Encl. Type	Weight	Encl. Type	Weight	Encl. Type	Weight		
3C5	Y	15	015	DH1	TBD	DH1	TBD	TBD	TBD	TBD	TBD	TBD	TBD	TBD	TBD	SCD 53	F or W*/C*
3C5	Y	30	030	DH2	TBD	DH2	TBD	TBD	TBD	TBD	TBD	TBD	TBD	TBD	TBD	SCD 53	F or W*/C*
3C5	Y	45	045	DH2	TBD	DH2	TBD	TBD	TBD	TBD	TBD	TBD	TBD	TBD	TBD	SCD 53	F or W*/C*
3C5	Y	75	075	DH3	TBD	DH3	TBD	TBD	TBD	TBD	TBD	TBD	TBD	TBD	TBD	SCD 53	F (Opt W/C)
3C5	Y	112.5	112	DH3	TBD	DH3	TBD	TBD	TBD	TBD	TBD	TBD	TBD	TBD	TBD	SCD 53	F (Opt W/C)
3C5	Y	150	150	DH4	TBD	DH4	TBD	TBD	TBD	TBD	TBD	TBD	TBD	TBD	TBD	SCD 53	F
3C5	S	225	225	DH5	TBD	DH4	TBD	TBD	TBD	TBD	TBD	TBD	TBD	TBD	TBD	SCD 56	F
3C5	S	300	300	DH5	TBD	DH5	TBD	TBD	TBD	TBD	TBD	TBD	TBD	TBD	TBD	SCD 56	F
3C5	S	500	500	DH6	TBD	DH6	TBD	TBD	TBD	TBD	TBD	TBD	TBD	TBD	TBD	SCD 23A	F
3C5	N	750	750	DH7	TBD	DH6	TBD	TBD	TBD	TBD	TBD	TBD	TBD	TBD	TBD	SCD 61	F
3C5	N	1000	000	DH8	TBD	DH7	TBD	TBD	TBD	TBD	TBD	TBD	TBD	TBD	TBD	SCD 61	F

W*/C*: Built-in Wall/Ceiling Mounting **OSHPD Certified for Floor Mounting Only Opt W/C: Wall/Ceiling Mounting Kit "DW3"

Series H Addendum

DOE 2016 3-Phase Dry Type Ventilated Transformer

K1 480V Delta 3-Phase Primary Series H

Primary: 3-Phase Delta 480V Secondary: 240Delta/120CT K-Factor: K-1				Temperature Rise 150C [Blank]				Temperature Rise 115C [F]				Temperature Rise 80C [B]				Wiring Diagram	Mounting Type
Phase/ Voltage	Tap [x]	kVA [yyy]		Aluminum		Copper		Aluminum		Copper		Aluminum		Copper			
		kVA	yyy	Encl. Type	Weight	Encl. Type	Weight	Encl. Type	Weight	Encl. Type	Weight	Encl. Type	Weight	Encl. Type	Weight		
3F1	Y	15	015	DH1	210	DH1	210	TBD	TBD	TBD	TBD	TBD	TBD	TBD	TBD	SCD 21	F or W*/C*
3F1	Y	30	030	DH2	310	DH2	340	TBD	TBD	TBD	TBD	TBD	TBD	TBD	TBD	SCD 21	F or W*/C*
3F1	Y	45	045	DH2	380	DH2	400	TBD	TBD	TBD	TBD	TBD	TBD	TBD	TBD	SCD 21	F or W*/C*
3F1	Y	75	075	DH3	510	DH3	590	TBD	TBD	DH3	730	TBD	TBD	TBD	TBD	SCD 21	F (Opt W/C)
3F1	Y	112.5	112	DH3	680	DH3	740	TBD	TBD	TBD	TBD	TBD	TBD	TBD	TBD	SCD 21	F (Opt W/C)
3F1	Y	150	150	DH4	870	DH4	930	TBD	TBD	TBD	TBD	TBD	TBD	TBD	TBD	SCD 21	F
3F1	Y	225	225	DH5	1350	DH4	1350	TBD	TBD	DH4	1500	TBD	TBD	TBD	TBD	SCD 21	F
3F1	Y	300	300	DH5	1800	DH5	1800	TBD	TBD	TBD	TBD	TBD	TBD	TBD	TBD	SCD 21	F
3F1	Y	500	500	DH6	2750	DH6	3200	TBD	TBD	TBD	TBD	TBD	TBD	TBD	TBD	SCD 22	F
3F1	Y	750	750	DH7	4100	DH6	4050	TBD	TBD	TBD	TBD	TBD	TBD	TBD	TBD	SCD 22	F
3F1	T	1000	000	DH8	5400	DH7	5200	TBD	TBD	TBD	TBD	TBD	TBD	TBD	TBD	SCD 59	F

W*/C*: Built-in Wall/Ceiling Mounting **OSHPD Certified for Floor Mounting Only Opt W/C: Wall/Ceiling Mounting Kit "DW3"

Primary: 3-Phase Delta 480V Secondary: 240Delta/120CT K-Factor: K-4				Temperature Rise 150C [Blank]				Temperature Rise 115C [F]				Temperature Rise 80C [B]				Wiring Diagram	Mounting Type
Phase/ Voltage	Tap [x]	kVA [yyy]		Aluminum		Copper		Aluminum		Copper		Aluminum		Copper			
		kVA	yyy	Encl. Type	Weight	Encl. Type	Weight	Encl. Type	Weight	Encl. Type	Weight	Encl. Type	Weight	Encl. Type	Weight		
3F1	Y	15	015	DH1	TBD	DH1	TBD	TBD	TBD	TBD	TBD	TBD	TBD	TBD	TBD	SCD 21	F or W*/C*
3F1	Y	30	030	DH2	TBD	DH2	TBD	TBD	TBD	TBD	TBD	TBD	TBD	TBD	TBD	SCD 21	F or W*/C*
3F1	Y	45	045	DH2	TBD	DH2	TBD	TBD	TBD	TBD	TBD	TBD	TBD	TBD	TBD	SCD 21	F or W*/C*
3F1	Y	75	075	DH3	TBD	DH3	TBD	TBD	TBD	TBD	TBD	TBD	TBD	TBD	TBD	SCD 21	F (Opt W/C)
3F1	Y	112.5	112	DH3	TBD	DH3	TBD	TBD	TBD	TBD	TBD	TBD	TBD	TBD	TBD	SCD 21	F (Opt W/C)
3F1	Y	150	150	DH4	TBD	DH4	TBD	TBD	TBD	TBD	TBD	TBD	TBD	TBD	TBD	SCD 21	F
3F1	Y	225	225	DH5	TBD	DH4	TBD	TBD	TBD	TBD	TBD	TBD	TBD	TBD	TBD	SCD 21	F
3F1	Y	300	300	DH5	TBD	DH5	TBD	TBD	TBD	TBD	TBD	TBD	TBD	TBD	TBD	SCD 21	F
3F1	Y	500	500	DH6	TBD	DH6	TBD	TBD	TBD	TBD	TBD	TBD	TBD	TBD	TBD	SCD 22	F
3F1	Y	750	750	DH7	TBD	DH6	TBD	TBD	TBD	TBD	TBD	TBD	TBD	TBD	TBD	SCD 22	F
3F1	T	1000	000	DH8	TBD	DH7	TBD	TBD	TBD	TBD	TBD	TBD	TBD	TBD	TBD	SCD 59	F

W*/C*: Built-in Wall/Ceiling Mounting **OSHPD Certified for Floor Mounting Only Opt W/C: Wall/Ceiling Mounting Kit "DW3"

Primary: 3-Phase Delta 480V Secondary: 240Delta/120CT K-Factor: K-13				Temperature Rise 150C [Blank]				Temperature Rise 115C [F]				Temperature Rise 80C [B]				Wiring Diagram	Mounting Type
Phase/ Voltage	Tap [x]	kVA [yyy]		Aluminum		Copper		Aluminum		Copper		Aluminum		Copper			
		kVA	yyy	Encl. Type	Weight	Encl. Type	Weight	Encl. Type	Weight	Encl. Type	Weight	Encl. Type	Weight	Encl. Type	Weight		
3F1	Y	15	015	DH1	TBD	DH1	TBD	TBD	TBD	TBD	TBD	TBD	TBD	TBD	TBD	SCD 21	F or W*/C*
3F1	Y	30	030	DH2	TBD	DH2	TBD	TBD	TBD	TBD	TBD	TBD	TBD	TBD	TBD	SCD 21	F or W*/C*
3F1	Y	45	045	DH2	TBD	DH2	TBD	TBD	TBD	DH2	450	TBD	TBD	TBD	TBD	SCD 21	F or W*/C*
3F1	Y	75	075	DH3	TBD	DH3	TBD	TBD	TBD	TBD	TBD	TBD	TBD	TBD	TBD	SCD 21	F (Opt W/C)
3F1	Y	112.5	112	DH3	TBD	DH3	TBD	TBD	TBD	TBD	TBD	TBD	TBD	TBD	TBD	SCD 21	F (Opt W/C)
3F1	Y	150	150	DH4	TBD	DH4	TBD	TBD	TBD	TBD	TBD	TBD	TBD	TBD	TBD	SCD 21	F
3F1	Y	225	225	DH5	TBD	DH4	TBD	TBD	TBD	TBD	TBD	TBD	TBD	TBD	TBD	SCD 21	F
3F1	Y	300	300	DH5	TBD	DH5	TBD	TBD	TBD	TBD	TBD	TBD	TBD	TBD	TBD	SCD 21	F
3F1	Y	500	500	DH6	TBD	DH6	TBD	TBD	TBD	TBD	TBD	TBD	TBD	TBD	TBD	SCD 22	F
3F1	Y	750	750	DH7	TBD	DH6	TBD	TBD	TBD	TBD	TBD	TBD	TBD	TBD	TBD	SCD 22	F
3F1	T	1000	000	DH8	TBD	DH7	TBD	TBD	TBD	TBD	TBD	TBD	TBD	TBD	TBD	SCD 59	F

W*/C*: Built-in Wall/Ceiling Mounting **OSHPD Certified for Floor Mounting Only Opt W/C: Wall/Ceiling Mounting Kit "DW3"

DOE 2016 3-Phase Dry Type Ventilated Transformer

K1 480V Delta 3-Phase Primary Series H

Primary: 3-Phase Delta 480V Secondary: 208Y/120V K-Factor: K-1		Temperature Rise 150C [Blank]						Temperature Rise 115C [F]				Temperature Rise 80C [B]				Wiring Diagram	Mounting Type
Phase/Voltage	Tap [x]	kVA [yyy]		Aluminum		Copper		Aluminum		Copper		Aluminum		Copper			
		kVA	yyy	Encl. Type	Weight	Encl. Type	Weight	Encl. Type	Weight	Encl. Type	Weight	Encl. Type	Weight	Encl. Type	Weight		
3F3	Y	15	015	DH1	210	DH1	210	DH2	335	DH1	215	DH2	335	DH1	230	SCD 19	F or W*/C*
3F3	Y	30	030	DH2	310	DH2	340	DH2	380	DH2	410	DH2	380	DH2	410	SCD 19	F or W*/C*
3F3	Y	45	045	DH2	380	DH2	400	DH3	550	DH3	615	DH3	550	DH3	615	SCD 19	F or W*/C*
3F3	Y	75	075	DH3	510	DH3	590	DH3	685	DH3	775	DH3	685	DH3	775	SCD 19	F (Opt W/C)
3F3	Y	112.5	112	DH3	680	DH3	740	DH4	915	DH3	1000	DH4	TBD	DH3	1050	SCD 19	F (Opt W/C)
3F3	Y	150	150	DH4	870	DH4	930	DH5	1450	DH5	1400	DH5	1450	DH4	1350	SCD 19	F
3F3	Y	225	225	DH5	1350	DH4	1350	DH5	1900	DH5	1800	DH5	1900	DH5	2050	SCD 19	F
3F3	Y	300	300	DH5	1800	DH5	1800	DH5	TBD	DH5	2050	DH6	TBD	DH6	2650	SCD 19	F
3F3	Y	500	500	DH6	2750	DH6	3200	DH7	4100	DH6	3050	DH7	3400	DH6	3800	SCD 20	F
3F3	Y	750	750	DH7	4100	DH6	4050	DH8	TBD	DH6	TBD	TBD	TBD	DH8	TBD	SCD 20	F
3F3	T	1000	000	DH8	5400	DH7	5200	TBD	TBD	TBD	TBD	TBD	TBD	TBD	TBD	SCD 10	F

W*/C*: Built-in Wall/Ceiling Mounting **OSHPD Certified for Floor Mounting Only Opt W/C: Wall/Ceiling Mounting Kit "DW3"

Primary: 3-Phase Delta 480V Secondary: 208Y/120V K-Factor: K-4		Temperature Rise 150C [Blank]						Temperature Rise 115C [F]				Temperature Rise 80C [B]				Wiring Diagram	Mounting Type
Phase/Voltage	Tap [x]	kVA [yyy]		Aluminum		Copper		Aluminum		Copper		Aluminum		Copper			
		kVA	yyy	Encl. Type	Weight	Encl. Type	Weight	Encl. Type	Weight	Encl. Type	Weight	Encl. Type	Weight	Encl. Type	Weight		
3F3	Y	15	015	DH1	220	DH1	220	DH2	335	DH1	235	TBD	TBD	DH1	230	SCD 19	F or W*/C*
3F3	Y	30	030	DH2	320	DH2	350	TBD	TBD	DH2	TBD	TBD	TBD	DH2	TBD	SCD 19	F or W*/C*
3F3	Y	45	045	DH2	390	DH2	410	DH3	550	DH3	615	TBD	TBD	DH2	490	SCD 19	F or W*/C*
3F3	Y	75	075	DH3	530	DH3	600	DH3	685	DH3	TBD	TBD	TBD	DH3	740	SCD 19	F (Opt W/C)
3F3	Y	112.5	112	DH3	690	DH3	760	TBD	TBD	DH4	TBD	TBD	TBD	DH4	990	SCD 19	F (Opt W/C)
3F3	Y	150	150	DH4	900	DH4	950	DH5	1450	DH4	TBD	TBD	TBD	DH4	1200	SCD 19	F
3F3	Y	225	225	DH5	1380	DH4	1380	DH5	1900	DH5	1800	TBD	TBD	DH5	2050	SCD 19	F
3F3	Y	300	300	DH5	1830	DH5	1830	TBD	TBD	DH5	TBD	TBD	TBD	DH5	2150	SCD 19	F
3F3	Y	500	500	DH6	2800	DH6	3250	TBD	TBD	TBD	TBD	TBD	TBD	TBD	TBD	SCD 20	F
3F3	Y	750	750	DH7	4200	DH6	4100	TBD	TBD	TBD	TBD	TBD	TBD	TBD	TBD	SCD 20	F
3F3	T	1000	000	DH8	5500	DH7	5300	TBD	TBD	TBD	TBD	TBD	TBD	TBD	TBD	SCD 10	F

W*/C*: Built-in Wall/Ceiling Mounting **OSHPD Certified for Floor Mounting Only Opt W/C: Wall/Ceiling Mounting Kit "DW3"

Primary: 3-Phase Delta 480V Secondary: 208Y/120V K-Factor: K-13		Temperature Rise 150C [Blank]						Temperature Rise 115C [F]				Temperature Rise 80C [B]				Wiring Diagram	Mounting Type
Phase/Voltage	Tap [x]	kVA [yyy]		Aluminum		Copper		Aluminum		Copper		Aluminum		Copper			
		kVA	yyy	Encl. Type	Weight	Encl. Type	Weight	Encl. Type	Weight	Encl. Type	Weight	Encl. Type	Weight	Encl. Type	Weight		
3F3	Y	15	015	DH1	240	DH1	240	DH2	335	DH1	220	DH2	335	DH2	TBD	SCD 19	F or W*/C*
3F3	Y	30	030	DH2	340	DH2	370	TBD	TBD	DH2	TBD	TBD	TBD	DH2	TBD	SCD 19	F or W*/C*
3F3	Y	45	045	DH2	420	DH2	430	TBD	TBD	DH3	615	TBD	TBD	DH3	565	SCD 19	F or W*/C*
3F3	Y	75	075	DH3	560	DH3	620	DH3	685	DH3	775	TBD	TBD	DH3	TBD	SCD 19	F (Opt W/C)
3F3	Y	112.5	112	DH3	730	DH3	840	DH4	915	DH4	1000	TBD	TBD	DH4	1100	SCD 19	F (Opt W/C)
3F3	Y	150	150	DH4	1070	DH4	1100	DH5	1450	DH4	1250	TBD	TBD	DH4	1550	SCD 19	F
3F3	Y	225	225	DH5	1500	DH4	1620	DH5	1900	DH5	2000	TBD	TBD	DH5	TBD	SCD 19	F
3F3	Y	300	300	DH5	1950	DH5	2060	TBD	TBD	DH5	1950	TBD	TBD	DH6	2800	SCD 19	F
3F3	Y	500	500	DH6	2900	DH6	3400	TBD	TBD	DH6	3900	TBD	TBD	TBD	TBD	SCD 20	F
3F3	Y	750	750	DH7	4400	DH6	4500	TBD	TBD	TBD	TBD	TBD	TBD	TBD	TBD	SCD 20	F
3F3	T	1000	000	DH8	5700	DH7	5700	TBD	TBD	TBD	TBD	TBD	TBD	TBD	TBD	SCD 10	F

W*/C*: Built-in Wall/Ceiling Mounting **OSHPD Certified for Floor Mounting Only Opt W/C: Wall/Ceiling Mounting Kit "DW3"

Series H Addendum

DOE 2016 3-Phase Dry Type Ventilated Transformer

K1 480V Delta 3-Phase Primary Series H

Primary: 3-Phase Delta 480V Secondary: 480Y/277 K-Factor: K-1				Temperature Rise 150C [Blank]				Temperature Rise 115C [F]				Temperature Rise 80C [B]				Wiring Diagram	Mounting Type
Phase/Voltage	Tap [x]	kVA [yyy]		Aluminum		Copper		Aluminum		Copper		Aluminum		Copper			
		kVA	yyy	Encl. Type	Weight	Encl. Type	Weight	Encl. Type	Weight	Encl. Type	Weight	Encl. Type	Weight	Encl. Type	Weight		
3F5	Y	15	015	DH1	210	DH1	210	TBD	TBD	TBD	TBD	TBD	TBD	TBD	TBD	SCD 19	F or W*/C*
3F5	Y	30	030	DH2	310	DH2	340	TBD	TBD	DH2	425	TBD	TBD	TBD	TBD	SCD 19	F or W*/C*
3F5	Y	45	045	DH2	380	DH2	400	TBD	TBD	DH3	645	TBD	TBD	TBD	TBD	SCD 19	F or W*/C*
3F5	Y	75	075	DH3	510	DH3	590	TBD	TBD	TBD	TBD	TBD	TBD	TBD	TBD	SCD 19	F (Opt W/C)
3F5	Y	112.5	112	DH3	680	DH3	740	TBD	TBD	TBD	TBD	TBD	TBD	TBD	TBD	SCD 19	F (Opt W/C)
3F5	Y	150	150	DH4	870	DH4	930	TBD	TBD	DH4	1050	TBD	TBD	TBD	TBD	SCD 19	F
3F5	Y	225	225	DH5	1350	DH4	1350	TBD	TBD	TBD	TBD	TBD	TBD	TBD	TBD	SCD 19	F
3F5	Y	300	300	DH5	1800	DH5	1800	TBD	TBD	TBD	TBD	TBD	TBD	TBD	TBD	SCD 19	F
3F5	Y	500	500	DH6	2750	DH6	3200	TBD	TBD	TBD	TBD	TBD	TBD	TBD	TBD	SCD 20	F
3F5	Y	750	750	DH7	4100	DH6	4050	TBD	TBD	TBD	TBD	TBD	TBD	TBD	TBD	SCD 20	F
3F5	T	1000	000	DH8	5400	DH7	5200	TBD	TBD	TBD	TBD	TBD	TBD	TBD	TBD	SCD 10	F

W*/C*: Built-in Wall/Ceiling Mounting **OSHPD Certified for Floor Mounting Only Opt W/C: Wall/Ceiling Mounting Kit "DW3"

Primary: 3-Phase Delta 480V Secondary: 480Y/277 K-Factor: K-4				Temperature Rise 150C [Blank]				Temperature Rise 115C [F]				Temperature Rise 80C [B]				Wiring Diagram	Mounting Type
Phase/Voltage	Tap [x]	kVA [yyy]		Aluminum		Copper		Aluminum		Copper		Aluminum		Copper			
		kVA	yyy	Encl. Type	Weight	Encl. Type	Weight	Encl. Type	Weight	Encl. Type	Weight	Encl. Type	Weight	Encl. Type	Weight		
3F5	Y	15	015	DH1	220	DH1	220	TBD	TBD	TBD	TBD	TBD	TBD	TBD	TBD	SCD 19	F or W*/C*
3F5	Y	30	030	DH2	320	DH2	350	DH2	300	TBD	TBD	TBD	TBD	TBD	TBD	SCD 19	F or W*/C*
3F5	Y	45	045	DH2	390	DH2	410	DH2	395	TBD	TBD	TBD	TBD	TBD	TBD	SCD 19	F or W*/C*
3F5	Y	75	075	DH3	530	DH3	600	DH3	560	DH3	775	TBD	TBD	TBD	TBD	SCD 19	F (Opt W/C)
3F5	Y	112.5	112	DH3	690	DH3	760	DH4	915	DH4	1000	TBD	TBD	TBD	TBD	SCD 19	F (Opt W/C)
3F5	Y	150	150	DH4	900	DH4	950	TBD	TBD	TBD	TBD	TBD	TBD	TBD	TBD	SCD 19	F
3F5	Y	225	225	DH5	1380	DH4	1380	TBD	TBD	TBD	TBD	TBD	TBD	TBD	TBD	SCD 19	F
3F5	Y	300	300	DH5	1830	DH5	1830	TBD	TBD	DH5	2450	TBD	TBD	TBD	TBD	SCD 19	F
3F5	Y	500	500	DH6	2800	DH6	3250	TBD	TBD	TBD	TBD	TBD	TBD	TBD	TBD	SCD 20	F
3F5	Y	750	750	DH7	4200	DH6	4100	TBD	TBD	TBD	TBD	TBD	TBD	TBD	TBD	SCD 20	F
3F5	T	1000	000	DH8	5500	DH7	5300	TBD	TBD	TBD	TBD	TBD	TBD	TBD	TBD	SCD 10	F

W*/C*: Built-in Wall/Ceiling Mounting **OSHPD Certified for Floor Mounting Only Opt W/C: Wall/Ceiling Mounting Kit "DW3"

Primary: 3-Phase Delta 480V Secondary: 480Y/277 K-Factor: K-13				Temperature Rise 150C [Blank]				Temperature Rise 115C [F]				Temperature Rise 80C [B]				Wiring Diagram	Mounting Type
Phase/Voltage	Tap [x]	kVA [yyy]		Aluminum		Copper		Aluminum		Copper		Aluminum		Copper			
		kVA	yyy	Encl. Type	Weight	Encl. Type	Weight	Encl. Type	Weight	Encl. Type	Weight	Encl. Type	Weight	Encl. Type	Weight		
3F5	Y	15	015	DH1	TBD	DH1	TBD	TBD	TBD	TBD	TBD	TBD	TBD	TBD	TBD	SCD 19	F or W*/C*
3F5	Y	30	030	DH2	TBD	DH2	TBD	TBD	TBD	TBD	TBD	TBD	TBD	TBD	TBD	SCD 19	F or W*/C*
3F5	Y	45	045	DH2	TBD	DH2	TBD	TBD	TBD	TBD	TBD	TBD	TBD	TBD	TBD	SCD 19	F or W*/C*
3F5	Y	75	075	DH3	TBD	DH3	TBD	TBD	TBD	TBD	TBD	TBD	TBD	TBD	TBD	SCD 19	F (Opt W/C)
3F5	Y	112.5	112	DH3	TBD	DH3	TBD	TBD	TBD	TBD	TBD	TBD	TBD	TBD	TBD	SCD 19	F (Opt W/C)
3F5	Y	150	150	DH4	TBD	DH4	TBD	TBD	TBD	TBD	TBD	TBD	TBD	TBD	TBD	SCD 19	F
3F5	Y	225	225	DH5	TBD	DH4	TBD	TBD	TBD	TBD	TBD	TBD	TBD	TBD	TBD	SCD 19	F
3F5	Y	300	300	DH5	TBD	DH5	TBD	TBD	TBD	TBD	TBD	TBD	TBD	TBD	TBD	SCD 19	F
3F5	Y	500	500	DH6	TBD	DH6	TBD	TBD	TBD	TBD	TBD	TBD	TBD	TBD	TBD	SCD 20	F
3F5	Y	750	750	DH7	TBD	DH6	TBD	TBD	TBD	TBD	TBD	TBD	TBD	TBD	TBD	SCD 20	F
3F5	T	1000	000	DH8	TBD	DH7	TBD	TBD	TBD	TBD	TBD	TBD	TBD	TBD	TBD	SCD 10	F

W*/C*: Built-in Wall/Ceiling Mounting **OSHPD Certified for Floor Mounting Only Opt W/C: Wall/Ceiling Mounting Kit "DW3"

DOE 2016 3-Phase Dry Type Ventilated Transformer

K1 600V Delta 3-Phase Primary Series H

Primary: 3-Phase Delta 600V Secondary: 208Y/120V K-Factor: K-1				Temperature Rise 150C [Blank]				Temperature Rise 115C [F]				Temperature Rise 80C [B]				Wiring Diagram	Mounting Type
Phase/Voltage	Tap [x]	kVA [yyy]		Aluminum		Copper		Aluminum		Copper		Aluminum		Copper			
		kVA	yyy	Encl. Type	Weight	Encl. Type	Weight	Encl. Type	Weight	Encl. Type	Weight	Encl. Type	Weight	Encl. Type	Weight		
3G3	Y	15	015	DH1	210	DH1	210	TBD	TBD	TBD	TBD	TBD	TBD	TBD	TBD	SCD 19	F or W*/C*
3G3	Y	30	030	DH2	310	DH2	340	TBD	TBD	TBD	TBD	TBD	TBD	TBD	TBD	SCD 19	F or W*/C*
3G3	Y	45	045	DH2	380	DH2	400	TBD	TBD	TBD	TBD	TBD	TBD	TBD	TBD	SCD 19	F or W*/C*
3G3	Y	75	075	DH3	510	DH3	590	TBD	TBD	TBD	TBD	TBD	TBD	TBD	TBD	SCD 19	F (Opt W/C)
3G3	Y	112.5	112	DH3	680	DH3	740	TBD	TBD	TBD	TBD	TBD	TBD	TBD	TBD	SCD 19	F (Opt W/C)
3G3	Y	150	150	DH4	870	DH4	930	TBD	TBD	TBD	TBD	TBD	TBD	TBD	TBD	SCD 19	F
3G3	Y	225	225	DH5	1350	DH4	1350	TBD	TBD	TBD	TBD	TBD	TBD	TBD	TBD	SCD 19	F
3G3	Y	300	300	DH5	1800	DH5	1800	TBD	TBD	TBD	TBD	TBD	TBD	TBD	TBD	SCD 19	F
3G3	Y	500	500	DH6	2750	DH6	3200	TBD	TBD	TBD	TBD	TBD	TBD	TBD	TBD	SCD 20	F
3G3	Y	750	750	DH7	4100	DH6	4050	TBD	TBD	TBD	TBD	TBD	TBD	TBD	TBD	SCD 20	F
3G3	T	1000	000	DH8	5400	DH7	5200	TBD	TBD	TBD	TBD	TBD	TBD	TBD	TBD	SCD 10	F

W*/C*: Built-in Wall/Ceiling Mounting **OSHPD Certified for Floor Mounting Only Opt W/C: Wall/Ceiling Mounting Kit "DW3"

Primary: 3-Phase Delta 600V Secondary: 208Y/120V K-Factor: K-4				Temperature Rise 150C [Blank]				Temperature Rise 115C [F]				Temperature Rise 80C [B]				Wiring Diagram	Mounting Type
Phase/Voltage	Tap [x]	kVA [yyy]		Aluminum		Copper		Aluminum		Copper		Aluminum		Copper			
		kVA	yyy	Encl. Type	Weight	Encl. Type	Weight	Encl. Type	Weight	Encl. Type	Weight	Encl. Type	Weight	Encl. Type	Weight		
3G3	Y	15	015	DH1	220	DH1	220	TBD	TBD	TBD	TBD	TBD	TBD	TBD	TBD	SCD 19	F or W*/C*
3G3	Y	30	030	DH2	320	DH2	350	TBD	TBD	TBD	TBD	TBD	TBD	TBD	TBD	SCD 19	F or W*/C*
3G3	Y	45	045	DH2	390	DH2	410	TBD	TBD	TBD	TBD	TBD	TBD	TBD	TBD	SCD 19	F or W*/C*
3G3	Y	75	075	DH3	530	DH3	600	TBD	TBD	TBD	TBD	TBD	TBD	TBD	TBD	SCD 19	F (Opt W/C)
3G3	Y	112.5	112	DH3	690	DH3	760	TBD	TBD	TBD	TBD	TBD	TBD	TBD	TBD	SCD 19	F (Opt W/C)
3G3	Y	150	150	DH4	900	DH4	950	TBD	TBD	TBD	TBD	TBD	TBD	TBD	TBD	SCD 19	F
3G3	Y	225	225	DH5	1380	DH4	1380	TBD	TBD	TBD	TBD	TBD	TBD	TBD	TBD	SCD 19	F
3G3	Y	300	300	DH5	1830	DH5	1830	TBD	TBD	TBD	TBD	TBD	TBD	TBD	TBD	SCD 19	F
3G3	Y	500	500	DH6	2/800	DH6	3250	TBD	TBD	TBD	TBD	TBD	TBD	TBD	TBD	SCD 20	F
3G3	Y	750	750	DH7	4200	DH6	4100	TBD	TBD	TBD	TBD	TBD	TBD	TBD	TBD	SCD 20	F
3G3	T	1000	000	DH8	5500	DH7	5300	TBD	TBD	TBD	TBD	TBD	TBD	TBD	TBD	SCD 10	F

W*/C*: Built-in Wall/Ceiling Mounting **OSHPD Certified for Floor Mounting Only Opt W/C: Wall/Ceiling Mounting Kit "DW3"

Primary: 3-Phase Delta 600V Secondary: 208Y/120V K-Factor: K-13				Temperature Rise 150C [Blank]				Temperature Rise 115C [F]				Temperature Rise 80C [B]				Wiring Diagram	Mounting Type
Phase/Voltage	Tap [x]	kVA [yyy]		Aluminum		Copper		Aluminum		Copper		Aluminum		Copper			
		kVA	yyy	Encl. Type	Weight	Encl. Type	Weight	Encl. Type	Weight	Encl. Type	Weight	Encl. Type	Weight	Encl. Type	Weight		
3G3	Y	15	015	DH1	240	DH1	240	TBD	TBD	TBD	TBD	TBD	TBD	TBD	TBD	SCD 19	F or W*/C*
3G3	Y	30	030	DH2	340	DH2	370	TBD	TBD	TBD	TBD	TBD	TBD	TBD	TBD	SCD 19	F or W*/C*
3G3	Y	45	045	DH2	420	DH2	430	TBD	TBD	TBD	TBD	TBD	TBD	TBD	TBD	SCD 19	F or W*/C*
3G3	Y	75	075	DH3	560	DH3	620	TBD	TBD	TBD	TBD	TBD	TBD	TBD	TBD	SCD 19	F (Opt W/C)
3G3	Y	112.5	112	DH3	730	DH3	840	TBD	TBD	TBD	TBD	TBD	TBD	TBD	TBD	SCD 19	F (Opt W/C)
3G3	Y	150	150	DH4	1070	DH4	110	TBD	TBD	TBD	TBD	TBD	TBD	TBD	TBD	SCD 19	F
3G3	Y	225	225	DH5	1500	DH4	1620	TBD	TBD	TBD	TBD	TBD	TBD	TBD	TBD	SCD 19	F
3G3	Y	300	300	DH5	1950	DH5	2060	TBD	TBD	TBD	TBD	TBD	TBD	TBD	TBD	SCD 19	F
3G3	Y	500	500	DH6	2900	DH6	3400	TBD	TBD	TBD	TBD	TBD	TBD	TBD	TBD	SCD 20	F
3G3	Y	750	750	DH7	4400	DH6	4500	TBD	TBD	TBD	TBD	TBD	TBD	TBD	TBD	SCD 20	F
3G3	T	1000	000	DH8	5700	DH7	5700	TBD	TBD	TBD	TBD	TBD	TBD	TBD	TBD	SCD 10	F

W*/C*: Built-in Wall/Ceiling Mounting **OSHPD Certified for Floor Mounting Only Opt W/C: Wall/Ceiling Mounting Kit "DW3"

Series H Addendum

DOE 2016 3-Phase Dry Type Ventilated Transformer

K1 600V Delta 3-Phase Primary Series H

Primary: 3-Phase Delta 600V Secondary: 480Y/277 K-Factor: K-1				Temperature Rise 150C [Blank]				Temperature Rise 115C [F]				Temperature Rise 80C [B]				Wiring Diagram	Mounting Type
		3G5xyyyD16		3G5xyyyCD16		3G5xyyyFD16		3G5xyyyFCD16		3G5xyyyBD16		3G5xyyyBCD16					
Phase/Voltage	Tap [x]	kVA [yyy]		Aluminum		Copper		Aluminum		Copper		Aluminum		Copper			
		kVA	yyy	Encl. Type	Weight	Encl. Type	Weight	Encl. Type	Weight	Encl. Type	Weight	Encl. Type	Weight	Encl. Type	Weight		
3G5	Y	15	015	DH1	210	DH1	210	TBD	TBD	TBD	TBD	TBD	TBD	TBD	TBD	SCD 19	F or W*/C*
3G5	Y	30	030	DH2	310	DH2	340	TBD	TBD	TBD	TBD	TBD	TBD	TBD	TBD	SCD 19	F or W*/C*
3G5	Y	45	045	DH2	380	DH2	400	TBD	TBD	TBD	TBD	TBD	TBD	TBD	TBD	SCD 19	F or W*/C*
3G5	Y	75	075	DH3	510	DH3	590	TBD	TBD	TBD	TBD	TBD	TBD	TBD	TBD	SCD 19	F (Opt W/C)
3G5	Y	112.5	112	DH3	680	DH3	740	TBD	TBD	TBD	TBD	TBD	TBD	TBD	TBD	SCD 19	F (Opt W/C)
3G5	Y	150	150	DH4	870	DH4	930	TBD	TBD	TBD	TBD	TBD	TBD	TBD	TBD	SCD 19	F
3G5	Y	225	225	DH5	1350	DH4	1350	TBD	TBD	TBD	TBD	TBD	TBD	TBD	TBD	SCD 19	F
3G5	Y	300	300	DH5	1800	DH5	1800	TBD	TBD	TBD	TBD	TBD	TBD	TBD	TBD	SCD 19	F
3G5	Y	500	500	DH6	2750	DH6	3200	TBD	TBD	TBD	TBD	TBD	TBD	TBD	TBD	SCD 20	F
3G5	Y	750	750	DH7	4100	DH6	4050	TBD	TBD	TBD	TBD	TBD	TBD	TBD	TBD	SCD 20	F
3G5	T	1000	000	DH8	5400	DH7	5200	TBD	TBD	TBD	TBD	TBD	TBD	TBD	TBD	SCD 10	F

W*/C*: Built-in Wall/Ceiling Mounting **OSHPD Certified for Floor Mounting Only Opt W/C: Wall/Ceiling Mounting Kit "DW3"

Primary: 3-Phase Delta 600V Secondary: 480Y/277 K-Factor: K-4				Temperature Rise 150C [Blank]				Temperature Rise 115C [F]				Temperature Rise 80C [B]				Wiring Diagram	Mounting Type
		3G5xyyyK4D16		3G5xyyyK4CD16		3G5xyyyK4FD16		3G5xyyyK4FCD16		3G5xyyyK4BD16		3G5xyyyK4BCD16					
Phase/Voltage	Tap [x]	kVA [yyy]		Aluminum		Copper		Aluminum		Copper		Aluminum		Copper			
		kVA	yyy	Encl. Type	Weight	Encl. Type	Weight	Encl. Type	Weight	Encl. Type	Weight	Encl. Type	Weight	Encl. Type	Weight		
3G5	Y	15	015	DH1	220	DH1	220	TBD	TBD	TBD	TBD	TBD	TBD	TBD	TBD	SCD 19	F or W*/C*
3G5	Y	30	030	DH2	320	DH2	350	TBD	TBD	TBD	TBD	TBD	TBD	TBD	TBD	SCD 19	F or W*/C*
3G5	Y	45	045	DH2	390	DH2	410	TBD	TBD	TBD	TBD	TBD	TBD	TBD	TBD	SCD 19	F or W*/C*
3G5	Y	75	075	DH3	530	DH3	600	TBD	TBD	TBD	TBD	TBD	TBD	TBD	TBD	SCD 19	F (Opt W/C)
3G5	Y	112.5	112	DH3	690	DH3	760	TBD	TBD	TBD	TBD	TBD	TBD	TBD	TBD	SCD 19	F (Opt W/C)
3G5	Y	150	150	DH4	900	DH4	950	TBD	TBD	TBD	TBD	TBD	TBD	TBD	TBD	SCD 19	F
3G5	Y	225	225	DH5	1380	DH4	1380	TBD	TBD	TBD	TBD	TBD	TBD	TBD	TBD	SCD 19	F
3G5	Y	300	300	DH5	830	DH5	1830	TBD	TBD	TBD	TBD	TBD	TBD	TBD	TBD	SCD 19	F
3G5	Y	500	500	DH6	2800	DH6	3250	TBD	TBD	TBD	TBD	TBD	TBD	TBD	TBD	SCD 20	F
3G5	Y	750	750	DH7	4200	DH6	4100	TBD	TBD	TBD	TBD	TBD	TBD	TBD	TBD	SCD 20	F
3G5	T	1000	000	DH8	5500	DH7	5300	TBD	TBD	TBD	TBD	TBD	TBD	TBD	TBD	SCD 10	F

W*/C*: Built-in Wall/Ceiling Mounting **OSHPD Certified for Floor Mounting Only Opt W/C: Wall/Ceiling Mounting Kit "DW3"

Primary: 3-Phase Delta 600V Secondary: 480Y/277 K-Factor: K-13				Temperature Rise 150C [Blank]				Temperature Rise 115C [F]				Temperature Rise 80C [B]				Wiring Diagram	Mounting Type
		3G5xyyyK13D16		3G5xyyyK13CD16		3G5xyyyK13FD16		3G5xyyyK13FCD16		3G5xyyyK13BD16		3G5xyyyK13BCD16					
Phase/Voltage	Tap [x]	kVA [yyy]		Aluminum		Copper		Aluminum		Copper		Aluminum		Copper			
		kVA	yyy	Encl. Type	Weight	Encl. Type	Weight	Encl. Type	Weight	Encl. Type	Weight	Encl. Type	Weight	Encl. Type	Weight		
3G5	Y	15	015	DH1	TBD	DH1	TBD	TBD	TBD	TBD	TBD	TBD	TBD	TBD	TBD	SCD 19	F or W*/C*
3G5	Y	30	030	DH2	TBD	DH2	TBD	TBD	TBD	TBD	TBD	TBD	TBD	TBD	TBD	SCD 19	F or W*/C*
3G5	Y	45	045	DH2	TBD	DH2	TBD	TBD	TBD	TBD	TBD	TBD	TBD	TBD	TBD	SCD 19	F or W*/C*
3G5	Y	75	075	DH3	TBD	DH3	TBD	TBD	TBD	TBD	TBD	TBD	TBD	TBD	TBD	SCD 19	F (Opt W/C)
3G5	Y	112.5	112	DH3	TBD	DH3	TBD	TBD	TBD	TBD	TBD	TBD	TBD	TBD	TBD	SCD 19	F (Opt W/C)
3G5	Y	150	150	DH4	TBD	DH4	TBD	TBD	TBD	TBD	TBD	TBD	TBD	TBD	TBD	SCD 19	F
3G5	Y	225	225	DH5	TBD	DH4	TBD	TBD	TBD	TBD	TBD	TBD	TBD	TBD	TBD	SCD 19	F
3G5	Y	300	300	DH5	TBD	DH5	TBD	TBD	TBD	TBD	TBD	TBD	TBD	TBD	TBD	SCD 19	F
3G5	Y	500	500	DH6	TBD	DH6	TBD	TBD	TBD	TBD	TBD	TBD	TBD	TBD	TBD	SCD 20	F
3G5	Y	750	750	DH7	TBD	DH6	TBD	TBD	TBD	TBD	TBD	TBD	TBD	TBD	TBD	SCD 20	F
3G5	T	1000	000	DH8	TBD	DH7	TBD	TBD	TBD	TBD	TBD	TBD	TBD	TBD	TBD	SCD 10	F

W*/C*: Built-in Wall/Ceiling Mounting **OSHPD Certified for Floor Mounting Only Opt W/C: Wall/Ceiling Mounting Kit "DW3"

Wiring Diagrams

SCD 7 Transformer Wiring Diagram

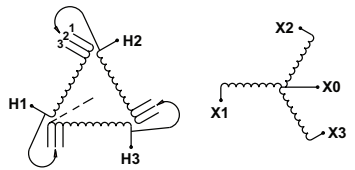
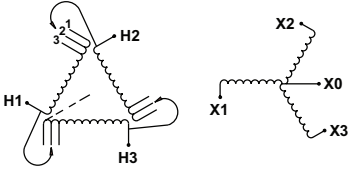
Diagram	% Voltage	Primary Volts								Coil Jumper To/ Interconnect	Connect Lines To	
		218	242	252	437	483	504	604	630			
	105.0%	218	242	252	437	483	504	604	630	1	H1, H2, H3	
	100.0%	208	230	240	416	460	480	575	600		2	H1, H2, H3
	95.0%	198	219	228	395	437	456	546	570		3	H1, H2, H3
		Secondary Volts									Connect Lines To	
		208	230	240	380	416	460	480	600		X1, X2, X3	
		120	133	139	220	240	265	277	347		X1,X0 X2,X0 X3,X0	
	100.0%	208 480								1	H1, H2, H3	
	95.0%	198 456									2	H1, H2, H3
	90.0%	187 432									3	H1, H2, H3
		Secondary Volts									Connect Lines To	
		208	230	240	380	416	460	480	600		X1, X2, X3	
		120	133	139	220	240	265	277	347		X1,X0 X2,X0 X3,X0	

SCD 8 Transformer Wiring Diagram

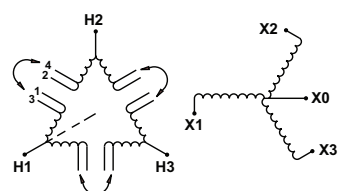
Diagram	% Voltage	Primary Volts										Coil Jumper To/ Interconnect	Connect Lines To	
		218	242	252	437	483	504	604	630	2520	4368			
	100.0%	218	242	252	437	483	504	604	630	2520	4368	1-2	H1, H2, H3	
	95.0%	208	230	240	416	460	480	575	600	2400	4160		2-3	H1, H2, H3
	90.0%	198	219	228	395	437	456	546	570	2280	3952		3-4	H1, H2, H3
		Secondary Volts											Connect Lines To	
		208	230	240	380	416	460	480	600				X1, X2, X3	
		120	133	139	220	240	265	277	347				X1,X0 X2,X0 X3,X0	

SCD 10 Transformer Wiring Diagram

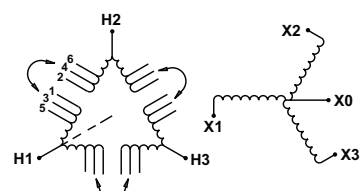
Diagram	% Voltage	Primary Volts										Coil Jumper To/ Interconnect	Connect Lines To	
		218	242	252	426	472	492	589	516	2460	4264			
	100.0%	218	242	252	437	483	504	604	630	2520	4368	1-2	H1, H2, H3	
	97.5%	213	236	246	426	472	492	589	516	2460	4264		2-3	H1, H2, H3
	95.0%	208	230	240	416	460	480	575	600	2400	4160		3-4	H1, H2, H3
	92.5%	203	224	234	406	449	468	561	585	2340	4056		4-5	H1, H2, H3
	90.0%	198	219	228	395	437	456	546	570	2280	3952		5-6	H1, H2, H3
		Secondary Volts											Connect Lines To	
		208	380	416	480	600							X1, X2, X3	
		120	220	240	277	347							X1,X0 X2,X0 X3,X0	

SCD 19 Transformer Wiring Diagram

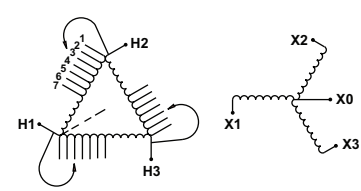
Diagram	% Voltage	Primary Volts				Coil Jumper To/ Interconnect	Connect Lines To	
		218	252	504	630			
	105.0%	218	252	504	630	1-2	H1, H2, H3	
	102.5%	213	246	492	615		2-3	H1, H2, H3
	100.0%	208	240	480	600		3-4	H1, H2, H3
	97.5%	203	234	468	585		4-5	H1, H2, H3
	95.0%	198	228	456	570		5-6	H1, H2, H3
	92.5%	193	222	444	556		6-7	H1, H2, H3
	90.0%	188	216	432	542		7-8	H1, H2, H3
			Secondary Volts					Connect Lines To
		208	480				X1, X2, X3	
		120	277				X1,X0 X2,X0 X3,X0	

Wiring Diagrams

SCD 20 Transformer Wiring Diagram

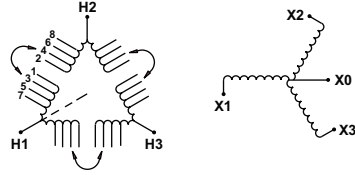
	% Voltage	Primary Volts	Coil Jumper To/ Interconnect	Connect Lines To
	105.0%	218 504 630 630	1-2	H1, H2, H3
102.5%	213 492 600 615	2-3	H1, H2, H3	
100.0%	208 480 570 600	3-4	H1, H2, H3	
97.5%	203 468 585	4-5	H1, H2, H3	
95.0%	198 456 504 570	5-6	H1, H2, H3	
92.5%	193 444 480 556	6-7	H1, H2, H3	
90.0%	188 432 456 542	7-8	H1, H2, H3	
		Secondary Volts	Connect Lines To	
		208 480	X1, X2, X3	
		120 277	X1,X0 X2,X0 X3,X0	

SCD 21 Transformer Wiring Diagram

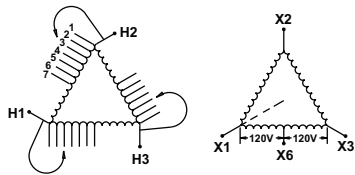
	% Voltage	Primary Volts	Coil Jumper To/ Interconnect	Connect Lines To
	105.0%	504	1	H1, H2, H3
102.5%	492	2	H1, H2, H3	
100.0%	480	3	H1, H2, H3	
97.5%	468	4	H1, H2, H3	
95.0%	456	5	H1, H2, H3	
92.5%	444	6	H1, H2, H3	
90.0%	432	7	H1, H2, H3	
		Secondary Volts	Connect Lines To	
		240	X1, X2, X3	
		120	X1,X6 X3,X6	

SCD 22 Transformer Wiring Diagram

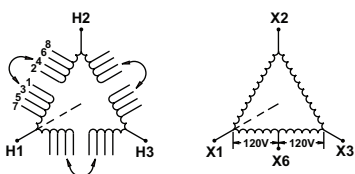
	% Voltage	Primary Volts	Coil Jumper To/ Interconnect	Connect Lines To
	105.0%	504	1-2	H1, H2, H3
102.5%	492	2-3	H1, H2, H3	
100.0%	480	3-4	H1, H2, H3	
97.5%	468	4-5	H1, H2, H3	
95.0%	456	5-6	H1, H2, H3	
92.5%	444	6-7	H1, H2, H3	
90.0%	432	7-8	H1, H2, H3	
		Secondary Volts	Connect Lines To	
		240	X1, X2, X3	
		120	X1,X6 X3,X6	

SCD 23 Transformer Wiring Diagram

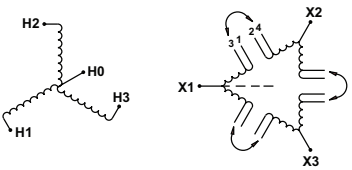
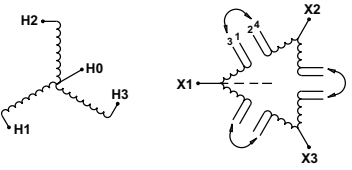
	% Voltage	Primary Volts	Coil Jumper To/ Interconnect	Connect Lines To
	105.0%	218 252	1-2	X1, X2, X3
100.0%	208 240	2-3	X1, X2, X3	
95.0%	198 228	3-4	X1, X2, X3	
		Secondary Volts	Connect Lines To	
		480	H1, H2, H3	
		277	H1,H0 H2,H0 H3,H0	
	% Voltage	Primary Volts	Coil Jumper To/ Interconnect	Connect Lines To
	100.0%	208 240	1-2	X1, X2, X3
95.0%	198 228	2-3	X1, X2, X3	
90.0%	188 216	3-4	X1, X2, X3	
		Secondary Volts	Connect Lines To	
		230 260 460 480	H1, H2, H3	
		133 139 265 277	H1,H0 H2,H0 H3,H0	

Wiring Diagrams

SCD 52 Transformer Wiring Diagram

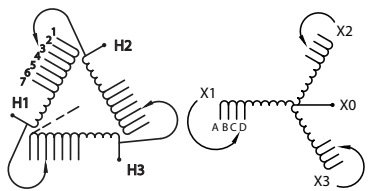
	% Voltage	Primary Volts	Coil Jumper To/ Interconnect	Connect Lines To
		105.0%	504	1
	102.5%	492	2	H1, H2, H3
	100.0%	480	3	H1, H2, H3
	97.5%	468	4	H1, H2, H3
	95.0%	456	5	H1, H2, H3
	92.5%	444	6	H1, H2, H3
	90.0%	432	7	H1, H2, H3
		Secondary Volts		Connect Lines To
	107.5%	430	A	X1, X2, X3
	104.0%	416	B	X1, X2, X3
	100.0%	400	C	X1, X2, X3
	95.0%	380	D	X1, X2, X3
		248	A	X1,X0 X2,X0 X3,X0
		240	B	X1,X0 X2,X0 X3,X0
		231	C	X1,X0 X2,X0 X3,X0
		219	D	X1,X0 X2,X0 X3,X0

SCD 53 Transformer Wiring Diagram

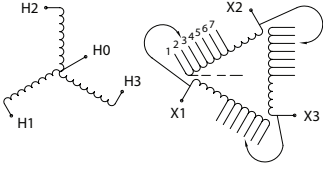
	% Voltage	Primary Volts	Coil Jumper To/ Interconnect	Connect Lines To
		95.0%	218 252	1
	92.5%	213 246	2	X1, X2, X3
	90.0%	208 240	3	X1, X2, X3
	90.0%	203 234	4	X1, X2, X3
	87.5%	198 228	5	X1, X2, X3
	85.0%	192 222	6	X1, X2, X3
	82.5%	187 216	7	X1, X2, X3
		Secondary Volts		Connect Lines To
		480		H1, H2, H3
		277		H1,H0 H2,H0 H3,H0

SCD 54 Transformer Wiring Diagram

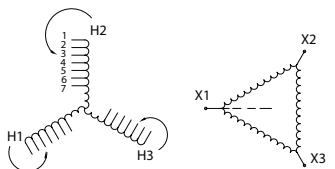
	% Voltage	Primary Volts	Coil Jumper To/ Interconnect	Connect Lines To
		105.0%	630	1
	102.5%	615	2	H1, H2, H3
	100.0%	600	3	H1, H2, H3
	97.5%	585	4	H1, H2, H3
	95.0%	570	5	H1, H2, H3
	92.5%	555	6	H1, H2, H3
	90.0%	540	7	H1, H2, H3
		Secondary Volts		Connect Lines To
		240		X1, X2, X3

SCD 56 Transformer Wiring Diagram

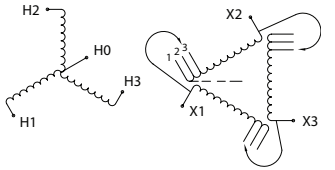
	% Voltage	Primary Volts	Coil Jumper To/ Interconnect	Connect Lines To
		105.0%	218 252	1
	100.0%	208 240	2	X1, X2, X3
	95.0%	198 228	3	X1, X2, X3
		Secondary Volts		Connect Lines To
		480		H1, H2, H3
		277		H1,H0 H2,H0 H3,H0

Wiring Diagrams

SCD 58 Transformer Wiring Diagram

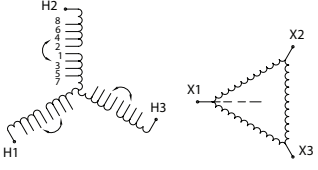
	% Voltage	Primary Volts	Coil Jumper To/ Interconnect	Connect Lines To
		2.5%	630	1-2
	2.5%	615	2-3	H1, H2, H3
	2.5%	600	3-4	H1, H2, H3
	2.5%	585	4-5	H1, H2, H3
	2.5%	570	5-6	H1, H2, H3
	2.5%	555	6-7	H1, H2, H3
	2.5%	540	7-8	H1, H2, H3
	Secondary Volts			Connect Lines To
		240		X1, X2, X3

SCD 59 Transformer Wiring Diagram

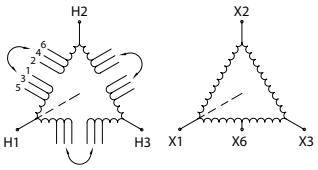
	% Voltage	Primary Volts	Coil Jumper To/ Interconnect	Connect Lines To
		105.0%	504	1-2
	102.5%	492	2-3	H1, H2, H3
	100.0%	480	3-4	H1, H2, H3
	97.5%	468	4-5	H1, H2, H3
	95.0%	456	5-6	H1, H2, H3
	Secondary Volts			Connect Lines To
		240		X1, X2, X3
		120		X1,X6 X3,X6

SCD 60 Transformer Wiring Diagram

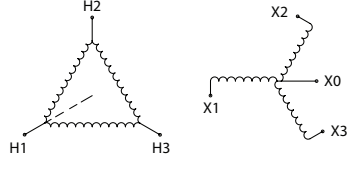
	% Voltage	Primary Volts	Coil Jumper To/ Interconnect	Connect Lines To
		100.0%	208 240	
	Secondary Volts			Connect Lines To
		208		X1, X2, X3
		120		X1,X0 X2,X0 X3,X0

SCD 61 Transformer Wiring Diagram

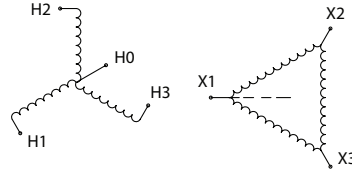
	% Voltage	Primary Volts	Coil Jumper To/ Interconnect	Connect Lines To
		100.0%	208 240	
	Secondary Volts			Connect Lines To
		480		H1, H2, H3
		277		H1,H0 H2,H0 H3,H0

Enclosure Drawings – Series H

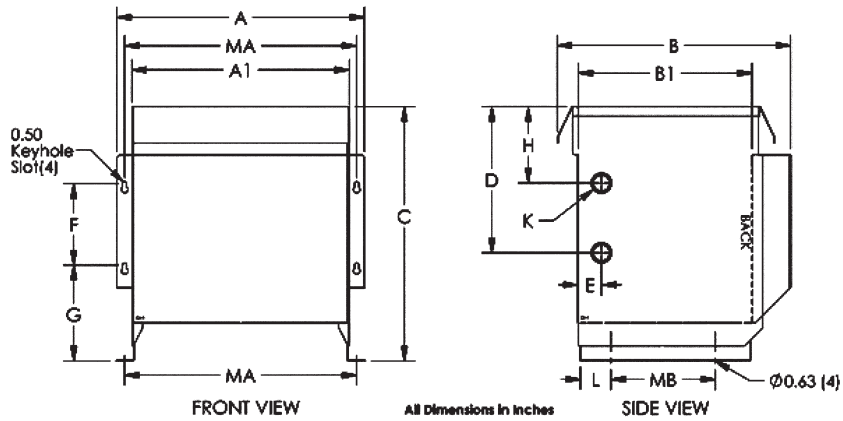

Case Style	Dimensions in Inches														
	A	A1	B	B1	C	D	E	F	G	H	K	L	MA	MB	
DH1	21.5	18.8	20.1	15	22	12.6	2	7	8.3	6.6	1.38 X 1.75 K.O.	2.6	20	9	
DH2	25.8	23.3	23.8	18	28.8	17	2	8	10.3	8.6	1.75 X 2.50 K.O.	3.8	24.6	9	

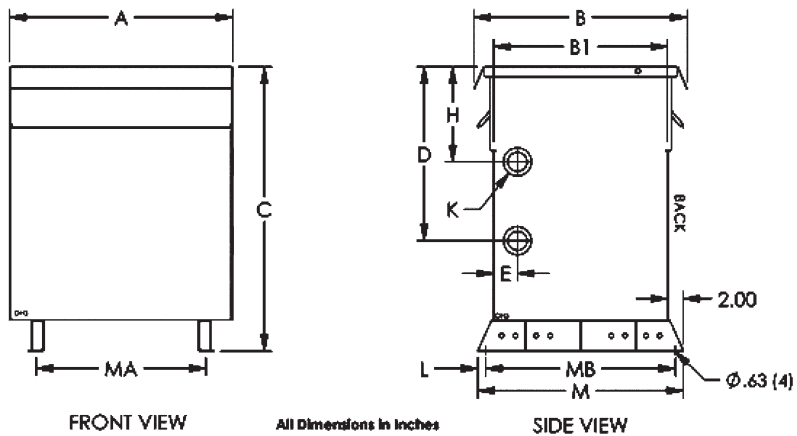

Case Style	Dimensions in Inches											
	A	B	B1	C	D	E	H	K	L	M	MA	MB
DH3	28.3	27	22	36	22	3	12	1.38 X 1.75 K.O.	1	26	21.5	24
DH4	31.5	29.5	24.5	44.5	27.5	3	14.5	1.75 X 2.50 K.O.	1	28.5	23.5	26.5

Enclosure Drawings – Series H

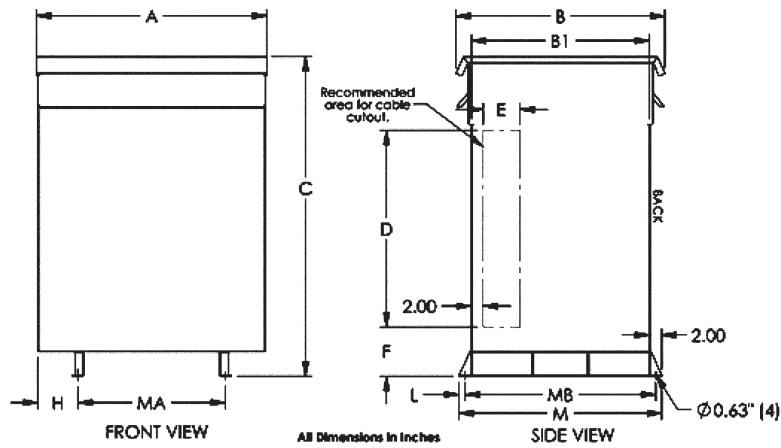

Case Style	Dimensions in Inches											
	A	B	B1	C	D	E	F	H	L	M	MA	MB
DH5	37.5	34	29	52	32	6	8	6.6	1	33	24	31

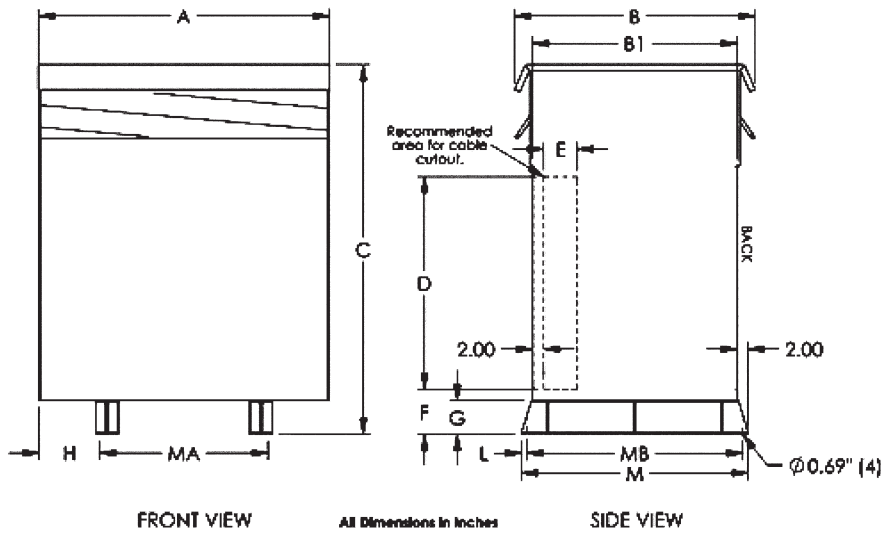

Case Style	Dimensions in Inches												
	A	B	B1	C	D	E	F	G	H	L	M	MA	MB
DH6	49	41.5	35	64	32	6	10	6	9.3	1	39	30	37
DH7	54	46.5	40	72	40	8	10	6	8.8	1	44	36	44
DH8	60	49.5	43	82	50	10	10	6	9.8	1	47	40	45
DH9	68	49.5	43	72	40	10	10	6	11.8	1	47	44	45
DH10	78	54.5	48	78	46	10	10	6	14.8	1	52	48	50

Termination Details – Type 3R – Series H

Single Phase, Aluminum and Copper Termination – Lugs Or Pads

kVA	VOLTAGE											
	120	120/240	208	240	277	347	380	416	480	600	2400	4160
0.25	Leads	Leads	Leads	Leads	Leads	Leads	Leads	Leads	Leads	Leads	—	—
0.5	Leads	Leads	Leads	Leads	Leads	Leads	Leads	Leads	Leads	Leads	—	—
0.75	Leads	Leads	Leads	Leads	Leads	Leads	Leads	Leads	Leads	Leads	—	—
1	Leads	Leads	Leads	Leads	Leads	Leads	Leads	Leads	Leads	Leads	—	—
1.5	Leads	Leads	Leads	Leads	Leads	Leads	Leads	Leads	Leads	Leads	—	—
2	Leads	Leads	Leads	Leads	Leads	Leads	Leads	Leads	Leads	Leads	—	—
3	Leads	Leads	Leads	Leads	Leads	Leads	Leads	Leads	Leads	Leads	—	—
5	Leads	Leads	Leads	Leads	Leads	Leads	Leads	Leads	Leads	Leads	—	—
7.5	Lugs	Lugs	Lugs	Lugs	Lugs	Lugs	Lugs	Lugs	Lugs	Lugs	—	—
10	Lugs	Lugs	Lugs	Lugs	Lugs	Lugs	Lugs	Lugs	Lugs	Lugs	—	—
15	Lugs	Lugs	Lugs	Lugs	Lugs	Lugs	Lugs	Lugs	Lugs	Lugs	Dia. 1A	Dia. 1A
25	Lugs	Lugs	Lugs	Lugs	Lugs	Lugs	Lugs	Lugs	Lugs	Lugs	Dia. 1A	Dia. 1A
37.5	Dia. 2	Lugs	Lugs	Lugs	Lugs	Lugs	Lugs	Lugs	Lugs	Lugs	Dia. 1A	Dia. 1A
50	Dia. 2	Lugs	Lugs	Lugs	Lugs	Lugs	Lugs	Lugs	Lugs	Lugs	Dia. 1A	Dia. 1A
75	Dia. 3	Dia. 2	Dia. 2	Dia. 2	Lugs	Lugs	Lugs	Lugs	Lugs	Lugs	Dia. 1A	Dia. 1A
100	Dia. 3	Dia. 2	Dia. 2	Dia. 2	Dia. 2	Dia. 2	Lugs	Lugs	Lugs	Lugs	Dia. 1A	Dia. 1A
150	Dia. 3	Dia. 3	Dia. 3	Dia. 3	Dia. 2	Dia. 2	Dia. 2	Dia. 2	Dia. 2	Lugs	Dia. 1A	Dia. 1A
167	Dia. 3	Dia. 3	Dia. 3	Dia. 3	Dia. 3	Dia. 2	Dia. 2	Dia. 2	Dia. 2	Dia. 2	Dia. 1A	Dia. 1A

Three Phase, Aluminum and Copper Termination – Lugs Or Pads

kVA	VOLTAGE									
	208	230	240	277	380	416	480	600	2400	4160
2	Leads	Leads	Leads	Leads	Leads	Leads	Leads	Leads	—	—
3	Leads	Leads	Leads	Leads	Leads	Leads	Leads	Leads	—	—
6	Leads	Leads	Leads	Leads	Leads	Leads	Leads	Leads	—	—
9	Lugs	Lugs	Lugs	Lugs	Lugs	Lugs	Lugs	Lugs	—	—
15	Lugs	Lugs	Lugs	Lugs	Lugs	Lugs	Lugs	Lugs	Dia. 1A	Dia. 1A
30	Lugs	Lugs	Lugs	Lugs	Lugs	Lugs	Lugs	Lugs	Dia. 1A	Dia. 1A
45	Lugs	Lugs	Lugs	Lugs	Lugs	Lugs	Lugs	Lugs	Dia. 1A	Dia. 1A
75	Lugs	Lugs	Lugs	Lugs	Lugs	Lugs	Lugs	Lugs	Dia. 1A	Dia. 1A
112.5	Lugs**	Dia. 1B	Lugs	Lugs	Lugs	Lugs	Lugs	Lugs	Dia. 1A	Dia. 1A
150	Dia. 1B	Dia. 1B	Dia. 1B	Dia. 1B	Lugs	Lugs	Lugs	Lugs	Dia. 1A	Dia. 1A
225	Dia. 2	Dia. 1B	Dia. 1B	Dia. 1B	Dia. 1B	Dia. 1B	Lugs	Lugs	Dia. 1A	Dia. 1A
300	Dia. 2	Dia. 2	Dia. 2	Dia. 2	Dia. 1B	Dia. 1B	Dia. 1B	Dia. 1B	Dia. 1A	Dia. 1A
500	Dia. 3	Dia. 3	Dia. 3	Dia. 3	Dia. 3	Dia. 2	Dia. 2	Dia. 1B	Dia. 1A	Dia. 1A
600	Dia. 3	Dia. 3	Dia. 3	Dia. 3	Dia. 3	Dia. 2	Dia. 2	Dia. 1B	Dia. 1A	Dia. 1A
750	Dia. 3	Dia. 3	Dia. 3	Dia. 3	Dia. 3	Dia. 3	Dia. 3	Dia. 2	Dia. 1B	Dia. 1A

** Lugs only supplied standard on 600V primary to 208Y/120V secondary units.(excluding K-Factor transformers)
All other voltages supplied standard with Diagram 1B pads.

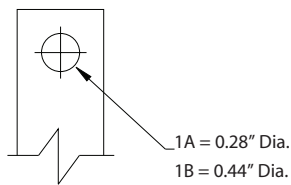

DIAGRAM 1

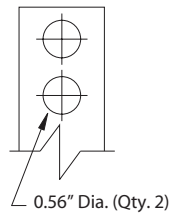

DIAGRAM 2

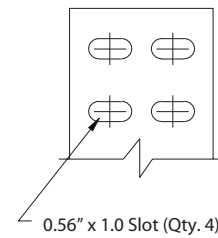

DIAGRAM 3

Series H Typical Performance Data

Dry Type 600 Volt Transformers

60 Hz, 10 kv BIL

K1 208Y/120V Secondary

Temp Rise 150° C

Catalog Number	kVA	No Load Loss Watts	Load Loss Watts	Impedance	Regulation						% Efficiency at different % of rated load							Page Number	Enclosure Type
					at 35% load		at 100% load		15%	25%	35%	50%	65%	75%	100%				
					pf = 1	pf = 0.8	pf = 1	pf = 0.8											
3F3Y015CD16	15	64	400	3.90%	0.93%	1.10%	2.68%	3.15%	97.86%	97.89%	97.67%	97.86%	97.67%	97.50%	97.00%	H-7	DH1		
3F3Y030CD16	30	96	760	4.00%	0.89%	1.17%	2.57%	3.35%	97.56%	98.13%	97.56%	98.13%	97.90%	97.72%	97.22%	H-7	DH2		
3F3Y045CD16	45	135	990	3.70%	0.77%	1.12%	2.22%	3.20%	97.72%	98.28%	97.72%	98.28%	98.15%	98.00%	97.57%	H-7	DH2		
3F3Y075CD16	75	194	1470	3.50%	0.69%	1.05%	1.98%	3.02%	98.02%	98.50%	98.02%	98.50%	98.36%	98.22%	97.84%	H-7	DH3		
3F3Y112CD16	112.5	275	1850	3.50%	0.58%	1.04%	1.68%	2.97%	98.16%	98.63%	98.16%	98.74%	98.70%	98.46%	98.14%	H-7	DH3		
3F3Y150CD16	150	335	2330	3.80%	0.55%	1.12%	1.61%	3.21%	98.31%	98.73%	98.31%	98.79%	98.79%	98.56%	98.25%	H-7	DH4		
3F3Y225CD16	225	440	3300	3.80%	0.52%	1.11%	1.52%	3.18%	98.50%	98.86%	98.50%	98.94%	98.79%	98.66%	98.36%	H-7	DH4		
3F3Y300CD16	300	560	3930	4.00%	0.47%	1.14%	1.38%	3.26%	98.58%	98.94%	98.58%	99.02%	98.87%	98.78%	98.53%	H-7	DH5		
3F3Y500CD16	500	808	5860	4.50%	0.42%	1.23%	1.26%	3.53%	98.76%	99.07%	99.14%	99.10%	99.00%	98.92%	98.68%	H-7	DH6		
3F3Y750CD16	750	980	8710	5.20%	0.42%	1.37%	1.28%	3.96%	98.97%	99.19%	99.23%	99.16%	99.05%	98.97%	98.72%	H-7	DH6		
3F3Y1000CD16	1000	1250	10400	5.20%	0.38%	1.36%	1.16%	3.91%	99.02%	99.25%	99.28%	99.24%	99.14%	99.07%	98.86%	H-7	DH7		

K1 208Y/120V Secondary

Temp Rise 115° C

Catalog Number	kVA	No Load Loss Watts	Load Loss Watts	Impedance	Regulation						% Efficiency at different % of rated load							Page Number	Enclosure Type
					at 35% load		at 100% load		15%	25%	35%	50%	65%	75%	100%				
					pf = 1	pf = 0.8	pf = 1	pf = 0.8											
3F3Y015FCD16	15	65	470	3.8%	0.92%	1.17%	2.65%	3.35%	96.82%	97.67%	97.89%	97.87%	97.68%	97.51%	97.03%	H-7	DH1		
3F3Y030FCD16	30	96	900	3.4%	0.88%	1.05%	2.53%	2.99%	97.55%	98.13%	98.23%	98.13%	97.91%	97.73%	97.24%	H-7	DH2		
3F3Y045FCD16	45	146	1070	3.4%	0.70%	1.06%	2.03%	3.04%	97.59%	98.23%	98.40%	98.38%	98.23%	98.10%	97.73%	H-7	DH3		
3F3Y075FCD16	75	187	1810	3.6%	0.72%	1.14%	2.07%	3.27%	98.07%	98.52%	98.60%	98.51%	98.32%	98.17%	97.76%	H-7	DH3		
3F3Y112FCD16	112.5	270	2250	3.3%	0.60%	1.02%	1.73%	2.91%	98.18%	98.63%	98.74%	98.69%	98.55%	98.43%	98.10%	H-7	DH3		
3F3Y150FCD16	150	353	2570	3.7%	0.52%	1.11%	1.53%	3.18%	98.24%	98.71%	98.83%	98.81%	98.70%	98.60%	98.32%	H-7	DH5		
3F3Y225FCD16	225	440	3820	3.3%	0.52%	1.01%	1.52%	2.88%	98.50%	98.86%	98.94%	98.88%	98.75%	98.65%	98.35%	H-7	DH5		
3F3Y300FCD16	300	500	5160	4.9%	0.53%	1.38%	1.59%	3.68%	98.68%	98.97%	99.02%	98.94%	98.80%	98.68%	98.38%	H-7	DH5		
3F3Y500FCD16	500	740	6400	6.3%	0.47%	1.66%	1.47%	4.80%	98.84%	99.10%	99.14%	99.07%	98.95%	98.86%	98.59%	H-7	DH6		
3F3Y750FCD16	750	970	8810	6.1%	0.43%	1.59%	1.35%	4.60%	98.97%	99.20%	99.23%	99.16%	99.05%	98.96%	98.71%	H-7	DH6		
3F3Y1000FCD16	1000	1100	11880	5.3%	0.43%	1.41%	1.32%	4.07%	99.10%	99.27%	99.28%	99.19%	99.07%	98.97%	98.72%	H-7	TBD		

K1 208Y/120V Secondary

Temp Rise 80° C

Catalog Number	kVA	No Load Loss Watts	Load Loss Watts	Impedance	Regulation						% Efficiency at different % of rated load							Page Number	Enclosure Type
					at 35% load		at 100% load		15%	25%	35%	50%	65%	75%	100%				
					pf = 1	pf = 0.8	pf = 1	pf = 0.8											
3F3Y015BCD16	15	72	365	2.7%	0.79%	0.85%	2.26%	2.43%	96.59%	97.58%	97.89%	97.96%	97.85%	97.72%	97.34%	H-7	DH1		
3F3Y030BCD16	30	125	570	2.8%	0.62%	0.92%	1.78%	2.62%	97.05%	97.94%	98.23%	98.32%	98.25%	98.16%	97.87%	H-7	DH2		
3F3Y045BCD16	45	168	770	2.7%	0.56%	0.89%	1.61%	2.54%	97.35%	98.14%	98.40%	98.48%	98.42%	98.34%	98.08%	H-7	DH3		
3F3Y075BCD16	75	237	1190	2.9%	0.52%	0.92%	1.51%	2.63%	97.73%	98.39%	98.60%	98.65%	98.57%	98.49%	98.24%	H-7	DH3		
3F3Y112BCD16	112.5	305	1720	2.7%	0.50%	0.88%	1.45%	2.51%	98.02%	98.58%	98.74%	98.76%	98.67%	98.59%	98.33%	H-7	DH3		
3F3Y150BCD16	150	392	2000	2.8%	0.44%	0.87%	1.28%	2.48%	98.11%	98.66%	98.83%	98.87%	98.80%	98.73%	98.51%	H-7	DH4		
3F3Y225BCD16	225	455	3400	4.4%	0.51%	1.28%	1.51%	3.66%	98.46%	98.85%	98.94%	98.90%	98.78%	98.60%	98.40%	H-7	DH5		
3F3Y300BCD16	300	560	4230	4.5%	0.47%	1.26%	1.40%	3.63%	98.58%	98.94%	99.02%	98.98%	98.87%	98.78%	98.52%	H-7	DH6		
3F3Y500BCD16	500	845	5420	5.1%	0.40%	1.36%	1.21%	3.93%	98.73%	99.06%	99.14%	99.13%	99.04%	98.97%	98.76%	H-7	DH6		
3F3Y750BCD16	750	1100	7700	5.4%	0.38%	1.40%	1.17%	4.05%	98.88%	99.16%	99.23%	99.20%	99.11%	99.04%	98.84%	H-7	DH8		
3F3Y1000BCD16	1000	1230	10810	5.1%	0.39%	1.36%	1.21%	3.91%	99.03%	99.24%	99.28%	99.22%	99.12%	99.03%	98.81%	H-7	TBD		

Series H Typical Performance Data

Dry Type 600 Volt Transformers

60 Hz, 10 kv BIL

Aluminum 3-Phase Delta 480V Primary			Temp Rise 150° C										K1 208Y/120V Secondary				
Catalog Number	kVA	No Load Loss Watts	Load Loss Watts	Impedance	Regulation				% Efficiency at different % of rated load						Page Number	Enclosure Type	
					at 35% load pf = 1	at 35% load pf = 0.8	at 100% load pf = 1	at 100% load pf = 0.8	15%	25%	35%	50%	65%	75%			100%
3F3Y015D16	15	62	420	4.0%	0.98%	1.12%	2.81%	3.21%	96.92%	97.70%	97.89%	97.82%	97.61%	97.42%	96.89%	H-7	DH1
3F3Y030D16	30	86	840	4.1%	0.98%	1.19%	2.82%	3.40%	97.72%	98.19%	98.23%	98.06%	97.79%	97.58%	97.00%	H-7	DH2
3F3Y045D16	45	120	1110	4.5%	0.97%	1.36%	2.51%	3.89%	97.90%	98.35%	98.40%	98.27%	98.03%	97.84%	97.34%	H-7	DH3
3F3Y075D16	75	190	1490	5.0%	0.71%	1.46%	2.08%	4.18%	98.05%	98.51%	98.60%	98.52%	98.35%	98.20%	97.81%	H-7	DH3
3F3Y112D16	112.5	226	2260	5.0%	0.71%	1.46%	2.10%	4.18%	98.38%	98.71%	98.74%	98.61%	98.41%	98.26%	97.84%	H-7	DH3
3F3Y150D16	150	315	2500	5.0%	0.60%	1.42%	1.77%	4.07%	98.38%	98.76%	98.83%	98.76%	98.61%	98.49%	98.16%	H-7	DH4
3F3Y225D16	225	405	3580	5.4%	0.57%	1.51%	1.72%	4.33%	98.58%	98.89%	98.94%	98.86%	98.70%	98.59%	98.26%	H-7	DH5
3F3Y300D16	300	540	4040	4.8%	0.48%	1.32%	1.45%	3.79%	98.62%	98.95%	99.02%	98.98%	98.86%	98.77%	98.50%	H-7	DH5
3F3Y500D16	500	840	5590	5.2%	0.41%	1.37%	1.24%	3.95%	98.73%	99.06%	99.14%	99.11%	99.02%	98.73%	H-7	DH6	
3F3Y750D16	750	1020	8370	5.8%	0.41%	1.50%	1.27%	4.35%	98.94%	99.18%	99.23%	99.18%	99.07%	98.99%	H-7	DH7	
3F3T000D16	1000	1180	11180	5.8%	0.41%	1.50%	1.28%	4.35%	99.05%	99.25%	99.28%	99.21%	99.10%	99.01%	H-7	DH8	

Aluminum 3-Phase Delta 480V Primary			Temp Rise 115° C										K1 208Y/120V Secondary				
Catalog Number	kVA	No Load Loss Watts	Load Loss Watts	Impedance	Regulation				% Efficiency at different % of rated load						Page Number	Enclosure Type	
					at 35% load pf = 1	at 35% load pf = 0.8	at 100% load pf = 1	at 100% load pf = 0.8	15%	25%	35%	50%	65%	75%			100%
3F3Y015FD16	15	62	505	4.1%	0.99%	1.28%	2.84%	3.67%	96.94%	97.71%	97.89%	97.82%	97.60%	97.41%	96.88%	H-7	DH2
3F3Y030FD16	30	105	820	3.5%	0.80%	1.09%	2.31%	3.11%	97.39%	98.07%	98.23%	98.19%	98.02%	97.86%	97.43%	H-7	DH2
3F3Y045FD16	45	120	1320	4.8%	0.87%	1.49%	2.53%	4.27%	97.89%	98.34%	98.40%	98.27%	98.03%	97.85%	97.35%	H-7	DH3
3F3Y075FD16	75	190	1770	4.7%	0.71%	1.42%	2.07%	4.08%	98.05%	98.51%	98.60%	98.52%	98.34%	98.20%	97.81%	H-7	DH3
3F3Y112FD16	112.5	240	2530	4.2%	0.67%	1.29%	1.97%	3.68%	98.32%	98.74%	98.83%	98.64%	98.46%	98.32%	97.92%	H-7	DH4
3F3Y150FD16	150	320	2900	3.7%	0.58%	1.13%	1.70%	3.22%	98.36%	98.75%	98.84%	98.76%	98.62%	98.50%	98.17%	H-7	DH5
3F3Y225FD16	225	360	4550	5.9%	0.63%	1.65%	1.91%	4.76%	98.69%	98.93%	98.94%	98.82%	98.63%	98.49%	98.12%	H-7	DH5
3F3Y300FD16	300	580	4400	4.0%	0.44%	1.13%	1.32%	3.26%	98.55%	98.93%	99.02%	99.00%	98.90%	98.82%	98.58%	H-7	DH5
3F3Y500FD16	500	780	6090	5.2%	0.44%	1.39%	1.34%	4.01%	98.79%	99.08%	99.14%	99.09%	98.98%	98.89%	98.64%	H-7	DH7
3F3Y750FD16	750	860	9630	7.5%	0.48%	1.95%	1.56%	5.65%	99.05%	99.23%	99.23%	99.14%	99.00%	98.90%	H-7	DH8	
3F3Y000FD16	1000	1100	11820	6.7%	0.44%	1.72%	1.40%	4.97%	99.10%	99.27%	99.28%	99.20%	99.07%	98.98%	H-7	TBD	

Aluminum 3-Phase Delta 480V Primary			Temp Rise 80° C										K1 208Y/120V Secondary				
Catalog Number	kVA	No Load Loss Watts	Load Loss Watts	Impedance	Regulation				% Efficiency at different % of rated load						Page Number	Enclosure Type	
					at 35% load pf = 1	at 35% load pf = 0.8	at 100% load pf = 1	at 100% load pf = 0.8	15%	25%	35%	50%	65%	75%			100%
3F3Y015BD16	15	63	445	3.5%	0.96%	1.06%	2.75%	3.03%	96.89%	97.65%	97.89%	97.84%	97.63%	97.45%	96.94%	H-7	DH2
3F3Y030BD16	30	110	700	3.3%	0.76%	1.08%	2.18%	3.09%	97.31%	98.03%	98.23%	98.22%	98.07%	97.94%	97.54%	H-7	DH2
3F3Y045BD16	45	145	980	3.6%	0.71%	1.18%	2.06%	3.37%	97.61%	98.24%	98.40%	98.37%	98.22%	98.09%	97.71%	H-7	DH3
3F3Y075BD16	75	200	1520	5.7%	0.68%	1.64%	2.03%	4.72%	97.98%	98.49%	98.60%	98.55%	98.39%	98.26%	97.89%	H-7	DH3
3F3Y112BD16	112.5	270	2030	5.8%	0.61%	1.64%	1.84%	4.72%	98.18%	98.64%	98.74%	98.69%	98.55%	98.44%	98.11%	H-7	DH4
3F3Y150BD16	150	350	2360	3.9%	0.52%	1.16%	1.54%	3.33%	98.25%	98.72%	98.83%	98.81%	98.70%	98.60%	98.32%	H-7	DH5
3F3Y225BD16	225	478	3240	4.4%	0.48%	1.24%	1.42%	3.57%	98.41%	98.83%	98.94%	98.92%	98.82%	98.73%	98.47%	H-7	DH5
3F3Y300BD16	300	510	4600	5.6%	0.52%	1.54%	1.57%	4.45%	98.67%	98.97%	99.02%	98.96%	98.82%	98.72%	98.43%	H-7	DH6
3F3Y500BD16	500	850	5480	5.4%	0.40%	1.43%	1.24%	4.12%	98.72%	99.05%	99.14%	99.12%	99.03%	98.96%	98.75%	H-7	DH7
3F3Y750BD16	750	1040	8240	5.1%	0.40%	1.37%	1.22%	3.94%	98.92%	99.18%	99.23%	99.18%	99.08%	99.00%	98.78%	H-7	TBD
3F3Y000BD16	1000	1270	10470	5.3%	0.38%	1.38%	1.18%	3.98%	99.01%	99.24%	99.28%	99.23%	99.13%	99.05%	98.84%	H-7	TBD

Series H Typical Performance Data

Dry Type 600 Volt Transformers

60 Hz, 10 kv BIL

K4 208Y/120V Secondary

Temp Rise 150° C

Catalog Number	kVA	No Load Loss Watts	Load Loss Watts	Impedance	Regulation						% Efficiency at different % of rated load							Page Number	Enclosure Type
					at 35% load		at 100% load		15%	25%	35%	50%	65%	75%	100%				
					pf = 1	pf = 0.8	pf = 1	pf = 0.8											
3F3Y015K4CD16	15	68	480	3.5%	0.86%	0.98%	2.46%	2.81%	96.71%	97.62%	97.89%	97.91%	97.76%	97.61%	97.17%	H-7	DH1		
3F3Y030K4CD16	30	107	870	3.8%	0.78%	1.13%	2.26%	3.22%	97.35%	98.05%	98.23%	98.20%	98.04%	97.90%	97.48%	H-7	DH2		
3F3Y045K4CD16	45	142	1150	3.8%	0.70%	1.16%	2.02%	3.31%	97.66%	98.28%	98.44%	98.41%	98.26%	98.13%	97.76%	H-7	DH2		
3F3Y075K4CD16	75	188	1950	3.6%	0.71%	1.10%	2.05%	3.14%	98.06%	98.51%	98.60%	98.51%	98.33%	98.19%	97.79%	H-7	DH3		
3F3Y112K4CD16	112.5	256	2570	3.9%	0.63%	1.18%	1.85%	3.38%	98.25%	98.66%	98.74%	98.67%	98.51%	98.38%	98.02%	H-7	DH3		
3F3Y150K4CD16	150	290	3450	5.1%	0.65%	1.47%	1.92%	4.21%	98.46%	98.79%	98.83%	98.72%	98.54%	98.41%	98.03%	H-7	DH4		
3F3Y225K4CD16	225	410	4400	3.7%	0.56%	1.64%	1.64%	3.20%	98.89%	98.94%	98.94%	98.85%	98.70%	98.59%	98.26%	H-7	DH4		
3F3Y300K4CD16	300	560	4940	3.8%	0.47%	1.08%	1.38%	3.10%	98.58%	98.94%	99.02%	98.98%	98.87%	98.78%	98.52%	H-7	DH5		
3F3Y500K4CD16	500	740	6380	5.5%	0.46%	1.48%	1.42%	4.26%	98.84%	99.10%	99.14%	99.07%	98.95%	98.86%	98.60%	H-7	DH6		
3F3Y750K4CD16	750	860	9710	6.7%	0.48%	1.75%	1.51%	5.05%	99.05%	99.22%	99.23%	99.13%	98.99%	98.89%	98.61%	H-7	DH6		
3F3Y000K4CD16	1000	1170	11300	5.0%	0.41%	1.32%	1.24%	3.81%	99.06%	99.25%	99.28%	99.21%	99.09%	99.01%	98.77%	H-7	DH7		

K4 208Y/120V Secondary

Temp Rise 115° C

Catalog Number	kVA	No Load Loss Watts	Load Loss Watts	Impedance	Regulation						% Efficiency at different % of rated load							Page Number	Enclosure Type
					at 35% load		at 100% load		15%	25%	35%	50%	65%	75%	100%				
					pf = 1	pf = 0.8	pf = 1	pf = 0.8											
3F3Y015K4FCD16	15	65	475	3.8%	0.93%	1.19%	2.68%	3.41%	96.84%	97.67%	97.89%	97.86%	97.67%	97.50%	97.00%	H-7	DH1		
3F3Y030K4FCD16	30	100	870	3.4%	0.86%	1.06%	2.45%	3.03%	97.48%	98.09%	98.23%	98.15%	97.95%	97.78%	97.30%	H-7	DH2		
3F3Y045K4FCD16	45	155	980	3.2%	0.65%	1.02%	1.86%	2.92%	97.49%	98.20%	98.40%	98.42%	98.31%	98.20%	97.87%	H-7	DH3		
3F3Y075K4FCD16	75	203	1640	3.2%	0.65%	1.02%	1.88%	2.92%	97.96%	98.48%	98.60%	98.55%	98.41%	98.28%	97.92%	H-7	DH3		
3F3Y112K4FCD16	112.5	270	2250	3.3%	0.60%	1.02%	1.73%	2.93%	98.18%	98.63%	98.74%	98.69%	98.55%	98.43%	98.10%	H-7	DH4		
3F3Y150K4FCD16	150	310	2950	4.7%	0.60%	1.37%	1.77%	3.94%	98.40%	98.77%	98.83%	98.76%	98.61%	98.49%	98.15%	H-7	DH4		
3F3Y225K4FCD16	225	440	3820	3.4%	0.52%	1.04%	1.52%	2.97%	98.50%	98.86%	98.94%	98.88%	98.75%	98.65%	98.35%	H-7	DH5		
3F3Y300K4FCD16	300	540	4770	4.9%	0.49%	1.36%	1.48%	3.90%	98.61%	98.95%	99.02%	98.96%	98.84%	98.75%	98.47%	H-7	DH5		
3F3Y500K4FCD16	500	770	6070	5.7%	0.44%	1.50%	1.36%	4.33%	98.81%	99.09%	99.14%	99.09%	98.98%	98.90%	98.65%	H-7	TBD		
3F3Y750K4FCD16	750	980	8640	6.1%	0.43%	1.59%	1.33%	4.60%	98.97%	99.20%	99.23%	99.17%	99.06%	98.97%	98.73%	H-7	TBD		
3F3Y000K4FCD16	1000	1200	11040	4.4%	0.40%	1.19%	1.19%	3.43%	99.04%	99.25%	99.28%	99.21%	99.11%	99.02%	98.79%	H-7	TBD		

K4 208Y/120V Secondary

Temp Rise 80° C

Catalog Number	kVA	No Load Loss Watts	Load Loss Watts	Impedance	Regulation						% Efficiency at different % of rated load							Page Number	Enclosure Type
					at 35% load		at 100% load		15%	25%	35%	50%	65%	75%	100%				
					pf = 1	pf = 0.8	pf = 1	pf = 0.8											
3F3Y015K4BCD16	15	73	350	2.7%	0.76%	0.87%	2.17%	2.49%	96.54%	97.56%	97.89%	97.98%	97.89%	97.78%	97.42%	H-7	DH1		
3F3Y030K4BCD16	30	120	610	2.9%	0.66%	0.96%	1.91%	2.73%	97.14%	97.97%	98.23%	98.29%	98.19%	98.09%	97.77%	H-7	DH2		
3F3Y045K4BCD16	45	165	800	2.8%	0.58%	0.92%	1.67%	2.64%	97.38%	98.16%	98.40%	98.47%	98.39%	98.30%	98.02%	H-7	DH2		
3F3Y075K4BCD16	75	225	1300	2.7%	0.57%	0.88%	1.63%	2.50%	97.81%	98.42%	98.60%	98.61%	98.51%	98.42%	98.13%	H-7	DH3		
3F3Y112K4BCD16	112.5	290	1870	3.0%	0.55%	0.96%	1.58%	2.74%	98.09%	98.60%	98.74%	98.73%	98.62%	98.52%	98.23%	H-7	DH3		
3F3Y150K4BCD16	150	394	2000	3.0%	0.44%	0.91%	1.28%	2.61%	98.10%	98.66%	98.83%	98.86%	98.80%	98.73%	98.51%	H-7	DH4		
3F3Y225K4BCD16	225	460	3160	4.4%	0.50%	1.27%	1.50%	3.66%	98.46%	98.85%	99.04%	98.90%	98.78%	98.69%	98.41%	H-7	DH5		
3F3Y300K4BCD16	300	560	4250	4.5%	0.47%	1.28%	1.41%	3.68%	98.58%	98.94%	99.02%	98.98%	98.87%	98.78%	98.52%	H-7	DH5		
3F3Y500K4BCD16	500	845	5490	5.3%	0.40%	1.40%	1.23%	4.05%	98.73%	99.06%	99.14%	99.12%	98.94%	98.96%	98.75%	H-7	TBD		
3F3Y750K4BCD16	750	1060	8050	6.1%	0.40%	1.57%	1.25%	4.55%	98.91%	99.17%	99.23%	99.19%	99.09%	99.02%	98.80%	H-7	TBD		
3F3Y000K4BCD16	1000	1200	11050	5.7%	0.41%	1.49%	1.26%	4.30%	99.04%	99.25%	99.28%	99.21%	99.11%	99.02%	98.79%	H-7	TBD		

Series H Typical Performance Data

Dry Type 600 Volt Transformers

60 Hz, 10 kv BIL

Aluminum 3-Phase Delta 480V Primary			Temp Rise 150° C										K4 208Y/120V Secondary				
Catalog Number	kVA	No Load Loss Watts	Load Loss Watts	Impedance	Regulation		% Efficiency at different % of rated load					Page Number	Enclosure Type				
					at 35% load	at 100% load	15%	25%	35%	50%	65%			75%	100%		
					pf = 1	pf = 0.8	pf = 1	pf = 0.8	15%	25%	35%	50%	65%	75%	100%		
3F3Y015K4D16	15	51	670	5.0%	1.19%	1.42%	3.42%	4.06%	97.30%	97.84%	97.89%	97.68%	97.34%	97.09%	96.40%	H-7	DH1
3F3Y030K4D16	30	85	1110	5.2%	1.00%	1.56%	2.89%	4.46%	97.73%	98.19%	98.23%	98.06%	97.78%	97.56%	96.98%	H-7	DH2
3F3Y045K4D16	45	132	1320	3.7%	0.79%	1.10%	2.27%	3.15%	98.30%	98.30%	98.40%	98.32%	98.12%	97.97%	97.52%	H-7	DH2
3F3Y075K4D16	75	190	1920	4.6%	0.70%	1.35%	2.05%	3.88%	98.05%	98.51%	98.60%	98.53%	98.35%	98.21%	97.82%	H-7	DH3
3F3Y112K4D16	112.5	230	2850	6.0%	0.71%	1.71%	2.14%	4.93%	98.37%	98.70%	98.74%	98.62%	98.42%	98.27%	97.86%	H-7	DH3
3F3Y150K4D16	150	285	3500	4.6%	0.65%	1.36%	1.92%	3.90%	98.48%	98.79%	98.83%	98.72%	98.53%	98.39%	98.01%	H-7	DH4
3F3Y225K4D16	225	365	4860	5.6%	0.63%	1.58%	1.88%	4.55%	98.67%	98.93%	98.94%	98.82%	98.63%	98.50%	98.13%	H-7	DH5
3F3Y300K4D16	300	505	5850	4.6%	0.52%	1.29%	1.55%	3.71%	98.68%	98.97%	99.02%	98.94%	98.80%	98.69%	98.39%	H-7	DH5
3F3Y500K4D16	500	820	5770	5.2%	0.42%	1.38%	1.28%	3.99%	98.75%	99.05%	99.14%	99.10%	99.01%	98.70%	98.33%	H-7	DH6
3F3Y750K4D16	750	890	9470	7.0%	0.47%	1.80%	1.49%	5.21%	99.03%	99.22%	99.23%	99.14%	99.01%	98.64%	98.31%	H-7	DH7
3F3Y000K4D16	1000	1100	11880	6.4%	0.44%	1.64%	1.38%	4.76%	99.10%	99.27%	99.28%	99.19%	99.07%	98.97%	98.72%	H-7	DH8

Aluminum 3-Phase Delta 480V Primary			Temp Rise 115° C										K4 208Y/120V Secondary				
Catalog Number	kVA	No Load Loss Watts	Load Loss Watts	Impedance	Regulation		% Efficiency at different % of rated load					Page Number	Enclosure Type				
					at 35% load	at 100% load	15%	25%	35%	50%	65%			75%	100%		
					pf = 1	pf = 0.8	pf = 1	pf = 0.8	15%	25%	35%	50%	65%	75%	100%		
3F3Y015K4FD16	15	58	540	4.5%	1.06%	1.41%	3.04%	4.03%	97.07%	97.76%	97.89%	97.78%	97.52%	97.31%	96.72%	H-7	DH2
3F3Y030K4FD16	30	110	770	3.4%	0.75%	1.08%	2.17%	3.09%	97.31%	98.04%	98.23%	98.22%	98.08%	97.94%	97.55%	H-7	TBD
3F3Y045K4FD16	45	140	1130	4.3%	0.75%	1.32%	2.17%	3.77%	97.67%	98.26%	98.40%	98.35%	98.18%	98.04%	97.64%	H-7	DH3
3F3Y075K4FD16	75	195	1720	4.8%	0.69%	1.43%	2.02%	4.11%	98.02%	98.50%	98.60%	98.53%	98.37%	98.23%	97.85%	H-7	DH3
3F3Y112K4FD16	112.5	255	2390	4.2%	0.64%	1.26%	1.87%	3.61%	98.25%	98.66%	98.74%	98.66%	98.50%	98.37%	98.01%	H-7	TBD
3F3Y150K4FD16	150	295	3150	4.2%	0.63%	1.27%	1.86%	3.63%	98.45%	98.78%	98.83%	98.73%	98.56%	98.42%	98.05%	H-7	DH5
3F3Y225K4FD16	225	390	4280	6.3%	0.60%	1.73%	1.84%	4.99%	98.62%	98.90%	98.94%	98.84%	98.67%	98.55%	98.20%	H-7	DH5
3F3Y300K4FD16	300	550	4660	4.5%	0.47%	1.27%	1.41%	3.65%	98.60%	98.95%	99.02%	98.98%	98.87%	98.78%	98.52%	H-7	TBD
3F3Y500K4FD16	500	780	6000	5.3%	0.44%	1.41%	1.33%	4.05%	98.79%	99.08%	99.14%	99.10%	98.99%	98.90%	98.66%	H-7	TBD
3F3Y750K4FD16	750	840	9880	7.5%	0.49%	1.93%	1.59%	5.59%	99.07%	99.23%	99.23%	99.12%	98.98%	98.87%	98.59%	H-7	TBD
3F3Y000K4FD16	1000	1100	11880	6.8%	0.44%	1.74%	1.41%	5.03%	99.10%	99.27%	99.28%	99.19%	99.07%	98.97%	98.72%	H-7	TBD

Aluminum 3-Phase Delta 480V Primary			Temp Rise 80° C										K4 208Y/120V Secondary				
Catalog Number	kVA	No Load Loss Watts	Load Loss Watts	Impedance	Regulation		% Efficiency at different % of rated load					Page Number	Enclosure Type				
					at 35% load	at 100% load	15%	25%	35%	50%	65%			75%	100%		
					pf = 1	pf = 0.8	pf = 1	pf = 0.8	15%	25%	35%	50%	65%	75%	100%		
3F3Y015K4BD16	15	64	435	3.2%	0.94%	1.04%	2.69%	2.96%	96.86%	97.66%	97.89%	97.85%	97.66%	97.49%	96.99%	H-7	TBD
3F3Y030K4BD16	30	110	700	3.3%	0.76%	1.10%	2.19%	3.15%	97.31%	98.03%	98.23%	98.22%	98.07%	97.94%	97.54%	H-7	TBD
3F3Y045K4BD16	45	150	930	3.6%	0.68%	1.15%	1.96%	3.29%	97.55%	98.22%	98.40%	98.40%	98.27%	98.15%	97.80%	H-7	TBD
3F3Y075K4BD16	75	230	1250	4.4%	0.55%	1.28%	1.63%	3.68%	97.77%	98.41%	98.60%	98.63%	98.54%	98.45%	98.18%	H-7	TBD
3F3Y112K4BD16	112.5	298	1800	3.4%	0.53%	1.04%	1.54%	2.99%	98.05%	98.59%	98.74%	98.74%	98.64%	98.55%	98.27%	H-7	TBD
3F3Y150K4BD16	150	350	2390	4.1%	0.53%	1.21%	1.56%	3.47%	98.25%	98.71%	98.83%	98.80%	98.69%	98.59%	98.30%	H-7	TBD
3F3Y225K4BD16	225	470	3270	4.5%	0.48%	1.44%	1.44%	3.64%	98.43%	98.84%	98.94%	98.92%	98.81%	98.72%	98.46%	H-7	TBD
3F3Y300K4BD16	300	512	4600	5.7%	0.52%	1.57%	1.58%	4.53%	98.67%	98.97%	99.02%	98.96%	98.82%	98.72%	98.43%	H-7	TBD
3F3Y500K4BD16	500	810	5840	6.3%	0.43%	1.63%	1.36%	4.72%	98.76%	99.07%	99.14%	99.10%	99.00%	98.92%	98.69%	H-7	TBD
3F3Y750K4BD16	750	1020	8400	5.4%	0.41%	1.42%	1.26%	4.09%	98.94%	99.18%	99.23%	99.17%	99.07%	98.99%	98.76%	H-7	TBD
3F3Y000K4BD16	1000	1260	10570	5.6%	0.39%	1.45%	1.20%	4.18%	99.01%	99.24%	99.28%	99.23%	99.13%	99.05%	98.83%	H-7	TBD

Series H Typical Performance Data

Dry Type 600 Volt Transformers

60 Hz, 10 kv BIL

K13 208Y/120V Secondary

Temp Rise 150° C

Catalog Number	kVA	No Load Loss Watts	Load Loss Watts	Impedance	Regulation						% Efficiency at different % of rated load							Page Number	Enclosure Type
					at 35% load		at 100% load												
					pf = 1	pf = 0.8	pf = 1	pf = 0.8	15%	25%	35%	50%	65%	75%	100%				
3F3Y015K13CD16	15	63	537	4.3%	0.96%	1.27%	2.77%	3.64%	96.89%	97.69%	97.89%	97.84%	97.63%	97.45%	96.93%	H-7	DH1		
3F3Y030K13CD16	30	109	853	3.7%	0.77%	1.11%	2.22%	3.17%	98.04%	98.32%	98.23%	98.21%	98.06%	97.92%	97.51%	H-7	DH2		
3F3Y045K13CD16	45	143	1200	3.6%	0.72%	1.08%	2.08%	3.07%	97.63%	98.25%	98.40%	98.36%	98.21%	98.07%	97.68%	H-7	DH2		
3F3Y075K13CD16	75	188	1950	3.6%	0.71%	1.10%	2.05%	3.14%	98.06%	98.51%	98.60%	98.51%	98.33%	98.19%	97.79%	H-7	DH3		
3F3Y12K13CD16	112.5	240	2760	3.8%	0.67%	1.13%	1.95%	3.24%	98.32%	98.74%	98.69%	98.64%	98.45%	98.31%	97.92%	H-7	DH3		
3F3Y150K13CD16	150	350	2800	3.8%	0.52%	1.11%	1.54%	3.19%	98.25%	98.71%	98.83%	98.81%	98.70%	98.60%	98.32%	H-7	DH4		
3F3Y225K13CD16	225	420	4320	3.4%	0.55%	1.01%	1.59%	2.90%	98.54%	98.88%	98.94%	98.87%	98.72%	98.61%	98.29%	H-7	DH4		
3F3Y300K13CD16	300	500	5570	5.0%	0.53%	1.40%	1.59%	4.01%	98.68%	98.97%	99.02%	98.94%	98.80%	98.68%	98.38%	H-7	DH5		
3F3Y500K13CD16	500	790	5910	4.9%	0.43%	1.33%	1.29%	3.82%	98.78%	99.08%	99.14%	99.10%	99.00%	98.91%	98.68%	H-7	DH6		
3F3Y750K13CD16	750	970	8800	6.1%	0.43%	1.57%	1.35%	4.55%	98.97%	99.20%	99.23%	99.16%	99.05%	98.96%	98.71%	H-7	DH6		
3F3Y000K13CD16	1000	1165	11340	5.0%	0.41%	1.32%	1.25%	3.82%	99.06%	99.26%	99.28%	99.21%	99.09%	99.00%	98.76%	H-7	DH7		

K13 208Y/120V Secondary

Temp Rise 115° C

Catalog Number	kVA	No Load Loss Watts	Load Loss Watts	Impedance	Regulation						% Efficiency at different % of rated load							Page Number	Enclosure Type
					at 35% load		at 100% load												
					pf = 1	pf = 0.8	pf = 1	pf = 0.8	15%	25%	35%	50%	65%	75%	100%				
3F3Y015K13FCD16	15	65	475	3.8%	0.93%	1.19%	2.68%	3.41%	96.84%	97.67%	97.89%	97.86%	97.67%	97.50%	97.00%	H-7	DH1		
3F3Y030K13FCD16	30	110	770	3.2%	0.76%	1.01%	2.18%	2.88%	97.31%	98.03%	98.23%	98.22%	98.07%	97.94%	97.54%	H-7	DH2		
3F3Y045K13FCD16	45	160	940	2.7%	0.62%	0.84%	1.77%	2.40%	97.43%	98.17%	98.40%	98.43%	98.24%	97.93%	97.33%	H-7	DH3		
3F3Y075K13FCD16	75	200	1880	3.4%	0.67%	1.06%	1.92%	3.04%	97.98%	98.48%	98.60%	98.54%	98.39%	98.26%	97.89%	H-7	DH3		
3F3Y12K13FCD16	112.5	280	2150	3.0%	0.57%	0.93%	1.65%	2.65%	98.13%	98.62%	98.74%	98.71%	98.58%	98.47%	98.16%	H-7	DH4		
3F3Y150K13FCD16	150	350	2610	3.1%	0.53%	0.95%	1.52%	2.71%	98.25%	98.71%	98.83%	98.80%	98.69%	98.30%	98.30%	H-7	DH4		
3F3Y225K13FCD16	225	475	3480	3.2%	0.48%	0.98%	1.39%	2.80%	98.42%	98.94%	98.94%	98.91%	98.81%	98.72%	98.46%	H-7	DH5		
3F3Y300K13FCD16	300	500	5240	4.9%	0.53%	1.37%	1.58%	3.94%	98.68%	98.97%	99.02%	98.94%	98.69%	98.38%	98.38%	H-7	DH5		
3F3Y500K13FCD16	500	750	6200	5.8%	0.45%	1.52%	1.39%	4.40%	98.83%	99.10%	99.14%	99.09%	98.97%	98.88%	98.63%	H-7	DH6		
3F3Y750K13FCD16	750	1010	8470	6.0%	0.42%	1.55%	1.30%	4.48%	98.94%	99.19%	99.23%	99.17%	99.07%	98.98%	98.75%	H-7	TBD		
3F3Y000K13FCD16	1000	1210	10940	5.1%	0.40%	1.34%	1.21%	3.88%	99.04%	99.25%	99.28%	99.22%	99.11%	99.03%	98.80%	H-7	TBD		

K13 208Y/120V Secondary

Temp Rise 80° C

Catalog Number	kVA	No Load Loss Watts	Load Loss Watts	Impedance	Regulation						% Efficiency at different % of rated load							Page Number	Enclosure Type
					at 35% load		at 100% load												
					pf = 1	pf = 0.8	pf = 1	pf = 0.8	15%	25%	35%	50%	65%	75%	100%				
3F3Y015K13BCD16	15	71	375	2.7%	0.81%	0.84%	2.32%	2.39%	96.62%	97.59%	97.89%	97.94%	97.82%	97.69%	97.29%	H-7	DH2		
3F3Y030K13BCD16	30	125	570	2.8%	0.62%	0.92%	1.78%	2.63%	97.05%	97.94%	98.23%	98.32%	98.25%	98.16%	97.87%	H-7	DH2		
3F3Y045K13BCD16	45	158	870	2.6%	0.63%	0.87%	1.81%	2.49%	97.46%	98.18%	98.40%	98.43%	98.32%	98.22%	97.90%	H-7	DH3		
3F3Y075K13BCD16	75	230	1260	2.7%	0.55%	0.88%	1.58%	2.51%	97.77%	98.41%	98.60%	98.63%	98.54%	98.45%	98.17%	H-7	DH3		
3F3Y12K13BCD16	112.5	322	1600	2.8%	0.47%	0.87%	1.35%	2.48%	97.94%	98.55%	98.74%	98.78%	98.71%	98.64%	98.41%	H-7	DH4		
3F3Y150K13BCD16	150	405	1910	2.6%	0.42%	0.80%	1.22%	2.29%	98.06%	98.64%	98.83%	98.88%	98.82%	98.76%	98.56%	H-7	DH4		
3F3Y225K13BCD16	225	465	3350	4.4%	0.50%	1.26%	1.47%	3.63%	98.44%	98.84%	98.94%	98.91%	98.80%	98.70%	98.43%	H-7	DH5		
3F3Y300K13BCD16	300	525	4550	5.5%	0.51%	1.51%	1.55%	4.34%	98.64%	98.96%	99.02%	98.95%	98.83%	98.72%	98.44%	H-7	DH6		
3F3Y500K13BCD16	500	860	5420	5.6%	0.40%	1.46%	1.23%	4.23%	98.71%	99.05%	99.14%	99.12%	99.04%	98.97%	98.76%	H-7	TBD		
3F3Y750K13BCD16	750	1310	6010	5.2%	0.30%	1.30%	0.93%	3.76%	98.73%	99.11%	99.23%	99.26%	99.22%	99.17%	99.03%	H-7	TBD		
3F3Y000K13BCD16	1000	1190	11020	4.7%	0.39%	1.12%	1.18%	3.20%	99.05%	99.25%	99.28%	99.22%	99.11%	99.02%	98.79%	H-7	TBD		

Series H Typical Performance Data

Dry Type 600 Volt Transformers

60 Hz, 10 kv BIL

Aluminum 3-Phase Delta 480V Primary			Temp Rise 150° C										K13 208Y/120V Secondary					
Catalog Number	kVA	No Load Loss Watts	Load Loss Watts	Impedance	Regulation		% Efficiency at different % of rated load										Page Number	Enclosure Type
					at 100% load		15%	25%	35%	50%	65%	75%	100%					
					pf = 1	pf = 0.8	at 35% load	at 100% load	pf = 1	pf = 0.8	at 35% load	at 100% load	pf = 1	pf = 0.8				
3F3Y015K13D16	15	51	669	5.0%	1.19%	1.42%	3.42%	4.06%	97.30%	97.84%	97.89%	97.68%	97.34%	97.09%	96.40%	H-7	DH1	
3F3Y030K13D16	30	90	1060	4.1%	0.95%	1.19%	2.72%	3.39%	97.65%	98.16%	98.23%	98.09%	97.83%	97.64%	97.09%	H-7	DH2	
3F3Y045K13D16	45	120	1440	4.0%	0.86%	1.19%	2.49%	3.41%	97.90%	98.35%	98.40%	98.27%	98.03%	97.85%	97.35%	H-7	DH2	
3F3Y075K13D16	75	190	1930	4.8%	0.71%	1.42%	2.07%	4.06%	98.05%	98.51%	98.60%	98.52%	98.35%	98.20%	97.81%	H-7	DH3	
3F3Y112K13D16	112.5	253	2620	4.3%	0.64%	1.27%	1.88%	3.65%	98.26%	98.74%	98.86%	98.66%	98.50%	98.36%	98.00%	H-7	DH3	
3F3Y150K13D16	150	305	3300	4.6%	0.62%	1.34%	1.81%	3.84%	98.41%	98.77%	98.83%	98.74%	98.58%	98.45%	98.10%	H-7	DH4	
3F3Y225K13D16	225	440	4040	5.0%	0.53%	1.39%	1.58%	4.01%	98.50%	98.86%	98.94%	98.88%	98.76%	98.36%	98.36%	H-7	DH5	
3F3Y300K13D16	300	508	5630	4.6%	0.52%	1.29%	1.55%	3.71%	98.67%	98.97%	99.02%	98.94%	98.81%	98.40%	98.40%	H-7	DH5	
3F3Y500K13D16	500	780	6060	5.3%	0.44%	1.41%	1.34%	4.06%	98.79%	99.08%	99.14%	99.09%	98.98%	98.65%	98.65%	H-7	DH6	
3F3Y750K13D16	750	900	9380	7.5%	0.47%	1.91%	1.52%	5.53%	99.02%	99.21%	99.23%	99.14%	99.01%	98.91%	98.65%	H-7	DH7	
3F3Y000K13D16	1000	1100	11860	6.7%	0.44%	1.72%	1.40%	4.98%	99.10%	99.27%	99.28%	99.19%	99.07%	98.97%	98.72%	H-7	DH8	

Aluminum 3-Phase Delta 480V Primary			Temp Rise 115° C										K13 208Y/120V Secondary					
Catalog Number	kVA	No Load Loss Watts	Load Loss Watts	Impedance	Regulation		% Efficiency at different % of rated load										Page Number	Enclosure Type
					at 100% load		15%	25%	35%	50%	65%	75%	100%					
					pf = 1	pf = 0.8	at 35% load	at 100% load	pf = 1	pf = 0.8	at 35% load	at 100% load	pf = 1	pf = 0.8				
3F3Y015K13FD16	15	58	540	4.5%	1.06%	1.41%	3.04%	4.03%	97.07%	97.76%	97.89%	97.78%	97.52%	97.31%	96.72%	H-7	DH2	
3F3Y030K13FD16	30	106	810	3.6%	0.79%	1.14%	2.29%	3.37%	98.06%	98.23%	98.23%	98.19%	98.03%	97.88%	97.45%	H-7	TBD	
3F3Y045K13FD16	45	137	1150	4.5%	0.76%	1.38%	2.21%	3.96%	97.70%	98.28%	98.40%	98.35%	98.17%	98.02%	97.61%	H-7	TBD	
3F3Y075K13FD16	75	180	1860	5.3%	0.75%	1.57%	2.20%	4.50%	98.12%	98.54%	98.60%	98.50%	98.30%	98.15%	97.72%	H-7	DH3	
3F3Y112K13FD16	112.5	240	2530	4.0%	0.67%	1.23%	1.96%	3.51%	98.32%	98.69%	98.74%	98.64%	98.46%	98.32%	97.93%	H-7	DH4	
3F3Y150K13FD16	150	350	2600	4.4%	0.53%	1.28%	1.57%	3.67%	98.25%	98.71%	98.83%	98.80%	98.69%	98.31%	98.31%	H-7	DH5	
3F3Y225K13FD16	225	440	3930	5.0%	0.53%	1.41%	1.59%	4.05%	98.50%	98.86%	98.94%	98.88%	98.75%	98.65%	98.35%	H-7	DH5	
3F3Y300K13FD16	300	540	4840	6.4%	0.50%	1.69%	1.56%	4.89%	98.62%	98.95%	99.02%	98.97%	98.85%	98.47%	98.47%	H-7	TBD	
3F3Y500K13FD16	500	770	6170	6.1%	0.45%	1.59%	1.41%	4.59%	98.80%	99.08%	99.14%	99.08%	98.97%	98.88%	98.63%	H-7	TBD	
3F3Y750K13FD16	750	995	8610	6.3%	0.42%	1.62%	1.33%	4.68%	98.95%	99.19%	99.23%	99.17%	99.06%	98.74%	98.74%	H-7	TBD	
3F3Y000K13FD16	1000	1100	11880	6.2%	0.44%	1.61%	1.37%	4.66%	99.10%	99.27%	99.28%	99.19%	99.07%	98.97%	98.72%	H-7	TBD	

Aluminum 3-Phase Delta 480V Primary			Temp Rise 80° C										K13 208Y/120V Secondary					
Catalog Number	kVA	No Load Loss Watts	Load Loss Watts	Impedance	Regulation		% Efficiency at different % of rated load										Page Number	Enclosure Type
					at 100% load		15%	25%	35%	50%	65%	75%	100%					
					pf = 1	pf = 0.8	at 35% load	at 100% load	pf = 1	pf = 0.8	at 35% load	at 100% load	pf = 1	pf = 0.8				
3F3Y015K13BD16	15	63	445	3.1%	0.96%	0.98%	2.75%	2.81%	96.89%	97.69%	97.89%	97.84%	97.63%	97.45%	96.94%	H-7	DH2	
3F3Y030K13BD16	30	115	660	3.1%	0.71%	1.03%	2.06%	2.94%	97.22%	98.00%	98.23%	98.25%	98.12%	98.00%	97.64%	H-7	TBD	
3F3Y045K13BD16	45	160	850	4.0%	0.62%	1.22%	1.81%	3.50%	97.44%	98.18%	98.40%	98.44%	98.35%	98.25%	97.94%	H-7	TBD	
3F3Y075K13BD16	75	240	1180	2.9%	0.51%	0.91%	1.48%	2.61%	97.70%	98.38%	98.60%	98.65%	98.58%	98.51%	98.26%	H-7	TBD	
3F3Y112K13BD16	112.5	257	2170	4.1%	0.63%	1.27%	1.85%	3.64%	98.24%	98.66%	98.74%	98.67%	98.51%	98.38%	98.03%	H-7	TBD	
3F3Y150K13BD16	150	406	1880	4.0%	0.41%	1.12%	1.23%	3.21%	98.06%	98.65%	98.83%	98.89%	98.84%	98.78%	98.59%	H-7	TBD	
3F3Y225K13BD16	225	502	2880	3.5%	0.44%	1.02%	1.28%	2.93%	98.36%	98.82%	98.94%	98.95%	98.87%	98.80%	98.57%	H-7	TBD	
3F3Y300K13BD16	300	585	4020	5.8%	0.46%	1.55%	1.41%	4.47%	98.53%	98.92%	99.02%	99.00%	98.90%	98.82%	98.58%	H-7	TBD	
3F3Y500K13BD16	500	860	5440	5.3%	0.40%	1.41%	1.22%	4.06%	98.71%	99.05%	99.14%	99.12%	99.04%	98.76%	98.76%	H-7	TBD	
3F3Y750K13BD16	750	1015	8440	5.6%	0.41%	1.46%	1.27%	4.22%	98.94%	99.18%	99.23%	99.17%	99.07%	98.99%	98.76%	H-7	TBD	
3F3Y000K13BD16	1000	1250	10640	4.4%	0.38%	1.19%	1.15%	3.43%	99.02%	99.24%	99.28%	99.22%	99.12%	98.82%	98.82%	H-7	TBD	

Series H Typical Performance Data

Dry Type 600 Volt Transformers

60 Hz, 10 kv BIL

Harmonic Mitigating Copper 3-Phase Delta 480V Primary				Temp Rise 150° C										K1 208Y/120V Secondary			
Catalog Number	kVA	No Load Loss Watts	Load Loss Watts	Regulation		% Efficiency at different % of rated load										Page Number	
				Impedance	at 35% load	at 100% load	15%	25%	35%	50%	65%	75%	100%	Page Number			
				pf = 1	pf = 0.8	pf = 1	pf = 0.8	pf = 1	pf = 0.8	15%	25%	35%	50%	65%	75%	100%	
3F3Y015CHD1xx	15	73	320	3.00%	0.83%	0.75%	0.83%	2.16%	2.37%	96.56%	97.58%	97.90%	97.99%	97.90%	97.79%	97.43%	8-20
3F3Y030CHD1xx	30	116	590	3.50%	1.05%	0.70%	1.05%	2.01%	3.01%	97.21%	98.00%	98.23%	98.27%	98.15%	98.04%	97.69%	8-20
3F3Y045CHD1xx	45	145	900	3.50%	1.05%	0.71%	1.05%	2.04%	3.01%	97.61%	98.24%	98.40%	98.38%	98.23%	98.10%	97.72%	8-20
3F3Y075CHD1xx	75	195	1460	4.00%	1.29%	0.69%	1.29%	2.00%	3.43%	98.01%	98.50%	98.60%	98.53%	98.36%	98.22%	97.84%	8-20
3F3Y112CHD1xx	112.5	280	1800	4.50%	1.29%	0.58%	1.29%	1.71%	3.71%	98.13%	98.62%	98.74%	98.70%	98.58%	98.47%	98.16%	8-20
3F3Y150CHD1xx	150	330	2400	4.50%	1.29%	0.57%	1.29%	1.68%	3.71%	98.32%	98.74%	98.83%	98.78%	98.64%	98.53%	98.22%	8-20
3F3Y225CHD1xx	225	510	2750	4.00%	1.12%	0.44%	1.12%	1.29%	3.22%	98.33%	98.80%	98.94%	98.95%	98.87%	98.79%	98.57%	8-20
3F3Y300CHD1xx	300	600	3620	5.50%	1.46%	0.44%	1.46%	1.35%	4.20%	98.51%	98.91%	99.02%	99.01%	98.92%	98.84%	98.61%	8-20
3F3Y500CHD1xx	500	1000	4250	5.00%	1.27%	0.31%	1.27%	0.97%	3.67%	98.56%	99.00%	99.14%	99.18%	99.15%	99.10%	98.96%	8-20
3F3Y750CHD1xx	750	1200	6800	6.00%	1.50%	0.34%	1.50%	1.08%	4.35%	98.81%	99.14%	99.23%	99.23%	99.17%	99.11%	98.94%	8-20
3F3Y000CHD1xx	1000	1380	9550	6.00%	1.51%	0.36%	1.51%	1.13%	4.38%	98.95%	99.22%	99.28%	99.25%	99.17%	99.11%	98.92%	8-20

Harmonic Mitigating Aluminum 3-Phase Delta 480V Primary				Temp Rise 150° C										K1 208Y/120V Secondary			
Catalog Number	kVA	No Load Loss Watts	Load Loss Watts	Regulation		% Efficiency at different % of rated load										Page Number	
				Impedance	at 35% load	at 100% load	15%	25%	35%	50%	65%	75%	100%	Page Number			
				pf = 1	pf = 0.8	pf = 1	pf = 0.8	pf = 1	pf = 0.8	15%	25%	35%	50%	65%	75%	100%	
3F3Y015HD1xx	15	68	360	3.70%	1.07%	0.86%	1.07%	2.46%	3.07%	96.72%	97.63%	97.90%	97.92%	97.77%	97.62%	97.19%	8-20
3F3Y030HD1xx	30	96	760	5.50%	1.63%	0.90%	1.63%	2.62%	4.68%	97.55%	98.12%	98.23%	98.13%	97.91%	97.73%	97.23%	8-20
3F3Y045HD1xx	45	134	1000	5.00%	1.46%	0.79%	1.46%	2.31%	4.24%	97.73%	98.28%	98.40%	98.32%	98.13%	97.97%	97.54%	8-20
3F3Y075HD1xx	75	195	1450	5.00%	1.45%	0.69%	1.45%	2.03%	4.16%	98.02%	98.50%	98.60%	98.53%	98.37%	98.23%	97.85%	8-20
3F3Y112HD1xx	112.5	290	1750	4.50%	1.28%	0.55%	1.28%	1.63%	3.68%	98.09%	98.60%	98.74%	98.72%	98.61%	98.51%	98.22%	8-20
3F3Y150HD1xx	150	320	2480	5.00%	1.42%	0.59%	1.42%	1.75%	4.07%	98.36%	98.75%	98.83%	98.76%	98.62%	98.50%	98.17%	8-20
3F3Y225HD1xx	225	500	2800	6.00%	1.58%	0.46%	1.58%	1.43%	4.55%	98.36%	98.81%	98.94%	98.94%	98.85%	98.77%	98.54%	8-20
3F3Y300HD1xx	300	600	3620	6.00%	1.57%	0.44%	1.57%	1.38%	4.53%	98.51%	98.91%	99.02%	99.01%	98.92%	98.84%	98.61%	8-20
3F3Y500HD1xx	500	780	6090	6.50%	1.66%	0.45%	1.66%	1.42%	4.86%	98.79%	99.08%	99.14%	99.09%	98.98%	98.89%	98.64%	8-20
3F3Y750HD1xx	750	1050	8130	6.50%	1.65%	0.40%	1.65%	1.29%	4.78%	98.92%	99.18%	99.23%	99.18%	99.09%	99.01%	98.79%	8-20
3F3Y000HD1xx	1000	1280	10400	6.50%	1.64%	0.39%	1.64%	1.24%	4.76%	99.00%	99.23%	99.28%	99.23%	99.13%	99.06%	98.85%	8-20

© Catalog number will end in 00 for Zero Degree Phase Shift and 30 for 30 Degree Lagging Phase Shift

Series H Typical Performance Data

Efficiency Tables

DOE 2016 Energy Efficient General Purpose Distribution Transformers Aluminum or Copper Windings 80 to 150° C Rise

kVA	Efficiency at 35% of Rated Load, @ 750 C	Impedance	Peak Inrush Current ① Multiple of RMS current
15	97.89%	1.8 to 6%	12 to 15
30	98.23%		
45	98.40%		
75	98.60%	2 to 6%	10 to 12
112.5	98.74%		
150	98.83%		
225	98.94%		
300	99.02%		
500	99.14%	4 to 6%	8 to 10
750	99.23%	4.5 to 6.5%	8 to 10
1000	99.28%		

① The sizing of the overcurrent protection for transformer primaries should be approved by the engineer of record for the panel/location and is based on many factors, including the system coordination required. The minimum breaker size for transformer primaries is typically sized larger than the "practical" maximum inrush calculations by some percentage (usually at least 125% of the "practical" inrush value). "Practical" inrush is typically approximately 1/3 of "Absolute Peak" inrush for calculation purposes. Siemens provides inrush values from our suppliers in charts based on a limited set of catalog numbers. These can be used as a reference, but variations in configurations and the installation environment may result in variations in the actual inrush seen by the system.

DOE 2016 Energy Efficient Harmonic Mitigating Transformers Aluminum or Copper Windings 80 to 150° C Rise

kVA	Efficiency at 35% of Rated Load, @ 750 C	Impedance	Peak Inrush Current ① Multiple of RMS current
15	97.89%	2.5 to 4.5%	12 to 15
30	98.23%	2.5 to 4.5%	12 to 15
45	98.40%	3 to 5%	12 to 15
75	98.60%	3 to 5%	10 to 12
112.5	98.74%	4 to 6%	10 to 12
150	98.83%	4 to 6%	10 to 12
225	98.94%	4 to 6%	10 to 12
300	99.02%	4 to 6%	10 to 12
500	99.14%	4 to 6%	8 to 10
750	99.23%	5 to 7%	8 to 10
1000	99.28%	5 to 7%	8 to 10

① The sizing of the overcurrent protection for transformer primaries must be approved by the engineer of record based on many factors, including the system coordination required and the preferred use of "absolute" or "practical" values for the application. The minimum breaker size for transformer primaries is typically larger than the "practical" maximum inrush amps by some percentage (usually at least 125% of the "practical" inrush value). "Practical" inrush is typically 1/3 of "peak" inrush for calculation purposes.

Notes

Series J Transformers

2016 DOE Compliant

Aluminum K1 3-Phase Delta Primary Series J	J-4 – J-6
Standard Temp Rise – 150° C	J-4
“F” Temp Rise – 115° C	J-5
“B” Temp Rise – 80° C	J-6
Aluminum K4 3-Phase Delta Primary Series J	J-7 – J-9
Standard Temp Rise – 150° C	J-7
“F” Temp Rise – 115° C	J-8
“B” Temp Rise – 80° C	J-9
Aluminum K13 3-Phase Delta Primary Series J	J-10 – J-12
Standard Temp Rise – 150° C	J-10
“F” Temp Rise – 115° C	J-11
“B” Temp Rise – 80° C	J-12
Aluminum K20 3-Phase Delta Primary Series J	J-13 – J-15
Standard Temp Rise – 150° C	J-13
“F” Temp Rise – 115° C	J-14
“B” Temp Rise – 80° C	J-15
Copper K1 3-Phase Delta Primary Series J	J-16 – J-18
Standard Temp Rise – 150° C	J-16
“F” Temp Rise – 115° C	J-17
“B” Temp Rise – 80° C	J-18
Copper K4 3-Phase Delta Primary Series J	J-19 – J-21
Standard Temp Rise – 150° C	J-19
“F” Temp Rise – 115° C	J-20
“B” Temp Rise – 80° C	J-21
Copper K13 3-Phase Delta Primary Series J	J-22 – J-24
Standard Temp Rise – 150° C	J-22
“F” Temp Rise – 115° C	J-23
“B” Temp Rise – 80° C	J-24
Copper K20 3-Phase Delta Primary Series J	J-25 – J-27
Standard Temp Rise – 150° C	J-25
“F” Temp Rise – 115° C	J-26
“B” Temp Rise – 80° C	J-27
T-Wiring Diagrams	J-28 – J-33
Typical Performance Data	J-34 – J-38

Quick Reference for J Series Transformers

Aluminum D16 Drawings and Wiring Diagrams

AL	3 Phase Primary/Secondary	Primary	Secondary	Reference Wiring diagram (Tap = diagram #)	Page Number
AL	3B1	208	240D/120	Y=T208K, M=T208L	J-28/J-29
AL	3B3	208	208Y/120	Y=T208B, M=T208F, N=T208I	J-28
AL	3B5	208	480Y/277	Y=T208D, M=T208G, N=T208J	J-28
AL	3C3	240	208Y/120	Y=T240B, M=T240F, N=T240I	J-29
AL	3C5	240	480Y/277	Y=T240D, M=T240E, N=T240H	J-29
AL	3F1	480	240D/120	Y=T480G, T=T480N	J-30/J-31
AL	3F3	480	208Y/120	Y=T480E, T=T480M	J-30/J-31
AL	3F5	480	480Y/277	Y=T480J, T=T480P	J-31
AL	3F6	480	380Y/219	T=T480K	J-31
AL	3G3	600	208Y/120	T=T600G	J-32
AL	3G5	600	480Y/277	T=T600I	J-33

Aluminum Reference Code / Table Drawing

K-factor	Temp Rise degrees C			Page Numbers
	150 (Std.)	115	80	
Std = K1 K4 K13 K20				
K1	J201	J202	J203	J-4 / J-5 / J-6
K4	J209	J210	J211	J-7 / J-8 / J-9
K13	J212	J213	J228	J-10 / J-11 / J-12
K20	J214	J215	J230	J-13 / J-14 / J-15

Copper D16 Drawings and Wiring Diagrams

CU	3 Phase Primary/Secondary	Primary	Secondary	Reference Wiring diagram (Tap = diagram #)	Page Number
CU	3B1	208	240D/120	Y=T208K, M=T208L	J-28/J-29
CU	3B3	208	208Y/120	Y=T208B, M=T208F, N=T208I	J-28
CU	3B5	208	480Y/277	Y=T208D, M=T208G, N=T208J	J-28
CU	3C3	240	208Y/120	Y=T240B, M=T240F, N=T240I	J-29
CU	3C5	240	480Y/277	Y=T240D, M=T240E, N=T240H	J-29
CU	3F1	480	240D/120	Y=T480G, T=T480N	J-30/J-31
CU	3F3	480	208Y/120	Y=T480E, T=T480M	J-30/J-31
CU	3F5	480	480Y/277	Y=T480J, T=T480P	J-31
CU	3F6	480	380Y/219	T=T480K	J-31
CU	3G3	600	208Y/120	T=T600G	J-32
CU	3G5	600	480Y/277	T=T600I	J-33

Copper Reference Code / Table Drawing

K-factor	Temp Rise degrees C			Page Numbers
	150 (Std.)	115	80	
Std = K1 K4 K13 K20				
K1	J216	J217	J218	J-16 / J-17 / J-18
K4	J221	J222	J223	J-19 / J-20 / J-21
K13	J224	J225	J229	J-22 / J-23 / J-24
K20	J226	J227	J231	J-25 / J-26 / J-27

Impedance Ratings for J Series Transformers

Dry Type 600 Volt Transformers — DOE-2016

60 Hz, 10 kv BIL

Siemens #	KVA	Cond.	Ph.	K	Shield	Temp. Rise	Voltage	Impedance IZ%
3F3Y015D16	15	AL	3	1	NO	150	480D-208Y	4.0
3F3Y030D16	30	AL	3	1	NO	150	480D-208Y	4.3
3F3Y045D16	45	AL	3	1	NO	150	480D-208Y	3.8
3F3Y075D16	75	AL	3	1	NO	150	480D-208Y	4.6
3F3Y112D16	112.5	AL	3	1	NO	150	480D-208Y	6.0
3F3Y150D16	150	AL	3	1	NO	150	480D-208Y	3.8
3F3Y225D16	225	AL	3	1	NO	150	480D-208Y	5.1
3F3Y300D16	300	AL	3	1	NO	150	480D-208Y	6.1
3F3Y500D16	500	AL	3	1	NO	150	480D-208Y	5.3
3F3T750D16	750	AL	3	1	NO	150	480D-208Y	3.7
3F3S000D16	1000	AL	3	1	NO	150	480D-208Y	4.7

Impedance values = +/- 7.5%

Siemens Series J Seismic Installation Guidelines^①

This Seismic Installation Guide is a supplement to the Operation and Installation manual provided with your unit. It does not replace:

- Printed instructions shipped with the equipment.
- Instructions in contract drawings/specifications.
- Required or Industry Code
- Seismic Restraint Device Submittal

Code Qualifications

In order to meet seismic qualifications, rated transformers went through rigorous testing to meet the International Building Code (2015 IBC) and the California Building Code (2016 CBC) requirements. Each test was met in accordance with ICC-ES AC156 seismic qualifications.

Qualified Units

Single & Three-Phase Encapsulated

- Wall mount 1 kVA to 25 kVA
- Floor mount 3 kVA to 75 kVA
- NEMA3R enclosures
- SDS=2.00g ; z/h = 1.00 ; I_p = 1.5

Single-Phase Ventilated

- Floor mount 1 kVA to 250 kVA
- NEMA1 or 3R enclosures
- SDS=2.00g ; z/h = 1.00 ; I_p = 1.5

Three-Phase Ventilated

- Floor mount 1 kVA to 1,000 kVA
- NEMA1 or 3R enclosures
- SDS=1.60g ; z/h = 1.00 ; I_p = 1.5

Totally Enclosed Non Ventilated

- Floor Mount, Single-Phase 1 kVA to 250 kVA
- Floor Mount, Three-Phase 1 kVA to 500 kVA
- NEMA3R Enclosures
- SDS=2.00g ; z/h = 1.00 ; I_p = 1.5

Floor Mount Units

For units up to 300 kVA, use Grade 5 bolts, washers and lock washers to attach the unit to the mounting surface. For units over 300 kVA, use Grade 8 bolts, washers and lock washers. Fill all holes provided in the base.

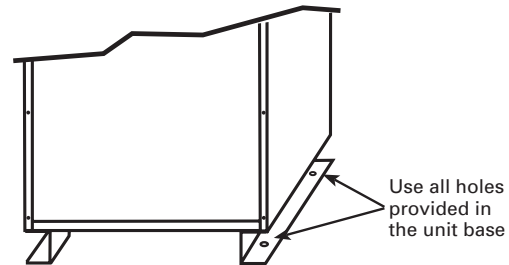

For Wall Mount Units

Install units according to instructions in the Installation Manual. Also use the additional holes provided to add additional stability. Use Grade 5 bolts, washers and lock washers to attach the unit to the mounting surface.

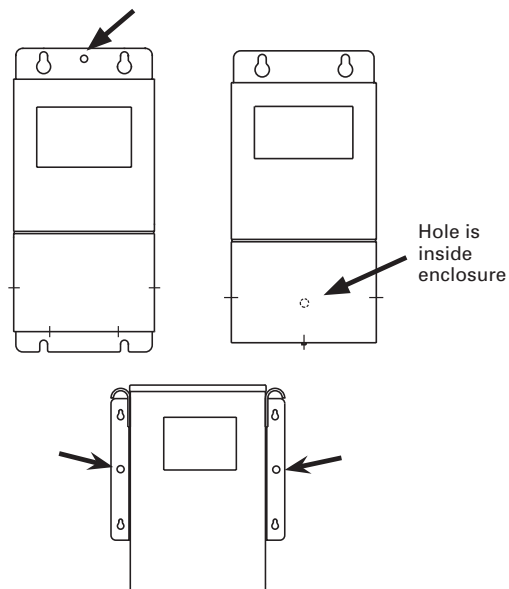

^① These are general guidelines for reference – see Installation instructions shipped with unit for most recent mounting instructions.

Aluminum K1 3-Phase Delta Primary Series J

DOE 2016 3-Phase Dry Type Ventilated Transformer

Standard Temp Rise – 150° C

Reference Siemens Series below:

3BxyyyD16

3CxyyyD16

3FxyyyD16

3GxyyyD16

plus others

SIEMENS DRY TYPE TRANSFORMERS

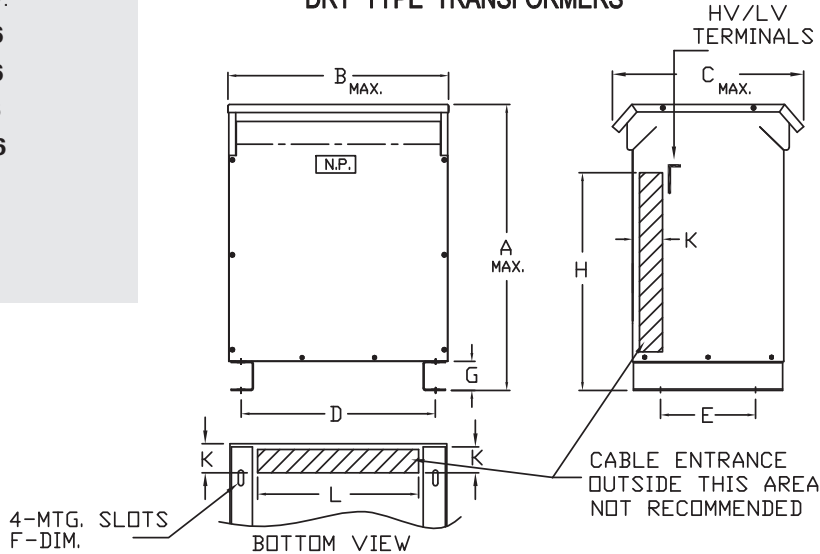

Reference Wiring Diagram Number Below:

T208B	T208D
T208F	T208G
T208I	T208J
T208K	T208L
T240B	T240D
T240E	T240F
T240H	T240I
T480E	T480G
T480J	T480K
T480M	T480N
T480P	T600G
T600I	plus others

TEMP RISE	K-FACTOR	WINDINGS	EFFICIENCY
150	K-1	ALUMINUM	DOE-2016

DIMENSIONS IN (E)=INCHES & (M)=CENTIMETERS

KVA	NET WT. LBS.	A		B		C		D		E		F		G		H		K		L	
		E	M	E	M	E	M	E	M	E	M	E	M	E	M	E	M	E	M	E	M
15	215	22.0	55.9	19.0	48.3	21.0	53.3	16.8	41.6	12.0	30.5	.56x1.13	1.42x2.87	3.0	7.6	12.0	30.5	3.0	7.6	13.0	33.0
30	330	25.0	63.5	22.0	55.9	22.0	55.9	17.4	44.1	13.0	33.0	.56x1.13	1.42x2.87	3.0	7.6	13.0	33.0	3.0	7.6	15.0	38.1
45	415	28.0	71.1	25.0	63.5	23.5	59.7	20.8	52.7	14.5	36.8	.56x1.13	1.42x2.87	3.0	7.6	16.0	40.6	3.0	7.6	17.0	43.2
75	585	32.0	81.3	27.0	68.6	26.0	66.0	23.5	59.7	16.0	40.6	.56x1.13	1.42x2.87	3.0	7.6	18.0	45.7	3.0	7.6	20.0	50.8
112.5	795	38.0	96.5	29.0	73.7	29.0	73.7	25.5	64.8	18.0	45.7	.56x1.13	1.42x2.87	3.0	7.6	20.0	45.8	3.0	7.6	22.0	55.9
150	1035	42.0	107	33.0	83.8	32.5	82.6	29.5	74.9	21.0	53.3	.56x1.13	1.42x2.87	3.0	7.6	23.0	58.4	4.0	10.2	25.5	64.8
225	1430	46.0	117	35.0	88.9	37.0	94.0	31.5	80.0	25.0	63.5	.56x1.13	1.42x2.87	3.0	7.6	32.0	81.3	5.0	12.7	27.5	69.9
300	1755	52.0	132	35.0	88.9	37.0	94.0	31.5	80.0	25.0	63.5	.56x1.13	1.42x2.87	3.0	7.6	32.0	81.3	5.0	12.7	27.5	69.9
500	2760	60.0	154	48.0	122	43.5	110.5	42.0	107	27.0	68.6	.56x1.13	1.42x2.87	4.0	10.2	36.0	91.4	5.0	12.7	34.0	86.4
750	4150	72.0	183	52.0	132	44.0	112	34.0	86.4	42.0	107	.56x1.13	1.42x2.87	4.0	10.2	50.0	112	5.0	12.7	32.0	81.3
1000	6000	81.0	206	66.0	168	61.0	155	63.0	160	38.5	97.8	.56x1.13	1.42x2.87	5.0	12.7	60.0	152	6.0	15.2	48.0	122

NOTES:

- ALL UNITS ARE UL LISTED AND ARE DESIGNED IN ACCORDANCE WITH ANSI C89.2 AND NEMA ST-20 STANDARDS.
- THESE TRANSFORMERS UTILIZE A UL RECOGNIZED 220°C INSULATION SYSTEM.
- TRANSFORMERS ARE DRY TYPE, CLASS AA, VENTILATED ENCLOSURE FOR INDOOR OR OUTDOOR USE.
- FOR LIFTING OTHER THAN WITH FORK TRUCK, REMOVE TOP COVER AND USE CORE CLAMPS.
- PAINT COLOR IS ANSI #61 GRAY.
- FULL WIDTH COPPER ELECTROSTATIC SHIELD (OPTIONAL).
- 6" REQUIRED CLEARANCE FROM THE WALLS.
- HV/LV TERMINALS ARE TOP FRONT TERMINATED.
- NET. WEIGHTS ARE APPROXIMATE.
- MEETS DOE-2016 EFFICIENCY 10 CFR PART 431

Siemens Industry, Inc.

GENERAL PURPOSE TRANSFORMERS
THREE-PHASE, 600 VOLTS CLASS, 60 HZ.

J201

REV.
A

Aluminum K1 3-Phase Delta Primary Series J

DOE 2016 3-Phase Dry Type Ventilated Transformer

"F" Temp Rise – 115° C

Reference Siemens Series below:

3BxxxxxYFD16

3CxxxxxYFD16

3FxxxxxYFD16

3GxxxxxYFD16

plus others

SIEMENS DRY TYPE TRANSFORMERS

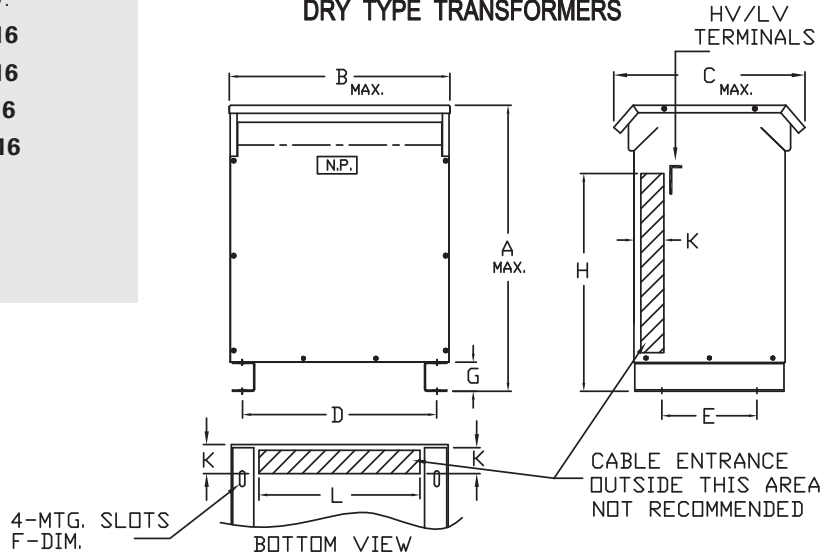

Reference Wiring Diagram Number Below:

T208B	T208D
T208F	T208G
T208I	T208J
T208K	T208L
T240B	T240D
T240E	T240F
T240H	T240I
T480E	T480G
T480J	T480K
T480M	T480N
T480P	T600G
T600I	plus others

TEMP RISE	K-FACTOR	WINDINGS	EFFICIENCY
115	K-1	ALUMINUM	DOE-2016

DIMENSIONS IN (E)=INCHES & (M)=CENTIMETERS

KVA	NET WT. LBS.	A		B		C		D		E		F		G		H		K		L	
		E	M	E	M	E	M	E	M	E	M	E	M	E	M	E	M	E	M	E	M
15	215	22.0	55.9	19.0	48.3	21.0	53.3	16.8	41.6	12.0	30.5	.56x1.13	1.42x2.87	3.0	7.6	12.0	30.5	3.0	7.6	13.0	33.0
30	330	25.0	63.5	22.0	55.9	22.0	55.9	17.4	44.1	13.0	33.0	.56x1.13	1.42x2.87	3.0	7.6	13.0	33.0	3.0	7.6	15.0	38.1
45	415	28.0	71.1	25.0	63.5	23.5	59.7	20.8	52.7	14.5	36.8	.56x1.13	1.42x2.87	3.0	7.6	16.0	40.6	3.0	7.6	17.0	43.2
75	585	32.0	81.3	27.0	68.6	26.0	66.0	23.5	59.7	16.0	40.6	.56x1.13	1.42x2.87	3.0	7.6	18.0	45.7	3.0	7.6	20.0	50.8
112.5	795	38.0	96.5	29.0	73.7	29.0	73.7	25.5	64.8	18.0	45.7	.56x1.13	1.42x2.87	3.0	7.6	20.0	45.8	3.0	7.6	22.0	55.9
150	1035	42.0	107	33.0	83.8	32.5	82.6	29.5	74.9	21.0	53.3	.56x1.13	1.42x2.87	3.0	7.6	23.0	58.4	4.0	10.2	25.5	64.8
225	1430	46.0	117	35.0	88.9	37.0	94.0	31.5	80.0	25.0	63.5	.56x1.13	1.42x2.87	3.0	7.6	32.0	81.3	5.0	12.7	27.5	69.9
300	1755	52.0	132	35.0	88.9	37.0	94.0	31.5	80.0	25.0	63.5	.56x1.13	1.42x2.87	3.0	7.6	32.0	81.3	5.0	12.7	27.5	69.9
500	2760	60.0	154	48.0	122	43.5	110.5	42.0	107	27.0	68.6	.56x1.13	1.42x2.87	4.0	10.2	36.0	91.4	5.0	12.7	34.0	86.4
750	4150	81.0	206	66.0	168	61.0	155	63.0	160	38.5	97.8	.56x1.13	1.42x2.87	5.0	12.7	60.0	152	6.0	15.2	48.0	122
1000		← N/A →																			

NOTES:

- ALL UNITS ARE UL LISTED AND ARE DESIGNED IN ACCORDANCE WITH ANSI C89.2 AND NEMA ST-20 STANDARDS.
- THESE TRANSFORMERS UTILIZE A UL RECOGNIZED 220°C INSULATION SYSTEM.
- TRANSFORMERS ARE DRY TYPE, CLASS AA, VENTILATED ENCLOSURE FOR INDOOR OR OUTDOOR USE.
- FOR LIFTING OTHER THAN WITH FORK TRUCK, REMOVE TOP COVER AND USE CORE CLAMPS.
- PAINT COLOR IS ANSI #61 GRAY.
- FULL WIDTH COPPER ELECTROSTATIC SHIELD (OPTIONAL).
- 6" REQUIRED CLEARANCE FROM THE WALLS.
- HV/LV TERMINALS ARE TOP FRONT TERMINATED.
- NET. WEIGHTS ARE APPROXIMATE.
- MEETS DOE-2016 EFFICIENCY 10 CFR PART 431

Siemens Industry, Inc.

GENERAL PURPOSE TRANSFORMERS
THREE-PHASE, 600 VOLTS CLASS, 60 HZ.

J202

REV. A

Series J Addendum

Aluminum K1 3-Phase Delta Primary Series J

DOE 2016 3-Phase Dry Type Ventilated Transformer

"B" Temp Rise – 80° C

Reference Siemens Series below:

- 3BxyyyBD16**
- 3CxyyyBD16**
- 3FxyyyBD16**
- 3GxyyyBD16**
- plus others

SIEMENS DRY TYPE TRANSFORMERS

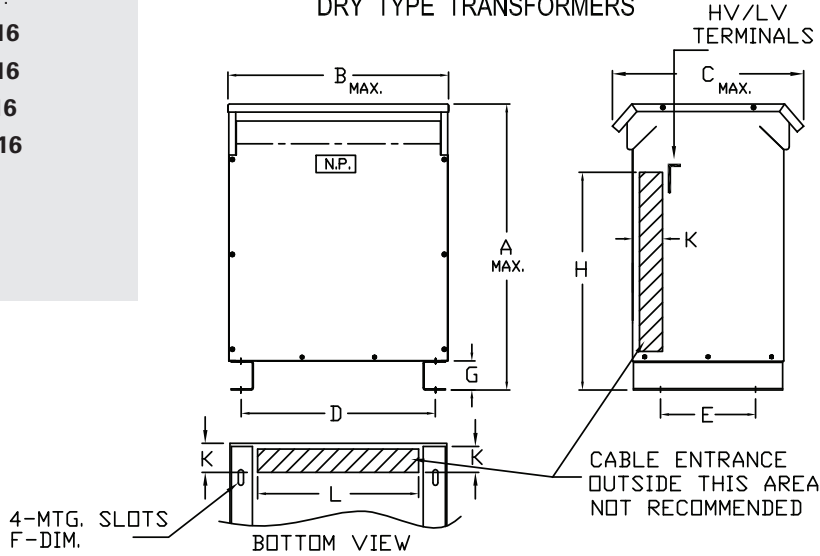

Reference Wiring Diagram Number Below:

T208B	T208D
T208F	T208G
T208I	T208J
T208K	T208L
T240B	T240D
T240E	T240F
T240H	T240I
T480E	T480G
T480J	T480K
T480M	T480N
T480P	T600G
T600I	plus others

TEMP RISE	K-FACTOR	WINDINGS	EFFICIENCY
80	K-1	ALUMINUM	DOE-2016

DIMENSIONS IN (E)=INCHES & (M)=CENTIMETERS

KVA	NET WT. LBS.	A		B		C		D		E		F		G		H		K		L	
		E	M	E	M	E	M	E	M	E	M	E	M	E	M	E	M	E	M	E	M
15	330	25.0	63.5	22.0	55.9	22.0	55.9	17.4	44.2	13.0	33.0	.56x1.13	1.42x2.87	3.0	7.6	13.0	33.0	3.0	7.6	15.0	38.1
30	415	28.0	71.1	25.0	63.5	23.5	59.7	20.8	52.7	14.5	36.8	.56x1.13	1.42x2.87	3.0	7.6	16.0	40.6	3.0	7.6	17.0	43.2
45	585	32.0	81.3	27.0	68.6	26.0	66.0	23.5	59.7	16.0	40.6	.56x1.13	1.42x2.87	3.0	7.6	18.0	45.7	3.0	7.6	20.0	50.8
75	795	38.0	96.5	29.0	73.7	29.0	73.7	25.5	64.8	18.0	45.7	.56x1.13	1.42x2.87	3.0	7.6	20.0	45.8	3.0	7.6	22.0	55.9
112.5	1035	42.0	107	33.0	83.8	32.5	82.6	29.5	74.9	21.0	53.3	.56x1.13	1.42x2.87	3.0	7.6	23.0	58.4	4.0	10.2	25.5	64.8
150	1430	46.0	117	35.0	88.9	37.0	94.0	31.5	80.0	25.0	63.5	.56x1.13	1.42x2.87	3.0	7.6	32.0	81.3	5.0	12.7	27.5	69.9
225	1755	52.0	132	35.0	88.9	37.0	94.0	31.5	80.0	25.0	63.5	.56x1.13	1.42x2.87	3.0	7.6	32.0	81.3	5.0	12.7	27.5	69.9
300	2760	60.0	154	48.0	122	43.5	110.5	42.0	107	27.0	68.6	.56x1.13	1.42x2.87	4.0	10.2	36.0	91.4	5.0	12.7	34.0	86.4
500	4150	72.0	183	52.0	132	44.0	112	34.0	86.4	42.0	107	.56x1.13	1.42x2.87	4.0	10.2	50.0	127	5.0	12.7	32.0	81.3
750		N/A																			
1000		N/A																			

NOTES:

- ALL UNITS ARE UL LISTED AND ARE DESIGNED IN ACCORDANCE WITH ANSI C89.2 AMD NEMA ST-20 STANDARDS.
- THESE TRANSFORMERS UTILIZE A UL RECOGNIZED 220°C INSULATION SYSTEM.
- TRANSFORMERS ARE DRY TYPE, CLASS AA, VENTILATED ENCLOSURE FOR INDOOR OR OUTDOOR USE.
- FOR LIFTING OTHER THAN WITH FORK TRUCK, REMOVE TOP COVER AND USE CORE CLAMPS.
- PAINT COLOR IS ANSI #61 GRAY.
- FULL WIDTH COPPER ELECTROSTATIC SHIELD (OPTIONAL).
- 6" REQUIRED CLEARANCE FROM THE WALLS.
- HV/LV TERMINALS ARE TOP FRONT TERMINATED.
- NET. WEIGHTS ARE APPROXIMATE.
- MEETS DOE-2016 EFFICIENCY 10 CFR PART 431

Siemens Industry, Inc.

GENERAL PURPOSE TRANSFORMERS
THREE-PHASE, 600 VOLTS CLASS, 60 HZ.

J203

REV.
A

Aluminum K4 3-Phase Delta Primary Series J

DOE 2016 3-Phase Dry Type Ventilated Transformer

Standard Temp Rise – 150° C

Reference Siemens Series below:

- 3BxxxxxK4D16**
- 3CxxxxxK4D16**
- 3FxxxxxK4D16**
- 3GxxxxxK4D16**
- plus others

SIEMENS DRY TYPE TRANSFORMERS

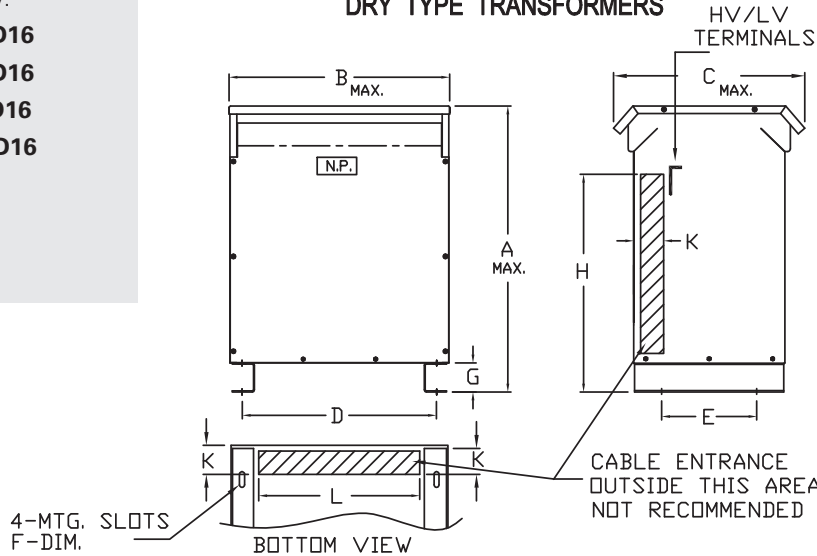

Reference Wiring Diagram Number Below:

T208B	T208D
T208F	T208G
T208I	T208J
T208K	T208L
T240B	T240D
T240E	T240F
T240H	T240I
T480E	T480G
T480J	T480K
T480M	T480N
T480P	T600G
T600I	plus others

TEMP RISE	K-FACTOR	WINDINGS	EFFICIENCY
150	K-4	ALUMINUM	DOE-2016

DIMENSIONS IN (E)=INCHES & (M)=CENTIMETERS

KVA	NET WT. LBS.	A		B		C		D		E		F		G		H		K		L	
		E	M	E	M	E	M	E	M	E	M	E	M	E	M	E	M	E	M	E	M
15	215	22.0	55.9	19.0	48.3	21.0	53.3	16.8	41.6	12.0	30.5	.56x1.13	1.42x2.87	3.0	7.6	12.0	30.5	3.0	7.6	13.0	33.0
30	330	25.0	63.5	22.0	55.9	22.0	55.9	17.4	44.1	13.0	33.0	.56x1.13	1.42x2.87	3.0	7.6	13.0	33.0	3.0	7.6	15.0	38.1
45	415	28.0	71.1	25.0	63.5	23.5	59.7	20.8	52.7	14.5	36.8	.56x1.13	1.42x2.87	3.0	7.6	16.0	40.6	3.0	7.6	17.0	43.2
75	585	32.0	81.3	27.0	68.6	26.0	66.0	23.5	59.7	16.0	40.6	.56x1.13	1.42x2.87	3.0	7.6	18.0	45.7	3.0	7.6	20.0	50.8
112.5	795	38.0	96.5	29.0	73.7	29.0	73.7	25.5	64.8	18.0	45.7	.56x1.13	1.42x2.87	3.0	7.6	20.0	45.8	3.0	7.6	22.0	55.9
150	1035	42.0	107	33.0	83.8	32.5	82.6	29.5	74.9	21.0	53.3	.56x1.13	1.42x2.87	3.0	7.6	23.0	58.4	4.0	10.2	25.5	64.8
225	1430	46.0	117	35.0	88.9	37.0	94.0	31.5	80.0	25.0	63.5	.56x1.13	1.42x2.87	3.0	7.6	32.0	81.3	5.0	12.7	27.5	69.9
300	1755	52.0	132	35.0	88.9	37.0	94.0	31.5	80.0	25.0	63.5	.56x1.13	1.42x2.87	3.0	7.6	32.0	81.3	5.0	12.7	27.5	69.9
500	2760	60.0	154	48.0	122	43.5	110.5	42.0	107	27.0	68.6	.56x1.13	1.42x2.87	4.0	10.2	36.0	91.4	5.0	12.7	34.0	86.4
750	4150	72.0	183	52.0	132	44.0	112	34.0	86.4	42.0	107	.56x1.13	1.42x2.87	4.0	10.2	50.0	127	5.0	12.7	32.0	81.3
1000		N/A																			

NOTES:

- ALL UNITS ARE UL LISTED AND ARE DESIGNED IN ACCORDANCE WITH ANSI C89.2 AMD NEMA ST-20 STANDARDS.
- THESE TRANSFORMERS UTILIZE A UL RECOGNIZED 220°C INSULATION SYSTEM.
- TRANSFORMERS ARE DRY TYPE, CLASS AA, VENTILATED ENCLOSURE FOR INDOOR OR OUTDOOR USE.
- FOR LIFTING OTHER THAN WITH FORK TRUCK, REMOVE TOP COVER AND USE CORE CLAMPS.
- PAINT COLOR IS ANSI #61 GRAY.
- FULL WIDTH COPPER ELECTROSTATIC SHIELD.
- 6" REQUIRED CLEARANCE FROM THE WALLS.
- HV/LV TERMINALS ARE TOP FRONT TERMINATED.
- NET. WEIGHTS ARE APPROXIMATE.
- MEETS DOE-2016 EFFICIENCY 10 CFR PART 431

Siemens Industry, Inc.

GENERAL PURPOSE TRANSFORMERS
THREE-PHASE, 600 VOLTS CLASS, 60 HZ.

J209

REV. B

Series J Addendum

Aluminum K4 3-Phase Delta Primary Series J

DOE 2016 3-Phase Dry Type Ventilated Transformer

"F" Temp Rise – 115° C

Reference Siemens Series below:

- 3BxyyyK4FD16**
- 3CxyyyK4FD16**
- 3FxyyyK4FD16**
- 3GxyyyK4FD16**
- plus others

SIEMENS DRY TYPE TRANSFORMERS

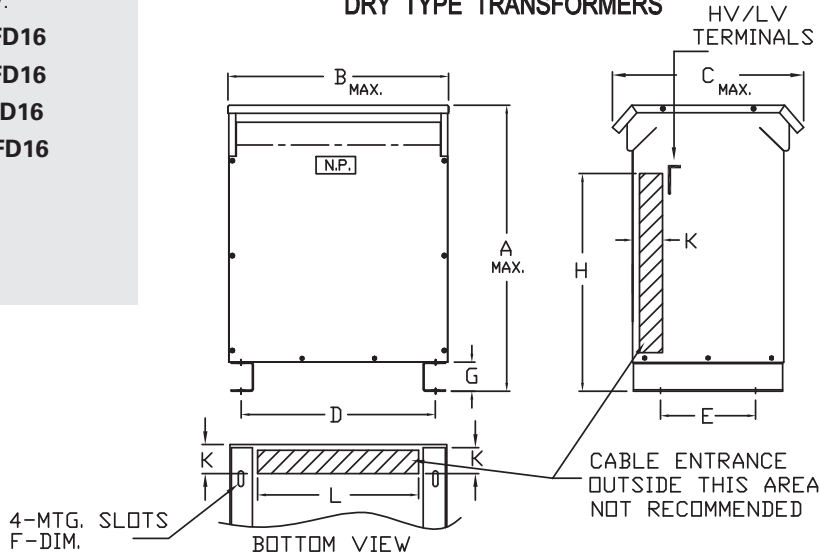

Reference Wiring Diagram Number Below:

T208B	T208D
T208F	T208G
T208I	T208J
T208K	T208L
T240B	T240D
T240E	T240F
T240H	T240I
T480E	T480G
T480J	T480K
T480M	T480N
T480P	T600G
T600I	plus others

TEMP RISE	K-FACTOR	WINDINGS	EFFICIENCY
115	K-4	ALUMINUM	DOE-2016

DIMENSIONS IN (E)=INCHES & (M)=CENTIMETERS

KVA	NET WT. LBS.	A		B		C		D		E		F		G		H		K		L	
		E	M	E	M	E	M	E	M	E	M	E	M	E	M	E	M	E	M	E	M
15	215	22.0	55.9	19.0	48.3	21.0	53.3	16.8	41.6	12.0	30.5	.56x1.13	1.42x2.87	3.0	7.6	12.0	30.5	3.0	7.6	13.0	33.0
30	330	25.0	63.5	22.0	55.9	22.0	55.9	17.4	44.1	13.0	33.0	.56x1.13	1.42x2.87	3.0	7.6	13.0	33.0	3.0	7.6	15.0	38.1
45	415	28.0	71.1	25.0	63.5	23.5	59.7	20.8	52.7	14.5	36.8	.56x1.13	1.42x2.87	3.0	7.6	16.0	40.6	3.0	7.6	17.0	43.2
75	585	32.0	81.3	27.0	68.6	26.0	66.0	23.5	59.7	16.0	40.6	.56x1.13	1.42x2.87	3.0	7.6	18.0	45.7	3.0	7.6	20.0	50.8
112.5	795	38.0	96.5	29.0	73.7	29.0	73.7	25.5	64.8	18.0	45.7	.56x1.13	1.42x2.87	3.0	7.6	20.0	45.8	3.0	7.6	22.0	55.9
150	1035	42.0	107	33.0	83.8	32.5	82.6	29.5	74.9	21.0	53.3	.56x1.13	1.42x2.87	3.0	7.6	23.0	58.4	4.0	10.2	25.5	64.8
225	1430	46.0	117	35.0	88.9	37.0	94.0	31.5	80.0	25.0	63.5	.56x1.13	1.42x2.87	3.0	7.6	32.0	81.3	5.0	12.7	27.5	69.9
300	1755	52.0	132	35.0	88.9	37.0	94.0	31.5	80.0	25.0	63.5	.56x1.13	1.42x2.87	3.0	7.6	32.0	81.3	5.0	12.7	27.5	69.9
500	2760	60.0	154	48.0	122	43.5	110.5	42.0	107	27.0	68.6	.56x1.13	1.42x2.87	4.0	10.2	36.0	91.4	5.0	12.7	34.0	86.4
750	4150	72.0	183	52.0	132	44.0	112	34.0	86.4	42.0	107	.56x1.13	1.42x2.87	4.0	10.2	50.0	112	5.0	12.7	32.0	81.3
1000	6000	81.0	206	66.0	168	61.0	155	63.0	160	38.5	97.8	.56x1.13	1.42x2.87	5.0	12.7	60.0	152	6.0	15.2	48.0	122

NOTES:

- ALL UNITS ARE UL LISTED AND ARE DESIGNED IN ACCORDANCE WITH ANSI C89.2 AND NEMA ST-20 STANDARDS.
- THESE TRANSFORMERS UTILIZE A UL RECOGNIZED 220°C INSULATION SYSTEM.
- TRANSFORMERS ARE DRY TYPE, CLASS AA, VENTILATED ENCLOSURE FOR INDOOR OR OUTDOOR USE.
- FOR LIFTING OTHER THAN WITH FORK TRUCK, REMOVE TOP COVER AND USE CORE CLAMPS.
- PAINT COLOR IS ANSI #61 GRAY.
- FULL WIDTH COPPER ELECTROSTATIC SHIELD.
- 6" REQUIRED CLEARANCE FROM THE WALLS.
- HV/LV TERMINALS ARE TOP FRONT TERMINATED.
- NET. WEIGHTS ARE APPROXIMATE.
- MEETS DOE-2016 EFFICIENCY 10 CFR PART 431

Siemens Industry, Inc.

GENERAL PURPOSE TRANSFORMERS
THREE-PHASE, 600 VOLTS CLASS, 60 HZ.

J210

REV. B

Aluminum K4 3-Phase Delta Primary Series J

DOE 2016 3-Phase Dry Type Ventilated Transformer

"B" Temp Rise – 80° C

Reference Siemens Series below:

- 3BxxxxxK4BD16**
- 3CxxxxxK4BD16**
- 3FxxxxxK4BD16**
- 3GxxxxxK4BD16**
- plus others

SIEMENS DRY TYPE TRANSFORMERS

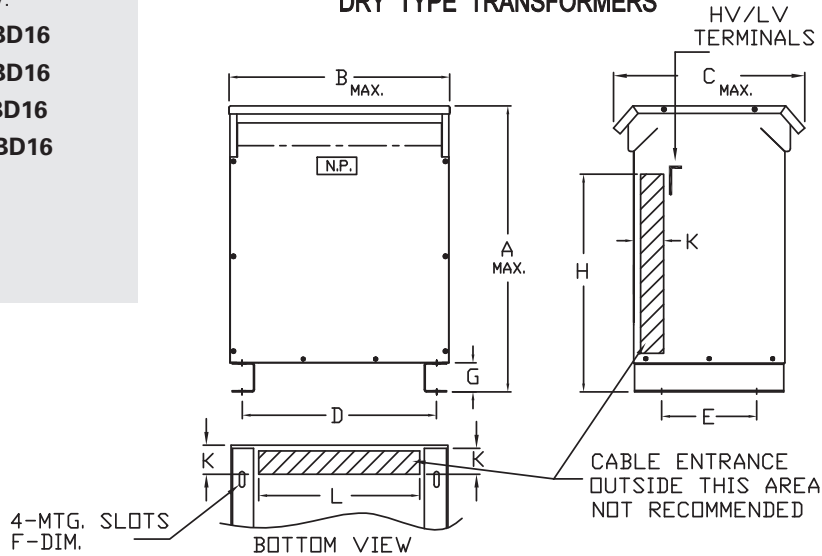

Reference Wiring Diagram Number Below:

T208B	T208D
T208F	T208G
T208I	T208J
T208K	T208L
T240B	T240D
T240E	T240F
T240H	T240I
T480E	T480G
T480J	T480K
T480M	T480N
T480P	T600G
T600I	plus others

TEMP RISE	K-FACTOR	WINDINGS	EFFICIENCY
80	K-4	ALUMINUM	DOE-2016

DIMENSIONS IN (E)=INCHES & (M)=CENTIMETERS

KVA	NET WT. LBS.	A		B		C		D		E		F		G		H		K		L	
		E	M	E	M	E	M	E	M	E	M	E	M	E	M	E	M	E	M	E	M
15	310	25.0	63.5	22.0	55.9	22.0	55.9	17.4	44.2	13.0	33.0	.56x1.13	1.42x2.87	3.0	7.6	13.0	33.0	3.0	7.6	15.0	38.1
30	400	28.0	71.1	25.0	63.5	23.5	59.7	20.8	52.7	14.5	36.8	.56x1.13	1.42x2.87	3.0	7.6	16.0	40.6	3.0	7.6	17.0	43.2
45	585	32.0	81.3	27.0	68.6	26.0	66.0	23.5	59.7	16.0	40.6	.56x1.13	1.42x2.87	3.0	7.6	18.0	45.7	3.0	7.6	20.0	50.8
75	775	38.0	96.5	29.0	73.7	29.0	73.7	25.5	64.8	18.0	45.7	.56x1.13	1.42x2.87	3.0	7.6	20.0	45.8	3.0	7.6	22.0	55.9
112.5	1000	42.0	107	33.0	83.8	32.5	82.6	29.5	74.9	21.0	53.3	.56x1.13	1.42x2.87	3.0	7.6	23.0	58.4	4.0	10.2	25.5	64.8
150	1315	46.0	117	35.0	88.9	37.0	94.0	31.5	80.0	25.0	63.5	.56x1.13	1.42x2.87	3.0	7.6	32.0	81.3	5.0	12.7	27.5	69.9
225	1665	52.0	132	35.0	88.9	37.0	94.0	31.5	80.0	25.0	63.5	.56x1.13	1.42x2.87	3.0	7.6	32.0	81.3	5.0	12.7	27.5	69.9
300	2460	60.0	154	48.0	122	43.5	110.5	42.0	107	27.0	68.6	.56x1.13	1.42x2.87	4.0	10.2	36.0	91.4	5.0	12.7	34.0	86.4
500	4300	72.0	183	52.0	132	44.0	112	34.0	86.4	42.0	107	.56x1.13	1.42x2.87	4.0	10.2	50.0	127	5.0	12.7	32.0	81.3
750		N/A																			
1000		N/A																			

NOTES:

- ALL UNITS ARE UL LISTED AND ARE DESIGNED IN ACCORDANCE WITH ANSI C89.2 AMD NEMA ST-20 STANDARDS.
- THESE TRANSFORMERS UTILIZE A UL RECOGNIZED 220°C INSULATION SYSTEM.
- TRANSFORMERS ARE DRY TYPE, CLASS AA, VENTILATED ENCLOSURE FOR INDOOR OR OUTDOOR USE.
- FOR LIFTING OTHER THAN WITH FORK TRUCK, REMOVE TOP COVER AND USE CORE CLAMPS.
- PAINT COLOR IS ANSI #61 GRAY.
- FULL WIDTH COPPER ELECTROSTATIC SHIELD.
- 6" REQUIRED CLEARANCE FROM THE WALLS.
- HV/LV TERMINALS ARE TOP FRONT TERMINATED.
- NET. WEIGHTS ARE APPROXIMATE.
- MEETS DOE-2016 EFFICIENCY 10 CFR PART 431

Siemens Industry, Inc.

GENERAL PURPOSE TRANSFORMERS
THREE-PHASE, 600 VOLTS CLASS, 60 HZ.

J211

REV.
B

Aluminum K13 3-Phase Delta Primary Series J

DOE 2016 3-Phase Dry Type Ventilated Transformer

Standard Temp Rise – 150° C

Reference Siemens Series below:

- 3BxyyyK13D16**
- 3CxyyyK13D16**
- 3FxyyyK13D16**
- 3GxyyyK13D16**
- plus others

SIEMENS DRY TYPE TRANSFORMERS

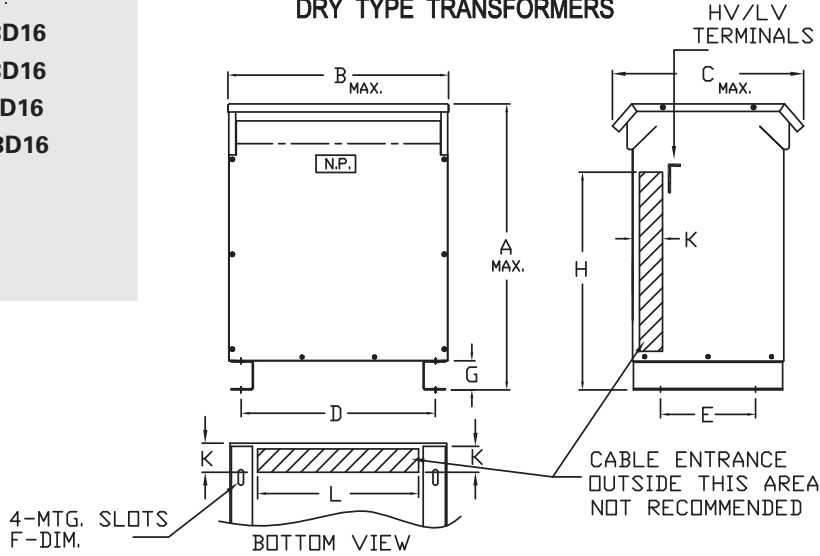

Reference Wiring Diagram Number Below:

T208B	T208D
T208F	T208G
T208I	T208J
T208K	T208L
T240B	T240D
T240E	T240F
T240H	T240I
T480E	T480G
T480J	T480K
T480M	T480N
T480P	T600G
T600I	plus others

TEMP RISE	K-FACTOR	WINDINGS	EFFICIENCY
150	K-13	ALUMINUM	DOE-2016

DIMENSIONS IN (E)=INCHES & (M)=CENTIMETERS

KVA	NET WT. LBS.	A		B		C		D		E		F		G		H		K		L	
		E	M	E	M	E	M	E	M	E	M	E	M	E	M	E	M	E	M	E	M
15	330	25.0	63.5	22.0	55.9	22.0	55.9	17.4	44.2	13.0	33.0	.56x1.13	1.42x2.87	3.0	7.6	13.0	33.0	3.0	7.6	15.0	38.1
30	415	28.0	71.1	25.0	63.5	23.5	59.7	20.8	52.7	14.5	36.8	.56x1.13	1.42x2.87	3.0	7.6	16.0	40.6	3.0	7.6	17.0	43.2
45	585	32.0	81.3	27.0	68.6	26.0	66.0	23.5	59.7	16.0	40.6	.56x1.13	1.42x2.87	3.0	7.6	18.0	45.7	3.0	7.6	20.0	50.8
75	795	38.0	96.5	29.0	73.7	29.0	73.7	25.5	64.8	18.0	45.7	.56x1.13	1.42x2.87	3.0	7.6	20.0	45.8	3.0	7.6	22.0	55.9
112.5	1035	42.0	107	33.0	83.8	32.5	82.6	29.5	74.9	21.0	53.3	.56x1.13	1.42x2.87	3.0	7.6	23.0	58.4	4.0	10.2	25.5	64.8
150	1430	46.0	117	35.0	88.9	37.0	94.0	31.5	80.0	25.0	63.5	.56x1.13	1.42x2.87	3.0	7.6	32.0	81.3	5.0	12.7	27.5	69.9
225	1755	52.0	132	35.0	88.9	37.0	94.0	31.5	80.0	25.0	63.5	.56x1.13	1.42x2.87	3.0	7.6	32.0	81.3	5.0	12.7	27.5	69.9
300	2760	60.0	154	48.0	122	43.5	110.5	42.0	107	27.0	68.6	.56x1.13	1.42x2.87	4.0	10.2	36.0	91.4	5.0	12.7	34.0	86.4
500	4150	72.0	183	52.0	132	44.0	112	34.0	86.4	42.0	107	.56x1.13	1.42x2.87	4.0	10.2	50.0	127	5.0	12.7	32.0	81.3
750		N/A																			
1000		N/A																			

NOTES:

- ALL UNITS ARE UL LISTED AND ARE DESIGNED IN ACCORDANCE WITH ANSI C89.2 AMD NEMA ST-20 STANDARDS.
- THESE TRANSFORMERS UTILIZE A UL RECOGNIZED 220°C INSULATION SYSTEM.
- TRANSFORMERS ARE DRY TYPE, CLASS AA, VENTILATED ENCLOSURE FOR INDOOR OR OUTDOOR USE.
- FOR LIFTING OTHER THAN WITH FORK TRUCK, REMOVE TOP COVER AND USE CORE CLAMPS.
- PAINT COLOR IS ANSI #61 GRAY.
- FULL WIDTH COPPER ELECTROSTATIC SHIELD.
- 6" REQUIRED CLEARANCE FROM THE WALLS.
- HV/LV TERMINALS ARE TOP FRONT TERMINATED.
- NET. WEIGHTS ARE APPROXIMATE.
- MEETS DOE-2016 EFFICIENCY 10 CFR PART 431

Siemens Industry, Inc.

GENERAL PURPOSE TRANSFORMERS
THREE-PHASE, 600 VOLTS CLASS, 60 HZ.

J212

REV. B

Aluminum K13 3-Phase Delta Primary Series J

DOE 2016 3-Phase Dry Type Ventilated Transformer

"F" Temp Rise – 115° C

Reference Siemens Series below:

3BxxxxxK13FD16

3CxxxxxK13FD16

3FxxxxxK13FD16

3GxxxxxK13FD16

plus others

SIEMENS DRY TYPE TRANSFORMERS

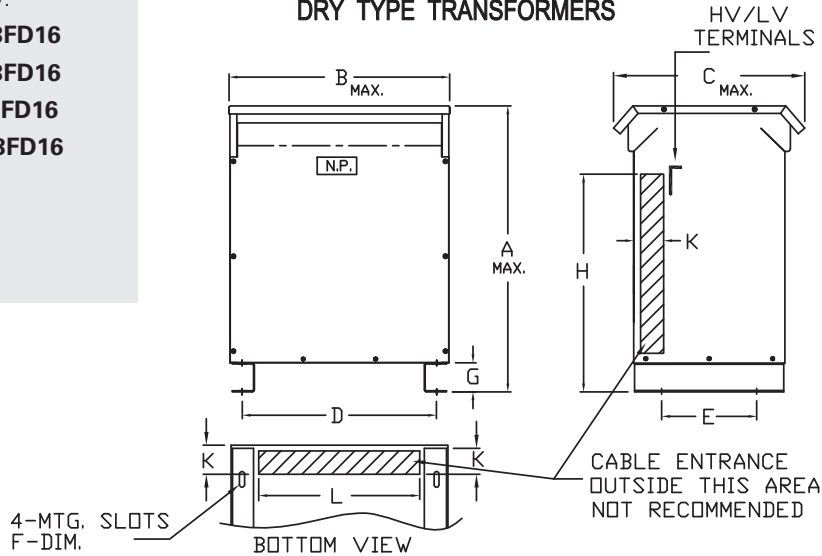

Reference Wiring Diagram Number Below:

T208B	T208D
T208F	T208G
T208I	T208J
T208K	T208L
T240B	T240D
T240E	T240F
T240H	T240I
T480E	T480G
T480J	T480K
T480M	T480N
T480P	T600G
T600I	plus others

TEMP RISE	K-FACTOR	WINDINGS	EFFICIENCY
115	K-13	ALUMINUM	DOE-2016

DIMENSIONS IN (E)=INCHES & (M)=CENTIMETERS

KVA	NET WT. LBS.	A		B		C		D		E		F		G		H		K		L	
		E	M	E	M	E	M	E	M	E	M	E	M	E	M	E	M	E	M	E	M
15	330	25.0	63.5	22.0	55.9	22.0	55.9	17.4	44.2	13.0	33.0	.56x1.13	1.42x2.87	3.0	7.6	13.0	33.0	3.0	7.6	15.0	38.1
30	415	28.0	71.1	25.0	63.5	23.5	59.7	20.8	52.7	14.5	36.8	.56x1.13	1.42x2.87	3.0	7.6	16.0	40.6	3.0	7.6	17.0	43.2
45	585	32.0	81.3	27.0	68.6	26.0	66.0	23.5	59.7	16.0	40.6	.56x1.13	1.42x2.87	3.0	7.6	18.0	45.7	3.0	7.6	20.0	50.8
75	795	38.0	96.5	29.0	73.7	29.0	73.7	25.5	64.8	18.0	45.7	.56x1.13	1.42x2.87	3.0	7.6	20.0	45.8	3.0	7.6	22.0	55.9
112.5	1035	42.0	107	33.0	83.8	32.5	82.6	29.5	74.9	21.0	53.3	.56x1.13	1.42x2.87	3.0	7.6	23.0	58.4	4.0	10.2	25.5	64.8
150	1430	46.0	117	35.0	88.9	37.0	94.0	31.5	80.0	25.0	63.5	.56x1.13	1.42x2.87	3.0	7.6	32.0	81.3	5.0	12.7	27.5	69.9
225	1755	52.0	132	35.0	88.9	37.0	94.0	31.5	80.0	25.0	63.5	.56x1.13	1.42x2.87	3.0	7.6	32.0	81.3	5.0	12.7	27.5	69.9
300	2760	60.0	154	48.0	122	43.5	110.5	42.0	107	27.0	68.6	.56x1.13	1.42x2.87	4.0	10.2	36.0	91.4	5.0	12.7	34.0	86.4
500	4150	72.0	183	52.0	132	44.0	112	34.0	86.4	42.0	107	.56x1.13	1.42x2.87	4.0	10.2	50.0	127	5.0	12.7	32.0	81.3
750		N/A																			
1000		N/A																			

NOTES:

- ALL UNITS ARE UL LISTED AND ARE DESIGNED IN ACCORDANCE WITH ANSI C89.2 AMD NEMA ST-20 STANDARDS.
- THESE TRANSFORMERS UTILIZE A UL RECOGNIZED 220°C INSULATION SYSTEM.
- TRANSFORMERS ARE DRY TYPE, CLASS AA, VENTILATED ENCLOSURE FOR INDOOR OR OUTDOOR USE.
- FOR LIFTING OTHER THAN WITH FORK TRUCK, REMOVE TOP COVER AND USE CORE CLAMPS.
- PAINT COLOR IS ANSI #61 GRAY.
- FULL WIDTH COPPER ELECTROSTATIC SHIELD.
- 6" REQUIRED CLEARANCE FROM THE WALLS.
- HV/LV TERMINALS ARE TOP FRONT TERMINATED.
- NET. WEIGHTS ARE APPROXIMATE.
- MEETS DOE-2016 EFFICIENCY 10 CFR PART 431

Siemens Industry, Inc.

GENERAL PURPOSE TRANSFORMERS
THREE-PHASE, 600 VOLTS CLASS, 60 HZ.

J213

REV. B

Aluminum K13 3-Phase Delta Primary Series J

DOE 2016 3-Phase Dry Type Ventilated Transformer

"B" Temp Rise – 80° C

Reference Siemens Series below:

- 3BxyyyK13BD16**
- 3CxyyyK13BD16**
- 3FxyyyK13BD16**
- 3GxyyyK13BD16**
- plus others

SIEMENS DRY TYPE TRANSFORMERS

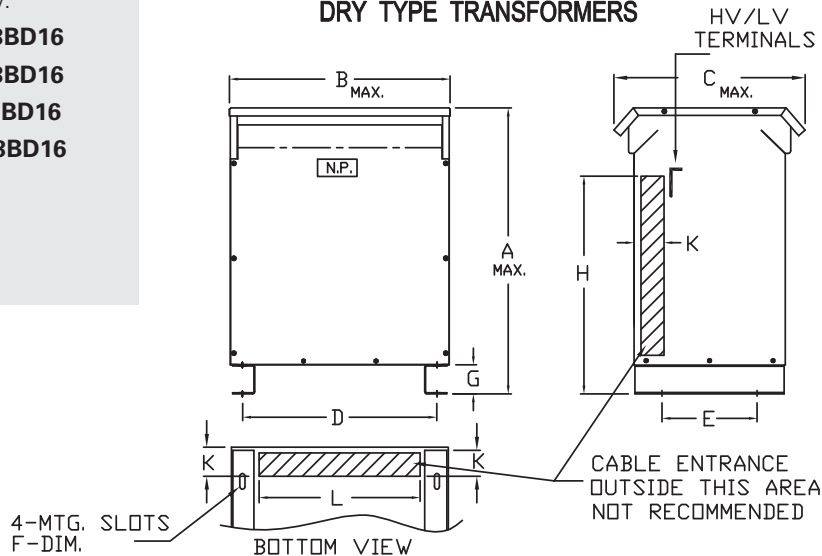

Reference Wiring Diagram Number Below:

T208B	T208D
T208F	T208G
T208I	T208J
T208K	T208L
T240B	T240D
T240E	T240F
T240H	T240I
T480E	T480G
T480J	T480K
T480M	T480N
T480P	T600G
T600I	plus others

TEMP RISE	K-FACTOR	WINDINGS	EFFICIENCY
80	K13	ALUMINUM	DOE-2016

DIMENSIONS IN (E)=INCHES & (M)=CENTIMETERS

KVA	NET WT. LBS.	A		B		C		D		E		F		G		H		K		L	
		E	M	E	M	E	M	E	M	E	M	E	M	E	M	E	M	E	M	E	M
15	310	25.0	63.5	22.0	55.9	22.0	55.9	17.4	44.1	13.0	33.0	.56x1.13	1.42x2.87	3.0	7.6	13.0	33.0	3.0	7.6	15.0	38.1
30	400	28.0	71.1	25.0	63.5	23.5	59.7	20.8	52.7	14.5	36.8	.56x1.13	1.42x2.87	3.0	7.6	16.0	40.6	3.0	7.6	17.0	43.2
45	585	32.0	81.3	27.0	68.6	26.0	66.0	23.5	59.7	16.0	40.6	.56x1.13	1.42x2.87	3.0	7.6	18.0	45.7	3.0	7.6	20.0	50.8
75	775	38.0	96.5	29.0	73.7	29.0	73.7	25.5	64.8	18.0	45.7	.56x1.13	1.42x2.87	3.0	7.6	20.0	45.8	3.0	7.6	22.0	55.9
112.5	1000	42.0	107	33.0	83.8	32.5	82.6	29.5	74.9	21.0	53.3	.56x1.13	1.42x2.87	3.0	7.6	23.0	58.4	4.0	10.2	25.5	64.8
150	1315	46.0	117	35.0	88.9	37.0	94.0	31.5	80.0	25.0	63.5	.56x1.13	1.42x2.87	3.0	7.6	32.0	81.3	5.0	12.7	27.5	69.9
225	1665	52.0	132	35.0	88.9	37.0	94.0	31.5	80.0	25.0	63.5	.56x1.13	1.42x2.87	3.0	7.6	32.0	81.3	5.0	12.7	27.5	69.9
300	2460	60.0	154	48.0	122	43.5	110.5	42.0	107	27.0	68.6	.56x1.13	1.42x2.87	4.0	10.2	36.0	91.4	5.0	12.7	34.0	86.4
500	4300	72.0	183	52.0	132	44.0	112	34.0	86.4	42.0	107	.56x1.13	1.42x2.87	4.0	10.2	50.0	112	5.0	12.7	32.0	81.3
750		N/A																			
1000		N/A																			

NOTES:

- ALL UNITS ARE UL LISTED AND ARE DESIGNED IN ACCORDANCE WITH ANSI C89.2 AMD NEMA ST-20 STANDARDS.
- THESE TRANSFORMERS UTILIZE A UL RECOGNIZED 220°C INSULATION SYSTEM.
- TRANSFORMERS ARE DRY TYPE, CLASS AA, VENTILATED ENCLOSURE FOR INDOOR OR OUTDOOR USE.
- FOR LIFTING OTHER THAN WITH FORK TRUCK, REMOVE TOP COVER AND USE CORE CLAMPS.
- PAINT COLOR IS ANSI #61 GRAY.
- FULL WIDTH COPPER ELECTROSTATIC SHIELD.
- 6" REQUIRED CLEARANCE FROM THE WALLS.
- HV/LV TERMINALS ARE TOP FRONT TERMINATED.
- NET. WEIGHTS ARE APPROXIMATE.
- MEETS DOE-2016 EFFICIENCY 10 CFR PART 431

Siemens Industry, Inc.

GENERAL PURPOSE TRANSFORMERS
THREE-PHASE, 600 VOLTS CLASS, 60 HZ.

J228

REV.
B

Aluminum K20 3-Phase Delta Primary Series J

DOE 2016 3-Phase Dry Type Ventilated Transformer

Standard Temp Rise – 150° C

Reference Siemens Series below:

- 3BxxxxxK20D16**
- 3CxxxxxK20D16**
- 3FxxxxxK20D16**
- 3GxxxxxK20D16**
- plus others

SIEMENS DRY TYPE TRANSFORMERS

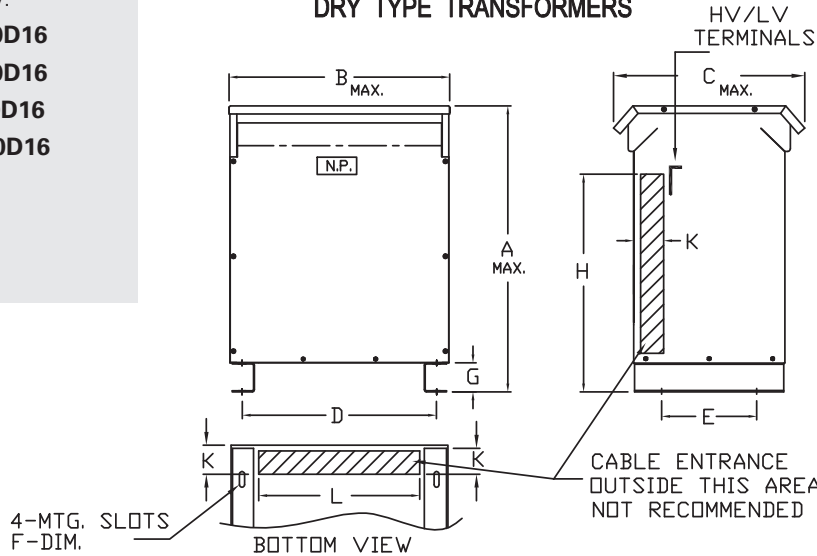

Reference Wiring Diagram Number Below:

T208B	T208D
T208F	T208G
T208I	T208J
T208K	T208L
T240B	T240D
T240E	T240F
T240H	T240I
T480E	T480G
T480J	T480K
T480M	T480N
T480P	T600G
T600I	plus others

TEMP RISE	K-FACTOR	WINDINGS	EFFICIENCY
150	K-20	ALUMINUM	DOE-2016

DIMENSIONS IN (E)=INCHES & (M)=CENTIMETERS

KVA	NET WT. LBS.	A		B		C		D		E		F		G		H		K		L	
		E	M	E	M	E	M	E	M	E	M	E	M	E	M	E	M	E	M	E	M
15	310	25.0	63.5	22.0	55.9	22.0	55.9	17.4	44.2	13.0	33.0	.56x1.13	1.42x2.87	3.0	7.6	13.0	33.0	3.0	7.6	15.0	38.1
30	425	28.0	71.1	25.0	63.5	23.5	59.7	20.8	52.7	14.5	36.8	.56x1.13	1.42x2.87	3.0	7.6	16.0	40.6	3.0	7.6	17.0	43.2
45	635	32.0	81.3	27.0	68.6	26.0	66.0	23.5	59.7	16.0	40.6	.56x1.13	1.42x2.87	3.0	7.6	18.0	45.7	3.0	7.6	20.0	50.8
75	850	38.0	96.5	29.0	73.7	29.0	73.7	25.5	64.8	18.0	45.7	.56x1.13	1.42x2.87	3.0	7.6	20.0	45.8	3.0	7.6	22.0	55.9
112.5	1035	42.0	107	33.0	83.8	32.5	82.6	29.5	74.9	21.0	53.3	.56x1.13	1.42x2.87	3.0	7.6	23.0	58.4	4.0	10.2	25.5	64.8
150	1350	46.0	117	35.0	88.9	37.0	94.0	31.5	80.0	25.0	63.5	.56x1.13	1.42x2.87	3.0	7.6	32.0	81.3	5.0	12.7	27.5	69.9
225	1675	52.0	132	35.0	88.9	37.0	94.0	31.5	80.0	25.0	63.5	.56x1.13	1.42x2.87	3.0	7.6	32.0	81.3	5.0	12.7	27.5	69.9
300	2150	60.0	154	48.0	122	43.5	110.5	42.0	107	27.0	68.6	.56x1.13	1.42x2.87	4.0	10.2	36.0	91.4	5.0	12.7	34.0	86.4
500	3150	72.0	183	52.0	132	44.0	112	34.0	86.4	42.0	107	.56x1.13	1.42x2.87	4.0	10.2	50.0	127	5.0	12.7	32.0	81.3
750		N/A																			
1000		N/A																			

NOTES:

- ALL UNITS ARE UL LISTED AND ARE DESIGNED IN ACCORDANCE WITH ANSI C89.2 AMD NEMA ST-20 STANDARDS.
- THESE TRANSFORMERS UTILIZE A UL RECOGNIZED 220°C INSULATION SYSTEM.
- TRANSFORMERS ARE DRY TYPE, CLASS AA, VENTILATED ENCLOSURE FOR INDOOR OR OUTDOOR USE.
- FOR LIFTING OTHER THAN WITH FORK TRUCK, REMOVE TOP COVER AND USE CORE CLAMPS.
- PAINT COLOR IS ANSI #61 GRAY.
- FULL WIDTH COPPER ELECTROSTATIC SHIELD.
- 6" REQUIRED CLEARANCE FROM THE WALLS.
- HV/LV TERMINALS ARE TOP FRONT TERMINATED.
- NET. WEIGHTS ARE APPROXIMATE.
- MEETS DOE-2016 EFFICIENCY 10 CFR PART 431

Siemens Industry, Inc.

GENERAL PURPOSE TRANSFORMERS
THREE-PHASE, 600 VOLTS CLASS, 60 HZ.

J214

REV. B

Aluminum K20 3-Phase Delta Primary Series J

DOE 2016 3-Phase Dry Type Ventilated Transformer

"F" Temp Rise – 115° C

Reference Siemens Series below:

3BxyyyK20FD16

3CxyyyK20FD16

3FxyyyK20FD16

3GxyyyK20FD16

plus others

SIEMENS DRY TYPE TRANSFORMERS

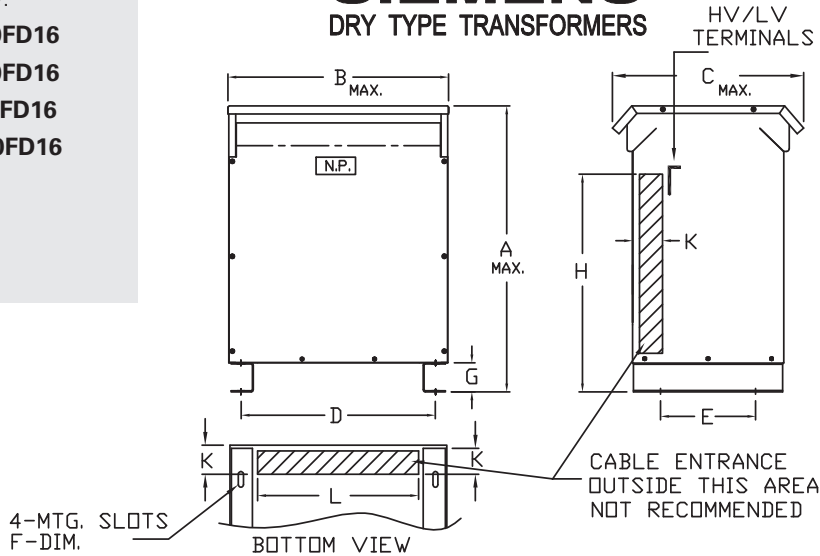

Reference Wiring Diagram Number Below:

T208B	T208D
T208F	T208G
T208I	T208J
T208K	T208L
T240B	T240D
T240E	T240F
T240H	T240I
T480E	T480G
T480J	T480K
T480M	T480N
T480P	T600G
T600I	plus others

TEMP RISE	K-FACTOR	WINDINGS	EFFICIENCY
115	K-20	ALUMINUM	DOE-2016

DIMENSIONS IN (E)=INCHES & (M)=CENTIMETERS

KVA	NET WT. LBS.	A		B		C		D		E		F		G		H		K		L	
		E	M	E	M	E	M	E	M	E	M	E	M	E	M	E	M	E	M	E	M
15	310	25.0	63.5	22.0	55.9	22.0	55.9	17.4	44.2	13.0	33.0	.56x1.13	1.42x2.87	3.0	7.6	13.0	33.0	3.0	7.6	15.0	38.1
30	400	28.0	71.1	25.0	63.5	23.5	59.7	20.8	52.7	14.5	36.8	.56x1.13	1.42x2.87	3.0	7.6	16.0	40.6	3.0	7.6	17.0	43.2
45	585	32.0	81.3	27.0	68.6	26.0	66.0	23.5	59.7	16.0	40.6	.56x1.13	1.42x2.87	3.0	7.6	18.0	45.7	3.0	7.6	20.0	50.8
75	775	38.0	96.5	29.0	73.7	29.0	73.7	25.5	64.8	18.0	45.7	.56x1.13	1.42x2.87	3.0	7.6	20.0	45.8	3.0	7.6	22.0	55.9
112.5	1000	42.0	107	33.0	83.8	32.5	82.6	29.5	74.9	21.0	53.3	.56x1.13	1.42x2.87	3.0	7.6	23.0	58.4	4.0	10.2	25.5	64.8
150	1315	46.0	117	35.0	88.9	37.0	94.0	31.5	80.0	25.0	63.5	.56x1.13	1.42x2.87	3.0	7.6	32.0	81.3	5.0	12.7	27.5	69.9
225	1665	52.0	132	35.0	88.9	37.0	94.0	31.5	80.0	25.0	63.5	.56x1.13	1.42x2.87	3.0	7.6	32.0	81.3	5.0	12.7	27.5	69.9
300	2460	60.0	154	48.0	122	43.5	110.5	42.0	107	27.0	68.6	.56x1.13	1.42x2.87	4.0	10.2	36.0	91.4	5.0	12.7	34.0	86.4
500	4300	72.0	183	52.0	132	44.0	112	34.0	86.4	42.0	107	.56x1.13	1.42x2.87	4.0	10.2	50.0	127	5.0	12.7	32.0	81.3
750		N/A																			
1000		N/A																			

NOTES:

- ALL UNITS ARE UL LISTED AND ARE DESIGNED IN ACCORDANCE WITH ANSI C89.2 AMD NEMA ST-20 STANDARDS.
- THESE TRANSFORMERS UTILIZE A UL RECOGNIZED 220°C INSULATION SYSTEM.
- TRANSFORMERS ARE DRY TYPE, CLASS AA, VENTILATED ENCLOSURE FOR INDOOR OR OUTDOOR USE.
- FOR LIFTING OTHER THAN WITH FORK TRUCK, REMOVE TOP COVER AND USE CORE CLAMPS.
- PAINT COLOR IS ANSI #61 GRAY.
- FULL WIDTH COPPER ELECTROSTATIC SHIELD.
- 6" REQUIRED CLEARANCE FROM THE WALLS.
- HV/LV TERMINALS ARE TOP FRONT TERMINATED.
- NET. WEIGHTS ARE APPROXIMATE.
- MEETS DOE-2016 EFFICIENCY 10 CFR PART 431

Siemens Industry, Inc.

GENERAL PURPOSE TRANSFORMERS
THREE-PHASE, 600 VOLTS CLASS, 60 HZ.

J215

REV.
B

Aluminum K20 3-Phase Delta Primary Series J

DOE 2016 3-Phase Dry Type Ventilated Transformer

"B" Temp Rise – 80° C

Reference Siemens Series below:

- 3BxxxxxK20BD16**
- 3CxxxxxK20BD16**
- 3FxxxxxK20BD16**
- 3GxxxxxK20BD16**
- plus others

SIEMENS DRY TYPE TRANSFORMERS

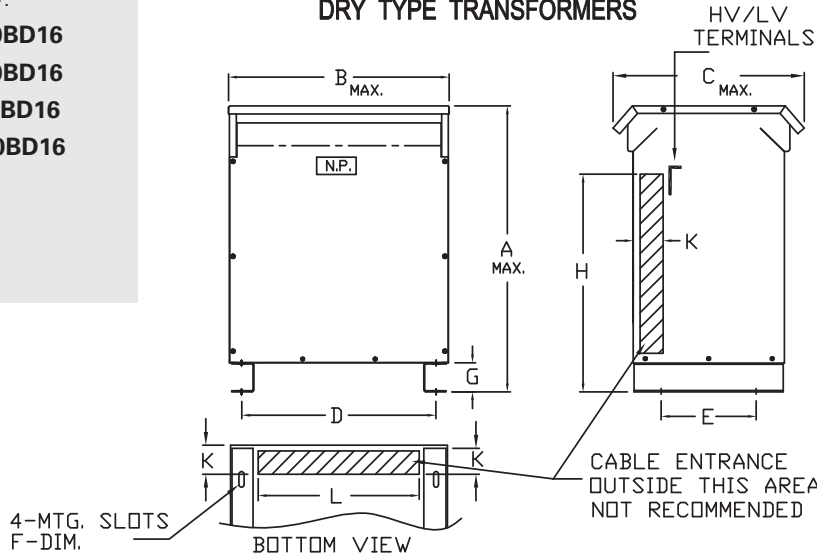

Reference Wiring Diagram Number Below:

T208B	T208D
T208F	T208G
T208I	T208J
T208K	T208L
T240B	T240D
T240E	T240F
T240H	T240I
T480E	T480G
T480J	T480K
T480M	T480N
T480P	T600G
T600I	plus others

TEMP RISE	K-FACTOR	WINDINGS	EFFICIENCY
80	K20	ALUMINUM	DOE-2016

DIMENSIONS IN (E)=INCHES & (M)=CENTIMETERS

KVA	NET WT. LBS.	A		B		C		D		E		F		G		H		K		L	
		E	M	E	M	E	M	E	M	E	M	E	M	E	M	E	M	E	M	E	M
15	310	25.0	63.5	22.0	55.9	22.0	55.9	17.4	44.1	13.0	33.0	.56x1.13	1.42x2.87	3.0	7.6	13.0	33.0	3.0	7.6	15.0	38.1
30	400	28.0	71.1	25.0	63.5	23.5	59.7	20.8	52.7	14.5	36.8	.56x1.13	1.42x2.87	3.0	7.6	16.0	40.6	3.0	7.6	17.0	43.2
45	585	32.0	81.3	27.0	68.6	26.0	66.0	23.5	59.7	16.0	40.6	.56x1.13	1.42x2.87	3.0	7.6	18.0	45.7	3.0	7.6	20.0	50.8
75	775	38.0	96.5	29.0	73.7	29.0	73.7	25.5	64.8	18.0	45.7	.56x1.13	1.42x2.87	3.0	7.6	20.0	45.8	3.0	7.6	22.0	55.9
112.5	1000	42.0	107	33.0	83.8	32.5	82.6	29.5	74.9	21.0	53.3	.56x1.13	1.42x2.87	3.0	7.6	23.0	58.4	4.0	10.2	25.5	64.8
150	1315	46.0	117	35.0	88.9	37.0	94.0	31.5	80.0	25.0	63.5	.56x1.13	1.42x2.87	3.0	7.6	32.0	81.3	5.0	12.7	27.5	69.9
225	1665	52.0	132	35.0	88.9	37.0	94.0	31.5	80.0	25.0	63.5	.56x1.13	1.42x2.87	3.0	7.6	32.0	81.3	5.0	12.7	27.5	69.9
300	2460	60.0	154	48.0	122	43.5	110.5	42.0	107	27.0	68.6	.56x1.13	1.42x2.87	4.0	10.2	36.0	91.4	5.0	12.7	34.0	86.4
500	4300	72.0	183	52.0	132	44.0	112	34.0	86.4	42.0	107	.56x1.13	1.42x2.87	4.0	10.2	50.0	112	5.0	12.7	32.0	81.3
750		N/A																			
1000		N/A																			

NOTES:

- ALL UNITS ARE UL LISTED AND ARE DESIGNED IN ACCORDANCE WITH ANSI C89.2 AND NEMA ST-20 STANDARDS.
- THESE TRANSFORMERS UTILIZE A UL RECOGNIZED 220°C INSULATION SYSTEM.
- TRANSFORMERS ARE DRY TYPE, CLASS AA, VENTILATED ENCLOSURE FOR INDOOR OR OUTDOOR USE.
- FOR LIFTING OTHER THAN WITH FORK TRUCK, REMOVE TOP COVER AND USE CORE CLAMPS.
- PAINT COLOR IS ANSI #61 GRAY.
- FULL WIDTH COPPER ELECTROSTATIC SHIELD.
- 6" REQUIRED CLEARANCE FROM THE WALLS.
- HV/LV TERMINALS ARE TOP FRONT TERMINATED.
- NET. WEIGHTS ARE APPROXIMATE.
- MEETS DOE-2016 EFFICIENCY 10 CFR PART 431

Siemens Industry, Inc.

GENERAL PURPOSE TRANSFORMERS
THREE-PHASE, 600 VOLTS CLASS, 60 HZ.

J230

REV. B

Copper K1 3-Phase Delta Primary Series J

DOE 2016 3-Phase Dry Type Ventilated Transformer

Standard Temp Rise – 150° C

Reference Siemens Series below:

- 3BxyyyCD16**
- 3CxyyyCD16**
- 3FxyyyCD16**
- 3GxyyyCD16**
- plus others

SIEMENS DRY TYPE TRANSFORMERS

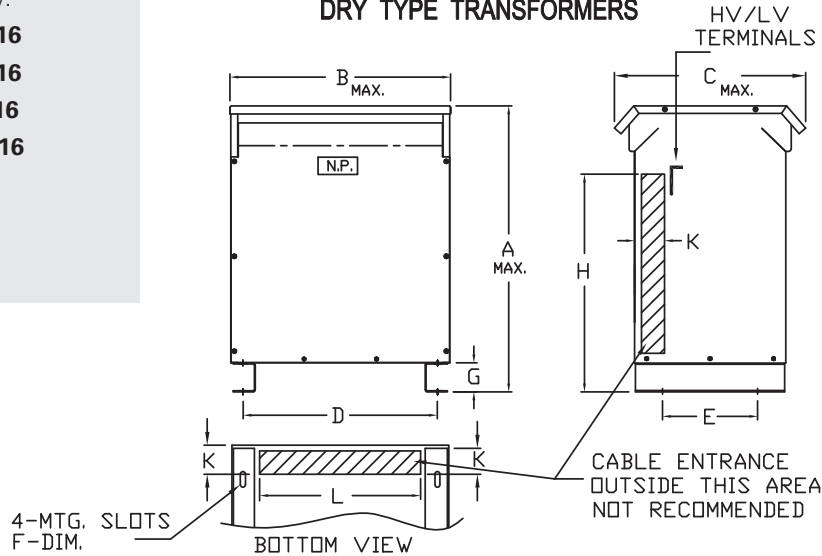

Reference Wiring Diagram Number Below:

T208B	T208D
T208F	T208G
T208I	T208J
T208K	T208L
T240B	T240D
T240E	T240F
T240H	T240I
T480E	T480G
T480J	T480K
T480M	T480N
T480P	T600G
T600I	plus others

TEMP RISE	K-FACTOR	WINDINGS	EFFICIENCY
150	K1	COPPER	DOE-2016

DIMENSIONS IN (E)=INCHES & (M)=CENTIMETERS

KVA	NET WT. LBS.	A		B		C		D		E		F		G		H		K		L	
		E	M	E	M	E	M	E	M	E	M	E	M	E	M	E	M	E	M		
15	250	22.0	55.9	19.0	48.3	21.0	53.3	16.8	41.6	12.0	30.5	.56x1.13	1.42x2.87	3.0	7.6	12.0	30.5	3.0	7.6	13.0	33.0
30	375	25.0	63.5	22.0	55.9	22.0	55.9	17.4	44.1	13.0	33.0	.56x1.13	1.42x2.87	3.0	7.6	13.0	33.0	3.0	7.6	15.0	38.1
45	500	28.0	71.1	25.0	63.5	23.5	59.7	20.8	52.7	14.5	36.8	.56x1.13	1.42x2.87	3.0	7.6	16.0	40.6	3.0	7.6	17.0	43.2
75	750	32.0	81.3	27.0	68.6	26.0	66.0	23.5	59.7	16.0	40.6	.56x1.13	1.42x2.87	3.0	7.6	18.0	45.7	3.0	7.6	20.0	50.8
112.5	975	38.0	96.5	29.0	73.7	29.0	73.7	25.5	64.8	18.0	45.7	.56x1.13	1.42x2.87	3.0	7.6	20.0	45.8	3.0	7.6	22.0	55.9
150	1250	42.0	107	33.0	83.8	32.5	82.6	29.5	74.9	21.0	53.3	.56x1.13	1.42x2.87	3.0	7.6	23.0	58.4	4.0	10.2	25.5	64.8
225	1650	46.0	117	35.0	88.9	37.0	94.0	31.5	80.0	25.0	63.5	.56x1.13	1.42x2.87	3.0	7.6	32.0	81.3	5.0	12.7	27.5	69.9
300	2100	52.0	132	35.0	88.9	37.0	94.0	31.5	80.0	25.0	63.5	.56x1.13	1.42x2.87	3.0	7.6	32.0	81.3	5.0	12.7	27.5	69.9
500	3100	60.0	154	48.0	122	43.5	110.5	42.0	107	27.0	68.6	.56x1.13	1.42x2.87	4.0	10.2	36.0	91.4	5.0	12.7	34.0	86.4
750	5375	72.0	183	52.0	132	44.0	112	34.0	86.4	42.0	107	.56x1.13	1.42x2.87	4.0	10.2	50.0	112	5.0	12.7	32.0	81.3
1000	6875	81.0	206	66.0	168	61.0	155	63.0	160	38.5	97.8	.56x1.13	1.42x2.87	5.0	12.7	60.0	152	6.0	15.2	48.0	122

NOTES:

- ALL UNITS ARE UL LISTED AND ARE DESIGNED IN ACCORDANCE WITH ANSI C89.2 AND NEMA ST-20 STANDARDS.
- THESE TRANSFORMERS UTILIZE A UL RECOGNIZED 220°C INSULATION SYSTEM.
- TRANSFORMERS ARE DRY TYPE, CLASS AA, VENTILATED ENCLOSURE FOR INDOOR OR OUTDOOR USE.
- FOR LIFTING OTHER THAN WITH FORK TRUCK, REMOVE TOP COVER AND USE CORE CLAMPS.
- PAINT COLOR IS ANSI #61 GRAY.
- FULL WIDTH COPPER ELECTROSTATIC SHIELD (OPTIONAL).
- 6" REQUIRED CLEARANCE FROM THE WALLS.
- HV/LV TERMINALS ARE TOP FRONT TERMINATED.
- NET. WEIGHTS ARE APPROXIMATE.
- MEETS DOE-2016 EFFICIENCY 10 CFR PART 431

Siemens Industry, Inc.

GENERAL PURPOSE TRANSFORMERS
THREE-PHASE, 600 VOLTS CLASS, 60 HZ.

J-216

REV. A

Copper K1 3-Phase Delta Primary Series J

DOE 2016 3-Phase Dry Type Ventilated Transformer

"F" Temp Rise – 115° C

Reference Siemens Series below:

- 3BxxxxxycFD16**
- 3CxxxxxycFD16**
- 3FxxxxxycFD16**
- 3GxxxxxycFD16**
- plus others

SIEMENS DRY TYPE TRANSFORMERS

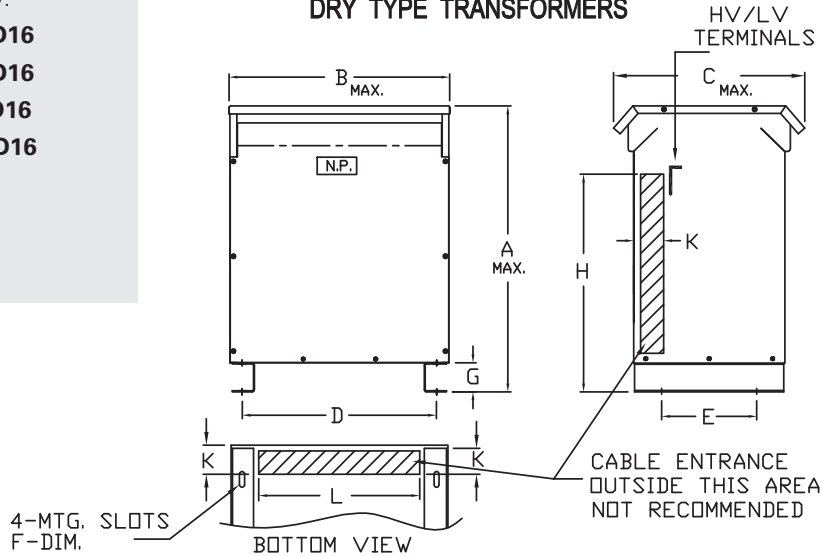

Reference Wiring Diagram Number Below:

T208B	T208D
T208F	T208G
T208I	T208J
T208K	T208L
T240B	T240D
T240E	T240F
T240H	T240I
T480E	T480G
T480J	T480K
T480M	T480N
T480P	T600G
T600I	plus others

TEMP RISE	K-FACTOR	WINDINGS	EFFICIENCY
115	K1	COPPER	DOE-2016

DIMENSIONS IN (E)=INCHES & (M)=CENTIMETERS

KVA	NET WT. LBS.	A		B		C		D		E		F		G		H		K		L	
		E	M	E	M	E	M	E	M	E	M	E	M	E	M	E	M	E	M	E	M
15	350	22.0	55.9	19.0	48.3	21.0	53.3	16.8	41.6	12.0	30.5	.56x1.13	1.42x2.87	3.0	7.6	12.0	30.5	3.0	7.6	13.0	33.0
30	475	25.0	63.5	22.0	55.9	22.0	55.9	17.4	44.1	13.0	33.0	.56x1.13	1.42x2.87	3.0	7.6	13.0	33.0	3.0	7.6	15.0	38.1
45	700	28.0	71.1	25.0	63.5	23.5	59.7	20.8	52.7	14.5	36.8	.56x1.13	1.42x2.87	3.0	7.6	16.0	40.6	3.0	7.6	17.0	43.2
75	925	32.0	81.3	27.0	68.6	26.0	66.0	23.5	59.7	16.0	40.6	.56x1.13	1.42x2.87	3.0	7.6	18.0	45.7	3.0	7.6	20.0	50.8
112.5	1200	38.0	96.5	29.0	73.7	29.0	73.7	25.5	64.8	18.0	45.7	.56x1.13	1.42x2.87	3.0	7.6	20.0	45.8	3.0	7.6	22.0	55.9
150	1600	42.0	107	33.0	83.8	32.5	82.6	29.5	74.9	21.0	53.3	.56x1.13	1.42x2.87	3.0	7.6	23.0	58.4	4.0	10.2	25.5	64.8
225	2050	46.0	117	35.0	88.9	37.0	94.0	31.5	80.0	25.0	63.5	.56x1.13	1.42x2.87	3.0	7.6	32.0	81.3	5.0	12.7	27.5	69.9
300	2100	52.0	132	35.0	88.9	37.0	94.0	31.5	80.0	25.0	63.5	.56x1.13	1.42x2.87	3.0	7.6	32.0	81.3	5.0	12.7	27.5	69.9
500	3100	60.0	154	48.0	122	43.5	110.5	42.0	107	27.0	68.6	.56x1.13	1.42x2.87	4.0	10.2	36.0	91.4	5.0	12.7	34.0	86.4
750	5375	81.0	206	66.0	168	61.0	155	63.0	160	38.5	97.8	.56x1.13	1.42x2.87	5.0	12.7	60.0	152	6.0	15.2	48.0	122
1000		N/A																			

NOTES:

- ALL UNITS ARE UL LISTED AND ARE DESIGNED IN ACCORDANCE WITH ANSI C89.2 AMD NEMA ST-20 STANDARDS.
- THESE TRANSFORMERS UTILIZE A UL RECOGNIZED 220°C INSULATION SYSTEM.
- TRANSFORMERS ARE DRY TYPE, CLASS AA, VENTILATED ENCLOSURE FOR INDOOR OR OUTDOOR USE.
- FOR LIFTING OTHER THAN WITH FORK TRUCK, REMOVE TOP COVER AND USE CORE CLAMPS.
- PAINT COLOR IS ANSI #61 GRAY.
- FULL WIDTH COPPER ELECTROSTATIC SHIELD (OPTIONAL).
- 6" REQUIRED CLEARANCE FROM THE WALLS.
- HV/LV TERMINALS ARE TOP FRONT TERMINATED.
- NET. WEIGHTS ARE APPROXIMATE.
- MEETS DOE-2016 EFFICIENCY 10 CFR PART 431

Siemens Industry, Inc.

GENERAL PURPOSE TRANSFORMERS
THREE-PHASE, 600 VOLTS CLASS, 60 HZ.

J-217

REV. A

Series J Addendum

Copper K1 3-Phase Delta Primary Series J

DOE 2016 3-Phase Dry Type Ventilated Transformer

"B" Temp Rise – 80° C

Reference Siemens Series below:

3BxyyyBCD16

3CxyyyBCD16

3FxyyyBCD16

3GxyyyBCD16

plus others

SIEMENS DRY TYPE TRANSFORMERS

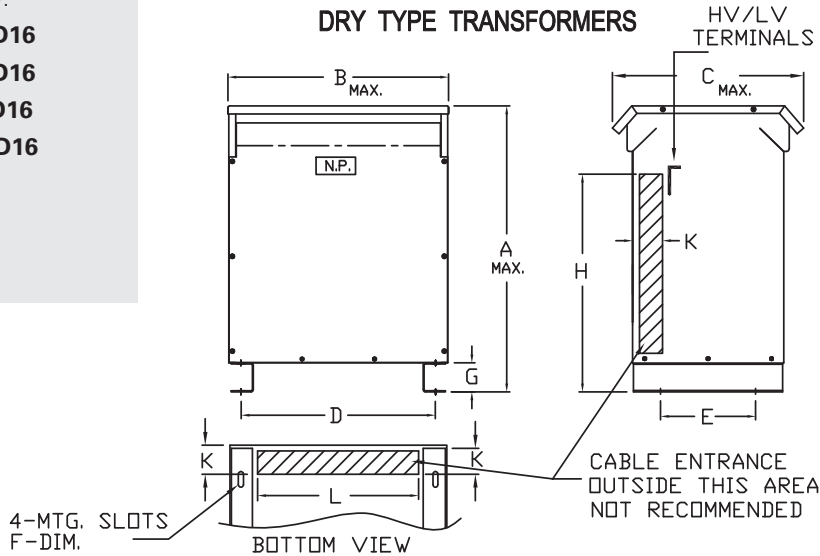

Reference Wiring Diagram Number Below:

T208B	T208D
T208F	T208G
T208I	T208J
T208K	T208L
T240B	T240D
T240E	T240F
T240H	T240I
T480E	T480G
T480J	T480K
T480M	T480N
T480P	T600G
T600I	plus others

TEMP RISE	K-FACTOR	WINDINGS	EFFICIENCY
80	K1	COPPER	DOE-2016

DIMENSIONS IN (E)=INCHES & (M)=CENTIMETERS

KVA	NET WT. LBS.	A		B		C		D		E		F		G		H		K		L	
		E	M	E	M	E	M	E	M	E	M	E	M	E	M	E	M	E	M	E	M
15	400	25.0	63.5	22.0	55.9	22.0	55.9	17.4	44.2	13.0	33.0	.56x1.13	1.42x2.87	3.0	7.6	13.0	33.0	3.0	7.6	15.0	38.1
30	525	28.0	71.1	25.0	63.5	23.5	59.7	20.8	52.7	14.5	36.8	.56x1.13	1.42x2.87	3.0	7.6	16.0	40.6	3.0	7.6	17.0	43.2
45	800	32.0	81.3	27.0	68.6	26.0	66.0	23.5	59.7	16.0	40.6	.56x1.13	1.42x2.87	3.0	7.6	18.0	45.7	3.0	7.6	20.0	50.8
75	1075	38.0	96.5	29.0	73.7	29.0	73.7	25.5	64.8	18.0	45.7	.56x1.13	1.42x2.87	3.0	7.6	20.0	45.8	3.0	7.6	22.0	55.9
112.5	1300	42.0	107	33.0	83.8	32.5	82.6	29.5	74.9	21.0	53.3	.56x1.13	1.42x2.87	3.0	7.6	23.0	58.4	4.0	10.2	25.5	64.8
150	1720	46.0	117	35.0	88.9	37.0	94.0	31.5	80.0	25.0	63.5	.56x1.13	1.42x2.87	3.0	7.6	32.0	81.3	5.0	12.7	27.5	69.9
225	2150	52.0	132	35.0	88.9	37.0	94.0	31.5	80.0	25.0	63.5	.56x1.13	1.42x2.87	3.0	7.6	32.0	81.3	5.0	12.7	27.5	69.9
300	3250	60.0	154	48.0	122	43.5	110.5	42.0	107	27.0	68.6	.56x1.13	1.42x2.87	4.0	10.2	36.0	91.4	5.0	12.7	34.0	86.4
500	4980	72.0	183	52.0	132	44.0	112	34.0	86.4	42.0	107	.56x1.13	1.42x2.87	4.0	10.2	50.0	127	5.0	12.7	32.0	81.3
750		N/A																			
1000		N/A																			

NOTES:

- ALL UNITS ARE UL LISTED AND ARE DESIGNED IN ACCORDANCE WITH ANSI C89.2 AMD NEMA ST-20 STANDARDS.
- THESE TRANSFORMERS UTILIZE A UL RECOGNIZED 220°C INSULATION SYSTEM.
- TRANSFORMERS ARE DRY TYPE, CLASS AA, VENTILATED ENCLOSURE FOR INDOOR OR OUTDOOR USE.
- FOR LIFTING OTHER THAN WITH FORK TRUCK, REMOVE TOP COVER AND USE CORE CLAMPS.
- PAINT COLOR IS ANSI #61 GRAY.
- FULL WIDTH COPPER ELECTROSTATIC SHIELD (OPTIONAL).
- 6" REQUIRED CLEARANCE FROM THE WALLS.
- HV/LV TERMINALS ARE TOP FRONT TERMINATED.
- NET. WEIGHTS ARE APPROXIMATE.
- MEETS DOE-2016 EFFICIENCY 10 CFR PART 431

Siemens Industry, Inc.

GENERAL PURPOSE TRANSFORMERS
THREE-PHASE, 600 VOLTS CLASS, 60 HZ.

J-218

REV.
A

Copper K4 3-Phase Delta Primary Series J

DOE 2016 3-Phase Dry Type Ventilated Transformer

Standard Temp Rise – 150° C

Reference Siemens Series below:

- 3BxyyyyK4CD16**
- 3CxyyyyK4CD16**
- 3FxyyyyK4CD16**
- 3GxyyyyK4CD16**
- plus others

SIEMENS DRY TYPE TRANSFORMERS

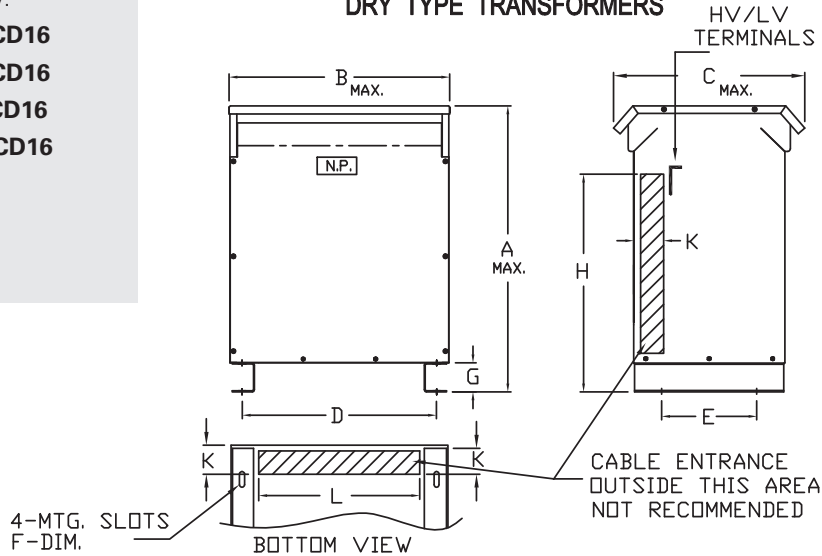

Reference Wiring Diagram Number Below:

T208B	T208D
T208F	T208G
T208I	T208J
T208K	T208L
T240B	T240D
T240E	T240F
T240H	T240I
T480E	T480G
T480J	T480K
T480M	T480N
T480P	T600G
T600I	plus others

TEMP RISE	K-FACTOR	WINDINGS	EFFICIENCY
150	K-4	COPPER	DOE-2016

DIMENSIONS IN (E)=INCHES & (M)=CENTIMETERS

KVA	NET WT. LBS.	A		B		C		D		E		F		G		H		K		L	
		E	M	E	M	E	M	E	M	E	M	E	M	E	M	E	M	E	M	E	M
15	215	22.0	55.9	19.0	48.3	21.0	53.3	16.8	41.6	12.0	30.5	.56x1.13	1.42x2.87	3.0	7.6	12.0	30.5	3.0	7.6	13.0	33.0
30	330	25.0	63.5	22.0	55.9	22.0	55.9	17.4	44.1	13.0	33.0	.56x1.13	1.42x2.87	3.0	7.6	13.0	33.0	3.0	7.6	15.0	38.1
45	415	28.0	71.1	25.0	63.5	23.5	59.7	20.8	52.7	14.5	36.8	.56x1.13	1.42x2.87	3.0	7.6	16.0	40.6	3.0	7.6	17.0	43.2
75	585	32.0	81.3	27.0	68.6	26.0	66.0	23.5	59.7	16.0	40.6	.56x1.13	1.42x2.87	3.0	7.6	18.0	45.7	3.0	7.6	20.0	50.8
112.5	795	38.0	96.5	29.0	73.7	29.0	73.7	25.5	64.8	18.0	45.7	.56x1.13	1.42x2.87	3.0	7.6	20.0	45.8	3.0	7.6	22.0	55.9
150	1035	42.0	107	33.0	83.8	32.5	82.6	29.5	74.9	21.0	53.3	.56x1.13	1.42x2.87	3.0	7.6	23.0	58.4	4.0	10.2	25.5	64.8
225	1430	46.0	117	35.0	88.9	37.0	94.0	31.5	80.0	25.0	63.5	.56x1.13	1.42x2.87	3.0	7.6	32.0	81.3	5.0	12.7	27.5	69.9
300	1755	52.0	132	35.0	88.9	37.0	94.0	31.5	80.0	25.0	63.5	.56x1.13	1.42x2.87	3.0	7.6	32.0	81.3	5.0	12.7	27.5	69.9
500	2760	60.0	154	48.0	122	43.5	110.5	42.0	107	27.0	68.6	.56x1.13	1.42x2.87	4.0	10.2	36.0	91.4	5.0	12.7	34.0	86.4
750	4150	72.0	183	52.0	132	44.0	112	34.0	86.4	42.0	107	.56x1.13	1.42x2.87	4.0	10.2	50.0	127	5.0	12.7	32.0	81.3
1000		N/A																			

NOTES:

- ALL UNITS ARE UL LISTED AND ARE DESIGNED IN ACCORDANCE WITH ANSI C89.2 AMD NEMA ST-20 STANDARDS.
- THESE TRANSFORMERS UTILIZE A UL RECOGNIZED 220°C INSULATION SYSTEM.
- TRANSFORMERS ARE DRY TYPE, CLASS AA, VENTILATED ENCLOSURE FOR INDOOR OR OUTDOOR USE.
- FOR LIFTING OTHER THAN WITH FORK TRUCK, REMOVE TOP COVER AND USE CORE CLAMPS.
- PAINT COLOR IS ANSI #61 GRAY.
- FULL WIDTH COPPER ELECTROSTATIC SHIELD.
- 6" REQUIRED CLEARANCE FROM THE WALLS.
- HV/LV TERMINALS ARE TOP FRONT TERMINATED.
- NET. WEIGHTS ARE APPROXIMATE.
- MEETS DOE-2016 EFFICIENCY 10 CFR PART 431

Siemens Industry, Inc.

GENERAL PURPOSE TRANSFORMERS
THREE-PHASE, 600 VOLTS CLASS, 60 HZ.

J221

REV. B

Copper K4 3-Phase Delta Primary Series J

DOE 2016 3-Phase Dry Type Ventilated Transformer

"F" Temp Rise – 115° C

Reference Siemens Series below:

- 3BxyyyK4FCD16**
- 3CxyyyK4FCD16**
- 3FxyyyK4FCD16**
- 3GxyyyK4FCD16**
- plus others

SIEMENS DRY TYPE TRANSFORMERS

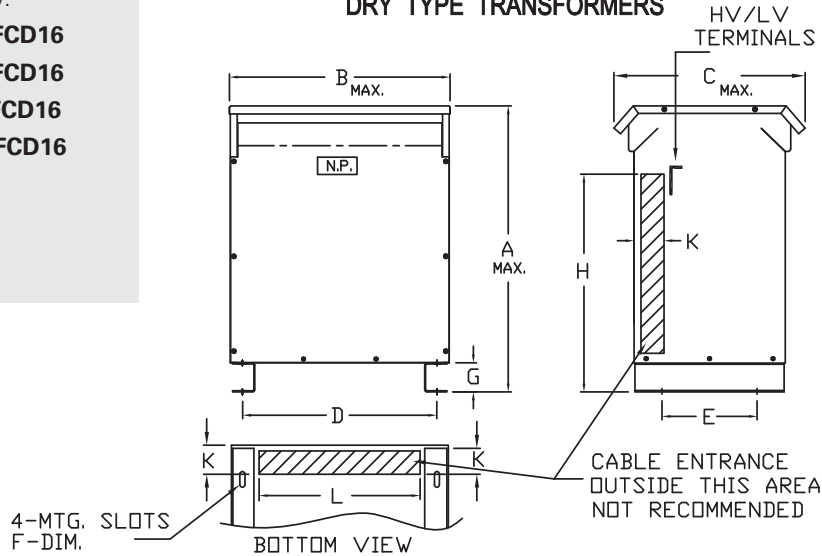

Reference Wiring Diagram Number Below:

T208B	T208D
T208F	T208G
T208I	T208J
T208K	T208L
T240B	T240D
T240E	T240F
T240H	T240I
T480E	T480G
T480J	T480K
T480M	T480N
T480P	T600G
T600I	plus others

TEMP RISE	K-FACTOR	WINDINGS	EFFICIENCY
115	K-4	COPPER	DOE-2016

DIMENSIONS IN (E)=INCHES & (M)=CENTIMETERS

KVA	NET WT. LBS.	A		B		C		D		E		F		G		H		K		L	
		E	M	E	M	E	M	E	M	E	M	E	M	E	M	E	M	E	M	E	M
15	215	22.0	55.9	19.0	48.3	21.0	53.3	16.8	41.6	12.0	30.5	.56x1.13	1.42x2.87	3.0	7.6	12.0	30.5	3.0	7.6	13.0	33.0
30	330	25.0	63.5	22.0	55.9	22.0	55.9	17.4	44.1	13.0	33.0	.56x1.13	1.42x2.87	3.0	7.6	13.0	33.0	3.0	7.6	15.0	38.1
45	415	28.0	71.1	25.0	63.5	23.5	59.7	20.8	52.7	14.5	36.8	.56x1.13	1.42x2.87	3.0	7.6	16.0	40.6	3.0	7.6	17.0	43.2
75	585	32.0	81.3	27.0	68.6	26.0	66.0	23.5	59.7	16.0	40.6	.56x1.13	1.42x2.87	3.0	7.6	18.0	45.7	3.0	7.6	20.0	50.8
112.5	795	38.0	96.5	29.0	73.7	29.0	73.7	25.5	64.8	18.0	45.7	.56x1.13	1.42x2.87	3.0	7.6	20.0	45.8	3.0	7.6	22.0	55.9
150	1035	42.0	107	33.0	83.8	32.5	82.6	29.5	74.9	21.0	53.3	.56x1.13	1.42x2.87	3.0	7.6	23.0	58.4	4.0	10.2	25.5	64.8
225	1430	46.0	117	35.0	88.9	37.0	94.0	31.5	80.0	25.0	63.5	.56x1.13	1.42x2.87	3.0	7.6	32.0	81.3	5.0	12.7	27.5	69.9
300	1755	52.0	132	35.0	88.9	37.0	94.0	31.5	80.0	25.0	63.5	.56x1.13	1.42x2.87	3.0	7.6	32.0	81.3	5.0	12.7	27.5	69.9
500	2760	60.0	154	48.0	122	43.5	110.5	42.0	107	27.0	68.6	.56x1.13	1.42x2.87	4.0	10.2	36.0	91.4	5.0	12.7	34.0	86.4
750	4150	72.0	183	52.0	132	44.0	112	34.0	86.4	42.0	107	.56x1.13	1.42x2.87	4.0	10.2	50.0	112	5.0	12.7	32.0	81.3
1000	6000	81.0	206	66.0	168	61.0	155	63.0	160	38.5	97.8	.56x1.13	1.42x2.87	5.0	12.7	60.0	152	6.0	15.2	48.0	122

NOTES:

- ALL UNITS ARE UL LISTED AND ARE DESIGNED IN ACCORDANCE WITH ANSI C89.2 AMD NEMA ST-20 STANDARDS.
- THESE TRANSFORMERS UTILIZE A UL RECOGNIZED 220°C INSULATION SYSTEM.
- TRANSFORMERS ARE DRY TYPE, CLASS AA, VENTILATED ENCLOSURE FOR INDOOR OR OUTDOOR USE.
- FOR LIFTING OTHER THAN WITH FORK TRUCK, REMOVE TOP COVER AND USE CORE CLAMPS.
- PAINT COLOR IS ANSI #61 GRAY.
- FULL WIDTH COPPER ELECTROSTATIC SHIELD.
- 6" REQUIRED CLEARANCE FROM THE WALLS.
- HV/LV TERMINALS ARE TOP FRONT TERMINATED.
- NET. WEIGHTS ARE APPROXIMATE.
- MEETS DOE-2016 EFFICIENCY 10 CFR PART 431

Siemens Industry, Inc.

GENERAL PURPOSE TRANSFORMERS
THREE-PHASE, 600 VOLTS CLASS, 60 HZ.

J222

REV. B

Copper K4 3-Phase Delta Primary Series J

DOE 2016 3-Phase Dry Type Ventilated Transformer

"B" Temp Rise – 80° C

Reference Siemens Series below:

- 3BxxxxxK4BCD16**
- 3CxxxxxK4BCD16**
- 3FxxxxxK4BCD16**
- 3GxxxxxK4BCD16**
- plus others

SIEMENS DRY TYPE TRANSFORMERS

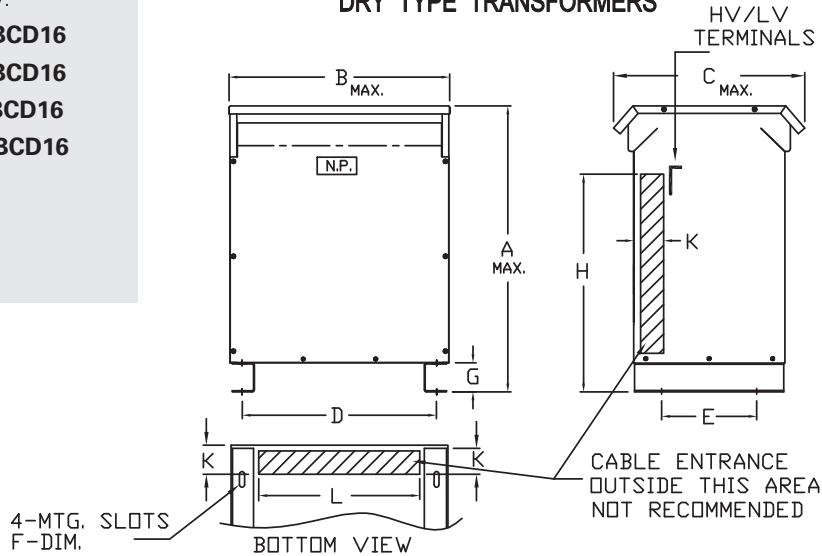

Reference Wiring Diagram Number Below:

T208B	T208D
T208F	T208G
T208I	T208J
T208K	T208L
T240B	T240D
T240E	T240F
T240H	T240I
T480E	T480G
T480J	T480K
T480M	T480N
T480P	T600G
T600I	plus others

TEMP RISE	K-FACTOR	WINDINGS	EFFICIENCY
80	K-4	COPPER	DOE-2016

DIMENSIONS IN (E)=INCHES & (M)=CENTIMETERS

KVA	NET WT. LBS.	A		B		C		D		E		F		G		H		K		L	
		E	M	E	M	E	M	E	M	E	M	E	M	E	M	E	M	E	M	E	M
15	310	25.0	63.5	22.0	55.9	22.0	55.9	17.4	44.2	13.0	33.0	.56x1.13	1.42x2.87	3.0	7.6	13.0	33.0	3.0	7.6	15.0	38.1
30	400	28.0	71.1	25.0	63.5	23.5	59.7	20.8	52.7	14.5	36.8	.56x1.13	1.42x2.87	3.0	7.6	16.0	40.6	3.0	7.6	17.0	43.2
45	585	32.0	81.3	27.0	68.6	26.0	66.0	23.5	59.7	16.0	40.6	.56x1.13	1.42x2.87	3.0	7.6	18.0	45.7	3.0	7.6	20.0	50.8
75	775	38.0	96.5	29.0	73.7	29.0	73.7	25.5	64.8	18.0	45.7	.56x1.13	1.42x2.87	3.0	7.6	20.0	45.8	3.0	7.6	22.0	55.9
112.5	1000	42.0	107	33.0	83.8	32.5	82.6	29.5	74.9	21.0	53.3	.56x1.13	1.42x2.87	3.0	7.6	23.0	58.4	4.0	10.2	25.5	64.8
150	1315	46.0	117	35.0	88.9	37.0	94.0	31.5	80.0	25.0	63.5	.56x1.13	1.42x2.87	3.0	7.6	32.0	81.3	5.0	12.7	27.5	69.9
225	1665	52.0	132	35.0	88.9	37.0	94.0	31.5	80.0	25.0	63.5	.56x1.13	1.42x2.87	3.0	7.6	32.0	81.3	5.0	12.7	27.5	69.9
300	2460	60.0	154	48.0	122	43.5	110.5	42.0	107	27.0	68.6	.56x1.13	1.42x2.87	4.0	10.2	36.0	91.4	5.0	12.7	34.0	86.4
500	4300	72.0	183	52.0	132	44.0	112	34.0	86.4	42.0	107	.56x1.13	1.42x2.87	4.0	10.2	50.0	127	5.0	12.7	32.0	81.3
750		N/A																			
1000		N/A																			

NOTES:

- ALL UNITS ARE UL LISTED AND ARE DESIGNED IN ACCORDANCE WITH ANSI C89.2 AMD NEMA ST-20 STANDARDS.
- THESE TRANSFORMERS UTILIZE A UL RECOGNIZED 220°C INSULATION SYSTEM.
- TRANSFORMERS ARE DRY TYPE, CLASS AA, VENTILATED ENCLOSURE FOR INDOOR OR OUTDOOR USE.
- FOR LIFTING OTHER THAN WITH FORK TRUCK, REMOVE TOP COVER AND USE CORE CLAMPS.
- PAINT COLOR IS ANSI #61 GRAY.
- FULL WIDTH COPPER ELECTROSTATIC SHIELD.
- 6" REQUIRED CLEARANCE FROM THE WALLS.
- HV/LV TERMINALS ARE TOP FRONT TERMINATED.
- NET. WEIGHTS ARE APPROXIMATE.
- MEETS DOE-2016 EFFICIENCY 10 CFR PART 431

Siemens Industry, Inc.

GENERAL PURPOSE TRANSFORMERS
THREE-PHASE, 600 VOLTS CLASS, 60 HZ.

J223

REV. B

Copper K13 3-Phase Delta Primary Series J

DOE 2016 3-Phase Dry Type Ventilated Transformer

Standard Temp Rise – 150° C

Reference Siemens Series below:

- 3BxyyyK13CD16**
- 3CxyyyK13CD16**
- 3FxyyyK13CD16**
- 3GxyyyK13CD16**
- plus others

SIEMENS DRY TYPE TRANSFORMERS

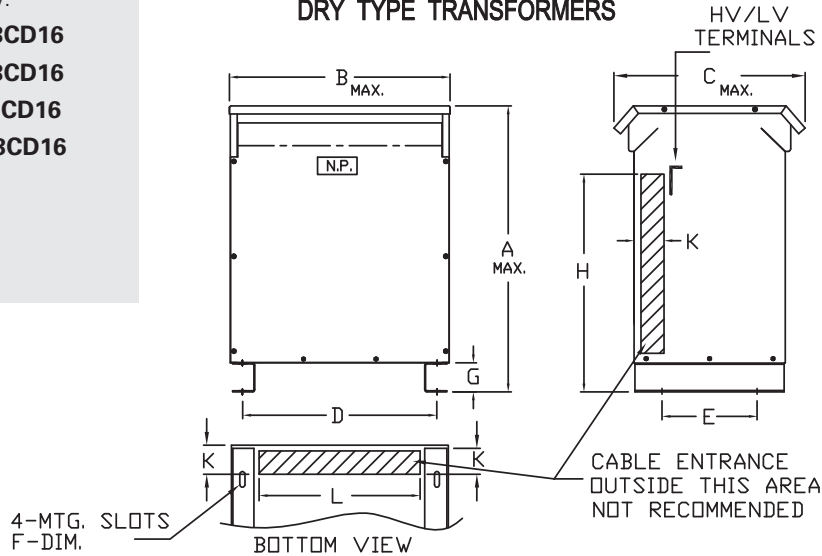

Reference Wiring Diagram Number Below:

T208B	T208D
T208F	T208G
T208I	T208J
T208K	T208L
T240B	T240D
T240E	T240F
T240H	T240I
T480E	T480G
T480J	T480K
T480M	T480N
T480P	T600G
T600I	plus others

TEMP RISE	K-FACTOR	WINDINGS	EFFICIENCY
150	K-13	COPPER	DOE-2016

DIMENSIONS IN (E)=INCHES & (M)=CENTIMETERS

KVA	NET WT. LBS.	A		B		C		D		E		F		G		H		K		L	
		E	M	E	M	E	M	E	M	E	M	E	M	E	M	E	M	E	M	E	M
15	330	25.0	63.5	22.0	55.9	22.0	55.9	17.4	44.2	13.0	33.0	.56x1.13	1.42x2.87	3.0	7.6	13.0	33.0	3.0	7.6	15.0	38.1
30	415	28.0	71.1	25.0	63.5	23.5	59.7	20.8	52.7	14.5	36.8	.56x1.13	1.42x2.87	3.0	7.6	16.0	40.6	3.0	7.6	17.0	43.2
45	585	32.0	81.3	27.0	68.6	26.0	66.0	23.5	59.7	16.0	40.6	.56x1.13	1.42x2.87	3.0	7.6	18.0	45.7	3.0	7.6	20.0	50.8
75	795	38.0	96.5	29.0	73.7	29.0	73.7	25.5	64.8	18.0	45.7	.56x1.13	1.42x2.87	3.0	7.6	20.0	45.8	3.0	7.6	22.0	55.9
112.5	1035	42.0	107	33.0	83.8	32.5	82.6	29.5	74.9	21.0	53.3	.56x1.13	1.42x2.87	3.0	7.6	23.0	58.4	4.0	10.2	25.5	64.8
150	1430	46.0	117	35.0	88.9	37.0	94.0	31.5	80.0	25.0	63.5	.56x1.13	1.42x2.87	3.0	7.6	32.0	81.3	5.0	12.7	27.5	69.9
225	1755	52.0	132	35.0	88.9	37.0	94.0	31.5	80.0	25.0	63.5	.56x1.13	1.42x2.87	3.0	7.6	32.0	81.3	5.0	12.7	27.5	69.9
300	2760	60.0	154	48.0	122	43.5	110.5	42.0	107	27.0	68.6	.56x1.13	1.42x2.87	4.0	10.2	36.0	91.4	5.0	12.7	34.0	86.4
500	4150	72.0	183	52.0	132	44.0	112	34.0	86.4	42.0	107	.56x1.13	1.42x2.87	4.0	10.2	50.0	127	5.0	12.7	32.0	81.3
750		N/A																			
1000		N/A																			

NOTES:

- ALL UNITS ARE UL LISTED AND ARE DESIGNED IN ACCORDANCE WITH ANSI C89.2 AMD NEMA ST-20 STANDARDS.
- THESE TRANSFORMERS UTILIZE A UL RECOGNIZED 220°C INSULATION SYSTEM.
- TRANSFORMERS ARE DRY TYPE, CLASS AA, VENTILATED ENCLOSURE FOR INDOOR OR OUTDOOR USE.
- FOR LIFTING OTHER THAN WITH FORK TRUCK, REMOVE TOP COVER AND USE CORE CLAMPS.
- PAINT COLOR IS ANSI #61 GRAY.
- FULL WIDTH COPPER ELECTROSTATIC SHIELD.
- 6" REQUIRED CLEARANCE FROM THE WALLS.
- HV/LV TERMINALS ARE TOP FRONT TERMINATED.
- NET. WEIGHTS ARE APPROXIMATE.
- MEETS DOE-2016 EFFICIENCY 10 CFR PART 431

Siemens Industry, Inc.

GENERAL PURPOSE TRANSFORMERS
THREE-PHASE, 600 VOLTS CLASS, 60 HZ.

J224

REV.
B

Copper K13 3-Phase Delta Primary Series J

DOE 2016 3-Phase Dry Type Ventilated Transformer

"F" Temp Rise – 115° C

Reference Siemens Series below:

3BxxxxxK13FCD16

3CxxxxxK13FCD16

3FxxxxxK13FCD16

3GxxxxxK13FCD16

plus others

SIEMENS DRY TYPE TRANSFORMERS

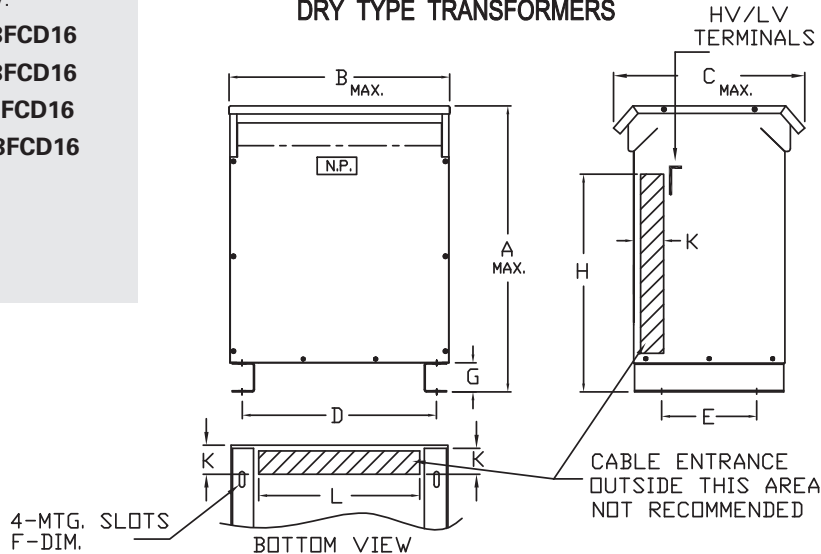

Reference Wiring Diagram Number Below:

T208B	T208D
T208F	T208G
T208I	T208J
T208K	T208L
T240B	T240D
T240E	T240F
T240H	T240I
T480E	T480G
T480J	T480K
T480M	T480N
T480P	T600G
T600I	plus others

TEMP RISE	K-FACTOR	WINDINGS	EFFICIENCY
115	K-13	COPPER	DOE-2016

DIMENSIONS IN (E)=INCHES & (M)=CENTIMETERS

KVA	NET WT. LBS.	A		B		C		D		E		F		G		H		K		L	
		E	M	E	M	E	M	E	M	E	M	E	M	E	M	E	M	E	M	E	M
15	330	25.0	63.5	22.0	55.9	22.0	55.9	17.4	44.2	13.0	33.0	.56x1.13	1.42x2.87	3.0	7.6	13.0	33.0	3.0	7.6	15.0	38.1
30	415	28.0	71.1	25.0	63.5	23.5	59.7	20.8	52.7	14.5	36.8	.56x1.13	1.42x2.87	3.0	7.6	16.0	40.6	3.0	7.6	17.0	43.2
45	585	32.0	81.3	27.0	68.6	26.0	66.0	23.5	59.7	16.0	40.6	.56x1.13	1.42x2.87	3.0	7.6	18.0	45.7	3.0	7.6	20.0	50.8
75	795	38.0	96.5	29.0	73.7	29.0	73.7	25.5	64.8	18.0	45.7	.56x1.13	1.42x2.87	3.0	7.6	20.0	45.8	3.0	7.6	22.0	55.9
112.5	1035	42.0	107	33.0	83.8	32.5	82.6	29.5	74.9	21.0	53.3	.56x1.13	1.42x2.87	3.0	7.6	23.0	58.4	4.0	10.2	25.5	64.8
150	1430	46.0	117	35.0	88.9	37.0	94.0	31.5	80.0	25.0	63.5	.56x1.13	1.42x2.87	3.0	7.6	32.0	81.3	5.0	12.7	27.5	69.9
225	1755	52.0	132	35.0	88.9	37.0	94.0	31.5	80.0	25.0	63.5	.56x1.13	1.42x2.87	3.0	7.6	32.0	81.3	5.0	12.7	27.5	69.9
300	2760	60.0	154	48.0	122	43.5	110.5	42.0	107	27.0	68.6	.56x1.13	1.42x2.87	4.0	10.2	36.0	91.4	5.0	12.7	34.0	86.4
500	4150	72.0	183	52.0	132	44.0	112	34.0	86.4	42.0	107	.56x1.13	1.42x2.87	4.0	10.2	50.0	127	5.0	12.7	32.0	81.3
750		N/A																			
1000		N/A																			

NOTES:

- ALL UNITS ARE UL LISTED AND ARE DESIGNED IN ACCORDANCE WITH ANSI C89.2 AMD NEMA ST-20 STANDARDS.
- THESE TRANSFORMERS UTILIZE A UL RECOGNIZED 220°C INSULATION SYSTEM.
- TRANSFORMERS ARE DRY TYPE, CLASS AA, VENTILATED ENCLOSURE FOR INDOOR OR OUTDOOR USE.
- FOR LIFTING OTHER THAN WITH FORK TRUCK, REMOVE TOP COVER AND USE CORE CLAMPS.
- PAINT COLOR IS ANSI #61 GRAY.
- FULL WIDTH COPPER ELECTROSTATIC SHIELD.
- 6" REQUIRED CLEARANCE FROM THE WALLS.
- HV/LV TERMINALS ARE TOP FRONT TERMINATED.
- NET. WEIGHTS ARE APPROXIMATE.
- MEETS DOE-2016 EFFICIENCY 10 CFR PART 431

Siemens Industry, Inc.

GENERAL PURPOSE TRANSFORMERS
THREE-PHASE, 600 VOLTS CLASS, 60 HZ.

J225

REV.
B

Copper K13 3-Phase Delta Primary Series J

DOE 2016 3-Phase Dry Type Ventilated Transformer

"B" Temp Rise – 80° C

Reference Siemens Series below:

- 3BxyyyK13BCD16**
- 3CxyyyK13BCD16**
- 3FxyyyK13BCD16**
- 3GxyyyK13BCD16**
- plus others

SIEMENS DRY TYPE TRANSFORMERS

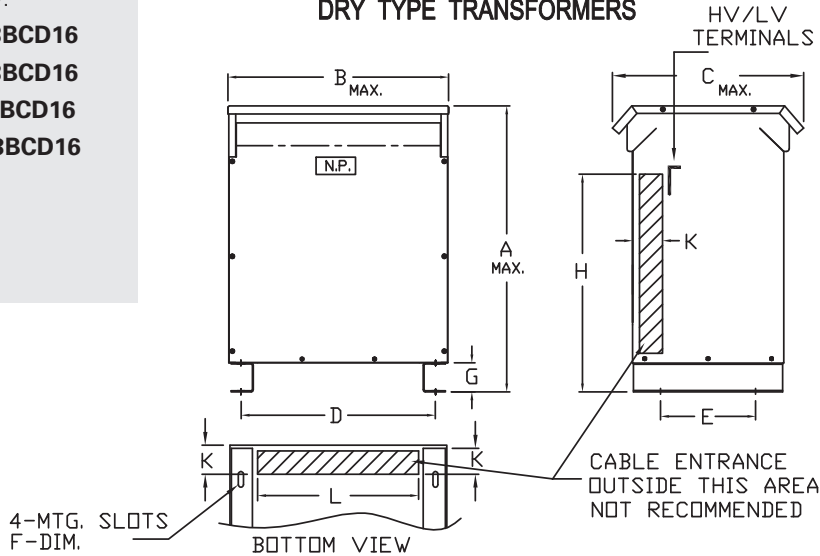

Reference Wiring Diagram Number Below:

T208B	T208D
T208F	T208G
T208I	T208J
T208K	T208L
T240B	T240D
T240E	T240F
T240H	T240I
T480E	T480G
T480J	T480K
T480M	T480N
T480P	T600G
T600I	plus others

TEMP RISE	K-FACTOR	WINDINGS	EFFICIENCY
80	K13	COPPER	DOE-2016

DIMENSIONS IN (E)=INCHES & (M)=CENTIMETERS

KVA	NET WT. LBS.	A		B		C		D		E		F		G		H		K		L	
		E	M	E	M	E	M	E	M	E	M	E	M	E	M	E	M	E	M	E	M
15	375	25.0	63.5	22.0	55.9	22.0	55.9	17.4	44.1	13.0	33.0	.56x1.13	1.42x2.87	3.0	7.6	13.0	33.0	3.0	7.6	15.0	38.1
30	500	28.0	71.1	25.0	63.5	23.5	59.7	20.8	52.7	14.5	36.8	.56x1.13	1.42x2.87	3.0	7.6	16.0	40.6	3.0	7.6	17.0	43.2
45	750	32.0	81.3	27.0	68.6	26.0	66.0	23.5	59.7	16.0	40.6	.56x1.13	1.42x2.87	3.0	7.6	18.0	45.7	3.0	7.6	20.0	50.8
75	975	38.0	96.5	29.0	73.7	29.0	73.7	25.5	64.8	18.0	45.7	.56x1.13	1.42x2.87	3.0	7.6	20.0	45.8	3.0	7.6	22.0	55.9
112.5	1250	42.0	107	33.0	83.8	32.5	82.6	29.5	74.9	21.0	53.3	.56x1.13	1.42x2.87	3.0	7.6	23.0	58.4	4.0	10.2	25.5	64.8
150	1650	46.0	117	35.0	88.9	37.0	94.0	31.5	80.0	25.0	63.5	.56x1.13	1.42x2.87	3.0	7.6	32.0	81.3	5.0	12.7	27.5	69.9
225	2100	52.0	132	35.0	88.9	37.0	94.0	31.5	80.0	25.0	63.5	.56x1.13	1.42x2.87	3.0	7.6	32.0	81.3	5.0	12.7	27.5	69.9
300	3100	60.0	154	48.0	122	43.5	110.5	42.0	107	27.0	68.6	.56x1.13	1.42x2.87	4.0	10.2	36.0	91.4	5.0	12.7	34.0	86.4
500	5375	72.0	183	52.0	132	44.0	112	34.0	86.4	42.0	107	.56x1.13	1.42x2.87	4.0	10.2	50.0	112	5.0	12.7	32.0	81.3
750		N/A																			
1000		N/A																			

NOTES:

- ALL UNITS ARE UL LISTED AND ARE DESIGNED IN ACCORDANCE WITH ANSI C89.2 AMD NEMA ST-20 STANDARDS.
- THESE TRANSFORMERS UTILIZE A UL RECOGNIZED 220°C INSULATION SYSTEM.
- TRANSFORMERS ARE DRY TYPE, CLASS AA, VENTILATED ENCLOSURE FOR INDOOR OR OUTDOOR USE.
- FOR LIFTING OTHER THAN WITH FORK TRUCK, REMOVE TOP COVER AND USE CORE CLAMPS.
- PAINT COLOR IS ANSI #61 GRAY.
- FULL WIDTH COPPER ELECTROSTATIC SHIELD.
- 6" REQUIRED CLEARANCE FROM THE WALLS.
- HV/LV TERMINALS ARE TOP FRONT TERMINATED.
- NET. WEIGHTS ARE APPROXIMATE.
- MEETS DOE-2016 EFFICIENCY 10 CFR PART 431

Siemens Industry, Inc.

GENERAL PURPOSE TRANSFORMERS
THREE-PHASE, 600 VOLTS CLASS, 60 HZ.

J229

REV.
B

Copper K20 3-Phase Delta Primary Series J

DOE 2016 3-Phase Dry Type Ventilated Transformer

Standard Temp Rise – 150° C

Reference Siemens Series below:

- 3BxxxxxK20CD16**
- 3CxxxxxK20CD16**
- 3FxxxxxK20CD16**
- 3GxxxxxK20CD16**
- plus others

SIEMENS DRY TYPE TRANSFORMERS

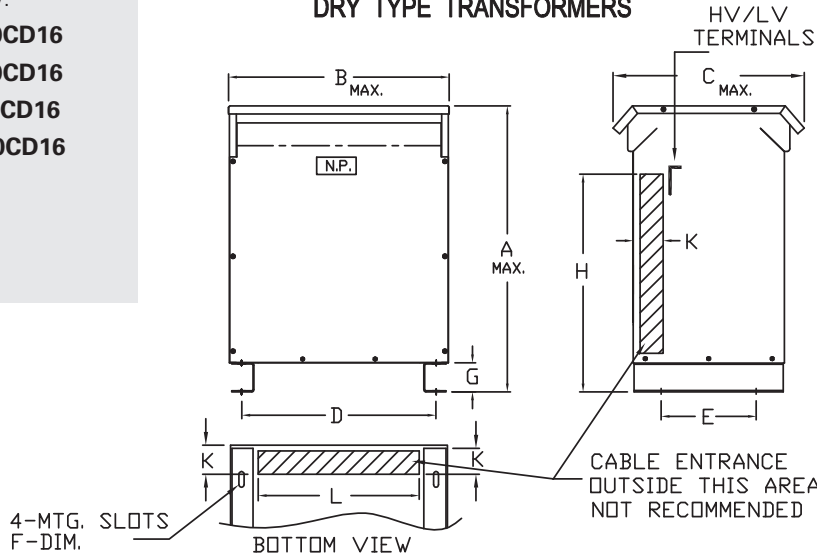

Reference Wiring Diagram Number Below:

T208B	T208D
T208F	T208G
T208I	T208J
T208K	T208L
T240B	T240D
T240E	T240F
T240H	T240I
T480E	T480G
T480J	T480K
T480M	T480N
T480P	T600G
T600I	plus others

TEMP RISE	K-FACTOR	WINDINGS	EFFICIENCY
150	K-20	COPPER	DOE-2016

DIMENSIONS IN (E)=INCHES & (M)=CENTIMETERS

KVA	NET WT. LBS.	A		B		C		D		E		F		G		H		K		L	
		E	M	E	M	E	M	E	M	E	M	E	M	E	M	E	M	E	M	E	M
15	310	25.0	63.5	22.0	55.9	22.0	55.9	17.4	44.2	13.0	33.0	.56x1.13	1.42x2.87	3.0	7.6	13.0	33.0	3.0	7.6	15.0	38.1
30	425	28.0	71.1	25.0	63.5	23.5	59.7	20.8	52.7	14.5	36.8	.56x1.13	1.42x2.87	3.0	7.6	16.0	40.6	3.0	7.6	17.0	43.2
45	635	32.0	81.3	27.0	68.6	26.0	66.0	23.5	59.7	16.0	40.6	.56x1.13	1.42x2.87	3.0	7.6	18.0	45.7	3.0	7.6	20.0	50.8
75	850	38.0	96.5	29.0	73.7	29.0	73.7	25.5	64.8	18.0	45.7	.56x1.13	1.42x2.87	3.0	7.6	20.0	45.8	3.0	7.6	22.0	55.9
112.5	1035	42.0	107	33.0	83.8	32.5	82.6	29.5	74.9	21.0	53.3	.56x1.13	1.42x2.87	3.0	7.6	23.0	58.4	4.0	10.2	25.5	64.8
150	1350	46.0	117	35.0	88.9	37.0	94.0	31.5	80.0	25.0	63.5	.56x1.13	1.42x2.87	3.0	7.6	32.0	81.3	5.0	12.7	27.5	69.9
225	1675	52.0	132	35.0	88.9	37.0	94.0	31.5	80.0	25.0	63.5	.56x1.13	1.42x2.87	3.0	7.6	32.0	81.3	5.0	12.7	27.5	69.9
300	2150	60.0	154	48.0	122	43.5	110.5	42.0	107	27.0	68.6	.56x1.13	1.42x2.87	4.0	10.2	36.0	91.4	5.0	12.7	34.0	86.4
500	3150	72.0	183	52.0	132	44.0	112	34.0	86.4	42.0	107	.56x1.13	1.42x2.87	4.0	10.2	50.0	127	5.0	12.7	32.0	81.3
750		N/A																			
1000		N/A																			

NOTES:

- ALL UNITS ARE UL LISTED AND ARE DESIGNED IN ACCORDANCE WITH ANSI C89.2 AND NEMA ST-20 STANDARDS.
- THESE TRANSFORMERS UTILIZE A UL RECOGNIZED 220°C INSULATION SYSTEM.
- TRANSFORMERS ARE DRY TYPE, CLASS AA, VENTILATED ENCLOSURE FOR INDOOR OR OUTDOOR USE.
- FOR LIFTING OTHER THAN WITH FORK TRUCK, REMOVE TOP COVER AND USE CORE CLAMPS.
- PAINT COLOR IS ANSI #61 GRAY.
- FULL WIDTH COPPER ELECTROSTATIC SHIELD.
- 6" REQUIRED CLEARANCE FROM THE WALLS.
- HV/LV TERMINALS ARE TOP FRONT TERMINATED.
- NET. WEIGHTS ARE APPROXIMATE.
- MEETS DOE-2016 EFFICIENCY 10 CFR PART 431

Siemens Industry, Inc.

GENERAL PURPOSE TRANSFORMERS
THREE-PHASE, 600 VOLTS CLASS, 60 HZ.

J226

REV. B

Copper K20 3-Phase Delta Primary Series J

DOE 2016 3-Phase Dry Type Ventilated Transformer

"F" Temp Rise – 115° C

Reference Siemens Series below:

- 3BxyyyK20FCD16**
- 3CxyyyK20FCD16**
- 3FxyyyK20FCD16**
- 3GxyyyK20FCD16**
- plus others

SIEMENS DRY TYPE TRANSFORMERS

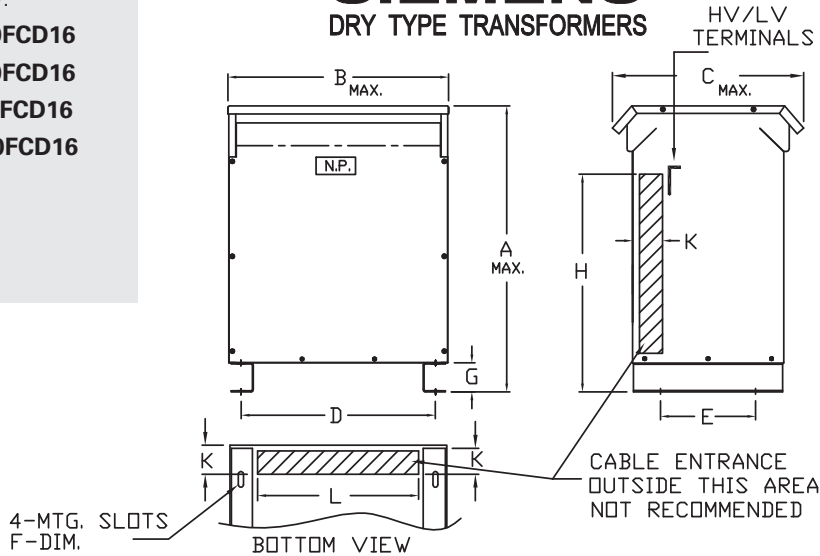

Reference Wiring Diagram Number Below:

T208B	T208D
T208F	T208G
T208I	T208J
T208K	T208L
T240B	T240D
T240E	T240F
T240H	T240I
T480E	T480G
T480J	T480K
T480M	T480N
T480P	T600G
T600I	plus others

TEMP RISE	K-FACTOR	WINDINGS	EFFICIENCY
115	K-20	COPPER	DOE-2016

DIMENSIONS IN (E)=INCHES & (M)=CENTIMETERS

KVA	NET WT. LBS.	A		B		C		D		E		F		G		H		K		L	
		E	M	E	M	E	M	E	M	E	M	E	M	E	M	E	M	E	M		
15	310	25.0	63.5	22.0	55.9	22.0	55.9	17.4	44.2	13.0	33.0	.56x1.13	1.42x2.87	3.0	7.6	13.0	33.0	3.0	7.6	15.0	38.1
30	400	28.0	71.1	25.0	63.5	23.5	59.7	20.8	52.7	14.5	36.8	.56x1.13	1.42x2.87	3.0	7.6	16.0	40.6	3.0	7.6	17.0	43.2
45	585	32.0	81.3	27.0	68.6	26.0	66.0	23.5	59.7	16.0	40.6	.56x1.13	1.42x2.87	3.0	7.6	18.0	45.7	3.0	7.6	20.0	50.8
75	775	38.0	96.5	29.0	73.7	29.0	73.7	25.5	64.8	18.0	45.7	.56x1.13	1.42x2.87	3.0	7.6	20.0	45.8	3.0	7.6	22.0	55.9
112.5	1000	42.0	107	33.0	83.8	32.5	82.6	29.5	74.9	21.0	53.3	.56x1.13	1.42x2.87	3.0	7.6	23.0	58.4	4.0	10.2	25.5	64.8
150	1315	46.0	117	35.0	88.9	37.0	94.0	31.5	80.0	25.0	63.5	.56x1.13	1.42x2.87	3.0	7.6	32.0	81.3	5.0	12.7	27.5	69.9
225	1665	52.0	132	35.0	88.9	37.0	94.0	31.5	80.0	25.0	63.5	.56x1.13	1.42x2.87	3.0	7.6	32.0	81.3	5.0	12.7	27.5	69.9
300	2460	60.0	154	48.0	122	43.5	110.5	42.0	107	27.0	68.6	.56x1.13	1.42x2.87	4.0	10.2	36.0	91.4	5.0	12.7	34.0	86.4
500	4300	72.0	183	52.0	132	44.0	112	34.0	86.4	42.0	107	.56x1.13	1.42x2.87	4.0	10.2	50.0	127	5.0	12.7	32.0	81.3
750		N/A																			
1000		N/A																			

NOTES:

- ALL UNITS ARE UL LISTED AND ARE DESIGNED IN ACCORDANCE WITH ANSI C89.2 AMD NEMA ST-20 STANDARDS.
- THESE TRANSFORMERS UTILIZE A UL RECOGNIZED 220°C INSULATION SYSTEM.
- TRANSFORMERS ARE DRY TYPE, CLASS AA, VENTILATED ENCLOSURE FOR INDOOR OR OUTDOOR USE.
- FOR LIFTING OTHER THAN WITH FORK TRUCK, REMOVE TOP COVER AND USE CORE CLAMPS.
- PAINT COLOR IS ANSI #61 GRAY.
- FULL WIDTH COPPER ELECTROSTATIC SHIELD.
- 6" REQUIRED CLEARANCE FROM THE WALLS.
- HV/LV TERMINALS ARE TOP FRONT TERMINATED.
- NET. WEIGHTS ARE APPROXIMATE.
- MEETS DOE-2016 EFFICIENCY 10 CFR PART 431

Siemens Industry, Inc.

GENERAL PURPOSE TRANSFORMERS
THREE-PHASE, 600 VOLTS CLASS, 60 HZ.

J227

REV.
B

Copper K20 3-Phase Delta Primary Series J

DOE 2016 3-Phase Dry Type Ventilated Transformer

"B" Temp Rise – 80° C

Reference Siemens Series below:

- 3BxxxxxK20BCD16**
- 3CxxxxxK20BCD16**
- 3FxxxxxK20BCD16**
- 3GxxxxxK20BCD16**
- plus others

SIEMENS DRY TYPE TRANSFORMERS

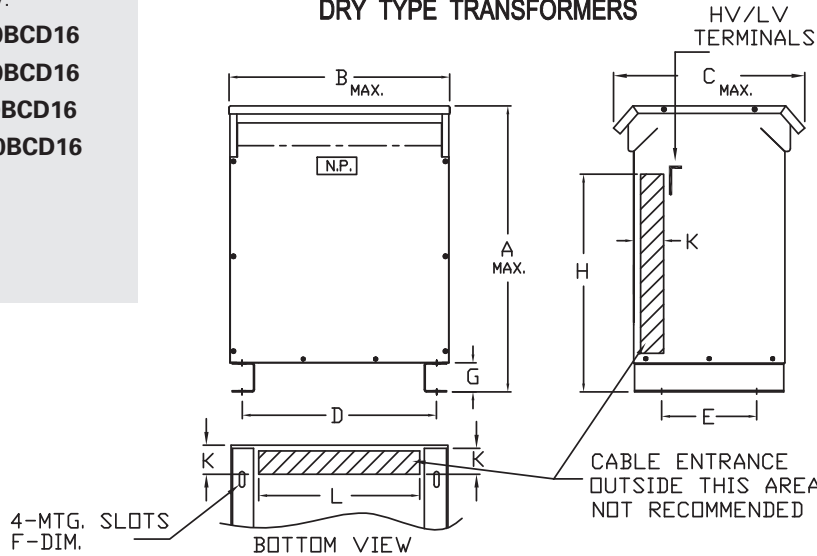

Reference Wiring Diagram Number Below:

T208B	T208D
T208F	T208G
T208I	T208J
T208K	T208L
T240B	T240D
T240E	T240F
T240H	T240I
T480E	T480G
T480J	T480K
T480M	T480N
T480P	T600G
T600I	plus others

TEMP RISE	K-FACTOR	WINDINGS	EFFICIENCY
80	K20	COPPER	DOE-2016

DIMENSIONS IN (E)=INCHES & (M)=CENTIMETERS

KVA	NET WT. LBS.	A		B		C		D		E		F		G		H		K		L	
		E	M	E	M	E	M	E	M	E	M	E	M	E	M	E	M	E	M	E	M
15	375	25.0	63.5	22.0	55.9	22.0	55.9	17.4	44.1	13.0	33.0	.56x1.13	1.42x2.87	3.0	7.6	13.0	33.0	3.0	7.6	15.0	38.1
30	500	28.0	71.1	25.0	63.5	23.5	59.7	20.8	52.7	14.5	36.8	.56x1.13	1.42x2.87	3.0	7.6	16.0	40.6	3.0	7.6	17.0	43.2
45	750	32.0	81.3	27.0	68.6	26.0	66.0	23.5	59.7	16.0	40.6	.56x1.13	1.42x2.87	3.0	7.6	18.0	45.7	3.0	7.6	20.0	50.8
75	975	38.0	96.5	29.0	73.7	29.0	73.7	25.5	64.8	18.0	45.7	.56x1.13	1.42x2.87	3.0	7.6	20.0	45.8	3.0	7.6	22.0	55.9
112.5	1250	42.0	107	33.0	83.8	32.5	82.6	29.5	74.9	21.0	53.3	.56x1.13	1.42x2.87	3.0	7.6	23.0	58.4	4.0	10.2	25.5	64.8
150	1650	46.0	117	35.0	88.9	37.0	94.0	31.5	80.0	25.0	63.5	.56x1.13	1.42x2.87	3.0	7.6	32.0	81.3	5.0	12.7	27.5	69.9
225	2100	52.0	132	35.0	88.9	37.0	94.0	31.5	80.0	25.0	63.5	.56x1.13	1.42x2.87	3.0	7.6	32.0	81.3	5.0	12.7	27.5	69.9
300	3100	60.0	154	48.0	122	43.5	110.5	42.0	107	27.0	68.6	.56x1.13	1.42x2.87	4.0	10.2	36.0	91.4	5.0	12.7	34.0	86.4
500	5375	72.0	183	52.0	132	44.0	112	34.0	86.4	42.0	107	.56x1.13	1.42x2.87	4.0	10.2	50.0	112	5.0	12.7	32.0	81.3
750		N/A																			
1000		N/A																			

NOTES:

- ALL UNITS ARE UL LISTED AND ARE DESIGNED IN ACCORDANCE WITH ANSI C89.2 AMD NEMA ST-20 STANDARDS.
- THESE TRANSFORMERS UTILIZE A UL RECOGNIZED 220°C INSULATION SYSTEM.
- TRANSFORMERS ARE DRY TYPE, CLASS AA, VENTILATED ENCLOSURE FOR INDOOR OR OUTDOOR USE.
- FOR LIFTING OTHER THAN WITH FORK TRUCK, REMOVE TOP COVER AND USE CORE CLAMPS.
- PAINT COLOR IS ANSI #61 GRAY.
- FULL WIDTH COPPER ELECTROSTATIC SHIELD.
- 6" REQUIRED CLEARANCE FROM THE WALLS.
- HV/LV TERMINALS ARE TOP FRONT TERMINATED.
- NET. WEIGHTS ARE APPROXIMATE.
- MEETS DOE-2016 EFFICIENCY 10 CFR PART 431

Siemens Industry, Inc.

GENERAL PURPOSE TRANSFORMERS
THREE-PHASE, 600 VOLTS CLASS, 60 HZ.

J231

REV. B

Wiring Diagrams

T208A Wiring Diagram & Connections*

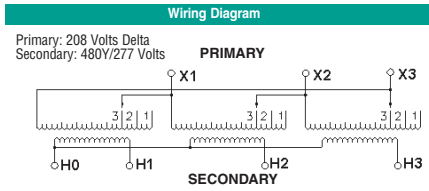

Connections		
Primary Volts	Jumper Taps To	Primary Lines Connect To
208	1	X1, X2, X3
198	2	X1, X2, X3
187	3	X1, X2, X3
Sec. Volts	Secondary Lines Connect To	
480	H1, H2, H3	
277	Between H0 and H1 or H2 or H3	
1 Phase		

T208B Wiring Diagram & Connections*

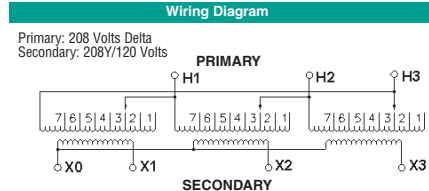

Connections		
Primary Volts	On Each Coil Jumper Taps To	Primary Lines Connect To
218	1	H1, H2, H3
213	2	H1, H2, H3
208	3	H1, H2, H3
203	4	H1, H2, H3
198	5	H1, H2, H3
192	6	H1, H2, H3
187	7	H1, H2, H3
Sec. Volts	Secondary Lines Connect To	
208	X1, X2, X3	
120	Between X0 and X1 or X2 or X3	
1 Phase		

T208D Wiring Diagram & Connections*

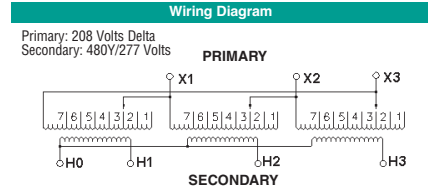

Connections		
Primary Volts	On Each Coil Jumper Taps To	Primary Lines Connect To
218	1	X1, X2, X3
213	2	X1, X2, X3
208	3	X1, X2, X3
203	4	X1, X2, X3
198	5	X1, X2, X3
192	6	X1, X2, X3
187	7	X1, X2, X3
Sec. Volts	Secondary Lines Connect To	
480	H1, H2, H3	
277	Between H0 and H1 or H2 or H3	
1 Phase		

T208F Wiring Diagram & Connections*

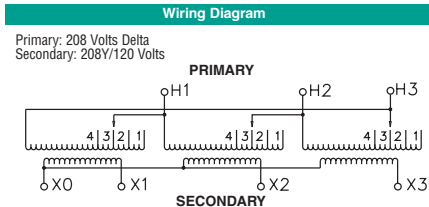

Connections		
Primary Volts	On Each Coil Jumper Taps To	Primary Lines Connect To
218	1	H1, H2, H3
208	2	H1, H2, H3
198	3	H1, H2, H3
187	4	H1, H2, H3
Sec. Volts	Secondary Lines Connect To	
208	X1, X2, X3	
120	Between X0 and X1 or X2 or X3	
1 Phase		

T208G Wiring Diagram & Connections*

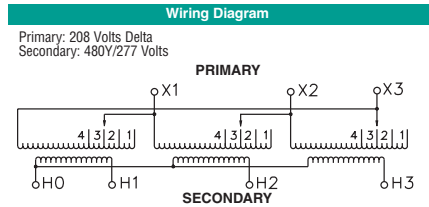

Connections		
Primary Volts	On Each Coil Jumper Taps To	Primary Lines Connect To
218	1	X1, X2, X3
208	2	X1, X2, X3
198	3	X1, X2, X3
187	4	X1, X2, X3
Sec. Volts	Secondary Lines Connect To	
480	H1, H2, H3	
277	Between H0 and H1 or H2 or H3	
1 Phase		

T208H Wiring Diagram & Connections*

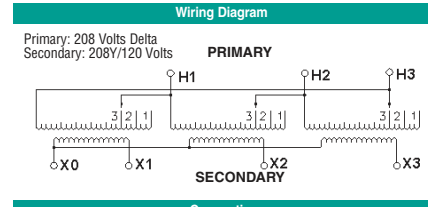

Connections		
Primary Volts	Jumper Taps To	Primary Lines Connect To
208	1	H1, H2, H3
198	2	H1, H2, H3
187	3	H1, H2, H3
Sec. Volts	Secondary Lines Connect To	
208	X1, X2, X3	
120	Between X0 and X1 or X2 or X3	
1 Phase		

T208I Wiring Diagram & Connections*

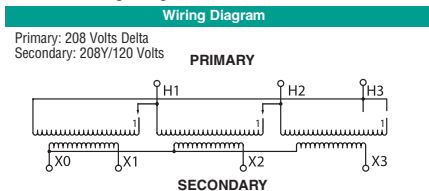

Connections		
Primary Volts	On Each Coil Jumper Taps To	Primary Lines Connect To
208	1	H1, H2, H3
Sec. Volts	Secondary Lines Connect To	
208	X1, X2, X3	
120	Between X0 and X1 or X2 or X3	
1 Phase		

T208J Wiring Diagram & Connections*

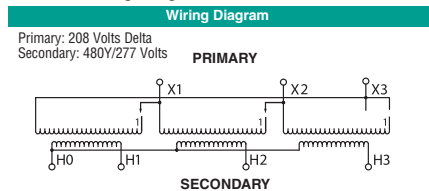

Connections		
Primary Volts	On Each Coil Jumper Taps To	Primary Lines Connect To
208	1	X1, X2, X3
Sec. Volts	Secondary Lines Connect To	
480	H1, H2, H3	
277	Between H0 and H1 or H2 or H3	
1 Phase		

T208K Wiring Diagram & Connections*

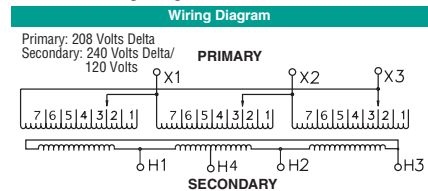

Connections		
Primary Volts	On Each Coil Jumper Taps To	Primary Lines Connect To
218	1	X1, X2, X3
213	2	X1, X2, X3
208	3	X1, X2, X3
203	4	X1, X2, X3
198	5	X1, X2, X3
192	6	X1, X2, X3
187	7	X1, X2, X3
Sec. Volts	Secondary Lines Connect To	
240	H1, H2, H3	
120	H1 and H4 or H2 and H4	
1 Phase		

Wiring Diagrams

T208L Wiring Diagram & Connections*

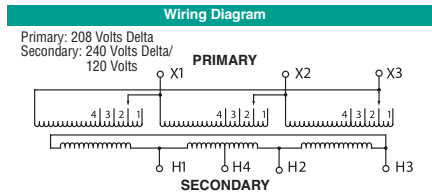

Connections		
Primary Volts	On Each Coil Jumper Taps To	Primary Lines Connect To
218	1	H1, H2, H3
208	2	H1, H2, H3
198	3	H1, H2, H3
187	4	H1, H2, H3
Sec. Volts	Secondary Lines Connect To	
240	H1, H2, H3	
120	H1 and H4 or H2 and H4	
1 Phase		

T240A Wiring Diagram & Connections*

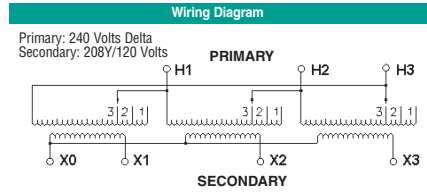

Connections		
Primary Volts	Jumper Taps To	Primary Lines Connect To
240	1	H1, H2, H3
228	2	H1, H2, H3
216	3	H1, H2, H3
Sec. Volts	Secondary Lines Connect To	
208	X1, X2, X3	
120	Between X0 and X1 or X2 or X3	
1 phase		

T240B Wiring Diagram & Connections*

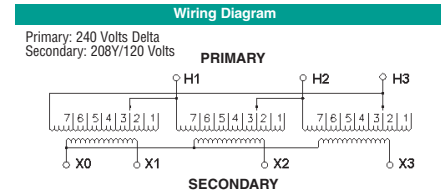

Connections		
Primary Volts	On Each Coil Jumper Taps To	Primary Lines Connect To
252	1	H1, H2, H3
246	2	H1, H2, H3
240	3	H1, H2, H3
234	4	H1, H2, H3
228	5	H1, H2, H3
222	6	H1, H2, H3
216	7	H1, H2, H3
Sec. Volts	Secondary Lines Connect To	
208	X1, X2, X3	
120	Between X0 and X1 or X2 or X3	
1 Phase		

T240D Wiring Diagram & Connections*

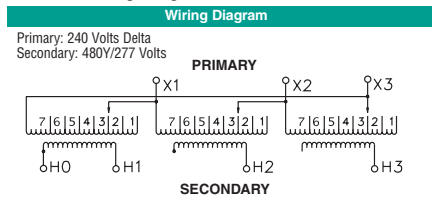

Connections		
Primary Volts	On Each Coil Jumper Taps To	Primary Lines Connect To
252	1	X1, X2, X3
246	2	X1, X2, X3
240	3	X1, X2, X3
234	4	X1, X2, X3
228	5	X1, X2, X3
222	6	X1, X2, X3
216	7	X1, X2, X3
Sec. Volts	Secondary Lines Connect To	
480	H1, H2, H3	
277	Between H0 and H1 or H2 or H3	
1 Phase		

T240E Wiring Diagram & Connections*

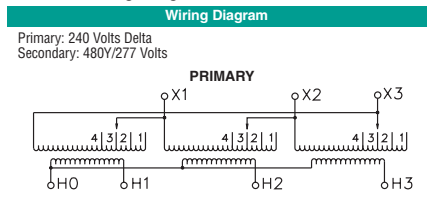

Connections		
Primary Volts	On Each Coil Jumper Taps To	Primary Lines Connect To
252	1	X1, X2, X3
240	2	X1, X2, X3
228	3	X1, X2, X3
216	4	X1, X2, X3
Sec. Volts	Secondary Lines Connect To	
480	H1, H2, H3	
277	Between H0 and H1 or H2, or H3	
1 Phase		

T240F Wiring Diagram & Connections*

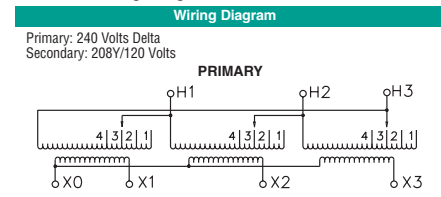

Connections		
Primary Volts	On Each Coil Jumper Taps To	Primary Lines Connect To
252	1	H1, H2, H3
240	2	H1, H2, H3
228	3	H1, H2, H3
216	4	H1, H2, H3
Sec. Volts	Secondary Lines Connect To	
208	X1, X2, X3	
120	Between X0 and X1 or X2, or X3	
1 Phase		

T240G Wiring Diagram & Connections*

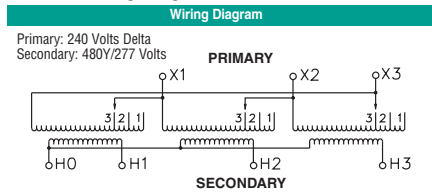

Connections		
Primary Volts	Jumper Taps To	Primary Lines Connect To
240	1	X1, X2, X3
228	2	X1, X2, X3
216	3	X1, X2, X3
Sec. Volts	Secondary Lines Connect To	
480	H1, H2, H3	
277	Between X0 and H1 or H2 or H3	
1 phase		

T240H Wiring Diagram & Connections*

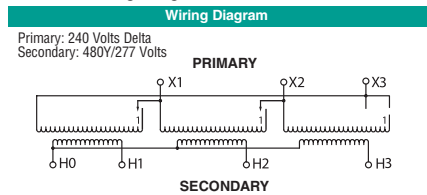

Connections		
Primary Volts	On Each Coil Jumper Taps To	Primary Lines Connect To
240	1	X1, X2, X3
Sec. Volts	Secondary Lines Connect To	
480	H1, H2, H3	
277	Between H0 and H1 or H2 or H3	
1 Phase		

T240I Wiring Diagram & Connections*

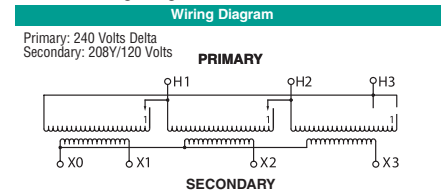

Connections		
Primary Volts	On Each Coil Jumper Taps To	Primary Lines Connect To
240	1	H1, H2, H3
Sec. Volts	Secondary Lines Connect To	
208	X1, X2, X3	
120	Between X0 and X1 or X2 or X3	
1 Phase		

Wiring Diagrams

T460A Wiring Diagram & Connections*

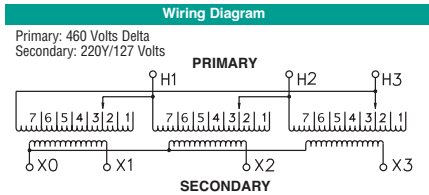

Primary Volts	On Each Coil Jumper Taps To	Primary Lines Connect To
483	1	H1, H2, H3
472	2	H1, H2, H3
460	3	H1, H2, H3
448	4	H1, H2, H3
437	5	H1, H2, H3
425	6	H1, H2, H3
414	7	H1, H2, H3
Sec. Volts	Secondary Lines Connect To	
220	X1, X2, X3	
127	Between X0 and X1 or X2 or X3	
1 Phase		

T480A Wiring Diagram & Connections*

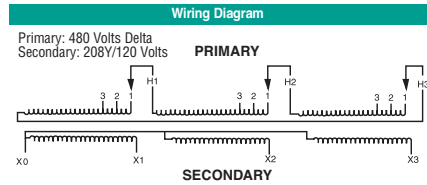

Primary Volts	Jumper Taps To	Primary Lines Connect To
480	1	H1, H2, H3
456	2	H1, H2, H3
432	3	H1, H2, H3
Sec. Volts	Secondary Lines Connect To	
208	X1, X2, X3	
120	Between X0 and X1 or X2 or X3	
1 phase		

T480B Wiring Diagram & Connections*

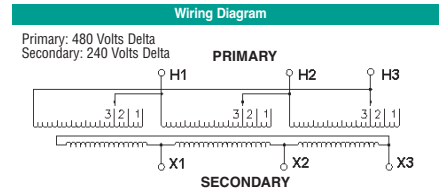

Primary Volts	Jumper Taps To	Primary Lines Connect To
480	1	H1, H2, H3
456	2	H1, H2, H3
432	3	H1, H2, H3
Sec. Volts	Secondary Lines Connect To	
240	X1, X2, X3	

T480C Wiring Diagram & Connections*

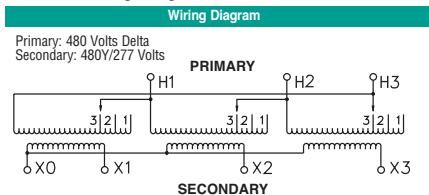

Primary Volts	Jumper Taps To	Primary Lines Connect To
480	1	H1, H2, H3
456	2	H1, H2, H3
432	3	H1, H2, H3
Sec. Volts	Secondary Lines Connect To	
480	X1, X2, X3	
277	Between X0 and X1 or X2 or X3	
1 phase		

T480D Wiring Diagram & Connections*

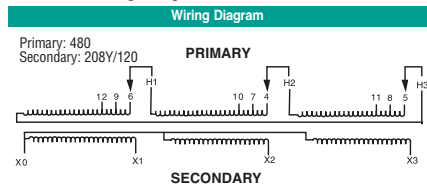

Primary Volts	Interconnect	Supply Lines Connect To
480	H1 & 6 H2 & 4 H3 & 5	H1, H2, H3
456	H1 & 9 H2 & 7 H3 & 8	H1, H2, H3
432	H1 & 12 H2 & 10 H3 & 11	H1, H2, H3
Sec. Volts	Load Lines Connect To	
208	X1, X2, X3	
120	Between X0 and X1 or X2 or X3	
1 Phase		

T480E Wiring Diagram & Connections*

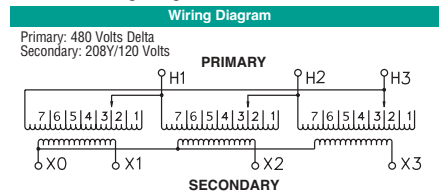

Primary Volts	On Each Coil Jumper Taps To	Primary Lines Connect To
504	1	H1, H2, H3
492	2	H1, H2, H3
480	3	H1, H2, H3
468	4	H1, H2, H3
456	5	H1, H2, H3
444	6	H1, H2, H3
432	7	H1, H2, H3
Sec. Volts	Secondary Lines Connect To	
208	X1, X2, X3	
120	Between X0 and X1 or X2 or X3	
1 Phase		

T480F Wiring Diagram & Connections

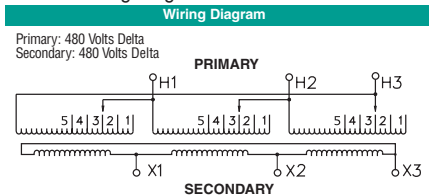

Primary Volts	On Each Coil Jumper Between Taps	Primary Lines Connect To
504	1	H1, H2, H3
492	2	H1, H2, H3
480	3	H1, H2, H3
468	4	H1, H2, H3
456	5	H1, H2, H3
Sec. Volts	Secondary Lines Connect To	
480	X1, X2, X3	

T480G Wiring Diagram & Connections*

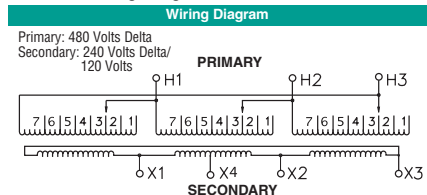

Primary Volts	On Each Coil Jumper Taps To	Primary Lines Connect To
504	1	H1, H2, H3
492	2	H1, H2, H3
480	3	H1, H2, H3
468	4	H1, H2, H3
456	5	H1, H2, H3
444	6	H1, H2, H3
432	7	H1, H2, H3
Sec. Volts	Secondary Lines Connect To	
240	X1, X2, X3	
120	X1 and X4 or X2 and X4	
1 Phase		

T480I Wiring Diagram & Connections*

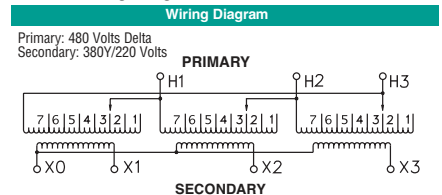

Primary Volts	On Each Coil Jumper Taps To	Primary Lines Connect To
504	1	H1, H2, H3
492	2	H1, H2, H3
480	3	H1, H2, H3
468	4	H1, H2, H3
456	5	H1, H2, H3
444	6	H1, H2, H3
432	7	H1, H2, H3
Sec. Volts	Secondary Lines Connect To	
380	X1, X2, X3	
220	Between X0 and X1 or X2 or X3	
1 Phase		

Wiring Diagrams

T480J Wiring Diagram & Connections*

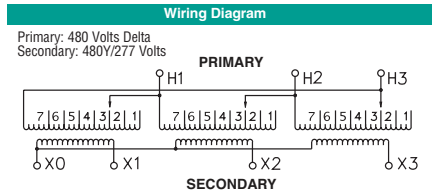

Connections		
Primary Volts	On Each Coil Jumper Taps To	Primary Lines Connect To
504	1	H1, H2, H3
492	2	H1, H2, H3
480	3	H1, H2, H3
468	4	H1, H2, H3
456	5	H1, H2, H3
444	6	H1, H2, H3
432	7	H1, H2, H3
Sec. Volts	Secondary Lines Connect To	
480	X1, X2, X3	
277	Between X0 and X1 or X2 or X3	
1 Phase		

T480K Wiring Diagram & Connections*

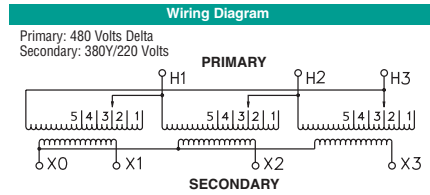

Connections		
Primary Volts	On Each Coil Jumper Taps To	Primary Lines Connect To
504	1	H1, H2, H3
492	2	H1, H2, H3
480	3	H1, H2, H3
468	4	H1, H2, H3
456	5	H1, H2, H3
Sec. Volts	Secondary Lines Connect To	
380	X1, X2, X3	
220	Between X0 and X1 or X2 or X3	
1 Phase		

Group T480L Wiring Diagram & Connections*

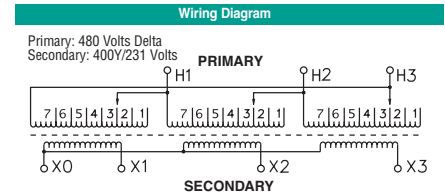

Connections		
Primary Volts	On Each Coil Jumper Between Taps	Primary Lines Connect To
504	1	H1, H2, H3
492	2	H1, H2, H3
480	3	H1, H2, H3
468	4	H1, H2, H3
456	5	H1, H2, H3
444	6	H1, H2, H3
432	7	H1, H2, H3
Sec. Volts	Secondary Lines Connect To	
400	X1, X2, X3	
231	Between X0 and X1 or X2 or X3	
1 Phase		

T480M Wiring Diagram & Connections*

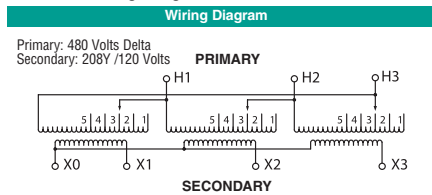

Connections		
Primary Volts	On Each Coil Jumper Taps To	Primary Lines Connect To
504	1	H1, H2, H3
492	2	H1, H2, H3
480	3	H1, H2, H3
468	4	H1, H2, H3
456	5	H1, H2, H3
Sec. Volts	Secondary Lines Connect To	
208	X1, X2, X3	
120	Between X0 and X1 or X2 or X3	
1 Phase		

T480N Wiring Diagram & Connections*

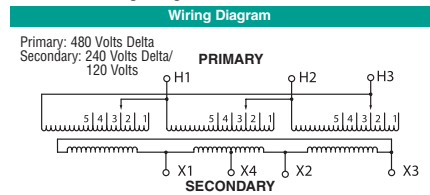

Connections		
Primary Volts	On Each Coil Jumper Taps To	Primary Lines Connect To
504	1	H1, H2, H3
492	2	H1, H2, H3
480	3	H1, H2, H3
468	4	H1, H2, H3
456	5	H1, H2, H3
Sec. Volts	Secondary Lines Connect To	
240	X1, X2, X3	
120	X1 and X4 or X2 and X4	
1 Phase		

T480P Wiring Diagram & Connections*

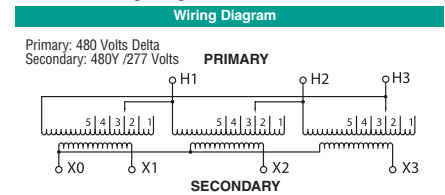

Connections		
Primary Volts	On Each Coil Jumper Taps To	Primary Lines Connect To
504	1	H1, H2, H3
492	2	H1, H2, H3
480	3	H1, H2, H3
468	4	H1, H2, H3
456	5	H1, H2, H3
Sec. Volts	Secondary Lines Connect To	
480	X1, X2, X3	
277	Between X0 and X1 or X2 or X3	
1 Phase		

T480Q Wiring Diagram & Connections*

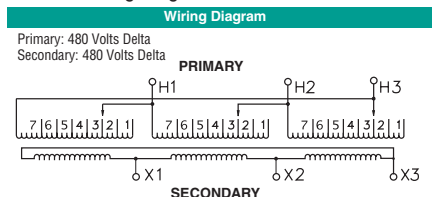

Connections		
Primary Volts	On Each Coil Jumper Taps To	Primary Lines Connect To
504	1	H1, H2, H3
492	2	H1, H2, H3
480	3	H1, H2, H3
468	4	H1, H2, H3
456	5	H1, H2, H3
444	6	H1, H2, H3
432	7	H1, H2, H3
Sec. Volts	Secondary Lines Connect To	
480	X1, X2, X3	

T480R Wiring Diagram & Connections*

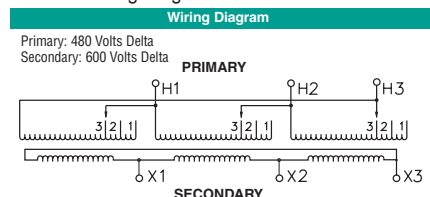

Connections		
Primary Volts	On Each Coil Jumper Taps To	Primary Lines Connect To
480	1	H1, H2, H3
456	2	H1, H2, H3
432	3	H1, H2, H3
Sec. Volts	Secondary Lines Connect To	
600	X1, X2, X3	

T480T Wiring Diagram & Connections*

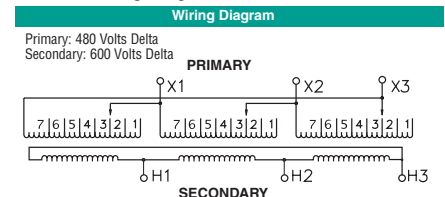

Connections		
Primary Volts	On Each Coil Jumper Taps To	Primary Lines Connect To
504	1	X1, X2, X3
492	2	X1, X2, X3
480	3	X1, X2, X3
468	4	X1, X2, X3
456	5	X1, X2, X3
444	6	X1, X2, X3
432	7	X1, X2, X3
Sec. Volts	Secondary Lines Connect To	
600	H1, H2, H3	

Wiring Diagrams

T480U Wiring Diagram & Connections*

Wiring Diagram

Primary: 480 Volts Delta
Secondary: 400Y/231 Volts

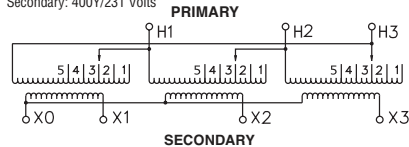

Primary Volts	On Each Coil Jumper Taps To	Primary Lines Connect To
504	1	H1, H2, H3
492	2	H1, H2, H3
480	3	H1, H2, H3
468	4	H1, H2, H3
456	5	H1, H2, H3
Sec. Volts	Secondary Lines Connect To	
400	X1, X2, X3	
231	Between X0 and X1 or X2 or X3	
1 Phase		

T480V Wiring Diagram & Connections*

Wiring Diagram

Primary: 480 Volts Delta
Secondary: 600 Volts Delta

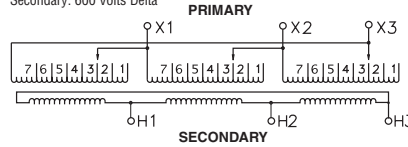

Primary Volts	On Each Coil Jumper Taps To	Primary Lines Connect To
504	1	X1, X2, X3
492	2	X1, X2, X3
480	3	X1, X2, X3
468	4	X1, X2, X3
456	5	X1, X2, X3
Sec. Volts	Secondary Lines Connect To	
600	H1, H2, H3	

T600A Wiring Diagram & Connections*

Wiring Diagram

Primary: 600 Volts Delta
Secondary: 208Y/120 Volts

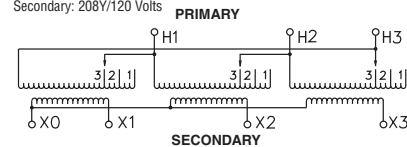

Primary Volts	Jumper Taps To	Primary Lines Connect To
600	1	H1, H2, H3
570	2	H1, H2, H3
540	3	H1, H2, H3
Sec. Volts	Secondary Lines Connect To	
208	X1, X2, X3	
120	Between X0 and X1 or X2 or X3	
1 phase		

T600B Wiring Diagram & Connections*

Wiring Diagram

Primary: 600 Volts
Secondary: 208Y/120 Volts

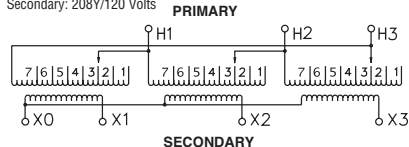

Primary Volts	On Each Coil Jumper Taps To	Primary Lines Between Lines
630	1	H1, H2, H3
615	2	H1, H2, H3
600	3	H1, H2, H3
585	4	H1, H2, H3
570	5	H1, H2, H3
555	6	H1, H2, H3
540	7	H1, H2, H3
Sec. Volts	Secondary Lines Connect To	
208	X1, X2, X3	
120	Between X0 and X1 or X2 or X3	
1 Phase		

T600D Wiring Diagram & Connections*

Wiring Diagram

Primary: 600 Volts
Secondary: 240 Volts Delta/120 Volts

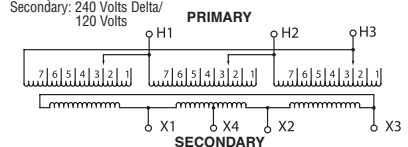

Primary Volts	On Each Coil Jumper Taps To	Primary Lines Between Lines
630	1	H1, H2, H3
615	2	H1, H2, H3
600	3	H1, H2, H3
585	4	H1, H2, H3
570	5	H1, H2, H3
555	6	H1, H2, H3
540	7	H1, H2, H3
Sec. Volts	Secondary Lines Connect To	
240	X1, X2, X3	
120	X1 and X4 or X2 and X4	
1 Phase		

T600E Wiring Diagram & Connections*

Wiring Diagram

Primary: 600 Volts Delta
Secondary: 240 Volts Delta

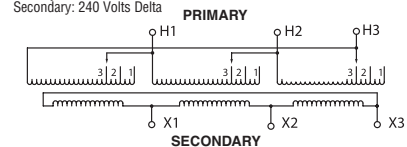

Primary Volts	Jumper Taps To	Primary Lines Connect To
600	1	H1, H2, H3
570	2	H1, H2, H3
540	3	H1, H2, H3
Sec. Volts	Secondary Lines Connect To	
240	X1, X2, X3	

T600F Wiring Diagram & Connections*

Wiring Diagram

Primary: 600 Volts
Secondary: 240 Volts Delta/120 Volts

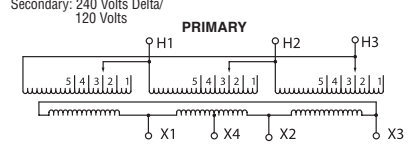

Primary Volts	On Each Coil Jumper Taps To	Primary Lines Between Lines
630	1	H1, H2, H3
615	2	H1, H2, H3
600	3	H1, H2, H3
585	4	H1, H2, H3
570	5	H1, H2, H3
Sec. Volts	Secondary Lines Connect To	
240	X1, X2, X3	
120	Between X0 and X1 or X2 or X3	
1 Phase		

T600G Wiring Diagram & Connections*

Wiring Diagram

Primary: 600 Volts
Secondary: 208Y/120 Volts

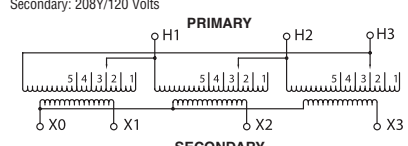

Primary Volts	On Each Coil Jumper Taps To	Primary Lines Between Lines
630	1	H1, H2, H3
615	2	H1, H2, H3
600	3	H1, H2, H3
585	4	H1, H2, H3
570	5	H1, H2, H3
Sec. Volts	Secondary Lines Connect To	
208	X1, X2, X3	
120	Between X0 and X1 or X2 or X3	
1 Phase		

T600H Wiring Diagram & Connections*

Wiring Diagram

Primary: 600 Volts Delta
Secondary: 480Y/277 Volts

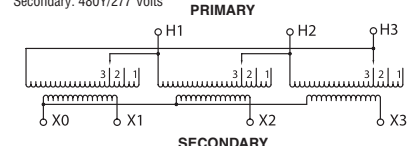

Primary Volts	Jumper Taps To	Primary Lines Connect To
600	1	H1, H2, H3
570	2	H1, H2, H3
540	3	H1, H2, H3
Sec. Volts	Secondary Lines Connect To	
480	X1, X2, X3	
277	Between X0 and X1 or X2 or X3	
1 Phase		

Wiring Diagrams

T600I Wiring Diagram & Connections*

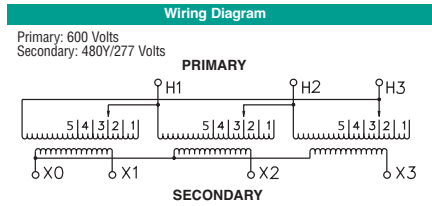

Connections		
Primary Volts	On Each Coil Jumper Taps To	Primary Lines Between Lines
630	1	H1, H2, H3
615	2	H1, H2, H3
600	3	H1, H2, H3
585	4	H1, H2, H3
570	5	H1, H2, H3
Sec. Volts	Secondary Lines Connect To	
480	X1, X2, X3	
277	Between X0 and X1 or X2 or X3	
1 Phase		

T600J Wiring Diagram & Connections*

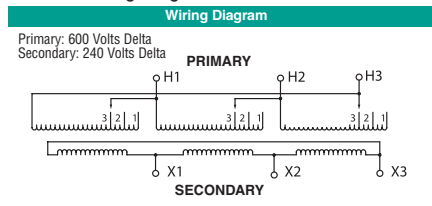

Connections		
Primary Volts	Jumper Taps To	Primary Lines Connect To
600	1	H1, H2, H3
570	2	H1, H2, H3
540	3	H1, H2, H3
Sec. Volts	Secondary Lines Connect To	
480	X1, X2, X3	

T600K Wiring Diagram & Connections*

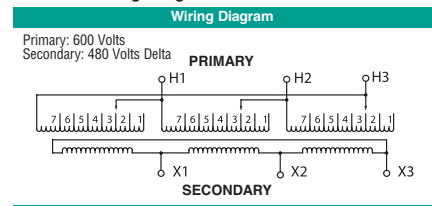

Connections		
Primary Volts	On Each Coil Jumper Taps To	Primary Lines Between Lines
630	1	H1, H2, H3
615	2	H1, H2, H3
600	3	H1, H2, H3
585	4	H1, H2, H3
570	5	H1, H2, H3
555	6	H1, H2, H3
540	7	H1, H2, H3
Sec. Volts	Secondary Lines Connect To	
480	X1, X2, X3	

T600L Wiring Diagram & Connections*

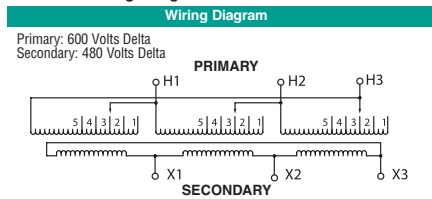

Connections		
Primary Volts	On Each Coil Jumper Taps To	Primary Lines Between Lines
630	1	H1, H2, H3
615	2	H1, H2, H3
600	3	H1, H2, H3
585	4	H1, H2, H3
570	5	H1, H2, H3
Sec. Volts	Secondary Lines Connect To	
480	X1, X2, X3	

T600M Wiring Diagram & Connections*

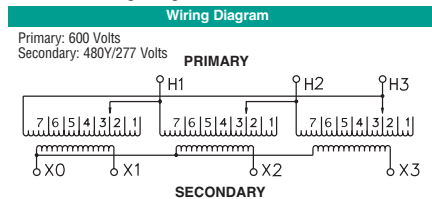

Connections		
Primary Volts	On Each Coil Jumper Taps To	Primary Lines Between Lines
630	1	H1, H2, H3
615	2	H1, H2, H3
600	3	H1, H2, H3
585	4	H1, H2, H3
570	5	H1, H2, H3
555	6	H1, H2, H3
540	7	H1, H2, H3
Sec. Volts	Secondary Lines Connect To	
480	X1, X2, X3	
277	Between X0 and X1 or X2 or X3	
1 Phase		

Series J Typical Performance Data

Dry Type 600 Volt Transformers

60 Hz, 10 kv BIL

Aluminum 3-Phase Dry Type K1 without Electrostatic Shield

KVA	Cont.	Ph.	K	Shield	Temp. Rise	Voltage	Siemens Part Number	Ref. Temp C	No Load Loss Watts	Full Load Loss Watts	Total Loss Watts	IMPEDANCE CHARACTERISTICS			REGULATION Power Factor (PF)		Efficiencies at % of Rated KVA Loads Assumed to be Sinusoidal				Approximate Enclosure Dimensions			Approx. Total Weight	Absol. Peak Inrush rms amps	Practical Max Inrush rms amps ^①	Ref. Drawing	Page		
												IR	IX	IZ (Imp)	X/R	1	0.8	25%	35%*	50%	75%	100%	H (in)						W (in)	D (in)
15	AL	3	1	NO	150	4800-208Y	3F3Y0150D16	170	56	650	706	4.45	1.44	4.68	0.32	4.46	4.44	97.46	97.89	97.11	96.30	95.40	22	19	21	215	195	65	J201	J-4
30	AL	3	1	NO	150	4800-208Y	3F3Y0300D16	170	89	1086	1175	3.82	2.36	4.49	0.62	3.84	4.47	97.89	98.23	97.55	96.84	96.05	25	22	22	330	337	112	J201	J-4
45	AL	3	1	NO	150	4800-208Y	3F3Y0450D16	170	127	1451	1578	3.29	1.86	3.78	0.57	3.31	3.75	98.08	98.40	97.83	97.23	96.55	28	25	23.5	415	210	70	J201	J-4
75	AL	3	1	NO	150	4800-208Y	3F3Y0750D16	170	166	2329	2495	3.39	3.45	4.84	1.02	3.44	4.78	98.36	98.60	97.94	97.26	96.53	32	27	26	585	578	193	J201	J-4
112.5	AL	3	1	NO	150	4800-208Y	3F3Y1120D16	170	195	3319	3514	3.33	5.22	6.19	1.56	3.47	5.82	98.54	98.74	98.05	97.36	96.62	38	29	29	785	523	174	J201	J-4
150	AL	3	1	NO	150	4800-208Y	3F3Y1500D16	170	293	3560	3853	2.52	2.95	3.88	1.17	2.56	3.79	98.61	98.83	98.38	97.90	97.36	42	33	32.5	1035	1223	408	J201	J-4
225	AL	3	1	NO	150	4800-208Y	3F3Y2250D16	170	361	5057	5418	2.41	4.69	5.27	1.95	2.51	4.77	98.78	98.94	98.50	98.03	97.50	46	35	37	1430	1172	391	J201	J-4
300	AL	3	1	NO	150	4800-208Y	3F3Y3000D16	170	444	5803	6247	2.15	5.82	6.20	2.71	2.31	5.26	98.88	99.02	98.65	98.23	97.76	52	35	37	1755	1343	448	J201	J-4
500	AL	3	1	NO	150	4800-208Y	3F3T5000D16	170	798	7438	8236	1.69	5.07	5.35	3.00	1.82	4.44	99.00	99.14	98.87	98.56	98.19	60	48	43.5	2460	2464	821	J201	J-4
750	AL	3	1	NO	150	4800-208Y	3F3T7500D16	170	1023	10385	11408	1.46	3.37	3.67	2.31	1.52	3.20	99.10	99.23	99.01	98.74	98.43	72	52	44	4055	4570	1523	J201	J-4
1000	AL	3	1	NO	150	4800-208Y	3F3T1000D16	170	1237	13082	14319	1.74	4.52	4.84	2.59	1.84	4.14	98.87	98.94	98.79	98.48	98.11	81	66	61	5500	4789	1596	J201	J-4
15	AL	3	1	NO	115	4800-208Y	3F3Y0150D16	135	56	615	671	4.10	1.82	4.48	0.44	4.12	4.37	97.54	97.89	97.28	96.55	95.72	22	19	21	215	199	66	J202	J-5
30	AL	3	1	NO	115	4800-208Y	3F3Y0300D16	135	89	1063	1142	3.68	1.87	4.13	0.51	3.69	4.07	97.92	98.23	97.62	96.94	96.18	25	22	22	330	341	114	J202	J-5
45	AL	3	1	NO	115	4800-208Y	3F3Y0450D16	135	128	1346	1474	2.99	2.26	3.75	0.76	3.02	3.75	98.15	98.40	97.98	97.44	96.83	28	25	23.5	415	485	162	J202	J-5
75	AL	3	1	NO	115	4800-208Y	3F3Y0750D16	135	160	2198	2358	2.99	3.80	4.84	1.27	3.06	4.68	98.42	98.60	98.11	97.53	96.89	32	27	26	585	524	175	J202	J-5
112.5	AL	3	1	NO	115	4800-208Y	3F3Y1120D16	135	181	3284	3465	2.92	5.49	6.22	1.88	3.07	5.66	98.65	98.74	98.25	97.65	97.01	38	29	29	785	451	150	J202	J-5
150	AL	3	1	NO	115	4800-208Y	3F3Y1500D16	135	272	3696	3968	2.46	3.36	4.17	1.36	2.52	3.99	98.68	98.83	98.43	97.95	97.42	42	33	32.5	1250	1122	374	J202	J-5
225	AL	3	1	NO	115	4800-208Y	3F3Y2250D16	135	334	5322	5656	2.37	4.74	5.29	2.00	2.47	4.76	98.83	98.94	98.54	98.07	97.55	46	35	37	1430	1617	539	J202	J-5
300	AL	3	1	NO	115	4800-208Y	3F3Y3000D16	135	411	7070	7481	2.36	6.41	6.83	2.72	2.56	5.79	98.88	99.02	98.57	98.09	97.57	52	35	37	1875	1258	419	J202	J-5
500	AL	3	1	NO	115	4800-208Y	3F3T5000D16	135	738	8138	8876	1.63	5.47	5.71	3.36	1.77	4.64	99.01	99.14	98.90	98.60	98.26	60	48	43.5	2900	2375	792	J202	J-5
750	AL	3	1	NO	115	4800-208Y	3F3T7500D16	135	—	—	—	—	—	—	—	—	—	—	—	—	—	—	—	—	—	—	—	—	J202	J-5
1000	AL	3	1	NO	115	4800-208Y	3F3T1000D16	135	—	—	—	—	—	—	—	—	—	—	—	—	—	—	—	—	—	—	—	—	J202	J-5
15	AL	3	1	NO	80	4800-208Y	3F3Y0150D16	100	60	508	568	3.39	1.99	3.33	0.59	3.41	3.90	97.61	97.89	97.57	97.02	96.35	25	22	22	310	173	58	J203	J-6
30	AL	3	1	NO	80	4800-208Y	3F3Y0300D16	100	91	976	1067	3.17	2.94	4.33	0.93	3.3	4.5	98.12	98.23	97.99	97.39	96.54	28	25	23.5	400	254	85	J203	J-6
45	AL	3	1	NO	80	4800-208Y	3F3Y0450D16	100	139	1109	1248	2.46	2.16	3.27	0.87	2.49	3.26	98.18	98.40	98.18	97.79	97.30	32	27	26	585	499	166	J203	J-6
75	AL	3	1	NO	80	4800-208Y	3F3Y0750D16	100	188	1736	1924	2.31	3.48	4.18	1.50	2.37	3.95	98.44	98.60	98.37	97.97	97.50	38	29	29	775	532	177	J203	J-6
112.5	AL	3	1	NO	80	4800-208Y	3F3Y1120D16	100	243	2470	2713	2.20	4.89	5.36	2.23	2.31	4.72	98.61	98.74	98.49	98.10	97.65	42	33	32.5	1000	591	197	J203	J-6
150	AL	3	1	NO	80	4800-208Y	3F3Y1500D16	100	358	2615	2973	1.74	2.88	3.37	1.65	1.78	3.13	98.63	98.83	98.67	98.40	98.06	46	35	37	1530	1295	432	J203	J-6
225	AL	3	1	NO	80	4800-208Y	3F3Y2250D16	100	400	3924	4324	1.74	4.52	4.84	2.59	1.84	4.14	98.87	98.94	98.79	98.48	98.11	52	35	37	1660	1250	417	J203	J-6
300	AL	3	1	NO	80	4800-208Y	3F3Y3000D16	100	655	3545	4200	1.08	2.57	2.84	2.38	1.1	2.5	98.88	99.02	99.05	98.9	98.63	60	48	43.5	2905	2691	897	J203	J-6
500	AL	3	1	NO	80	4800-208Y	3F3T5000D16	100	878	6072	6950	1.06	5.42	5.59	5.13	1.2	2.5	99.04	99.14	99.11	98.93	98.64	72	52	44	3305	2501	834	J203	J-6
750	AL	3	1	NO	80	4800-208Y	3F3T7500D16	100	—	—	—	—	—	—	—	—	—	—	—	—	—	—	—	—	—	—	—	—	J203	J-6
1000	AL	3	1	NO	80	4800-208Y	3F3T1000D16	100	—	—	—	—	—	—	—	—	—	—	—	—	—	—	—	—	—	—	—	—	J203	J-6

DATA FOR 600 VOLT CLASS PRODUCT LINE

- NOTES
1. Tolerances: watts values = +/- 10%. Impedance values = +/- 7.5%.
 2. Dimensions and weights subject to change without notification.
 3. Transformers conform to applicable ANSI, NEMA and IEEE standards.
 - * 4. Unit will meet or exceed DOE-2016 minimum efficiency.

FOR HEAT OUTPUT (BTU / HR) MULTIPLY TOTAL LOSS BY 3.414

① The sizing of the overcurrent protection for transformer primaries must be approved by the engineer of record based on many factors, including the system coordination required and the preferred use of "absolute" or "practical" values for the application. The minimum breaker size for transformer primaries is typically larger than the "practical" maximum inrush amps by some percentage (usually at least 125% of the "practical" inrush amps).

Series J Typical Performance Data

Dry Type 600 Volt Transformers

60 Hz, 10 kv BIL

Aluminum 3-Phase Dry Type K1 with Electrostatic Shield

KVA	Cond.	Ph.	K	Shield	Temp. Rise	Voltage	Siemens Part Number	Ref. Temp C	No Load Loss Watts	Full Load Loss Watts	Total Loss Watts	IMPEDANCE CHARACTERISTICS			REGULATION (PF)		Efficiencies at % of Rated KVA Loads Assumed to be Sinusoidal					Approximate Enclosure Dimensions			Absol. Peak Inrush rms amps	Practical Max Inrush rms amps ^①	Ref. Drawing	Page	
												IR	IX	IZ (Imp)	X/R	X/S	1	0.8	25%	35%*	50%	75%	100%	H					W
15	AL	3	1	YES	150	4800D-208Y	3F3Y015ESD16	170	66	692	748	4.50	1.65	4.76	0.37	4.60	4.70	97.75	97.90	97.60	96.77	95.37	22	19	21	195	65	J201	J-4
30	AL	3	1	YES	150	4800D-208Y	3F3Y030ESD16	170	89	1191	1280	3.74	2.51	4.51	0.67	3.80	4.60	98.14	98.23	97.94	97.20	96.02	25	22	22	330	112	J201	J-4
45	AL	3	1	YES	150	4800D-208Y	3F3Y045ESD16	170	127	1524	1651	3.54	2.04	3.93	0.88	3.40	4.00	98.30	98.40	98.19	97.56	96.50	28	25	23.5	415	165	J201	J-4
75	AL	3	1	YES	150	4800D-208Y	3F3Y075ESD16	170	154	2503	2657	3.21	3.59	4.82	1.12	3.30	4.90	98.61	98.60	98.37	97.71	96.67	32	27	26	585	190	J201	J-4
112.5	AL	3	1	YES	150	4800D-208Y	3F3Y112ESD16	170	188	3768	3956	3.09	5.32	6.16	1.72	3.30	6.00	98.75	98.74	98.43	97.74	96.69	38	29	29	785	217	J201	J-4
150	AL	3	1	YES	150	4800D-208Y	3F3Y150ESD16	170	271	4076	4348	2.50	3.08	3.95	1.23	2.6	3.9	98.81	98.83	98.63	98.1	97.27	42	33	32.5	1035	248	J201	J-4
225	AL	3	1	YES	150	4800D-208Y	3F3Y225ESD16	170	360	5677	6037	2.32	4.65	5.17	2.00	2.40	4.80	98.94	98.94	98.74	98.27	97.55	46	35	37	1430	306	J201	J-4
300	AL	3	1	YES	150	4800D-208Y	3F3Y300ESD16	170	443	6653	7086	1.97	5.87	6.14	2.89	2.1	5.4	99.02	99.02	98.88	98.48	97.89	52	35	37	1755	348	J201	J-4
500	AL	3	1	YES	150	4800D-208Y	3F3T500ESD16	170	738	8727	9466	1.44	5.17	5.38	3.58	1.6	4.5	99.1	99.14	99.05	98.74	98.27	60	48	43.5	2460	482	J201	J-4
750	AL	3	1	YES	150	4800D-208Y	3F3T750ESD16	170	1023	11343	12366	1.29	3.38	3.68	2.62	1.4	3.2	99.19	99.23	99.17	98.89	98.44	72	52	44	3660	611	J201	J-4
1000	AL	3	1	YES	150	4800D-208Y	3F3T1000ESD16	170	1237	14397	15634	1.19	4.06	4.37	3.42	1.3	3.6	99.25	99.28	99.21	98.95	98.53	81	66	61	5995	811	J201	J-4
15	AL	3	1	YES	115	4800D-208Y	3F3Y015FESD16	135	56	634	690	4.21	1.93	4.63	0.46	4.3	4.7	97.75	97.90	97.62	96.83	95.6	22	19	21	215	66	J202	J-5
30	AL	3	1	YES	115	4800D-208Y	3F3Y030FESD16	135	89	1108	1197	3.61	2.61	4.46	0.72	3.70	4.60	98.14	98.23	97.96	97.26	96.20	25	22	22	330	108	J202	J-5
45	AL	3	1	YES	115	4800D-208Y	3F3Y045FESD16	135	127	1385	1512	3.02	2.45	3.88	0.81	3.10	4.00	98.30	98.40	98.22	97.66	96.82	28	25	23.5	415	159	J202	J-5
75	AL	3	1	YES	115	4800D-208Y	3F3Y075FESD16	135	153	2298	2451	2.94	4.09	5.05	1.39	3.10	5.00	98.60	98.60	98.36	97.74	96.83	32	27	26	585	169	J202	J-5
112.5	AL	3	1	YES	115	4800D-208Y	3F3Y112FESD16	135	181	3544	3724	2.97	6.76	7.49	2.28	3.20	7.00	98.75	98.74	98.40	97.72	96.77	38	29	29	785	149	J202	J-5
150	AL	3	1	YES	115	4800D-208Y	3F3Y150FESD16	135	338	3029	3367	1.91	2.47	3.12	1.30	1.9	3.1	98.72	98.83	98.74	98.4	97.85	42	33	32.5	1250	172	J202	J-5
225	AL	3	1	YES	115	4800D-208Y	3F3Y225FESD16	135	333	5495	5828	2.26	4.77	5.24	2.11	2.4	4.9	98.94	98.94	98.72	98.22	97.51	46	35	37	1430	167	J202	J-5
300	AL	3	1	YES	115	4800D-208Y	3F3Y300FESD16	135	410	7030	7441	1.93	6.30	6.59	3.27	2.1	5.6	99.04	99.04	98.86	98.43	97.82	52	35	37	1875	218	J202	J-5
500	AL	3	1	YES	115	4800D-208Y	3F3T500FESD16	135	738	8086	8824	1.41	5.33	5.53	3.78	1.6	4.5	99.1	99.14	99.04	98.75	98.3	60	48	43.5	2835	375	J202	J-5
750	AL	3	1	YES	115	4800D-208Y	3F3T750FESD16	135	1023	11343	12366	1.29	3.38	3.68	2.62	1.4	3.2	99.19	99.23	99.17	98.89	98.44	72	52	44	3660	611	J202	J-5
1000	AL	3	1	YES	115	4800D-208Y	3F3T1000FESD16	135	1237	14397	15634	1.19	4.06	4.37	3.42	1.3	3.6	99.25	99.28	99.21	98.95	98.53	81	66	61	5995	811	J202	J-5
15	AL	3	1	YES	80	4800D-208Y	3F3Y015BESD16	100	60	508	568	3.39	1.99	3.93	0.59	3.41	3.90	97.61	97.90	97.57	97.02	96.35	25	22	22	310	58	J203	J-6
30	AL	3	1	YES	80	4800D-208Y	3F3Y030BESD16	100	92	927	1019	3.12	2.86	4.23	0.82	3.16	4.22	98.03	98.23	97.87	97.32	96.68	28	25	23.5	400	85	J203	J-6
45	AL	3	1	YES	80	4800D-208Y	3F3Y045BESD16	100	138	1164	1303	2.45	2.39	3.43	0.88	2.5	3.5	98.25	98.40	98.29	97.87	97.25	32	27	26	585	166	J203	J-6
75	AL	3	1	YES	80	4800D-208Y	3F3Y075BESD16	100	188	1765	1953	2.23	3.69	4.32	1.66	2.30	4.20	98.51	98.60	98.47	98.05	97.46	38	29	29	775	175	J203	J-6
112.5	AL	3	1	YES	80	4800D-208Y	3F3Y112BESD16	100	243	2477	2720	2.03	5.04	5.45	2.48	2.2	4.9	98.68	98.74	98.62	98.23	97.67	42	33	32.5	1000	197	J203	J-6
150	AL	3	1	YES	80	4800D-208Y	3F3Y150BESD16	100	357	2629	2987	1.62	3.07	3.50	1.89	1.7	3.3	98.69	98.83	98.77	98.5	98.08	46	35	37	1530	236	J203	J-6
225	AL	3	1	YES	80	4800D-208Y	3F3Y225BESD16	100	399	3925	4324	1.59	4.56	4.91	2.87	1.7	4.2	98.93	98.94	98.89	98.58	98.15	52	35	37	1660	241	J203	J-6
300	AL	3	1	YES	80	4800D-208Y	3F3Y300BESD16	100	535	4417	4952	1.31	4.94	5.15	3.78	1.4	4.2	98.98	99.02	98.9	98.76	98.39	60	48	43.5	2905	269	J203	J-6
500	AL	3	1	YES	80	4800D-208Y	3F3T500BESD16	100	878	6072	6950	1.06	5.42	5.59	5.13	1.2	2.5	99.04	99.14	99.11	98.93	98.64	72	52	44	3270	384	J203	J-6
750	AL	3	1	YES	80	4800D-208Y	3F3T750BESD16	100	1023	11343	12366	1.29	3.38	3.68	2.62	1.4	3.2	99.19	99.23	99.17	98.89	98.44	72	52	44	3660	611	J203	J-6
1000	AL	3	1	YES	80	4800D-208Y	3F3T1000BESD16	100	1237	14397	15634	1.19	4.06	4.37	3.42	1.3	3.6	99.25	99.28	99.21	98.95	98.53	81	66	61	5995	811	J203	J-6

DATA FOR 600 VOLT CLASS PRODUCT LINE

- NOTES
- Tolerances: watts values = +/- 10%. Impedance values = +/- 7.5%.
 - Dimensions and weights subject to change without notification.
 - Transformers conform to applicable ANSI, NEMA and IEEE standards.
 - * 4. Unit will meet or exceed DOE-2016 minimum efficiency.

FOR HEAT OUTPUT (BTU / HR) MULTIPLY TOTAL LOSS BY 3.414

① The sizing of the overcurrent protection for transformer primaries must be approved by the engineer of record based on many factors, including the system coordination required and the preferred use of "absolute" or "practical" values for the application. The minimum breaker size for transformer primaries is typically larger than the "practical" maximum inrush amps by some percentage (usually at least 125% of the "practical" inrush value).

Series J Typical Performance Data

Dry Type 600 Volt Transformers

60 Hz, 10 kv BIL

Aluminum 3-Phase Dry Type K4 with Electrostatic Shield

KVA	Cont.	Ph.	K	Shield	Temp. Rise	Voltage	Siemens Part Number	Ref. Temp C	No Load Loss Watts	Full Load Loss Watts	Total Loss Watts	IMPEDANCE CHARACTERISTICS			REGULATION Power Factor (PF)		Efficiencies at % of Rated KVA Loads Assumed to be Sinusoidal				Approximate Enclosure Dimensions			Approx. Total Weight	Absol. Peak Inrush rms amps	Practical Max Inrush rms amps [ⓐ]	Ref. Drawing	Page		
												IR	IX	IZ (Imp)	X/R	1	0.8	25%	35%*	50%	75%	100%	H (in)						W (in)	D (in)
15	AL	3	4	YES	150	4800-208Y	3F3Y015K4BD16	170	605	605	665	3.28	2.14	3.92	0.65	3.40	97.75	97.90	97.78	97.18	96.25	22	19	21	210	193	64	J209	J-7	
30	AL	3	4	YES	150	4800-208Y	3F3Y030K4BD16	170	89	1108	1197	3.62	2.61	4.46	0.72	3.70	98.14	98.23	97.96	97.26	96.20	25	22	22	310	323	108	J209	J-7	
45	AL	3	4	YES	150	4800-208Y	3F3Y045K4BD16	170	127	1385	1512	3.02	2.45	3.88	0.81	3.10	98.60	98.40	98.22	97.66	96.82	28	25	23.5	400	477	159	J209	J-7	
75	AL	3	4	YES	150	4800-208Y	3F3Y075K4BD16	170	153	2298	2451	3.04	4.09	5.03	1.39	3.10	98.60	98.60	98.36	97.74	96.83	32	27	26	585	508	169	J209	J-7	
112.5	AL	3	4	YES	150	4800-208Y	3F3Y112K4BD16	170	188	3768	3956	3.09	5.32	6.16	1.72	3.30	98.75	98.74	98.43	97.74	96.69	38	29	29	775	517	172	J209	J-7	
150	AL	3	4	YES	150	4800-208Y	3F3Y150K4BD16	170	271	4672	4944	2.43	3.39	4.17	1.40	2.50	4.10	98.73	98.83	98.48	97.86	96.94	42	33	32.5	1000	1096	365	J209	J-7
225	AL	3	4	YES	150	4800-208Y	3F3Y225K4BD16	170	382	6207	6589	2.13	4.31	4.77	2.02	2.20	4.40	98.82	98.94	98.59	98.04	97.21	46	35	37	1315	1209	403	J209	J-7
300	AL	3	4	YES	150	4800-208Y	3F3Y300K4BD16	170	410	8669	9079	1.15	5.90	6.27	2.35	2.3	5.6	98.93	99.02	98.62	98.03	97.16	52	35	37	1660	1298	433	J209	J-7
500	AL	3	4	YES	150	4800-208Y	3F3T500K4BD16	170	1011	7081	8092	0.80	3.16	3.35	2.97	0.80	2.60	98.94	99.14	99.06	98.89	96.62	60	48	43.5	2645	3425	1142	J209	J-7
750	AL	3	4	YES	150	4800-208Y	3F3T750K4BD16	170	—	—	—	—	—	—	—	—	—	—	—	—	—	—	—	—	—	—	—	—	J209	J-7
1000	AL	3	4	YES	150	4800-208Y	3F3T1000K4BD16	170	—	—	—	—	—	—	—	—	—	—	—	—	—	—	—	—	—	—	—	—	J209	J-7
15	AL	3	4	YES	115	4800-208Y	3F3Y015K4FD16	135	60	564	613	3.28	2.29	4.00	0.70	3.4	97.75	97.90	97.78	97.18	96.24	—	19	21	210	182	61	J210	J-8	
30	AL	3	4	YES	115	4800-208Y	3F3Y030K4FD16	135	91	1112	1203	3.12	2.33	3.88	0.75	3.20	98.11	98.23	97.95	97.28	96.31	25	22	22	340	312	104	J210	J-8	
45	AL	3	4	YES	115	4800-208Y	3F3Y045K4FD16	135	138	1239	1377	2.51	2.18	3.33	0.87	2.60	98.27	98.40	98.30	97.87	97.19	28	25	23.5	430	552	184	J210	J-8	
75	AL	3	4	YES	115	4800-208Y	3F3Y075K4FD16	135	153	2298	2451	2.94	4.09	5.05	1.39	3.10	98.60	98.60	98.36	97.74	96.83	32	27	26	615	508	169	J210	J-8	
112.5	AL	3	4	YES	115	4800-208Y	3F3Y112K4FD16	135	206	3364	3570	2.57	5.10	5.74	1.98	2.70	5.40	98.68	98.74	98.40	97.77	96.90	38	29	29	860	630	210	J210	J-8
150	AL	3	4	YES	115	4800-208Y	3F3Y150K4FD16	135	357	3206	3563	1.66	2.68	3.18	1.62	1.70	3.00	98.64	98.83	98.67	98.32	97.77	42	33	32.5	1165	1435	478	J210	J-8
225	AL	3	4	YES	115	4800-208Y	3F3Y225K4FD16	135	400	5410	5809	1.91	3.84	4.29	2.01	2	2	98.83	98.94	98.67	98.2	97.53	46	35	37	1440	1480	493	J210	J-8
300	AL	3	4	YES	115	4800-208Y	3F3Y300K4FD16	135	655	4769	5424	1.16	2.74	2.97	2.35	1.2	2.7	98.82	99.02	98.91	98.67	98.28	52	35	37	2010	2726	909	J210	J-8
500	AL	3	4	YES	115	4800-208Y	3F3T500K4FD16	135	1011	6353	7364	0.87	2.25	2.36	2.60	0.9	2.1	98.94	99.14	99.07	98.89	96.57	60	48	43.5	2660	4309	1436	J210	J-8
750	AL	3	4	YES	115	4800-208Y	3F3T750K4FD16	135	—	—	—	—	—	—	—	—	—	—	—	—	—	—	—	—	—	—	—	—	J210	J-8
1000	AL	3	4	YES	115	4800-208Y	3F3T1000K4FD16	135	—	—	—	—	—	—	—	—	—	—	—	—	—	—	—	—	—	—	—	—	J210	J-8
15	AL	3	4	YES	80	4800-208Y	3F3Y015K4BD16	100	91	214	305	1.25	0.84	1.51	0.67	1.2	1.5	97.33	97.90	98.19	98.26	98.1	25	22	22	340	404	135	J211	J-9
30	AL	3	4	YES	80	4800-208Y	3F3Y030K4BD16	100	127	585	712	1.71	1.25	2.12	0.73	1.7	2.1	97.93	98.23	98.33	98.14	97.75	28	25	23.5	425	543	181	J211	J-9
45	AL	3	4	YES	80	4800-208Y	3F3Y045K4BD16	100	138	1164	1303	2.50	2.44	3.50	0.98	2.6	3.6	98.25	98.40	98.28	97.85	97.21	32	27	26	475	606	202	J211	J-9
75	AL	3	4	YES	80	4800-208Y	3F3Y075K4BD16	100	188	1765	1953	2.23	3.69	4.32	1.66	2.3	4.2	98.51	98.60	98.47	98.05	97.46	38	29	29	660	525	175	J211	J-9
112.5	AL	3	4	YES	80	4800-208Y	3F3Y112K4BD16	100	271	2350	2621	1.74	2.87	3.36	1.64	1.8	3.2	98.61	98.74	98.61	98.26	97.76	42	33	32.5	885	969	323	J211	J-9
150	AL	3	4	YES	80	4800-208Y	3F3Y150K4BD16	100	357	2823	3180	1.51	3.18	3.56	2.11	1.6	3.2	98.66	98.83	98.71	98.41	97.6	46	35	37	1155	1249	416	J211	J-9
225	AL	3	4	YES	80	4800-208Y	3F3Y225K4BD16	100	400	4320	4719	1.53	4.60	4.93	3.00	1.60	4.20	98.89	98.94	98.80	98.44	97.96	52	35	37	1530	1243	414	J211	J-9
300	AL	3	4	YES	80	4800-208Y	3F3Y300K4BD16	100	655	4719	5374	1.12	3.30	3.55	2.95	1.20	3.00	98.82	99.02	98.93	98.72	98.39	60	48	43.5	2385	2357	786	J211	J-9
500	AL	3	4	YES	80	4800-208Y	3F3T500K4BD16	100	1011	5930	6941	0.79	2.71	2.77	3.44	0.8	2.3	98.94	99.14	99.07	98.91	98.64	72	52	44	3315	3663	1221	J211	J-9
750	AL	3	4	YES	80	4800-208Y	3F3T750K4BD16	100	—	—	—	—	—	—	—	—	—	—	—	—	—	—	—	—	—	—	—	—	J211	J-9
1000	AL	3	4	YES	80	4800-208Y	3F3T1000K4BD16	100	—	—	—	—	—	—	—	—	—	—	—	—	—	—	—	—	—	—	—	—	J211	J-9

DATA FOR 600 VOLT CLASS PRODUCT LINE

- 1. Tolerances: watts values = +/- 10%. Impedance values = +/- 7.5%.
- 2. Dimensions and weights subject to change without notification.
- 3. Transformers conform to applicable ANSI, NEMA and IEEE standards.
- * 4. Unit will meet or exceed DOE-2016 minimum efficiency.

FOR HEAT OUTPUT (BTU / HR) MULTIPLY TOTAL LOSS BY 3.414

ⓐ The sizing of the overcurrent protection for transformer primaries must be approved by the engineer of record based on many factors, including the system coordination required and the preferred use of "absolute" or "practical" values for the application. The minimum breaker size for transformer primaries is typically larger than the "practical" maximum inrush amps by some percentage (usually at least 125% of the "practical" inrush value).

Series J Typical Performance Data

Dry Type 600 Volt Transformers

60 Hz, 10 kv BIL

Aluminum 3-Phase Dry Type K13 with Electrostatic Shield

KVA	Cond.	Ph.	K	Shield	Temp. Rise	Voltage	Siemens Part Number	Ref. Temp C	No Load Loss Watts	Full Load Loss Watts	Total Loss Watts	IMPEDANCE CHARACTERISTICS			REGULATION (PF)		Efficiencies at % of Rated KVA Loads Assumed to be Sinusoidal					Approximate Enclosure Dimensions			Absol. Peak Inrush rms amps	Practical Max Inrush rms amps [Ⓞ]	Ref. Drawing	
												IR	IX	IZ (Imp)	X/R	1	0.8	25%	35%*	50%	75%	100%	H (in)	W (in)				D (in)
15	AL	3	13	YES	150	4800-208Y	3F3V015K13D16	170	60	723	782	3.44	1.59	3.79	0.46	3.50	97.61	97.90	97.48	96.68	95.43	25	22	22	400	68	J212	J-10
30	AL	3	13	YES	150	4800-208Y	3F3V030K13D16	170	91	1446	1538	3.35	3.02	4.52	0.90	3.50	97.97	98.23	97.66	96.80	95.56	28	25	23.5	775	90	J212	J-10
45	AL	3	13	YES	150	4800-208Y	3F3V045K13D16	170	138	1814	1953	2.73	2.02	3.40	0.74	2.80	98.08	98.40	97.91	97.20	96.14	32	27	26	1530	180	J212	J-10
75	AL	3	13	YES	150	4800-208Y	3F3V075K13D16	170	188	2717	2905	2.44	2.64	3.60	1.08	2.50	98.31	98.60	98.03	97.29	96.20	38	29	29	310	212	J212	J-10
112.5	AL	3	13	YES	150	4800-208Y	3F3Y112K13D16	170	243	2477	2720	2.03	5.05	5.45	2.20	4.90	98.68	98.74	98.62	98.23	97.67	42	33	32.5	585	195	J212	J-10
150	AL	3	13	YES	150	4800-208Y	3F3Y150K13D16	170	357	2629	2987	1.62	3.06	3.50	1.88	3.30	98.69	98.83	98.77	98.50	98.08	46	35	37	1000	424	J212	J-10
225	AL	3	13	YES	150	4800-208Y	3F3Y225K13D16	170	431	7590	8022	1.80	3.77	4.18	2.09	1.90	98.94	98.94	98.77	98.50	98.71	52	35	37	1660	498	J212	J-10
300	AL	3	13	YES	150	4800-208Y	3F3Y300K13D16	170	655	7985	8640	1.24	3.16	3.39	2.54	1.30	98.63	99.02	98.52	98.05	97.38	60	48	43.5	2460	815	J212	J-10
500	AL	3	13	YES	150	4800-208Y	3F3T500K13D16	170	1011	11238	12249	0.90	2.48	2.64	2.75	0.90	98.76	99.14	98.69	98.28	97.67	72	52	44	4055	1313	J212	J-10
750	AL	3	13	YES	150	4800-208Y	3F3T750K13D16	170	—	—	—	—	—	—	—	—	99.23	—	—	—	—	81	66	61	6010	—	J212	J-10
1000	AL	3	13	YES	150	4800-208Y	3F3T1000K13D16	170	—	—	—	—	—	—	—	—	—	—	—	—	—	—	—	—	0	—	J212	J-10
15	AL	3	4	YES	115	4800-208Y	3F3V015K13FD16	135	60	554	613	3.28	2.29	4.00	0.70	4.1	97.75	97.90	97.78	97.18	96.24	—	19	21	220	182	J213	J-11
30	AL	3	4	YES	115	4800-208Y	3F3V030K13FD16	135	91	1112	1203	3.12	2.33	3.88	0.75	3.20	98.11	98.23	97.95	97.28	96.31	25	22	22	340	312	J213	J-11
45	AL	3	4	YES	115	4800-208Y	3F3V045K13FD16	135	138	1239	1377	2.51	2.18	3.33	0.87	2.60	98.27	98.40	98.30	97.87	97.19	28	25	23.5	430	552	J213	J-11
75	AL	3	4	YES	115	4800-208Y	3F3V075K13FD16	135	153	2298	2451	2.94	4.09	5.05	1.39	3.10	98.60	98.60	98.36	97.74	96.83	32	27	26	615	508	J213	J-11
112.5	AL	3	4	YES	115	4800-208Y	3F3Y112K13FD16	135	206	3364	3570	2.57	5.10	5.74	1.98	2.70	98.68	98.74	98.40	97.77	96.90	38	29	29	860	630	J213	J-11
150	AL	3	4	YES	115	4800-208Y	3F3Y150K13FD16	135	357	3206	3563	1.66	2.68	3.18	1.62	1.70	98.64	98.83	98.67	98.32	97.77	42	33	32.5	1165	1435	J213	J-11
225	AL	3	4	YES	115	4800-208Y	3F3Y225K13FD16	135	400	5410	5809	1.91	3.84	4.29	2.01	2	98.83	98.94	98.67	98.2	97.53	46	35	37	1440	1480	J213	J-11
300	AL	3	4	YES	115	4800-208Y	3F3Y300K13FD16	135	655	4769	5424	1.16	2.74	2.97	2.35	1.2	98.82	99.02	98.91	98.67	98.28	52	35	37	2010	2726	J213	J-11
500	AL	3	4	YES	115	4800-208Y	3F3T500K13FD16	135	1011	6353	7364	0.87	2.25	2.36	2.60	0.9	98.94	99.14	99.07	98.89	98.57	60	48	43.5	2660	4309	J213	J-11
750	AL	3	4	YES	115	4800-208Y	3F3T750K13FD16	135	—	—	—	—	—	—	—	—	99.23	—	—	—	—	—	—	—	—	—	J213	J-11
15	AL	3	13	YES	80	4800-208Y	3F3V015K13BD16	100	60	612	671	3.26	2.16	3.91	0.66	3.3	97.61	97.90	97.50	96.8	95.82	25	22	22	340	167	J228	J-12
30	AL	3	13	YES	80	4800-208Y	3F3V030K13BD16	100	127	723	850	1.81	1.61	2.43	0.89	1.8	97.83	98.23	98.12	97.81	97.29	28	25	23.5	425	483	J228	J-12
45	AL	3	13	YES	80	4800-208Y	3F3V045K13BD16	100	142	1337	1479	2.13	2.49	3.29	1.17	2.2	98.13	98.40	98.09	97.57	96.84	32	27	26	615	434	J228	J-12
75	AL	3	13	YES	80	4800-208Y	3F3V075K13BD16	100	174	2691	2865	2.49	4.33	5.00	1.74	2.60	98.33	98.60	97.98	97.24	96.27	38	29	29	850	443	J228	J-12
112.5	AL	3	13	YES	80	4800-208Y	3F3Y112K13BD16	100	257	2138	2496	1.15	2.00	2.33	1.74	1.2	98.34	98.74	98.53	98.27	97.85	42	33	32.5	1215	1468	J228	J-12
150	AL	3	13	YES	80	4800-208Y	3F3Y150K13BD16	100	399	3400	3799	1.21	2.82	2.98	2.33	1.2	98.46	98.83	98.47	98.09	97.56	46	35	37	1390	1354	J228	J-12
225	AL	3	13	YES	80	4800-208Y	3F3Y225K13BD16	100	655	3754	4408	0.75	2.64	2.77	3.53	0.80	98.48	98.94	98.66	98.45	98.10	52	35	37	2010	2318	J228	J-12
300	AL	3	13	YES	80	4800-208Y	3F3Y300K13BD16	100	780	4368	5147	0.65	2.56	2.67	3.95	0.70	98.63	99.02	98.80	98.62	98.32	60	48	43.5	2510	2619	J228	J-12
500	AL	3	13	YES	80	4800-208Y	3F3T500K13BD16	100	1064	8492	9556	0.73	2.75	2.89	3.79	0.8	98.79	99.14	98.82	98.54	98.13	72	52	44	6030	3860	J228	J-12

DATA FOR 600 VOLT CLASS PRODUCT LINE

- NOTES
1. Tolerances: watts values = +/- 10%. Impedance values = +/- 7.5%.
 2. Dimensions and weights subject to change without notification.
 3. Transformers conform to applicable ANSI, NEMA and IEEE standards.
 - * 4. Unit will meet or exceed DOE-2016 minimum efficiency.

FOR HEAT OUTPUT (BTU / HR) MULTIPLY TOTAL LOSS BY 3.414

[Ⓞ] The sizing of the overcurrent protection for transformer primaries must be approved by the engineer of record based on many factors, including the system coordination required and the preferred use of "absolute" or "practical" values for the application. The minimum breaker size for transformer primaries is typically larger than the "practical" maximum inrush amps by some percentage (usually at least 125% of the "practical" inrush value).

Series J Typical Performance Data

Dry Type 600 Volt Transformers

60 Hz, 10 kv BIL

Series J Typical Heat Loss Data for Series J TP1 Single Phase Transformers

KVA	Cond.	Ph.	K	Shield	Temp. Rise	Voltage	Siemens Part Number	Ref. Temp C	No Load Loss Watts	Full Load Loss Watts	Total Loss Watts	IMPEDANCE CHARACTERISTICS			REGULATION Power Factor (PF)		Efficiencies at % of Rated KVA Loads Assumed to be Sinusoidal				Approximate Enclosure Dimensions			Absol. Peak Inrush rms amps	Practical Max Inrush rms amps ^④			
												IR	IX	IZ (Imp)	X/R	1	0.8	25%	35%*	50%	75%	100%	H (in)			W (in)	D (in)	Approx. Total Weight
15	AL	1	1	NO	150	480-240/120	1D1Y015TP1	170	70	650	720	4.33	2.49	5.00	0.58	4.36	4.97	97.13	97.70	96.99	96.27	95.42	27	15	15	180	470	160
25	AL	1	1	NO	150	480-240/120	1D1Y025TP1	170	100	900	1000	3.60	4.02	5.40	1.12	3.68	5.30	97.56	98.00	97.47	96.87	96.15	29	17	17	250	580	195
37	AL	1	1	NO	150	480-240/120	1D1Y037TP1	170	125	1275	1400	3.45	4.54	5.70	1.32	3.54	5.42	97.84	98.20	97.66	97.05	96.35	31	20	18	315	690	230
50	AL	1	1	NO	150	480-240/120	1D1Y050TP1	170	175	1425	1600	2.85	5.51	6.20	1.93	2.93	4.76	97.93	98.30	97.92	97.46	96.90	32	22	20	400	1210	405
75	AL	1	1	NO	150	480-240/120	1D1Y075TP1	170	210	2425	2635	3.23	5.52	6.40	1.71	3.36	5.64	98.11	98.50	97.87	97.28	96.61	34	22	22	520	1230	410
100	AL	1	1	NO	150	480-240/120	1D1Y100TP1	170	265	2750	3015	2.75	5.44	6.10	1.98	2.92	5.78	98.28	98.60	98.13	97.64	97.07	36	22	24	625	1490	500
167	AL	1	1	NO	150	480-240/120	1D1Y167TP1	170	425	3825	4250	2.29	—	—	—	2.40	4.73	98.43	98.70	98.37	97.98	97.52	46	35	30	2350	785	

- NOTES
1. Tolerances: watts values = +/- 10%. Impedance values = +/- 7.5%.
 2. Dimensions and weights subject to change without notification.
 3. Transformers conform to applicable ANSI, NEMA and IEEE standards.
 - * 4. Unit will meet or exceed DOE-2016 minimum efficiency.

DATA FOR 600 VOLT CLASS PRODUCT LINE

FOR HEAT OUTPUT (BTU / HR) MULTIPLY TOTAL LOSS BY 3.414

Explanation of Inrush Current Calculations

Inrush current was calculated current by the method shown in IEEE Publication 389-1990. This calculation is based upon maximum residual magnetism of the core structure and assumes zero system impedance and no drop in source voltage during the time inrush current flows. The value is a theoretical maximum.

In the practical world, the transformer winding being energized has impedance, the voltage source has impedance, and this results in a drop in voltage while inrush current

flows. We also make a second inrush current calculation based upon this reduced source voltage typical of what would be seen in a practical distribution system.

The first and larger of the two numbers listed for inrush current is the theoretical maximum. The second is a typical value of inrush current that will be experienced by the transformer in a typical installation.

Approximate duration is .1 seconds.

④ The sizing of the overcurrent protection for transformer primaries must be approved by the engineer of record based on many factors, including the system coordination required and the preferred use of "absolute" or "practical" values for the application. The minimum breaker size for transformer primaries is typically larger than the "practical" maximum inrush amps by some percentage (usually at least 125% of the "practical" inrush value).

Series J Typical Performance Data

Notes

Siemens Industry, Inc.
5400 Triangle Parkway
Norcross, GA 30092

1-800-333-7421
info.us@siemens.com

Order No. PDPC-TRSUP-0120

© 2018 Siemens Industry, Inc.

usa.siemens.com/distribution-transformers

The technical data presented in this document is based on an actual case or on as-designed parameters, and therefore should not be relied upon for any specific application and does not constitute a performance guarantee for any projects. Actual results are dependent on variable conditions. Accordingly, Siemens does not make representations, warranties, or assurances as to the accuracy, currency or completeness of the content contained herein. If requested, we will provide specific technical data or specifications with respect to any customer's particular applications. Our company is constantly involved in engineering and development. For that reason, we reserve the right to modify, at any time, the technology and product specifications contained herein.

