

SIEMENS

RUGGEDCOM RS416

Installation Guide

Preface

Introduction

1

Installing Device

2

Communication Ports

3

Technical Specifications

4

Dimension Drawings

5

Certification

6

Copyright © 2015 Siemens Canada Ltd.

All rights reserved. Dissemination or reproduction of this document, or evaluation and communication of its contents, is not authorized except where expressly permitted. Violations are liable for damages. All rights reserved, particularly for the purposes of patent application or trademark registration.

This document contains proprietary information, which is protected by copyright. All rights are reserved. No part of this document may be photocopied, reproduced or translated to another language without the prior written consent of Siemens Canada Ltd..

Disclaimer Of Liability

Siemens has verified the contents of this manual against the hardware and/or software described. However, deviations between the product and the documentation may exist.

Siemens shall not be liable for any errors or omissions contained herein or for consequential damages in connection with the furnishing, performance, or use of this material.

The information given in this document is reviewed regularly and any necessary corrections will be included in subsequent editions. We appreciate any suggested improvements. We reserve the right to make technical improvements without notice.

Registered Trademarks

ROX™, Rugged Operating System On Linux™, CrossBow™ and ELAN™ are trademarks of Siemens Canada Ltd. ROS® is a registered trademark of Siemens Canada Ltd.

Other designations in this manual might be trademarks whose use by third parties for their own purposes would infringe the rights of the owner.

Third Party Copyrights

Siemens recognizes the following third party copyrights:

- Copyright © 2004 GoAhead Software, Inc. All Rights Reserved.

Security Information

Siemens provides products and solutions with industrial security functions that support the secure operation of plants, machines, equipment and/or networks. They are important components in a holistic industrial security concept. With this in mind, Siemens' products and solutions undergo continuous development. Siemens recommends strongly that you regularly check for product updates.

For the secure operation of Siemens products and solutions, it is necessary to take suitable preventive action (e.g. cell protection concept) and integrate each component into a holistic, state-of-the-art industrial security concept. Third-party products that may be in use should also be considered. For more information about industrial security, visit <http://www.siemens.com/industrialsecurity>.

To stay informed about product updates as they occur, sign up for a product-specific newsletter. For more information, visit <http://support.automation.siemens.com>.

Warranty

Siemens warrants this product for a period of five (5) years from the date of purchase, conditional upon the return to factory for maintenance during the warranty term. This product contains no user-serviceable parts. Attempted service by unauthorized personnel shall render all warranties null and void. The warranties set forth in this article are exclusive and are in lieu of all other warranties, performance guarantees and conditions whether written or oral, statutory, express or implied (including all warranties and conditions of merchantability and fitness for a particular purpose, and all warranties and conditions arising from course of dealing or usage or trade). Correction of nonconformities in the manner and for the period of time provided above shall constitute the Seller's sole liability and the Customer's exclusive remedy for defective or nonconforming goods or services whether claims of the Customer are based in contract (including fundamental breach), in tort (including negligence and strict liability) or otherwise.

For warranty details, visit www.siemens.com/ruggedcom or contact a Siemens customer service representative.

Contacting Siemens

Address

Siemens Canada Ltd.
Industry Sector
300 Applewood Crescent
Concord, Ontario
Canada, L4K 5C7

Telephone

Toll-free: 1 888 264 0006
Tel: +1 905 856 5288
Fax: +1 905 856 1995

E-mail

ruggedcom.info.i-ia@siemens.com

Web

www.siemens.com/ruggedcom

Table of Contents

Preface	v
Alerts	v
Related Documents	v
Accessing Documentation	v
Training	vi
Customer Support	vi
 Chapter 1	
Introduction	1
1.1 Feature Highlights	1
1.2 Description	2
1.3 Precision Time Protocol (PTP) Support	4
1.3.1 Supported Time Synchronization Sources	4
1.3.2 TTL Outputs	5
1.3.3 IEEE 1588 Support	6
 Chapter 2	
Installing Device	7
2.1 Mounting the Device	7
2.1.1 Mounting the Device to a Rack	8
2.1.2 Mounting the Device on a DIN Rail	9
2.1.3 Mounting the Device to a Panel	9
2.2 Connecting Power	10
2.2.1 Connecting AC Power	11
2.2.2 Connecting DC Power	12
2.2.3 Wiring Examples	13
2.3 Connecting the Failsafe Alarm Relay	16
2.4 Grounding the Device	17
2.5 Connecting to the Device	17
2.6 Cabling Recommendations	18
 Chapter 3	
Communication Ports	19
3.1 Copper Ethernet Ports	19
3.2 Fiber Optic Ethernet Ports	20

3.3	Serial Ports	21
3.4	BNC Ports	24
3.5	Connecting Multiple RS485 Devices	25
Chapter 4		
	Technical Specifications	27
4.1	Power Supply Specifications	27
4.2	Failsafe Relay Specifications	27
4.3	Copper Ethernet Port Specifications	28
4.4	Fiber Optic Ethernet Port Specifications	28
4.4.1	10Base-FL Ethernet Optical Specifications	28
4.4.2	Fast Ethernet (100 Mbps) Optical Specifications	28
4.5	Serial Port Specifications	29
4.5.1	Copper Serial Port Specifications	29
4.5.2	Fiber Serial Port Specifications	30
4.6	PTP Specifications	30
4.7	Operating Environment	30
4.8	Mechanical Specifications	30
Chapter 5		
	Dimension Drawings	33
Chapter 6		
	Certification	37
6.1	Standards Compliance	37
6.2	Agency Approvals	37
6.3	EMI and Environmental Type Tests	38

Preface

This guide describes the RUGGEDCOM RS416. It describes the major features of the device, installation, commissioning and important technical specifications.

It is intended for use by network technical support personnel who are responsible for the installation, commissioning and maintenance of the device. It is also recommended for use by network and system planners, system programmers, and line technicians.

Alerts

The following types of alerts are used when necessary to highlight important information.



DANGER!

DANGER alerts describe imminently hazardous situations that, if not avoided, will result in death or serious injury.



WARNING!

WARNING alerts describe hazardous situations that, if not avoided, may result in serious injury and/or equipment damage.



CAUTION!

CAUTION alerts describe hazardous situations that, if not avoided, may result in equipment damage.



IMPORTANT!

IMPORTANT alerts provide important information that should be known before performing a procedure or step, or using a feature.



NOTE

NOTE alerts provide additional information, such as facts, tips and details.

Related Documents

Other documents that may be of interest include:

- *ROS User Guide for the RS416*

Accessing Documentation

The latest Hardware Installation Guides and Software User Guides for most RUGGEDCOM products are available online at www.siemens.com/ruggedcom.

For any questions about the documentation or for assistance finding a specific document, contact a Siemens sales representative.

Training

Siemens offers a wide range of educational services ranging from in-house training of standard courses on networking, Ethernet switches and routers, to on-site customized courses tailored to the customer's needs, experience and application.

Siemens' Educational Services team thrives on providing our customers with the essential practical skills to make sure users have the right knowledge and expertise to understand the various technologies associated with critical communications network infrastructure technologies.

Siemens' unique mix of IT/Telecommunications expertise combined with domain knowledge in the utility, transportation and industrial markets, allows Siemens to provide training specific to the customer's application.

For more information about training services and course availability, visit www.siemens.com/ruggedcom or contact a Siemens sales representative.

Customer Support

Customer support is available 24 hours, 7 days a week for all Siemens customers. For technical support or general information, contact Siemens Customer Support through any of the following methods:

- **Online**

Visit <http://www.siemens.com/automation/support-request> to submit a Support Request (SR) or check on the status of an existing SR.

- **Telephone**

Call a local hotline center to submit a Support Request (SR). To locate a local hotline center, visit <http://www.automation.siemens.com/mcms/aspa-db/en/automation-technology/Pages/default.aspx>.

- **Mobile App**

Install the Industry Online Support app by Siemens AG on any Android, Apple iOS or Windows mobile device and be able to:

- Access Siemens' extensive library of support documentation, including FAQs, manuals, and much more
- Submit SRs or check on the status of an existing SR
- Find and contact a local contact person
- Ask questions or share knowledge with fellow Siemens customers and the support community
- And much more...

1 Introduction

The RUGGEDCOM RS416 is an industrially hardened serial device server with an integrated, fully managed, Ethernet switch, designed to operate reliably in electrically harsh and climatically demanding environments. Featuring a modular design that can support IEEE 1588 and IRIG-B time synchronization, up to 16 serial ports and up to four Ethernet ports, the RS416 is able to interconnect and synchronize multiple types of intelligent electronic devices (IEDs).

The time source is provided via IEEE 1588 v2 and converted to IRIG-B for distribution to the IEDs via the serial ports or dedicated IRIG-B cabling. Each serial port supports standard data communications plus an IRIG-B time-synchronization output. Using the RS416 results in fewer connectivity devices reducing overall system costs and extends the useful life of existing legacy IEDs minimizing capital expenditure for new equipment.

The RS416 provides a high level of immunity to electromagnetic interference and heavy electrical surges typical of environments found in electric utility substations, factory floors or in curb side traffic control cabinets. The RS416 meets or exceeds a wide range of industry standards including IEC 61850-3, IEEE 1613, IEC 61000-6-2 and IEC 61800-3. The RS416 also features a wide operating temperature range of -40 to 85 °C (-40 to 185 °F) allowing it to be installed in virtually any location.

The embedded Rugged Operating System (ROS®) within the RS416 provides advanced layer 2 and layer 3 networking functions, advanced cyber security features, and a full array of intelligent functionality for high network availability and manageability. Coupled with the ruggedized hardware design, the RS416 is ideal for creating mission-critical, real-time, control applications in any harsh environment.

The following sections provide more information about the RS416:

- [Section 1.1, “Feature Highlights”](#)
- [Section 1.2, “Description”](#)
- [Section 1.3, “Precision Time Protocol \(PTP\) Support”](#)

Section 1.1

Feature Highlights

Serial Device Server

- Modular design allows for 4, 8, 12, or 16 serial ports
- Fully compliant EIA RS422/TIA RS485, RS422, RS232 serial ports (software selectable) with IRIG-B outputs
- Serial fiber interface (ST)
- Transmit serial data over an IP network
- Support for Modbus TCP, DNP 3, TIN serial protocols
- Baud rates up to 230 kbps
- Raw socket mode allows conversion of any serial protocol
- Point-to-point and multi-point modes
- Converts Modbus RTU to Modbus
- Supports multiple Modbus masters

- Converts DNP3.0 to DNP over UDP/TCP

Ethernet Ports

- Integrated Ethernet switch
- Copper or fiber options
- Supports IEEE 1588 v2
- Non-blocking, store and forward switching

IRIG-B Option

- Conversion from IEEE 1588 v2
- One IRIG-B PWM/PPS Output
- One IRIG-B PWM Input
- Supports TTL levels
- BNC Connectors

IEEE 1588

- Internal clock is synchronized with IEEE 1588 version 2
- 100 μ s time accuracy

Rated for Reliability in Harsh Environments

- Immunity to EMI and heavy electrical surges
- Fully independent 2 kV (RMS) isolated serial ports
- -40 to 85 °C (-40 to 185 °F) operating temperature (no fans)
- 18 AWG galvanized steel enclosure

Universal Power Supply Options

- Fully integrated, dual-redundant (optional) power supplies
- Universal high-voltage range: 88-300 VDC or 85-264 VAC
- Popular low voltage ranges: 24 VDC (10-36 VDC), 48 VDC (36-59VDC)
- Terminal blocks for reliable maintenance free connections
- CSA/UL 60950-1 safety approved to 85 °C (185 °F)

Section 1.2

Description

The RS416 features various ports, controls and indicator LEDs on the display panel for connecting, configuring and troubleshooting the device. The display panel can be located on the rear, front or top of the device, depending on the mounting configuration.

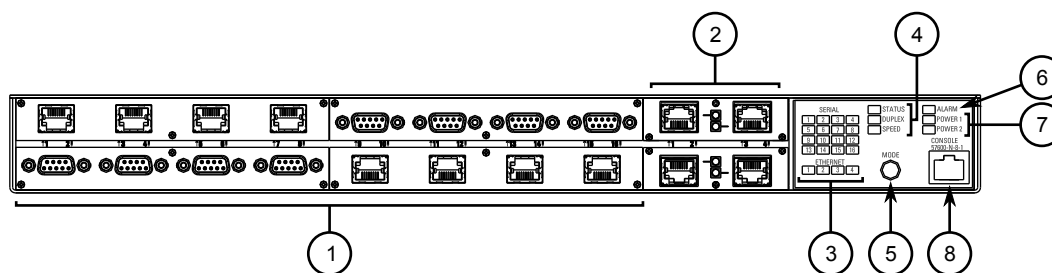

Figure 1: RUGGEDCOM RS416

1. Serial Ports 2. Fiber Optic Ethernet and/or BNC (Optional) Ports 3. Port Status Indicator LEDs 4. Display Mode Indicator LEDs
5. Mode Button 6. Alarm Indicator LED 7. Power Module Indicator LEDs 8. RS-232 Serial Console Port (RJ45)

- **Communication Ports** – Ports for communicating with other devices or accessing the RUGGEDCOM ROS operating system are described in [Chapter 3, Communication Ports](#).
- **Port Status Indicator LEDs** – Port status indicator LEDs indicate the operational status of each port, dependent on the currently selected mode.

Mode	Color/State	Description	
		Ethernet Ports	Serial Ports
Status	Solid	Link detected	—
	Blinking	Link activity	Traffic detected
	Off	No link detected	No traffic
Duplex	Solid	Full duplex mode	
	Blinking	Half duplex mode	
	Off	No link detected	
Speed	Green (Solid)	1000 Mb/s	+ 57601 bps
	Green (Blinking)	100 Mb/s	19201 to 57600 bps
	Orange (Solid)	10 Mb/s	0 to 19200 bps
	Off	No link detected	

- **Display Mode Indicator LEDs** – The display mode indicator LEDs indicate the current display mode for the port status indicator LEDs (i.e. Status, Duplex or Speed).
- **Mode button** – The **Mode** button sets the display mode for the port status indicator LEDs (i.e. Status, Duplex or Speed). It can also be used to reset the device if held for 5 seconds.
- **Alarm Indicator LED** – The alarm indicator LED illuminates when an alarm condition exists.
- **Power Module Indicator LEDs** – The power module indicator LEDs indicate the status of the power modules.
 - **Green** – The power supply is supplying power
 - **Red** – Power supply failure
 - **Off** – No power supply is installed
- **RS-232 Console Port** – The serial console port is for interfacing directly with the device and accessing initial management functions. For information about connecting to the device via the serial console port, refer to [Section 2.5, “Connecting to the Device”](#).

Section 1.3

Precision Time Protocol (PTP) Support

The Precision Time Protocol (PTP) module adds the ability to provide time synchronization via Ethernet using the Precision Time Protocol (PTP) and Network Time Protocol (NTP), and to synchronize with an external IRIG-B source.

The PTP module features BNC ports for TTL IN and TTL OUT. It also includes an LED to indicate when synchronization has been achieved.



NOTE

The PTP module can only be installed in slot 5. For more information, refer to [Chapter 3, Communication Ports](#).

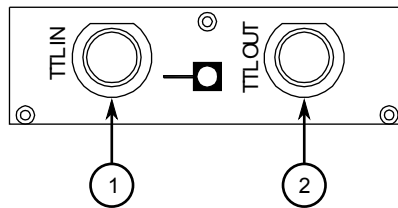

Figure 2: PTP Module

1. TTL OUT Port 2. TTL IN Port

For more information about the BNC ports, refer to [Section 3.4, “BNC Ports”](#).

The following sections describe the PTP support in more detail:

- [Section 1.3.1, “Supported Time Synchronization Sources”](#)
- [Section 1.3.2, “TTL Outputs”](#)
- [Section 1.3.3, “IEEE 1588 Support”](#)

Section 1.3.1

Supported Time Synchronization Sources

The following time synchronization sources are supported by the RS416, with or without the PTP card:

Synchronization Source	Without PTP Card	With PTP Card
NTP	✓	✓
IEEE 1588 v2	✓	✓
IRIG-B PWM	x	✓

NTP

NTP (Network Time Protocol) is the standard for synchronizing the clocks of computer systems throughout the Internet and is suitable for systems that require accuracies in the order of 1 ms.

IRIG-B PWM

IRIG-B time synchronization is an even older, established, inter-device time synchronization mechanism providing accuracy in sub-milliseconds.

IEEE 1588

IEEE 1588 is designed to provide networked, packet-based time synchronization between different networking nodes (PTP devices). The RS416 supports PTP v2, which is defined in the IEEE 1588-2008 standard. IEEE 1588 is designed to fill a niche not well served by either of the two older, dominant protocols, NTP and IRIG-B. IEEE 1588 is also designed for applications that cannot bear the cost of a GPS receiver at each node or for which GPS signals are inaccessible.

The RS416 only supports ordinary clock mode. An ordinary clock can be configured as either a Grandmaster Clock (GM) or a Slave Clock (SC) within the master-slave hierarchy.

Every Ethernet port on the RS416 supports IEEE 1588. For more information, refer to [Section 1.3.3, “IEEE 1588 Support”](#).

Section 1.3.2

TTL Outputs

The PTP card provides a TTL (Transistor-Transistor Logic) output.

The TTL OUT port supports the IRIG-B PWM and PPS signal formats. Enabling/disabling the output port and selecting the signal format is controlled through the RUGGEDCOM ROS operating system.

The number of devices that can be connected to the TTL Out port is dependent on the cabling type and length, as well as the input impedances of the devices. The following simplified circuit schematic shows the interface between an IRIG-B source and connected devices.

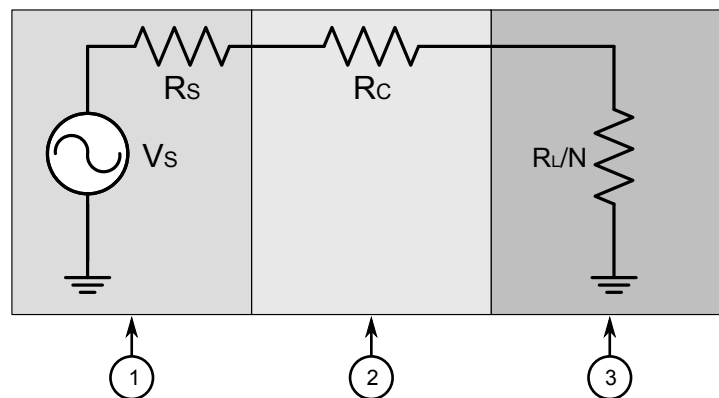

Figure 3: IRIG-B Simplified Circuit Schematic

1. Source 2. Cabling 3. Device

The maximum number of devices (N) that can be connected to the source is determined by checking if the source current (IS) required to drive the connected devices is less than the maximum drive current the source can provide, and verifying that the load voltage (VL) the connected devices see is greater than the minimum required voltage.

Section 1.3.3

IEEE 1588 Support

RUGGEDCOM RS416 supports various IEEE 1588 time synchronization capabilities and provides synchronization in 2-step mode. This mode supports the following clock types:

- End-to-End Slave Clock
- End-to-End Master Clock
- Peer-to-Peer Slave Clock
- Peer-to-Peer Master Clock

2 Installing Device

The following sections describe how to install the device, including mounting the device, installing/removing modules, connecting power, and connecting the device to the network.



DANGER!

Electrocution hazard – risk of serious personal injury and/or damage to equipment. Before performing any maintenance tasks, make sure all power to the device has been disconnected and wait approximately two minutes for any remaining energy to dissipate.



WARNING!

Radiation hazard – risk of serious personal injury. This product contains a laser system and is classified as a CLASS 1 LASER PRODUCT. Use of controls or adjustments or performance of procedures other than those specified herein may result in hazardous radiation exposure.



IMPORTANT!

This product contains no user-serviceable parts. Attempted service by unauthorized personnel shall render all warranties null and void.

Changes or modifications not expressly approved by Siemens Canada Ltd. could invalidate specifications, test results, and agency approvals, and void the user's authority to operate the equipment.



IMPORTANT!

This product should be installed in a restricted access location where access can only be gained by authorized personnel who have been informed of the restrictions and any precautions that must be taken. Access must only be possible through the use of a tool, lock and key, or other means of security, and controlled by the authority responsible for the location.

- [Section 2.1, “Mounting the Device”](#)
- [Section 2.2, “Connecting Power”](#)
- [Section 2.3, “Connecting the Failsafe Alarm Relay”](#)
- [Section 2.4, “Grounding the Device”](#)
- [Section 2.5, “Connecting to the Device”](#)
- [Section 2.6, “Cabling Recommendations”](#)

Section 2.1

Mounting the Device

The RS416 is designed for maximum mounting and display flexibility. It can be equipped with connectors that allow it to be installed in a 48 cm (19 in) rack, 35 mm (1.4 in) DIN rail, or directly on a panel.



NOTE

For detailed dimensions of the device with either rack, DIN rail or panel hardware installed, refer to Chapter 5, Dimension Drawings.

The following sections describe the various methods of mounting the device:

- Section 2.1.1, “Mounting the Device to a Rack”
- Section 2.1.2, “Mounting the Device on a DIN Rail”
- Section 2.1.3, “Mounting the Device to a Panel”

Section 2.1.1

Mounting the Device to a Rack

For rack mount installations, the RS416 can be equipped with rack mount adapters pre-installed at the front or rear of the chassis. Additional adapters are provided to further secure the device in high-vibration or seismically active locations.

To secure the device to a standard 48 cm (19 in) rack, do the following:



NOTE

The device can be ordered with the communication ports located at the front or rear of the device. Placing the ports at the rear allows all data and power cabling to be installed and connected at the rear of the rack.

1. Make sure the rack mount adapters are installed on the correct side of the chassis.



NOTE

The chassis features multiple mounting holes, allowing the rack mount adapters to be installed up to 25 mm (1 in) from the face of the device.

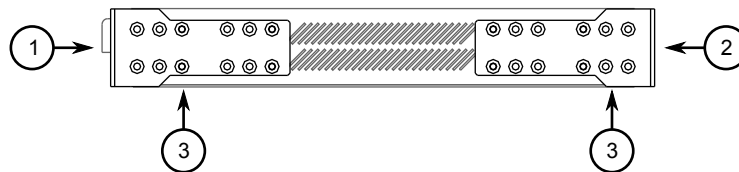

Figure 4: Rack Mount Adaptors

1. Rear 2. Front 3. Rack Mount Adaptor

2. If required, install adapters on the opposite side of the device to protect from vibrations.
3. Insert the device into the rack.



NOTE

Since heat within the device is channelled to the enclosure, it is recommended that 1 rack-unit of space, or 44 mm (1.75 in), be kept empty above the device. This allows a small amount of convectional airflow.

Forced airflow is not required. However, any increase in airflow will result in a reduction of ambient temperature and improve the long-term reliability of all equipment mounted in the rack space.

- Secure the adapters to the rack using the supplied hardware.

Section 2.1.2

Mounting the Device on a DIN Rail

For DIN rail installations, the RS416 can be equipped with panel/DIN rail adapters pre-installed on each side of the chassis. The adapters allow the device to be slid onto a standard 35 mm (1.4 in) DIN rail.



IMPORTANT!

DIN rail mounting is not recommended for constant vibration environments.

To mount the device to a DIN rail, do the following:

- Align the adapters with the DIN rails and slide the device into place.

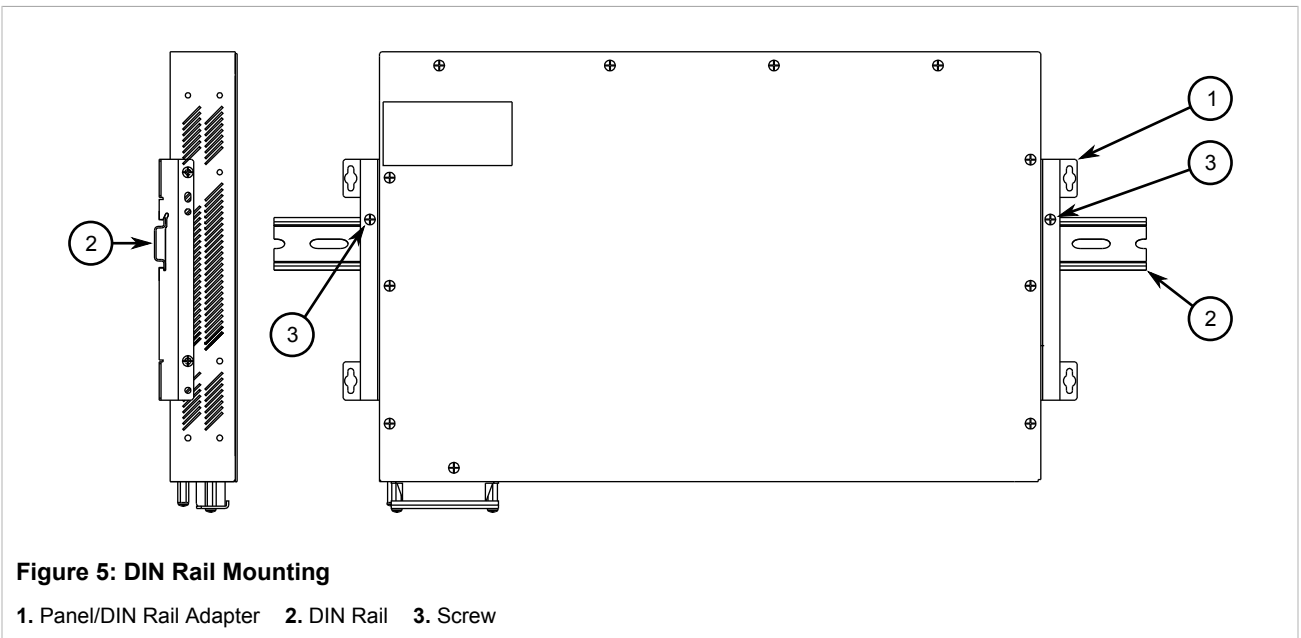

- Install one of the supplied screws on either side of the device to secure the adapters to the DIN rails.

Section 2.1.3

Mounting the Device to a Panel

For panel installations, the RS416 can be equipped with panel/DIN rail adapters pre-installed on each side of the chassis. The adapters allow the device to be attached to a panel using screws.

To mount the device to a panel, do the following:

- Place the device against the panel and align the adapters with the mounting holes.

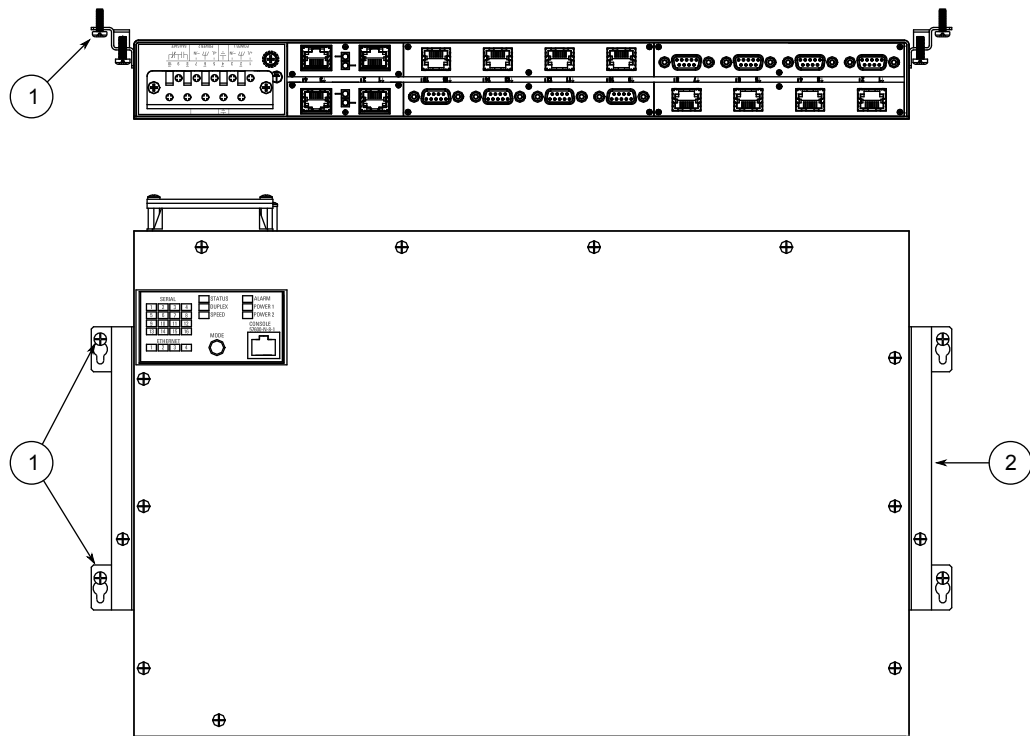

Figure 6: Panel Mounting

1. Screw 2. Panel/DIN Rail Adaptor

2. Install the supplied screws to secure the adapters to the panel.

Section 2.2

Connecting Power

The RS416 supports single or dual redundant high AC and/or low DC power supplies. The use of two power modules is recommended to provide redundancy and load balancing.

The RS416 can be equipped with either a screw-type or pluggable terminal block, which provides power to both power supplies. The screw-type terminal block is installed using Phillips screws and compression plates, allowing either bare wire connections or crimped terminal lugs. Use #6 size ring lugs for secure, reliable connections under severe shock or vibration.



NOTE

- For maximum redundancy in a dual power supply configuration, use two independent power sources.
- For 100-240 VAC rated equipment, an appropriately rated AC circuit breaker must be installed.
- For 88-300 VDC rated equipment, an appropriately rated DC circuit breaker must be installed.
- Use only #16 gage copper wiring when connecting terminal blocks.
- A circuit breaker is not required for 12, 24 or 48 VDC rated power supplies.

- *It is recommended to provide a separate circuit breaker for each power supply module.*
- *Equipment must be installed according to applicable local wiring codes and standards.*

The following sections describe how to connect power to the device:

- [Section 2.2.1, “Connecting AC Power”](#)
- [Section 2.2.2, “Connecting DC Power”](#)
- [Section 2.2.3, “Wiring Examples”](#)

Section 2.2.1

Connecting AC Power

To connect a high AC power supply to the device, do the following:



CAUTION!

Electrical hazard – risk of damage to equipment. Do not connect AC power cables to a DC power supply terminal block. Damage to the power supply may occur.



CAUTION!

Electrical hazard – risk of damage to equipment. Before testing the dielectric strength (HIPOT) in the field, remove the metal jumper. This metal jumper connects transient suppression circuitry to chassis ground and must be removed in order to avoid damage to transient suppression circuitry during testing.



NOTE

The terminal block is divided into separate terminals for each internal power supply. Make sure to connect the external power supply to the appropriate terminals.

1. Remove the terminal block cover.
2. If a screw-type terminal block is installed, remove the screws from the appropriate terminals. Use these screws along with #6 ring lugs to secure the wires to the terminal block.
3. Connect the positive wire from the power source to the positive/live (+/L) terminal on the terminal block. For more information, refer to [Section 2.2.3, “Wiring Examples”](#).

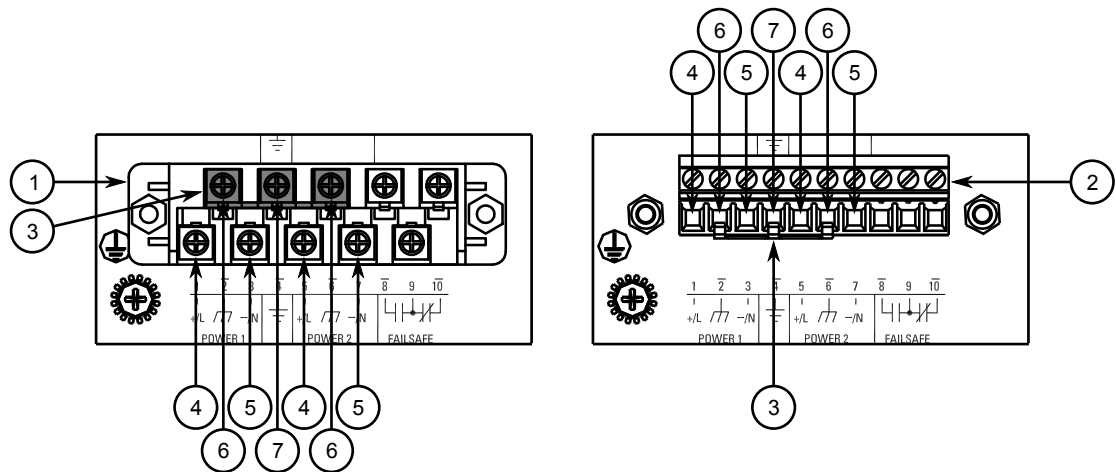

Figure 7: Terminal Block Wiring

1. Screw-Type Terminal Block 2. Pluggable Terminal Block 3. Jumper 4. Positive/Live (+/L) Terminal 5. Negative/Neutral (-/N) Terminal (-/N) 6. Surge Ground Terminal 7. Chassis Ground Terminal

4. Connect the negative wire from the power source to the negative/neutral (-/N) terminal on the terminal block. For more information, refer to [Section 2.2.3, “Wiring Examples”](#).
5. Install the supplied metal jumper between terminals 2, 4 and 6 to connect the surge ground terminals to the chassis ground terminal. The surge ground terminals are used as the ground conductor for all surge and transient suppression circuitry internal to the unit.
6. Connect the ground terminal on the power source to the chassis ground terminal on the device. For more information, refer to [Section 2.4, “Grounding the Device”](#)



DANGER!

Electrocution hazard – risk of death, serious personal injury and/or damage to the device. Make sure the supplied terminal block cover is always installed before the device is powered.

7. Install the terminal block cover.

Section 2.2.2

Connecting DC Power

To connect a single high or low DC power supply to the device, do the following:



CAUTION!

Electrical hazard – risk of damage to equipment. Before testing the dielectric strength (HIPOT) in the field, remove the metal jumper. This metal jumper connects transient suppression circuitry to chassis ground and must be removed in order to avoid damage to transient suppression circuitry during testing.



NOTE

The screw-type terminal block is installed using Philips screws and compression plates, allowing either bare wire connections or crimped terminal lugs. Use #6 size ring lugs for secure, reliable screws, which must be removed to make connections.

1. Remove the terminal block cover.
2. If a screw-type terminal block is installed, remove the screws from the appropriate terminals. Use these screws along with #6 ring lugs to secure the wires to the terminal block.
3. Connect the positive wire from the power source to the positive/live (+/L) terminal on the terminal block. For more information, refer to [Section 2.2.3, "Wiring Examples"](#).

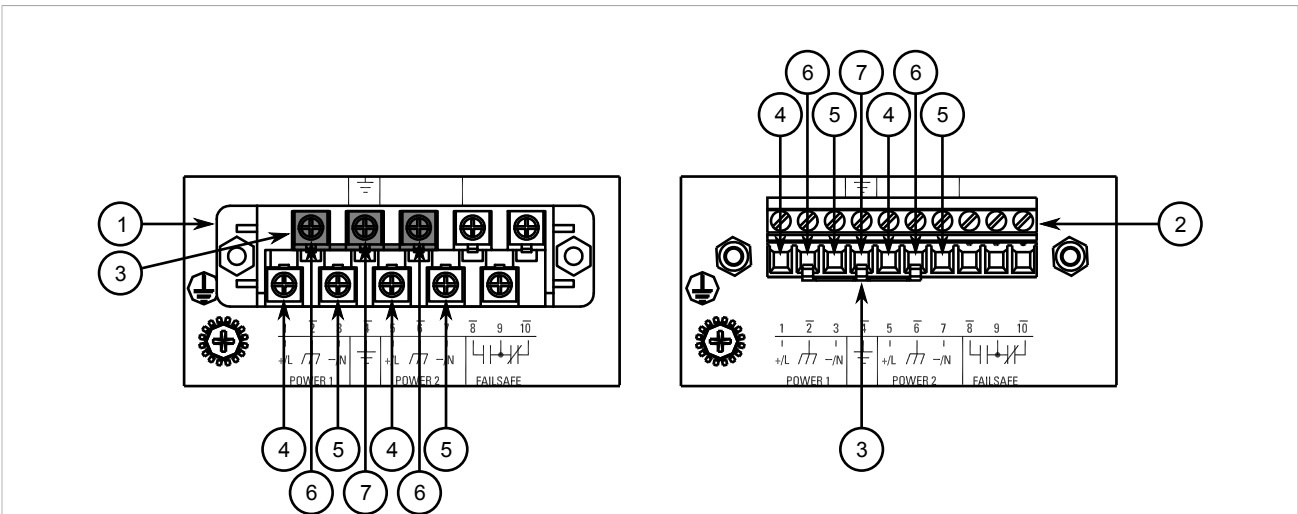

Figure 8: Terminal Block Wiring

1. Screw-Type Terminal Block 2. Pluggable Terminal Block 3. Jumper 4. Positive/Live (+/L) Terminal 5. Negative/Neutral (-/N) Terminal 6. Surge Ground Terminal 7. Chassis Ground Terminal

4. Connect the negative wire from the power source to the negative/neutral (-/N) terminal on the terminal block. For more information, refer to [Section 2.2.3, "Wiring Examples"](#).
5. Install the supplied metal jumper between terminals 2, 4 and 6 to connect the surge ground terminals to the chassis ground terminal. The surge ground terminals are used as the ground conductor for all surge and transient suppression circuitry internal to the unit.
6. Connect the ground terminal on the power source to the chassis ground terminal on the device. For more information, refer to [Section 2.4, "Grounding the Device"](#)



DANGER!

Electrocution hazard – risk of death, serious personal injury and/or damage to the device. Make sure the supplied terminal block cover is always installed before the device is powered.

7. Install the terminal block cover.

Section 2.2.3

Wiring Examples

The following illustrate how to connect power to single and dual power supplies.

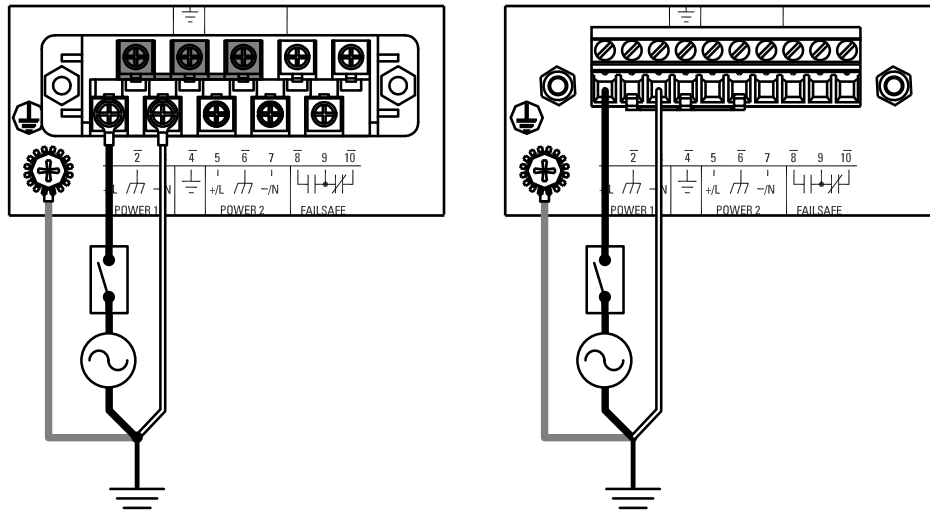

Figure 9: Single AC Power Supply

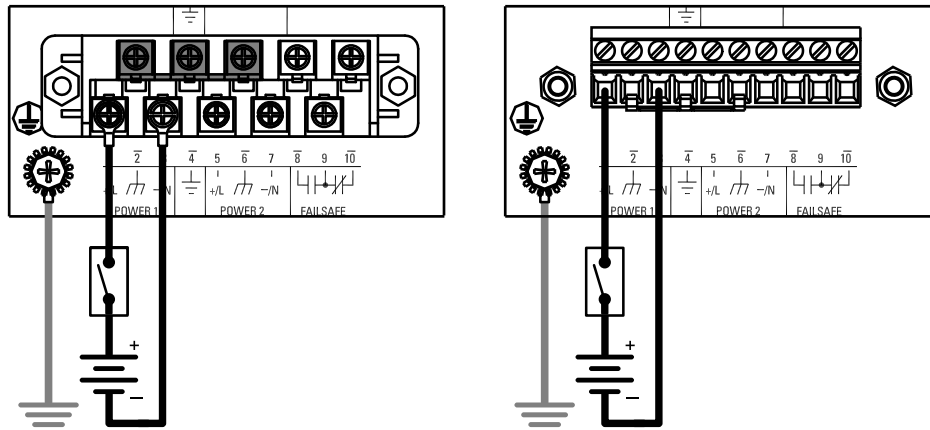

Figure 10: Single DC Power Supply

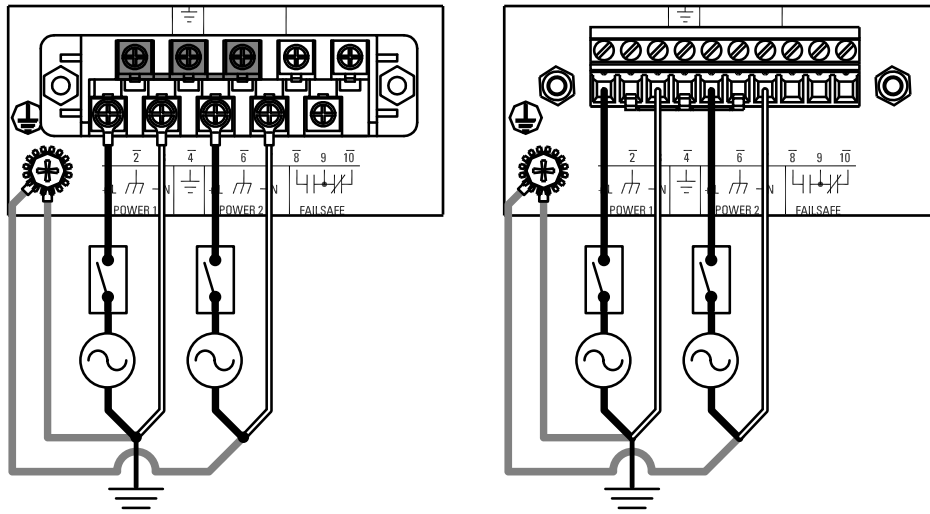

Figure 11: Dual AC Power Supply

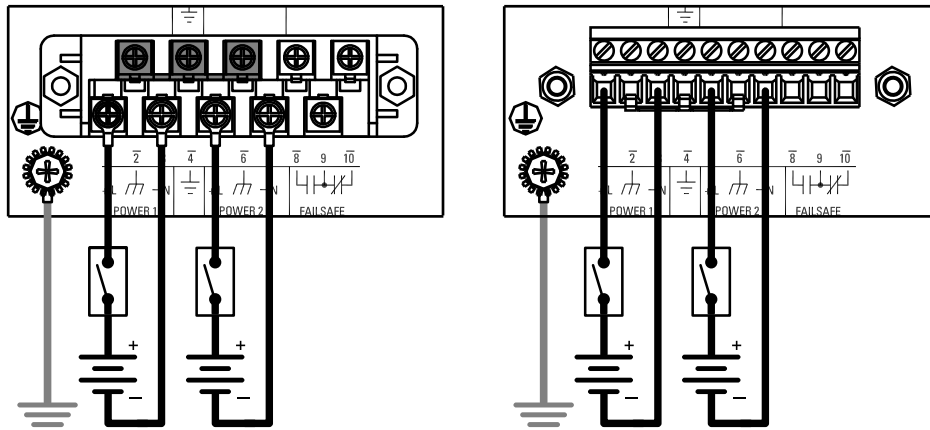
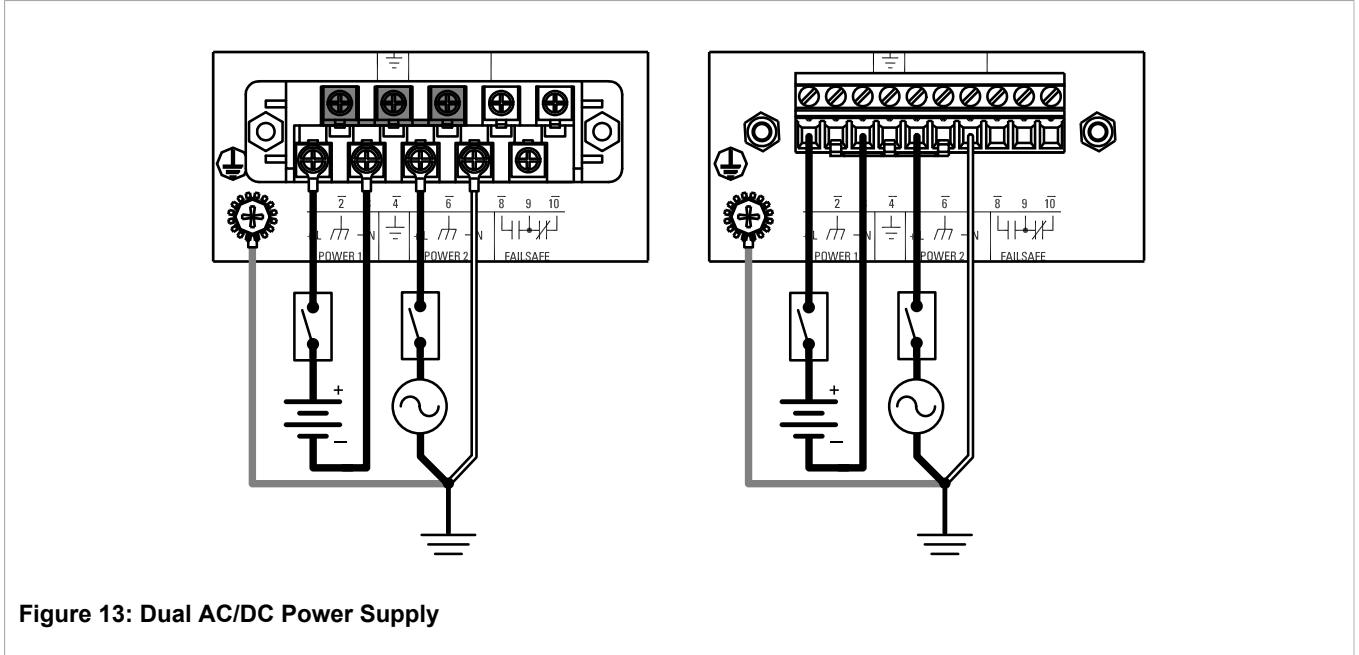

Figure 12: Dual DC Power Supply



Section 2.3

Connecting the Failsafe Alarm Relay

The failsafe relay can be configured to latch based on alarm conditions. The NO (Normally Open) contact is closed when the unit is powered and there are no active alarms. If the device is not powered or if an active alarm is configured, the relay opens the NO contact and closes the NC (Normally Closed) contact.



NOTE

Control of the failsafe relay output is configurable through ROS . One common application for this relay is to signal an alarm if a power failure occurs. For more information, refer to the ROS User Guide for the RS416.

The following shows the proper relay connections.

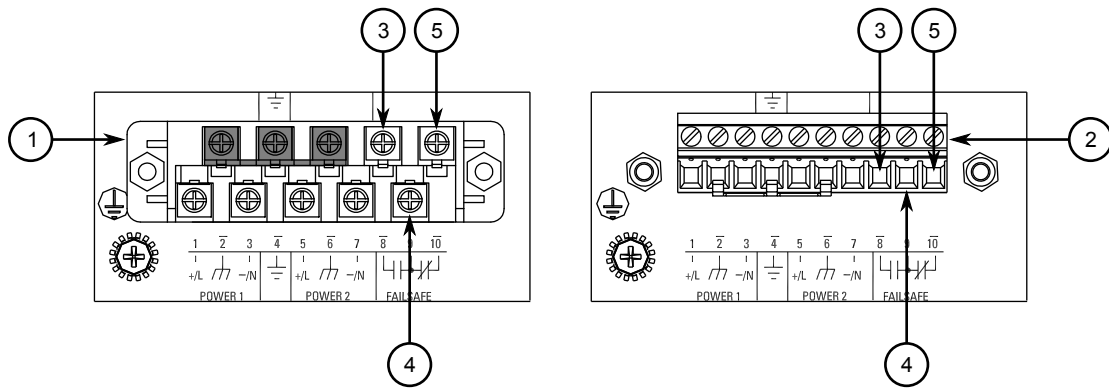

Figure 14: Failsafe Alarm Relay Wiring

1. Screw-Type Terminal Block 2. Pluggable Terminal Block 3. Normally Open Terminal 4. Common Terminal 5. Normally Closed Terminal

Section 2.4

Grounding the Device

The RS416 chassis ground terminal uses a #6-32 screw. It is recommended to terminate the ground connection with a #6 ring lug and torque it to 1.7 N·m (15 lbf·in).

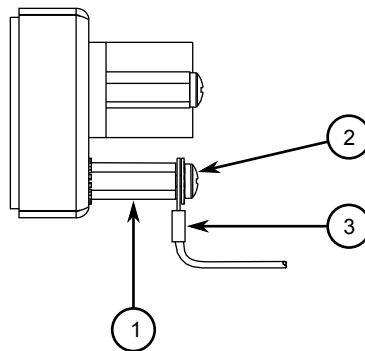

Figure 15: Chassis Ground Connection

1. Stainless Steel Stud 2. #6-32 Screw 3. #6 Ring Lug

Section 2.5

Connecting to the Device

The following describes the various methods for accessing the ROS console and Web interfaces on the device. For more detailed instructions, refer to the *ROS User Guide* for the RS416.

RS232 Console Port

Connect a PC or terminal directly to the RS232 console port to access the boot-time control and ROS interfaces. The console port provides access to ROS's console and Web interfaces.



IMPORTANT!

The console port is intended to be used only as a temporary connection during initial configuration or troubleshooting.

Connection to the console port is made using an RJ45-to-DB9 console cable. The following is the pin-out for the console port:

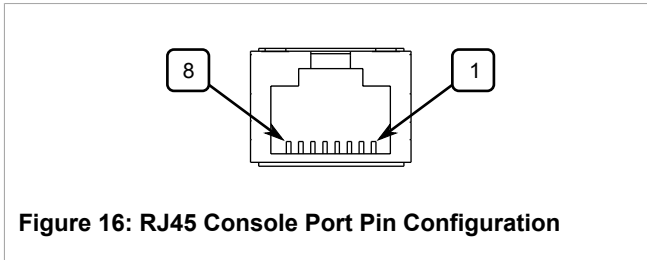

Pin		Name	Description
RJ45 Male	DB9 Female		
1	6	DSR ^a	Data Set Ready
2	1	Reserved (Do Not Connect)	
3	4	DTR ^a	Data Terminal Ready
4	5	GND	Signal Ground
5	2	RxD	Receive Data (to DTE)
6	3	TxD	Transmit Data (from DTE)
7	8	CTS ^b	Clear to Send
8	7	RTS ^b	Read to Send
1	9	RI ^c	Ring Indicator

^a The DSR, DCD and DTR pins are connected together internally.

^b The CTS and RTS pins are connected together internally.

^c RI is not connected.

Communication Ports

Connect any of the available Ethernet ports on the device to a management switch and access the ROS console and Web interfaces via the device's IP address. For more information about available ports, refer to [Chapter 3, Communication Ports](#).

Section 2.6

Cabling Recommendations

Siemens does not recommend the use of copper cabling of any length for critical, real-time substation automation applications. All copper Ethernet ports on RUGGEDCOM products include transient suppression circuitry to protect against damage from electrical transients and conform with IEC 61850-3 and IEEE 1613 Class 1 standards. This means that during a transient electrical event, communications errors or interruptions may occur, but recovery is automatic.

Siemens also does not recommend using copper Ethernet ports to interface with devices in the field across distances that could produce high levels of ground potential rise (i.e. greater than 2500 V), during line-to-ground fault conditions.

3 Communication Ports

The RUGGEDCOM RS416 can be equipped with various types of communication ports to enhance its abilities and performance.

Each communication port type has a specific place in the RUGGEDCOM RS416 chassis.

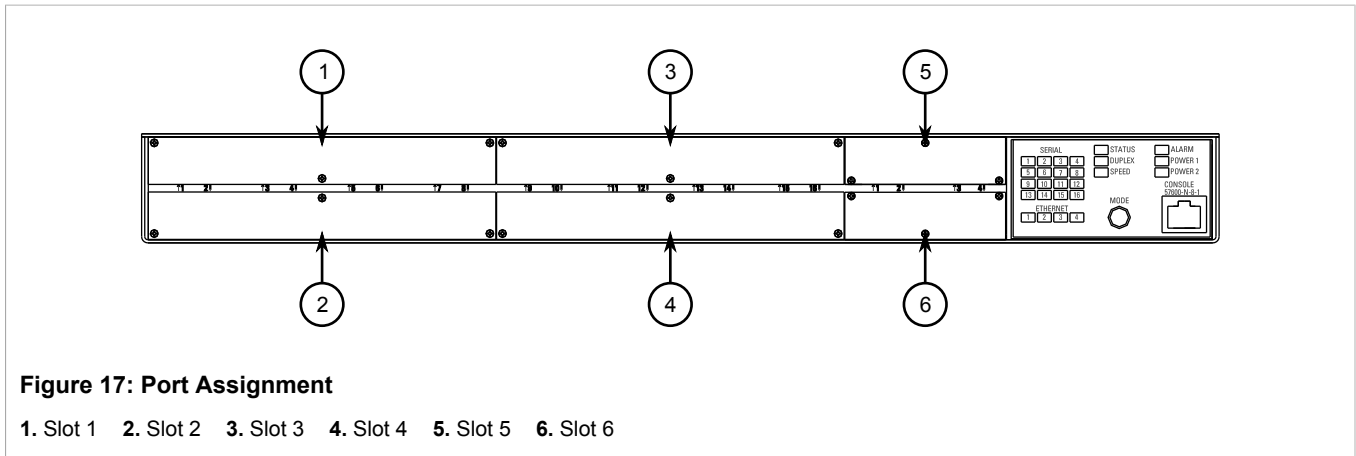

Slot	Type
1 to 4	Serial Ports
5	Fast Ethernet (10/100Base-TX, 10Base-FL or 10/100Base-FX) or BNC Ports
6	Fast Ethernet (10/100Base-TX, 10Base-FL or 10/100Base-FX)

The following sections describe the available ports:

- [Section 3.1, “Copper Ethernet Ports”](#)
- [Section 3.2, “Fiber Optic Ethernet Ports”](#)
- [Section 3.3, “Serial Ports”](#)
- [Section 3.4, “BNC Ports”](#)
- [Section 3.5, “Connecting Multiple RS485 Devices”](#)

Section 3.1

Copper Ethernet Ports

The RS416 supports several 10/100Base-TX Ethernet ports that allow connection to standard Category 5 (CAT-5) unshielded twisted-pair (UTP) cables with RJ45 male connectors. The RJ45 connectors are directly connected to the chassis ground on the device and can accept CAT-5 shielded twisted-pair (STP) cables.

WARNING!
Electric shock hazard – risk of serious personal injury and/or equipment interference. If shielded cables are used, make sure the shielded cables do not form a ground loop via the shield wire and the

RJ45 receptacles at either end. Ground loops can cause excessive noise and interference, but more importantly, create a potential shock hazard that can result in serious injury.

LEDs

Each port features LEDs that indicate the state of the port.

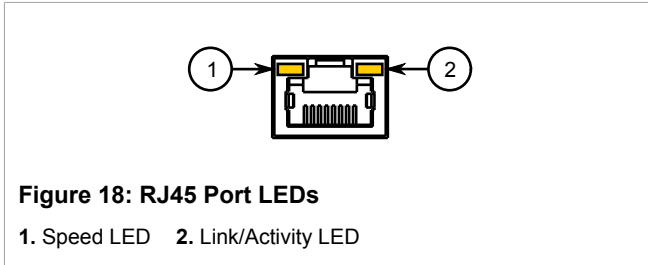

LED	State	Description
Speed	Yellow	The port is operating at 1000 Mbps
	Off	The port is operating at 10 or 100 Mbps
Link/Activity	Yellow (Solid)	Link established
	Yellow (Blinking)	Link activity
	Off	No link detected

Pin-Out

The following is the pin-out for the RJ45 male connectors:

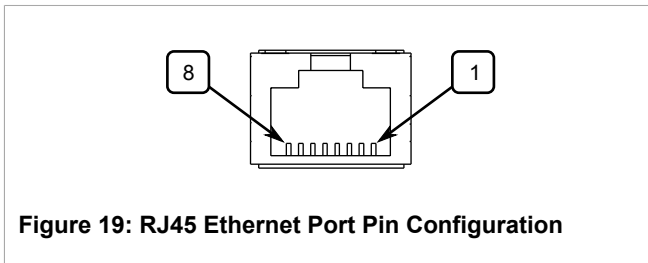

Pin	Name	Description
1	RX+	Receive Data+
2	RX-	Receive Data-
3	TX+	Transmit Data+
4	Reserved (Do Not Connect)	
5	Reserved (Do Not Connect)	
6	TX-	Transmit Data-
7	Reserved (Do Not Connect)	
8	Reserved (Do Not Connect)	

Specifications

For specifications on the available copper Ethernet ports, refer to [Section 4.3, “Copper Ethernet Port Specifications”](#).

Section 3.2

Fiber Optic Ethernet Ports

Fiber optic Ethernet ports are available with either MTRJ (Mechanical Transfer Registered Jack), LC (Lucent Connector), SC (Standard or Subscriber Connector) or ST (Straight Tip) connectors. Make sure the Transmit (Tx) and Receive (Rx) connections of each port are properly connected and matched to establish a proper link.

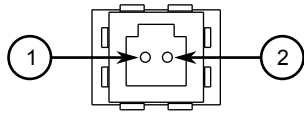

Figure 20: MTRJ Port

1. Tx Connector 2. Rx Connector

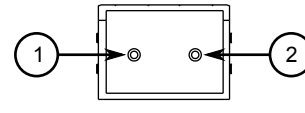

Figure 21: LC Port

1. Tx Connector 2. Rx Connector

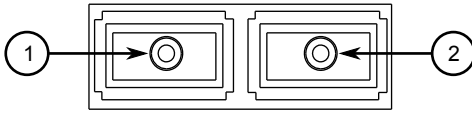

Figure 22: SC Port

1. Tx Connector 2. Rx Connector

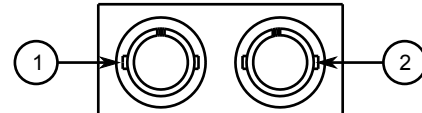

Figure 23: ST Port

1. Tx Connector 2. Rx Connector

For specifications on the available fiber optic Ethernet ports, refer to [Section 4.4, “Fiber Optic Ethernet Port Specifications”](#).

Section 3.3

Serial Ports

The RS416 supports serial cards with fiber serial ST (Straight Tip) connectors, RS232/RS485/RS422 DB9 serial ports or RS232/RS485/RS422 RJ45 serial ports.

Serial DB9 and RJ45 ports can be run in RS232, RS485 or RS422 mode. They can also be ordered with IRIG-B time code support.



NOTE

On power-up, all serial RJ45 ports default to RS485 mode. Each port can be individually set to RS232, RS485 or RS422 mode through ROS . For more information, refer to the ROS User Guide for the RS416.



NOTE

For information about how to connect devices configured to run in RS485 mode, refer to [Section 3.5, “Connecting Multiple RS485 Devices”](#).

All serial ports feature an LED that indicates the current state of the port.

State	Description
Green	Link activity detected
Off	No link detected

For specifications on serial ports, refer to [Section 4.5, “Serial Port Specifications”](#).

The following is the pin-out description for ST, DB9 and RJ45 serial ports:

Fiber Serial Port

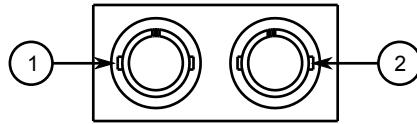

Figure 24: ST Port

1. Tx Connector 2. Rx Connector

Serial DB9 Port

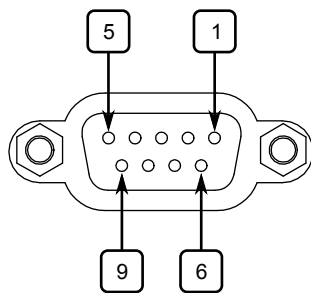

Figure 25: Serial DB9 Port Pin Configuration

Pin	Mode		
	RS232 DCE	RS485	RS422
1	DCD ^a		
2	TX ^b	TX/RX+	TX+
3	RX ^b		RX+
4	DTR ^a		
5	Common (Isolated) Ground		
6	DSR ^a		RX-
7	RTS	TX/RX-	TX-
8	CTS		
9	RI ^c		
Shield	Chassis Ground		

^a The DSR, DCD and DTR pins are connected together internally.

^b In RS232 DCE mode, ports transmit to DTE devices on pin 2 and receive from DTE on pin 3.

^c RI is not connected.



NOTE

Pins 1, 4 and 6 and pins 7 and 8 are connected internally. In RS232 mode, these pins enter a high impedance state. A DTE that asserts RTS will see CTS asserted. However, the device will not perform hardware flow control.

Serial DB9 Port with IRIG-B Support

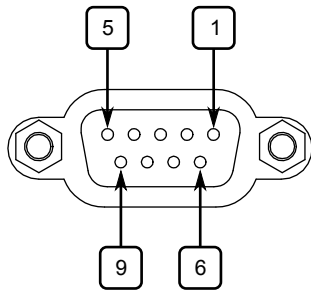

Figure 26: Serial DB9 Port Pin Configuration

Pin	Mode		
	RS232 DTE	RS485	RS422
1			RX-
2	RX ^d	TX/RX+	TX+
3	TX ^d		RX+
4	IRIG-B+		
5	Common (Isolated) Ground		
6	Common (Isolated) Ground		
7	RTS	TX/RX-	TX-
8	CTS		
9	Common (Isolated) Ground		
Shield	Chassis Ground		

^d In RS232 DTE mode, ports transmit to DTE devices on pin 2 and receive from DTE on pin 3.



NOTE

Pins 7 and 8 are connected internally. In RS232 mode, these pins enter a high impedance state. A DTE that asserts RTS will see CTS asserted. However, the device will not perform hardware flow control.

Serial RJ45 Port

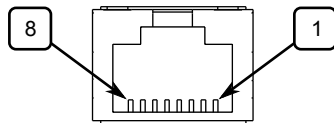

Figure 27: Serial RJ45 Port Pin Configuration

Pin	RS232 Mode	RS485 Mode	RS422 Mode
1	DSR ^e		RX-
2	DCD ^e		
3	DTR ^e		
4	Common (Isolated) Ground		
5	RXD ^f		RX+
6	TXD ^f	TX/RX+	TX+
7	CTS		
8	RTS	TX/RX-	TX-
Shield	Chassis Ground		

^e The DSR, DCD and DTR pins are connected together internally.

^f In RS232 mode, the RJ45 ports conform to EIA-561 DTE, which transmit on TXD and receive on RXD.



NOTE

Pins 1, 2 and 3 and pins 7 and 8 are connected internally. In RS232 mode, these pins enter a high impedance state. A DTE that asserts RTS will see CTS asserted. However, the device will not perform hardware flow control.

Serial RJ45 Port with IRIG-B Support

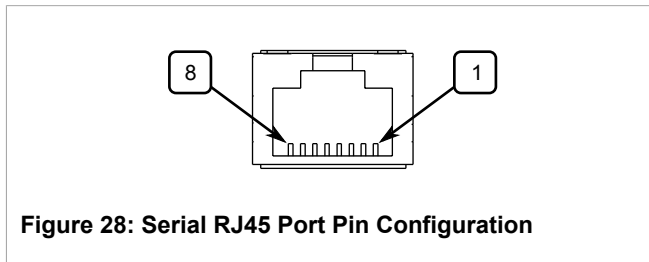

Pin	RS232 Mode	RS485 Mode	RS422 Mode
1			RX-
2	+IRIG-B		
3	Common (Isolated) Ground		
4	Common (Isolated) Ground		
5	RXD ⁹		RX+
6	TXD ⁹	TX/RX+	TX+
7	CTS		
8	RTS	TX/RX-	TX-
Shield	Chassis Ground		

⁹ In RS232 mode, the RJ45 ports conform to EIA-561 DTE, which transmit on TXD and receive on RXD.



NOTE

Pins 7 and 8 are connected internally. In RS232 mode, these pins enter a high impedance state. A DTE that asserts RTS will see CTS asserted. However, the device will not perform hardware flow control.

Section 3.4

BNC Ports

The following BNC ports are available on the PTP module:

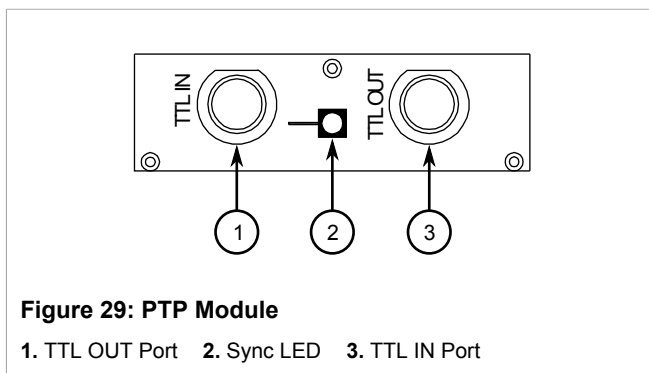

Port	Function
TTL OUT	IRIG-B PWM or 1 PPS signal output, software selectable
TTL IN	TTL-level IRIG-B PWM signal input

Inputs are controlled by RUGGEDCOM ROS and only one can be active at any time. For information about activating an input, refer to the *RUGGEDCOM ROS User Guide* for the RS416.

The color of the **Sync** LED on the front panel of the PTP module indicates the status of the incoming timing signal:

- **Green** – Signal locked
- **Amber/Yellow** – Holdover (GPS lock has been achieved, but the receiver no longer sees the minimum number of required satellites)
- **Red** – Error

- **Off** – No signal detected

Section 3.5

Connecting Multiple RS485 Devices

Each RS485 port can communicate with multiple RS485 devices by wiring devices together in sequence over a single twisted pair with transmit and receive signals on the same two wires (half duplex). For reliable, continuous communication, adhere to the following guidelines:

- To minimize the effects of ambient electrical noise, use shielded cabling.
- The correct polarity must be observed throughout a single sequence or ring.
- The number of devices wired should not exceed 32, and total distance should be less than 1219 m (4000 ft) at 100 kbps.
- The Common terminals should be connected to the common wire inside the shield.
- The shield should be connected to earth ground at a single point to avoid loop currents.
- The twisted pair should be terminated at each end of the chain.

The following shows the recommended RS485 wiring.

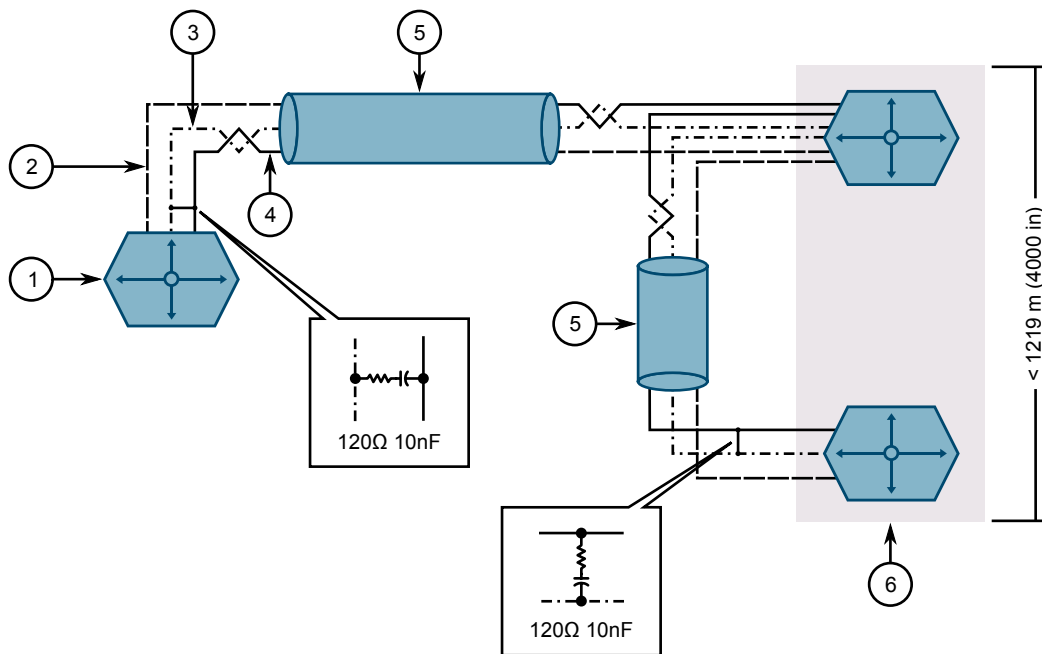

Figure 30: Recommended RS485 Wiring

1. RUGGEDCOM RS416 2. Common (Isolated Ground) 3. Negative 4. Positive 5. Shield to Earth (Connected At a Single Point)
6. RS485 Devices (32 Total)

4 Technical Specifications

The following sections provide important technical specifications related to the device and available modules:

- [Section 4.1, “Power Supply Specifications”](#)
- [Section 4.2, “Failsafe Relay Specifications”](#)
- [Section 4.3, “Copper Ethernet Port Specifications”](#)
- [Section 4.4, “Fiber Optic Ethernet Port Specifications”](#)
- [Section 4.5, “Serial Port Specifications”](#)
- [Section 4.7, “Operating Environment”](#)
- [Section 4.8, “Mechanical Specifications”](#)

Section 4.1

Power Supply Specifications

Power Supply Type	Input Range		Internal Fuse Rating ^{ab}	Isolation	Maximum Power Consumption ^c
	Minimum	Maximum			
12 VDC	10 VDC	36 VDC	6.3 A(F)	1.5 kVDC	25 W
24 VDC					
48 VDC					
HI (125/250 VDC) ^d	88 VDC	300 VDC	2 A(T)	4 kVAC, 5.5 kVDC	
HI (110/230 VAC) ^d					

^a (F) denotes fast-acting fuse

^b (T) denotes time-delay fuse.

^c Power consumption varies based on configuration. 10/100Base-TX ports consume roughly 1 W less than fiber optic ports.

^d The HI power supply is the same power supply for both AC and DC.

Section 4.2

Failsafe Relay Specifications

Maximum Switching Voltage	Rated Switching Current
30 VAC	0.3 A, 1.0 A
80 VDC	0.3

Section 4.3

Copper Ethernet Port Specifications

The following details the specifications for copper Ethernet ports that can be ordered with the RS416.

Speed ^e	Connector	Duplex ^e	Cable Type ^f	Wiring Standard ^g	Maximum Distance ^h	Isolation ⁱ
10/100Base-TX	RJ45	FDX/HDX	> CAT-5	TIA/EIA T568A/B	100 m (328 ft)	1.5 kV

^e Auto-negotiating.

^f Shielded or unshielded.

^g Auto-crossover and auto-polarity.

^h Typical distance. Dependent on the number of connectors and splices.

ⁱ RMS 1 minute.

Section 4.4

Fiber Optic Ethernet Port Specifications

The following sections detail fiber optic specifications for ports that can be equipped on the RS416..

- [Section 4.4.1, “10Base-FL Ethernet Optical Specifications”](#)
- [Section 4.4.2, “Fast Ethernet \(100 Mbps\) Optical Specifications”](#)

Section 4.4.1

10Base-FL Ethernet Optical Specifications

Mode	Connector Type	Cable Type (µm)	Tx λ (typ.) (nm)	Tx min (dBm)	Tx max (dBm)	Rx Sensitivity (dBm)	Rx Saturation (dBm)	Distance (typ.) (km)	Power Budget (dB)
MM	ST	62.5/125	850	-16	-9	-34	-11.2	2	18
		50/125		-19.8	-12.8				14.2

Section 4.4.2

Fast Ethernet (100 Mbps) Optical Specifications

Mode	Connector Type	Cable Type (µm)	Tx λ (typ.) (nm)	Tx min. (dBm)	Tx max. (dBm)	Rx Sensitivity (dBm)	Rx Saturation (dBm)	Distance (typ.) (km)	Power Budget (dB)
MM	ST	62.5/125	1300	-19	-14	-31	-14	2	12
		50/125		-22.5					8.5
MM	SC	62.5/125	1300	-19	-14	-31	-14	2	12

Mode	Connector Type	Cable Type (μm)	Tx λ (typ.) (nm)	Tx min. (dBm)	Tx max. (dBm)	Rx Sensitivity (dBm)	Rx Saturation (dBm)	Distance (typ.) (km)	Power Budget (dB)
		50/125		-22.5					8.5
MM	MTRJ	62.5/125	1300	-19	-14	-31	-14	2	12
		50/125		-22.5					8.5
SM	ST	9/125	1300	-15	-8	-32	-3	20	17
SM	SC	9/125	1300	-15	-8	-31	-7	20	16
SM	LC	9/125	1300	-15	-8	-34	-7	20	19
SM	LC	9/125	1300	-15	-8	-34	-7	20	19
SM	SC	9/125	1300	-5	0	-34	-3	50	29
SM	LC	9/125	1300	-5	0	-35	3	50	30
SM	SC	9/125	1300	0	5	-37	0	90	37
SM	LC	9/125	1300	0	5	-37	0	90	37
MM	MTRJ	62.5/125	1300	-19	-14	-31	-14	2	12
	LC	50/125		-22.5					8.5

Section 4.5

Serial Port Specifications

The following sections detail specifications for ports that can be equipped on the RS416.

- [Section 4.5.1, “Copper Serial Port Specifications”](#)
- [Section 4.5.2, “Fiber Serial Port Specifications”](#)

Section 4.5.1

Copper Serial Port Specifications

Baud Rate	Connector	Isolation
1200 to 230400 kbps	DB9	2.5 kV
1200 to 230400 kbps	RJ45	2.5 kV
1200 to 230400 kbps	DB9	2.5 kV
1200 to 230400 kbps	RJ45	2.5 kV

Section 4.5.2

Fiber Serial Port Specifications

Mode	Connector	Typical Distance (km)	Optical Wavelength (nm)	Cable Size
Multimode	ST	5	850	50/125
				62.5/125

Section 4.6

PTP Specifications

IRIG-B PWM Input Specifications

Parameter	Specification
Input Voltage	TTL-Compatible
Input Impedance	> 200 k Ω

IRIG-B PWM Output Specifications

Parameter	Specification
Output Current (I_s)	100 mA
Output Voltage (V_s)	TTL-Compatible
Output Impedance (R_s)	50 Ω

Section 4.7

Operating Environment

Parameter	Range	Comments
Ambient Operating Temperature	-40 to 85 °C (-40 to 185 °F)	Measured from a 30 cm (12 in) radius surrounding the center of the enclosure.
Ambient Relative Humidity	5% to 95%	Non-condensing
Ambient Storage Temperature	-40 to 85 °C (-40 to 185 °F)	

Section 4.8

Mechanical Specifications

Parameter	Value
Dimensions	Refer to Chapter 5, Dimension Drawings

Parameter	Value
Weight	4.5 kg (10 lbs)
Ingress Protection	IP40 (1 mm or 0.04 in objects)
Enclosure	18 AWG Galvanized Steel

5 Dimension Drawings



NOTE

All dimensions are in millimeters, unless otherwise stated.

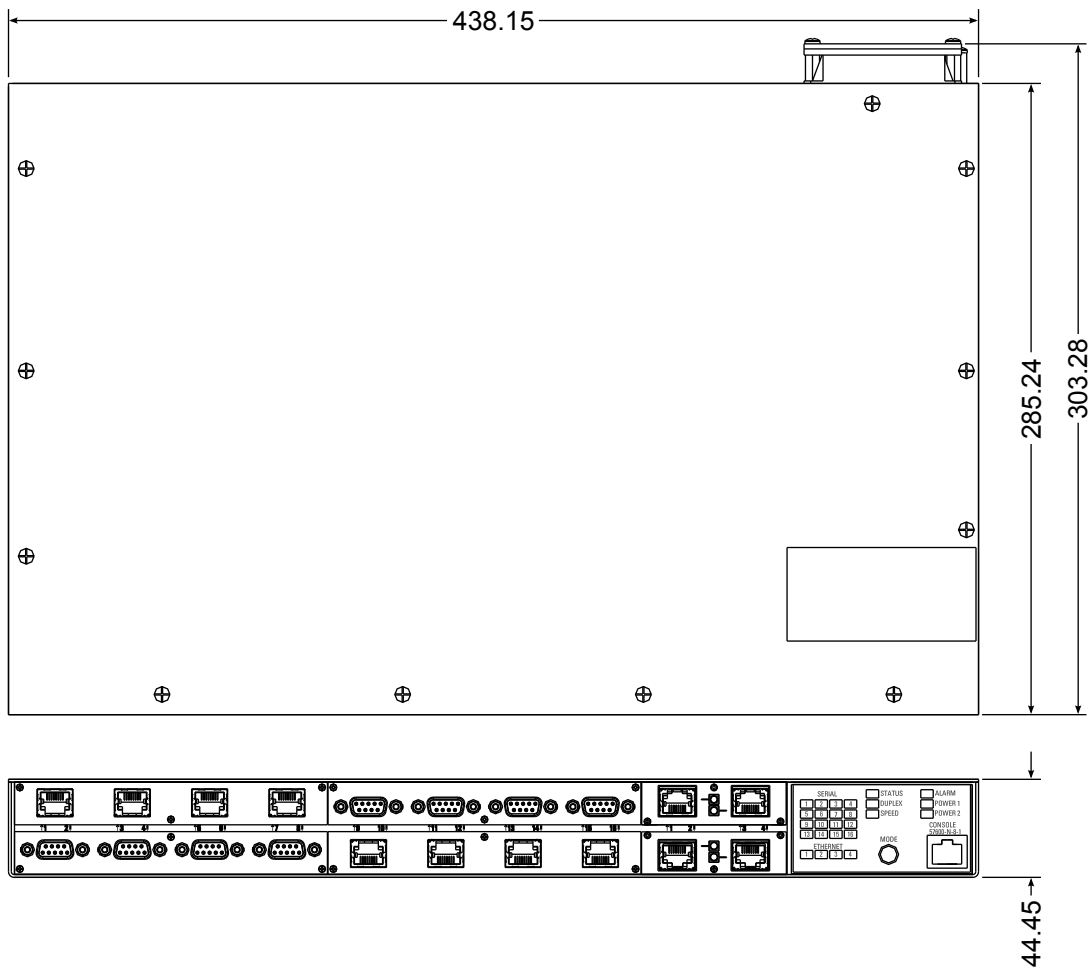

Figure 31: Overall Dimensions

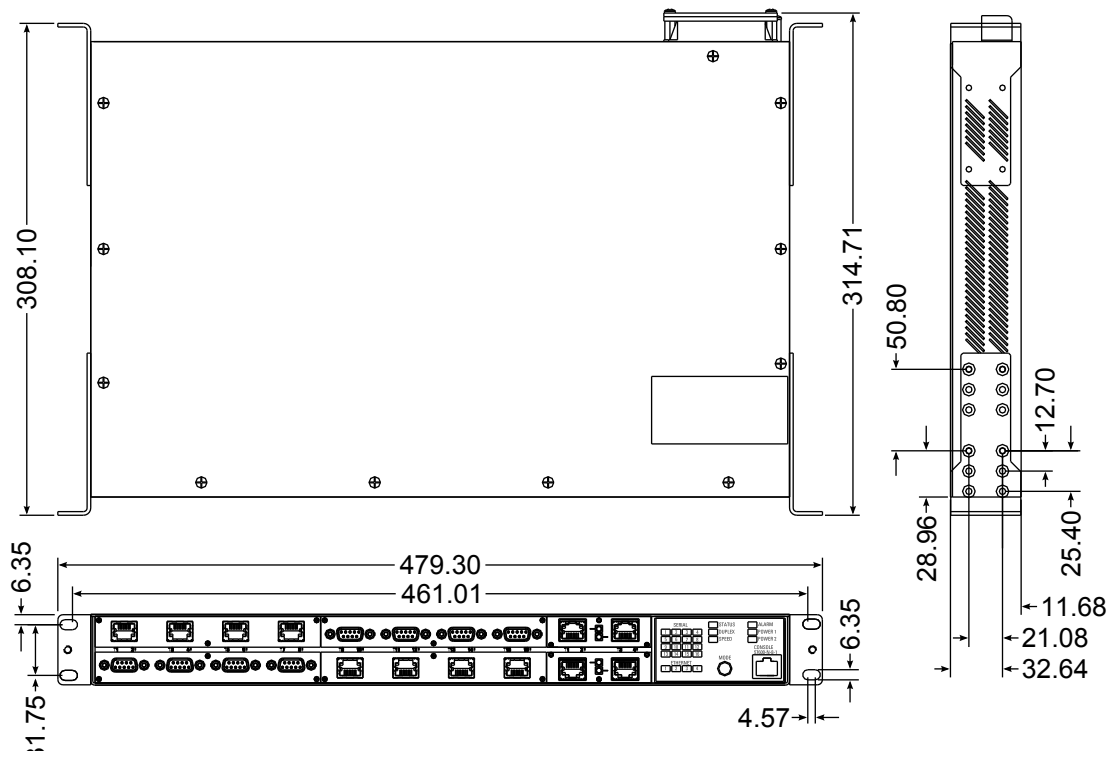

Figure 32: Rack Mount Dimensions

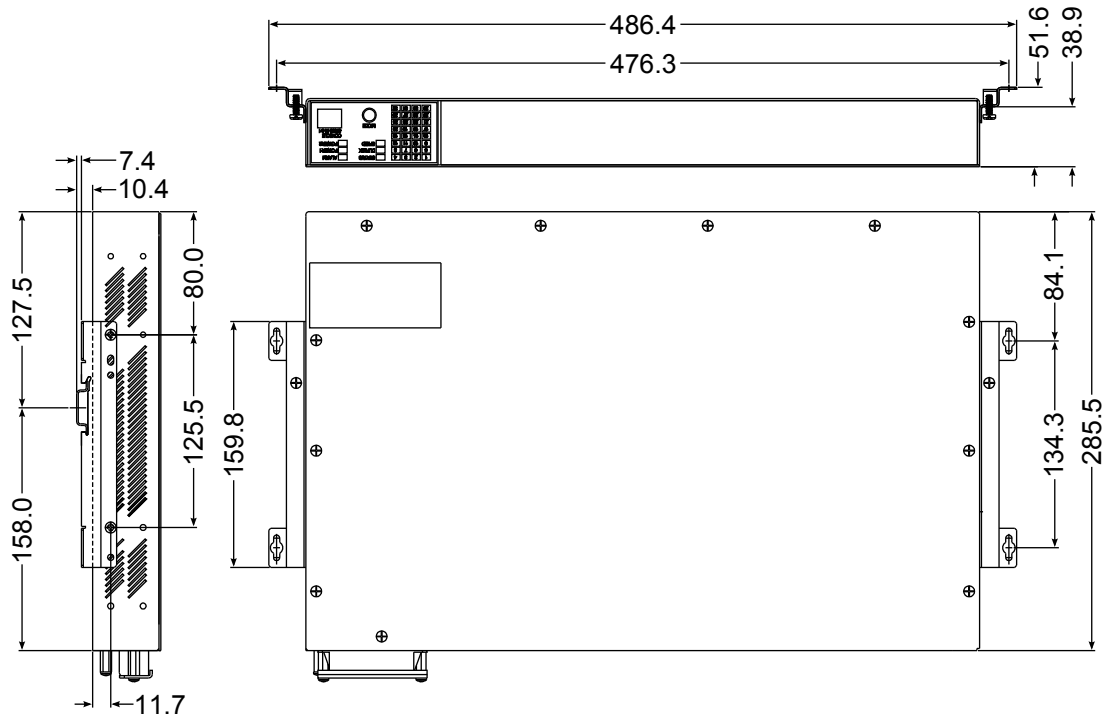

Figure 33: Panel and DIN Rail Mount Dimensions

6 Certification

The RUGGEDCOM RS416 device has been thoroughly tested to guarantee its conformance with recognized standards and has received approval from recognized regulatory agencies.

- [Section 6.1, “Standards Compliance”](#)
- [Section 6.2, “Agency Approvals”](#)
- [Section 6.3, “EMI and Environmental Type Tests”](#)

Section 6.1

Standards Compliance

The RUGGEDCOM RS416 complies with the following standards:

- **FCC Compliance**

This equipment has been tested and found to comply with the limits for a Class A digital device pursuant to Part 15 of the FCC Rules. These limits are designed to provide reasonable protection against harmful interference when the equipment is operated in a commercial environment.

This equipment generates, uses and can radiate radio frequency energy and, if not installed and used in accordance with the instruction manual, may cause harmful interference to radio communications. Operation of this equipment in a residential area is likely to cause harmful interference in which case the user will be required to correct the interference on his own expense.

- **Industry Canada Compliance**

CAN ICES-3 (A) / NMB-3 (A)

- **Other**

- IEEE 1613 (Electric Utility Substations)
- IEC 61850-3 (Electric Utility Substations)
- IEC 61000-6-2 (Generic Industrial)

Section 6.2

Agency Approvals

Agency	Standards	Comments
CSA	CSA C22.2 No. 60950-1, UL 60950-1	Approved
CE	EN 60950-1, EN 61000-6-2, EN 55022, EN 50581, EN 60825-1	Approved
FCC	FCC Part 15, Class A	Approved
FDA/CDRH	21 CFR Chapter I, Sub-chapter J	Compliant

Section 6.3

EMI and Environmental Type Tests

The RS416 has passed the following EMI and environmental tests.

IEC 61850-3 Type Tests

Test	Description	Test Levels	Severity Levels	
IEC 61000-4-2	ESD	Enclosure Contact	± 8 kV	4
		Enclosure Air	± 15 kV	4
IEC 61000-4-3	Radiated RFI	Enclosure ports	20 V/m	Note ^a
IEC 61000-4-4	Burst (Fast Transient)	Signal ports	± 4 kV @ 2.5 kHz	Note ^a
		DC Power ports	± 4 kV	4
		AC Power ports	± 4 kV	4
		Earth ground ports	± 4 kV	4
IEC 61000-4-5	Surge	Signal ports	± 4 kV line-to-earth, ± 2 kV line-to-line	4
		DC Power ports	± 2 kV line-to-earth, ± 1 kV line-to-line	3
		AC Power ports	± 4 kV line-to-earth, ± 2 kV line-to-line	4
IEC 61000-4-6	Induced (Conducted) RFI	Signal ports	10 V	3
		DC Power ports	10 V	3
		AC Power ports	10 V	3
		Earth ground ports	10 V	3
IEC 61000-4-8	Magnetic Field	Enclosure ports	100 A/m	Note ^a
			1000 A/m for 3 s	5
IEC 61000-4-29	Voltage Dips and Interrupts	DC Power ports	30% for 0.1 s, 60% for 0.1 s, 100% for 0.05 s	
IEC 61000-4-11		AC Power ports	30% for 1 period, 60% for 50 periods	
IEC 61000-4-12	Damped Oscillatory	Signal ports	2.5 kV common, 1 kV differential mode @ 1 MHz	3
		DC Power ports	2.5 kV common, 1 kV differential mode @ 1 MHz	3
		AC Power ports	2.5 kV common, 1 kV differential mode @ 1 MHz	3
IEC 61000-4-16	Mains Frequency Voltage	Signal ports	30 V Continuous, 300 V for 1 s	4
		DC Power ports	30 V Continuous, 300 V for 1 s	4
IEC 61000-4-17	Ripple on DC Power Supply	DC Power ports	± 15%	4

Test	Description		Test Levels	Severity Levels
IEC 60255-5	Dielectric Strength	Signal ports	2 kVAC (Fail-Safe Relay output)	
		DC Power ports	1.5 kVDC	
		AC Power ports	2 kVDC	
	HV Impulse	Signal ports	5 kV (Fail-Safe Relay Output)	
		DC Power ports	5 kV	
		AC Power ports	5 kV	

^a Siemens specified severity level.

IEEE 1613 EMI Immunity Type Tests



NOTE

The RS416 meets Class 2 requirements for an all-fiber configuration and Class 1 requirements for copper ports.

Description		Test Levels
ESD	Enclosure Contact	± 8 kV
	Enclosure Air	± 15 kV
Radiated RFI	Enclosure ports	35 V/m
Fast Transient	Signal ports	± 4 kV @ 2.5 kHz
	DC Power ports	± 4 kV
	AC Power ports	± 4 kV
	Earth ground ports	± 4 kV
Oscillatory	Signal ports	2.5 kV common mode @ 1MHz
	DC Power ports	2.5 kV common and differential mode @ 1MHz
	AC Power ports	2.5 kV common and differential mode @ 1MHz
HV Impulse	Signal ports	5 kV (Failsafe Relay)
	DC Power ports	5 kV
	AC Power ports	5 kV
Dielectric Strength	Signal ports	2 kVAC (Failsafe Relay)
	DC Power ports	1.5 kVDC
	AC Power ports	2 kVAC

Environmental Type Tests

Test	Description		Test Levels	Severity Levels
IEC 60068-2-1	Cold Temperature	Test Ad	-40 °C (-40 °F), 16 Hours	
IEC 60068-2-2	Dry Heat	Test Bd	85 °C (185 °F), 16 Hours	
IEC 60068-2-30	Humidity (Damp Heat, Cyclic)	Test Db	95% (non-condensing), 55 °C (131 °F), 6 cycles	

Test	Description	Test Levels	Severity Levels
IEC 60255-21-1	Vibration	2 g @ 10-150 Hz	Class 2
IEC 60255-21-2	Shock	30 g @ 11 ms	Class 2