



## ArmorBlock 2-port EtherNet/IP Modules with QuickConnect

Catalog Number 1732E-12X4M12QCDR, 1732E-12X4M12P5QCDR, 1732E-16CFG12QCR, 1732E-16CFG12P5QCR, 1732E-16CFG12QCWR

Topic	Page
Summary of Changes	1
Environment and Enclosure	3
Prevent Electrostatic Discharge	3
Before You Begin	3
Install the Module	4
Set the Network Address	4
Mount the Module	5
Connect the I/O, Network, and Auxiliary Cables to the Module	6
Configure the Module	8
Interpret Status Indicators	9
Specifications	11

### Summary of Changes

This publication contains the following new or updated information. This list includes substantive updates only and is not intended to reflect all changes.

Topic	Page
Added inclusive language acknowledgment	2
Updated Certifications	13
Added Additional Resources	13



**ATTENTION:** Read this document and the documents listed in the Additional Resources section about installation, configuration and operation of this equipment before you install, configure, operate or maintain this product. Users are required to familiarize themselves with installation and wiring instructions in addition to requirements of all applicable codes, laws, and standards.

Activities including installation, adjustments, putting into service, use, assembly, disassembly, and maintenance are required to be carried out by suitably trained personnel in accordance with applicable code of practice. If this equipment is used in a manner not specified by the manufacturer, the protection provided by the equipment may be impaired.

注意：在安装、配置、操作和维护本产品前，请阅读本文档以及“其他资源”部分列出的有关设备安装、配置和操作的相应文档。除了所有适用规范、法律和标准的相关要求之外，用户还必须熟悉安装和接线说明。

安装、调整、投运、使用、组装、拆卸和维护等各项操作必须由经过适当训练的专业人员按照适用的操作规范实施。

如果未按照制造商指定的方式使用该设备，则可能会损害设备提供的保护。

**ATENCIÓN:** Antes de instalar, configurar, poner en funcionamiento o realizar el mantenimiento de este producto, lea este documento y los documentos listados en la sección Recursos adicionales acerca de la instalación, configuración y operación de este equipo. Los usuarios deben familiarizarse con las instrucciones de instalación y cableado y con los requisitos de todos los códigos, leyes y estándares vigentes.

El personal debidamente capacitado debe realizar las actividades relacionadas a la instalación, ajustes, puesta en servicio, uso, ensamble, desensamble y mantenimiento de conformidad con el código de práctica aplicable. Si este equipo se usa de una manera no especificada por el fabricante, la protección provista por el equipo puede resultar afectada.

**ATENÇÃO:** Leia este e os demais documentos sobre instalação, configuração e operação do equipamento que estão na seção Recursos adicionais antes de instalar, configurar, operar ou manter este produto. Os usuários devem se familiarizar com as instruções de instalação e fiação além das especificações para todos os códigos, leis e normas aplicáveis.

É necessário que as atividades, incluindo instalação, ajustes, colocação em serviço, utilização, montagem, desmontagem e manutenção sejam realizadas por pessoal qualificado e especializado, de acordo com o código de prática aplicável.

Caso este equipamento seja utilizado de maneira não estabelecida pelo fabricante, a proteção fornecida pelo equipamento pode ficar prejudicada.

**ВНИМАНИЕ:** Перед тем как устанавливать, настраивать, эксплуатировать или обслуживать данное оборудование, прочитайте этот документ и документы, перечисленные в разделе «Дополнительные ресурсы». В этих документах изложены сведения об установке, настройке и эксплуатации данного оборудования. Пользователи обязаны ознакомиться с инструкциями по установке и прокладке соединений, а также с требованиями всех применимых норм, законов и стандартов.

Все действия, включая установку, наладку, ввод в эксплуатацию, использование, сборку, разборку и техническое обслуживание, должны выполняться обученным персоналом в соответствии с применимыми нормами и правилами.

Если оборудование используется не предусмотренным производителем образом, защита оборудования может быть нарушена.

注意：本製品を設置、構成、稼働または保守する前に、本書および本機器の設置、設定、操作についての参考資料の該当箇所に記載されている文書に目を通してください。ユーザは、すべての該当する条例、法律、規格の要件に加えて、設置および配線の手順に習熟している必要があります。

設置調整、運転の開始、使用、組立て、解体、保守を含む諸作業は、該当する実施規則に従って訓練を受けた適切な作業員が実行する必要があります。

本機器が製造メーカーにより指定されていない方法で使用されている場合、機器により提供されている保護が損なわれる恐れがあります。

**ACHTUNG:** Lesen Sie dieses Dokument und die im Abschnitt „Weitere Informationen“ aufgeführten Dokumente, die Informationen zu Installation, Konfiguration und Bedienung dieses Produkts enthalten, bevor Sie dieses Produkt installieren, konfigurieren, bedienen oder warten. Anwender müssen sich neben den Bestimmungen aller anwendbaren Vorschriften, Gesetze und Normen zusätzlich mit den Installations- und Verdrahtungsanweisungen vertraut machen.

Arbeiten im Rahmen der Installation, Anpassung, Inbetriebnahme, Verwendung, Montage, Demontage oder Instandhaltung dürfen nur durch ausreichend geschulte Mitarbeiter und in Übereinstimmung mit den anwendbaren Ausführungsvorschriften vorgenommen werden.

Wenn das Gerät in einer Weise verwendet wird, die vom Hersteller nicht vorgesehen ist, kann die Schutzfunktion beeinträchtigt sein.

**ATTENTION :** Lisez ce document et les documents listés dans la section Ressources complémentaires relatifs à l'installation, la configuration et le fonctionnement de cet équipement avant d'installer, configurer, utiliser ou entretenir ce produit. Les utilisateurs doivent se familiariser avec les instructions d'installation et de câblage en plus des exigences relatives aux codes, lois et normes en vigueur.

Les activités relatives à l'installation, le réglage, la mise en service, l'utilisation, l'assemblage, le démontage et l'entretien doivent être réalisées par des personnes formées selon le code de pratique en vigueur. Si cet équipement est utilisé d'une façon qui n'a pas été définie par le fabricant, la protection fournie par l'équipement peut être compromise.

주의：본 제품 설치, 설정, 작동 또는 유지 보수하기 전에 본 문서를 포함하여 설치, 설정 및 작동에 관한 참고 자료 섹션의 문서들을 반드시 읽고 숙지하십시오. 사용자는 모든 관련 규정, 법규 및 표준에서 요구하는 사항에 대해 반드시 설치 및 배선 지침을 숙지해야 합니다.

설치, 조정, 가동, 사용, 조립, 분해, 유지보수 등 모든 작업은 관련 규정에 따라 적절한 교육을 받은 사용자를 통해서만 수행해야 합니다.

본 장비를 제조사가 명시하지 않은 방법으로 사용하면 장비의 보호 기능이 손상될 수 있습니다.

**ATTENZIONE** Prima di installare, configurare ed utilizzare il prodotto, o effettuare interventi di manutenzione su di esso, leggere il presente documento ed i documenti elencati nella sezione "Altre risorse", riguardanti l'installazione, la configurazione ed il funzionamento dell'apparecchiatura. Gli utenti devono leggere e comprendere le istruzioni di installazione e cablaggio, oltre ai requisiti previsti dalle leggi, codici e standard applicabili.

Le attività come installazione, regolazioni, utilizzo, assemblaggio, disassemblaggio e manutenzione devono essere svolte da personale adeguatamente addestrato, nel rispetto delle procedure previste.

Qualora l'apparecchio venga utilizzato con modalità diverse da quanto previsto dal produttore, la sua funzione di protezione potrebbe venire compromessa.

**DIKKAT:** Bu ürünün kurulumu, yapılandırılması, işletilmesi veya bakımı öncesinde bu dokümanı ve bu ekipmanın kurulumu, yapılandırılması ve işletimi ile ilgili ilave Kaynaklar bölümünde yer listelenmiş dokümanları okuyun. Kullanıcılar yürürlükteki tüm yönetmelikler, yasalar ve standartların gereksinimlerine ek olarak kurulum ve kablolarla talimatlarını da öğrenmek zorundadır.

Kurulum, ayarlama, hizmete alma, kullanma, parçaları birleştirme, parçaları sökme ve bakım gibi aktiviteler sadece uygun eğitimli almış kişiler tarafından yürürlükteki uygulama yönetmeliklerine uygun şekilde yapılabilir.

Bu ekipman üretici tarafından belirlenmiş amacın dışında kullanılırsa, ekipman tarafından sağlanan koruma bozulabilir.

注意事項：在安装、設定、操作或維護本產品前，請先閱讀此文件以及列於「其他資源」章節中有關安裝、設定與操作此設備的文件。使用者必須熟悉安裝和配線指示，並符合所有法規、法律和標準要求。

包括安裝、調整、交付使用、使用、組裝、拆卸和維護等動作都必須交由已經過適當訓練的人員進行，以符合適用的實作法規。

如果將設備用於非製造商指定的用途時，可能會造成設備所提供的保護功能受損。

**POZOR:** Než začnete instalovat, konfigurovat či provozovat tento výrobek nebo provádět jeho údržbu, přečtěte si tento dokument a dokumenty uvedené v části Dodatečné zdroje ohledně instalace, konfigurace a provozu tohoto zařízení. Uživatelé se musejí vedle požadavků všech relevantních vyhlásek, zákonů a norem nutně seznámit také s pokyny pro instalaci a elektrické zapojení.

Činnosti zahrnující instalaci, nastavení, uvedení do provozu, užívání, montáž, demontáž a údržbu musí vykonávat vhodné proškolený personál v souladu s příslušnými prováděcími předpisy.

Pokud se toto zařízení používá způsobem neodpovídajícím specifikaci výrobce, může být narušena ochrana, kterou toto zařízení poskytuje.

**UWAGA:** Przed instalacją, konfiguracją, użytkowaniem lub konserwacją tego produktu należy przeczytać niniejszy dokument oraz wszystkie dokumenty wymienione w sekcji Dodatkowe źródła omawiające instalację, konfigurację i procedury użytkowania tego urządzenia. Użytkownicy mają obowiązek zapoznać się z instrukcjami dotyczącymi instalacji oraz oprzewodowania, jak również z obowiązującymi kodeksami, prawem i normami.

Działania obejmujące instalację, regulację, przekazanie do użytkowania, użytkowanie, montaż, demontaż oraz konserwację muszą być wykonywane przez odpowiednio przeszkolony personel zgodnie z obowiązującym kodeksem postępowania.

Jeśli urządzenie jest użytkowane w sposób inny niż określony przez producenta, zabezpieczenie zapewniane przez urządzenie może zostać ograniczone.

**OB!** Läs detta dokument samt dokumentet, som står listat i avsnittet Övriga resurser, om installation, konfigurering och drift av denna utrustning innan du installerar, konfigurerar eller börjar använda eller utföra underhållsarbete på produkten. Användare måste bekanta sig med instruktioner för installation och kabeldragning, förutom krav enligt gällande koder, lagar och standarder.

Åtgärder som installation, justering, service, användning, montering, demontering och underhållsarbete måste utföras av personal med lämplig utbildning enligt lämpligt bruk.

Om denna utrustning används på ett sätt som inte anges av tillverkaren kan det hända att utrustningens skyddsanordningar försätts ur funktion.

**LET OP:** Lees dit document en de documenten die genoemd worden in de paragraaf Aanvullende informatie over de installatie, configuratie en bediening van deze apparatuur voordat u dit product installeert, configureert, bedient of onderhoudt. Gebruikers moeten zich vertrouwd maken met de installatie en de bedringsinstructies, naast de vereisten van alle toepasselijke regels, wetten en normen.

Activiteiten zoals het installeren, afstellen, in gebruik stellen, gebruiken, monteren, demonteren en het uitvoeren van onderhoud mogen uitsluitend worden uitgevoerd door hiervoor opgeleid personeel en in overeenstemming met de geldende praktijkregels.

Indien de apparatuur wordt gebruikt op een wijze die niet is gespecificeerd door de fabrikant, dan bestaat het gevaar dat de beveiliging van de apparatuur niet goed werkt.

Rockwell Automation recognizes that some of the terms that are currently used in our industry and in this presentation are not in alignment with the movement toward inclusive language in technology. We are proactively collaborating with industry peers to find alternatives to such terms and making changes to our products and content. Please excuse the use of such terms in our content while we implement these changes.

## Environment and Enclosure



**ATTENTION:** This equipment is intended for use in overvoltage Category II applications (as defined in EN/IEC60664-1), at altitudes up to 2000 m (6562 ft) without derating.

This equipment is not intended for use in residential environments and may not provide adequate protection to radio communication services in such environments.

This equipment is supplied as enclosed equipment. It should not require additional system enclosure when used in locations consistent with the equipment Enclosure Type Ratings. Subsequent sections of this publication may contain more information regarding specific enclosure type ratings, beyond what this product provides, that are required to comply with certain product safety certifications.

In addition to this publication, see the following:

- Industrial Automation Wiring and Grounding Guidelines, publication [1770-4.1](#), for additional installation requirements.
- NEMA Standard 250 and EN/IEC 60529, as applicable, for explanations of the degrees of protection provided by enclosures.

## Prevent Electrostatic Discharge



**ATTENTION:** This equipment is sensitive to electrostatic discharge, which can cause internal damage and affect normal operation. Follow these guidelines when you handle this equipment:

- Touch a grounded object to discharge potential static.
- Wear an approved grounding wriststrap.
- Do not touch connectors or pins on component boards.
- Do not touch circuit components inside the equipment.
- Use a static-safe workstation, if available.
- Store the equipment in appropriate static-safe packaging when not in use.

## Electrical Safety Consideration



**ATTENTION:** Power to this equipment and all connected I/O must be supplied from a source compliant with the following:

- Limited Voltage Supply compliant with UL508.



**ATTENTION:**

- If this equipment is used in a manner that is not specified by the manufacturer, the protection that is provided by the equipment may be impaired.
- Read this document and the documents that are listed in the Additional Resources section about installation, configuration, and operation of this equipment before you install, configure, operate, or maintain this product. Users are required to familiarize themselves with installation and wiring instructions and requirements of all applicable codes, laws, and standards.
- Installation, adjustments, putting into service, use, assembly, disassembly, and maintenance are required to be carried out by suitably trained personnel in accordance with the applicable code of practice.  
In case of malfunction or damage, no attempts at repair should be made. The module should be returned to the manufacturer for repair. Do not dismantle the module.
- This equipment is certified for use only within the surrounding air temperature range of -20...+55 °C (-4...+131 °F). The equipment must not be used outside of this range.
- Use only a soft dry anti-static cloth to wipe down equipment. Do not use any cleaning agents.



**WARNING:**

- Secure any external connections that mate to this equipment by using screws, sliding latches, threaded connectors, or other means provided with this product.
- Do not disconnect equipment unless power has been removed or the area is known to be nonhazardous.
- The secondary of a current transformer shall not be open-circuited when applied in Class I, Zone 2 environments.

## Before You Begin

The 1732E-12X4M12QCDR, 1732E-12X4M12P5QCDR, 1732E-16CFGM12QCR, 1732E-16CFGM12P5QCR, 1732E-16CFGM12QCWR ArmorBlock® I/O modules communicate via EtherNet/IP™. The sealed IP65, IP66, IP67, and IP69K housing of these modules requires no enclosure. The I/O modules have dual Ethernet ports and use an embedded Ethernet switch.

The modules have auxiliary power In and Out connectors. There is no need to house these modules in a secondary enclosure. The I/O modules support the QuickConnect feature, onboard nonvolatile memory for storing block-specific data such as Tool ID and counter value, and provide basic distributed I/O functionality.

See [Figure 1 on page 4](#) to familiarize yourself with parts of the module.

Figure 1 - Module Identification

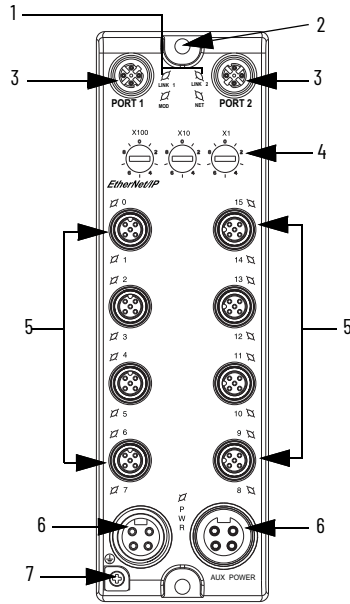

Component Description

	Description		Description
1	Status Indicators	5	M12 style I/O connectors
2	Functional Earth <sup>(1)</sup>	6	Auxiliary power
3	EtherNet/IP D-coded M12 connector	7	Protective Earth <sup>(2)</sup>
4	Node address switches		

(1) Functional Earth grounds the I/O block's EtherNet/IP communication circuitry, which is designed to mitigate the effect of noise on the network. See [EtherNet/IP Connector on page 7](#).

(2) Protective Earth is provided for the grounding of field devices and is internally connected to each Pin 5 of the M12 I/ connectors. See [I/O Connectors on page 6](#).

Table 1 lists the description of the module catalog numbers.

Table 1 - Catalog Number Explanation

Catalog Number	Description	Network Connector	Auxiliary Power
1732E-12X4M12QCDR	Diagnostic 12-input/4 output 24V DC digital I/O dual-port Ethernet module with QuickConnect	Dual D-coded M12	Dual 4-pin mini
1732E-12X4M12P5QCDR	Diagnostic 12-input/4 output 24V DC digital I/O dual-port Ethernet module with QuickConnect		Dual 5-pin mini
1732E-16CFGM12QCR	16-channel 24V DC self-configurable digital I/O dual-port Ethernet module with QuickConnect		Dual 4-pin mini
1732E-16CFGM12P5QCR	16-channel 24V DC self-configurable digital I/O dual-port Ethernet module with QuickConnect		Dual 5-pin mini
1732E-16CFGM12QCWR	16-channel 24V DC self-configurable digital I/O dual-port Ethernet metal WeldBlock module with QuickConnect		Dual 4-pin mini

Install the Module

To install the module:

- Set the network address
- Mount the module
- Connect the I/O, Network, and Auxiliary cables to the module.

Set the Network Address

The I/O block ships with the rotary switches set to 999 and DHCP enabled.

To change the network address, you can do one of the following:

- Adjust the switch on the front of the module.
- Use a Dynamic Host Configuration Protocol (DHCP) server, such as Rockwell Automation® BootP/DHCP.
- Retrieve the IP address from nonvolatile memory.

The I/O block reads the switches first to determine if the switches are set to a valid number. To set the network address:

1. Rotate the three switches on the front of the module with a small blade screwdriver.
2. Align the small notch on the switch with the number setting that you wish to use.
3. Valid settings range from 001...254.
4. Cycle power.

**Set Network Address**

The example shows the default node address set at 163.



When you set the switches to a valid number, the I/O block IP address is 192.168.1.xxx (where xxx represents the number set on the switches). The I/O block subnet mask is 255.255.255.0 and the gateway address is set to 0.0.0.0. When the I/O block uses the network address set on the switches, the I/O block does not have a host name assigned to it or use any Domain Name Server.

If you set the switches to an invalid number (for example, 000 or a value greater than 254 excluding 888), the I/O block checks to see if DHCP is enabled. If DHCP is enabled, the I/O block asks for an address from a DHCP server. The DHCP server also assigns other Transport Control Protocol (TCP) parameters.

If DHCP is not enabled, the I/O block uses the IP address (along with other TCP configurable parameters) stored in nonvolatile memory.

**Mount the Module**

Two sets of mounting holes are used to mount the module directly to a panel or machine. Mounting holes accommodate #8 (M4) pan head screws. The torque specification is 1.13 N•m (10 lb•in).

**Product Dimensions**

See [Figure 2](#) for the mounting dimensions illustration to help you mount the module.

**Figure 2 - Module Dimensions**

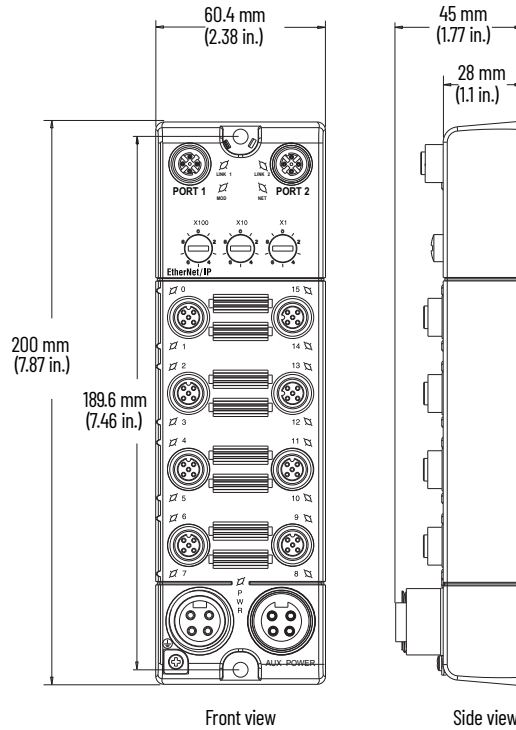

*Mount the Module in High Vibration Areas*

If you mount the module in an area that is subject to shock or vibration, we recommend you use a flat and a lock washer to mount the module. Mount the flat and the lock washer as shown in the mounting illustration. Torque the mounting screws to 1.13 N•m (10 lb•in).

Figure 3 - High Vibration Area Mounting

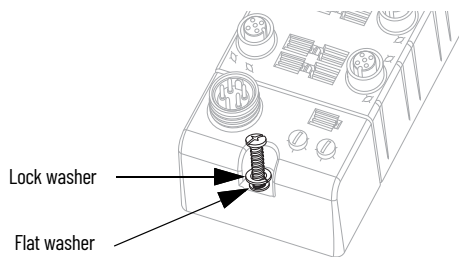

## Connect the I/O, Network, and Auxiliary Cables to the Module

The ArmorBlock EtherNet/IP family has 5-pin micro-style connectors. We provide caps to cover the unused connectors on your module. Connect the quick-disconnect patchcords that you selected for your module to the appropriate ports.

### I/O Connectors

See the pinout diagrams for the I/O connectors.

Figure 4 - Micro-style 5-pin Input Female Connector

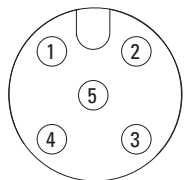

**For 1732E-12X4M12QCDR and 1732E-12X4M12P5QCDR only**

(View into connector)

- Pin 1 Sensor source voltage
- Pin 2 Input B
- Pin 3 Return
- Pin 4 Input A
- Pin 5 PE



**ATTENTION:** To comply with the CE Low Voltage Directive (LVD), this equipment and all connected I/O must be powered from a source compliant with the following:  
Safety Extra Low Voltage (SELV) or protected extra low voltage (PELV).

Figure 5 - Micro-style 5-pin Output Female Connector

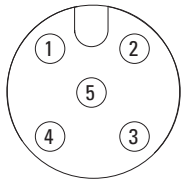

**For 1732E-12X4M12QCDR and 1732E-12X4M12P5QCDR only**

(View into connector)

- Pin 1 Not used
- Pin 2 Output B
- Pin 3 Return
- Pin 4 Output A
- Pin 5 PE

### Self-configuring Modules

The 1732E-16CFGM12QCR, 1732E-16CFGM12P5QCR, and 1732E-16CFGM12QCWR self-configuring modules contain both input and output functionality.

- If an I/O point is to be an output, dedicate that point as an output with a wired load and energize it through a control program.
- Energized outputs show an associated active input that can be used as a feedback mechanism to verify that the output is on.
- If an I/O point is to be an input, wire the input device as normal and leave the associated output de-energized always.

Figure 6 - Micro-style 5-pin Selectable Point Connector

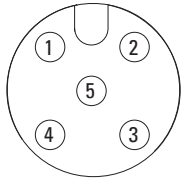

(View into connector)

- Pin 1 Sensor source voltage
- Pin 2 Input or Output B
- Pin 3 Return
- Pin 4 Input or Output A
- Pin 5 PE



**ATTENTION:** Make sure that all connectors and caps are securely tightened to seal the connections properly against leaks and maintain IP enclosure and NEMA type requirements.



**ATTENTION:** To comply with UL restrictions, this equipment must be powered from a source compliant with the following: Limited Voltage

Figure 7 - I/O Self-configure Circuitry

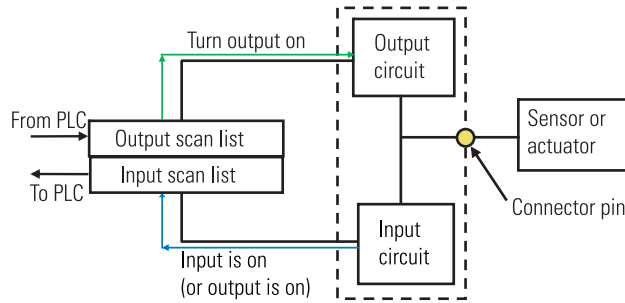

EtherNet/IP Connector

Figure 8 - D-coded Micro Network Female Connector

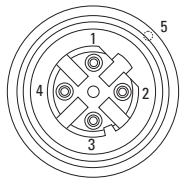

- Pin 1 M12\_Tx+
- Pin 2 M12\_Rx+
- Pin 3 M12\_Tx-
- Pin 4 M12\_Rx-
- Pin 5 Connector shell shield GND

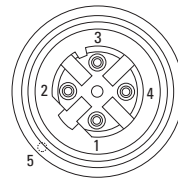

- Pin 1 M12\_Rx+
- Pin 2 M12\_Tx+
- Pin 3 M12\_Rx-
- Pin 4 M12\_Tx-
- Pin 5 Connector shell shield GND

**IMPORTANT**

Use the 1585D-M4DC-H: Polyamide small body unshielded or the 1585D-M4DC-SH: Zinc die-cast large body shielded mating connectors for the D-coded M12 female network connector.

**Enable QuickConnect**

To enable QuickConnect for the Ethernet ports, use the Studio 5000 Logix Designer® application Module QuickConnect tab and check the Enable QuickConnect option. For more information on the QuickConnect system setup, see EtherNet/IP QuickConnect Application Technique, publication [ENET-AT001](#).

After the QuickConnect feature is set to "on", the module must be power cycled. QuickConnect is active during the next connection.

Once active, the QuickConnect feature automatically sets all Ethernet ports to:

- Speed = 100 Mbps
- Duplex = Full
- Auto-negotiate = Off
- Automatic Cross-over Cable Detection (auto-MDIX) = Off

If you configure BOOTP or DHCP, QuickConnect changes the configuration to retain the current IP address. Disabling the QuickConnect feature automatically sets all Ethernet ports to Automatic Cross-over Cable Detection (auto-MDIX) = On.

To reset the Ethernet ports to Auto-negotiate or the IP address to DHCP request, you can:

- Change the setting on the module webpage.
- Change the setting in the Studio 5000 Logix Designer application.
- Perform a factory reset.

*Auxiliary Power Connector*

The 1732E-12X4M12QCDR, 1732E-16CFG12QCR, and 1732E-16CFG12QCWR modules use 4-pin auxiliary power connections. Attach the mini-style 4-pin connector to the mini-style 4-pin receptacle as shown [Figure 9](#).

Figure 9 - Mini-style 4-pin Receptacle

**Male Input**

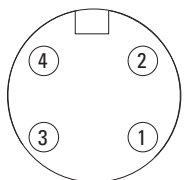

- (View into receptacle)
- Pin 1 Output power+
  - Pin 2 Sensor/MDL power+
  - Pin 3 Sensor/MDL power-
  - Pin 4 Output power-

**Female Output**

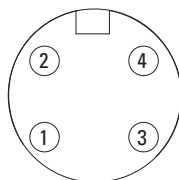

The 1732E-12X4M12P5QCDR, and 1732E-16CFGM12P5QCR modules use 5-pin auxiliary power connections. Attach the mini-style 5-pin connector to the mini-style 5-pin receptacle as shown in [Figure 10](#).

Figure 10 - Mini-style 5-pin Receptacle

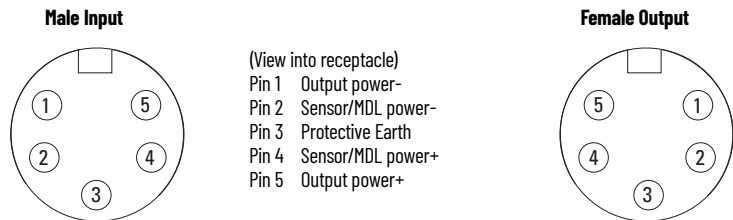

The ground for both module power and output power is shared.



**ATTENTION:** This equipment is considered Group 1, Class A industrial equipment according to IEC/CISPR 11. Without appropriate precautions, there may be difficulties with electromagnetic compatibility in residential and other environments due to conducted and radiated disturbance.

Auxiliary power is based on a 4-pin and 5-pin connector system and is used to provide 24V DC power to I/O modules and other devices. Running separate power to these devices is most typically used for I/O devices with output connections to help prevent power supply interruption due to switching of outputs. However, some devices require separate auxiliary power to power them regardless of the presence of outputs.

Depending on the devices used, it may be possible to provide power through only one pair of the four available pins, and in this case the other available pair may be used for single channel E-stop by using special E-stop drop or power T-ports and shorting plugs. Allen-Bradley® E-stop T-ports and shorting plugs are red for easy identification.

## Configure the Module

See [Figure 11](#) for configuration operations.

Figure 11 - Configure Operations

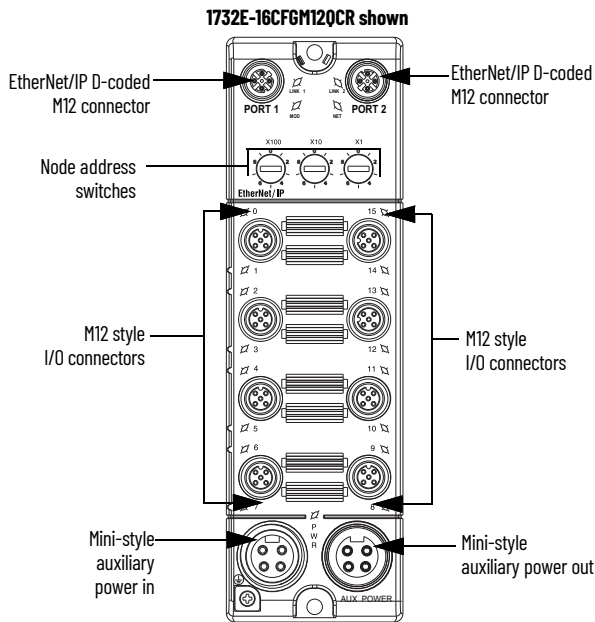

See Essential Components Selection Guide, publication [EC-CA100](#), for Rockwell Automation cable and patchcord offerings or use the configuration tools available at [rok.auto/systemtools](http://rok.auto/systemtools).

## External Repository for Random Data (ERRD)

The QuickConnect modules provide onboard nonvolatile memory, of up to 6 Kbytes, for storing block-specific data such as Tool ID and counter value. You can read from and write to the module memory.

### To read from the module

1. Send an EtherNet/IP Explicit Message with the following information:

Service Code	4C (hex)	
Class ID	6E (hex)	
Instance ID	1	
Attribute ID	1	
Request Data	Data Payload (total 8 bytes):	
	<b>Offset</b>	<b>Description</b>
	0x00	Address to Read from
	0x04	Number of bytes to read (max 472 bytes)

### To write to the module

2. Send the following three EtherNet/IP Explicit Messages:

Start Command	
Service Code	06 (hex)
Class ID	6E (hex)
Instance ID	1
Attribute ID	1

Write Command		
Service Code	4D (hex)	
Class ID	6E (hex)	
Instance ID	1	
Attribute ID	1	
Request Data	Data Payload (max 8+ 472 bytes):	
	<b>Offset</b>	<b>Description</b>
	0x00	Address to Write to
	0x04	Number of bytes to write (max 472 bytes)
	0x08	User Data (Array of USINT)

Stop Command	
Service Code	07 (hex)
Class ID	6E (hex)
Instance ID	1
Attribute ID	1

## Interpret Status Indicators

This module has the following indicators:

- Network, Module, and Link status indicators for EtherNet/IP
- Module Power indicator
- Individual I/O status indicators for inputs and outputs

Figure 12 - Status Indicators

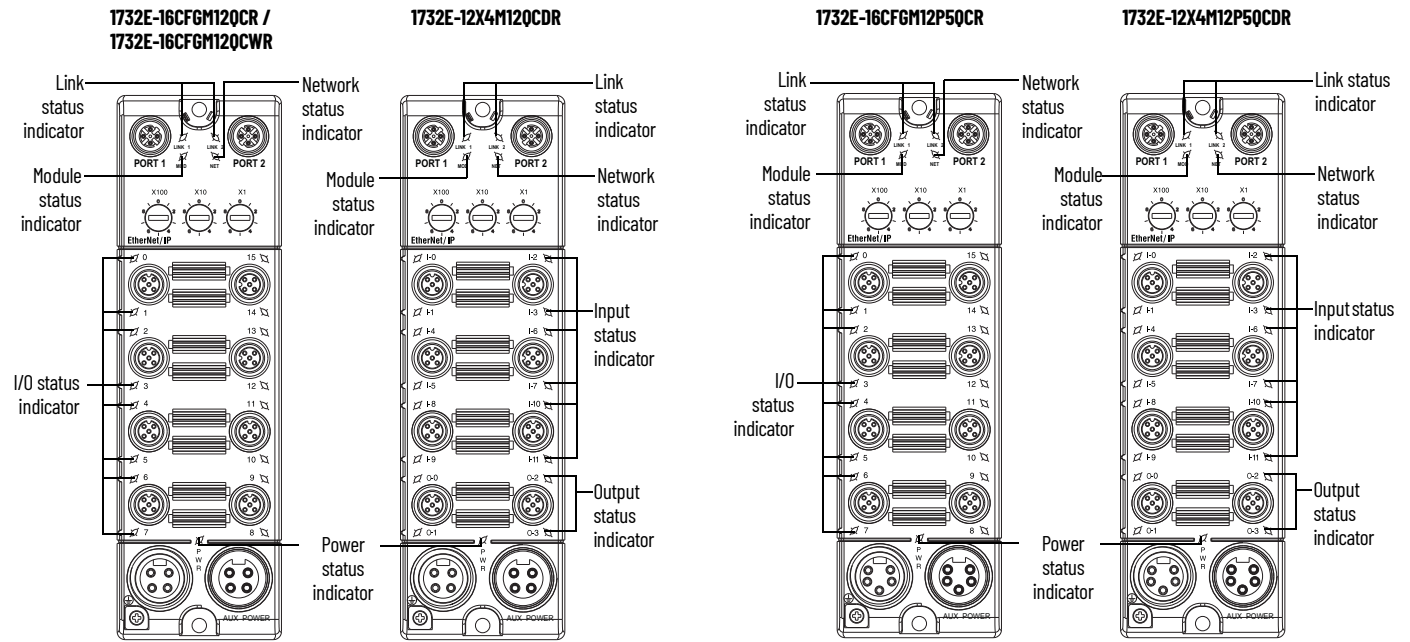

Indicator Status for Modules

Indicator	Status	Description
Module status	Off	No power is applied to the device.
	Flashing red/green	The module is performing Power-On self-test (POST), which completes within 30 s.
	Green	The device is operating normally.
	Flashing red	Recoverable fault
	Red	Unrecoverable fault - May require device replacement
Network status	Off	The device is not initialized or the module does not have an IP address.
	Flashing green	The device has no CIP™ connections. The device has an IP address, but no CIP connections are established.
	Green	The device is online, has an IP address, and CIP connections are established.
	Flashing red	One or more connections have timed out.
	Red	The module has detected that its IP address is already in use.
	Flashing red/green	The module is performing a powerup self-test.
Network link status	Off	No link is established.
	Green	Link is established on the indicated port at 100 Mbps.
	Flashing green	Link activity is present on the indicated port at 100 Mbps.
	Yellow	Link is established on the indicated port at 10 Mbps.
Power status	Flashing yellow	Link activity is present on the indicated port at 10 Mbps.
	Off	No power is applied to the device or input is not valid
Digital output status	Green	Power is applied to the device.
	Off	The output is not energized.
Digital input status	Yellow	The output is energized and output power is applied.
	Flashing yellow	The output is energized and there is no output power.
	Red <sup>(1)</sup>	The output is shorted.
	Flashing red	The output has an open load condition.
Digital input status	Off	No valid input
	Yellow	Valid input
	Red <sup>(1)</sup>	The sensor source voltage is shorted.
	Flashing red	The sensor source has an open wire condition.

(1) Only diagnostic modules 1732E-12X4M12QCDR and 1732E-12X4M12P5QCDR have red I/O status indicators.

**IMPORTANT**

In non-QuickConnect mode, the module status indicator flashes red and green for a maximum 5 s while the module completes its POST (Power-On self-test).

## Specifications

### Input Specifications

Attribute	1732E-12X4M12QCDR, 1732E-12X4M12P5QCDR	1732E-16CFG12QCR, 1732E-16CFG12P5QCR, 1732E-16CFG12QCWR
Number of inputs	12	16
Input type	Sink, 24V DC	
Voltage, off-state input, max	5V DC	
Voltage, on-state input, min	12V DC	
Voltage, on-state input, nom	24V DC	
Voltage, on-state input, max	30V DC	
Current, off-state input, max	1.5 mA @ 5V DC	
Current, on-state input, max	5 mA @ 30V DC	
Voltage, sensor source, min	10V DC	
Voltage, sensor source, max	30V DC	
Input delay time ON to OFF OFF to ON	0, 1, 2, 4, 8, 16 ms	

### Output Specifications

Attribute	1732E-12X4M12QCDR, 1732E-12X4M12P5QCDR	1732E-16CFG12QCR, 1732E-16CFG12P5QCR, 1732E-16CFG12QCWR
Number of outputs	4	16
Output type	Source, 24V DC	
Voltage drop, on-state output, max	0.5V DC	
Voltage off-peak blocking, min	30V DC	
Voltage, on-state output, min	12V DC	
Voltage, on-state output, nom	24V DC	
Voltage, on-state input, max	30V DC	
Current, on-state output, max	0.5 A	
Current per module, max	2.0 A	8.0 A
Leakage current, off-state output, max	0.5 mA	50 µA
Surge current per output, min	1.2 A for 10 ms, repeatable every 2 s	

### General Specifications

Attribute	1732E-12X4M12QCDR, 1732E-12X4M12P5QCDR	1732E-16CFG12QCR, 1732E-16CFG12P5QCR, 1732E-16CFG12QCWR
Voltage, auxiliary power, max	30V DC	
Voltage, auxiliary power, min	12V DC	
Current, Ethernet system power, max (pins 2, 3 sensor source/module power)	1.0 A	
Current, auxiliary power, max per output module (pins 2, 3 sensor source/module power plus pins 1, 4 for output loads)	2.0 A	8.0 A
Current, auxiliary power connector, per module, max	10 A	
Current, sensor source, per input, max	50 mA	
Current, sensor source, per connector, max	100 mA	
Communication rate	EtherNet/IP 10/100 Mbps Full or half-duplex 100 meters per segment	
Isolation voltage	50V (continuous), Basic Insulation Type, I/O to Ethernet, Power to Ethernet Type tested at 707V DC for 60 s	
Status indicators	Module status – red/green Network status – red/green Link status – green/yellow Auxiliary power – green I/O status – yellow	
	I/O status – yellow/red	N.A.

General Specifications (Continued)

Attribute	1732E-12X4M12QCDR, 1732E-12X4M12P5QCDR	1732E-16CFGM12QCR, 1732E-16CFGM12P5QCR, 1732E-16CFGM12QCWR
Dimensions (HxWxD), approx.	200 x 60.4 x 45 mm (7.87 x 2.38 x 1.77 in.)	
Weight, approx.	510 g (17.99 oz.)	430 g (15.17 oz.)
Wiring category <sup>(1)</sup> (2)	1 - on signal ports 1 - on power ports 1 - on communications port	
Enclosure type rating	Meets IP65/66/67/69K (when marked)	
Onboard memory type	Ferroelectric Nonvolatile RAM (FRAM)	
Onboard memory capacity, max	6 Kbytes	

(1) Use this conductor category information for planning conductor routing as described in Industrial Automation Wiring and Grounding Guidelines, publication [1770-4.1](#).

(2) Use this Conductor Category information for planning conductor routing as described in the appropriate System Level Installation Manual.

Environmental Specifications

Attribute	Value
Temperature, operating	IEC 60068-2-1 (Test Ad, Operating Cold), IEC 60068-2-2 (Test Bd, Operating Dry Heat), IEC 60068-2-14 (Test Nb, Operating Thermal Shock): -20...+60 °C (-4...+140 °F)
Temperature, ambient, max	60 °C (140 °F)
Temperature, surrounding air, max	60 °C (140 °F)
Temperature, nonoperating	IEC 60068-2-1 (Test Ab, Unpackaged Nonoperating Cold), IEC 60068-2-2 (Test Bb, Unpackaged Nonoperating Dry Heat), IEC 60068-2-14 (Test Na, Unpackaged Nonoperating Thermal Shock): -40...+85 °C (-40...+185 °F)
Relative humidity	IEC 60068-2-30 (Test Db, Unpackaged Damp Heat): 5...95% noncondensing
Vibration	IEC60068-2-6 (Test Fc, Operating): 5 g @ 10...500 Hz
Shock, operating	EC 60068-2-27 (Test Ea, Unpackaged Shock): 30 g
Shock, nonoperating	EC 60068-2-27 (Test Ea, Unpackaged Shock): 50 g
Emissions	CISPR 11 Group 1, Class A
ESD immunity	IEC6100-4-2: 6 kV contact discharges 8 kV air discharges
Radiated RF immunity	IEC 61000-4-3: 10V/m with 1 kHz sine wave-wave 80% AM from 80...2000 MHz 3V/m with 1 kHz sine wave 80% AM from 2000...2700 MHz
EFT/B immunity	IEC 61000-4-4: ±4 kV @ 5 kHz on power ports ±3 kV @ 5 kHz on signal ports ±3 kV @ 5 kHz on communications ports
Surge transient immunity	IEC 61000-4-5: ±1 kV line-line(DM) and ±2 kV line-earth(CM) on power ports ±1 kV line-line(DM) and ±2 kV line-earth(CM) on signal ports ±2 kV line-earth(CM) on communications ports
Conducted RF immunity	IEC61000-4-6: 10V rms with 1 kHz sine wave 80% AM from 150 kHz...80 MHz

## Certifications

Certification (when product is marked) <sup>(1)</sup>	Value
c-UR-us	UL Recognized Component Industrial Control Equipment, certified for US and Canada. See UL File E322657.
CE	European Union 2014/30/EU EMC Directive, compliant with: EN 61326-1; Meas./Control/Lab., Industrial Requirements EN 61000-6-2; Industrial Immunity EN 61131-2; Programmable Controllers EN 61000-6-4; Industrial Emissions  European Union 2011/65/EU RoHS, compliant with: EN IEC 63000; Technical documentation
RCM	Australian Radiocommunications Act, compliant with: AS/NZS CISPR11; Industrial Emissions.
KC	Korean Registration of Broadcasting and Communications Equipment, compliant with: Article 58-2 of Radio Waves Act, Clause 3
Morocco	Arrêté ministériel n° 6404-15 du 29 ramadan 1436
UKCA	2016 No. 1091 - Electromagnetic Compatibility Regulations 2012 No. 3032 - Restriction of the Use of Certain Hazardous Substances in Electrical and Electronic Equipment Regulations
EtherNet/IP	ODVA conformance tested to EtherNet/IP specifications.

(1) See the Product Certification link at [rok.auto/certifications](http://rok.auto/certifications) for Declaration of Conformity, Certificates, and other certification details.

## Additional Resources

For more information on the products that are described in this publication, use these resources. You can view or download publications at [rok.auto/literature](http://rok.auto/literature).

Resource	Description
ArmorBlock I/O Module Selection Guide, publication <a href="#">1732-SG001</a>	Provides information on how to select ArmorBlock I/O modules.
Ethernet Media Specifications Technical Data, publication <a href="#">1585-TD001</a>	Provides detailed specifications for Ethernet cordsets, patchcords, receptacles, cables, and cable accessories.
Cordsets and Field Attachables Technical Data, publication <a href="#">889-TD002</a>	Provides detailed specifications for cordsets, patchcords, field attachables, receptacles, distribution boxes, cables, and cable accessories.
Essential Components Selection Guide, publication <a href="#">EC-CA100</a>	Provides information on how to select Rockwell Automation cables and patchcords.
EtherNet/IP QuickConnect Application Technique, publication <a href="#">ENET-AT001</a>	Provides guidance and examples for configuring systems using EtherNet/IP QuickConnect.
Industrial Automation Wiring and Grounding Guidelines, publication <a href="#">1770-4.1</a>	More information on proper wiring and grounding techniques.
Product Certifications website, <a href="http://rok.auto/certifications">rok.auto/certifications</a>	Provides declarations of conformity, certificates, and other certification details.

## Rockwell Automation Support

Use these resources to access support information.

<b>Technical Support Center</b>	Find help with how-to videos, FAQs, chat, user forums, Knowledgebase, and product notification updates.	<a href="http://rok.auto/support">rok.auto/support</a>
<b>Local Technical Support Phone Numbers</b>	Locate the telephone number for your country.	<a href="http://rok.auto/phonesupport">rok.auto/phonesupport</a>
<b>Technical Documentation Center</b>	Quickly access and download technical specifications, installation instructions, and user manuals.	<a href="http://rok.auto/techdocs">rok.auto/techdocs</a>
<b>Literature Library</b>	Find installation instructions, manuals, brochures, and technical data publications.	<a href="http://rok.auto/literature">rok.auto/literature</a>
<b>Product Compatibility and Download Center (PCDC)</b>	Download firmware, associated files (such as AOP, EDS, and DTM), and access product release notes.	<a href="http://rok.auto/pcdc">rok.auto/pcdc</a>

## Documentation Feedback

Your comments help us serve your documentation needs better. If you have any suggestions on how to improve our content, complete the form at [rok.auto/docfeedback](http://rok.auto/docfeedback).





## Waste Electrical and Electronic Equipment (WEEE)



At the end of life, this equipment should be collected separately from any unsorted municipal waste.

Rockwell Automation maintains current product environmental compliance information on its website at [rok.auto/pec](http://rok.auto/pec).

Rockwell Otomasyon Ticaret A.Ş. Kar Plaza İş Merkezi E Blok Kat:6 34752 İçerenköy, İstanbul, Tel: +90 (216) 5698400 EEE Yönetmeliğine Uygundur

Connect with us.    

**rockwellautomation.com** — expanding **human possibility**<sup>®</sup>

AMERICAS: Rockwell Automation, 1201 South Second Street, Milwaukee, WI 53204-2496 USA, Tel: (1) 414.382.2000

EUROPE/MIDDLE EAST/AFRICA: Rockwell Automation NV, Pegasus Park, De Kleetlaan 12a, 1831 Diegem, Belgium, Tel: (32) 2663 0600

ASIA PACIFIC: Rockwell Automation SEA Pte Ltd, 2 Corporation Road, #04-05, Main Lobby, Corporation Place, Singapore 618494, Tel: (65) 6510 6608

UNITED KINGDOM: Rockwell Automation Ltd., Pitfield, Kiln Farm, Milton Keynes, MK11 3DR, United Kingdom, Tel: (44)(1908) 838-800

Allen-Bradley, ArmorBlock, expanding human possibility, FactoryTalk, Rockwell Automation, Studio 5000 Logix Designer, and TechConnect are trademarks of Rockwell Automation, Inc.

CIP and EtherNet/IP are trademarks of ODVA, Inc.

Trademarks not belonging to Rockwell Automation are property of their respective companies.

Publication 1732E-IN010F-EN-E - February 2024 | Supersedes Publication 1732E-IN010E-EN-E-November 2021

Copyright © 2024 Rockwell Automation, Inc. All rights reserved.