

# SIEMENS

## RUGGEDCOM RS900G

### Installation Guide

#### Preface

---

#### Introduction

---

1

#### Installing the Device

---

2

#### Device Management

---

3

#### Communication Ports

---

4

#### Technical Specifications

---

5

#### Certification

---

6

Copyright © 2019 Siemens Canada Ltd

All rights reserved. Dissemination or reproduction of this document, or evaluation and communication of its contents, is not authorized except where expressly permitted. Violations are liable for damages. All rights reserved, particularly for the purposes of patent application or trademark registration.

This document contains proprietary information, which is protected by copyright. All rights are reserved. No part of this document may be photocopied, reproduced or translated to another language without the prior written consent of Siemens Canada Ltd.

## » Disclaimer Of Liability

Siemens has verified the contents of this document against the hardware and/or software described. However, deviations between the product and the documentation may exist.

Siemens shall not be liable for any errors or omissions contained herein or for consequential damages in connection with the furnishing, performance, or use of this material.

The information given in this document is reviewed regularly and any necessary corrections will be included in subsequent editions. We appreciate any suggested improvements. We reserve the right to make technical improvements without notice.

## » Registered Trademarks

RUGGEDCOM™ and ROS™ are trademarks of Siemens Canada Ltd.

Other designations in this manual might be trademarks whose use by third parties for their own purposes would infringe the rights of the owner.

## » Third Party Copyrights

Siemens recognizes the following third party copyrights:

- Copyright © 2004 GoAhead Software, Inc. All Rights Reserved.

## » Security Information

Siemens provides products and solutions with industrial security functions that support the secure operation of plants, machines, equipment and/or networks. They are important components in a holistic industrial security concept. With this in mind, Siemens' products and solutions undergo continuous development. Siemens recommends strongly that you regularly check for product updates.

For the secure operation of Siemens products and solutions, it is necessary to take suitable preventive action (e.g. cell protection concept) and integrate each component into a holistic, state-of-the-art industrial security concept. Third-party products that may be in use should also be considered. For more information about industrial security, visit <https://www.siemens.com/industrialsecurity>.

To stay informed about product updates as they occur, sign up for a product-specific newsletter. For more information, visit <https://support.automation.siemens.com>.

## » Warranty

Siemens warrants this product for a period of five (5) years from the date of purchase, conditional upon the return to factory for maintenance during the warranty term. This product contains no user-serviceable parts. Attempted service by unauthorized personnel shall render all warranties null and void. The warranties set forth in this article are exclusive and are in lieu of all other warranties, performance guarantees and conditions whether written or oral, statutory, express or implied (including all warranties and conditions of merchantability and fitness for a particular purpose, and all warranties and conditions arising from course of dealing or usage or trade). Correction of nonconformities in the manner and for the period of time provided above shall constitute the Seller's sole liability and the Customer's exclusive remedy for defective or nonconforming goods or services whether claims of the Customer are based in contract (including fundamental breach), in tort (including negligence and strict liability) or otherwise.

For warranty details, visit <https://www.siemens.com/ruggedcom> or contact a Siemens customer service representative.

## » Contacting Siemens

### Address

Siemens Canada Ltd  
Industry Sector  
300 Applewood Crescent  
Concord, Ontario  
Canada, L4K 5C7

### Telephone

Toll-free: 1 888 264 0006  
Tel: +1 905 856 5288  
Fax: +1 905 856 1995

### E-mail

[ruggedcom.info.i-ia@siemens.com](mailto:ruggedcom.info.i-ia@siemens.com)

### Web

<https://www.siemens.com/ruggedcom>



# Table of Contents

Preface .....	vii
Alerts .....	vii
Related Documents .....	viii
Accessing Documentation .....	viii
Training .....	viii
Customer Support .....	viii
 Chapter 1	
<b>Introduction .....</b>	<b>1</b>
1.1 Feature Highlights .....	1
1.2 Description .....	2
1.3 Required Tools and Materials .....	3
1.4 Supported Fiber Optic Cables .....	3
1.5 Decommissioning and Disposal .....	4
 Chapter 2	
<b>Installing the Device .....</b>	<b>5</b>
2.1 General Procedure .....	5
2.2 Unpacking the Device .....	6
2.3 Cabling Recommendations .....	6
2.4 Installing the Device in Hazardous Locations .....	6
2.5 Mounting the Device .....	7
2.5.1 Mounting the Device on a DIN Rail .....	8
2.5.2 Mounting the Device to a Panel .....	9
2.6 Connecting the Failsafe Alarm Relay .....	10
2.7 Connecting Power .....	10
2.7.1 Connecting High AC/DC Power .....	11
2.7.2 Connecting Low DC Power .....	12
 Chapter 3	
<b>Device Management .....</b>	<b>15</b>
3.1 Connecting to the Device .....	15
3.2 Configuring the Device .....	16

## Chapter 4

<b>Communication Ports</b> .....	17
4.1 Copper Ethernet Ports .....	17
4.2 Fiber Optic Ethernet Ports .....	18
4.3 SFP Transceivers .....	19

## Chapter 5

<b>Technical Specifications</b> .....	21
5.1 Power Supply Specifications .....	21
5.2 Failsafe Alarm Relay Specifications .....	22
5.3 Copper Ethernet Port Specifications .....	22
5.4 Fiber Optic Ethernet Port Specifications .....	23
5.5 Operating Environment .....	23
5.6 Mechanical Specifications .....	24
5.7 Dimension Drawings .....	24

## Chapter 6

<b>Certification</b> .....	27
6.1 Approvals .....	27
6.1.1 CSA .....	27
6.1.2 European Union (EU) .....	28
6.1.3 FCC .....	29
6.1.4 FDA/CDRH .....	29
6.1.5 ISED .....	29
6.1.6 ACMA .....	29
6.1.7 RoHS .....	30
6.1.8 Other Approvals .....	30
6.2 EMC and Environmental Type Tests .....	30

# Preface

This guide describes the RUGGEDCOM RS900G. It describes the major features of the device, installation, commissioning and important technical specifications.

It is intended for use by network technical support personnel who are responsible for the installation, commissioning and maintenance of the device. It is also recommended for use by network and system planners, system programmers, and line technicians.

## CONTENTS

- [“Alerts”](#)
- [“Related Documents”](#)
- [“Accessing Documentation”](#)
- [“Training”](#)
- [“Customer Support”](#)

## Alerts

The following types of alerts are used when necessary to highlight important information.



### **DANGER!**

*DANGER alerts describe imminently hazardous situations that, if not avoided, will result in death or serious injury.*



### **WARNING!**

*WARNING alerts describe hazardous situations that, if not avoided, may result in serious injury and/or equipment damage.*



### **CAUTION!**

*CAUTION alerts describe hazardous situations that, if not avoided, may result in equipment damage.*



### **IMPORTANT!**

*IMPORTANT alerts provide important information that should be known before performing a procedure or step, or using a feature.*



### **NOTE**

*NOTE alerts provide additional information, such as facts, tips and details.*

## Related Documents

Other documents that may be of interest include:

- [RUGGEDCOM ROS User Guide](https://support.industry.siemens.com/cs/ww/en/view/109737198) [https://support.industry.siemens.com/cs/ww/en/view/109737198]

## Accessing Documentation

The latest user documentation for RUGGEDCOM RS900G is available online at <https://www.siemens.com/ruggedcom>. To request or inquire about a user document, contact Siemens Customer Support.

## Training

Siemens offers a wide range of educational services ranging from in-house training of standard courses on networking, Ethernet switches and routers, to on-site customized courses tailored to the customer's needs, experience and application.

Siemens' Educational Services team thrives on providing our customers with the essential practical skills to make sure users have the right knowledge and expertise to understand the various technologies associated with critical communications network infrastructure technologies.

Siemens' unique mix of IT/Telecommunications expertise combined with domain knowledge in the utility, transportation and industrial markets, allows Siemens to provide training specific to the customer's application.

For more information about training services and course availability, visit <https://www.siemens.com/ruggedcom> or contact a Siemens Sales representative.

## Customer Support

Customer support is available 24 hours, 7 days a week for all Siemens customers. For technical support or general information, contact Siemens Customer Support through any of the following methods:



### Online

Visit <http://www.siemens.com/automation/support-request> to submit a Support Request (SR) or check on the status of an existing SR.

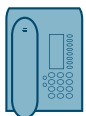

### Telephone

Call a local hotline center to submit a Support Request (SR). To locate a local hotline center, visit <http://www.automation.siemens.com/mcms/aspa-db/en/automation-technology/Pages/default.aspx>.



### Mobile App

Install the Industry Online Support app by Siemens AG on any Android, Apple iOS or Windows mobile device and be able to:

- Access Siemens' extensive library of support documentation, including FAQs and manuals
- Submit SRs or check on the status of an existing SR

- Contact a local Siemens representative from Sales, Technical Support, Training, etc.
- Ask questions or share knowledge with fellow Siemens customers and the support community



# 1 Introduction

The RUGGEDCOM RS900G is an industrially hardened, fully managed Ethernet switch providing dual fiber optical Gigabit Ethernet ports and eight Fast Ethernet copper ports.

Designed to operate reliably in harsh industrial environments, the RUGGEDCOM RS900G provides a high level of immunity to electromagnetic interference and heavy electrical surges typical of environments found in electric utility substations, factory floors or in curb side traffic control cabinets. An operating temperature range of -40 to 85 °C (-40 to 185 °F) coupled with hazardous location certification (Class I Division 2), optional conformal coating and a powder coated aluminum enclosure allows the RUGGEDCOM RS900G to be placed in almost any location.

The embedded RUGGEDCOM ROS (Rugged Operating System) provides advanced networking features such as Enhanced Rapid Spanning Tree (eRSTP), Port Rate Limiting and a full array of intelligent functionality for high network availability and manageability.

## CONTENTS

- [Section 1.1, "Feature Highlights"](#)
- [Section 1.2, "Description"](#)
- [Section 1.3, "Required Tools and Materials"](#)
- [Section 1.4, "Supported Fiber Optic Cables"](#)
- [Section 1.5, "Decommissioning and Disposal"](#)

## Section 1.1

# Feature Highlights

### Ethernet Ports

- 2 x 1000Base-X fiber optic ports
- 8 x 10/100Base-TX RJ45 ports
- Industry standard fiber optic connectors: LC, SC and SFP pluggable optics
- Bi-directional simplex fiber support
- Long haul optics allow Gigabit distances up to 70 km (43.5 mi)

### Rated for Reliability in Harsh Environments

- Immunity to EMI and heavy electrical surges
- Hazardous Location Certification: Class I Division 2
- -40 to 85°C (-40 to 185 °F) operating temperature (no fans)
- [Optional] Conformal coated printed circuit boards

### Universal Power Supply Options

- Fully integrated power supply
- Universal high-voltage range: 88-300 VDC or 85-264 VAC
- Dual low-voltage DC inputs: 24 VDC (10-36 VDC) or 48 VDC (36-72 VDC)
- Terminal blocks for reliable, maintenance-free connections
- CSA/UL 60950-1 safety approved to 85 °C (185 °F)

### Section 1.2

## Description

The RUGGEDCOM RS900G features various ports, controls and indicator LEDs on the front panel for connecting, configuring and troubleshooting the device.

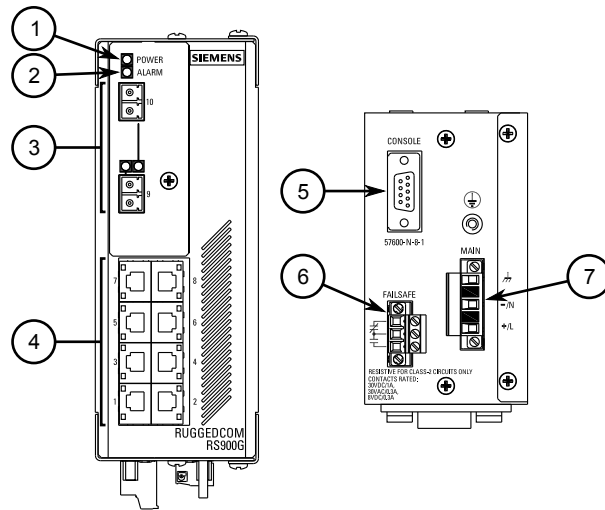

**Figure 1: RUGGEDCOM RS900G**

1. ALARM LED 2. POWER LED 3. Fiber Optic or SFP (Small Form-Factor Pluggable) Ethernet Ports 4. Copper Ethernet Ports 5. RS-232 Console Port (DB9) 6. Failsafe Alarm Relay 7. Power Supply Terminal Block

#### Communication Ports

Receive and transmit network traffic, as well as provide remote Web access to the RUGGEDCOM ROS operating system. For more information, refer to:

- [Section 3.1, "Connecting to the Device"](#)
- [Chapter 4, Communication Ports](#)

#### RS-232 Console Port

The serial console port is for interfacing directly with the device and accessing initial management functions. For information about connecting to the device via the serial console port, refer to [Section 3.1, "Connecting to the Device"](#).

#### POWER LED

Illuminates when power is being supplied to the device.

Color	Description
Green	Device is receiving power
Off	No power

<b>ALARM LED</b>	Illuminates when an alarm condition exists.
<b>Failsafe Alarm Relay</b>	Latches to default state when a power disruption or other alarm condition occurs. For more information, refer to: <ul style="list-style-type: none"> <li>• <a href="#">Section 2.6, "Connecting the Failsafe Alarm Relay"</a></li> <li>• <a href="#">Section 5.2, "Failsafe Alarm Relay Specifications"</a></li> </ul>
<b>Power Supply Terminal Block</b>	A pluggable terminal block. For more information, refer to: <ul style="list-style-type: none"> <li>• <a href="#">Section 2.7, "Connecting Power"</a></li> <li>• <a href="#">Section 5.1, "Power Supply Specifications"</a></li> </ul>

Section 1.3

## Required Tools and Materials

The following tools and materials are required to install the RUGGEDCOM RS900G:

Tools/Materials	Purpose
AC or DC power cord (16 AWG)	For connecting power to the device.
CAT-5 Ethernet cables	For connecting the device to the network.
#2 Phillips Flathead screwdriver	For mounting the device to a DIN rail.
Phillips screwdriver	For mounting the device to a panel.
4 x M3.5 (#6-32) screws	For mounting the device to a panel.

Section 1.4

## Supported Fiber Optic Cables

The following fiber optic cable types are supported under the stated conditions.

Cable Type	Wavelength (nm)	Modal Bandwidth (MHz-km)	Distance (m)		
			100Base-FX	1000Base-SX	10GBase-SR
OM1 (62.5/125)	850	200	—	275	33
	1300	500	2000	—	—
OM2 (50/125)	850	500	—	550	82
	1300	500	2000	—	—
OM3 (50/125) <sup>a</sup>	850	1500	—	550	300
	1300	500	2000	—	—
OM4 (50/125) <sup>a</sup>	850	3500	—	550	400
	1300	500	2000	—	—

<sup>a</sup> Laser optimized.

Section 1.5

# Decommissioning and Disposal

Proper decommissioning and disposal of this device is important to prevent malicious users from obtaining proprietary information and to protect the environment.

## » Decommissioning

This device may include sensitive, proprietary data. Before taking the device out of service, either permanently or for maintenance by a third-party, make sure it has been fully decommissioned.

For more information, refer to the associated *User Guide*.

## » Recycling and Disposal

For environmentally friendly recycling and disposal of this device and related accessories, contact a facility certified to dispose of waste electrical and electronic equipment. Recycling and disposal must be done in accordance with local regulations.

# 2 Installing the Device

This section describes how to install the device, including mounting the device, connecting power, and connecting the device to the network.



## DANGER!

*Electrocution hazard – risk of serious personal injury and/or damage to equipment. Before performing any maintenance tasks, make sure all power to the device has been disconnected and wait approximately two minutes for any remaining energy to dissipate.*



## IMPORTANT!

*This product contains no user-serviceable parts. Attempted service by unauthorized personnel shall render all warranties null and void.*

*Changes or modifications not expressly approved by RuggedCom Inc. could invalidate specifications, test results, and agency approvals, and void the user's authority to operate the equipment.*



## IMPORTANT!

*This product should be installed in a **restricted access location** where access can only be gained by authorized personnel who have been informed of the restrictions and any precautions that must be taken. Access must only be possible through the use of a tool, lock and key, or other means of security, and controlled by the authority responsible for the location.*

## CONTENTS

- [Section 2.1, "General Procedure"](#)
- [Section 2.2, "Unpacking the Device"](#)
- [Section 2.3, "Cabling Recommendations"](#)
- [Section 2.4, "Installing the Device in Hazardous Locations"](#)
- [Section 2.5, "Mounting the Device"](#)
- [Section 2.6, "Connecting the Failsafe Alarm Relay"](#)
- [Section 2.7, "Connecting Power"](#)

## Section 2.1

# General Procedure

The general procedure for installing the device is as follows:



## IMPORTANT!

*The user is responsible for the operating environment of the device, including maintaining the integrity of all protective conductor connections and checking equipment ratings. Make sure to review all*

*operating and installation instructions before commissioning or performing maintenance on the device.*

1. Review the relevant certification information for any regulatory requirements. For more information, refer to [Section 6.1, "Approvals"](#).
2. Mount the device.
3. Connect the failsafe alarm relay.
4. Connect power to the device and ground the device to safety Earth.
5. Connect the device to the network.
6. Configure the device.

## Section 2.2

# Unpacking the Device

When unpacking the device, do the following:

1. Inspect the package for damage before opening it.
2. Visually inspect each item in the package for any physical damage.
3. Verify all items are included.



### **IMPORTANT!**

*If any item is missing or damaged, contact Siemens for assistance.*

## Section 2.3

# Cabling Recommendations

Siemens does not recommend the use of copper cabling of any length for critical, real-time substation automation applications. All copper Ethernet ports on RUGGEDCOM products include transient suppression circuitry to protect against damage from electrical transients and conform with IEC 61850-3 and IEEE 1613 Class 1 standards. This means that during a transient electrical event, communications errors or interruptions may occur, but recovery is automatic.

Siemens also does not recommend using copper Ethernet ports to interface with devices in the field across distances that could produce high levels of ground potential rise (i.e. greater than 2500 V), during line-to-ground fault conditions.

## Section 2.4

# Installing the Device in Hazardous Locations

The RUGGEDCOM RS900G is designed to comply with the safety standards for Class I, Division 2 hazardous locations where concentrations of flammable gases, vapors or liquids may be present, as opposed to normal operating environments.



**IMPORTANT!**

*The device is certified for installation in hazardous environments as a component only. It is required to be installed in a suitable enclosure where the final combination is subject to acceptance by an authorized local inspection authority.*

Installation and use of the device in a hazardous location should meet the following special conditions for safe use:

- The device must be installed in a suitable enclosure
- Components must not be substituted for non-Siemens parts
- The device must not be disconnected unless the power has been turned off or the area is known to be non-hazardous
- The device must be appropriately connected to safety Earth upon installation



**NOTE**

*For further details of the device's compliance with Class I, Division 2 standards, refer to [Section 6.1, "Approvals"](#).*



**IMPORTANT!**

*Do not disconnect or open equipment unless power has been switched off or the area is known to be non-hazardous.*

**IMPORTANT !**

*Débrancher ou ouvrir l'équipement seulement si l'alimentation a été coupée ou si l'on sait que la zone ne pose aucun danger.*



**IMPORTANT!**

*Substitution of the components may impair suitability for Class I, Division 2.*

**IMPORTANT !**

*Le remplacement de composants pourrait compromettre l'admissibilité à la Classe I, Division 2.*

Section 2.5

## Mounting the Device

The RUGGEDCOM RS900G is designed for maximum mounting and display flexibility. It can be equipped with connectors that allow it to be installed in a 35 mm (1.4 in) DIN rail or directly on a panel.



**IMPORTANT!**

*Heat generated by the device is channeled outwards from the enclosure. As such, it is recommended that 2.5 cm (1 in) of space be maintained on all open sides of the device to allow for some convective airflow.*

*Forced airflow is not required. However, any increase in airflow will result in a reduction of ambient temperature and improve the long-term reliability of all equipment mounted in the rack space.*



**NOTE**

For detailed dimensions of the device with either DIN rail or panel hardware installed, refer to Section 5.7, "Dimension Drawings".

**CONTENTS**

- Section 2.5.1, "Mounting the Device on a DIN Rail"
- Section 2.5.2, "Mounting the Device to a Panel"

Section 2.5.1

## Mounting the Device on a DIN Rail

For DIN rail installations, the RUGGEDCOM RS900G can be equipped with a DIN rail bracket that allows the device to be slid onto a standard 35 mm (1.4 in) DIN rail.

To mount the device to a DIN rail, do the following:

1. Align the slot in the bracket with the DIN rail.

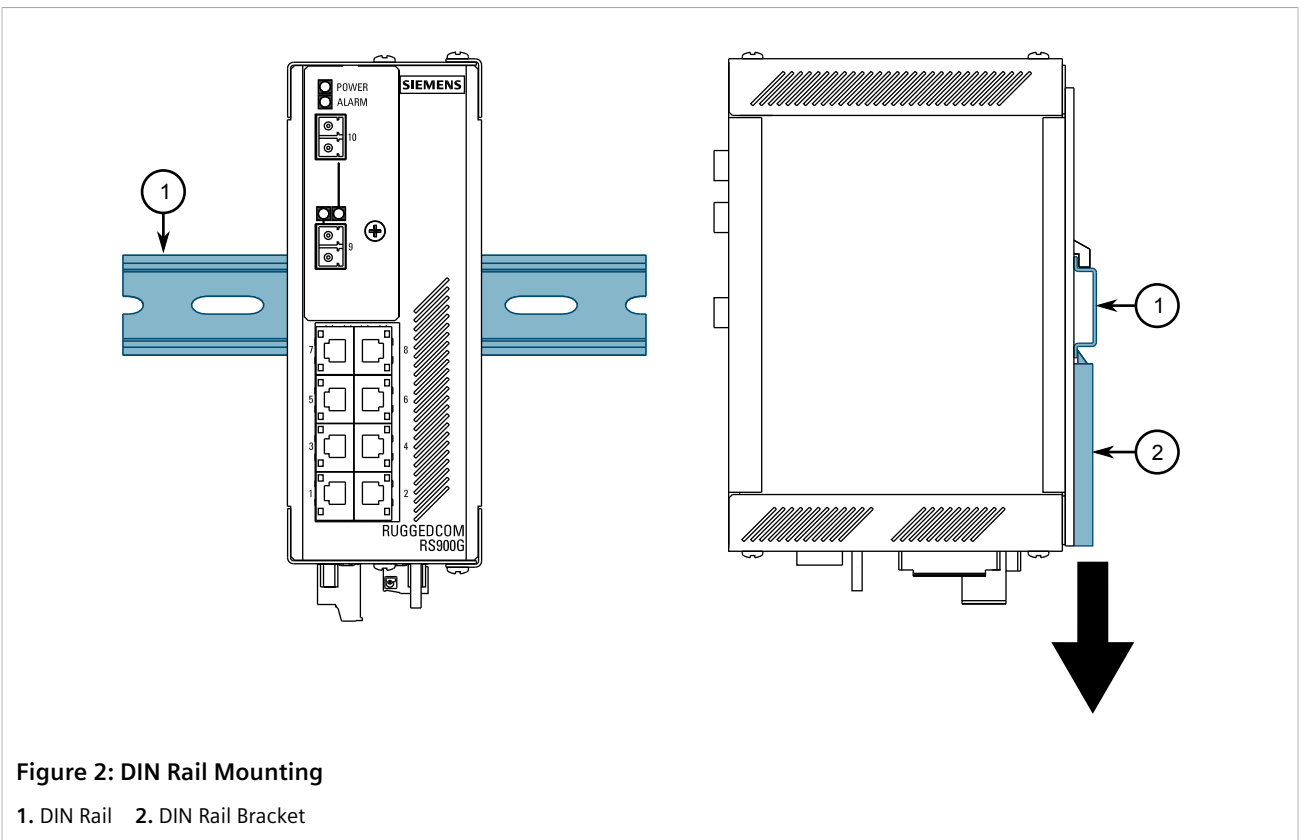

2. Pull the release on the bracket down and slide the device onto the DIN rail. Let go of the release to lock the device in position.

Section 2.5.2

## Mounting the Device to a Panel

For panel installations, the RUGGEDCOM RS900G can be equipped with panel adapters that allow the device to be attached to a panel using screws.

To mount the device to a panel, do the following:

1. Loosen the screws for the panel adapters located at the top and bottom of the device.

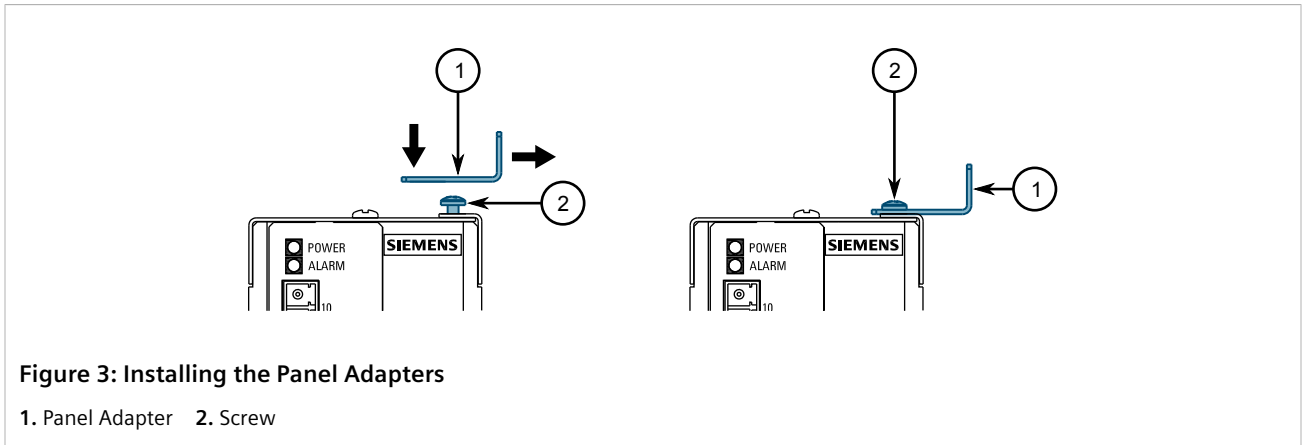

2. For both adapters, align the slots with the screws and then slide the adapters onto the device.
3. Tighten the screws to secure the adapters.
4. Place the device against the panel and align the adapters with the mounting holes.

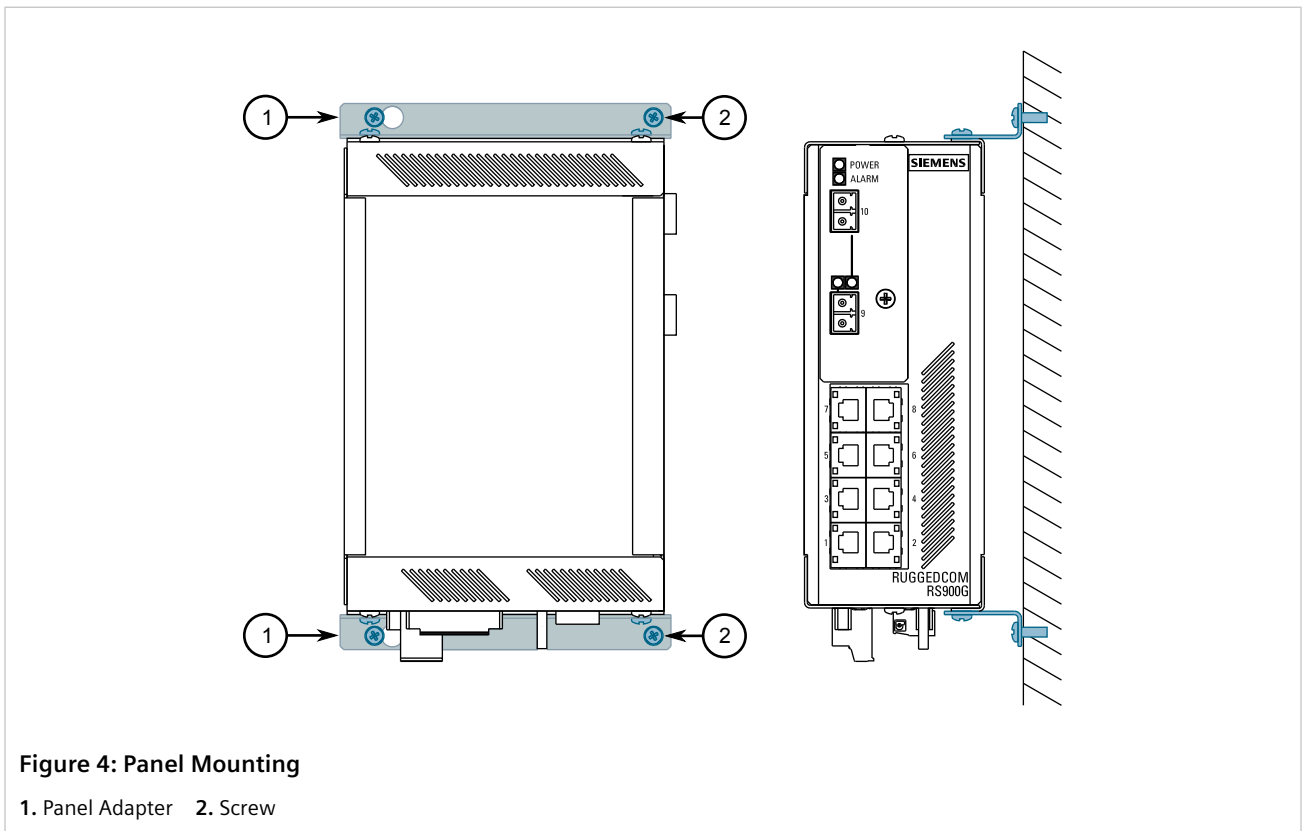

- Using two #6-32 screws for each adapter, secure the device to the panel.

## Section 2.6

# Connecting the Failsafe Alarm Relay

The failsafe relay can be configured to latch based on alarm conditions. The NO (Normally Open) contact is closed when the unit is powered and there are no active alarms. If the device is not powered or if an active alarm is configured, the relay opens the NO contact and closes the NC (Normally Closed) contact.



### NOTE

Control of the failsafe relay output is configurable through ROS. One common application for this relay is to signal an alarm if a power failure occurs. For more information, refer to the RUGGEDCOM ROS User Guide for the RUGGEDCOM RS900G.

The following shows the proper relay connections.

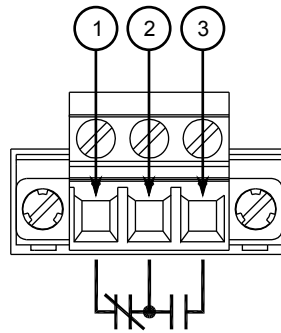

**Figure 5: Failsafe Alarm Relay Wiring**

1. Normally Closed 2. Common 3. Normally Open

## Section 2.7

# Connecting Power

The RUGGEDCOM RS900G features an integrated high AC/DC or low DC power supply that accepts input from redundant power sources.



### NOTE

Power sources can be connected to either power supply terminal block on the device.



### IMPORTANT!

- For 110/230 VAC rated equipment, an appropriately rated AC circuit breaker must be installed.
- For 125/250 VDC rated equipment, an appropriately rated DC circuit breaker must be installed.
- Use minimum #16 gage copper wiring when connecting terminal blocks.

- *Equipment must be installed according to applicable local wiring codes and standards.*

## CONTENTS

- [Section 2.7.1, "Connecting High AC/DC Power"](#)
- [Section 2.7.2, "Connecting Low DC Power"](#)

### Section 2.7.1

## Connecting High AC/DC Power

To connect a high AC/DC power supply to the device, do the following:



### CAUTION!

*Electrical hazard – risk of damage to equipment. Do not connect AC power cables to terminals for DC power. Damage to the power supply may occur.*



### CAUTION!

*Electrical hazard – risk of damage to equipment. Before testing the dielectric strength (HIPOT) in the field, remove the braided ground cable connected to the surge ground terminal and chassis ground. This cable connects transient suppression circuitry to chassis ground and must be removed to avoid damage to transient suppression circuitry during testing.*

1. Connect the positive wire from the power source to the positive/live (+/L) terminal on the terminal block.

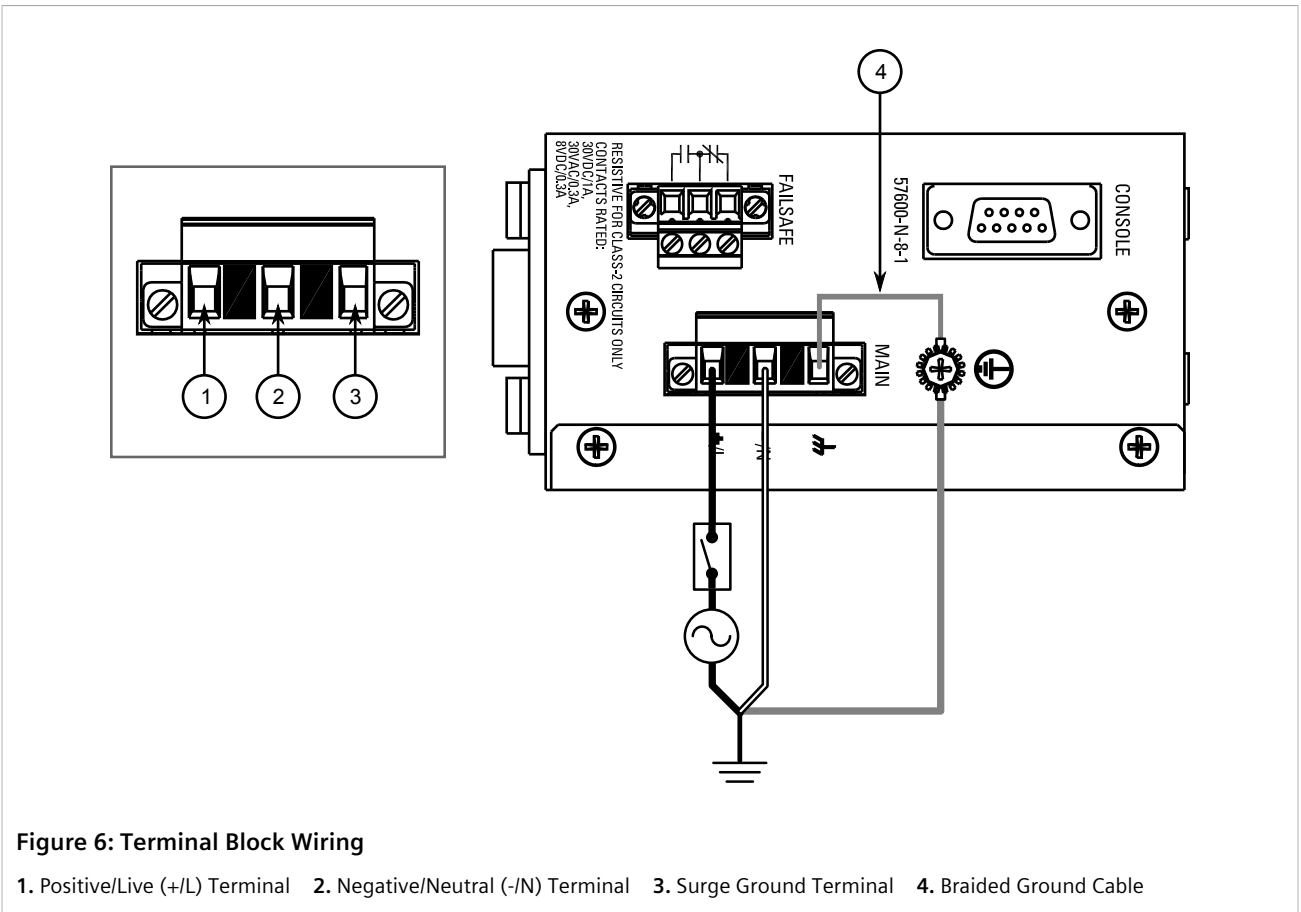

**Figure 6: Terminal Block Wiring**

1. Positive/Live (+/L) Terminal   2. Negative/Neutral (-/N) Terminal   3. Surge Ground Terminal   4. Braided Ground Cable

2. Connect the negative wire from the power source to the negative/neutral (-/N) terminal on the terminal block.
3. Using a braided wire or other appropriate grounding wire, connect the surge ground terminal to the chassis ground connection. The surge ground terminal is used as the ground conductor for all surge and transient suppression circuitry internal to the unit.
4. Connect the ground terminal on the power source to the chassis ground terminal on the device.

### Section 2.7.2

## Connecting Low DC Power

To connect a power source to the low DC power supply, do the following:



### CAUTION!

*Electrical hazard – risk of damage to equipment. Before testing the dielectric strength (HIPOT) in the field, remove the braided ground cable connected to the surge ground terminal and chassis ground. This cable connects transient suppression circuitry to chassis ground and must be removed to avoid damage to transient suppression circuitry during testing.*

1. Secure a European-style terminal block (or Euroblock) to one of the available terminals.
2. Connect the positive wire from the power source to the positive terminal on the terminal block.

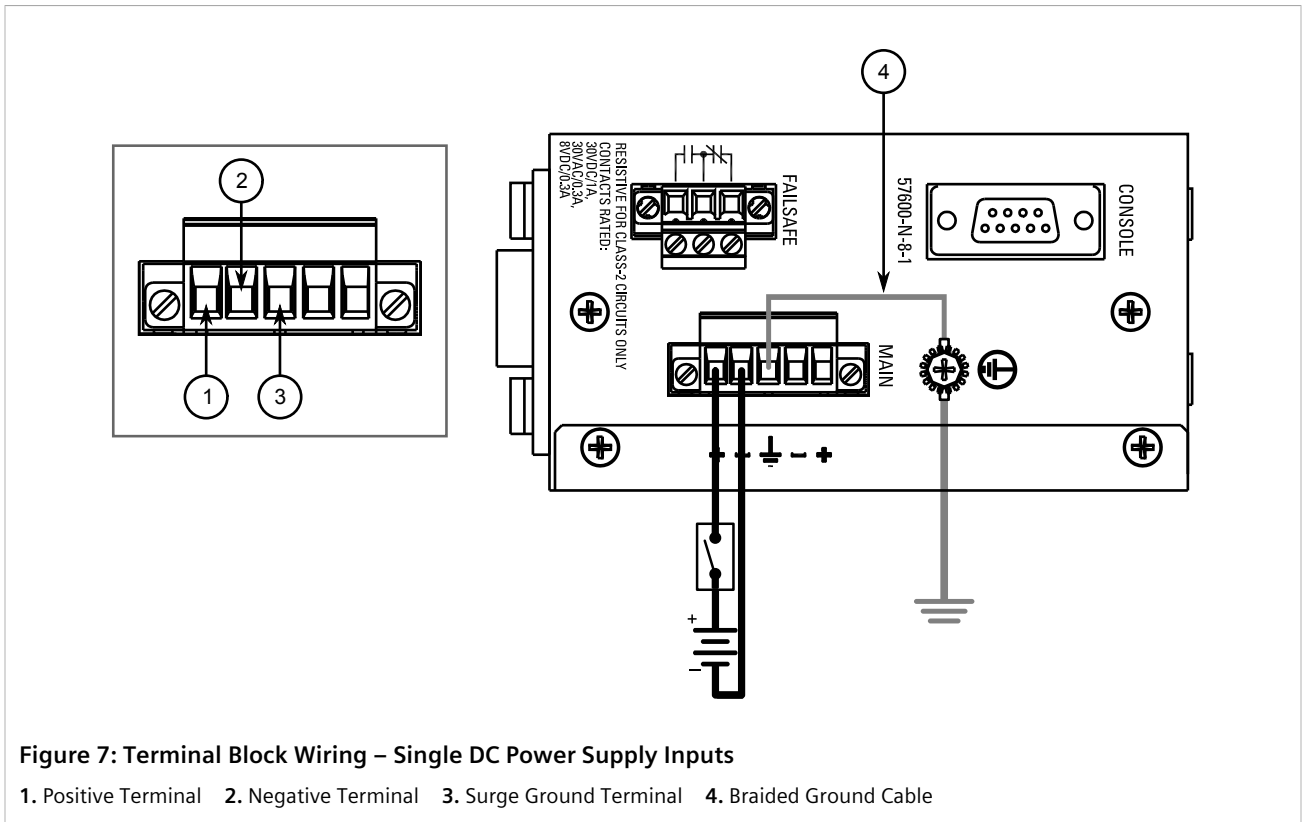

3. Connect the negative wire from the power source to the negative terminal on the terminal block.
4. Using a braided wire or other appropriate grounding wire, connect the surge ground terminal to the chassis ground connection. The surge ground terminal is used as the ground conductor for all surge and transient suppression circuitry internal to the unit.
5. Connect the ground terminal on the power source to the chassis ground terminal on the device.
6. If a redundant power source is required, repeat [Step 1](#) to [Step 5](#) using the second terminal.



# 3 Device Management

This section describes how to connect to and manage the device.

## CONTENTS

- [Section 3.1, "Connecting to the Device"](#)
- [Section 3.2, "Configuring the Device"](#)

### Section 3.1

## Connecting to the Device

The following describes the various methods for accessing the ROS console and Web interfaces on the device. For more detailed instructions, refer to the *RUGGEDCOM ROS User Guide* for the RUGGEDCOM RS900G.



### IMPORTANT!

*Ethernet cables should be only be connected/disconnected in a non-hazardous area, or when the device is not energized.*

### » Serial Console Port

Connect a PC or terminal directly to the serial console port to access the boot-time control and RUGGEDCOM ROS console interface.



### IMPORTANT!

*The serial console port is intended to be used only as a temporary connection during initial configuration or troubleshooting, and should only be used in a safe area (as defined by IEC 60079-0, Edition 6.0).*

The serial console port implements RS-232 DCE (Data Communication Equipment) on a DB9 connector. Use the following settings to connect to the port:

Speed	57600 baud
Data Bits	8
Stop Bit	1
Parity	None
Flow Control	Off
Terminal ID	VT100

The following is the pin-out for the port:

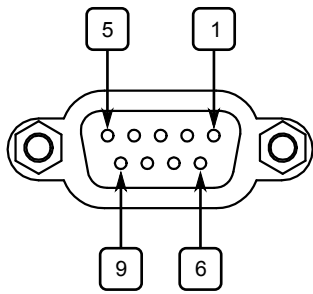

**Figure 8: Serial DB9 Console Port**

Pin	Name	Description
1 <sup>a</sup>		Reserved (Do Not Connect)
2	TX	Transmit Data
3	RX	Receive Data
4 <sup>a</sup>		Reserved (Do Not Connect)
5	GND	Signal Ground
6 <sup>a</sup>		Reserved (Do Not Connect)
7 <sup>b</sup>		Reserved (Do Not Connect)
8 <sup>b</sup>		Reserved (Do Not Connect)
9		Reserved (Do Not Connect)

<sup>a</sup> Connected internally.

<sup>b</sup> Connected internally.

## » Communication Ports

Connect any of the available Ethernet ports on the device to a management switch and access the RUGGEDCOM ROS console and Web interfaces via the device's IP address. The factory default IP address for the RUGGEDCOM RS900G is <https://192.168.0.1>.

For more information about available ports, refer to [Chapter 4, Communication Ports](#).

### Section 3.2

## Configuring the Device

Once the device is installed and connected to the network, it must be configured. All configuration management is done via the RUGGEDCOM ROS interface. For more information about configuring the device, refer to the *RUGGEDCOM ROS User Guide* associated with the installed software release.

# 4 Communication Ports

The RUGGEDCOM RS900G features eight standard 10/100Base-TX copper RJ45 Ethernet ports. It can also be equipped with two additional Gigabit Ethernet capable ports, for which many fiber transceiver and copper options are available.

Each communication port type has a specific place in the RUGGEDCOM RS900G chassis.

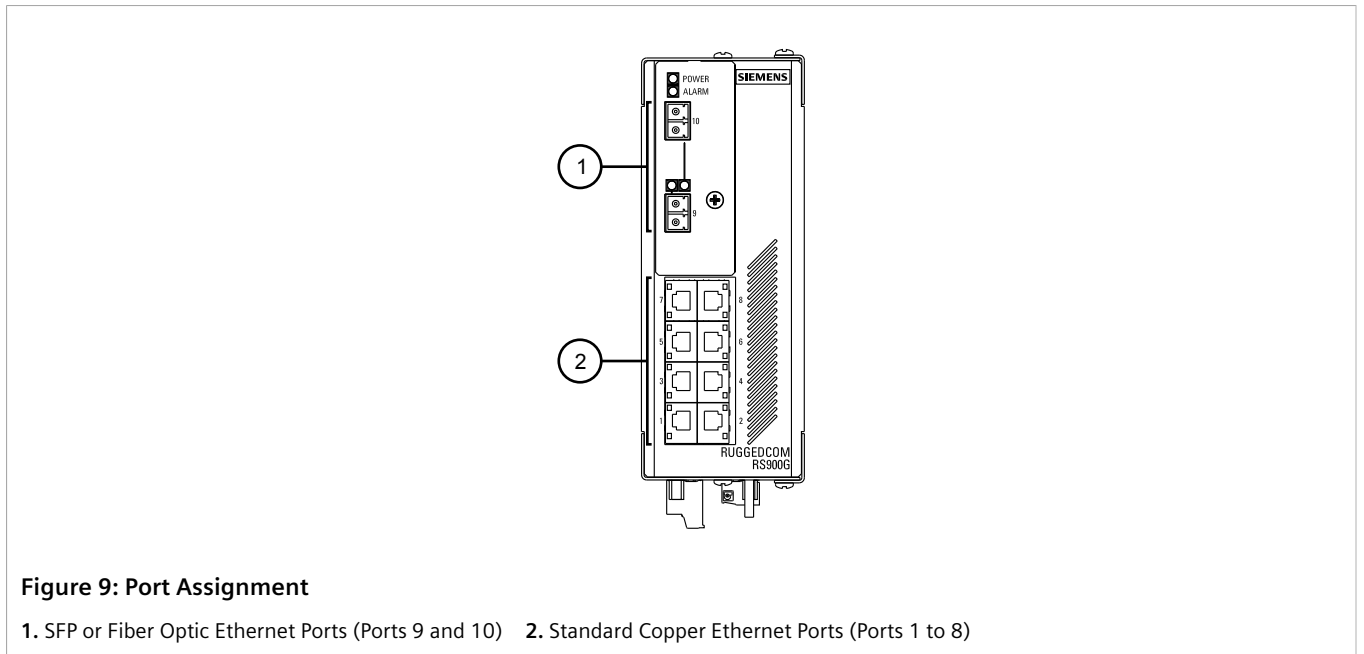

## CONTENTS

- [Section 4.1, "Copper Ethernet Ports"](#)
- [Section 4.2, "Fiber Optic Ethernet Ports"](#)
- [Section 4.3, "SFP Transceivers"](#)

### Section 4.1

## Copper Ethernet Ports

The RUGGEDCOM RS900G features eight 10/100Base-TX copper RJ45 Ethernet ports that allow connection to standard Category 5 (CAT-5) unshielded twisted-pair (UTP) cables with RJ45 male connectors. Each port is directly connected to the chassis ground on the device and can accept CAT-5 Unshielded Twisted-Pair (UTP) or Shielded Twisted-Pair (STP) cables.

**WARNING!**  
*Electric shock hazard – risk of serious personal injury and/or equipment interference. If shielded cables are used, make sure the shielded cables do not form a ground loop via the shield wire and the RJ45 receptacles at either end. Ground loops can cause excessive noise and interference, but more importantly, create a potential shock hazard that can result in serious injury.*

### » LEDs

Each port features an LED that indicates its link/activity state and current speed.

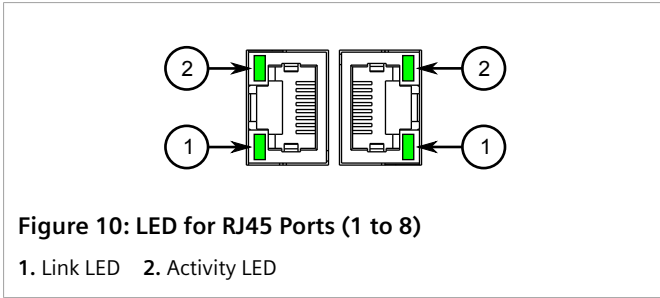

LED	State	Description
Link	Green	Link established
	Off	No link detected
Activity	Green (Blinking)	Link activity
	Off	No link activity

### » Pin-Out

The following is the pin-out description for the RJ45 connectors:

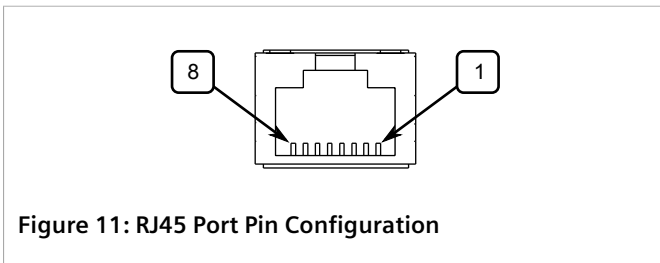

Pin	Name	Description
1	RX+	Receive Data+
2	RX-	Receive Data-
3	TX+	Transmit Data+
4	Reserved (Do Not Connect)	
5	Reserved (Do Not Connect)	
6	TX-	Transmit Data-
7	Reserved (Do Not Connect)	
8	Reserved (Do Not Connect)	

### » Specifications

For further specifications, refer to [Section 5.3, “Copper Ethernet Port Specifications”](#).

#### Section 4.2

## Fiber Optic Ethernet Ports

Optional 1000Base-SX and 1000Base-LX fiber optic Ethernet ports are available for ports 9 and 10 with either LC (Lucent Connector) and SC (Standard or Subscriber Connector) connectors. Make sure the Transmit (Tx) and Receive (Rx) connections of each port are properly connected and matched to establish a proper link.

### » Available Ports

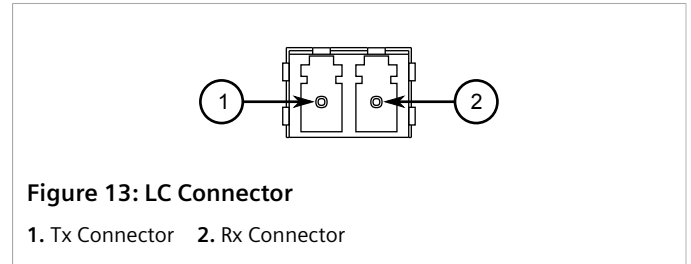
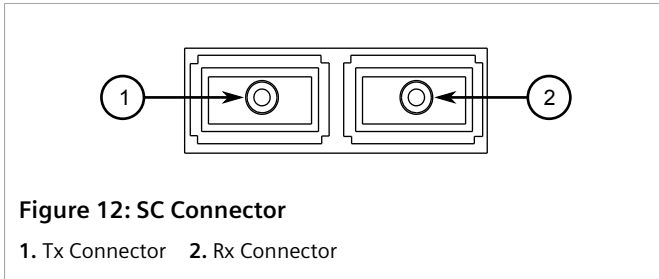

### » LEDs

Each port features an LED that indicates its link/activity state.

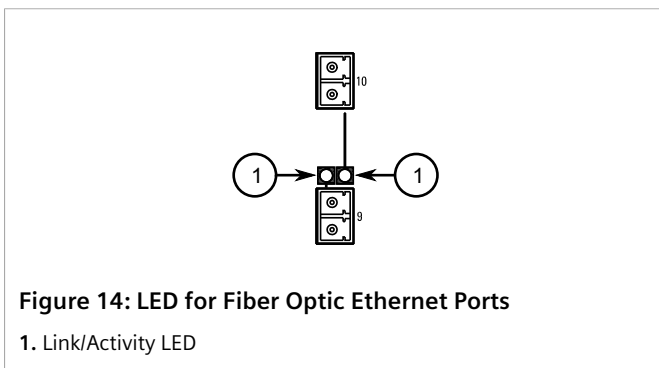

State	Description
Green (Solid)	Link established
Green (Blinking)	Link activity
Off	No link detected

### » Specifications

For further specifications, refer to [Section 5.4, "Fiber Optic Ethernet Port Specifications"](#).

#### Section 4.3

## SFP Transceivers

The RUGGEDCOM RS900G supports up to two Small Form-Factor Pluggable (SFP) transceiver sockets, which are compatible with a wide array of SFP transceivers available from Siemens.

### » LEDs

Each socket features an LED that indicates its link state.

State	Description
Green (Solid)	Link established
Green (Blinking)	Activity
Off	No link detected

## » Compatible SFP Transceivers

The following SFP transceivers are compatible with the RUGGEDCOM RS900G. For more information, including installation/removal instructions and ordering information, refer to the [RUGGEDCOM SFP Transceiver Catalog \[https://support.industry.siemens.com/cs/ca/en/view/109482309\]](https://support.industry.siemens.com/cs/ca/en/view/109482309).



### IMPORTANT!

*Only use SFP transceivers approved by Siemens for RUGGEDCOM products. Siemens accepts no liability as a result of performance issues related in whole or in part to third-party components.*

SFP Transceiver	Order Code	Speed (Mbit/s)	Mode <sup>a</sup>	Nominal Distance (km)
RUGGEDCOM SFP1112-1	6GK6000-8CG01-0AA0	10/100/1000	CAT-5e Copper	0.1
RUGGEDCOM SFP1132-1BX10R	6GK6000-8FB51-0AA0	1000	SM	10
RUGGEDCOM SFP1132-1BX10T	6GK6000-8FB52-0AA0	1000	SM	10
RUGGEDCOM SFP1132-1BX40R	6GK6000-8FB53-0AA0	1000	SM	40
RUGGEDCOM SFP1132-1BX40T	6GK6000-8FB54-0AA0	1000	SM	40
RUGGEDCOM SFP1122-1SX	6GK6000-8FG51-0AA0	1000	MM	0.5
RUGGEDCOM SFP1132-1LX10	6GK6000-8FG52-0AA0	1000	SM	10
RUGGEDCOM SFP1132-1LX25	6GK6000-8FG53-0AA0	1000	SM	25
RUGGEDCOM SFP1132-1LX40	6GK6000-8FG57-0AA0	1000	SM	40
RUGGEDCOM SFP1132-1LX70	6GK6000-8FG54-0AA0	1000	SM	70
RUGGEDCOM SFP1132-1LX100	6GK6000-8FG55-0AA0	1000	SM	100
RUGGEDCOM SFP1132-1LX115	6GK6000-8FE56-0AA0	1000	SM	115

<sup>a</sup> MM = Multi-Mode, SM = Single-Mode

# 5 Technical Specifications

This section provides important technical specifications related to the device.

## CONTENTS

- [Section 5.1, "Power Supply Specifications"](#)
- [Section 5.2, "Failsafe Alarm Relay Specifications"](#)
- [Section 5.3, "Copper Ethernet Port Specifications"](#)
- [Section 5.4, "Fiber Optic Ethernet Port Specifications"](#)
- [Section 5.5, "Operating Environment"](#)
- [Section 5.6, "Mechanical Specifications"](#)
- [Section 5.7, "Dimension Drawings"](#)

## Section 5.1

# Power Supply Specifications

## » Hazardous Environments

Power Supply Type	Input Range		Internal Fuse Rating <sup>a</sup>	Isolation	Maximum Power Consumption <sup>b</sup>
	Minimum	Maximum			
HI	125 VDC	250 VDC	3.15 A(T)	4 kVAC	10 W
	100 VAC	240 VAC	3.15 A(T)	4 kVAC	10 W
24	12 VDC	24 VDC	3.15 A(T)	1.5 kVDC	10 W
48	37 VDC	72 VDC	3.15 A(T)	1.5 kVDC	10 W

<sup>a</sup> (T) denotes time-delay fuse.

<sup>b</sup> Power consumption varies based on configuration.

## » Non-Hazardous Environments

Power Supply Type	Minimum Input	Maximum Input	Fuse Rating	Isolation	Maximum Power Consumption
12-24 VDC	10 VDC	36 VDC	3.15A (T) <sup>c</sup>	1.5 kVDC	10 W
24 VDC	18 VDC	36 VDC	3.15A (T) <sup>c</sup>	1.5 kVDC	
48 VDC	37 VDC	72VDC	3.15A (T) <sup>c</sup>	1.5 kVDC	

Power Supply Type	Minimum Input	Maximum Input	Fuse Rating	Isolation	Maximum Power Consumption
HI (125/250 VDC) <sup>d</sup>	88 VDC	300 VDC	3.15A (T) <sup>c</sup>	4 kVAC 5.5 kVDC	
HI (110/230 VAC) <sup>d</sup>	85 VAC	265 VAC			

<sup>c</sup> (T) denotes time-delay fuse

<sup>d</sup> This is the same power supply for both AC and DC.

Section 5.2

## Failsafe Alarm Relay Specifications



**NOTE**

The following specifications are for Class-2 circuits only.

Maximum Switching Voltage	Rated Switching Current	Isolation
30 VDC	1 A	1500 V <sub>rms</sub> for 1 minute
80 VDC	0.3 A	
30 VAC		

Section 5.3

## Copper Ethernet Port Specifications

The following details specifications for all standard and optional fixed copper Ethernet ports that can be ordered with the RUGGEDCOM RS900G. For more information about the SFP ports, refer to [Section 4.1, "Copper Ethernet Ports"](#).



**NOTE**

- Maximum segment length is greatly dependent on factors such as fiber quality, and the number of patches and splices. Consult a Siemens Sales associate when determining maximum segment distances.
- All optical power numbers are listed as dBm averages.
- F51 transceivers are rated for -40 to 85 °C (-40 to 185 °F).

Connector	Duplex <sup>e</sup>	Cable Type <sup>f</sup>	Wiring Standard <sup>g</sup>	Maximum Distance <sup>h</sup>	Isolation
RJ45	FDX/HDX	> CAT-5	TIA/EIA T568A/B	100 m (328 ft)	1.5 kV
micro-D	FDX/HDX	> CAT-5	TIA/EIA T568A/B	100 m (328 ft)	1.5 kV

<sup>e</sup> Auto-Negotiating.

<sup>f</sup> Shielded or unshielded.

<sup>g</sup> Auto-crossover and auto-polarity.

<sup>h</sup> Typical distance. Dependent on the number of connectors and splices.

Section 5.4

# Fiber Optic Ethernet Port Specifications

The following details specifications for all optional fixed fiber optic Ethernet ports that can be ordered with the RUGGEDCOM RS900G. For more information about the SFP ports, refer to [Section 4.2, "Fiber Optic Ethernet Ports"](#).



**NOTE**

- Maximum segment length is greatly dependent on factors such as fiber quality, and the number of patches and splices. Consult a Siemens Sales associate when determining maximum segment distances.
- All optical power numbers are listed as dBm averages. To convert from average to peak add 3 dBm. To convert from peak to average, subtract 3 dBm.
- All cabling is duplex type unless otherwise specified.

Mode	Connector Type	Cable Type (μm)	Tx λ (nm) <sup>i</sup>	Tx min (dBm)	Tx max (dBm)	Rx Sensitivity (dBm)	Rx Saturation (dBm)	Distance (km) <sup>i</sup>
MM	LC	50μ/125	850	-9.5	-4	-20	0	0.5
SM	LC	9μ/125	1310	-9.5	-3	-22	-3	10
SM	LC	9μ/125	1310	-5	0	-22	-3	25
SM	SC	9μ/125	1310	-10	-3	-22	-3	10
SM	SC	9μ/125	1310	-7	-3	-24	-3	25

<sup>i</sup> Typical.

Section 5.5

# Operating Environment

The RUGGEDCOM RS900G is rated to operate under the following environmental conditions.

<b>Ambient Operating Temperature<sup>k</sup></b>	-40 to 85 °C (-40 to 185 °F)
<b>Ambient Storage Temperature</b>	-40 to 85 °C (-40 to 185 °F)
<b>Ambient Relative Humidity<sup>l</sup></b>	5% to 95%
<b>Maximum Altitude<sup>m</sup></b>	2000 m (6562 ft)

<sup>j</sup> Measured from a 30 cm (12 in) radius surrounding the center of the RUGGEDCOM RS900G enclosure.

<sup>k</sup> Operating temperature may vary based on the limitations of installed SFPs. Refer to the RUGGEDCOM SFP Transceivers Catalog for SFP temperature ratings.

<sup>l</sup> Non-condensing

<sup>m</sup> Over temperature range of -40 to 85 °C (-40 to 185 °F)

Section 5.6

## Mechanical Specifications

<b>Weight</b>	1.2 kg (2.7 lbs)
<b>Ingress Protection</b>	IP30
<b>Enclosure</b>	20 AWG Galvanized Steel

Section 5.7

## Dimension Drawings



**NOTE**

*All dimensions are in millimeters, unless otherwise stated.*

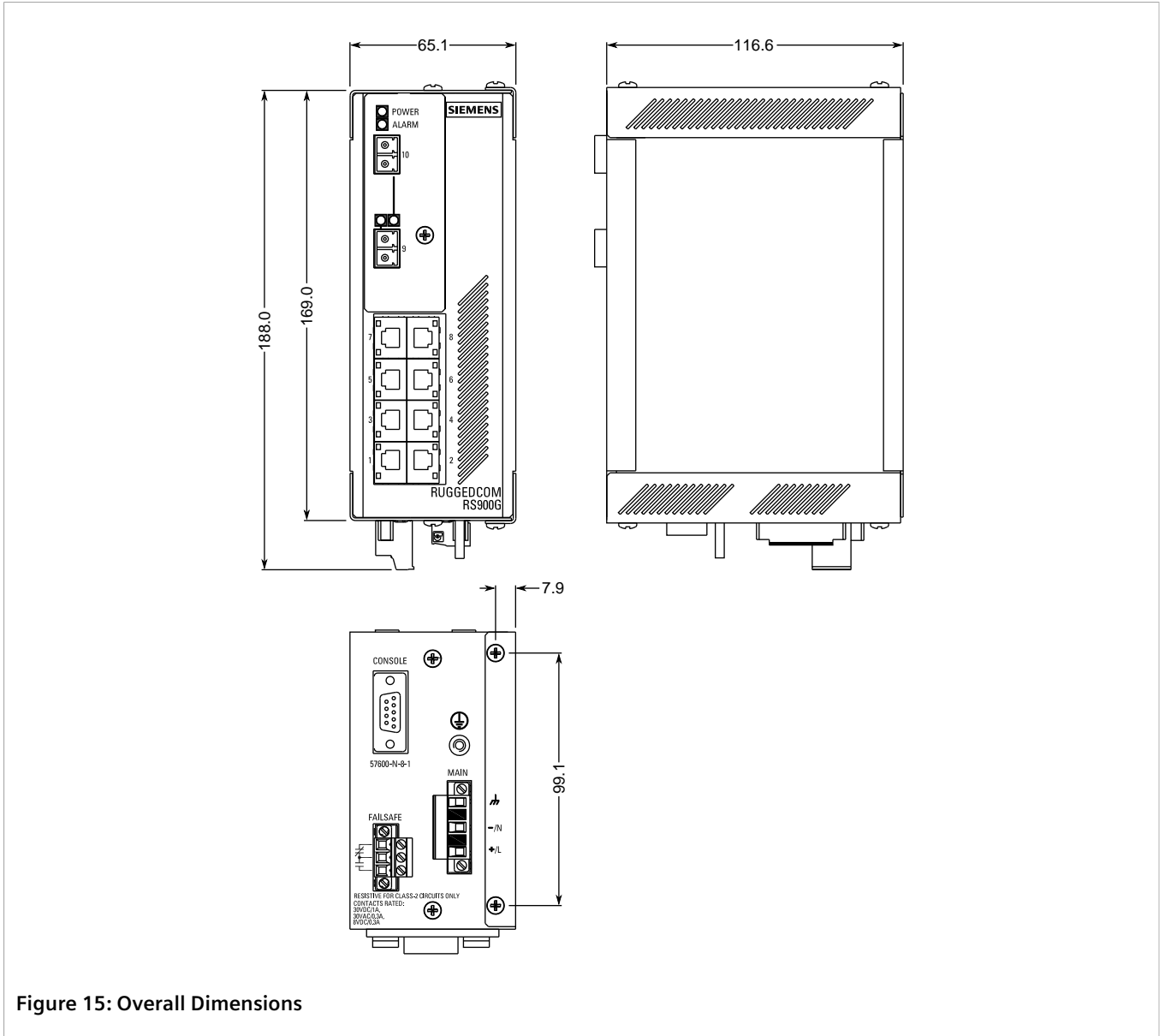

Figure 15: Overall Dimensions

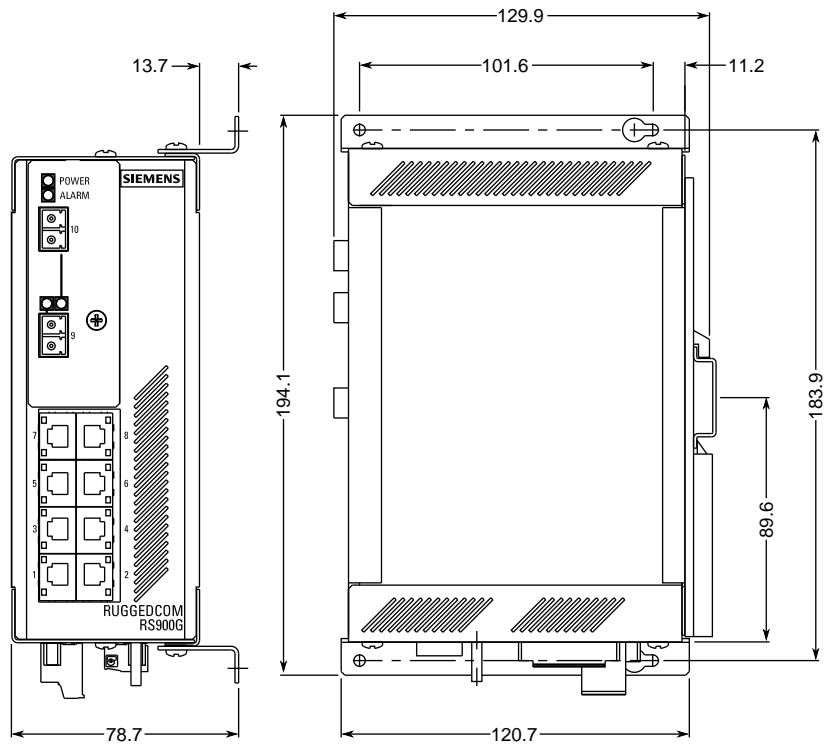

Figure 16: Panel and DIN Rail Mount Dimensions

# 6 Certification

The RUGGEDCOM RS900G device has been thoroughly tested to guarantee its conformance with recognized standards and has received approval from recognized regulatory agencies.

## CONTENTS

- [Section 6.1, "Approvals"](#)
- [Section 6.2, "EMC and Environmental Type Tests"](#)

### Section 6.1

## Approvals

This section details the standards to which the RUGGEDCOM RS900G complies.

## CONTENTS

- [Section 6.1.1, "CSA"](#)
- [Section 6.1.2, "European Union \(EU\)"](#)
- [Section 6.1.3, "FCC"](#)
- [Section 6.1.4, "FDA/CDRH"](#)
- [Section 6.1.5, "ISED"](#)
- [Section 6.1.6, "ACMA"](#)
- [Section 6.1.7, "RoHS"](#)
- [Section 6.1.8, "Other Approvals"](#)

### Section 6.1.1

## CSA

This device meets the requirements of the following Canadian Standards Association (CSA) standards under certificate 1550963:

- **CAN/CSA-C22.2 No. 60950-1**  
Information Technology Equipment – Safety – Part 1: General Requirements (Bi-National Standard, with UL 60950-1)
- **UL 60950-1**  
Information Technology Equipment – Safety Part 1: General Requirements
- **CAN/CSA-C22.2 No. 0-M91**  
General Requirements - Canadian Electrical Code, Part II

- **CAN/CSA-C22.2 No. 142-M1987**  
Process Control Equipment Industrial Products
- **CAN/CSA-C22.2 No. 213-16**  
Nonincendive Electrical Equipment for Use in Class I and II, Division 2 and Class III, Divisions 1 and 2 Hazardous (Classified) Locations (Bi-National Standard with ANSI/ISA-12.12.01-2016)
- **UL 916**  
Standard for Energy Management Equipment
- **ANSI/ISA-12.12.01-2015**  
Non-Incendive Electrical Equipment for Use in Class I and II, Division 2 and Class III, Division 1 and 2 Hazardous (Classified) Locations

The device is marked with a CSA symbol that indicates compliance with both Canadian and U.S. requirements.



It is specifically approved for use in hazardous locations defined as:

- Class I, Division 2, Groups A, B, C, D
- Temperature rating T6 at 40 °C and T4A at 85 °C

#### Section 6.1.2

## European Union (EU)

This device is declared by Siemens Canada Ltd to comply with essential requirements and other relevant provisions of the following EU directives:

- **EN 60950-1**  
Information Technology Equipment – Safety – Part 1: General Requirements
- **EN 61000-6-2**  
Electromagnetic Compatibility (EMC) – Part 6-2: Generic Standards – Immunity for Industrial Environments
- **EN 60825-1**  
Safety of Laser Products – Equipment Classification and Requirements
- **EN 50581**  
Technical Documentation for the Assessment of Electrical and Electronic Products with Respect to the Restriction of Hazardous Substances
- **EN 55022**  
Information Technology Equipment – Radio Disturbance Characteristics – Limits and Methods of Measurement

The device is marked with a CE marking and can be used throughout the European community.



A copy of the CE Declaration of Conformity is available from Siemens Canada Ltd. For contact information, refer to [“Contacting Siemens”](#).

Section 6.1.3

## FCC

This device has been tested and found to comply with the limits for a Class A digital device, pursuant to Part 15 of the FCC Rules. These limits are designed to provide reasonable protection against harmful interference when the equipment is operated in a commercial environment.

This device generates, uses and can radiate radio frequency energy and, if not installed and used in accordance with the instruction manual, may cause harmful interference to radio communications. Operation of this equipment in a residential area is likely to cause harmful interference in which case users will be required to correct the interference at their own expense.



**IMPORTANT!**

*Changes or modifications not expressly approved by the party responsible for compliance could void the user's authority to operate this device.*

Section 6.1.4

## FDA/CDRH

This device meets the requirements of the following U.S. Food and Drug Administration (FDA) standard:

- Title 21 Code of Federal Regulations (CFR) – Chapter I – Sub-chapter J – Radiological Health

Section 6.1.5

## ISED

This device is declared by Siemens Canada Ltd to meet the requirements of the following ISED (Innovation Science and Economic Development Canada) standard:

- CAN ICES-3 (A)/NMB-3 (A)

Section 6.1.6

## ACMA

This device meets the requirements of the following Australian Communications and Media Authority (ACMA) standards under certificate ABN 98 004 347 880:

- Radiocommunications (Compliance Labelling – Devices) Notice 2014 made under Section 182 of the Radiocommunications Act 1992
- Radiocommunications Labelling (Electromagnetic Compatibility) Notice 2008 made under Section 182 of the Radiocommunications Act 1992
- Radiocommunications (Compliance Labelling – Electromagnetic Radiation) Notice 2003 made under Section 182 of the Radiocommunications Act 1992
- Telecommunications Labelling (Customer Equipment and Customer Cabling) Notice 2001 made under Section 407 of the Telecommunication Act 1997

The device is marked with an RCM symbol to indicate compliance when sold in the Australian region.



A copy of the Declaration of Conformity is available via Siemens Industry Online Support at <https://support.industry.siemens.com/cs/ww/en/view/89855782>.

## Section 6.1.7

## RoHS

This device is declared by Siemens Canada Ltd to meet the requirements of the following RoHS (Restriction of Hazardous Substances) directives for the restricted use of certain hazardous substances in electrical and electronic equipment:

- **China RoHS 2**  
Administrative Measure on the Control of Pollution Caused by Electronic Information Products

A copy of the Material Declaration is available online at <https://support.industry.siemens.com/cs/ww/en/view/109738831>.

## Section 6.1.8

## Other Approvals

This device meets the requirements of the following additional standards:

- **EN50121-4**  
Railway applications – Electromagnetic Compatibility – Emission and Immunity of the Signaling and Telecommunications Apparatus

## Section 6.2

## EMC and Environmental Type Tests

The RUGGEDCOM RS900G has passed the following Electromagnetic Compatibility (EMC) and environmental tests.

### » EMC Type Tests

Test	Description	Test Levels	Severity Levels	
IEC 61000-4-2	ESD	Enclosure Contact	± 8 kV	4
		Enclosure Air	± 15 kV	4
IEC 61000-4-3	Radiated RFI	Enclosure Ports	10 V/m	3
IEC 61000-4-4	Burst (Fast Transient)	Signal Ports	± 4 kV	4
		DC Power Ports	± 4 kV	4
		AC Power Ports	± 4 kV	4

Test	Description		Test Levels	Severity Levels
		Earth Ground Ports	± 4 kV	4
IEC 61000-4-5	Surge	Signal Ports	± 4 kV Line-to-Earth ± 2 kV Line-to-Line	4
		DC Power Ports	± 4 kV Line-to-Earth ± 2 kV Line-to-Line	4
		AC Power Ports	± 4 kV Line-to-Earth ± 2 kV Line-to-Line	4
IEC 61000-4-6	Induced (Conducted) RFI	Signal Ports	10 V	3
		DC Power Ports	10 V	3
		AC Power Ports	10 V	3
		Earth Ground Ports	10 V	3
IEC 61000-4-8	Magnetic Field	Enclosure Ports	40 A/m Continuous 1000 A/m for 1 s	
IEC 61000-4-29	Voltage Dips and Interrupts	DC Power Ports	30% for 0.1 s 100% for 0.02 s 100% for 0.05 s	
		AC Power Ports	30% for 1 Period 60% for 50 Periods	
IEC 61000-4-11	Voltage Dips and Interrupts	AC Power Ports	100% for 5 Periods 100% for 50 Periods	
IEC 61000-4-12	Damped Oscillatory	Signal Ports	2.5 kV Common Mode @ 1 MHz 1 kV Differential Mode @ 1 MHz	3
		DC Power Ports	2.5 kV Common Mode @ 1 MHz 1 kV Differential Mode @ 1 MHz	3
		AC Power Ports	2.5 kV Common Mode @ 1 MHz 1 kV Differential Mode @ 1 MHz	3
IEC 60255-5	Dielectric Strength	Signal Ports	0.5 kV (Fail-Safe Relay output)	
		DC Power Ports	2 kV	
		AC Power Ports	2 kV	
IEC 60255-5	HV Impulse	Signal Ports	5 kV (Fail-Safe Relay output)	
		DC Power Ports	5 kV	
		AC Power Ports	5 kV	

## » EMC Immunity Type Tests per IEEE 1613



### NOTE

The RUGGEDCOM RS900G meets Class 2 requirements for an all-fiber configuration and Class 1 requirements for copper Ports. Class 1 allows for temporary communication loss, while Class 2 requires error-free and interrupted communications.

	Description	Test Levels
ESD	Enclosure Contact	± 8 kV
	Enclosure Air	± 15 kV
Radiated RFI	Enclosure Ports	35 V/m
Fast Transient	Signal Ports	± 4 kV @ 2.5 kHz
	DC Power Ports	± 4 kV
	AC Power Ports	± 4 kV
	Earth Ground Ports	± 4 kV
Oscillatory	Signal Ports	2.2 kV Common Mode @ 1 MHz
	DC Power Ports	2.5 kV Common and Differential Mode @ 1 MHz
	AC Power Ports	2.5 kV Common and Differential Mode @ 1 MHz
HV Impulse	Signal Ports	5 kV (Failsafe Relay)
	DC Power Ports	5 kV
	AC Power Ports	5 kV
Dielectric Strength	Signal Ports	0.5 kV (Failsafe Relay)
	DC Power Ports	2 kV
	AC Power Ports	2 kV

## » Environmental Type Tests

Test	Description	Test Levels	Severity Levels
IEC 60255-21-1	Vibration	2g @ 10-150 Hz	Class 2
IEC 60255-21-2	Shock	30g @ 11 ms	Class 2