

### Instructions

September, 1999

For Panel (1 - 4mm thick)  
(19 - 9 Gage Steel)

SFIS-10150-0999  
3SB3 (Sirius 3S)

①

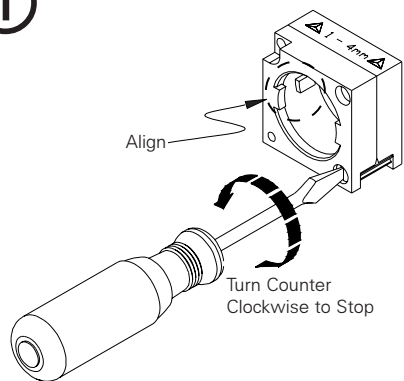

③

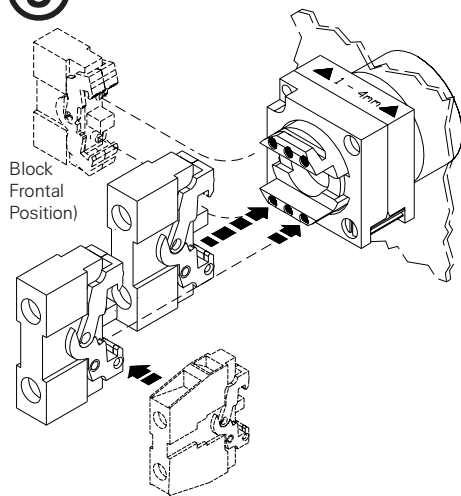

②

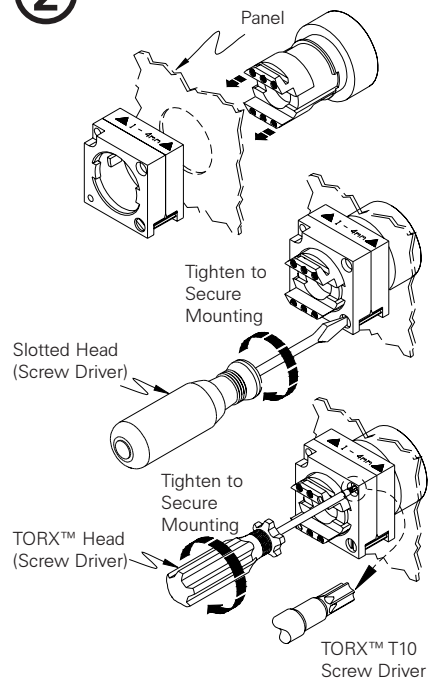

④

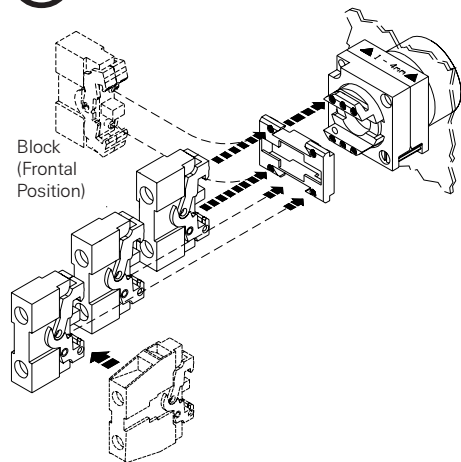

①

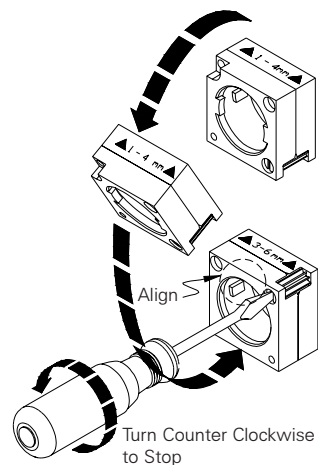

③

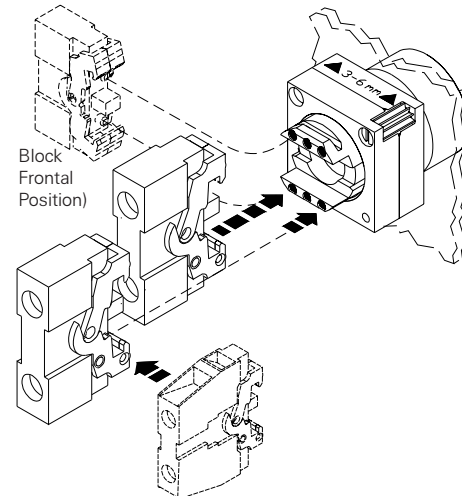

②

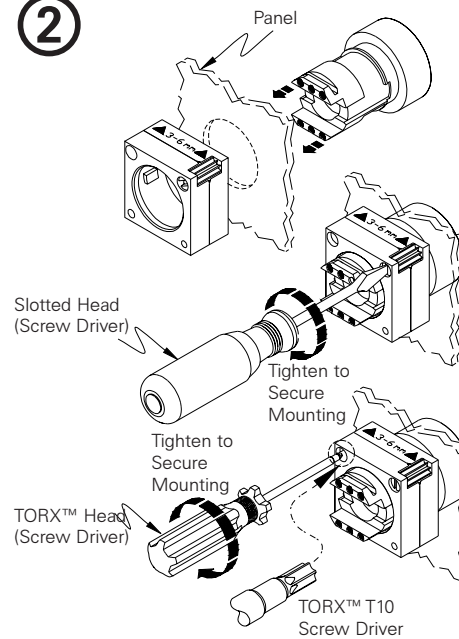

④

