

Commercial Products
Solar Combiner Solutions &
Sunnector™ Solar Cable Assemblies & Harnesses

CROUSE-HINDS
SERIES



Solar Solutions

Eaton's Crouse-Hinds provides the most complete third party listed balance of system offering of combiners, recombiners, disconnects, compact combiners, pass through boxes, solar cable assemblies, harnesses and balance of system accessories for your grid-tied solar applications.



Product solutions

engineered for solar applications

Eaton's Crouse-Hinds solar combiner boxes and recombiner boxes for the grid-tied solar market integrate a comprehensive line of electrical products with expert support, industry insights and local availability to improve safety and productivity in the most demanding industrial, commercial and residential environments worldwide.



Combiner Boxes with and without Integral Disconnects

Designed and built to minimize system costs by providing maximum flexibility and to perform in the harshest environmental conditions. Sizes range from 1 to 48 input circuits and are rated for either 600 or 1000 VDC applications. ETL listed to UL1741 standards, providing peace of mind and plenty of wiring room for ease of installation.



Disconnect Boxes

DC Safety Disconnect Boxes are used as a disconnecting means prior to the inverter and rated for either 600 or 1000 VDC applications. Disconnect Boxes range from 1 to 12 input circuits, with a wide range of disconnect sizes, configurations and enclosure options for maximum customer flexibility.



1500V Solar Combiner Boxes

1500 VDC Solar Combiner Boxes, available with or without Integral DC Disconnect Switches, are built to minimize system costs by reducing wiring, resulting in less labor. They are available with up to 36 input circuits and help save material costs, installation time and labor. ETL listed to UL1741 standard.



Solar Pass Through Boxes

NEMA 4X Pass Through Boxes are used in residential applications to provide a low profile, cost-effective way to group input wires/circuits from several arrays and/or solar panels and transition from solar (PV) cable to regular building wire. Sizes range from 3 to 36 input circuits and are rated for either 600 or 1000 VDC applications.



High Amperage Solar Combiner Boxes

Engineered, tested and third party certified for use in PV systems. Sizes range from 1 to 24 input circuits and are rated for either 600 or 1000 VDC applications. Designed with T-junction cable harnesses, high amperage boxes reduce installation labor, material costs and system maintenance.



Cable Harness Assemblies

Cable management options provide for all your bundling and harnessing of PV solar wires. Harnesses and cable assemblies are available in a variety of options to meet customer requirements. Harnesses and cable assemblies are rated for either 600, 1000 or 2000 VDC applications.



Compact (SL Series) Solar Combiners

Designed and built to provide long, dependable service in a low-profile, space-saving design. NEMA 4X compact combiners are third party listed to UL1741 and are available from factory stock in either 4 or 6 input circuits and are rated for 600 VDC applications with or without fuses to meet tight job delivery requirements.



Solar Accessories

Clips, Ties, Grips and Grounding Lugs are available in a variety of options to meet customer requirements.



Recombiner Boxes

In large PV systems, multiple combiner boxes are often necessary, and the outputs of these combiner boxes may need to be combined again (recombined) before reaching a central inverter. Recombiner Boxes allow for ease of installation, saving time, labor and most importantly, system costs. Solar Recombiners range from 2 to 12 input circuits and are rated for either 600 or 1000 VDC applications.

Grid-tied Solar System Information

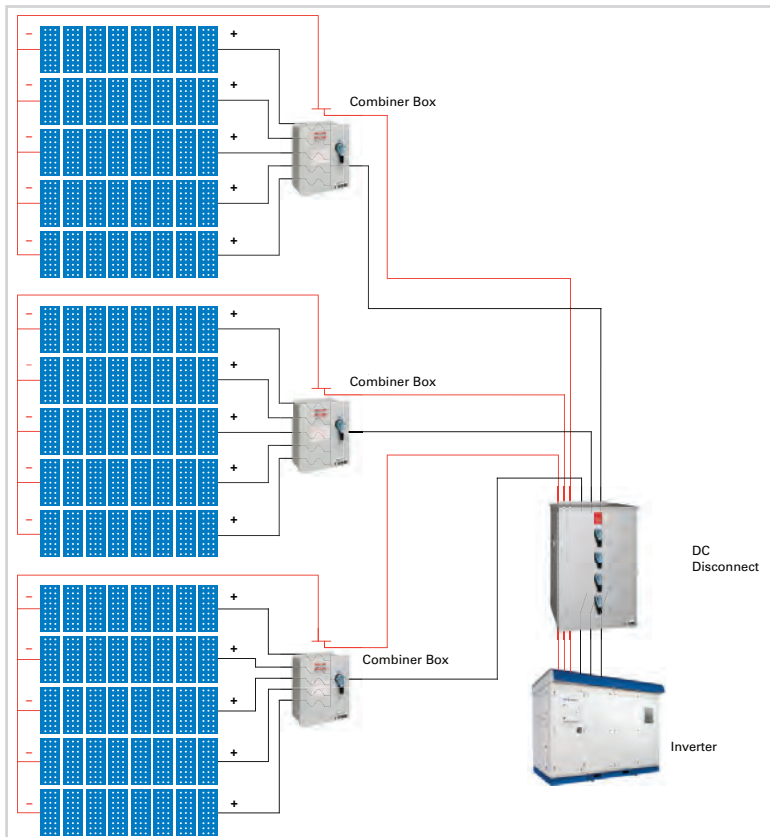

A grid-tied solar array may be a few panels or many in series, and may range from a few 12 volt panels to high voltage multi-panel arrays for grid-tied systems. Grid-tied systems can go as high as 1000 VDC, while off-grid battery systems are typically 12, 24 or 48V.

Higher voltage systems (over 48V) have different NEC code requirements than those for low voltage battery systems, and the two types are NOT interchangeable.

Eaton's Crouse-Hinds Series Solar Combiner Boxes are designed for higher voltage circuits used in grid-tied applications. All meet NEC requirements, are made in accordance with UL1741 standards, and are protected by Eaton's Bussmann® Series DC fuses specifically designed for the protection and isolation of photovoltaic strings.

DC Safety Disconnect Boxes are used as a disconnecting means prior to the inverter.

Typical Solar Grid-tied System Diagram

Eaton's Crouse-Hinds Series Solar Protection for Fiberglass Enclosures

Eaton's Crouse-Hinds series standard NEMA 4X Solar Combiner Boxes are shipped with fiberglass enclosures. These enclosures contain a solar protection formula that gives the enclosure strength and durability to provide long, dependable service even in the most demanding environmental conditions. They retain gloss and color even when exposed to harsh UV light and offer superior resistance to chemicals and are fire retardant.

A special UV absorber is added into this solar protection formula and works to absorb UV energy and release it without damaging the fiberglass enclosure, thus providing increased protection of the polyester material and increased resistance to the damaging effects of UV radiation. For additional information on Eaton's Crouse-Hinds series solar protection, choose fiberglass enclosures from: <http://www.crouse-hinds.com>.

How to size a Solar Combiner*:

1. Current Inputs:

a. Eaton provides a "Max. Short Circuit Current Rating per String" (Isc) for use as a direct comparison between the published Isc of the PV module. De-rating requirements per Article 690 of the NEC are applied and should be used to make a direct comparison with the PV module Isc ratings (i.e. CCBF12 has an Isc rating of 9.6A. PV modules with Isc ratings at or below 9.6A would be acceptable). For additional information, consult the electrical ratings table found in the technical section of this brochure.

2. Ratings:

a. Voltage: (600 VDC / 1000 VDC systems) – Eaton provides the total system voltage ratings to be used in comparison with the sum of the maximum number of modules in series per string. Consult NEC, ANSI and local codes when designing a system.

b. Current: Customer provided max. array current per string multiplied by number of combiner input circuits must be less than or equal to the max. current found in the electrical ratings table at the end of this section.

3. Hardware Sizing:

a. Integral Disconnect Switch Sizing: To determine the rating of the integral disconnect, simply multiply the number of input circuits by the max. current per string (as indicated above), and then round to the next (higher) disconnect size. In NO case can the maximum current exceed the amperage rating. Disconnect switches are rated for 100% continuous duty. Example: A 12-string combiner box with solar modules rated to 9.6A has a maximum current of 12A; 12A per string x 12 strings = 144A, which results in a 250A disconnect switch.

*The information above is provided for reference and information only. All statements, technical information and recommendations contained herein are based on information and tests we believe to be reliable. The accuracy or completeness thereof are not guaranteed. In accordance with Eaton's Crouse-Hinds Division's Terms and Conditions of Sale, and since conditions of use are outside our control, the purchaser should determine the suitability of the product for his/her intended use and assumes all risk and liability whatsoever in connection therewith.

Combiner Box Components and Features

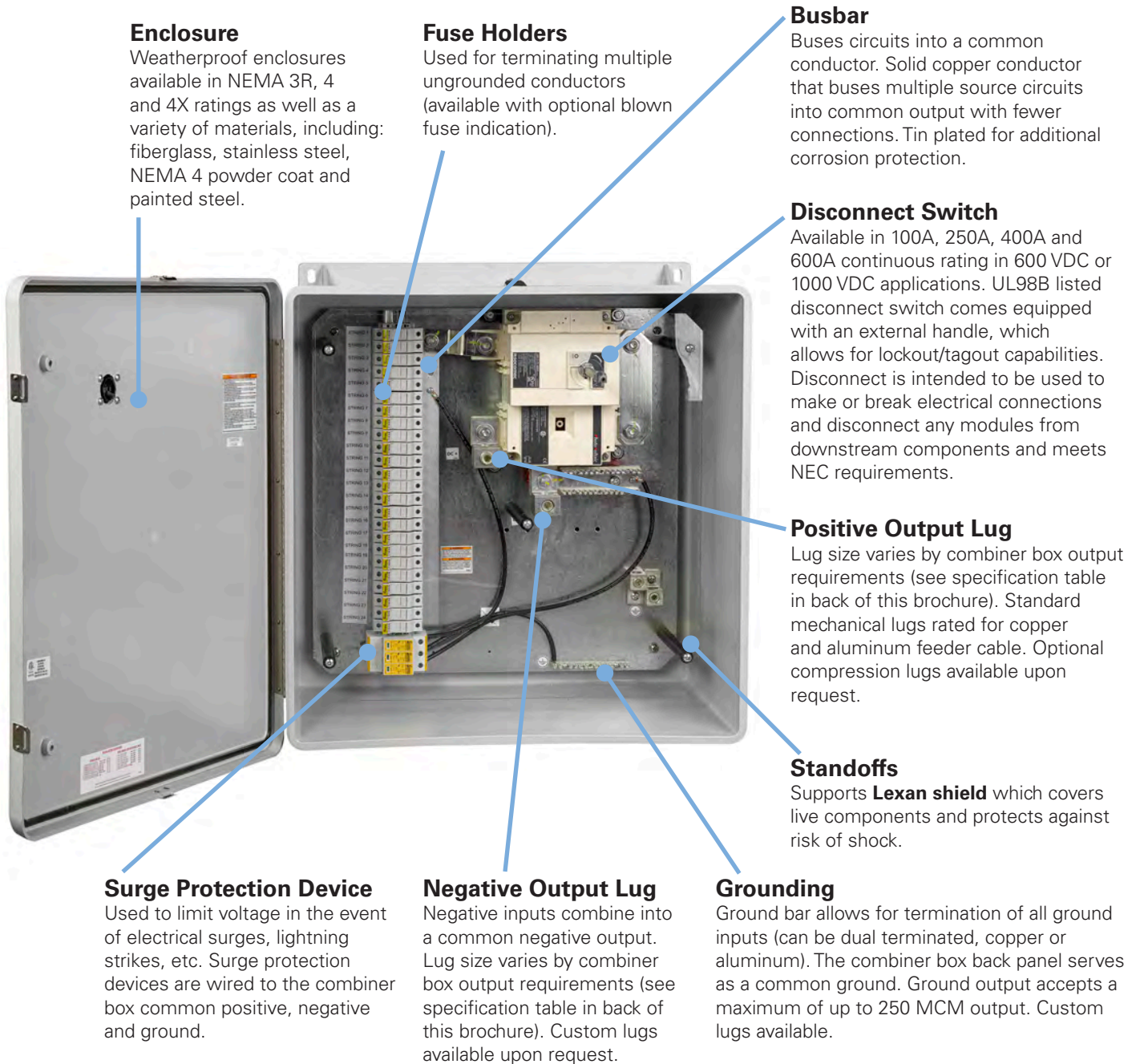

Enclosure

Weatherproof enclosures available in NEMA 3R, 4 and 4X ratings as well as a variety of materials, including: fiberglass, stainless steel, NEMA 4 powder coat and painted steel.

Fuse Holders

Used for terminating multiple ungrounded conductors (available with optional blown fuse indication).

Busbar

Buses circuits into a common conductor. Solid copper conductor that buses multiple source circuits into common output with fewer connections. Tin plated for additional corrosion protection.

Disconnect Switch

Available in 100A, 250A, 400A and 600A continuous rating in 600 VDC or 1000 VDC applications. UL98B listed disconnect switch comes equipped with an external handle, which allows for lockout/tagout capabilities. Disconnect is intended to be used to make or break electrical connections and disconnect any modules from downstream components and meets NEC requirements.

Positive Output Lug

Lug size varies by combiner box output requirements (see specification table in back of this brochure). Standard mechanical lugs rated for copper and aluminum feeder cable. Optional compression lugs available upon request.

Standoffs

Supports **Lexan shield** which covers live components and protects against risk of shock.

Surge Protection Device

Used to limit voltage in the event of electrical surges, lightning strikes, etc. Surge protection devices are wired to the combiner box common positive, negative and ground.

Negative Output Lug

Negative inputs combine into a common negative output. Lug size varies by combiner box output requirements (see specification table in back of this brochure). Custom lugs available upon request.

Grounding

Ground bar allows for termination of all ground inputs (can be dual terminated, copper or aluminum). The combiner box back panel serves as a common ground. Ground output accepts a maximum of up to 250 MCM output. Custom lugs available.

Options:

Integral connectors, whips and harnesses

Available as a pre-wired option for fast install and labor savings.

Current Monitoring

Can be added as an option. Incoming, ungrounded conductors (1 or 2) are fed through a single current transducer. Module configurations allow up to 12 string inputs. Note: Integration of this device typically increases enclosure size requirements.

See product pages for additional available options.



Current Monitoring

Custom Whips

Solar Combiner Boxes

Solar Combiner Boxes with and without Integral DC Disconnect Switches are built to minimize system costs by providing maximum flexibility. They are available with 1-48 input circuits* and help save material costs, installation time and labor when joining the combiner box and disconnect within one enclosure (eliminating the need for a disconnect switch in a separate enclosure). ETL listed to UL1741 standards*, providing peace of mind and plenty of wiring room for ease of installation.

Features:

- Rated for 600 VDC or 1000 VDC - continuous duty
- Optional integral disconnects available in 100A, 250A, 350A, 400A and 600A
- Touch-safe fuse holders
- Lexan shield covers all live components
- 90°C output terminals
- Configured for positive and negative grounded arrays**

Certifications and Compliances:

- cETLus 1741 Listed
- cETLus Listed to CSA Standard C22.2 No. 31 & No. 107.1
- NEMA 4X (fiberglass and stainless steel)
- NEMA 4 (powder coated steel)
- NEMA 3R (painted steel - for vertical mounting applications only)

Standard Materials and Finishes:

- NEMA 4X fiberglass (non-conductive, impact-resistant, UV-resistant, flame retardant) - natural
- NEMA 4X stainless steel - natural
- NEMA 4 steel - powder coated
- NEMA 3R steel (for vertical mounting applications only) - painted

Integral Disconnect Rating:

To determine the rating of the integral disconnect, simply multiply the number of input circuits by the max. current per string, and then round to the next (higher) disconnect size. In NO case can the maximum current exceed the amperage rating. Disconnect switches are rated for 100% continuous duty. Example: A 12-string combiner box with solar modules rated to 9.6A has a maximum current of 12A; 12A per string x 12 strings = 144A, which results in a 250A disconnect switch.

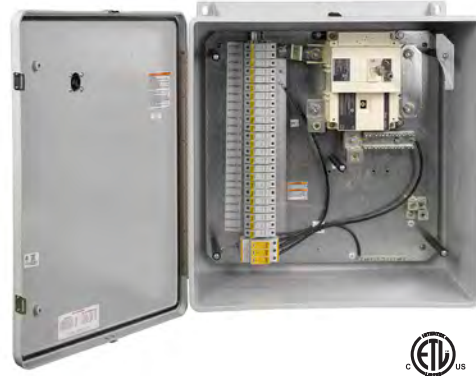

Options:

- Fuses (shipped uninstalled)
- Surge protection
- Solar cable whips (pre-assembled and installed) - see page 8
- Compression output lugs
- Factory installed breather vent or drain
- Bipolar construction (to 1000 VDC combined voltage)
- Smart combiners available (DC string monitoring)
- Factory drilled entrance holes
- Factory installed conduit fittings/cable glands
- Dual output lugs
- Lockable enclosures
- Integral power supply
- Terminal blocks
- Factory installed strut
- Custom options available - consult factory

Catalog Number Matrix

Part number example

CCBF12 F15 DS250 SP DCM

Combiner box, fiberglass NEMA 4X enclosure, 12 string, 15A fused, 250A integral disconnect switch, surge protection, DC current monitoring

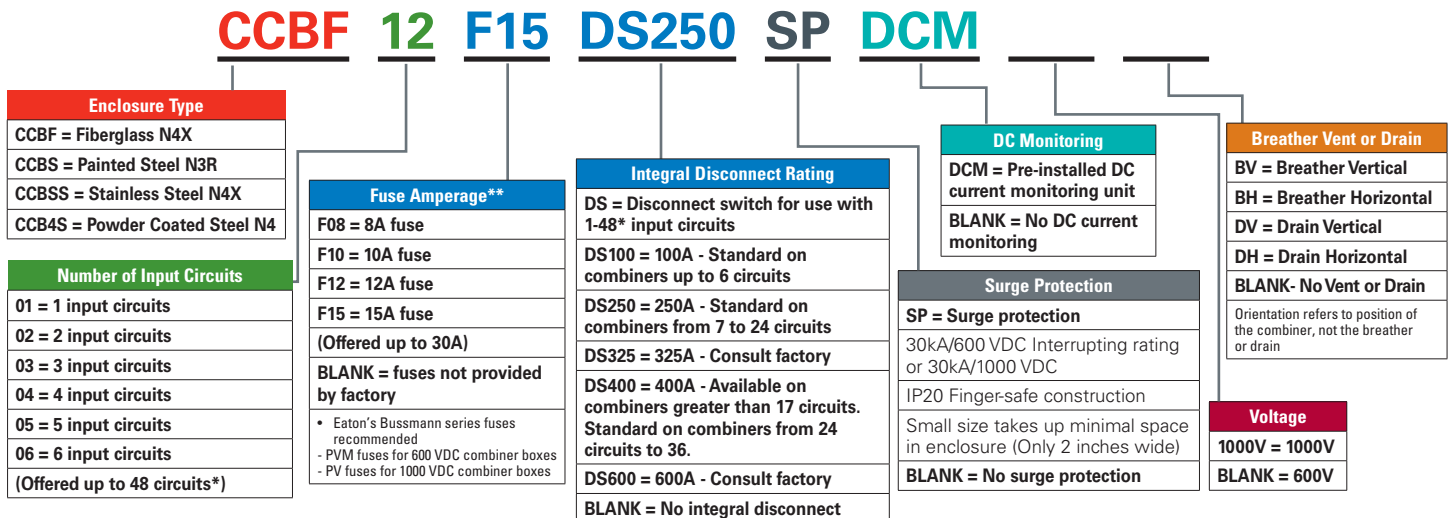

*Combiners with 37-48 input circuits are not third party certified, but are constructed to UL 1741 standards.

**Negative fused configurations available for positive grounded arrays. Replace F15 with NF15 in the catalog number.

1500 VDC Solar Combiner Boxes

1500 VDC Solar Combiner Boxes, available with or without Integral DC Disconnect Switches, are built to minimize system costs by reducing wiring, resulting in less labor. They are available with up to 36 input circuits and help save material costs, installation time and labor. ETL listed to UL1741 standards, providing peace of mind and plenty of wiring room for ease of installation.

Features:

- Rated up to 1500 VDC - continuous duty
- Optional integral disconnects available in 275A and 500A
- Touch-safe fuse holders
- Lexan shield covers all live components
- 90°C output terminals
- Configured for positive and negative grounded arrays*

Certifications and Compliances:

- cETLus 1741 Listed
- cETLus Listed to CSA Standard C22.2 No. 31
- NEMA 4X (fiberglass and stainless steel)
- NEMA 4 (powder coated steel)
- NEMA 3R (painted steel - for vertical mounting applications only)

Standard Materials and Finishes:

- NEMA 4X fiberglass (non-conductive, impact-resistant, UV-resistant, flame retardant) - natural
- NEMA 4X stainless steel - natural
- NEMA 4 steel - powder coated
- NEMA 3R steel (for vertical mounting applications only) - painted

Integral Disconnect Rating:

To determine the rating of the integral disconnect, simply multiply the number of input circuits by the max. current per string, and then round to the next (higher) disconnect size. In NO case can the maximum current exceed the amperage rating. Disconnect switches are rated for 100% continuous duty. Example: A 12-string combiner box with solar modules rated to 9.6A has a maximum current of 12A; 12A per string x 12 strings = 144A, which results in a 275A disconnect switch.



Options:

- Fuses (shipped uninstalled)
- Surge protection
- Solar cable whips (pre-assembled and installed)
- Compression output lugs (mechanical standard)
- Factory installed breather vent or drain
- Factory drilled entrance holes
- Factory installed conduit fittings/cable glands
- Dual output lugs
- Lockable enclosures
- Factory installed strut
- Custom options available - consult factory

Catalog Number Matrix

Part number example

CCBF12 F15 DS275 SP 1500V

Combiner box, fiberglass NEMA 4X enclosure, 12 string, 15A fused, 275A integral disconnect switch, surge protection, 1500V rating

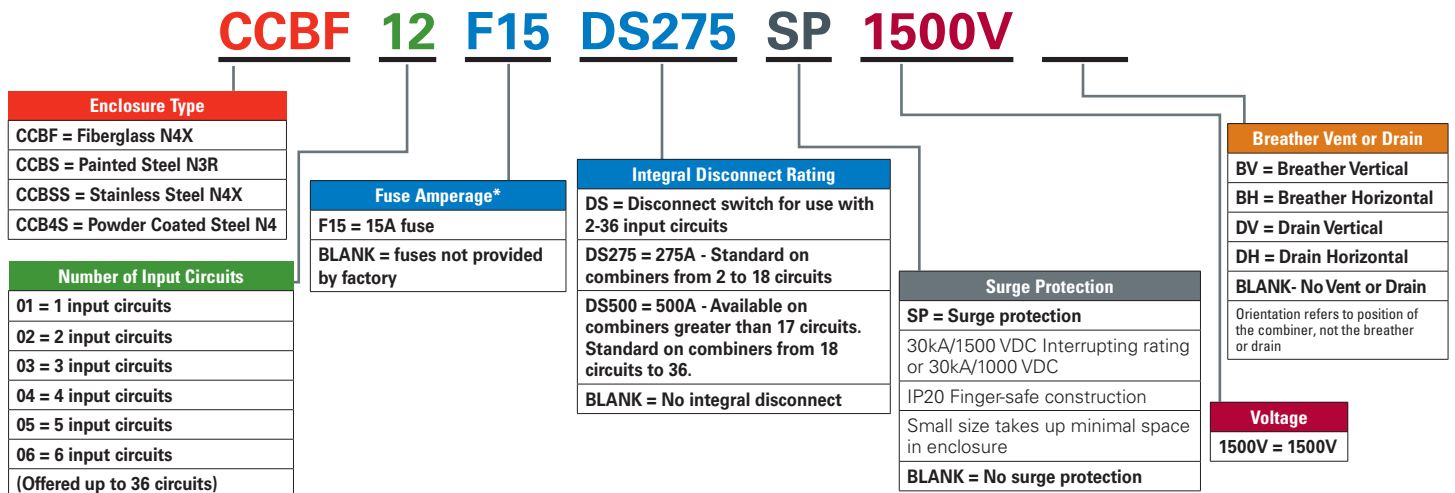

*Negative fused configurations available for positive grounded arrays. Replace F15 with NF15 in the catalog number.

High Amperage Solar Combiner Boxes

High Amperage Combiner Boxes are engineered, tested and third party certified for use in PV systems designed with T-junction cable harnesses to reduce installation labor, material costs and system maintenance.

Application:

High-Amperage Solar Combiner Boxes are designed and built to minimize costs in grid-tied PV system applications designed with T-junction cable harness wiring. T-connection harnesses allow for the combination of two strings in parallel prior to entry and termination in the combiner box. The use of these T-connection harnesses in conjunction with high amperage solar combiner boxes reduces cable, labor and overall installed PV system costs. The boxes are available in models with up to 20 input circuits and a 30A max. fuse size, with durable (NEMA 4X, 4 and 3R) enclosures and flexible custom options to suit customer applications. The robust design is engineered for greater heat dissipation and manufactured to perform in the harshest of environmental conditions. ETL listed to UL1741 standards, they provide peace of mind and plenty of wiring room for ease of installation.



Features:

- Isc rating 19.2A at 50°C
- Rated for 600 VDC or 1000 VDC - continuous duty
- Integral disconnects available in 100A, 250A, 320A, 400A and 600A
- Open type fuse holders with added spacing for improved heat dissipation and ease of wiring
- Lexan shield covers all live components
- 90°C output terminals
- Configured for positive and negative grounded arrays**

Certifications and Compliances:

- cETLus 1741 Listed
- cETLus Listed to CSA Standards C22.2 No. 31 & No. 107.1
- NEMA 4X (fiberglass and stainless steel)
- NEMA 4 (powder coated steel)
- NEMA 3R (painted steel - for vertical mounting applications only)

Standard Materials and Finishes:

- NEMA 4X fiberglass (non-conductive, impact-resistant, UV-resistant, flame retardant) - natural
- NEMA 4X stainless steel - natural
- NEMA 4 steel - powder coated
- NEMA 3R steel (for vertical mounting applications only) - painted

Options:

- Fuses (shipped uninstalled)
- Surge protection
- Solar cable whips (pre-assembled and installed) - see page 8
- Compression output lugs
- Factory installed breather vent
- Factory installed drain
- Factory drilled entrance holes
- Factory installed conduit fittings/cable glands
- Custom lugs available upon request
- Lockable enclosures
- Custom options available - consult factory
- Factory installed post-mount strut

Integral Disconnect Rating:

To determine the required rating of integral disconnect, simply multiply the number of input circuits by the panel max. short circuit current, and then multiply that figure by 125%. Round the result to the next (higher) disconnect size. Disconnect switches are rated for 100% continuous duty. In NO case can the maximum output current exceed the disconnect amperage rating. Example: In a T-junction application where two strings are combined prior to entry into the combiner box, a 16-string combiner box with max. short circuit current of 19.2A per string: $(2 \times 9.6A) \times 16 \text{ strings} \times 1.25 = 384A$, which equates to a 400A disconnect switch. See technical information for combiner box maximum Isc, current and fuse size calculations.

Catalog Number Matrix

Part number example

CCBF12 F30 DS400 SP

Combiner box, fiberglass NEMA 4X enclosure, 12 string, 30A fused, 400A integral disconnect switch, surge protection

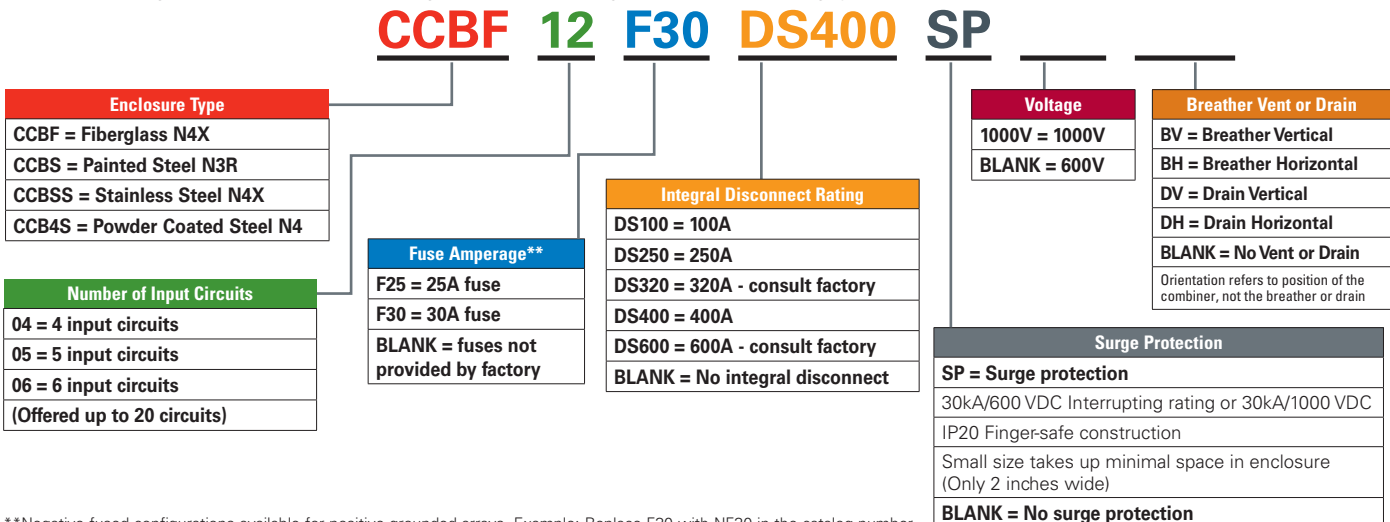

**Negative fused configurations available for positive grounded arrays. Example: Replace F30 with NF30 in the catalog number.

Solar Combiner Whips (For selection with Crouse-Hinds Series Solar Combiner Boxes)

Solar Cable Whips are engineered, tested, third party certified and assembled with Crouse-Hinds Series Solar Combiner Boxes* for use in utility and commercial PV systems to save on-site labor and lower installed costs.

Applications:

- For use in utility and commercial PV systems

Benefits:

- Manufactured and assembled in controlled conditions utilizing high efficiency equipment, reducing job site risk
- Eliminates on-site crimping, cutting, pulling cable through glands and termination in combiner boxes
- Manufactured with highest quality UV stabilized materials designed for long, dependable life in harsh and demanding environments

Features:

- Rated for use with 600 VDC or 1000 VDC combiner boxes (whips rated to meet or exceed combiner box voltage rating)
- Pre-configured by string count with selected solar combiner boxes
- 1' to 6' standard lengths (outside of combiner box)
- #10 AWG cable size standard on all configurations
- Includes positive and negative solar cord grips, cable and connectors
- Whips are labeled inside and outside combiner box with string number and polarity
- Whips are available in black, white, yellow and red for polarity designation
- 100% continuity tested to ensure dependable service
- IP67 or IP68 waterproof rated dependent on connector type
- Fully tested for continuity and hi-pot for dependable field performance
- Designed for exposed or concealed wet or dry locations
- UV-resistant
- Temperature range: -40°C to +90°C
- Custom configurations and string ID labeling available; consult factory.
- Whips are coiled, banded and protected during shipment

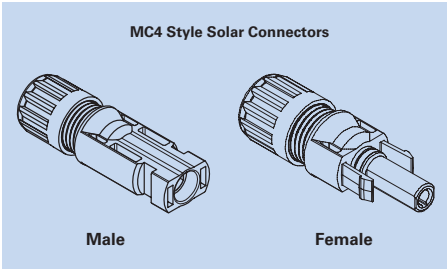

Certifications and Compliances:

- Combiner boxes with factory installed whips are cETLus Listed to UL1741
- Combiner boxes with factory installed whips are cETLus Listed to CSA Standards C22.2 No. 31 and No. 107.1
- Connectors UL certified to UL6703, TUV certified, IP67 or IP68 rated
- Cable UL certified to UL4703/UL854
- Flammability meets UL94 requirements

Standard Materials and Finishes:

- Cable - cross linked polyethylene wire (XLPE)

Catalog Number Matrix (suffix to be added to end of combiner box catalog number)

Part number example

3 USE2 BB MC4

3 foot, USE2 cable whip, black positive and black negative cable, MC4 connectors

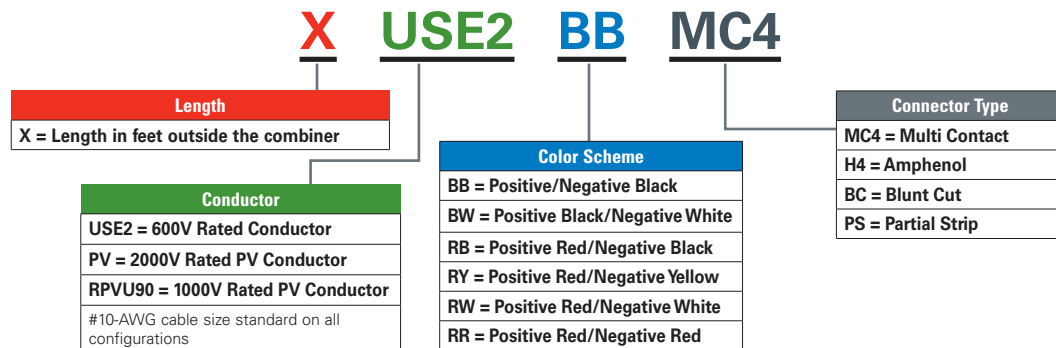

*For selection and shipment of whips independent of combiner boxes, please see pages 18-20.

Compact (SL Series) Solar Combiners

Compact Solar Combiner Boxes are designed and built to provide long, dependable service in a low profile space-saving design. Compact combiners are third party listed to UL1741 to provide long, dependable service and peace of mind. They are available from factory stock in either 4 or 6 circuits with or without fuses to meet tight job delivery requirements. Engineered, manufactured and certified NEMA 4X, they can be mounted either vertically or horizontally and are designed to perform in the harshest environmental conditions.

Applications:

- The ideal compact solution for commercial and residential rooftop installations with tight space and NEMA 4X requirements, offering maximum performance in a smaller physical footprint

Features:

- Available in either 4 or 6 input circuit models to match the most common customer requirements for a compact combiner
- Continuous duty rated at 600 VDC
- NEMA 4X fiberglass 8 x 8 x 6 enclosures with captive stainless steel screws and formed-in-place polyurethane seamless gasket provided as standard
- Third party certified to UL1741 and CSA Standard C22.2 No. 107.1
- Touch-safe fuse holders and power distribution blocks for safe operation
- 90°C output terminals
- Configured for positive and negative grounded arrays*
- Ground blocks included
- External mounting feet included for quick, easy installation
- Rated for continuous operation at 50°C
- 15A max. fuse size
- Eaton's Busmann series UL2579 fast-acting 600 VDC Midget fuses provided as standard with fused models

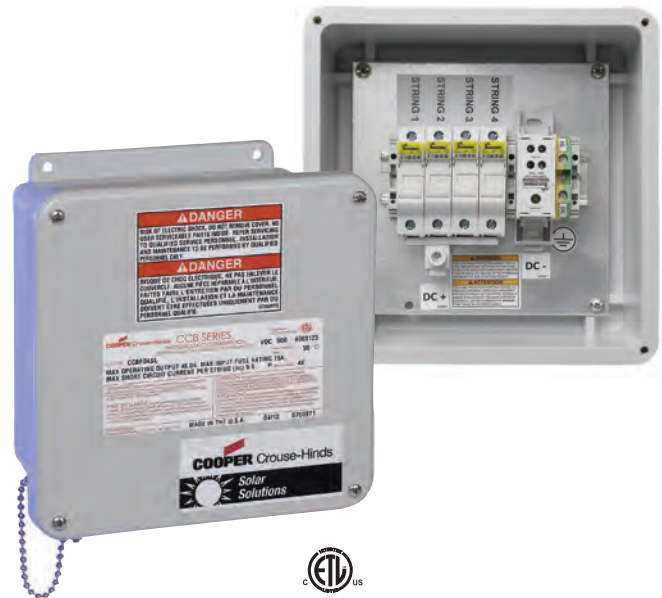

Certifications and Compliances:

- cETLus 1741 Listed
- CSA Standard C22.2 No. 107.1
- NEMA 4X

Standard Materials and Finishes:

Fiberglass Enclosure:

- Hot compression molded fiberglass-reinforced thermoset polyester
- Non-conductive, impact-resistant, UV-resistant, flame retardant
- Poured polyurethane seamless gasket provides watertight, dusttight environmental seal
- Stainless steel used on all external hardware

Technical Specifications:

- 600 VDC
- 15A max. fuse size (A)
- 9.6A max. PV module short circuit current
- 50°C ambient
- #14-#8 input conductors
- #2 AWG output conductors
- Dimensions (in.): 08 x 08 x 06
- NEMA 4X
- Suitable for vertical or horizontal mounting

Ordering Information:

Cat. #	Number of Strings	Max Current (A)	Description
CCBF04SL	4	48	4 String Compact Combiner, N4X Fiberglass
CCBF04SL F15	4	48	4 String Compact Combiner, N4X Fiberglass, 15A Fuse
CCBF06SL	6	72	6 String Compact Combiner, N4X Fiberglass
CCBF06SL F15	6	72	6 String Compact Combiner, N4X Fiberglass, 15A Fuse

*Negative fused configurations available for positive grounded arrays. Replace F15 with NF15 in the catalog number.

Solar Recombiners

In large PV systems, multiple combiner boxes are often necessary, and the outputs of these combiner boxes may need to be combined again (recombined) before reaching a central inverter. Eaton's Crouse-Hinds Series Recombiner Boxes allow for ease of installation, saving time, labor and most importantly, system costs. Solar recombiners range from 2 to 12 input circuits, with a durable non-metallic (NEMA 4X) or metallic (NEMA 4 and 3R) painted steel enclosure.

Features:

- Rated for 600 VDC or 1000 VDC - continuous duty
- 2-12 input circuits with configurations up to 1200A
- Factory installed fuses included
- Lexan shield covers all live components
- 90°C output terminals
- Configured for positive and negative grounded arrays
- Designed to ease installation of large cable inputs
- ETL Listed to UL1741 to provide peace of mind

Options:

- Surge protection
- Smart recombiners available (DC string monitoring)
- Factory drilled entrance holes
- Factory installed conduit fittings
- Bipolar construction
- Factory installed breather, drain and desiccant
- Integral power supply, flex I/O, terminal blocks
- Integral disconnects available in 100A, 250A, 400A and 600A - consult factory
- Multiple disconnect options available - consult factory
- Custom options available - consult factory

Standard Materials and Finishes:

- NEMA 4X fiberglass (non-conductive, impact-resistant, UV-resistant, flame retardant) - natural
- NEMA 4X stainless steel - natural
- NEMA 4 steel - powder coated
- NEMA 3R steel (for vertical mounting applications only) - painted



Certifications and Compliances:

- cETLus 1741 Listed
- cETLus Listed to CSA Standard C22.2 No. 31 & No. 107.1
- NEMA 4X (fiberglass and stainless steel)
- NEMA 4 (powder coated steel)
- NEMA 3R (painted steel - for vertical mounting applications only)

Catalog Number Matrix

Part number example

CRBF02 F100 SP 1000V

Recombiner box, fiberglass NEMA 4X enclosure, 2 circuits, 100A fused, surge protection, 1000VDC

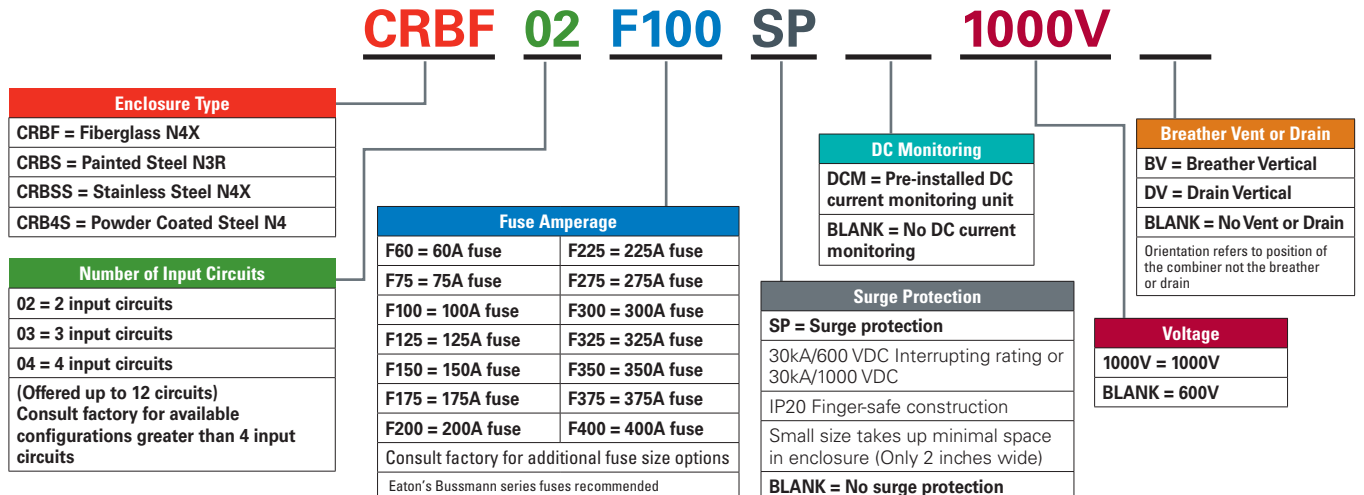

DC Safety Disconnect Boxes

DC Safety Disconnect Boxes are a universal solution for a disconnecting means before the inverter in commercial and utility PV systems. These disconnect enclosures house multiple UL Listed load break disconnect switches, reducing enclosure and labor costs. These disconnect boxes have a flexible design to accommodate a wide variety of PV applications, which greatly simplifies the installation.

Applications:

- Intended to be used to make or break electrical connections and disconnect any modules from downstream components
- For use with 600 VDC or 1000 VDC PV applications
- Meets NEC code requirements for a means of disconnection before the inverter

Features:

- Rated for 600 VDC or 1000 VDC
- 1-12 inputs
- Rated for up to 3,200A
- Rated for 100% continuous duty
- Available in 100A – 600A disconnect switch ratings
- Configured for positive and negative grounded arrays
- 90°C output terminals that can support both aluminum and copper wire
- Protective shield covers all live parts
- Comes equipped with a NEMA 4X external handle which allows for lockout/tagout capabilities
- ETL listed to UL1741 to provide peace of mind and plenty of wiring room for ease of installation
- Designed to ease installation of large cable inputs

Standard Materials and Finishes:

- NEMA 4X fiberglass (non-conductive, impact-resistant, UV-resistant, flame retardant) - natural
- NEMA 4X stainless steel - natural
- NEMA 4 steel - powder coated
- NEMA 3R steel (for vertical mounting applications only) - painted



Options/Special Configurations:

- Positive incoming, and positive and negative incoming circuit configurations available
- Pad-mount or free-standing custom enclosures
- Mounting brackets
- Wiring pedestal available to allow more wiring room
- Custom labeling
- Factory drilled holes
- Factory installed fittings, conduit and cable
- Factory installed breather vent or drain
- Custom options available - consult factory

Certifications and Compliances:

- cETLus 1741 Listed
- cETLus Listed to CSA Standard C22.2 No. 31 and No. 107.1
- Rated for up to 3,200A
- Disconnect switch is UL98B listed

Catalog Number Matrix

Part number example

CDBS04 4DS250 1000V

Painted Steel N3R DC Safety Disconnect Box with 4 input circuits, 4 disconnect switches, 250A integral disconnect, 1000VDC

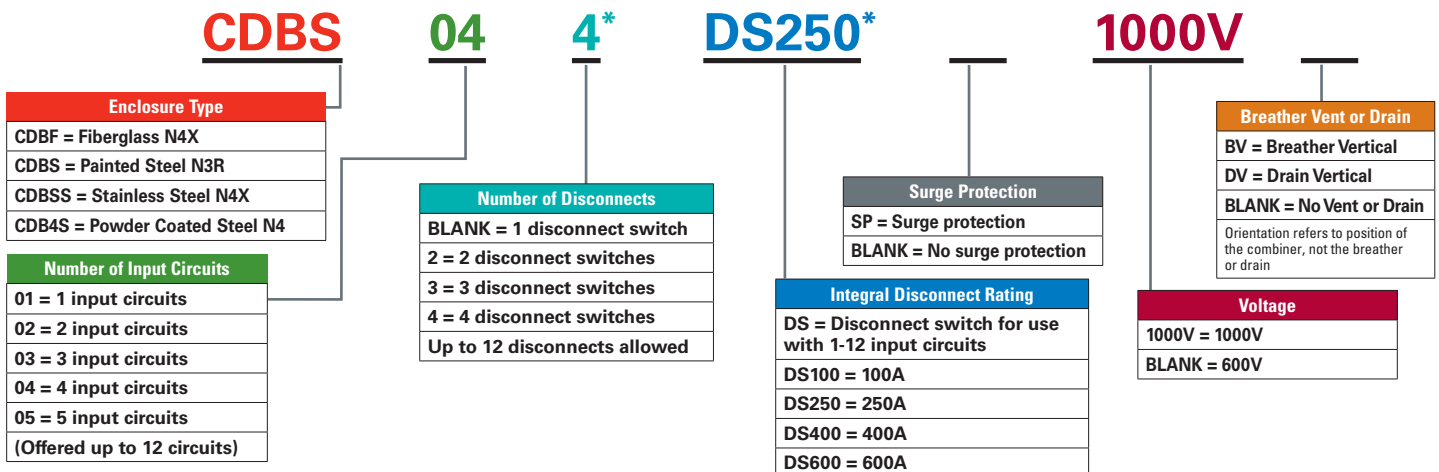

*For multiple disconnect sizes in the same enclosure, insert additional integral disconnect switch selection.

Solar Pass Through Boxes

Solar Pass Through Boxes (sometimes referred to as “transition boxes”) are used in residential applications to provide a low profile, cost-effective way to group input wires/circuits from several arrays and/or solar panels and transition from solar (PV) cable to regular building wire. The Pass Through Box was designed for PV applications where overcurrent protection is not necessary due to the low power rating of the PV string.

Features:

- Rated 600 VDC or 1000 VDC continuous duty
- Constructed in accordance with UL1741 standards and provides spacious wiring room for quick, easy wire termination
- Factory installed multi-hole solar cord grip provides dependable, secure wire termination to enclosure and saves field installation – eliminating the need for enclosure drilling, saving time and labor
- Fiberglass enclosures with captive stainless steel screws and formed-in-place polyurethane seamless gasket provided as standard
- Available in N3R sheet steel enclosures – consult factory
- Lightweight design offers easy mounting capabilities; optional mounting feet are available for increased customer flexibility
- Rated for continuous operation at 60°C ambient



Standard Materials and Finishes:

Fiberglass Enclosure:

- Hot compression molded fiberglass-reinforced thermoset polyester
- Non-conductive, impact-resistant, UV-resistant, flame retardant
- Poured polyurethane seamless gasket provides watertight, dusttight environmental seal
- Stainless steel used on all external hardware

Certifications and Compliances:

- cETLus 1741 Listed
- cETLus Listed to CSA Standard C22.2 No. 31 & No. 107.1
- NEMA 4X

Ordering Information:

Note: For 1000 VDC Pass Through Boxes, add 1000V to the catalog number.

Cat. #	Description	Cat. #	Description
CPBF03	3 Circuit Pass Through Box	CPBF20	20 Circuit Pass Through Box
CPBF04	4 Circuit Pass Through Box	CPBF21	21 Circuit Pass Through Box
CPBF05	5 Circuit Pass Through Box	CPBF22	22 Circuit Pass Through Box
CPBF06	6 Circuit Pass Through Box	CPBF23	23 Circuit Pass Through Box
CPBF07	7 Circuit Pass Through Box	CPBF24	24 Circuit Pass Through Box
CPBF08	8 Circuit Pass Through Box	CPBF25	25 Circuit Pass Through Box
CPBF09	9 Circuit Pass Through Box	CPBF26	26 Circuit Pass Through Box
CPBF10	10 Circuit Pass Through Box	CPBF27	27 Circuit Pass Through Box
CPBF11	11 Circuit Pass Through Box	CPBF28	28 Circuit Pass Through Box
CPBF12	12 Circuit Pass Through Box	CPBF29	29 Circuit Pass Through Box
CPBF13	13 Circuit Pass Through Box	CPBF30	30 Circuit Pass Through Box
CPBF14	14 Circuit Pass Through Box	CPBF31	31 Circuit Pass Through Box
CPBF15	15 Circuit Pass Through Box	CPBF32	32 Circuit Pass Through Box
CPBF16	16 Circuit Pass Through Box	CPBF33	33 Circuit Pass Through Box
CPBF17	17 Circuit Pass Through Box	CPBF34	34 Circuit Pass Through Box
CPBF18	18 Circuit Pass Through Box	CPBF35	35 Circuit Pass Through Box
CPBF19	19 Circuit Pass Through Box	CPBF36	36 Circuit Pass Through Box



Solar Accessories

Eaton's Crouse-Hinds Division provides solar cable management options for all your bundling and harnessing of PV solar wires.

Solar Lay-in Grounding Lugs

Applications:

Solar Lay-in Grounding Lugs are the ideal choice for the quick installation of one continuous grounding conductor or as a jumper to multiple locations. Just unscrew the set screw, lay in the cable and re-tighten, making it easy to retrofit or repair.

Features:

- Tin plated copper for additional corrosion resistance
- For use with #4-14 cable
- Stainless steel slotted screw
- Suitable for direct burial and outdoor use
- Ideal for continuous grounding of solar PV panels
- Suitable for use with copper conductors only, solid or stranded

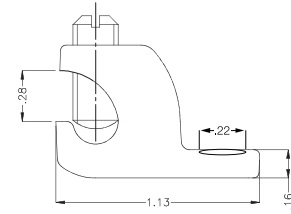

Certifications and Compliances:

- cULus Listed
- UL File No. E-6225



Standard Materials and Finishes:

- Body - copper, tin plated
- Screw - stainless steel, natural

Ordering Information:

Cat. #	Description	Cable	Unit Qty	Wt. Lbs. Per 100
SLL414T	Solar Grounding Lug	#4-14	100	5

Solar Accessories - Cable Clips

Applications:

Solar Cable Clips provide cable management options for bundling and harnessing PV solar wire anywhere between the panels to the inverter.



Certifications and Compliances:

- UL Listed
- cUL Listed
- UL File No. E-364841

Standard Materials and Finishes:

- Steel clip - corrosion-resistant 304 stainless steel, natural
- 12 position clip - PPE and PS flame retardant "Noryl" material with a 301 stainless steel mounting clip

Features - Steel Clip:

- Manufactured out of corrosion-resistant 304 stainless steel
- Double compression design which can accommodate one 12 gauge USE-2 wire or two 10 gauge PV-1000 wires
- Smooth clip edges which prevent damage to cable insulation
- Screwdriver designed slot which allows for easy removal or movement of the clip when necessary
- Dual cable clip to hold .413" to .472" in the top slot and .300" in the bottom slot
- 90° clip designed to mount at a 90° angle to the original clip (SCLP1)

Features - 12 Position Clip:

- Holds up to 12 cables with wire diameters ranging from .20" to .28"
- Internal locking tabs secure the cables in place to prevent any movement
- Maximum temperature rating of 203°F
- Flush mount design easily attaches to any flat surface with four mounting screws

Ordering Information:

Cat. #	Description	Panel Thickness Clamping Range		Wire Dia. Range Max. (2) Wires	Height in.	Unit Qty.	Wt. Lbs. Per 100
		Minimum in.	Maximum in.				
SCLP1	Solar PV Cable Clip	0.06	0.13	.20" (5.0 mm) - .30" (7.6 mm) each cable	0.39	100	1
SCLP190	Solar PV Cable Clip, 90° Degree	0.55	0.13	.20" (5.0 mm) - .30" (7.6 mm) each cable	0.39	100	1
SCLP2	Solar PV Dual Cable Clip	0.06	0.25	.30" (7.6 mm) - .47" (11.9 mm) each cable	0.45	100	2
SCLP12*	Solar PV Dual Cable Clip, 12 Position	0.06	0.25	.20" (5.0 mm) - .28" (7.2 mm) each cable	0.98	100	1
SCLP12F*	Solar PV Dual Cable Clip, 12 Position, Flush Mount	N/A	N/A	.20" (5.0 mm) - .28" (7.2 mm) each cable	1.00	100	1

*UL and cUL Listed

Solar Accessories

Non-metallic Cord Grips

Applications:

Solar Cord Grips are used in both commercial and residential grid-tied PV solar applications and are designed to accommodate the entry of multiple PV wires coming into a combiner or pass through box. The Solar Cord Grips provide mechanical strain relief as well as a liquidtight seal around the solar panel wires.

Features:

- Multi-hole cord grip to allow for entry of multiple PV wires
- Solar cord grips offer customer flexibility by allowing the termination from 1 to 31 PV wires in a single connector
- Skinned over glands provide a durable, liquidtight seal around the wires
- No disassembly required for installation
- Wide range of cable acceptance sizes for customer flexibility
- Steel locknuts included
- Temperature rating: -22°F (-30°C) to 212°F (100°C) to meet the most demanding environmental conditions



Certifications and Compliances:

- UL/cUL recognized
- UL File No. E-23223
- IP68
- Flammability rating: 94-V2

Standard Materials:

- 6/6 nylon with TPE/Buna N sealing glands, natural

Ordering Information:

Cat. #	Trade Size	No. of Holes	Hole Cable Diam.	Wire Type	Size
NCGS25	3/4"	5 Holes	5mm	USE-2	12 AWG, 10 AWG
NCGS237*	3/4"	3 Holes	7mm	1000V PV Cable	12 AWG, 10 AWG
NCGS39	1"	9 Holes	5mm	USE-2	12 AWG, 10 AWG
NCGS357*	1"	5 Holes	7mm	1000V PV Cable	12 AWG, 10 AWG
NCGS413	1-1/4"	13 Holes	5mm	USE-2	12 AWG, 10 AWG
NCGS497*	1-1/4"	9 Holes	7mm	1000V PV Cable	12 AWG, 10 AWG
NCGS478*	1-1/4"	7 Holes	8mm	1000V PV Cable	12 AWG, 10 AWG, 8 AWG
NCGS521	1-1/2"	21 Holes	5mm	USE-2	12 AWG, 10 AWG
NCGS5117	1-1/2"	11 Holes	7mm	1000V PV Cable	12 AWG, 10 AWG
NCGS598	1-1/2"	9 Holes	8mm	1000V PV Cable	12 AWG, 10 AWG, 8 AWG
NCGS631	2"	31 Holes	5mm	USE-2	12 AWG, 10 AWG
NCGS6197*	2"	19 Holes	7mm	1000V PV Cable	12 AWG, 10 AWG
NCGS6128*	2"	12 Holes	8mm	1000V PV Cable	12 AWG, 10 AWG, 8 AWG

*UL Listed.

Solar Cable Ties

Applications:

Solar Cable Ties provide cable management options for bundling and harnessing PV solar wire anywhere between the panels to the inverter.

Features:

- Equipped with a UV protected vinyl jacket which prevents damage to installation cable insulation and ensures durability
- Tin plated with a copper crimp sleeve which allows for easy field installation
- Constructed from commercial aircraft grade stainless wire for long, dependable service



Standard Materials:

- UV-resistant vinyl jacketing, tin plated copper crimp sleeve, commercial aircraft grade stainless wire

Ordering Information:

Cat. #	Description	Part Specification		Part Dimensions		Unit Qty	Wt. Lbs. Per 100	
		Min. Tensile Strength	Max. Bundle Dia.	Length	Cable Dia.			
		lbs.	N	in.	in.	in.		
SCBLTIE8	Solar Cable Tie 8"	100	440	2.30	8	0.06	100	1
SCBLTIE10	Solar Cable Tie 10"	100	440	2.92	10	0.06	100	1
SCBLTIE12	Solar Cable Tie 12"	100	440	3.88	12	0.06	100	1
SCBLTIE14	Solar Cable Tie 14"	100	440	4.20	14	0.06	100	1
SCBLTIE20	Solar Cable Tie 20"	100	440	6.30	20	0.06	100	1

Technical Information

Solar Combiner CCB Series Technical Information

Standard Design:			Tech Spec					Mech Spec**				
1.0 CCB Series	Description	Voltage	Max. Ambient	Max. Fuse Size	Max. Current for Greatest Number of Strings	Max. PV Module Short Circuit Current	Input Conductors (Cu. Only)		Output Conductors (Cu/Al)		Fiberglass Dimensions (in.)	NEMA Rating
		(VDC)	(°C)	(A)	(A)	(A)	Wire Gauge	Torque (in-lbs)	Wire Gauge	Torque (in-lbs)	(in)	Type
1.1	CCB_06 SL 6 String Small Line Combiner Box (02-06 Strings)	600/1000/1500	50	15	72	9.6	#14 - #8	25	#14 - #2	50	08x08x05	4X/4/3R
1.2	CCB_06 6 String Combiner Box (02-06 Strings)	600/1000/1500	50	15	72	9.6	#14 - #8	25	250 MCM or 350 MCM	325	12x10x05	4X/4/3R
1.3	CCB_12 12 String Combiner Box (07-12 Strings)	600/1000/1500	50	15	144	9.6	#14 - #8	25	250 MCM or 350 MCM	325	16x14x06	4X/4/3R
1.4	CCB_18 18 String Combiner Box (13-18 Strings)	600/1000/1500	50	15	216	9.6	#14 - #8	25	350 MCM	325	18x16x08	4X/4/3R
1.5	CCB_24 24 String Combiner Box (19-24 Strings)	600/1000/1500	50	15	288	9.6	#14 - #8	25	500 MCM	375	20x16x08	4X/4/3R
1.6	CCB_36 36 String Combiner Box (25-36 Strings)	600/1000/1500	50	15	433	9.6	#14 - #8	25	500 MCM	375	24x20x08	4X/4/3R
1.7	CCB_06 DS 6 String Combiner Box w/ Integral Disconnect Switch (02-06 Strings)	600/1000/1500	50	15	72	9.6	#14 - #8	25	250 MCM or 350 MCM	325	18x16x08	4X/4/3R
1.8	CCB_12 DS 12 String Combiner Box w/ Integral Disconnect Switch (07-12 Strings)	600/1000/1500	50	15	144	9.6	#14 - #8	25	250 MCM or 350 MCM	325	18x16x08	4X/4/3R
1.9	CCB_18 DS 18 String Combiner Box w/ Integral Disconnect Switch (13-18 Strings)	600/1000/1500	50	15	216	9.6	#14 - #8	25	350 MCM	325	20x16x08	4X/4/3R
1.10	CCB_24 DS 24 String Combiner Box w/ Integral Disconnect Switch (19-24 Strings)	600/1000/1500	50	15	288	9.6	#14 - #8	25	500 MCM	375	24x20x08	4X/4/3R
1.11	CCB_36 DS 36 String Combiner Box w/ Integral Disconnect Switch (25-36 Strings)	600/1000/1500	50	15	433	9.6	#14 - #8	25	500 MCM	375	36x30x10	4X/4/3R

Solar Combiner CCB High Amperage Series Technical Information

Standard Design:			Tech Spec					Mech Spec**				
1.0 CCB High Amperage Series	Description	Voltage	Max. Ambient	Max. Fuse Size	Max. Current for Greatest Number of Strings	Max. PV Module Short Circuit Current	Input Conductors (Cu. Only)		Output Conductors (Cu/Al)		Fiberglass Dimensions (in.)	NEMA Rating
		(VDC)	(°C)	(A)	(A)	(A)	Wire Gauge	Torque (in-lbs)	Wire Gauge	Torque (in-lbs)	(in)	Type
2.1	CCB_06 6 String Combiner Box (02-06 Strings)	600/1000	50	30	144	19.2	#14 - #8	35	350 MCM	325	20x16x08	4X/4/3R
2.2	CCB_12 12 String Combiner Box (07-12 Strings)	600/1000	50	30	288	19.2	#14 - #8	35	500 MCM	375	24x20x10	4X/4/3R
2.3	CCB_18 18 String Combiner Box (13-18 Strings)	600/1000	50	30	433	19.2	#14 - #8	35	500 MCM	375	24x24x10	4X/4/3R
2.4	CCB_24 24 String Combiner Box (19-24 Strings)	600/1000	50	30	577	19.2	#14 - #8	35	800 MCM	500	24x24x10	4X/4/3R
2.5	CCB_06 DS 6 String Combiner Box w/ Integral Disconnect Switch (02-06 Strings)	600/1000	50	30	144	19.2	#14 - #8	35	350 MCM	325	24x20x10	4X/4/3R
2.6	CCB_12 DS 12 String Combiner Box w/ Integral Disconnect Switch (07-12 Strings)	600/1000	50	30	288	19.2	#14 - #8	35	500 MCM	375	24x24x10	4X/4/3R
2.7	CCB_18 DS 18 String Combiner Box w/ Integral Disconnect Switch (13-18 Strings)	600/1000	50	30	433	19.2	#14 - #8	35	500 MCM	375	30x24x10	4X/4/3R
2.8	CCB_24 DS 24 String Combiner Box w/ Integral Disconnect Switch (19-24 Strings)	600/1000	50	30	576	19.2	#14 - #8	35	800 MCM	500	36x30x12	4X/4/3R

Solar CPB Pass Through Box Series Technical Information

Standard Design:			Tech Spec				Mech Spec**				
3.0 CPB Series	Description	Voltage	Max. Ambient	Max. Current	Max. PV Module Short Circuit Current	Input Conductors (Cu. Only)		Output Conductors (Cu. Only)		Dimensions	NEMA Rating
		(VDC)	(°C)	(A)	(A)	Wire Gauge	Torque (in-lbs)	Wire Gauge	Torque (in-lbs)	(in.)	Type
3.1	CPBF04 4 String Pass Through Box (01-04 Strings, 02-08 Terminals Total)	600/1000	60	(4) 15	9.6	#14 - #8	20	#14 - #8	20	06x06x04	4X/4/3R
3.2	CPBF08 8 String Pass Through Box (05-08 Strings, 10-16 Terminals Total)	600/1000	60	(8) 15	9.6	#14 - #8	20	#14 - #8	20	10x08x04	4X/4/3R
3.3	CPBF12 12 String Pass Through Box (09-12 Strings, 18-24 Terminals Total)	600/1000	60	(12) 15	9.6	#14 - #8	20	#14 - #8	20	14x12x06	4X/4/3R
3.4	CPBF16 16 String Pass Through Box (13-16 Strings, 26-32 Terminals Total)	600/1000	60	(16) 15	9.6	#14 - #8	20	#14 - #8	20	14x12x06	4X/4/3R

* For fiberglass only, consult factory for additional information.

• Consult factory for special output conductor requirements.

Technical Information

Solar Recombiner CRB Box Series Technical Information

Standard Design:			Tech Spec					Mech Spec**				
4.0 CRB Series	Description	Voltage	Max. Ambient	Max. Current	Max. Fuse Size	Max. PV Module Short Circuit Current	Input Conductors (Cu. Only)		Output Conductors (Cu. Only)		Fiberglass Dimensions (in.)	NEMA Rating
		(VDC)	(°C)	(A)	(A)	(A)	Wire Gauge	Torque (in-lbs)	Wire Gauge	Torque (in-lbs)	(in)	Type
4.0	CRB_03 3 Array Recombiner Box (01-03 Strings)	600/1000	50	1200	400	256.4	#4-500 MCM	450	#2-(2)600 MCM	150-450	Varies	4X/4/3R
4.1	CRB_06 6 Array Recombiner Box (01-06 Strings)	600/1000	50	1200	200	128.2	#6-250 MCM	275-375	#2-(2)600 MCM	150-450	Varies	4X/4/3R
4.2	CRB_12 12 Array Recombiner Box (01-12 Strings)	600/1000	50	1200	100	64.1	1/0-8	100	#2-(2)600 MCM	150-450	Varies	4X/4/3R
4.3	CRB_03 DS 3 Array Recombiner Box w/ Integral Disconnect Switch (01-03 Strings)	600/1000	50	1200	400	256.4	#4-500 MCM	450	#2-(2)600 MCM	150-450	Varies	4X/4/3R
4.4	CRB_06 DS 6 Array Recombiner Box w/ Integral Disconnect Switch (01-06 Strings)	600/1000	50	1200	200	128.2	#6-250 MCM	275-375	#2-(2)600 MCM	150-450	Varies	4X/4/3R
4.5	CRB_12 DS 12 Array Recombiner Box w/ Integral Disconnect Switch (01-12 Strings)	600/1000	50	1200	100	64.1	1/0-8	100	#2-(2)600 MCM	150-450	Varies	4X/4/3R

Solar Disconnect CDB Box Series Technical Information

Standard Design:			Tech Spec					Mech Spec**				
5.0 CDB Series	Description	Voltage	Max. Ambient	Max. Current	Max. Fuse Size	Max. PV Module Short Circuit Current	Input Conductors (Cu. Only)		Output Conductors (Cu. Only)		Fiberglass Dimensions (in.)	NEMA Rating
		(VDC)	(°C)	(A)	(A)	(A)	Wire Gauge	Torque (in-lbs)	Wire Gauge	Torque (in-lbs)	(in)	Type
5.0	CDB DS100 100A Disconnect Box (01-12 strings)	600/1000	50	(12) 100	N/A	N/A	#6 - 350 MCM	110 - 325	#6 - 350 MCM	110 - 325	Varies	4X/4/3R
5.1	CDB DS250 250A Disconnect Box (01-12 strings)	600/1000	50	(12) 250	N/A	N/A	#6 - 350 MCM	110 - 325	#6 - 350 MCM	110 - 325	Varies	4X/4/3R
5.2	CDB DS400 400A Disconnect Box (01-12 strings)	600/1000	50	(12) 400	N/A	N/A	#2 - 1000 MCM	150 - 500	#2 - 1000 MCM	150 - 500	Varies	4X/4/3R
5.3	CDB DS600 600A Disconnect Box (01-12 strings)	600/1000	50	(12) 600	N/A	N/A	#2 - 1000 MCM	150 - 500	#2 - 1000 MCM	150 - 500	Varies	4X/4/3R

Overcurrent Protection - PV Fuse-Links

Current Rating	Energy Integrals (A2s)		Power Loss (Watts)	
	Pre-arcing	Total at 1000V	In.	In.
8A	3	32	0.5	2.0
10A	7	50	0.6	2.1
12A	10	100	1.3	2.6
15A	20	200	1.8	3.0

Solar Combiner Fiberglass Enclosure Dimensional Information

Enclosure Cat. #	Enclosure Size	Overall Dimensions Inches (H x W x D)	Inside Dimensions Inches (H x W x D)	Mounting Dimensions Inches (H x W)	Approximate Weight (lbs.)
FJHP161406	16 x 14 x 06	17.53 x 15.46 x 6.23	15.63 x 13.60 x 5.94	16.75 x 12.00	12
FJHP201608	20 x 16 x 08	22.00 x 17.68 x 8.83	19.72 x 15.72 x 8.45	21.25 x 10.00	20
FJHP202010	20 x 20 x 10	23.50 x 22.12 x 11.70	19.88 x 19.88 x 11.33	21.88 x 18.30	30
FJHP242010	24 x 20 x 10	27.50 x 22.12 x 11.70	23.88 x 19.88 x 11.33	25.88 x 18.30	36
FJHP242410	24 x 24 x 10	27.50 x 26.12 x 11.70	23.88 x 23.88 x 11.33	25.88 x 22.00	42
F4WMSHL302407	30 x 24 x 07	33.41 x 26.32 x 8.81	30.46 x 25.47 x 7.12	32.25 x 18.50	45
F4WMSHL363008	36 x 30 x 08	39.31 x 32.50 x 10.05	36.31 x 31.69 x 9.36	38.13 x 23.88	58

* For fiberglass only, consult factory for additional information.

• Consult factory for special output conductor requirements.

Solar Configurator

The Crouse-Hinds Solar Combiner Configurator is the fastest way to configure and accurately select Eaton's Crouse-Hinds Series Solar Combiner Boxes with custom options! This easy-to-use configurator allows for simple attribute selection and generates catalog numbers, specification documents, and detailed engineering drawings to greatly simplify the project engineering specification process.

Access the configurator through Eaton's Crouse-Hinds Division website at www.crouse-hinds.com. Simply select Resources from the menu bar, product configuration from the drop-down menu, and click on the Solar Combiner Boxes icon as shown at right:



The configurator interface allows for quick and easy selection based on customer specification. With just a few clicks, selections can be made to generate a configuration to meet project requirements. After selections are saved, desired PDF drawings and specification sheets can be downloaded. Specs can be easily emailed directly from the configurator using the link at the top of the selection tool.

Selections Include:

- Combiner Boxes, Compact Combiner Boxes, Pass Through Boxes, and High Amperage Combiner Boxes
- Enclosures From NEMA 3R, 4, and 4X steel and fiberglass options available
- Integral disconnect switches
- Custom lugs
- Polarity and fuse options
- Custom options including surge protection, DC monitoring, breather vents, fittings, and more!
- Factory installed whips or bulkhead connectors

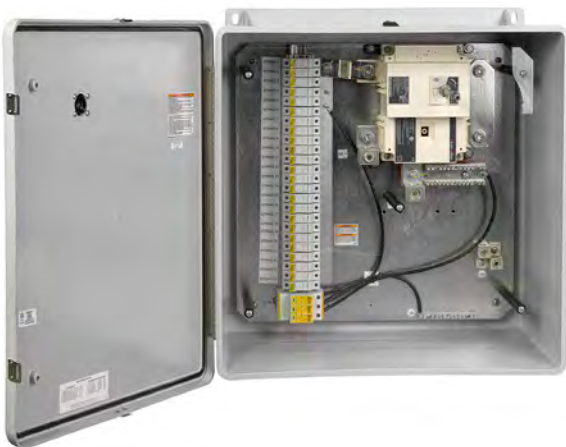

Selection Tool

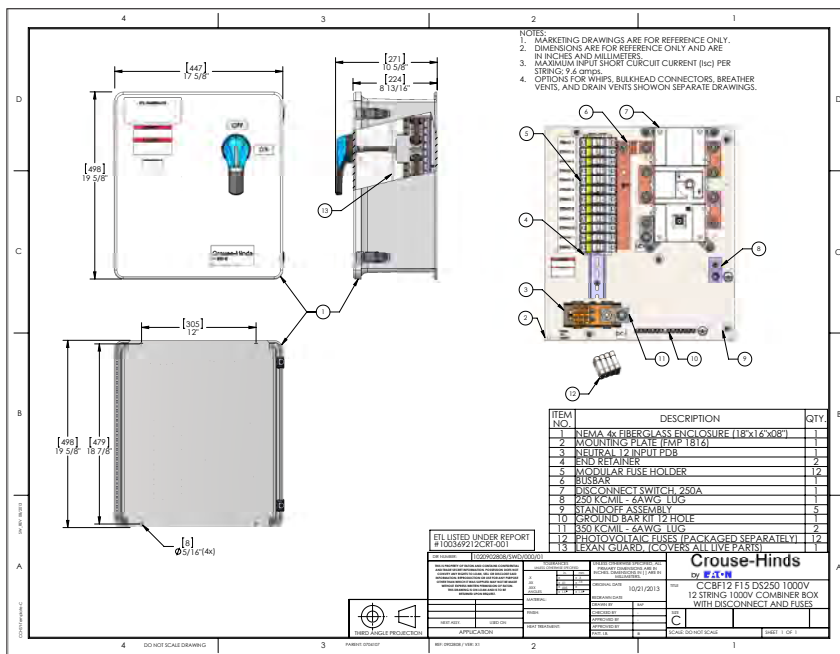

PDF Sales Drawing

Solar Combiner Scope of Supply Document		
CCBF12-F15-DS250-1000V	Series	Solar Combiner Box
	Enclosure Type	Fiberglass N4X
	Input Circuits	12 Input Circuits
	Voltage	1000 Volts
	Disconnect	Integral Disconnect Switch
	Disconnect Amperage	250A (Standard 7-24 Cir
	Output Lug Type	Mechanical Output Lugs
	Lug Size	350 Kcmil
	Fusing Included?	Include Fuses
	Polarity	F: (+) Fused Only
	Fusing Amperage	15 Amp Fuse
	Surge Protection	No
	DC Monitoring	No
	Breather	None
	Drain	None
	Cord Grips	No
	Myers Hub	No
	Pre-Drilled Enclosure Holes	No
	Pre-Terminated Solar Cable Whip	No
	Whip Length	N/A
	Whip Color	N/A
	Whip Connectors	N/A
	Whip Type	N/A
	Bulkhead Connector Type	N/A
	Bulkhead Connector Location	N/A
	Certifications	
		NEMA 4X
		Certified to CSA Standard C22.2 No. 31 and No. 107.1
		Certified to the UL 1741 Standard

Solar Combiner Specification Document

Sunconnector™ Solar Assemblies & Harnesses

Eaton's Crouse-Hinds Division has a long legacy of providing high reliability connectivity solutions in extremely harsh environments. Sunconnector™ solar products were developed to deliver outstanding value and reliability that we are known for in the solar industry.

- Manufactured in controlled conditions utilizing high efficiency equipment, reducing job site risk and potential warranty claims
- Manufactured with UV stabilized materials designed specifically to withstand harsh environmental exposure and abuse
- Custom manufactured assemblies reduce costs and make solar systems easier to install by eliminate on-site crimping, cutting and testing
- Whip and jumper assemblies are available in a variety of cable options, configurations and styles
- Harness assemblies are available in customized configurations to meet specific application requirements

SUNNECTOR™ Whip & Jumper

Pre-made to the highest standards, our Whip and Jumper Assemblies save you time and money

Whip and Jumper Assemblies speed solar panel installation and are constructed to deliver long-term reliability that will decrease call-backs and warranty service.

Assembly Applications:

- Combiner Boxes
- Modules
- Junction Boxes
- Traffic Signals & Signage
- Solar Kits
- Weather Transmitters
- Portable Power Systems

For use in:

- Rural Installations
- Residential
- Commercial



SUNNECTOR™ Parallel Circuit Array & Home Run Harness

Delivering convenience and quality in harnesses custom manufactured to your specifications

Our Sunconnector™ custom configured Harness Assemblies are constructed using only the highest quality wire, components and manufacturing processes for durability and longevity.

Assembly Applications:

- Inverters
- Sub-combiners
- Pull Through Boxes

For use in:

- Industrial
- Utility

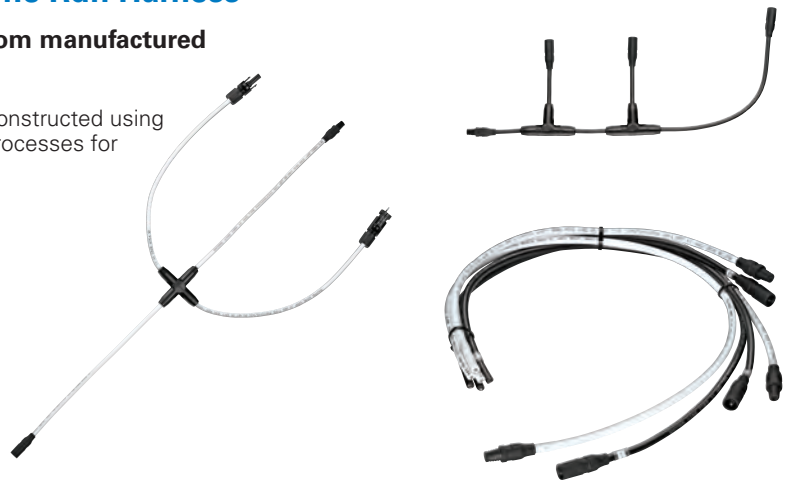

Sunnector™ Whip & Jumper Assemblies

Reduce installation time with pre-fabricated assemblies

Sunnector™ Assemblies are the preferred choice for smart installers and contractors looking to reduce the overall installed cost by 10% to 35%.*

SUPERIOR COMPONENTS MEANS HIGH QUALITY PERFORMANCE

Specially constructed to last years in the field and reduce overall installation times. Pre-marked assembly allows easy site layout.

Applications:

- Sunnector™ pre-fabricated jumpers and whips save time and money by providing various configurations that allow quick connections for a wide variety of solar applications.
- Both whips and jumpers are manufactured under controlled conditions utilizing the highest quality materials. They are designed to work with rigid & flexible thin-film, monocrystalline and multicrystalline PV modules.
- Whips are ideal for OEM applications, including combiner boxes, mini-inverters, modules and adapters. They are also ideal for solar powered safety, hazard or signaling device assemblies.
- In commercial and residential rooftop installations, the use of jumpers reduces the amount of on-site assembly and by eliminates crimping, cutting and testing.
- Jumpers are also optimal for off-grid self-contained solar power systems frequently found in rural or highly inaccessible locations.
- All whips and jumpers are 100% continuity tested to ensure dependable service and are available in many standard lengths.

Solar Whip Assemblies

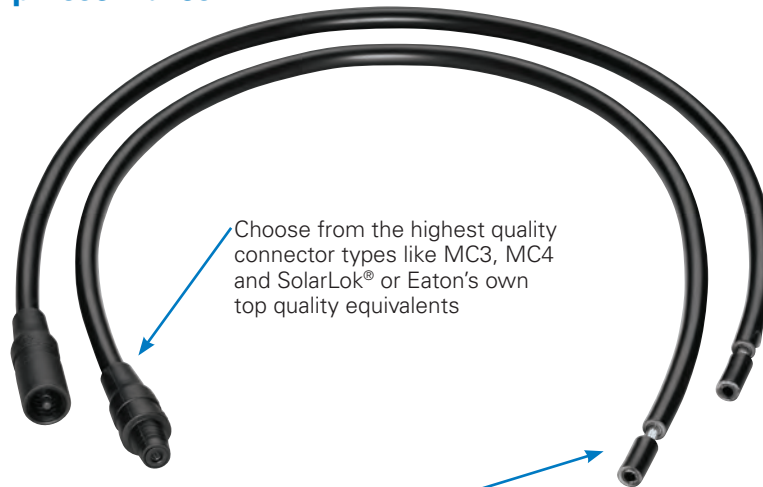

Choose from the highest quality connector types like MC3, MC4 and SolarLok® or Eaton's own top quality equivalents

Choose from different wire sizes capable of delivering 20A, 25A or 35A

Ends provided with your choice of hardware, including: ring terminals, fork terminals, fast-ons or as wire only, blunt cut or partially stripped

All whips and jumpers are 100% tested to ensure performance in the field

Solar Jumper Assembly



Eaton's Crouse-Hinds Division maintains excellent production standards including those meeting IPC-620A

Choose from a variety of standard wire types, including: USE-2, RHW-2, PV 1KV/2KV, double insulated or halogen free

Jumper configuration options include male to male, male to female, female to female and interseries connectivity

*Based on labor and material savings versus traditional wiring.
SolarLok is a registered trademark of Tyco Electronics.

Sunnector™ Whip & Jumper Assemblies

600V, 1000V and 2000V DC
 20A, 25A or 35A
 IP67 or IP68

Male & Female Assemblies

Features:

- Compatible with rigid and flexible thin-film, monocrystalline and multicrystalline PV modules
- IP67 or IP68 waterproof rated dependent on connector type
- UV- and ozone-resistant
- Fully tested for continuity and hi-pot for dependable field performance

- Pre-built assemblies are designed specifically for grid-tied, off-grid and OEM applications
- Delivered pre-assembled, facilitating quicker installation
- Optional ID labeling available to communicate point-to-point connections in the field

Certifications & Compliances:

- Connectors UL certified to UL6703 & UL1703, TUV certified, IP67 or IP68 rated
- Wire/cable UL certified to UL4703/UL854

Material Characteristics:

- RoHS compliant
- Cross linked polyethylene wire (XLPE or XLP)
- Flammability meets UL 94 requirements; V0 rated

Solar Whip Assemblies



Whip Assembly

#10 AWG wire – 35A current capacity*

#12 AWG wire – 25A current capacity*

#14 AWG wire – 20A current capacity*

- Designed for exposed or concealed wet or dry locations
- Sunlight-resistant
- Rated for direct burial
- Rodent proof jacket
- Temperature range: -40°C to +90°C

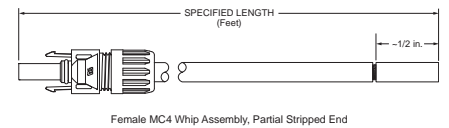
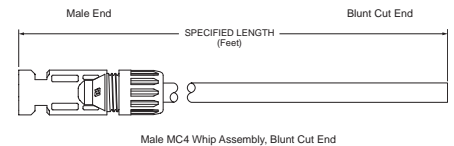

*Recommended (not to exceed). Each system is unique and the design should consider all factors including current de-rating.

Solar Jumper Assembly



Jumper Assembly

#10 AWG wire – 35A current capacity*

#12 AWG wire – 25A current capacity*

#14 AWG wire – 20A current capacity*

- Designed for exposed or concealed wet or dry locations
- Sunlight-resistant
- Rated for direct burial
- Rodent proof jacket
- Temperature range: -40°C to +90°C

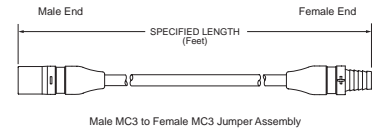
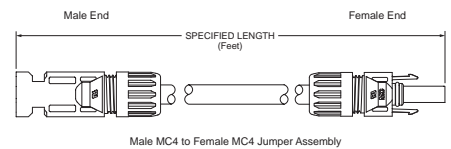

*Recommended (not to exceed). Each system is unique and the design should consider all factors including current de-rating.



Sunconnector™ Whip & Jumper Assemblies

600V, 1000V and 2000V DC
20A, 25A or 35A
IP67 or IP68

Connection Types

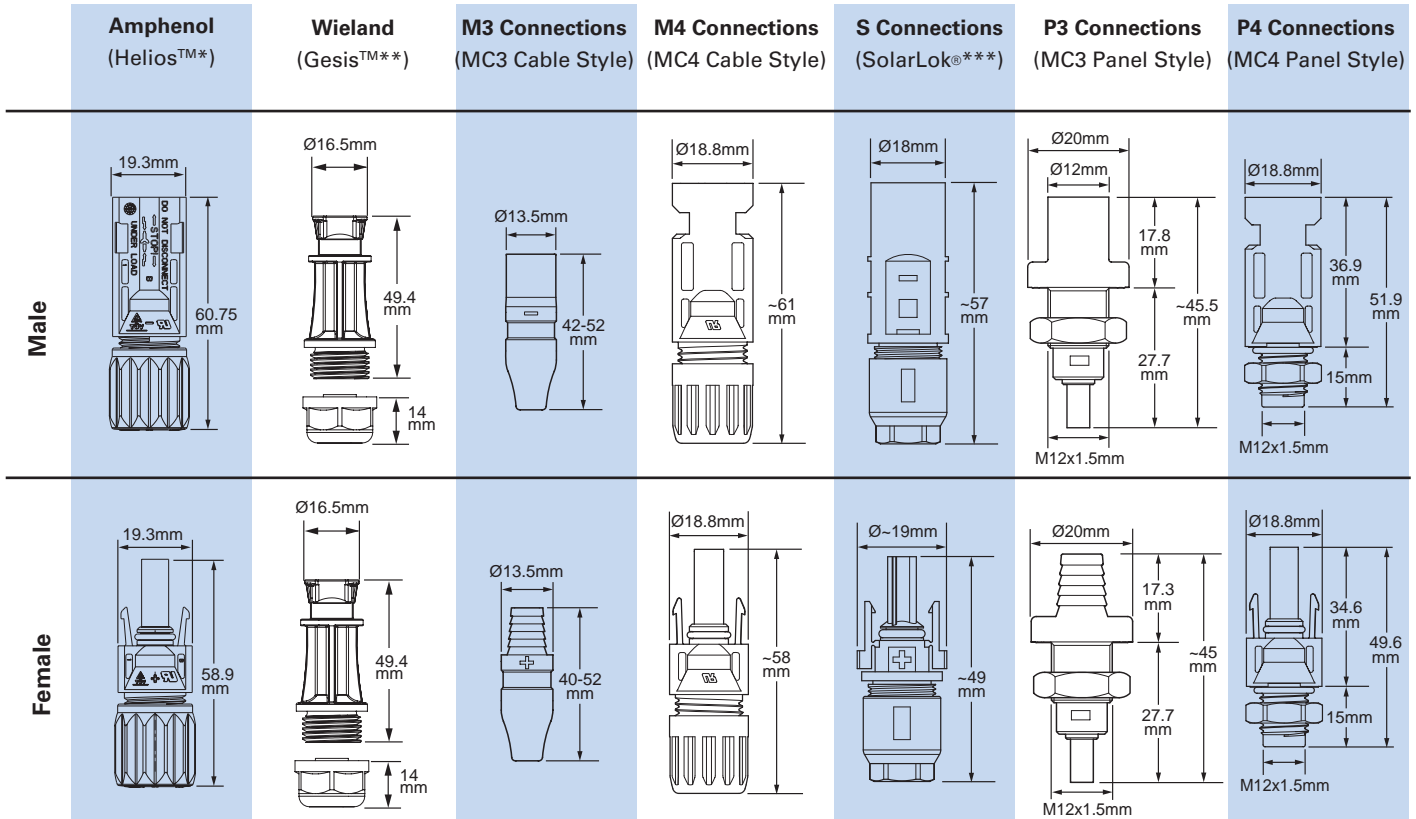

*Helios is a trademark of Amphenol **Gesis is a trademark of Wieland ***Solar Lok is a trademark of Tyco

Whip & Jumper Assemblies Catalog Number Matrix

Sample Number: **M3M126B-M3F20** = MC3 male to MC3 female jumper, 12 AWG, 600V rated USE-2, black wire, 20 feet long.

M3M 12 6 B M3F 20

Assembly End 1 Connector Type*	Wire AWG	Wire Voltage Rating	Cable Jacket Color	Assembly End 2 Type*	Length (feet)	
M3M = MC3 Male M4M = MC4 Male H4M = Amphenol Male W4M = Wieland Male SMP = SolarLok® Male Pos SMN = SolarLok® Male Neg SMU = SolarLok® Male Neutral P3M = MC3 Male Panel P4M = MC4 Male Panel M3F = MC3 Female M4F = MC4 Female H4F = Amphenol Female W4F = Wieland Female SFP = SolarLok® Female Pos SFN = SolarLok® Female Neg P3F = MC3 Female Panel P4F = MC4 Female Panel PSP = SolarLok® Male Pos Panel PSN = SolarLok® Male Neg Panel PHM = Amphenol Male Panel PHF = Amphenol Female Panel	+ Assembly end 1 connectors are female only if assembly end 2 connector is also female. 14 = #14 AWG 12 = #12 AWG 10 = #10 AWG 08 = #8 AWG	6 = 600V USE-2 2 = 2000V PV 3 = 1000V RWU90	B = Black W = White R = Red (Other colors available, consult customer service)	BC = Blunt Cut Wire PS = Partial Stripped Wire Connector, for Jumpers: M3F = MC3 Female M4F = MC4 Female H4F = Amphenol Female W4F = Wieland Female SF = SolarLok® Female P3F = MC3 Female Panel	Connector, for Jumpers: P4F = MC4 Female Panel M3M = MC3 Male M3M = MC4 Male M4M = MC4 Male H4M = Amphenol Male W4M = Wieland Male SM = SolarLok® Male P3M = MC3 Male Panel P4M = MC4 Male Panel	1-999

+ Assembly end 1 connectors are female only if assembly end 2 connector is also female.

Sunconnector™ Parallel Circuit Array & Home Run Harness Assemblies

Sophisticated solar construction requires clever solutions

An efficient solar field layout nets optimum performance and generates returns for many years. Sunconnector™ custom assemblies simplify your project and eliminate on-site waste.

ENGINEERED SOLUTIONS DESIGNED SPECIFICALLY FOR EACH INDIVIDUAL JOB

Intelligent cabling solutions provide the best overall value and design flexibility to get the job done right.

Applications:

- Custom made Parallel Circuit Array and Home Run (Sub-array) harnesses provide flexibility while delivering cost savings to any large solar installation.
- Sunconnector™ Parallel Circuit Array Harness Assemblies feature a proprietary junction system that allows multiple arrays to be connected in parallel, providing labor savings and improving connection quality by eliminating multiple adapters and double terminations.
- Parallel Circuit Harnesses are ideal for thin film type modules, where low current can be electrically paralleled to optimize electrical output.
- Sunconnector™ Home Run Harnesses are designed for high current connection and power delivery to combiner boxes, sub-combiners or inverters used with monocrystalline and polycrystalline modules.
- Fully tested Sunconnector™ Home Run Harnesses arrive terminated, bundled and spooled, replacing on-site long wire runs, bundling, attachment and connector termination.
- Home Run Harnesses can also be manufactured with easy-to-read identification on each leg and on spools; spools can also be labeled for proper job site placement.



Custom Parallel Circuit Array Harness

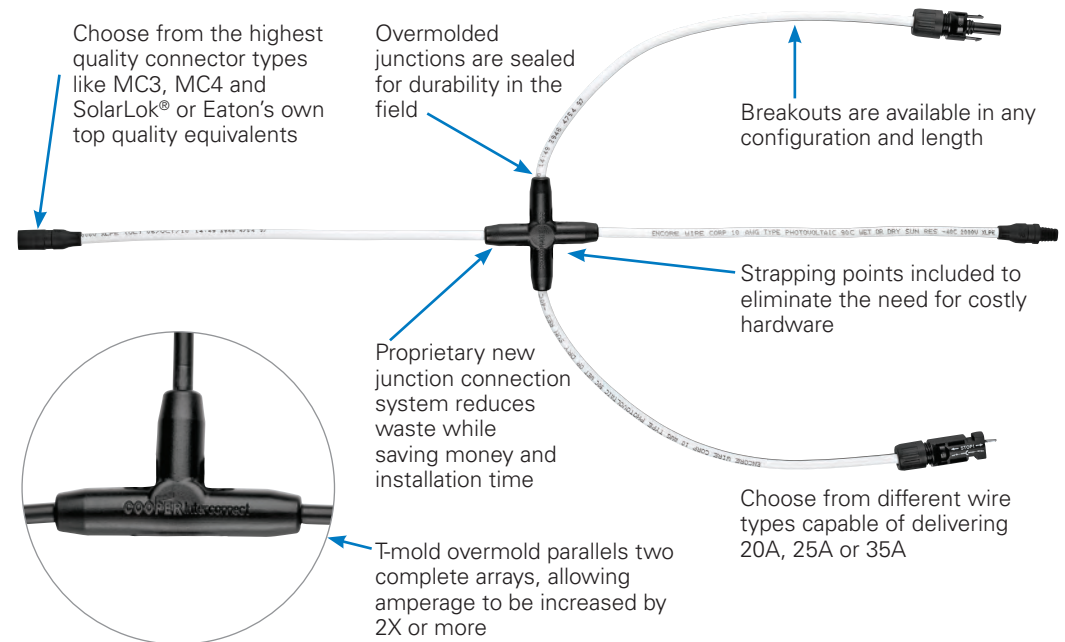

Custom Solar Home Run Harness

Wires are processed with Swiss made precision equipment

In-line circuit protection is available with PV rated fuses and fuse holders

Assemblies are 100% fully factory tested and offer superior weatherproof sealing

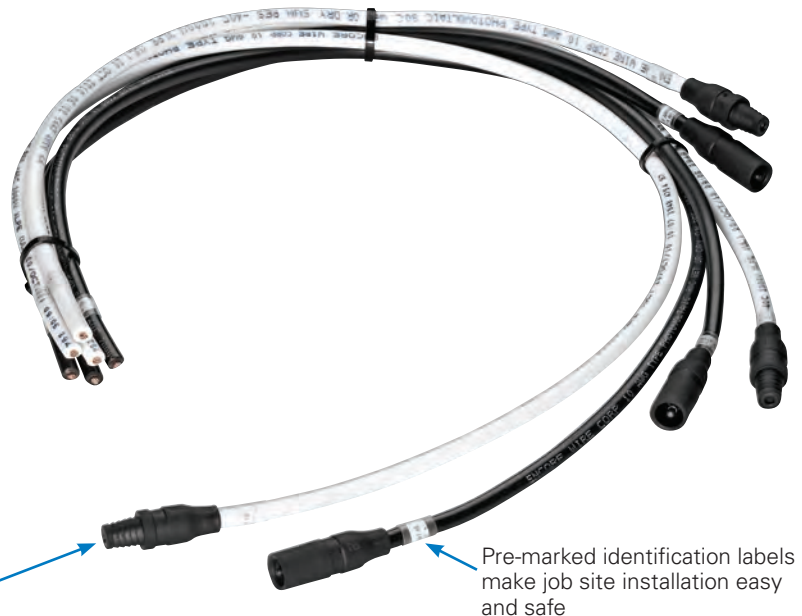

Sunnector™ Solar Parallel Circuit Harness Assemblies

600V, 1000V and 2000V DC
 20A, 25A or 35A
 IP67 or IP68

Custom Parallel Circuit Array Harness Assemblies

Features:

- Unique solution that is specifically designed to optimize the electrical outputs of thin film modules
- Provides a better solution by eliminating the need for costly adapters, double the connectors and failure points
- Proprietary molding and sealing process stems from years of research and performance in harsh environments
- Superior sealing performance of overmolded connectors/junctions.
- Pre-assembled, delivered to job site
- Fully tested for continuity and hi-pot for dependable field performance
- Improved durability and strain relief over traditional wiring

- Custom T- or X-mold strapping points permit attachment of harnesses without clamps
- Proven high performance materials
- UV and ozone resistant
- All X-mold and T-mold harnesses are available with termination points in the connector of your choice
- Harnesses can reliably connect as many as 374† modules per harness (when utilizing #10 AWG PV wire)
- ID labeling available to communicate point-to-point connections in the field

Certifications and Compliances:

- Connectors UL certified to UL6703 & UL1703, TUV certified, IP67 or IP68 rated
- Wire/cable UL certified to UL4703/UL854

Material Characteristics:

- RoHS compliant
- Cross linked polyethylene wire (XLPE or XLP)
- Flammability meets UL 94 requirements; V0 rated



X-mold Parallel Circuit Array Harness Assembly



T-mold Parallel Circuit Array Harness Assembly



X-mold Option



T-mold Option

Parallel Circuit Array Harness Assemblies

#10 AWG wire – 35A current capacity*

#12 AWG wire – 25A current capacity*

#14 AWG wire – 20A current capacity*

- Designed for exposed or concealed wet or dry locations
- Sunlight-resistant
- Rated for direct burial
- Rodent proof jacket
- Temperature range: -40°C to +90°C

* Recommended (not to exceed). Each system is unique and the design should consider all factors including current de-rating.

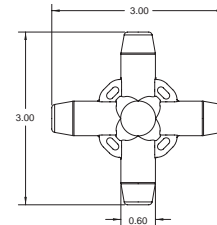

Custom Harness Assembly T-Mold Junction

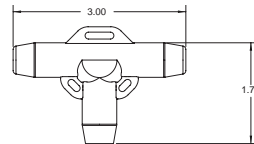
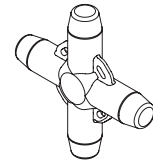

Custom Harness Assembly T-Mold Junction

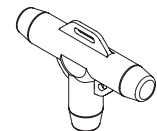

Custom Harness Assembly Ordering Information

Whether you need to create complex or simple systems, contact your local Eaton's Crouse-Hinds Division Sales Representative and we will help you develop the most efficient system possible. Order Sunnector™ Parallel Circuit Array Harness Assemblies by sending the following two items to EngineeringSunnector@Eaton.com:

1. A completed copy of our Solar Installation Questionnaire that can be downloaded from this web page: <http://www.crouse-hinds.com/solarassemblies>
2. A system diagram with electrical parameters and module locations



†The number of modules listed is only for reference and is not meant to be an electrical guide.

Sunnector™ Solar Parallel Circuit Harness Assemblies

600V, 1000V and 2000V DC
20A, 25A or 35A
IP67 or IP68

Custom Parallel Circuit Array Harness Assemblies Configurations

- Ideal for installations where modules are electrically paralleled with multiple arrays integrating to one combiner box or inverter
- The X-mold junction conveniently merges module arrays while allowing multiple connection points on each leg
- Harnesses made with T-mold junctions provide a quick and easy way to connect module arrays to a combiner box
- Suitable for use for residential, commercial and utility scale projects, harnesses are available with an unlimited number of branches
- Module arrays with low current output are easily paralleled to optimize the maximum current output while providing design flexibility and cost and labor savings
- Custom designed Sunnector™ assemblies reduce the overall installed cost by 10% to 35%*

Combination X-mold & T-mold Junction Wiring Configuration

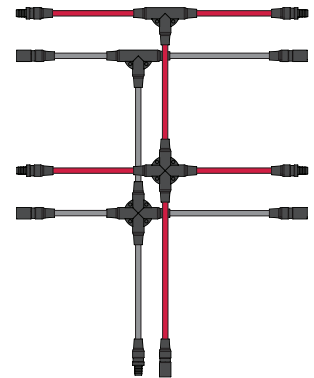
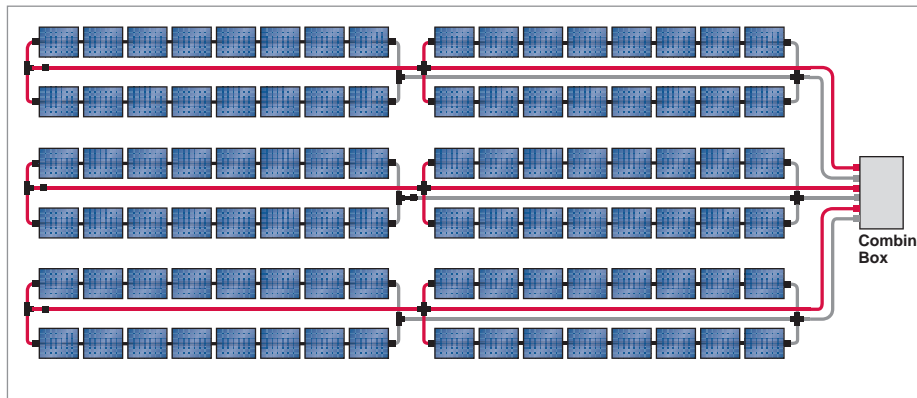

In this example, 98 modules can be connected using a Sunnector™ Custom Parallel X- and T-mold junction harness to provide a 3-string circuit to the combiner box. No need to run 24 discrete wires back to the combiner.

T-mold Junction Wiring Configuration

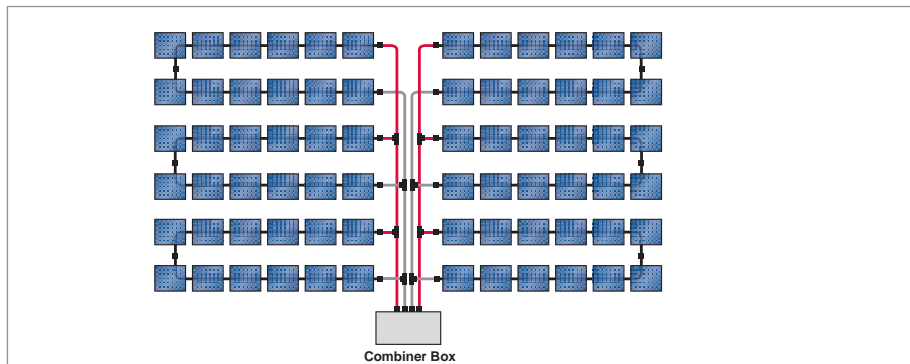

In this example, 72 modules can be connected using only 2 Sunnector™ parallel harnesses: simple, cost-effective and reliable.

*Based on labor and material savings versus traditional wiring.

Sunconnector™ Solar Home Run Harness Assemblies

600V, 1000V and 2000V DC
20A, 25A or 35A
IP67 or IP68

Custom Home Run Harness Assemblies

Features:

- Designed for high current connection and power delivery to combiner boxes, sub-combiners, or inverters used with monocrystalline and polycrystalline modules
- Pre-built assemblies are designed specifically for each job and application
- IP67 or IP68 waterproof rated dependent on connector type
- UV- and ozone-resistant
- Fully tested for continuity and hi-pot for dependable field performance
- Overmolded connectors/junctions deliver superior sealing performance
- Improved durability and strain relief over traditional wiring
- Save money and time by facilitating quicker installation
- Proven high performance TPE, PPO and PC materials
- All Home Run Harnesses are available with termination points in the connector of your choice
- Available with #14, #12 or #10 AWG wires
- ID labeling available to communicate point-to-point connections in the field
- Delivered pre-assembled; job site delivery is also available

Certifications and Compliances:

- Connectors UL certified to UL6703 & UL1703, TUV certified, IP67 or IP68 rated
- Wire/cable UL certified to UL4703/UL854

Material Characteristics:

- RoHS compliant
- Cross linked polyethylene wire (XLPE or XLP)
- Flammability meets UL 94 requirements; V0 rated



Home Run Harness Assembly

Home Run Harness Assemblies

#10 AWG wire – 35A current capacity*

#12 AWG wire – 25A current capacity*

#14 AWG wire – 20A current capacity*

- Designed for exposed or concealed wet or dry locations
- Sunlight-resistant
- Rated for direct burial
- Rodent proof jacket
- Temperature range: -40°C to +90°C

*Recommended (not to exceed). Each system is unique and the design should consider all factors including current de-rating.



Custom Labeling Options

Custom Harness Assembly Ordering Information

Whether you need to create complex or simple systems, contact your local Eaton's Crouse-Hinds Division Sales Representative and we will help you develop the most efficient system possible. Order Sunconnector™ Parallel Circuit Array Harness Assemblies by sending the following two items to EngineeringSunconnector@Eaton.com:

1. A completed copy of our Solar Installation Questionnaire that can be downloaded from this web page: <http://www.crouse-hinds.com/solarassemblies>
2. A system diagram with electrical parameters and module locations

†The number of modules listed is only for reference and is not meant to be an electrical guide.

*Based on labor and material savings versus traditional wiring.

Sunconnector™ Solar Home Run Harness Assemblies

600V, 1000V and 2000V DC
20A, 25A or 35A
IP67 or IP68

Custom Home Run Harness Assemblies Configurations

- Home Run Harnesses are one of the most functional products for large utility scale or commercial systems
- Gathers individual strings from the module array and are bundled, labeled and conveniently coiled on a spool for quick and easy unreeling
- Eliminates the need for unreeling individual wires, cutting, stripping, terminating, labeling, tie-wrapping and assembling connectors
- Spools can be placed at the combiner box and unreeled in one fast and easy process
- Easy to read, long-lasting labels make connection to the modules and combiner box a snap
- Most commonly available from 2-8 strings (4 to 16 discrete wires), Eaton can provide any length and/or breakout you require
- Custom designed Sunconnector™ assemblies reduce the overall installed cost by 10% to 35%*

30 Solar Module Configuration

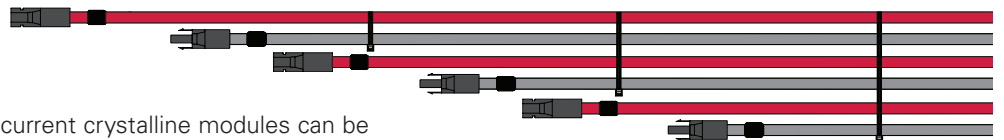
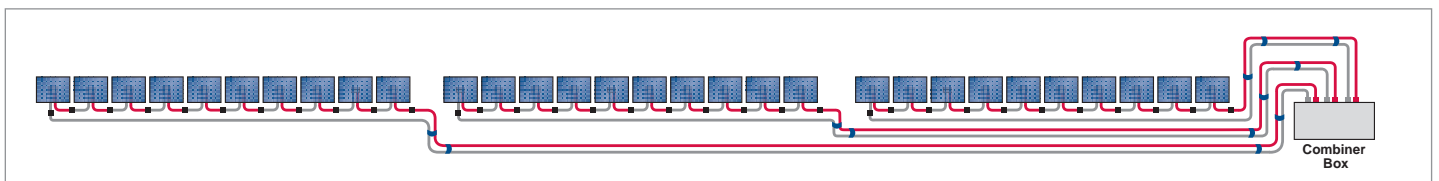

This example represents how 30 high current crystalline modules can be connected using only 3 Sunconnector™ parallel harnesses. This pre-spooled Home Run Harness was installed with only 6 connections.

60 Solar Module Configuration

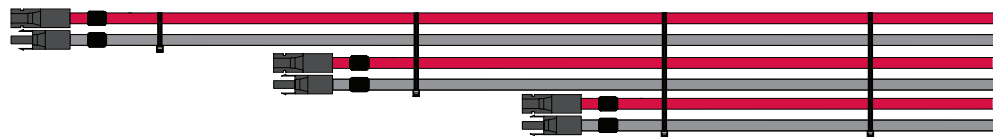
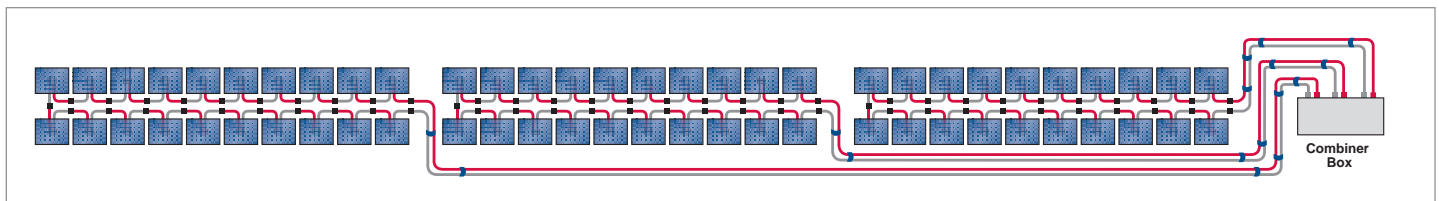

This example shows how 60 crystalline modules can be connected using only 3 Sunconnector™ parallel harnesses: simple, cost-effective and reliable.



Commercial Products delivers quality, reliability, labor savings and lower installed cost, all from a single dependable source.

See the complete offering of Commercial Products at www.crouse-hinds.com.

U.S. (Global Headquarters): Eaton's Crouse-Hinds Business

1201 Wolf Street
Syracuse, NY 13208
(866) 764-5454
FAX: (315) 477-5179
Orders Only:
ECHUSAOrders@eaton.com
CrouseCustomerCTR@eaton.com

For more information:

If further assistance is required, please contact an authorized Eaton Distributor, Sales Office, or Customer Service Department.

Canada:

Toll Free: 800-265-0502
FAX: (800) 263-9504
FAX Orders only: (866) 653-0645

Mexico/Latin America/Caribbean:

52-555-804-4000
FAX: 52-555-804-4020
ventascentromex@eaton.com

Europe (Germany):

49 (0) 6271 806-500
49 (0) 6271 806-476
sales.CCH.de@cooperindustries.com

Middle East (Dubai):

971 4 8066100
FAX: 971 4 8894813
chmesales@eaton.com

Singapore:

65-6645-9888
FAX: 65-6297-4819
chsi-sales@cooperindustries.com

China:

86-21-2899-3600
FAX: 86-21-2899-4055
cchsales@cooperindustries.com

Korea:

82-2-3484-6783
82-2-3484-6778
CCHK-sales@cooperindustries.com

Australia:

61-2-8787-2777
FAX: 61-2-9609-2342
CEASales@cooperindustries.com

India:

91-124-4683888
FAX: 91-124-4683899
cchindia@eaton.com

Eaton
1000 Eaton Boulevard
Cleveland, OH 44122
United States
Eaton.com

© 2016 Eaton Corporation
All Rights Reserved
Printed in USA
Form No. 5142-0516
May 2016

Eaton's Crouse-Hinds Business
1201 Wolf Street
Syracuse, NY 13208
(866) 764-5454
CrouseCustomerCTR@eaton.com

Eaton is a registered trademark.

All other trademarks are property of their respective owners.