

SIEMENS

RUGGEDCOM M969

Installation Guide

Preface

Introduction

1

Installing the Device

2

Device Management

3

Communication Ports

4

Technical Specifications

5

Accessories

6

Certification

7

Copyright © 2018 Siemens Canada Ltd

All rights reserved. Dissemination or reproduction of this document, or evaluation and communication of its contents, is not authorized except where expressly permitted. Violations are liable for damages. All rights reserved, particularly for the purposes of patent application or trademark registration.

This document contains proprietary information, which is protected by copyright. All rights are reserved. No part of this document may be photocopied, reproduced or translated to another language without the prior written consent of Siemens Canada Ltd.

» Disclaimer Of Liability

Siemens has verified the contents of this document against the hardware and/or software described. However, deviations between the product and the documentation may exist.

Siemens shall not be liable for any errors or omissions contained herein or for consequential damages in connection with the furnishing, performance, or use of this material.

The information given in this document is reviewed regularly and any necessary corrections will be included in subsequent editions. We appreciate any suggested improvements. We reserve the right to make technical improvements without notice.

» Registered Trademarks

RUGGEDCOM™ and ROS™ are trademarks of Siemens Canada Ltd.

Other designations in this manual might be trademarks whose use by third parties for their own purposes would infringe the rights of the owner.

» Third Party Copyrights

Siemens recognizes the following third party copyrights:

- Copyright © 2004 GoAhead Software, Inc. All Rights Reserved.

» Security Information

Siemens provides products and solutions with industrial security functions that support the secure operation of plants, machines, equipment and/or networks. They are important components in a holistic industrial security concept. With this in mind, Siemens' products and solutions undergo continuous development. Siemens recommends strongly that you regularly check for product updates.

For the secure operation of Siemens products and solutions, it is necessary to take suitable preventive action (e.g. cell protection concept) and integrate each component into a holistic, state-of-the-art industrial security concept. Third-party products that may be in use should also be considered. For more information about industrial security, visit <https://www.siemens.com/industrialsecurity>.

To stay informed about product updates as they occur, sign up for a product-specific newsletter. For more information, visit <https://support.automation.siemens.com>.

» Warranty

Siemens warrants this product for a period of five (5) years from the date of purchase, conditional upon the return to factory for maintenance during the warranty term. This product contains no user-serviceable parts. Attempted service by unauthorized personnel shall render all warranties null and void. The warranties set forth in this article are exclusive and are in lieu of all other warranties, performance guarantees and conditions whether written or oral, statutory, express or implied (including all warranties and conditions of merchantability and fitness for a particular purpose, and all warranties and conditions arising from course of dealing or usage or trade). Correction of nonconformities in the manner and for the period of time provided above shall constitute the Seller's sole liability and the Customer's exclusive remedy for defective or nonconforming goods or services whether claims of the Customer are based in contract (including fundamental breach), in tort (including negligence and strict liability) or otherwise.

For warranty details, visit <https://www.siemens.com/ruggedcom> or contact a Siemens customer service representative.

» Contacting Siemens

Address

Siemens Canada Ltd
Industry Sector
300 Applewood Crescent
Concord, Ontario
Canada, L4K 5C7

Telephone

Toll-free: 1 888 264 0006
Tel: +1 905 856 5288
Fax: +1 905 856 1995

E-mail

ruggedcom.info.i-ia@siemens.com

Web

<https://www.siemens.com/ruggedcom>

Table of Contents

Preface	vii
Alerts	vii
Related Documents	viii
Accessing Documentation	viii
Training	viii
Customer Support	viii
 Chapter 1	
Introduction	1
1.1 Feature Highlights	1
1.2 Description	2
1.3 Required Tools and Materials	5
1.4 Cabling Recommendations	5
1.4.1 Supported Fiber Optic Cables	6
1.5 Ingress Protection	6
1.6 Decommissioning and Disposal	7
 Chapter 2	
Installing the Device	9
2.1 General Procedure	9
2.2 Unpacking the Device	10
2.3 Mounting the Device	10
2.4 Connecting the Failsafe Alarm Relay	11
2.5 Connecting Power	12
2.5.1 Power Supply Connector Pin-Out	12
2.5.2 Power Supply Wiring	13
2.5.3 Disabling Line-to-Ground Transient Protection	15
 Chapter 3	
Device Management	17
3.1 Connecting to the Device	17
3.2 Configuring the Device	18
 Chapter 4	
Communication Ports	19
4.1 Copper Ethernet Ports	20

4.2 Fiber Optic Ethernet Ports	21
Chapter 5	
Technical Specifications	23
5.1 Power Supply Specifications	23
5.2 Failsafe Alarm Relay Specifications	23
5.3 Copper Ethernet Port Specifications	24
5.4 Fiber Optic Ethernet Port Specifications	24
5.5 Operating Environment	25
5.6 Mechanical Specifications	25
5.7 Dimension Drawings	26
Chapter 6	
Accessories	29
6.1 Power (1/unit)	29
6.2 Console (1/unit)	30
6.3 Failsafe (1/unit)	31
6.4 Ethernet (8/unit)	32
6.5 LC Fiber Optic (2/unit)	35
Chapter 7	
Certification	39
7.1 Approvals	39
7.1.1 CSA	39
7.1.2 European Commission (EC)	40
7.1.3 FCC	40
7.1.4 FDA/CDRH	40
7.1.5 ISED	41
7.1.6 ACMA	41
7.1.7 RoHS	41
7.1.8 Other Approvals	42
7.2 MIL-STD Test Specifications	42
7.3 EMC and Environmental Type Tests	43

Preface

This guide describes the RUGGEDCOM M969. It describes the major features of the device, installation, commissioning and important technical specifications.

It is intended for use by network technical support personnel who are responsible for the installation, commissioning and maintenance of the device. It is also recommended for use by network and system planners, system programmers, and line technicians.

CONTENTS

- [“Alerts”](#)
- [“Related Documents”](#)
- [“Accessing Documentation”](#)
- [“Training”](#)
- [“Customer Support”](#)

Alerts

The following types of alerts are used when necessary to highlight important information.



DANGER!

DANGER alerts describe imminently hazardous situations that, if not avoided, will result in death or serious injury.



WARNING!

WARNING alerts describe hazardous situations that, if not avoided, may result in serious injury and/or equipment damage.



CAUTION!

CAUTION alerts describe hazardous situations that, if not avoided, may result in equipment damage.



IMPORTANT!

IMPORTANT alerts provide important information that should be known before performing a procedure or step, or using a feature.



NOTE

NOTE alerts provide additional information, such as facts, tips and details.

Related Documents

Other documents that may be of interest include:

- [RUGGEDCOM ROS User Guide](https://support.industry.siemens.com/cs/ww/en/view/109737231) [https://support.industry.siemens.com/cs/ww/en/view/109737231]

Accessing Documentation

The latest user documentation for RUGGEDCOM M969 is available online at <https://www.siemens.com/ruggedcom>. To request or inquire about a user document, contact Siemens Customer Support.

Training

Siemens offers a wide range of educational services ranging from in-house training of standard courses on networking, Ethernet switches and routers, to on-site customized courses tailored to the customer's needs, experience and application.

Siemens' Educational Services team thrives on providing our customers with the essential practical skills to make sure users have the right knowledge and expertise to understand the various technologies associated with critical communications network infrastructure technologies.

Siemens' unique mix of IT/Telecommunications expertise combined with domain knowledge in the utility, transportation and industrial markets, allows Siemens to provide training specific to the customer's application.

For more information about training services and course availability, visit <https://www.siemens.com/ruggedcom> or contact a Siemens Sales representative.

Customer Support

Customer support is available 24 hours, 7 days a week for all Siemens customers. For technical support or general information, contact Siemens Customer Support through any of the following methods:



Online

Visit <http://www.siemens.com/automation/support-request> to submit a Support Request (SR) or check on the status of an existing SR.

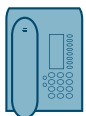

Telephone

Call a local hotline center to submit a Support Request (SR). To locate a local hotline center, visit <http://www.automation.siemens.com/mcms/aspa-db/en/automation-technology/Pages/default.aspx>.



Mobile App

Install the Industry Online Support app by Siemens AG on any Android, Apple iOS or Windows mobile device and be able to:

- Access Siemens' extensive library of support documentation, including FAQs and manuals
- Submit SRs or check on the status of an existing SR

- Contact a local Siemens representative from Sales, Technical Support, Training, etc.
- Ask questions or share knowledge with fellow Siemens customers and the support community

1 Introduction

The RUGGEDCOM M969 is a MIL-STD hardened, fully managed Ethernet switch providing dual fiber optical Fast Ethernet or Gigabit Ethernet ports and eight Fast Ethernet copper ports in a MIL-STD 901D rated package (for protection against vibration and shock impacts) and is IP65/IP67 rated for protection against strong jets of water (IP65) or temporary immersion in water (IP67).

Designed to operate reliably in harsh environments, the RUGGEDCOM M969 provides a high level of tolerance to vibrations and shock impact; high level of immunity to electromagnetic interference; an operating temperature range of -40 to 85 °C (40 to 185 °F); hazardous location certification and IP65/IP67 rated waterproof packaging. All of which allows the RUGGEDCOM M969 to be placed in virtually any location.

The embedded RUGGEDCOM Rugged Operating System (ROS) provides advanced layer 2 and layer 3 networking functions, advanced cyber security features, and a full array of intelligent functionality for high network availability and manageability. Coupled with the ruggedized hardware design, the RUGGEDCOM M969 is ideal for creating mission-critical, real-time, control applications in any harsh environment.

CONTENTS

- [Section 1.1, "Feature Highlights"](#)
- [Section 1.2, "Description"](#)
- [Section 1.3, "Required Tools and Materials"](#)
- [Section 1.4, "Cabling Recommendations"](#)
- [Section 1.5, "Ingress Protection"](#)
- [Section 1.6, "Decommissioning and Disposal"](#)

Section 1.1

Feature Highlights

» Ethernet Ports

- Two Fiber Optical Fast Ethernet Ports (100Base-X) or Gigabit Ethernet Ports (1000Base-X)
- Eight Fast Ethernet Ports (10/100Base-TX) with IP65/IP67 Rated M12 D-code connectors or IP65/IP67 Rated shrouded RJ45 style connectors
- Full compliance with IEEE: 802.3, 802.3u and 802.3z
- Non-blocking, store and forward switching
- Full duplex operation and flow control (IEEE 802.3x)

» RuggedRated for Reliability in Harsh Environments

- IP67 rated for protection against immersion in water
- IP65 rated for protection against high pressure jets of water
- Hazardous location certification: Class 1 Division 2
- -40 to 85 °C (40 to 185 °F) operating temperature (no fans)
- Conformal coated circuit boards (optional)
- Failsafe output relay for critical failure or error alarming

» Universal Power Supply Options

- Fully integrated power supply
- Universal high-voltage range: 88-300 VDC or 85-264 VAC.
- Popular low-voltage DC ranges: 12, 24, 48 VDC
- Dual redundant, parallel load-sharing power supplies (option)
- Can be powered from different sources for ultimate redundancy
- Available with M23 style connectors
- CSA/UL 60950-1 safety approved to 85 °C (185 °F)

» Simple Plug and Play Operation

- Automatic learning of up to 8192 MAC addresses
- Auto-negotiation on all 10/100Base-TX ports, 100FX on optic fiber ports
- Auto-MDI/MDIX (crossover) on all 10/100Base-TX ports
- LED indicators for link and activity

Section 1.2

Description

The RUGGEDCOM M969 features various ports, controls and indicator LEDs for connecting, configuring and troubleshooting the device.

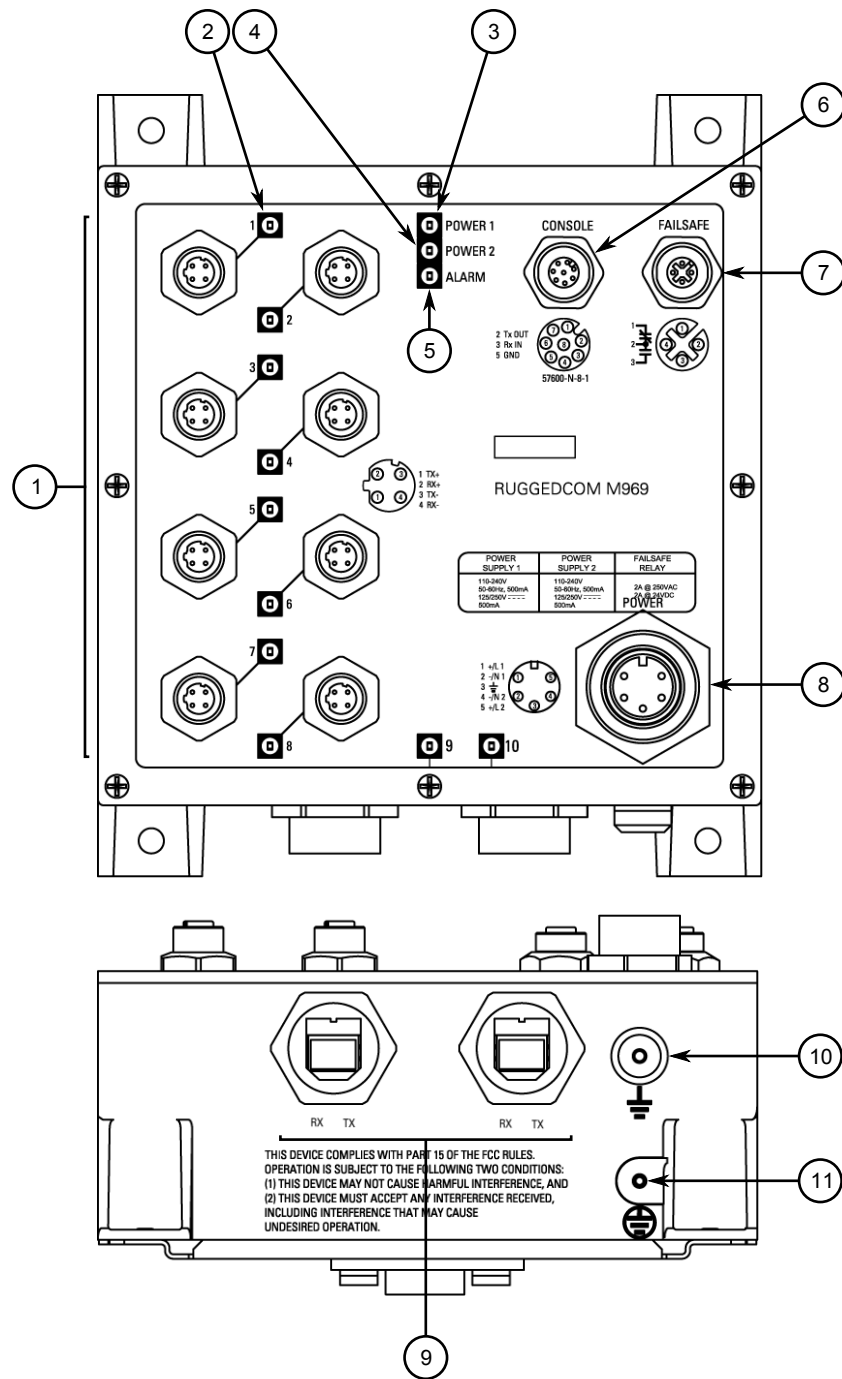

Figure 1: RUGGEDCOM M969 (M12 Connectors Shown)

1. Copper Ethernet Ports 2. Port Status LED 3. POWER 1 LED 4. POWER 2 LED 5. ALARM LED 6. RS-232 Console Port 7. Failsafe Output Relay 8. M12 Power Supply Port 9. Fiber Optic Ethernet Ports 10. Surge Ground Connection 11. Chassis Ground Connection

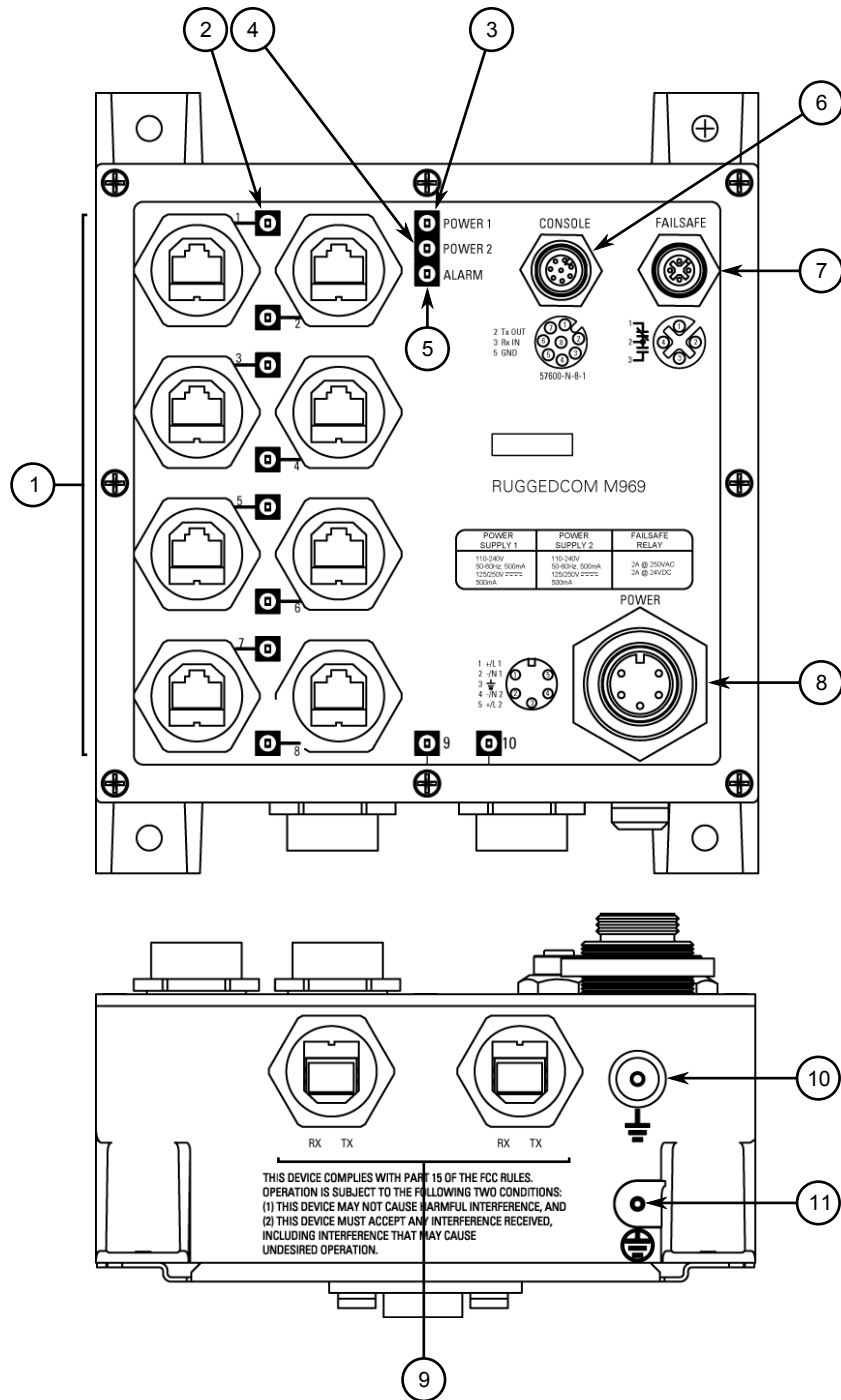

Figure 2: RUGGEDCOM M969 (RJ45 Connectors Shown)

1. Copper Ethernet Ports 2. Port Status LED 3. POWER 1 LED 4. POWER 2 LED 5. ALARM LED 6. RS-232 Console Port 7. Failsafe Output Relay 8. M23 Power Supply Port 9. Fiber Optic Ethernet Ports 10. Surge Ground Connection 11. Chassis Ground Connection

Port Status LED

Indicate the status of each port.

State	Description
Yellow (Solid)	Link established
Yellow (Blinking)	Link activity
Off	No activity

POWER LED 1/POWER LED 2	Illuminates when power is supplied to the associated internal power supply.
ALARM LED	Indicates when an alarm condition exists.
Failsafe Alarm Relay	Latches to default state when a power disruption or other alarm condition occurs. For more information, refer to: <ul style="list-style-type: none"> • Section 2.4, "Connecting the Failsafe Alarm Relay" • Section 5.2, "Failsafe Alarm Relay Specifications"
Power Supply Terminal	The power supply port. For more information, refer to: <ul style="list-style-type: none"> • Section 2.5, "Connecting Power" • Section 5.1, "Power Supply Specifications"
RS-232 Console Port	For interfacing directly with the device and accessing initial management functions. For information about connecting to the device via the console port, refer to Section 3.1, "Connecting to the Device" .
Copper/Fiber Ethernet Ports	For information about available copper and fiber Ethernet ports, refer to Chapter 4, Communication Ports .

Section 1.3

Required Tools and Materials

The following tools and materials are required to install the RUGGEDCOM M969:

Tools/Materials	Purpose
AC or DC power cord (16 AWG)	For connecting power to the device.
CAT-5 Ethernet cables	For connecting the device to the network.
Phillips screwdriver	For mounting the device to a panel.
4 x #6-32 screws	For mounting the device to a panel.

Section 1.4

Cabling Recommendations

Siemens recommends using RUGGEDCOM industrial Ethernet shielded cables for all Ethernet ports.

Siemens does not recommend the use of copper cabling of any length for critical, real-time substation automation applications. All copper Ethernet ports on RUGGEDCOM products include transient suppression circuitry to protect against damage from electrical transients and conform with IEC 61850-3 and IEEE 1613 Class 1 standards. This means that during a transient electrical event, communications errors or interruptions may occur, but recovery is automatic.

Siemens also does not recommend using copper Ethernet ports to interface with devices in the field across distances that could produce high levels of ground potential rise (i.e. greater than 2500 V), during line-to-ground fault conditions.

CONTENTS

- [Section 1.4.1, "Supported Fiber Optic Cables"](#)

Section 1.4.1

Supported Fiber Optic Cables

The following fiber optic cable types are supported under the stated conditions.

Cable Type	Wavelength (nm)	Modal Bandwidth (MHz·km)	Distance (m)		
			100Base-FX	1000Base-SX	10GBase-SR
OM1 (62.5/125)	850	200	—	275	33
	1300	500	2000	—	—
OM2 (50/125)	850	500	—	550	82
	1300	500	2000	—	—
OM3 (50/125) ^a	850	1500	—	550	300
	1300	500	2000	—	—
OM4 (50/125) ^a	850	3500	—	550	400
	1300	500	2000	—	—

^a Laser optimized.

Section 1.5

Ingress Protection

IEC International Standard 60529 (Edition 2.1: 2001-02) is a "classification of degrees of protection provided by enclosures as a system for specifying the enclosures of electrical equipment on the basis of the degree of protection provided by the enclosure." These ratings are determined by specific tests.

The RUGGEDCOM M969 Industrial Ethernet Switch is manufactured and tested to IP67 standards. With an IP67 rating a product will be "dust tight" and remain completely sealed when immersed in water to a depth of 1 meter for 1 hour (IEC 60529).

These caps completely seal off unused ports on the IP67 Industrial Ethernet Switch. It has an IP67 rated seal that keeps out all contaminants like dirt, oil, and water.



Section 1.6

Decommissioning and Disposal

Proper decommissioning and disposal of this device is important to prevent malicious users from obtaining proprietary information and to protect the environment.

» Decommissioning

This device may include sensitive, proprietary data. Before taking the device out of service, either permanently or for maintenance by a third-party, make sure it has been fully decommissioned.

For more information, refer to the associated *User Guide*.

» Recycling and Disposal

For environmentally friendly recycling and disposal of this device and related accessories, contact a facility certified to dispose of waste electrical and electronic equipment. Recycling and disposal must be done in accordance with local regulations.

2 Installing the Device

This chapter describes how to install the device, including mounting the device, connecting power, and connecting the device to the network.



WARNING!

*Radiation hazard – risk of serious personal injury. This product contains a laser system and is classified as a **CLASS 1 LASER PRODUCT**. Use of controls or adjustments or performance of procedures other than those specified herein may result in hazardous radiation exposure.*



DANGER!

Electrocution hazard – risk of serious personal injury and/or damage to equipment. Before performing any maintenance tasks, make sure all power to the device has been disconnected and wait approximately two minutes for any remaining energy to dissipate.



IMPORTANT!

This product contains no user-serviceable parts. Attempted service by unauthorized personnel shall render all warranties null and void.

Changes or modifications not expressly approved by Siemens Canada Ltd could invalidate specifications, test results, and agency approvals, and void the user's authority to operate the equipment.



IMPORTANT!

*This product should be installed in a **restricted access location** where access can only be gained by authorized personnel who have been informed of the restrictions and any precautions that must be taken. Access must only be possible through the use of a tool, lock and key, or other means of security, and controlled by the authority responsible for the location.*

CONTENTS

- [Section 2.1, "General Procedure"](#)
- [Section 2.2, "Unpacking the Device"](#)
- [Section 2.3, "Mounting the Device"](#)
- [Section 2.4, "Connecting the Failsafe Alarm Relay"](#)
- [Section 2.5, "Connecting Power"](#)

Section 2.1

General Procedure

The general procedure for installing the device is as follows:

1. Review the relevant certification information for any regulatory requirements. For more information, refer to [Section 7.1, "Approvals"](#).
2. Mount the device.
3. Connect the failsafe alarm relay.
4. Connect power to the device and ground the device to safety Earth.
5. Connect the device to the network.
6. Configure the device.

Section 2.2

Unpacking the Device

When unpacking the device, do the following:

1. Inspect the package for damage before opening it.
2. Visually inspect each item in the package for any physical damage.
3. Verify all items are included.



IMPORTANT!

If any item is missing or damaged, contact Siemens for assistance.

Section 2.3

Mounting the Device

The RUGGEDCOM M969 is designed to be mounted on a panel by affixing the top and bottom flanges of the device to a panel using screws.



IMPORTANT!

Heat generated by the device is channeled outwards from the enclosure. As such, it is recommended that 2.5 cm (1 in) of space be maintained on all open sides of the device to allow for some convective airflow.

Forced airflow is not required. However, any increase in airflow will result in a reduction of ambient temperature and improve the long-term reliability of all equipment mounted in the rack space.



NOTE

For detailed dimensions of the device with panel mount hardware installed, refer to [Section 5.7, "Dimension Drawings"](#).

To mount the device to a panel, do the following:

1. Place the device against the panel and align the flanges with the mounting holes.

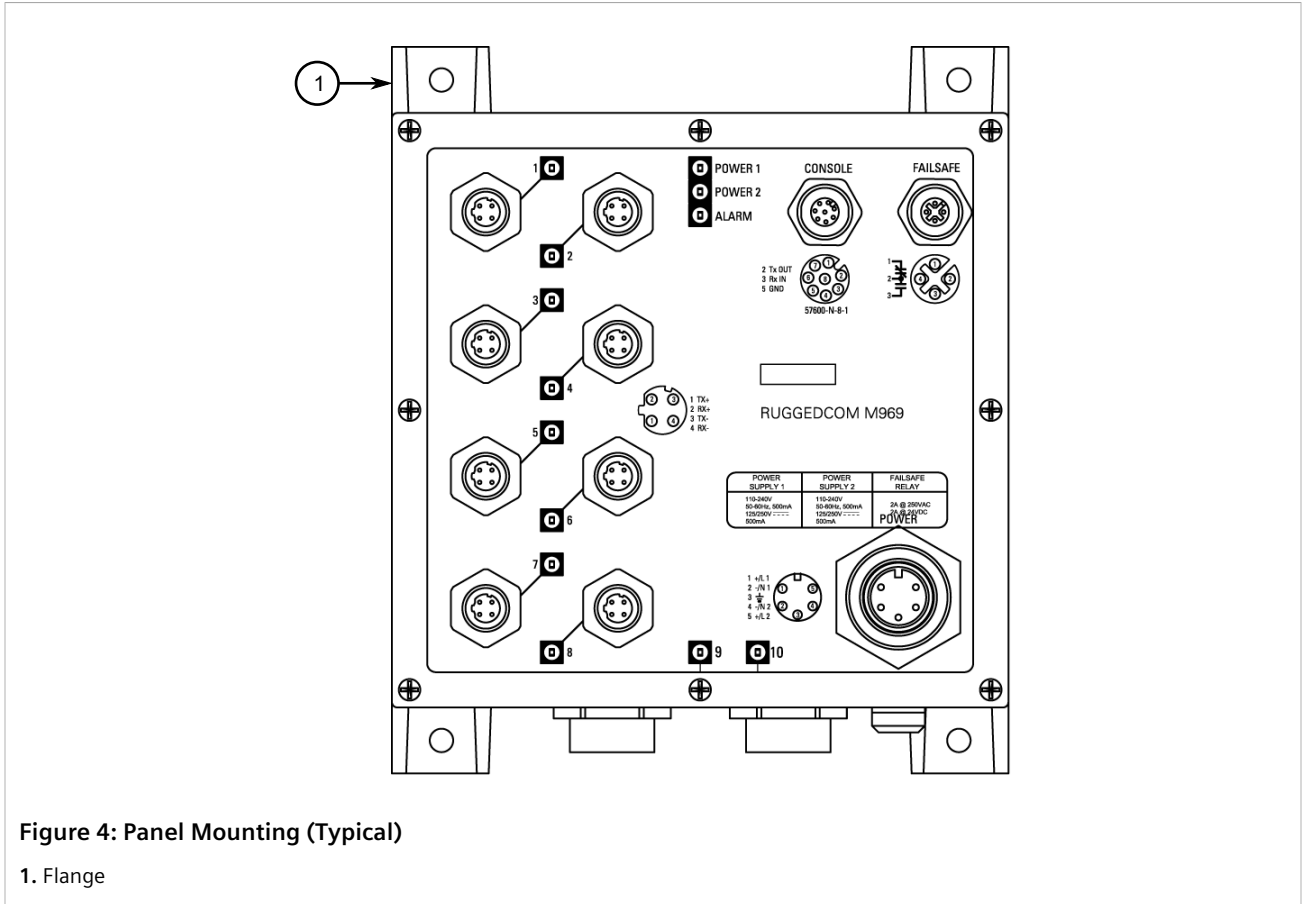

Figure 4: Panel Mounting (Typical)

1. Flange

2. Install the supplied screws to secure the flanges to the panel.

Section 2.4

Connecting the Failsafe Alarm Relay

The *Failsafe* output relay is provided to signal critical error conditions that may occur on the RUGGEDCOM M969 series switches. The contacts are energized upon power up of the unit and remain energized until a critical error occurs.

One common application for this output is to signal an alarm if a power failure or removal of control power occurs.

The proper relay connections are as follows:

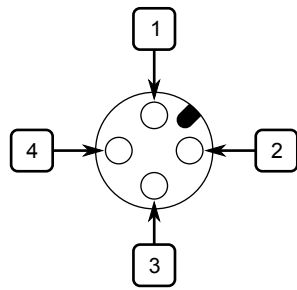

Figure 5: Failsafe Alarm Relay Wiring

Pin	Description
1	Normally Closed
2	Common
3	Normally Open

Section 2.5

Connecting Power

The M23 power connector has five terminal pins, which means two power supply sources are allowed to power the RUGGEDCOM M969 with the M23 power connector. The RUGGEDCOM M969 supports dual redundant power supplies: *Power Supply 1 (PS1)* and *Power Supply 2 (PS2)*.

CONTENTS

- [Section 2.5.1, "Power Supply Connector Pin-Out"](#)
- [Section 2.5.2, "Power Supply Wiring"](#)
- [Section 2.5.3, "Disabling Line-to-Ground Transient Protection"](#)

Section 2.5.1

Power Supply Connector Pin-Out

The following is the pin-out for the M23 A-coded power supply connector:

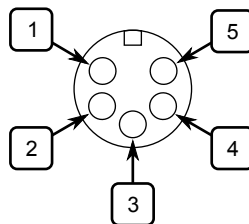

Figure 6: M23 Power Supply Connector

Terminal #	Description	Usage
1	PS1 Live/+	PS1 Live/+ is connected to the positive (+) terminal if the power source is DC or to the (Live) terminal if the power source is AC.

Terminal #	Description	Usage
2	PS1 Neutral/-	PS1 Neutral/- is connected to the negative (-) terminal if the power source is DC or to the (Neutral) terminal if the power source is AC.
3	Chassis Ground	Chassis Ground is connected to the Safety Ground terminal for AC inputs or the equipment ground bus for DC inputs. This terminal is connected to chassis ground internally. An additional chassis ground screw is also present that connects chassis ground to both power supply surge grounds via a removable jumper. For more information about the jumper, refer to Section 2.5.3, "Disabling Line-to-Ground Transient Protection" .
4	PS2 Neutral/-	PS2 Neutral/- is connected to the negative (-) terminal if the power source is DC or to the (Neutral) terminal if the power source is AC.
5	PS2 Live/+	PS2 Live/+ is connected to the positive (+) terminal if the power source is DC or to the (Live) terminal if the power source is AC.

Section 2.5.2

Power Supply Wiring

The following illustrates how to connect the RUGGEDCOM M969 to a single or dual power supplies.



NOTE

- For 100-240 VAC rated equipment, a 250 VAC appropriately rated circuit breaker must be installed.
- For 88-300VDC rated equipment, a 300VDC appropriately rated circuit breaker must be installed.
- A circuit breaker is not required for 12, 24 or 48 VDC rated power supplies.
- For dual power supplies, separate circuit breakers must be installed and separately identified.
- When equipped with two HI voltage power supplies, independent AC sources can be used to power the product for greater redundancy.

» Single HI AC Power Supply Wiring

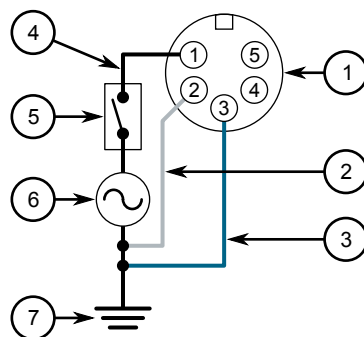

Figure 7: AC Power Supply Wiring Example (M23 Power Connector)

1. M23 Power Connector 2. Neutral 3. Safety 4. Line 5. 250 VAC Breaker 6. 110/230 VAC Power Source 7. Safety Earth

» Single Low DC Power Supply Wiring

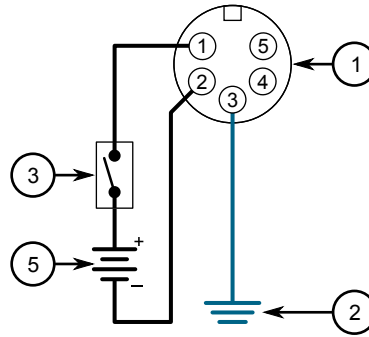

Figure 8: DC Power Supply Wiring Example (M23 Connector)

1. M23 Power Connector 2. Ground Bus 3. 300 VDC Breaker 4. DC Power Source

» Dual AC/DC Power Supply Wiring

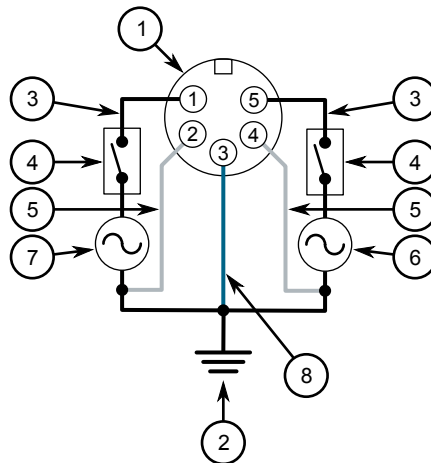

Figure 9: AC and AC Power Supply Wiring Example

1. M23 Power Connector 2. Ground Bus 3. Line 4. 250 VAC Breaker 5. Neutral 6. 110/230 VAC Power Source (PS2) 7. 110/230 VAC Power Source (PS1) 8. Safety

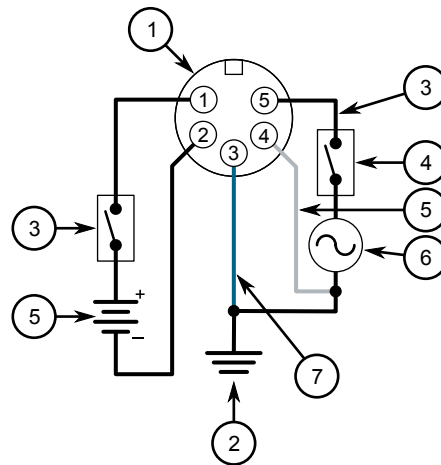

Figure 10: AC and DC Power Supply Wiring Example

1. M23 Power Connector 2. Ground Bus 3. Line 4. 250 VAC Breaker 5. 110/230 VAC Power Source (PS2) 6. Neutral 7. Safety
8. 300 VDC Breaker 9. DC Power Source (PS1)

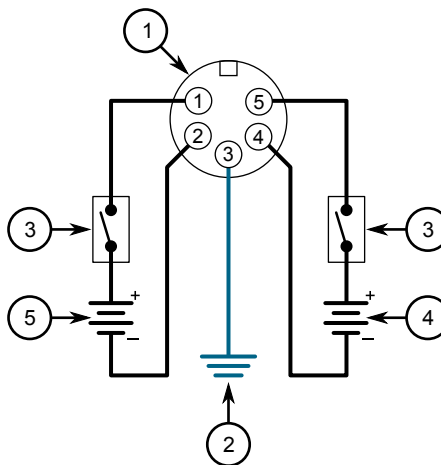

Figure 11: DC and DC Power Supply Wiring Example

1. M23 Power Connector 2. Ground Bus 3. 300 VDC Breaker 4. DC Power Source (PS2) 5. DC Power Source (PS1)

Section 2.5.3

Disabling Line-to-Ground Transient Protection

All line-to-ground transient energy is shunted to the Surge Ground terminal. In cases where users require the inputs to be isolated from ground, remove the ground braid between Surge and Chassis Ground. All line-to-ground transient protection circuitry will be disabled.

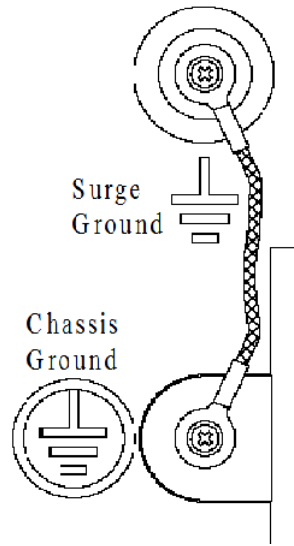

Figure 12: Surge Ground/Chassis Ground Connection

3 Device Management

This section describes how to connect to and manage the device.

CONTENTS

- [Section 3.1, "Connecting to the Device"](#)
- [Section 3.2, "Configuring the Device"](#)

Section 3.1

Connecting to the Device

The following describes the various methods for accessing the ROS console and Web interfaces on the device. For more detailed instructions, refer to the *ROS User Guide* for the RUGGEDCOM M969.

» RS-232 Console Port

Connect a PC or terminal directly to the RS-232 console port to access the boot-time control and ROS interfaces. The console port provides access to ROS's console and Web interfaces.



IMPORTANT!

The console port is intended to be used only as a temporary connection during initial configuration or troubleshooting.

Connection to the console port is made using an M12-to-DB9 console cable. The following is the pin-out for the console port:

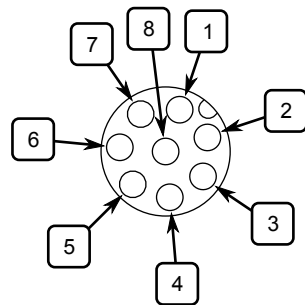

Figure 13: M12 Console Port Pin Configuration

Pin	Name	Description
1		Reserved (Do Not Connect)
2	RX	Receive Data (from DTE)
3	TX	Transmit Data (from DTE)
4		Reserved (Do Not Connect)
5	GND	Common Ground
6		Reserved (Do Not Connect)
7		Reserved (Do Not Connect)
8		Reserved (Do Not Connect)

» Communication Ports

Connect any of the available Ethernet ports on the device to a management switch and access the ROS console and Web interfaces via the device's IP address. The factory default IP address for the RUGGEDCOM M969 is <https://192.168.0.1>.

For more information about available ports, refer to [Chapter 4, Communication Ports](#).

Section 3.2

Configuring the Device

Once the device is installed and connected to the network, it must be configured. All configuration management is done via the RUGGEDCOM ROS interface. For more information about configuring the device, refer to the *RUGGEDCOM ROS User Guide* associated with the installed software release.

4 Communication Ports

The RUGGEDCOM M969 can be equipped with various types of communication ports to enhance its abilities and performance. To determine which ports are equipped on the device, refer to the factory data file available through ROS. For more information on how to access the factory data file, refer to the *ROS User Guide* for the RUGGEDCOM M969.

Each communication port type has a specific place in the RUGGEDCOM M969 chassis.

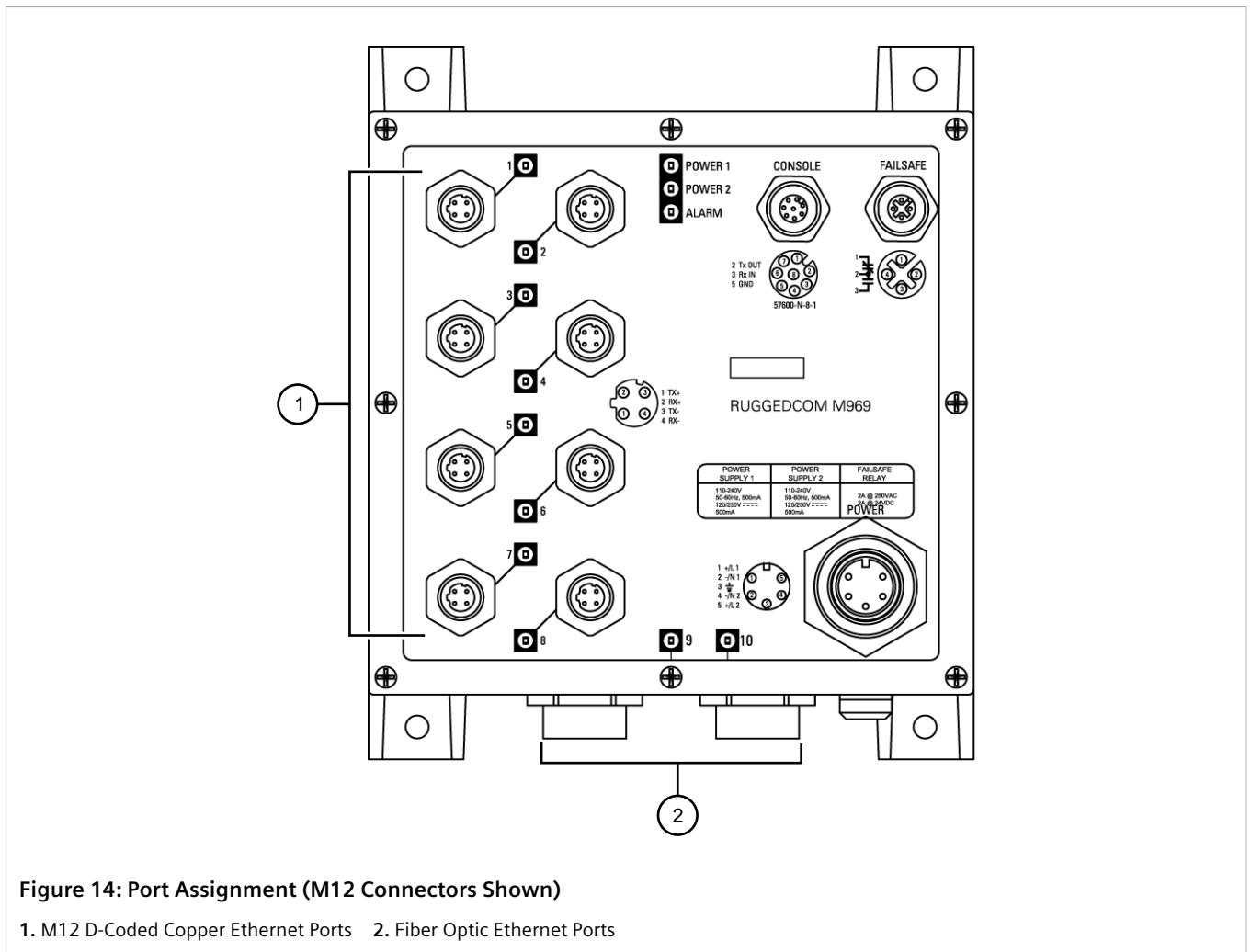

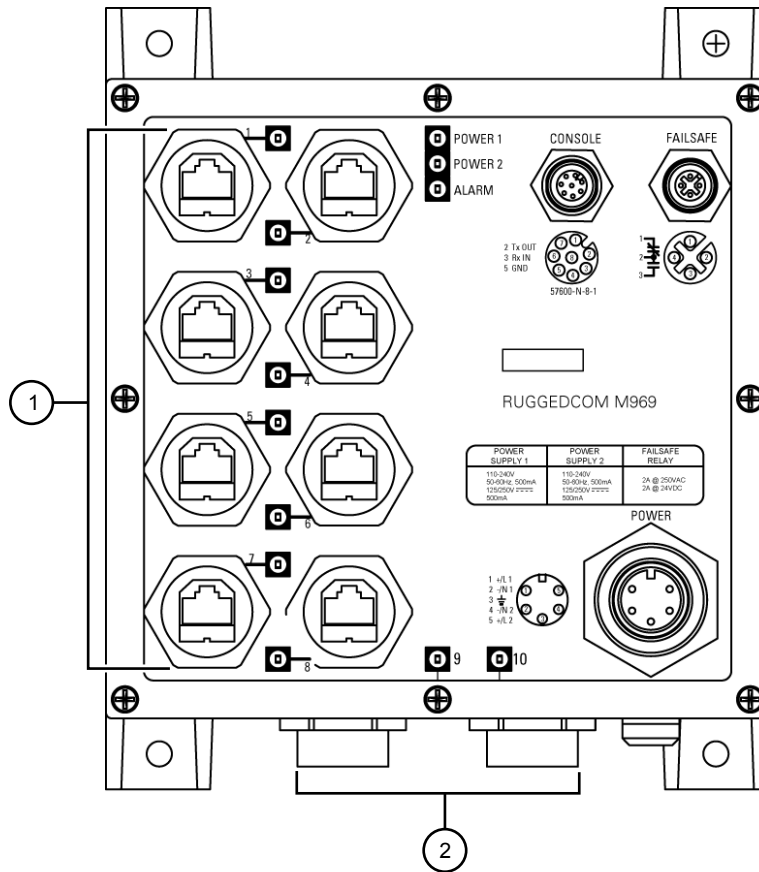

Figure 15: Port Assignment (RJ45 Connectors Shown)

1. RJ45 Copper Ethernet Ports 2. Fiber Optic Ethernet Ports

CONTENTS

- [Section 4.1, "Copper Ethernet Ports"](#)
- [Section 4.2, "Fiber Optic Ethernet Ports"](#)

Section 4.1

Copper Ethernet Ports

The RUGGEDCOM M969 supports eight 10/100Base-TX Ethernet ports that allow connection to standard Category 5 (CAT-5) unshielded twisted-pair (UTP) cables with RJ45 male connectors or M12 male connectors. The RJ45/M12 connectors are directly connected to chassis ground on the device and can accept CAT-5 shielded twisted-pair (STP) cables.



WARNING!

Electric shock hazard – risk of serious personal injury and/or equipment interference. If shielded cables are used, make sure the shielded cables do not form a ground loop via the shield wire and the RJ45/

M12 receptacles at either end. Ground loops can cause excessive noise and interference, but more importantly, create a potential shock hazard that can result in serious injury.

» Pin-Out (RJ45)

The following is the pin-out description for the RJ45 connectors:

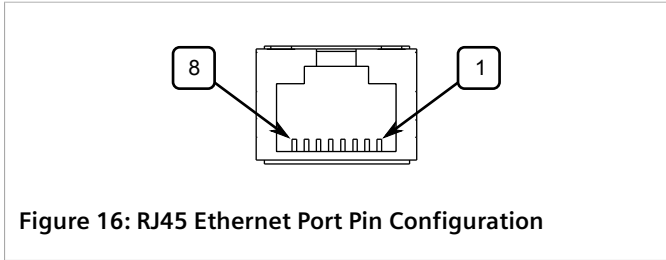

Figure 16: RJ45 Ethernet Port Pin Configuration

Pin	10/100Base-TX Signal	Description
1	RX+	Receive Data+
2	RX-	Receive Data-
3	TX+	Transmit Data+
4	Reserved (Do Not Connect)	
5	Reserved (Do Not Connect)	
6	TX-	Transmit Data-
7	Reserved (Do Not Connect)	
8	Reserved (Do Not Connect)	

» Pin-Out (M12)

The following is the pin-out description for the M12 connectors:

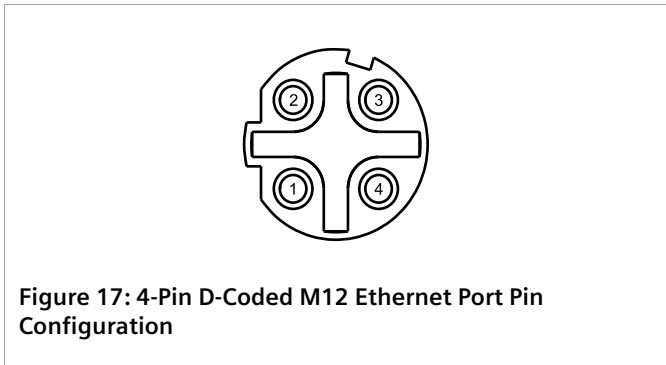

Figure 17: 4-Pin D-Coded M12 Ethernet Port Pin Configuration

Pin	10/100Base-Tx Signal
1	TX+
2	RX+
3	TX-
4	RX-

» Specifications

For specifications on the available copper Ethernet ports, refer to [Section 5.3, "Copper Ethernet Port Specifications"](#).

Section 4.2

Fiber Optic Ethernet Ports

Fiber optic Ethernet ports are available with an LC (Lucent Connector) connector. Make sure the Transmit (Tx) and Receive (Rx) connections of each port are properly connected and matched to establish a proper link.

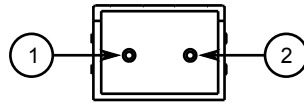

Figure 18: LC Port

1. Tx Connector 2. Rx Connector

For specifications on the available fiber optic Ethernet ports, refer to [Section 5.4, "Fiber Optic Ethernet Port Specifications"](#).

5 Technical Specifications

This section details the specifications and operating conditions of the device.

CONTENTS

- [Section 5.1, "Power Supply Specifications"](#)
- [Section 5.2, "Failsafe Alarm Relay Specifications"](#)
- [Section 5.3, "Copper Ethernet Port Specifications"](#)
- [Section 5.4, "Fiber Optic Ethernet Port Specifications"](#)
- [Section 5.5, "Operating Environment"](#)
- [Section 5.6, "Mechanical Specifications"](#)
- [Section 5.7, "Dimension Drawings"](#)

Section 5.1

Power Supply Specifications

Power Supply Type	Minimum Input	Maximum Input	Internal Fuse Rating	Isolation	Maximum Power Consumption
12–24 VDC	10 VDC	36 VDC	3.15A (T) ^a	1.5 kVDC	10 W
24 VDC	18 VDC	36 VDC			
48 VDC	36 VDC	72 VDC			
HI (125/250 VDC) ^b	88 VDC	300 VDC		4 kVAC	
HI (110/230 VAC) ^b	85 VAC	265 VAC		5.5 kVDC	

^a (T) denotes time-delay fuse.

^b This is the same power supply for both AC and DC.

Section 5.2

Failsafe Alarm Relay Specifications

Maximum Switching Voltage	Rated Switching Current	Isolation
30 VDC	2 A, 60 W	1500 V _{rms} for 1 minute
125 VDC	0.24 A, 30 W	
125 VAC	0.5 A, 62.5 W	

Maximum Switching Voltage	Rated Switching Current	Isolation
220 VDC	0.24 A, 60 W	
250 VAC	0.25 A, 62.5 W	

Section 5.3

Copper Ethernet Port Specifications

Data Port	10/100 Mbps
Media	CAT-5 UTP or STP
Distance	100 m (328 ft)
Connector Type	RJ45 or M12

Section 5.4

Fiber Optic Ethernet Port Specifications

The following details the specifications for fiber Ethernet ports that can be ordered with the RUGGEDCOM M969.

» Fast Ethernet Optical Specifications

Mode	Connector	Cable Type (µm)	Tx λ (nm) ^c	Tx (dBm)		Rx Sensitivity (dBm)	Rx Saturation (dBm)	Typical Distance (km)	Power Budget (dB)
				Min	Max				
SM	LC	9/125	1300	-15	-8	-32	-3	20	17
SM	LC	9/125	1300	-5	0	-35	3	50	30
SM	LC	9/125	1300	0	5	-37	0	90	37
MM	LC	50/125	850	-22.5	-14	-31	-14	2	8.5

^c Typical.

» Gigabit Ethernet Optical Specifications



NOTE

- All cabling is duplex type unless otherwise specified.
- Maximum segment length is greatly dependent on factors such as fiber quality, and the number of patches and splices. Consult a Siemens sales associate when determining maximum segment distances.
- All optical power numbers are listed as dBm averages. To convert from average to peak, add 3 dBm. To convert from peak to average, subtract 3 dBm.

Mode	Connector	Cable Type (µm)	Tx λ (nm) ^d	Tx (dBm)		Rx Sensitivity (dBm)	Rx Saturation (dBm)	Typical Distance (km)	Power Budget (dB)
				Min	Max				
MM	LC	50/125	850	-9.5	-4	-20	0	0.5	14
		62.5/125							
SM	LC	8/125	1310	-9.5	-3	-22	-3	10	17
		9/125							
SM	LC	8/125	1310	-7	3	-26	-3	25	19
		9/125							

^d Typical.

Section 5.5

Operating Environment

The RUGGEDCOM M969 is rated to operate under the following environmental conditions.

Ambient Operating Temperature^e	-40 to 85° C (-40 to 185° F) ^f
Ambient Storage Temperature	-40 to 85° C (-40 to 185° F)
Ambient Relative Humidity^g	5% to 95%
Maximum Altitude^h	15240 m (50000 ft)

^e Measured from a 30 cm (12 in) radius surrounding the center of the RUGGEDCOM M969 enclosure.

^f Reduced to -40 to 80 °C (-40 to 76 °F) when equipped with a 100Base-FX, single-mode, 1300 nm, long-reach 90 km port(s).

^g Non-condensing

^h Over temperature range of -40 to 85 °C (-40 to 185 °F)

Section 5.6

Mechanical Specifications

Weight	2.86 kg (6.3 lb)
Ingress Protection	IP67
Enclosure	Cast Aluminum

Section 5.7

Dimension Drawings



NOTE

All dimensions are in inches, unless otherwise stated.

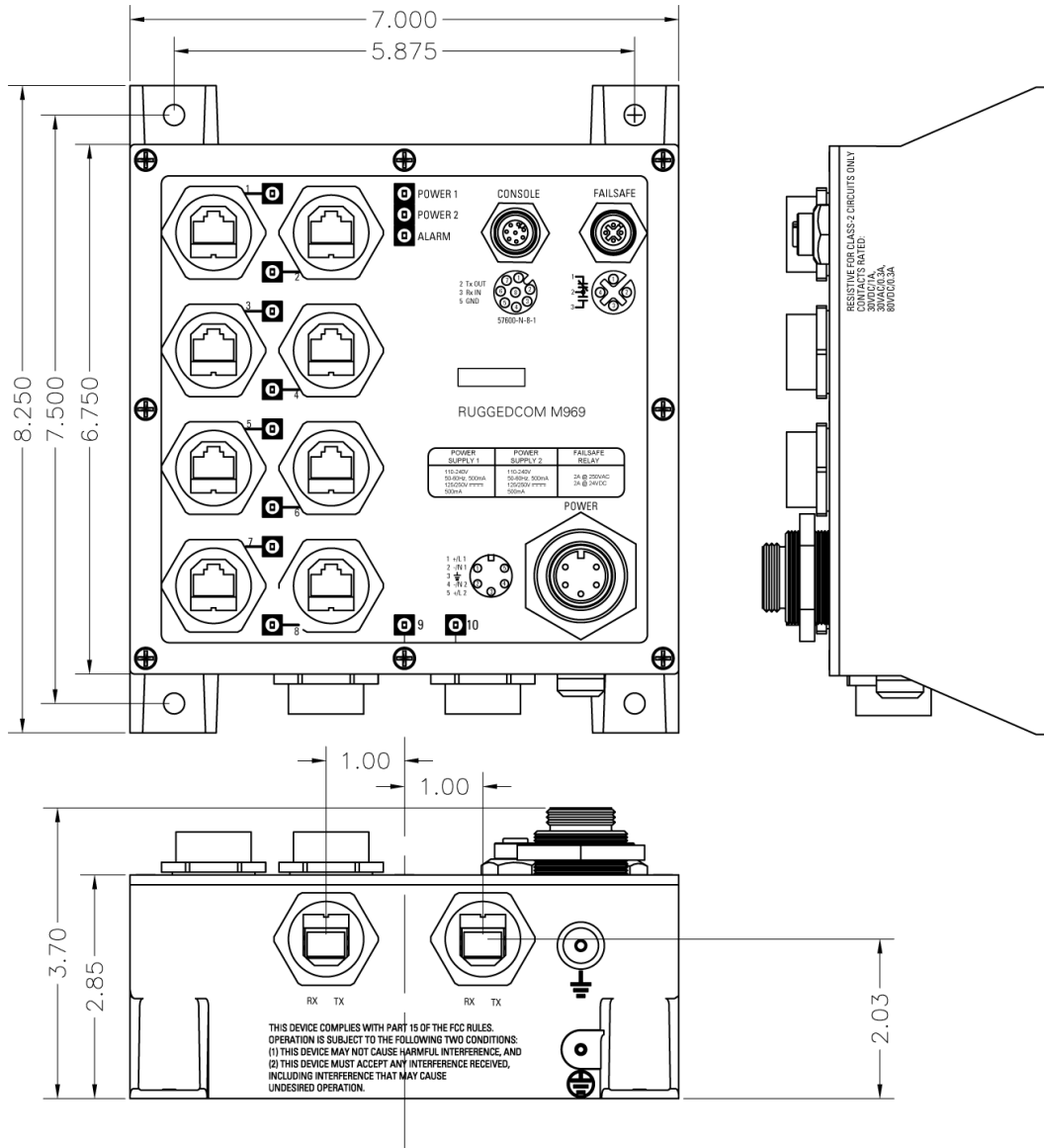

Figure 19: 8 RJ45 IP67 Ethernet Ports and M23 Power

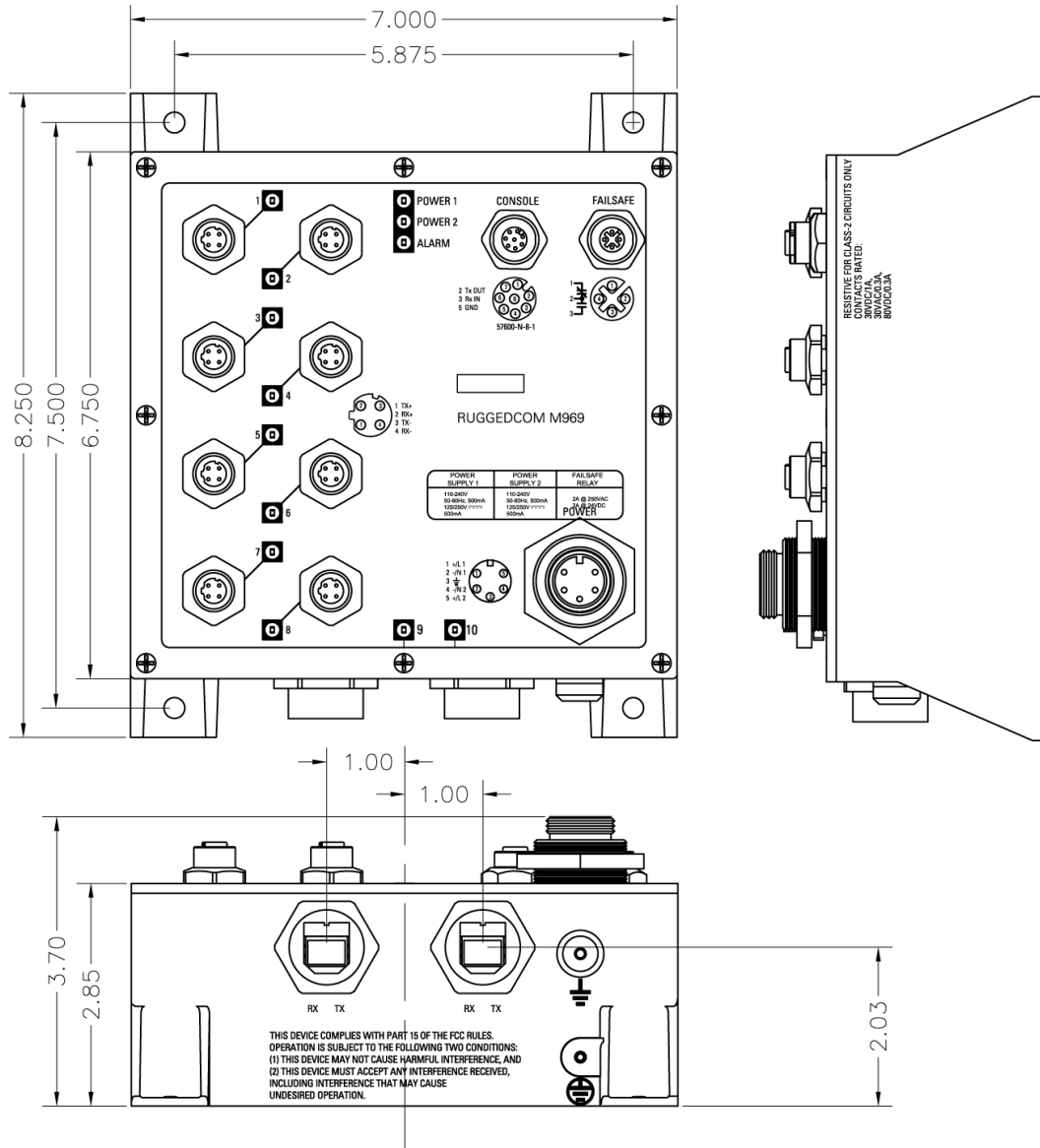

Figure 20: 8 M12 D-Code Ethernet Ports and M23 Power

6 Accessories

This chapter details the various accessories available for the RUGGEDCOM M969.

CONTENTS

- [Section 6.1, "Power \(1/unit\)"](#)
- [Section 6.2, "Console \(1/unit\)"](#)
- [Section 6.3, "Failsafe \(1/unit\)"](#)
- [Section 6.4, "Ethernet \(8/unit\)"](#)
- [Section 6.5, "LC Fiber Optic \(2/unit\)"](#)

Section 6.1

Power (1/unit)

» M23 Power Mating Connector

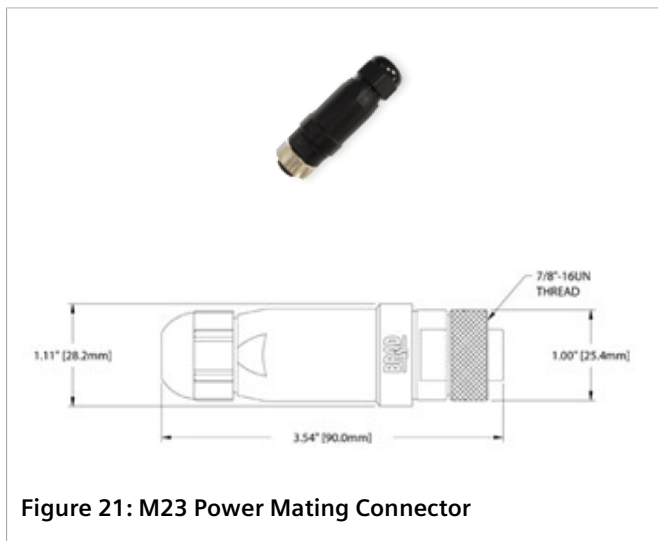

- **Description**
M23 5pin female connector, 600V, IP68 rated
- **Order Code**
99-60-0007
- **Cable Specifications**
3/18 AWG, jacket OD range 0.20" - 0.48"

» M23 Power Cable

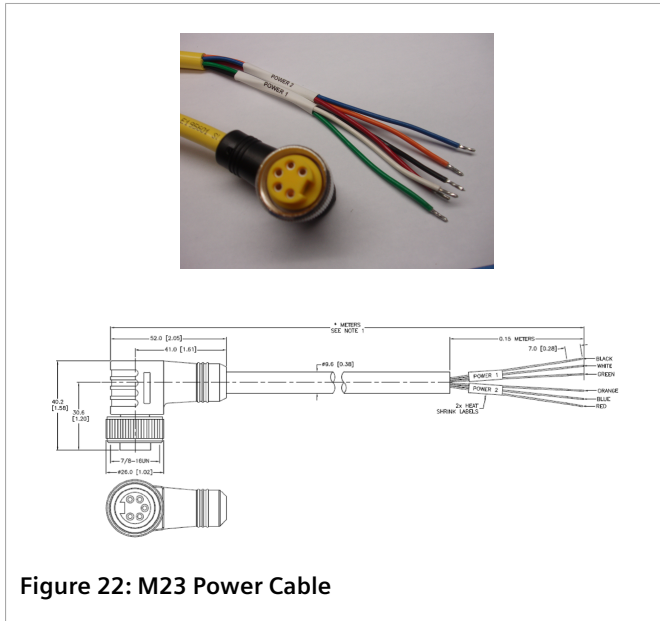

Figure 22: M23 Power Cable

- **Description**
Overmold R/A M23 plug to free end, 5m yellow PUR jacket, for dual power supply
- **Order Code**
99-43-0129-001
- **Cable Specifications**
Overmold R/A M23 plug to free end, 5 m

Section 6.2

Console (1/unit)

» M12 Console Port Mating Cable

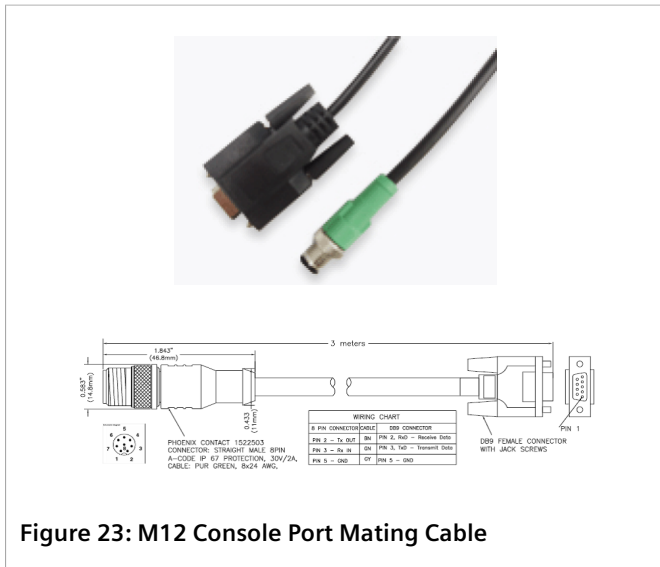
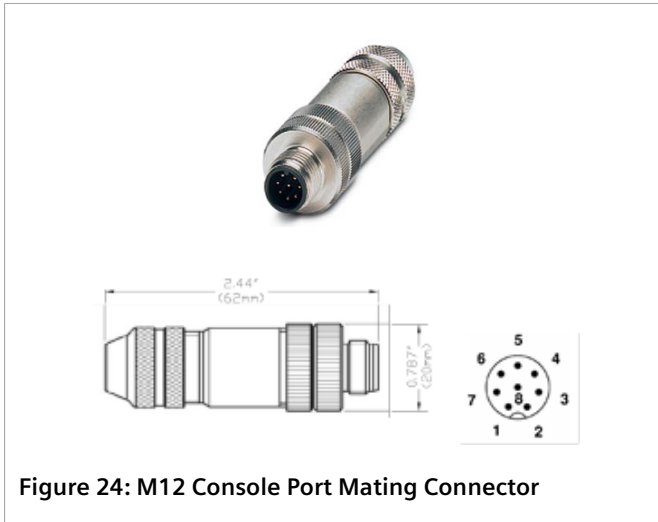

Figure 23: M12 Console Port Mating Cable

- **Description**
M12 8pin A-code male to DB9 female; unshielded, PUR jacket cable, 30V/4A, 3m
- **Order Code**
99-43-0023-001
- **Cable Specifications**
M12 8pin A-code male to free end, 3m

» M12 Console Port Mating Connector



- **Description**
M12-straight plug, 8 pole, A-coded, IP67 rated
- **Order Code**
99-60-0002

Section 6.3

Failsafe (1/unit)

» M12 FailSafe Port Mating Cable

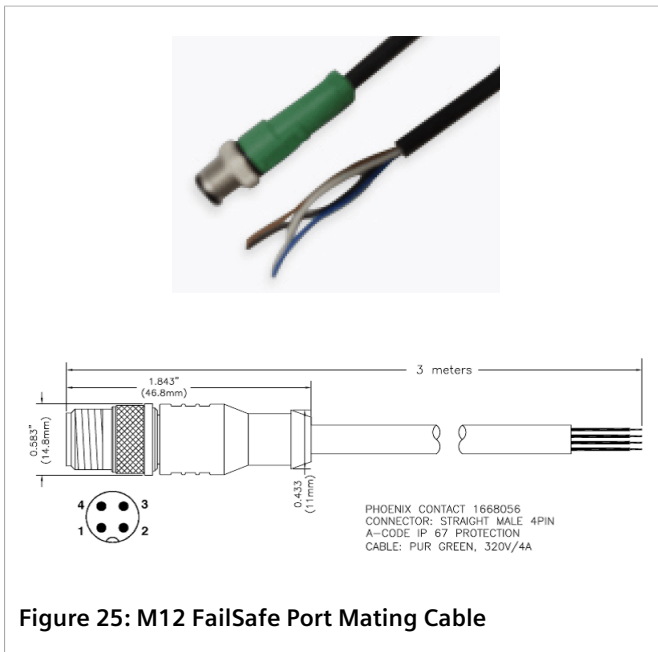

- **Description**
M12 4pole A-coded; unshielded, PUR Jacket cable, 3m
- **Order Code**
99-43-0024-001

» M12 FailSafe Port Mating Connector

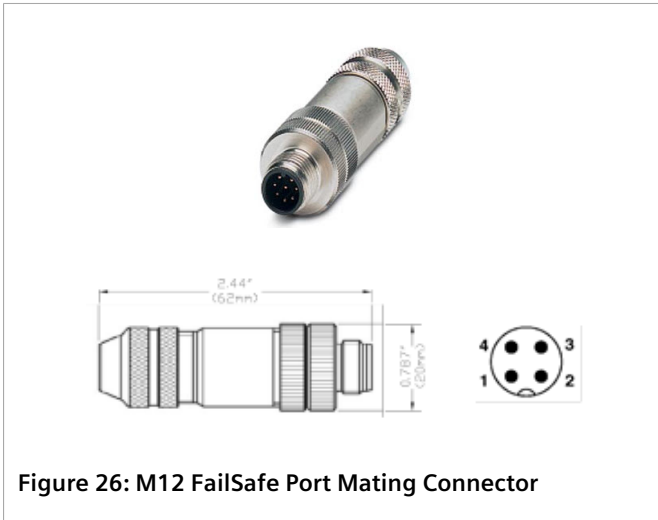

- **Description**
M12-straight plug, 4 pole, A-coded, IP67 rated
- **Order Code**
99-60-0009

Section 6.4

Ethernet (8/unit)

» M12 D-code Ethernet Port Mating Cable

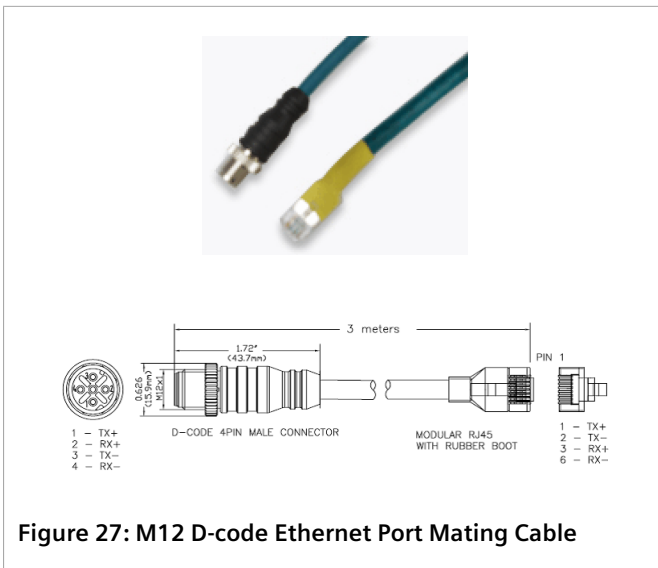

- **Description**
M12 D-code to RJ45; patch cable, 3meters
- **Order Code**
99-43-0040-001
- **Cable Specifications**
M12 D-code male 4 pin, CAT5e, 3m

» M12 D-code Ethernet Port Mating Connector

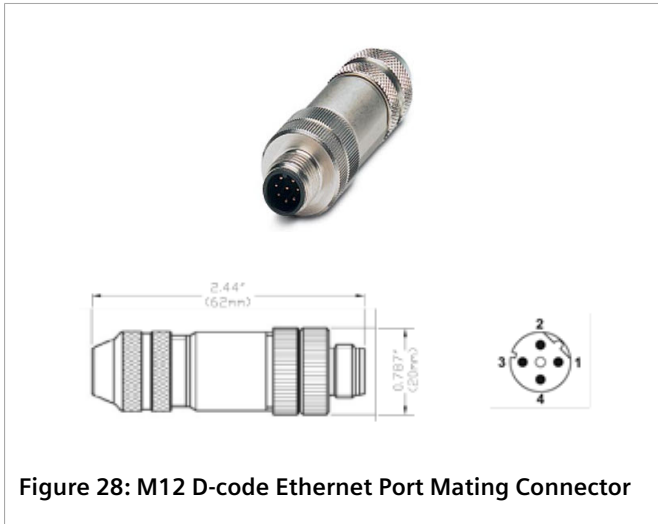

- **Description**
M12-straight plug, 4 pole, D-coded, IP67 rated
- **Order Code**
99-60-0008

» M12 D-Code Ethernet Port Mating Cable

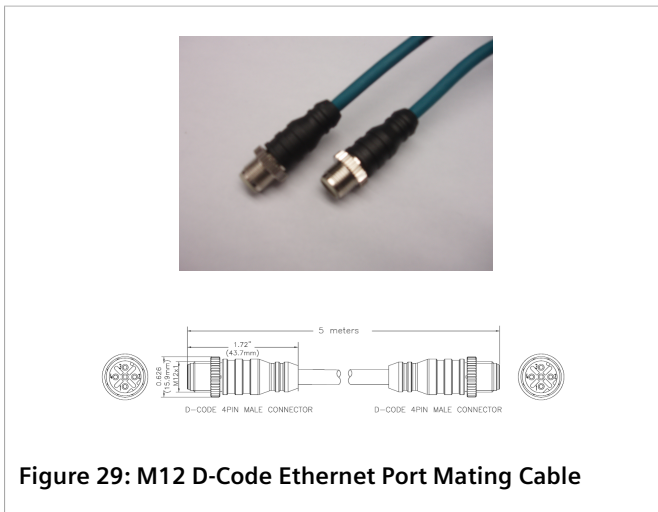

- **Description**
M12 male D-code to male D-code; shielded PUR jacket patch cable, 5 meters
- **Order Code**
99-43-0041-001
- **Cable Specifications**
M12 male 4 pin, CAT 5e, 5m

» IP67 Metal RJ45 Ethernet Port Mating Cable

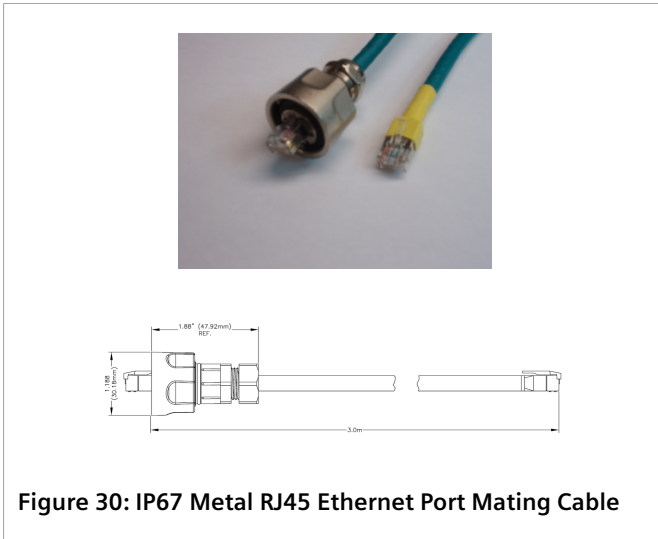

- **Description**
IP67 Metal RJ45 plug to RJ45, CAT5e shielded patch cable, 3m
- **Order Code**
99-43-0182-001

» IP67 Metal RJ45 Ethernet Port Mating Connector

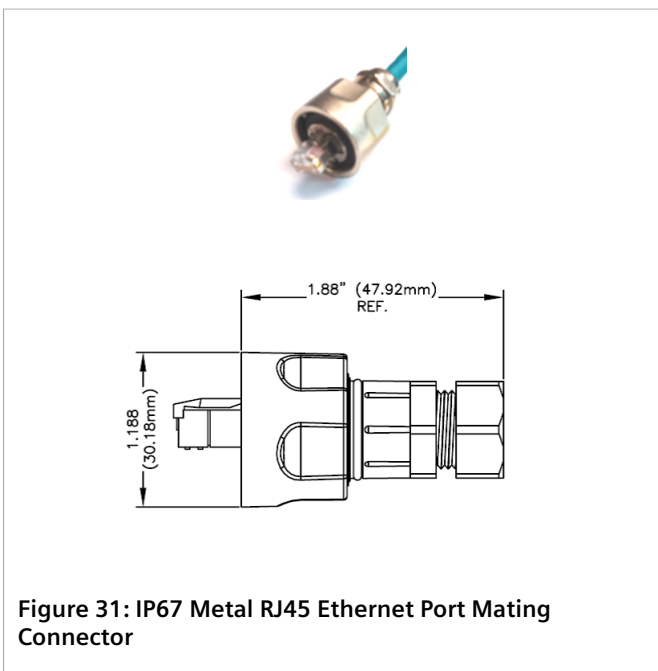

- **Description**
IP67 Metal RJ45 plug, field attachable
- **Order Code**
99-60-0010

» IP67 Metal RJ45 Ethernet Port Mating Cable

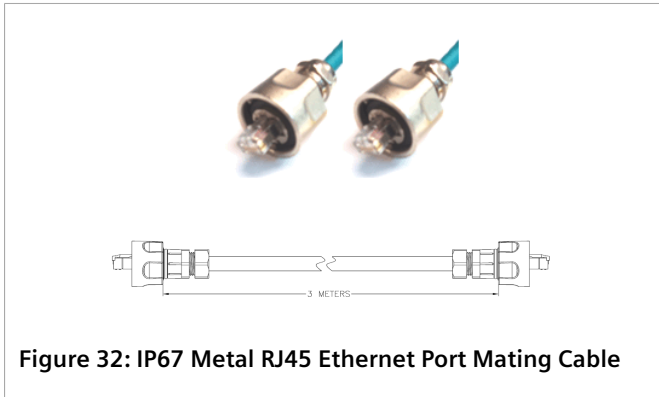

- **Description**
IP67 Metal RJ45 plug on both ends; Category 5e shielded patch cable, 3m
- **Order Code**
99-43-0039-001

Section 6.5

LC Fiber Optic (2/unit)

» LC Port Mating Connector

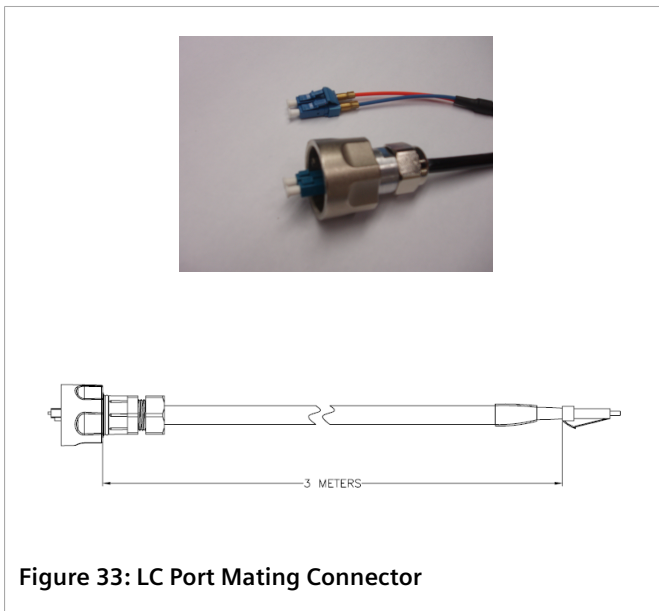

- **Description**
Cable Multimode Metal IP67LC to LC, Multimode fiber cable 3meters, IP67 rated
- **Order Code**
99-43-0057-001

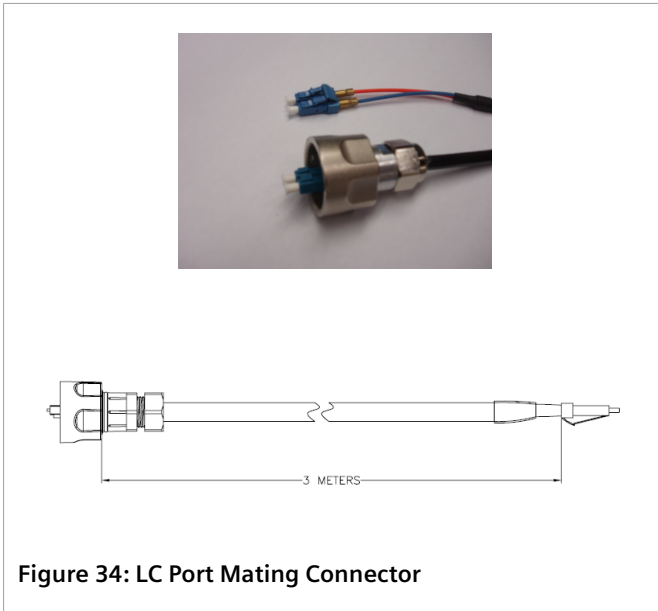

- **Description**
Cable Singlemode Metal IP67 LC to LC, Singlemode fiber cable 3 meters, IP67 rated
- **Order Code**
99-43-0055-001

» LC Port Mating Connector

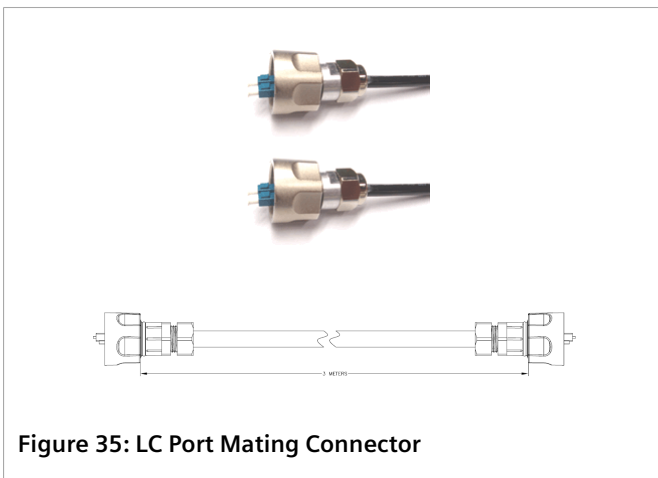

- **Description**
Cable Multimode Metal IP67 LC to Metal IP67 LC, Multimode fiber cable 3meters, IP67 rated
- **Order Code**
99-43-0047-001

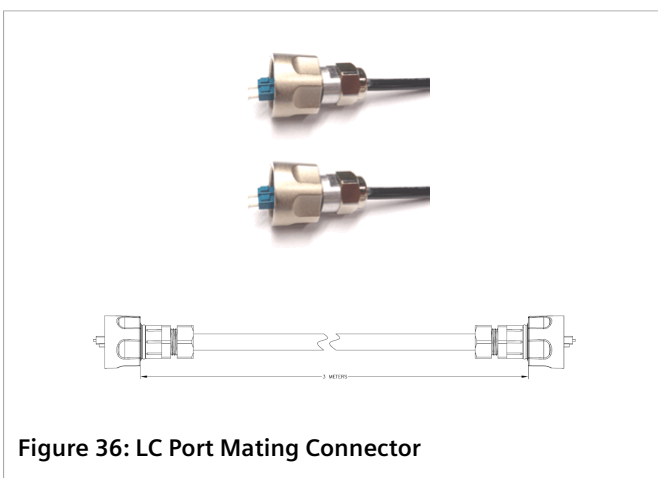

- **Description**
Cable Singlemode Metal IP67 LC to Metal IP67 LC, Singlemode fiber cable 3 meters, IP67 rated
- **Order Code**
99-43-0053-001

» LC, RJ45 Port Cap



- **Description**
RJ45 outlet cap IP67, Metal
- **Order Code**
99-60-0011

7 Certification

The RUGGEDCOM M969 device has been thoroughly tested to guarantee its conformance with recognized standards and has received approval from recognized regulatory agencies.

CONTENTS

- [Section 7.1, "Approvals"](#)
- [Section 7.2, "MIL-STD Test Specifications"](#)
- [Section 7.3, "EMC and Environmental Type Tests"](#)

Section 7.1

Approvals

This section details the standards to which the RUGGEDCOM M969 complies.

CONTENTS

- [Section 7.1.1, "CSA"](#)
- [Section 7.1.2, "European Commission \(EC\)"](#)
- [Section 7.1.3, "FCC"](#)
- [Section 7.1.4, "FDA/CDRH"](#)
- [Section 7.1.5, "ISED"](#)
- [Section 7.1.6, "ACMA"](#)
- [Section 7.1.7, "RoHS"](#)
- [Section 7.1.8, "Other Approvals"](#)

Section 7.1.1

CSA

This device meets the requirements of the following Canadian Standards Association (CSA) standards under certificate 16.70065161:

- **CAN/CSA-C22.2 No. 60950-1**
Information Technology Equipment – Safety – Part 1: General Requirements (Bi-National Standard, with UL 60950-1)
- **UL 60950-1**
Information Technology Equipment – Safety Part 1: General Requirements

Section 7.1.2

European Commission (EC)

This device is declared by Siemens Canada Ltd to comply with essential requirements and other relevant provisions of the following EC directives:

- **EN 60950-1**
Information Technology Equipment – Safety – Part 1: General Requirements
- **EN 61000-6-2**
Electromagnetic Compatibility (EMC) – Part 6-2: Generic Standards – Immunity for Industrial Environments
- **EN 60825-1**
Safety of Laser Products – Equipment Classification and Requirements
- **EN 50581**
Technical Documentation for the Assessment of Electrical and Electronic Products with Respect to the Restriction of Hazardous Substances
- **EN 55022**
Information Technology Equipment – Radio Disturbance Characteristics – Limits and Methods of Measurement

The device is marked with a CE marking and can be used throughout the European community.



A copy of the CE Declaration of Conformity is available from Siemens Canada Ltd. For contact information, refer to [“Contacting Siemens”](#).

Section 7.1.3

FCC

This device has been tested and found to comply with the limits for a Class A digital device, pursuant to Part 15 of the FCC Rules. These limits are designed to provide reasonable protection against harmful interference when the equipment is operated in a commercial environment.

This device generates, uses and can radiate radio frequency energy and, if not installed and used in accordance with the instruction manual, may cause harmful interference to radio communications. Operation of this equipment in a residential area is likely to cause harmful interference in which case the user will be required to correct the interference on his own expense.

Section 7.1.4

FDA/CDRH

This device meets the requirements of the following U.S. Food and Drug Administration (FDA) standard:

- Title 21 Code of Federal Regulations (CFR) – Chapter I – Sub-chapter J – Radiological Health

Section 7.1.5

ISED

This device is declared by Siemens Canada Ltd to meet the requirements of the following ISED (Innovation Science and Economic Development Canada) standard:

- CAN ICES-3 (A)/NMB-3 (A)

This device further complies with IC RSS-210 and is approved under the ID 4997A-VG5RW80G.

Section 7.1.6

ACMA

This device meets the requirements of the following Australian Communications and Media Authority (ACMA) standards under certificate ABN 98 004 347 880:

- Radiocommunications (Compliance Labelling – Devices) Notice 2014 made under Section 182 of the Radiocommunications Act 1992
- Radiocommunications Labelling (Electromagnetic Compatibility) Notice 2008 made under Section 182 of the Radiocommunications Act 1992
- Radiocommunications (Compliance Labelling – Electromagnetic Radiation) Notice 2003 made under Section 182 of the Radiocommunications Act 1992
- Telecommunications Labelling (Customer Equipment and Customer Cabling) Notice 2001 made under Section 407 of the Telecommunication Act 1997

The device is marked with an RCM symbol to indicate compliance when sold in the Australian region.



A copy of the Declaration of Conformity is available via Siemens Industry Online Support at <https://support.industry.siemens.com/cs/ww/en/view/89855782>.

Section 7.1.7

RoHS

This device is declared by Siemens Canada Ltd to meet the requirements of the following RoHS (Restriction of Hazardous Substances) directives for the restricted use of certain hazardous substances in electrical and electronic equipment:

- **China RoHS 2**
Administrative Measure on the Control of Pollution Caused by Electronic Information Products

A copy of the Material Declaration is available online at <https://support.industry.siemens.com/cs/ww/en/view/109738831>.

Section 7.1.8

Other Approvals

This device meets the requirements of the following additional standards:

- **IEEE 1613**
IEEE Standard Environmental and Testing Requirements for Communications Networking Devices in Electric Power Substations
- **IEC 61000-6-2**
Electromagnetic Compatibility (EMC) – Part 6-2: Generic Standards – Immunity for Industrial Environments
- **IEC 61850-3**
Communication Networks and Systems in Substations – Part 3: General Requirements
- **NEMA TS-2**
Traffic Controller Assemblies with NTCIP Requirements
- **MIL-S-901D**
MIL-S-901D – Military Specification – Shock Tests. H.I. (High-Impact) Shipboard Machinery, Equipment, and Systems, Requirements For

Section 7.2

MIL-STD Test Specifications

Test	Description	
MIL-STD-167	Vibration Navy MIL-STD –167-1 Type I	
MIL-STD-461E	CE101	
	CE102	DC 28V
		AC 115V
	RE101	
	RE102	RE102-1, Surface Ship Applications
		RE102-2, Submarine Applications, Internal
		RE102-3, AirCRAFT and Space Applications
		RE102-4, Ground Applications
	CS101	
	CS114	
	CS115	
	CS116	
	RS101	
	RS103	
MIL-STD-810F	Low Pressure Altitude Method 500.4 Procedure I Storage	
	Low Pressure Altitude Method 500.4 Procedure II Operational	
	High Temperature Method 501.4 Procedure I Storage	

Test	Description
	High Temperature Method 501.4 Procedure II Operational
	Low Temperature Method 502.4 Procedure I Storage
	Low Temperature Method 502.4 Procedure II Operational
	Temperature Shock Method 503.4 Procedure I Storage
	Acceleration Method 513.5 Procedure II
	Salt Fog Method 509.4 Procedure I
	Vibration Method 514.5
MIL-STD 901D	High Impact Shock Test
MIL-STD-1275B	Power Quality
MIL-STD-1399	DC Magnetic Field Testing Section 070 Part 1

Section 7.3

EMC and Environmental Type Tests

The RUGGEDCOM M969 has passed the following EMC and environmental tests.

» IEC 61850-3 Type Tests

Test	Description		Test Levels	Severity Levels
IEC 61000-4-2	ESD	Enclosure Contact	± 8 kV	4
		Enclosure Air	± 15 kV	4
IEC 61000-4-3	Radiated RFI	Enclosure ports	20 V/m	x
IEC 61000-4-4	Burst (Fast Transient)	Signal ports	± 4 kV @ 2.5 kHz	x
		DC Power ports	± 4 kV	4
		AC Power ports	± 4 kV	4
		Earth ground ports	± 4 kV	4
IEC 61000-4-5	Surge	Signal ports	± 4 kV line-to-earth, ± 2 kV line-to-line	4
		DC Power ports	± 2 kV line-to-earth, ± 1 kV line-to-line	3
		AC Power ports	± 4 kV line-to-earth, ± 2 kV line-to-line	4
IEC 61000-4-6	Induced (Conducted) RFI	Signal ports	10V	3
		DC Power ports	10 V	3
		AC Power ports	10 V	3
		Earth ground ports	10 V	3
IEC 61000-4-8	Magnetic Field	Enclosure ports	40 A/m continuous, 1000 A/m for 1 s	—

Test	Description		Test Levels	Severity Levels
IEC 61000-4-29	Voltage Dips & Interrupts	DC Power ports	30% for 0.1 s, 60% for 0.1 s, 100% for 0.05 s	—
		AC Power ports	30% for 1 period, 60% for 50 periods	—
IEC 61000-4-11			100% for 5 periods, 100% for 50 periods ²	—
IEC 61000-4-12	Damped Oscillatory	Signal ports	2.5 kV common, 1 kV differential mode @ 1MHz	3
		DC Power ports	2.5 kV common, 1 kV differential mode @ 1MHz	3
		AC Power ports	2.5 kV common, 1 kV differential mode @ 1MHz	3
IEC 61000-4-16	Mains Frequency Voltage	Signal ports	30 V Continuous, 300 V for 1 s	4
		DC Power ports	30 V Continuous, 300 V for 1 s	4
IEC 61000-4-17	Ripple on DC Power Supply	DC Power ports	10%	3
IEC 60255-5	Dielectric Strength	Signal ports	2 kV (Fail-Safe Relay output)	—
		DC Power ports	1.5 kV	—
		AC Power ports	2 kV	—
IEC 60255-5	HV Impulse	Signal ports	5 kV (Fail-Safe Relay output)	—
		DC Power ports	5 kV	—
		AC Power ports	5 kV	—

» IEEE 1613 Type Tests



NOTE

- If the unit contains copper ports, the IEEE 1613 conformance is Class 1 (during disturbance, errors may occur but recovery is automatic).
- If the unit contains all fiber ports, the IEEE 1613 conformance is Class 2 (during disturbance, no errors will occur).

Description		Test Levels
ESD	Enclosure Contact	± 8 kV
	Enclosure Air	± 15 kV
Radiated RFI	Enclosure ports	35 V/m
Fast Transient	Signal ports	± 4 kV @ 2.5 kHz
	DC Power ports	± 4 kV
	AC Power ports	± 4 kV
	Earth ground ports	± 4 kV
Oscillatory	Signal ports	2.5 kV common mode @ 1MHz
	DC Power ports	2.5 kV common & differential mode @ 1MHz
	AC Power ports	2.5 kV common & differential mode @ 1MHz

Description		Test Levels
HV Impulse	Signal ports	5 kV (Failsafe Relay)
	DC Power ports	5 kV
	AC Power ports	5 kV
Dielectric Strength	Signal ports	2 kV
	DC Power ports	1.5 kV
	AC Power ports	2 kV

» Environmental Type Tests



NOTE

Class 2 refers to Measuring relays and protection equipment for which a very high security margin is required or where the vibration levels are very high, (e.g. shipboard application and for severe transportation conditions).

Test	Description		Test Levels	Severity Levels
IEC 60068-2-1	Cold Temperature	Test Ad	-40 °C (40 °F), 16 Hours	—
IEC 60068-2-2	Dry Heat	Test Bd	85 °C (185 °F), 16 Hours	—
IEC 60068-2-30	Humidity (Damp Heat, Cyclic)	Test Db	95% (non-condensing), 55 °C (131 °F), 6 cycles	—
IEC 60255-21-1	Vibration		2g @ 10-150 Hz	Class 2
IEC 60255-21-2	Shock		30 g @ 11 ms	Class 2
IEC 60529 (IPx6)	Ingress Protection	Water Jet	100 l/m @ 2.5 m as per 14.2.6	—
IEC 60529 (IPx7)	Ingress Protection	Water Submersion	30 min @ 1 m as per 14.2.7	—
IEC 60529 (IP6x)	Ingress Protection	Dust Talcum	2 kg/m ³ for 8 h as per 13.4	Cat. 1 & 2

