

Siemens  
EcoTech



Circuit breaker size S2 for motor protection, CLASS 10 A-release 62...73 A N-release 949 A screw terminal increased switching capacity with transverse auxiliary switches 1 NO+1 NC



product brand name	SIRIUS
product designation	Circuit breaker
design of the product	For motor protection
product type designation	3RV2
<b>General technical data</b>	
size of the circuit-breaker	S2
size of contactor can be combined company-specific	S2
product extension auxiliary switch	Yes
power loss [W] for rated value of the current	
• at AC in hot operating state	29.5 W
• at AC in hot operating state per pole	9.8 W
insulation voltage with degree of pollution 3 at AC rated value	690 V
surge voltage resistance rated value	6 kV
shock resistance according to IEC 60068-2-27	25g / 11 ms Sinus
mechanical service life (operating cycles)	
• of the main contacts typical	20 000
• of auxiliary contacts typical	20 000
electrical endurance (operating cycles) typical	20 000
reference code according to IEC 81346-2	Q
Substance Prohibitance (Date)	03/01/2017
SVHC substance name	Lead - 7439-92-1
Weight	1.183 kg
<b>Ambient conditions</b>	
installation altitude at height above sea level maximum	2 000 m
ambient temperature	
• during operation	-20 ... +60 °C
• during storage	-50 ... +80 °C
• during transport	-50 ... +80 °C
relative humidity during operation	10 ... 95 %
<b>Environmental footprint</b>	
Global Warming Potential [CO2 eq] total	239.877 kg
Global Warming Potential [CO2 eq] during manufacturing	12.8 kg
global warming potential [CO2 eq] during sales	0.477 kg
Global Warming Potential [CO2 eq] during operation	230 kg
Global Warming Potential [CO2 eq] after end of life	-3.4 kg
Siemens Eco Profile (SEP)	Siemens EcoTech
<b>Main circuit</b>	

<b>number of poles for main current circuit</b>	3
<b>adjustable current response value current of the current-dependent overload release</b>	62 ... 73 A
<b>operating voltage</b>	
• rated value	20 ... 690 V
• at AC-3 rated value maximum	690 V
<b>operating frequency rated value</b>	50 ... 60 Hz
<b>operational current rated value</b>	73 A
<b>operational current</b>	
• at AC-3 at 400 V rated value	73 A
<b>operating power</b>	
• at AC-3	
— at 230 V rated value	22 kW
— at 400 V rated value	37 kW
— at 500 V rated value	45 kW
— at 690 V rated value	55 kW
<b>operating frequency</b>	
• at AC-3 maximum	15 1/h
<b>Auxiliary circuit</b>	
<b>design of the auxiliary switch</b>	transverse
<b>number of NC contacts for auxiliary contacts</b>	1
<b>number of NO contacts for auxiliary contacts</b>	1
<b>operational current of auxiliary contacts at AC-15</b>	
• at 24 V	2 A
• at 230 V	0.5 A
<b>operational current of auxiliary contacts at DC-13</b>	
• at 24 V	1 A
• at 60 V	0.15 A
• at 110 V	0 A
• at 125 V	0 A
• at 220 V	0 A
<b>Protective and monitoring functions</b>	
<b>product function</b>	
• ground fault detection	No
• phase failure detection	Yes
<b>trip class</b>	CLASS 10
<b>design of the overload release</b>	thermal
<b>maximum short-circuit current breaking capacity (I<sub>cu</sub>)</b>	
• at AC at 240 V rated value	100 kA
• at AC at 400 V rated value	100 kA
• at AC at 500 V rated value	10 kA
• at AC at 690 V rated value	6 kA
<b>operating short-circuit current breaking capacity (I<sub>cs</sub>) at AC</b>	
• at 240 V rated value	100 kA
• at 400 V rated value	50 kA
• at 500 V rated value	8 kA
• at 690 V rated value	4 kA
response value current of instantaneous short-circuit trip unit	949 A
<b>UL/CSA ratings</b>	
<b>full-load current (FLA) for 3-phase AC motor</b>	
• at 480 V rated value	65 A
• at 600 V rated value	62 A
<b>yielded mechanical performance [hp]</b>	
• for 3-phase AC motor	
— at 200/208 V rated value	20 hp
— at 220/230 V rated value	25 hp
— at 460/480 V rated value	50 hp
— at 575/600 V rated value	60 hp
<b>contact rating of auxiliary contacts according to UL</b>	C300 / R300
<b>Short-circuit protection</b>	
<b>product function short circuit protection</b>	Yes

<b>design of the short-circuit trip</b>	magnetic
<b>design of the fuse link</b>	
<ul style="list-style-type: none"> <li>for short-circuit protection of the auxiliary switch required</li> </ul>	fuse gG: 10 A, miniature circuit breaker C 6 A (short-circuit current $I_k < 400$ A)
<b>design of the fuse link for IT network for short-circuit protection of the main circuit</b>	
<ul style="list-style-type: none"> <li>at 240 V</li> <li>at 400 V</li> <li>at 500 V</li> <li>at 690 V</li> </ul>	none required 160 125 100
<b>Installation/ mounting/ dimensions</b>	
<b>mounting position</b>	any
<b>fastening method</b>	screw and snap-on mounting onto 35 mm DIN rail according to DIN EN 60715
<b>height</b>	140 mm
<b>width</b>	55 mm
<b>depth</b>	149 mm
<b>required spacing</b>	
<ul style="list-style-type: none"> <li>with side-by-side mounting at the side</li> <li>for grounded parts at 400 V               <ul style="list-style-type: none"> <li>downwards</li> <li>upwards</li> <li>at the side</li> </ul> </li> <li>for live parts at 400 V               <ul style="list-style-type: none"> <li>downwards</li> <li>upwards</li> <li>at the side</li> </ul> </li> <li>for grounded parts at 500 V               <ul style="list-style-type: none"> <li>downwards</li> <li>upwards</li> <li>at the side</li> </ul> </li> <li>for live parts at 500 V               <ul style="list-style-type: none"> <li>downwards</li> <li>upwards</li> <li>at the side</li> </ul> </li> <li>for grounded parts at 690 V               <ul style="list-style-type: none"> <li>downwards</li> <li>upwards</li> <li>at the side</li> </ul> </li> <li>for live parts at 690 V               <ul style="list-style-type: none"> <li>downwards</li> <li>upwards</li> <li>at the side</li> </ul> </li> </ul>	0 mm  50 mm 50 mm 10 mm  50 mm 50 mm 10 mm  50 mm 50 mm 10 mm  50 mm 50 mm 10 mm  50 mm 50 mm 10 mm
<b>Connections/ Terminals</b>	
<b>type of electrical connection</b>	
<ul style="list-style-type: none"> <li>for main current circuit</li> <li>for auxiliary and control circuit</li> </ul>	screw-type terminals screw-type terminals
<b>arrangement of electrical connectors for main current circuit</b>	Top and bottom
<b>type of connectable conductor cross-sections</b>	
<ul style="list-style-type: none"> <li>for main contacts               <ul style="list-style-type: none"> <li>solid or stranded</li> <li>finely stranded with core end processing</li> </ul> </li> <li>for AWG cables for main contacts</li> </ul>	2x (1 ... 35 mm <sup>2</sup> ), 1x (1 ... 50 mm <sup>2</sup> ) 2x (1 ... 25 mm <sup>2</sup> ), 1x (1 ... 35 mm <sup>2</sup> ) 2x (18 ... 2), 1x (18 ... 1)
<b>type of connectable conductor cross-sections</b>	
<ul style="list-style-type: none"> <li>for auxiliary contacts               <ul style="list-style-type: none"> <li>solid or stranded</li> <li>finely stranded with core end processing</li> </ul> </li> <li>for AWG cables for auxiliary contacts</li> </ul>	2x (0.5 ... 1.5 mm <sup>2</sup> ), 2x (0.75 ... 2.5 mm <sup>2</sup> ) 2x (0.5 ... 1.5 mm <sup>2</sup> ), 2x (0.75 ... 2.5 mm <sup>2</sup> ) 2x (20 ... 16), 2x (18 ... 14)
<b>tightening torque</b>	
<ul style="list-style-type: none"> <li>for main contacts with screw-type terminals</li> <li>for auxiliary contacts with screw-type terminals</li> </ul>	3 ... 4.5 N·m 0.8 ... 1.2 N·m
<b>design of screwdriver shaft</b>	Diameter 5 to 6 mm

size of the screwdriver tip	Pozidriv size 2
design of the thread of the connection screw	
<ul style="list-style-type: none"> <li>for main contacts</li> </ul>	M6
<ul style="list-style-type: none"> <li>of the auxiliary and control contacts</li> </ul>	M3

**Safety related data**

product function suitable for safety function	Yes
suitability for use	
<ul style="list-style-type: none"> <li>safety-related switching on</li> </ul>	No
<ul style="list-style-type: none"> <li>safety-related switching OFF</li> </ul>	Yes
service life maximum	10 a
test wear-related service life necessary	Yes
proportion of dangerous failures	
<ul style="list-style-type: none"> <li>with low demand rate according to SN 31920</li> </ul>	40 %
<ul style="list-style-type: none"> <li>with high demand rate according to SN 31920</li> </ul>	50 %
B10 value with high demand rate according to SN 31920	5 000
failure rate [FIT] with low demand rate according to SN 31920	50 FIT

ISO 13849

device type according to ISO 13849-1	3
overdimensioning according to ISO 13849-2 necessary	Yes

IEC 61508

safety device type according to IEC 61508-2	Type A
T1 value	
<ul style="list-style-type: none"> <li>for proof test interval or service life according to IEC 61508</li> </ul>	10 a

Electrical Safety

protection class IP on the front according to IEC 60529	IP20
touch protection on the front according to IEC 60529	finger-safe, for vertical contact from the front

Display

display version for switching status	Handle
--------------------------------------	--------

Approvals Certificates

General Product Approval



[Confirmation](#)



[KC](#)

General Product Approval	For use in hazardous locations	Test Certificates	Marine / Shipping
--------------------------	--------------------------------	-------------------	-------------------



[Type Test Certificates/Test Report](#)

[Special Test Certificate](#)



Marine / Shipping	other
-------------------	-------



[Miscellaneous](#)

other	Railway	Environment
-------	---------	-------------

[Confirmation](#)



[Special Test Certificate](#)

[Confirmation](#)



Siemens EcoTech



Environment

**Further information**

**Information on the packaging**

<https://support.industry.siemens.com/cs/ww/en/view/109813875>

**Information- and Downloadcenter (Catalogs, Brochures,...)**

<https://www.siemens.com/ic10>

**Industry Mall (Online ordering system)**

<https://mall.industry.siemens.com/mall/en/en/Catalog/product?mlfb=3RV2032-4KA15>

**Cax online generator**

<http://support.automation.siemens.com/WW/CAXorder/default.aspx?lang=en&mlfb=3RV2032-4KA15>

**Service&Support (Manuals, Certificates, Characteristics, FAQs,...)**

<https://support.industry.siemens.com/cs/ww/en/ps/3RV2032-4KA15>

**Image database (product images, 2D dimension drawings, 3D models, device circuit diagrams, EPLAN macros, ...)**

[http://www.automation.siemens.com/bilddb/cax\\_de.aspx?mlfb=3RV2032-4KA15&lang=en](http://www.automation.siemens.com/bilddb/cax_de.aspx?mlfb=3RV2032-4KA15&lang=en)

**Characteristic: Tripping characteristics, I<sup>2</sup>t, Let-through current**

<https://support.industry.siemens.com/cs/ww/en/ps/3RV2032-4KA15/char>

**Further characteristics (e.g. electrical endurance, switching frequency)**

<http://www.automation.siemens.com/bilddb/index.aspx?view=Search&mlfb=3RV2032-4KA15&objecttype=14&gridview=view1>

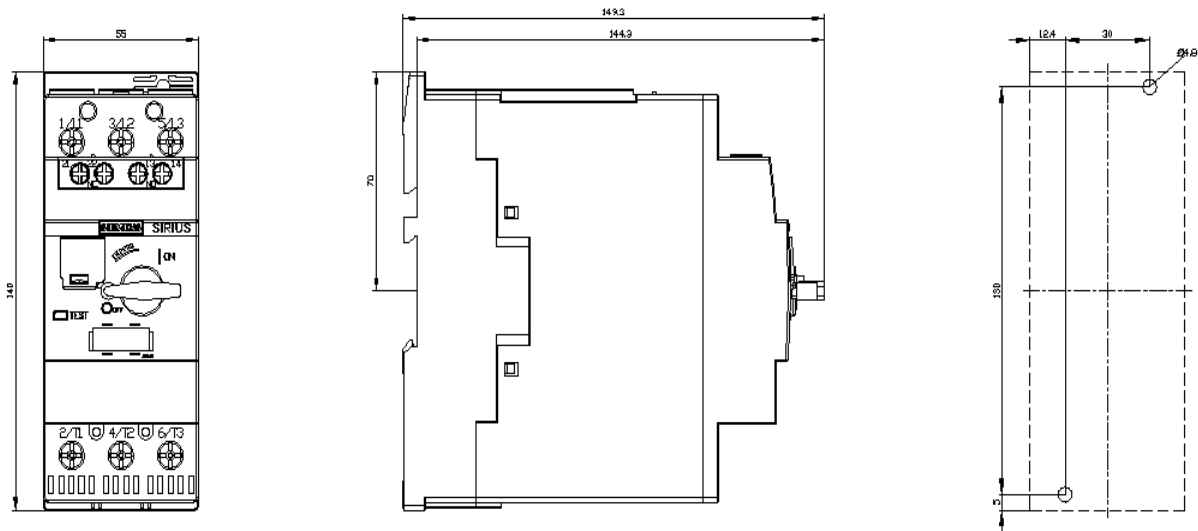

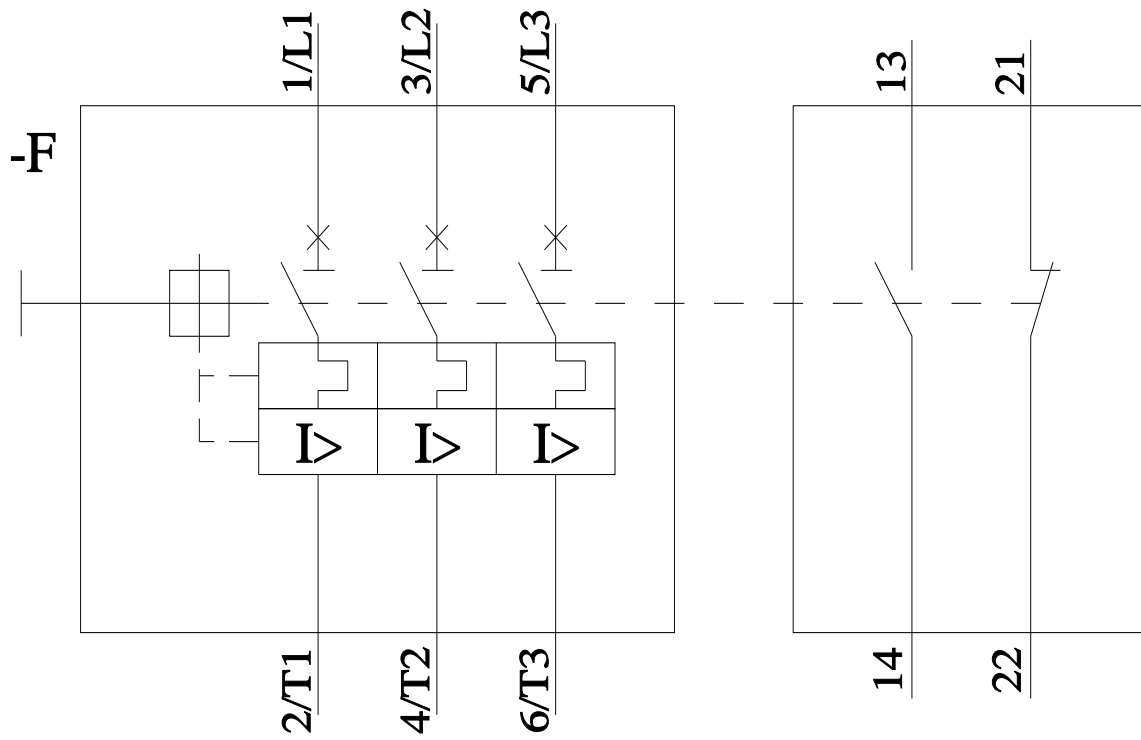

last modified:

11/6/2024 