



<b>6/2</b>	<b>Product overview</b>
<b>6/3</b>	<b>Acoustic and Motion sensing</b>
6/3	Introduction
<b>6/5</b>	<b>Acoustic sensors</b>
6/5	SITRANS DA400 Acoustic diagnostic unit
6/11	SITRANS AS100 Acoustic sensor
6/15	SITRANS CU02 Control Unit
<b>6/18</b>	<b>Motion sensors</b>
6/18	Milltronics MFA 4p Motion failure alarm controller
6/25	Milltronics MSP-7 Motion sensor
6/27	SITRANS WM300 Motion failure alarm controller
6/31	SITRANS WM100 Motion sensor

You can download all instructions, catalogs and certificates for Process Protection free of charge at:  
[www.siemens.com/processprotection](http://www.siemens.com/processprotection)

## Process Protection

### Product overview

#### Overview

	Application	Device description	Page
<b>Acoustic sensor for pump monitoring</b>			
	Acoustic diagnostics unit for flow valve leakage monitoring in oscillating displacement pumps or for material flow monitoring of bulk solids in pipes, conveyors or raceways.	<b>SITRANS DA400</b> <ul style="list-style-type: none"> <li>• 4 inputs for structure-borne noise sensors</li> <li>• 4 universal inputs</li> <li>• 6 digital outputs</li> <li>• With PROFIBUS DP or PROFIBUS PA</li> <li>• Sensor degree of protection IP66/IP68</li> </ul>	6/5
<b>Acoustic sensors for material flow monitoring</b>			
	Acoustic sensor for solids flow detection.	<b>SITRANS AS100</b> <ul style="list-style-type: none"> <li>• Non-invasive</li> <li>• Screw in, bolt on, weld, or bond in place</li> <li>• Analog output</li> <li>• High and low sensitivity range of operation</li> </ul>	6/11
	Alarm control unit for use with SITRANS AS100 acoustic sensor to provide reliable continuous protection for bulk solid flow. It processes signals from the sensor, providing relay and analog outputs for interface into a process.	<b>SITRANS CU02</b> <ul style="list-style-type: none"> <li>• 3 digit LCD display</li> <li>• 4 ... 20 mA output</li> <li>• Two programmable relays</li> <li>• Adjustable independent time delay for each relay</li> <li>• DIN rail mounting provides easy installation</li> </ul>	6/15
<b>Motions sensors</b>			
	Highly sensitive single set point motion sensor alarm unit, used with MSP probes.	<b>Milltronics MFA 4p</b> <ul style="list-style-type: none"> <li>• Probe/target separation up to 100 mm (4 inch)</li> <li>• Minimum velocity of moving ferrous target: 1 cm/sec. (2 fpm)</li> </ul>	6/18
	Heavy duty 3-wire motion sensor that provides an NPN open collector output to PLCs.	<b>Milltronics MSP-7</b> <ul style="list-style-type: none"> <li>• Up to 100 mm (4 inch) gap between target and probe</li> <li>• Corrosion resistant construction</li> </ul>	6/25
	Highly sensitive dual setpoint motion sensor system, used with Milltronics MSP probes.	<b>SITRANS WM300 MFA</b> <ul style="list-style-type: none"> <li>• Up to 100 mm (4 inch) gap between target and probe.</li> <li>• Setpoint adjustment range 2 to 5 000 Hz (120 to 300 000 ppm)</li> </ul>	6/27
	Heavy-duty zero speed alarm switch.	<b>SITRANS WM100</b> <ul style="list-style-type: none"> <li>• Detects the absence or presence of motion of rotating or reciprocating or conveying equipment</li> </ul>	6/31

### Overview

Process protection devices act as early warning systems to avoid costly process interruptions and breakdowns of equipment. Non-contacting motion sensors detect changes in motion and speed of conveying, reciprocating and rotating machinery.

Non-invasive acoustic sensors detect inaudible, high frequency acoustic emissions generated by friction and impact, caused by materials in motion. They can detect conditions of flow/no flow or high/low flow, to warn of blockages, product absence or equipment failure. They are located outside of the process, accurately detecting conditions without wear on the sensor.

Motion sensors can warn in case of equipment malfunction and shut down machinery in case of a slowdown or failure. They are rugged and perform even in harsh industrial conditions. Most of the MFA 4p motion sensing probes, as well as the SITRANS WM100, can be mounted up to 100 mm (4 inch) from the ferrous target, reducing the chance of damage to the probe and the equipment. The probes are not affected by moisture or dust build-up.

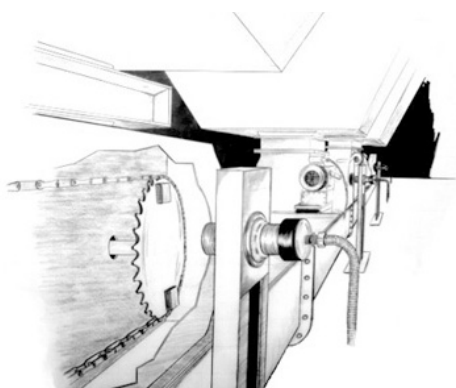

Motion sensing on drive shaft of rotary feeder

### Mode of operation

#### Acoustic Sensing

Acoustic sensors monitor high frequency emissions generated by friction and the impact of flowing material or mechanical parts. The sensors can also sense the turbulence of gases or liquids leaking through valves and flanges. When matter vibrates between 0 Hz and 200 kHz, it creates acoustic energy. Sound energy between 20 Hz and 20 kHz can be detected by humans. Acoustic sensors detect high-frequency acoustic energy between 75 kHz and 175 kHz. Acoustic energy travels quickly through dense materials (metal) and poorly through less dense materials (air). Because the acoustic sensors are mounted directly to the external wall of the chute work, other plant noises are well below 75 kHz and effectively ignored by the sensors.

The acoustic sensors contain a specialized piezocrystal and filter circuit that responds effectively to the high-frequency band between 75 kHz and 175 kHz. As the crystal is excited by the acoustic energy, it produces a continuous electrical signal in direct proportion to the level of acoustic energy received. The SITRANS AS100 sensor output of 0 to 10 V DC can be applied to a PLC or to an optional control unit for a programmable alarm relay or 4 to 20 mA signal output.

#### Motion sensing

Siemens Milltronics probes work on the principle of Faraday's Laws of Electromagnetic Induction. When a ferromagnetic object enters the probe's permanent magnetic field, it distorts the flux, causing its coil windings to generate a voltage. This voltage is proportional to the strength of the magnet and the number of wire turns in the coil (constant in the probes) and the speed at which the ferrous target passes through the flux. The generated voltage is also inversely proportional to the square of the distance between the target and the probe.

The robust motion sensors provide the contacts to shut down machinery whenever under-speed, over-speed or plant equipment failure occurs. On belt, drag and screw conveyors, or on bucket elevators, fans and pumps, the speed alarm option can warn instantly of equipment malfunction. Some probes may be linked to a programmable logic controller to monitor equipment.

## Process Protection

### Acoustic and Motion sensing

#### Introduction

#### Technical specifications

##### Process Protection Selection Guide

Criteria	SITRANS DA400	SITRANS AS100	Milltronics MFA 4p	SITRANS WM300 MFA	Milltronics MSP-7	SITRANS WM100
Typical industries	Mining, water/waste-water, chemicals/petrochemicals and oil & gas industry	Aggregates, grain, cement, food processing, power generation, steel processing	Aggregates, cement, mining, wastewater, grain	Mining aggregate, cement, and other primary and secondary industries.	General industrial applications	Aggregates, cement, mining
Typical Applications	Oscillating displacement pumps such as diaphragm piston pumps, piston pumps and hose-type diaphragm piston pumps. Monitoring of flowing materials in pipes, conveyors or channels.	Pipes, pneumatic conveyors, aerated gravity flow systems, burst filter bag detection	Tail pulleys, driven pulleys, motor shaft sensing, screw conveyor flights, bucket elevators	Tail pulleys, motor shaft sensing, screw conveyor flights, bucket elevators	Tail pulley shafts, driven pulleys, motor shaft sensing, belt or drag conveyors, screw conveyor flights, bucket elevators, fans and pumps	Tail pulleys, driven pulleys, motor shaft sensing, screw conveyor flights, bucket elevators
Operation	Acoustic detection of cavitation, optionally acoustic detection of impact noises of high frequency	Acoustic sensing	Motion sensing	Motion sensing	Motion sensing	Motion sensing
Enclosure	Electronics housing, Makrolon IP65, sensor, stainless steel material number W.-Nr. 1.4571 (316Ti SST)	Compact 304 or 303 stainless steel, IP68	Type 4X/NEMA 4X/IP65 polycarbonate	Polycarbonate	Type 4X/NEMA 4X/IP67 aluminum	Type 4X/NEMA 4X/IP67 aluminum
Sensor mounting	Screw to outside of pump housing. For material flow monitoring on the outside of pipes, channels, chutes or raceways	Sensor non-invasive: glue or weld-on disc, bolt or weld-on tab, drill and tap	Non-contacting probes secured with supplied flange	Non-contacting probes secured with supplied flange	Non-contacting probe secured with supplied flange	Non-contacting, secured with supplied flange
Operating temperature	Electronics: -20 ... +60 °C (-4 ... +140 °F) Sensor: -20 ... +110 °C (-4 ... +230 °F)	-20 ... +80 °C (-4 ... +176 °F) <sup>1)</sup>	-20 ... +50 °C (-4 ... +122 °F) <sup>2)</sup>	-20 ... +50 °C (-4 ... +122 °F)	-40 ... +60 °C (-40 ... +140 °F)	-40 ... +60 °C (-40 ... +140 °F)
Power requirements	19 V ... 36 V DC, < 100 mA	20 ... 30 V DC, 18 mA	100/115/200/230 V AC ± 10 % 50/60 Hz, 15 VA	100 ... 240 V AC, 50/60 Hz, 0.7 ... 0.35 A per LOGO! power module	21 ... 28 V DC, 40 mA max.	115 or 230 V AC ± 10 % 50/60 Hz, 7 VA
Approvals	CE, PROFIBUS DP, and PROFIBUS PA conform, Ex protection to ATEX 1G or 1D	CE, RCM, CSA/FM Class II, Div. 1, Groups E, F, G optional, ATEX II, 2GD, 3D optional, EAC	CSA <sub>US/C</sub> , CE, RCM	CE, CSA/UL <sub>C/US</sub> , FM, EAC, RCM, KCC	CE, RCM	CSA <sub>US/C</sub> , CE, RCM

<sup>1)</sup> Extended temperature model -40 ... +125 °C (-40 ... +257 °F) available (CE version)

<sup>2)</sup> Probes available for -40 ... +260 °C (-40 ... +500 °F)

### Overview



The SITRANS DA400 acoustic diagnostic unit acoustically measures the structure-borne noise

- In the version for pump monitoring; on oscillating displacement pumps
- In the version for material flow monitoring; on pipes, conveying equipment or channels.

It comprises an electric diagnostic unit and up to four acoustic sensors.

### Benefits

#### Benefits when pump monitoring

- Increased availability of the system through:
  - Advanced maintenance planning thanks to early recognition of defective components
  - Reduced downtimes (no fault locating necessary)
  - Increased maintenance intervals
  - Greater pump reliability
- Prevention of expensive consequential damage
- Increased safety of critical applications
- Early recognition of a reduction in power
- Increased productivity

#### Benefits when material flow monitoring

- Detection of insufficient or excessive inflow of material in a liquid or gas flow
- Detection of blockages or clogging
- Reduction of down times
- Increased product quality
- Increased availability
- Guaranteed operational safety
- Increased productivity

### Application

In the version for pump monitoring, the SITRANS DA400 allows continuous, simultaneous and independent monitoring of up to four flow control valves in a pump for leaks. In addition, another four inputs are available for monitoring standard signals (e.g. diaphragm and temperature monitoring). This means that the condition of an oscillating displacement pump is monitored in every phase of its operation.

The SITRANS DA400 is used in all industries where an oscillating displacement pump is used.

The version for material flow monitoring monitors the material flow in liquids or gases that is usually as a result of impact or friction, e.g. against the pipe or channel wall.

If the acoustic diagnostic unit is used in potentially explosive areas, the sensors as well as the acoustic diagnostic unit can be installed in the Ex-zone.

If using the unit in potentially explosive areas, you have two options:

- Operation of the sensors over the safety barriers or
- Operation of the sensors over the SITRANS DA400 with explosion protection

### Function

#### Product features

Continuous and independent status monitoring:

- Of the flow control valves, for leaks
- Of the membranes, for material fatigue
- Of the temperature loading of the hydraulic oil
- Of flowing bulk solids in pipes, conveying equipment or channels

Communication of the status to superordinate control systems:

- Via digital outputs
- Digitally, via PROFIBUS DP or PROFIBUS PA

Simple to operate and parameterize:

- Locally, via digital display and keys
- PROFIBUS DP and PROFIBUS PA

#### Mode of operation

##### Principle of measurement

Leaks in the flow control valves of oscillating displacement pumps are flows in which cavitation occurs. This results in sound waves that are transmitted to the valve housing, where they are recorded by the structure-borne sound sensor in the SITRANS DA400 on the outside.

The SITRANS DA400 utilizes the fact that with both an open valve and a closed intact valve, no cavitation occurs and the measured sound level thus corresponds to the operating noise of the pump. By contrast, with a closed defective valve cavitation does occur, which can be identified by a period increase in the sound level (see figures). The measured value from the SITRANS DA400 corresponds exactly to this increase in the sound level.

In the version for material flow monitoring, SITRANS DA400 continuously detects high-frequency acoustic oscillations by means of structure-born noise sensors.

## Process Protection

### Acoustic sensors

#### SITRANS DA400 Acoustic diagnostic unit

##### Function (continued)

These oscillations are created by:

- Friction and impact of bulk solids in:
  - pipes, raceways or channels
  - chutes
  - conveyors
- Friction and impact of mechanical parts
- Bursting of bubbles
- Cavitation
- Turbulence in gas and liquid flows

The following shows an example of signal levels at an oscillating displacement pump

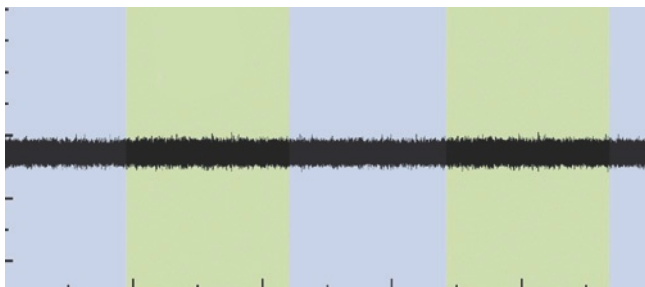

Signal from structure-borne sound sensor with intact valve

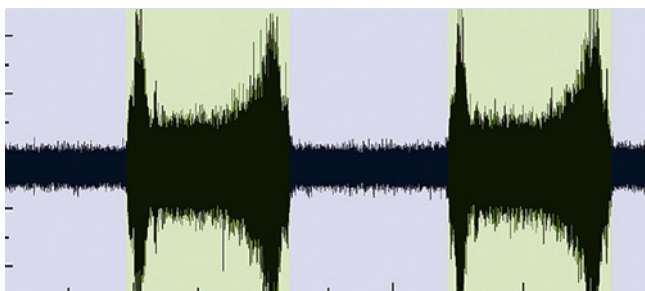

Signal from structure-borne sound sensor with defective valve

##### Sensor operation

The structure-borne sound sensor works on the piezoelectric principle. The structure-borne sound is injected into the sensor via the sensor base (mounting surface) and inside it is converted into an electrical voltage by a piezo-ceramic element. This is amplified in the sensor and transmitted via the cable.

The sensor frequency range lies in the ultrasonic range (> 20 kHz). The sensor is non-directional, i.e. the angle at which the sound wave impacts on the sensor base is not important.

##### Mode of operation of the safety barrier

The safety barrier comprises intrinsically-safe circuits. These circuits serve to operate intrinsically-safe components such as sensors and to isolate safety from the non-hazardous area with the SITRANS DA400 diagnostic unit.

##### Technical specifications

SITRANS DA400	Without Ex protection	With Ex protection
<b>Input</b>		
Acoustic channels	4	
• Cycle time	10 ms	
Only for connection to intrinsically safe sensors with:		
• Max. voltage $U_o$	-	$\leq 5.5$ V
• Max. current $I_o$	-	$\leq 70$ mA
• Max. power $P_o$	-	$\leq 100$ mW
• Internal capacitance $C_i$	-	$\leq 1.2$ $\mu$ F
• Internal inductance $L_i$	-	Negligible
Universal inputs	4	
• Cycle time	80 ms	
• Low pass filter time	1 s	
Universal analog current input		
• Load	< 105 $\Omega$	< 12 $\Omega$
• Resolution	0.1 %	
• Accuracy	0.5 %	
• Fault signal	> 21 mA or < 3.6 mA (at 4 ... 20 mA)	
• Alarm monitoring hysteresis	0.5 %	
• Static destruction limit	40 mA, 4 V	-
For connection with approved intrinsically safe circuits with:		
• Max. supply voltage $U_i$	-	$\leq 30$ V
• Max. short-circuit current $I_i$	-	$\leq 100$ mA
• Max. power $P_{oi}$	-	$\leq 1$ W
• Internal capacitance $C_i$	-	$\leq 11$ nF
• Internal inductance $L_i$	-	$\leq 70$ $\mu$ H
Universal input 24 V digital signal		
• Input resistance	> 19 k $\Omega$	
• Signal level Low	< 4.5 V or open	
• Signal level High	> 7 V	
• Hysteresis	> 1 V	
• Static destruction limit	$\pm 40$ V	-
For connection with approved intrinsically safe circuits with:		
• Max. supply voltage $U_i$	-	$\leq 30$ V
• Max. short-circuit current $I_i$	-	$\leq 100$ mA
• Max. power $P_{oi}$	-	$\leq 1$ W
• Internal capacitance $C_i$	-	$\leq 11$ nF
• Internal inductance $L_i$	-	$\leq 70$ $\mu$ H
Universal input closing contact		
• For connection to closing contact with the maximum values:		
- Max. voltage $U_o$	-	$\leq 10$ V
- Max. current $I_o$	-	$\leq 1$ mA
- Max. power $P_o$	-	$\leq 5$ mW
- Internal capacitance $C_i$	-	$\leq 11$ nF
- Internal inductance $L_i$	-	$\leq 70$ $\mu$ H
8.2 V source for NAMUR signal (DIN EN 60947-5-6)		
• Open circuit voltage	8.2 V $\pm$ 0.3 V, short-circuit proof	-
• Input resistance	< 950 $\Omega$	-
• Static destruction limit for incorrect wiring	+20 V/-10 V	-

### Technical specifications (continued)

SITRANS DA400	Without Ex protection	With Ex protection
<b>Output</b>		
Digital outputs	6	6 (applicable for NAMUR switch hardener)
<ul style="list-style-type: none"> <li>Semiconductor relay</li> <li>Switching voltage</li> <li>Destruction limit</li> <li>Max. switching current</li> <li>Signal status Low (no response)</li> <li>Signal status High (response)</li> </ul>	Individually isolated, short circuit-proof 24 V AC/36 V DC, any polarity 35 V AC, 50 V DC 100 mA - -	- - - - ≤ 1.2 mA (source to DIN 19234) ≥ 2.1 mA (source to DIN 19234)
For connection with an intrinsically safe switching amplifier to DIN 19234 with:		
<ul style="list-style-type: none"> <li>Max. supply voltage <math>U_i</math></li> <li>Max. short-circuit current <math>I_i</math></li> <li>Max. power <math>P_{oi}</math></li> <li>Internal capacitance <math>C_i</math></li> <li>Internal inductance <math>L_i</math></li> </ul>	-	≤ 15.5 V ≤ 25 mA ≤ 64 mW ≤ 5.2 nF Negligible
<b>Conditions of use</b>		
Installation conditions	Vertical wall mounting, cables fed in from below	
Climatic class	Class 4K4 according to EN 60721-3-4	
Mounting location	-	Zone 1 or zone 2
Permissible ambient temperature	-20 ... +60 °C (-4 ... +140 °F)	-
<ul style="list-style-type: none"> <li>Temperature class T5 ... T1</li> <li>Temperature class T6</li> </ul>		-20 ... +60 °C (-4 ... +140 °F) -20 ... +50 °C (-4 ... +122 °F)
Storage temperature	-20 ... +60 °C (-4 ... 140 °F)	
Mechanical load	Class 4M3 according to EN 60721-3-4	
Degree of protection to EN 60529	IP65	
Electromagnetic Compatibility	To EN 61326 and NAMUR NE 21	
<ul style="list-style-type: none"> <li>Emitted interference and interference immunity</li> </ul>		
Usage limits for water		
<ul style="list-style-type: none"> <li>Delivery side</li> <li>Number of strokes</li> </ul>	≥ 10 bar a Min. 4 min <sup>-1</sup> , max. 10 ... 500 min <sup>-1</sup>	
<b>Design</b>		
Weight (without options)	Approx. 2.5 kg	
Dimensions (W x H x D) in mm (inch)	172 x 320 x 80 (6.8 x 12.6 x 3.2)	
Enclosure material	Macrolon (polycarbonate + 20 % glass fiber)	Makrolon (Polycarbonate + 20 % glass fibers), surface attenuated with CrNi layer and painted
Electrical connection via screw terminals	<ul style="list-style-type: none"> <li>Rigid 2.5 mm (0.984 inch)</li> <li>Flexible 1.5 mm (0.59 inch)</li> <li>Flexible with connector sleeves 1.5 mm (0.59 inch)</li> </ul>	
Cable inlet via plastic cable joints	<ul style="list-style-type: none"> <li>2 x Pg 13.5</li> <li>5 x Pg 11</li> </ul>	

SITRANS DA400	Without Ex protection	With Ex protection
<b>Power supply</b>		
Rated voltage	24 V DC	16 V DC
Operating range	19 ... 36 V DC	15 ... 17 V DC
Current consumption	< 100 mA	< 40 mA
For connection with approved intrinsically safe circuits with:		
<ul style="list-style-type: none"> <li>Max. supply voltage <math>U_i</math></li> <li>Max. short-circuit current <math>I_i</math></li> <li>Max. power <math>P_{oi}</math></li> <li>Internal capacitance <math>C_i</math></li> <li>Internal inductance <math>L_i</math></li> </ul>	-	≤ 17.4 V ≤ 191 mA ≤ 1.35 W ≤ 33 nF ≤ 28 μH
<b>Certificates and approvals</b>		
Explosion protection to EN 50014, EN 50020 and EN 50021		
Intrinsic safety "i"	-	TÜV (German Technical Inspectorate) 06 ATEX 2952
Marking	-	II 2(1) G EEx is [ia] IIC T6
<b>Communication</b>		
PROFIBUS DP	RS 485, switchable terminating resistor	
Protocol	Cyclic with Master C1 and acyclic with Master C2	
Power supply	-	Bus-supplied
Bus voltage	-	9 ... 24 V
Current consumption	-	10.5 mA ± 10 %
Bus connection with FISCO supply unit, ia/ib group IIC or IIB	-	Yes
Layer 1 and 2 from PROFIBUS PA, transfer technology from IEC 1158-2	-	
<ul style="list-style-type: none"> <li>C2 connections</li> <li>Device profile</li> <li>Device address</li> </ul>	-	4 connections are supported in master class 2 PROFIBUS PA Profil V3.0 Rev. 1, Class B 1 ... 126 (126 factory-set)
PC parameterization software	SIMATIC PDM (not included in the scope of delivery)	

## Process Protection

### Acoustic sensors

#### SITRANS DA400 Acoustic diagnostic unit

#### Technical specifications (continued)

Sensor for SITRANS DA400	
<b>Setup</b>	<ul style="list-style-type: none"> <li>• Piezoceramic sensor with pre-amplifier</li> <li>• Encapsulated electronics</li> <li>• 4-wire cable with anti-kink sleeve</li> </ul>
<b>Conditions of use</b>	
Permissible ambient temperature	-40 ... +110 °C (-40 ... +230 °F)
Degree of protection to EN 60529	P66/IP68
Mechanical load	Class 4M7 according to EN 60721-3-4
Climatic class	Class 4K4 according to EN 60721-3-4
<b>Design</b>	
Housing material	Stainless steel 1.4571 (316Ti SST)
Cable	Ends with wire protectors and cable shoe for connection to the SITRANS DA400
Weight	125 g (0.276 lb)
Mounting location	Zone 0/1 or zone 20/21/22
Dimensions (W x H x D) in mm (inch)	26 x 29 x 40 (1.02 x 1.14 x 1.57)
<b>Power Supply</b>	Power fed from device
<b>Certificates and approvals</b>	
Explosion protection	
Intrinsic safety "i"	TÜV 2005 ATEX 2876 X
Marking	II 1 G EEx ia IIC T6/T5/T4 or II 1 D EEx ia D 20/21/22 T160
Permissible ambient temperature	
Category 1G	
- Temperature class T4, T5	-20 ... +60 °C (-4 ... +140 °F)
- Temperature class T6	-20 ... +50 °C (-4 ... +122 °F)
• Category 2G	
- Temperature class T4	-40 ... +110 °C (-40 ... +230 °F)
- Temperature class T5	-40 ... +80 °C (-40 ... +176 °F)
- Temperature class T6	-20 ... +65 °C (-4 ... +149 °F)
• Category 1D or 2D	
- Temperature class T160	-40 ... +110 °C (-40 ... +230 °F)
<b>Ex barriers for sensors</b>	
<b>Application area</b>	For the intrinsically safe supply of the acoustic sensors in zone 1; the safety barriers must be installed between the SITRANS DA400 acoustic diagnostic unit and the sensor if only the sensors are being operated in the Ex zone.
<b>Input</b>	A maximum of two sensors can be connected.
<b>Conditions of use</b>	
Degree of protection to EN 60529	IP20
Permissible Ambient Temperature	-20 ... +60 °C (-4 ... +140 °F)
<b>Design</b>	
Weight	115 g (0.254 lb)
Housing material	Plastic, polyamide
Type of installation	Installation on mounting rail NS 32 or NS 35/7.5.  The acoustic diagnostic unit SITRANS DA400 and the safety barrier must be operated outside the Ex zone.
Dimensions (W x H x D) in mm (inch)	68 x 77 x 42 (2.68 x 3.03 x 1.65)

Ex barriers for sensors	
<b>Certificates and Approvals</b>	
Explosion protection	
Intrinsic safety "i"	TÜV 05 ATEX 2917 X
Marking	II (2) G [EEx ib] IIC

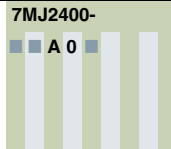
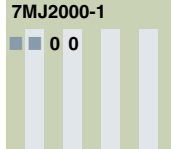
Selection and ordering data	Article No.
<b>SITRANS DA400 Acoustic diagnostic unit</b> Monitors material flow in pipes, leakage in valves or oscillating pumps with up to 4 independent acoustic sensors. <a href="#">Click on the Article No. for the online configuration in the PIA Life Cycle Portal.</a>	<b>7MJ2400-</b> 
<b>Communication</b> <ul style="list-style-type: none"> <li>• PROFIBUS DP</li> <li>• PROFIBUS PA</li> </ul>	<b>1</b> <b>2</b>
<b>Explosion protection</b> <ul style="list-style-type: none"> <li>• Without</li> <li>• With EEx ia/ib to ATEX<sup>1)</sup></li> </ul>	<b>A</b> <b>B</b>
<b>Application software</b> For continuous condition monitoring of positive displacement pumps For material flow monitoring in pipes, raceways and conveyors	<b>1</b> <b>2</b>
<b>SITRANS DA400 Acoustic diagnostic unit</b> Monitors material flow in pipes, leakage in valves or oscillating pumps with up to 4 independent acoustic sensors. <a href="#">Click on the Article No. for the online configuration in the PIA Life Cycle Portal.</a>	<b>7MJ2000-1</b> 
<b>Explosion protection</b> <ul style="list-style-type: none"> <li>• Without</li> <li>• With EEx ia to ATEX</li> </ul>	<b>A</b> <b>B</b>
<b>Cable</b> (incl. pin and allen screw M6) 20 m 40 m 100 m	<b>B</b> <b>C</b> <b>F</b>
<b>Safety barriers for sensors</b> For rail mounting NS 32 and NS35/7.5 in non-hazardous areas Explosion-protected output circuit EEx ib	<b>7MJ2010-1AA</b>

<sup>1)</sup> Not in combination with trigger sensor.

**Dimensional drawings**

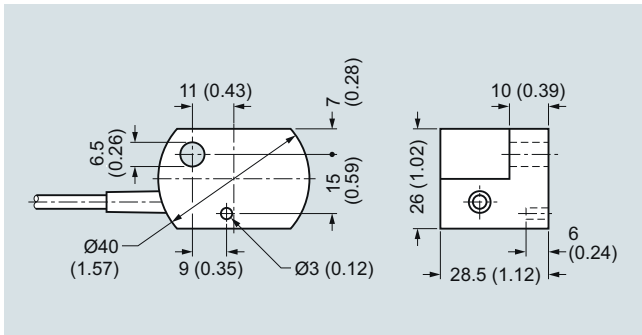

Sensor for SITRANS DA400, dimensions in mm (inch)

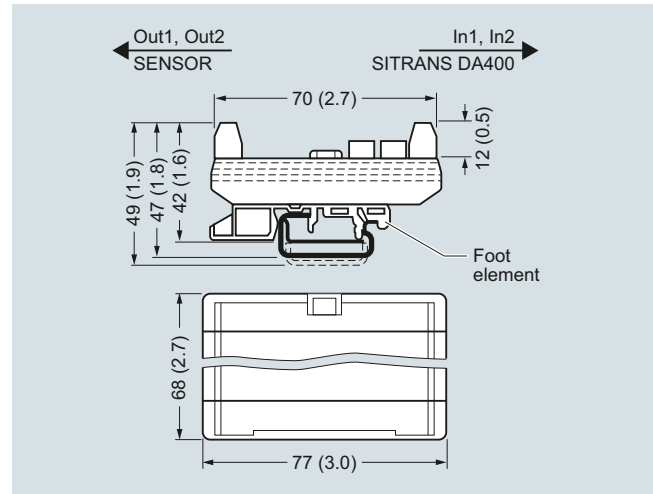

Safety barrier for SITRANS DA400, dimensions in mm (inch)

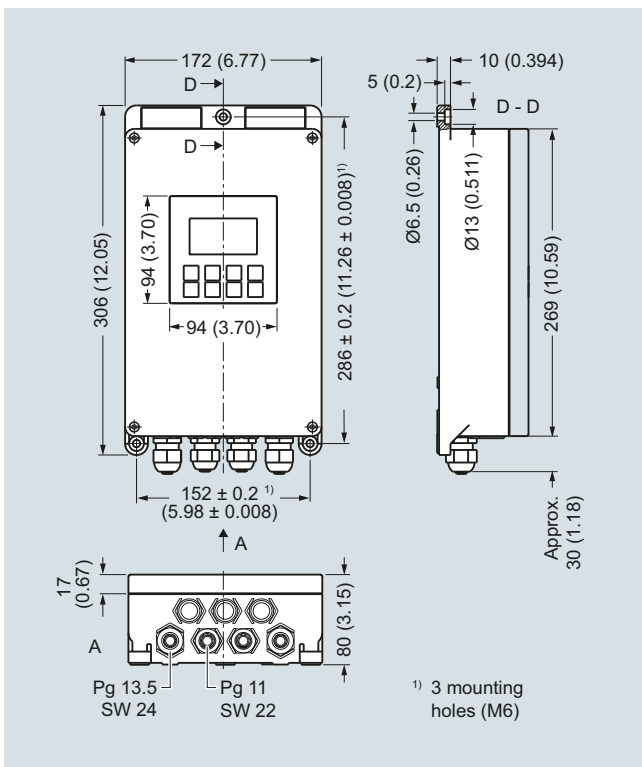

SITRANS DA400, dimensions in mm (inch)

## Process Protection

Acoustic sensors

### SITRANS DA400 Acoustic diagnostic unit

#### Circuit diagrams

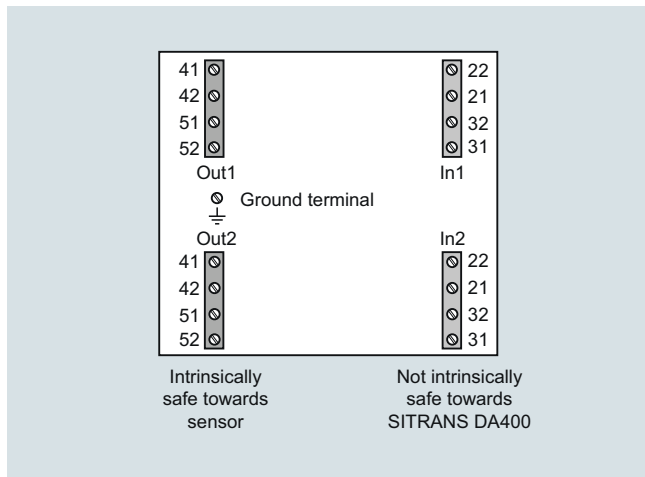

Safety barrier for SITRANS DA400, terminal assignment

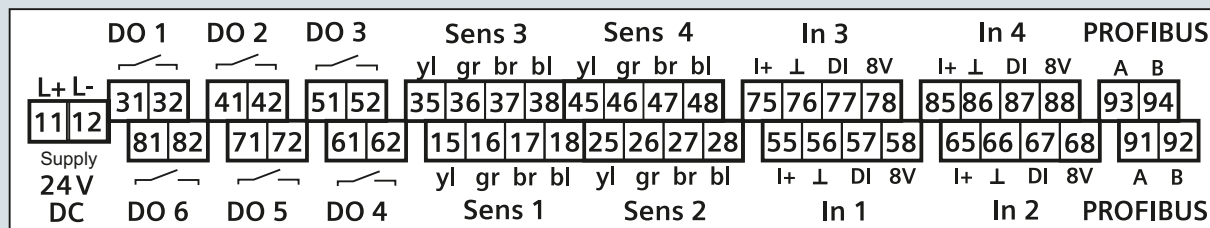

- |       |  |    |                        |    |  |
|-------|--|----|------------------------|----|--|
| L+/L- | Power supply<br>(Any polarity with<br>PROFIBUS PA) | In | Input                  | ⊥  | Ground   |
| DO    | Digital output                                     | yl | Yellow                 | DI | Digital input  |
| Sens  | Sensor   | gr | Green                  | A  | Signal A (green) with PROFIBUS DP,<br>any with PROFIBUS PA |
|       |  | br | Brown                  | B  | Signal B (red) with PROFIBUS DP,<br>any with PROFIBUS PA   |
|       |  | bl | Black                  |    |  |
|       |  | I+ | Analog current input + |    |  |

SITRANS DA400, terminal assignment

### Overview



SITRANS AS100 is an acoustic sensor used for solids flow detection.

### Benefits

- Non-invasive
- Screw in, bolt on, weld, or bond in place
- Analog output
- High and low sensitivity range of operation

### Application

SITRANS AS100 detects changes in high frequency sound waves from equipment and materials in motion. It detects and reacts instantly to changes in solids flow to warn of blockages, product absence, or equipment failure such as burst filter bags. This allows an operator to take early preventative action and avoid costly damage.

Common applications include pellets, powders and most bulk solids in pipes, chutes, vibratory feeders, pneumatic conveyors or aerated gravity flow systems.

Operating with a SITRANS CU02 control unit, the system detects conditions of high flow, low flow or no flow. It can be added to a control loop via a 4 to 20 mA output.

Two relays are fully programmable and independent of each other and can be used to operate an alarm or control device.

With no moving parts and a type 304 or 303 stainless steel enclosure sealed against dust and moisture, this non-invasive unit requires little or no maintenance. With a dual operating range, the sensor offers an exceptionally wide range of application capabilities.

- Key applications: pipes, chutes, vibratory feeders, aerated gravity flow systems, burst filter bag detection

### Design

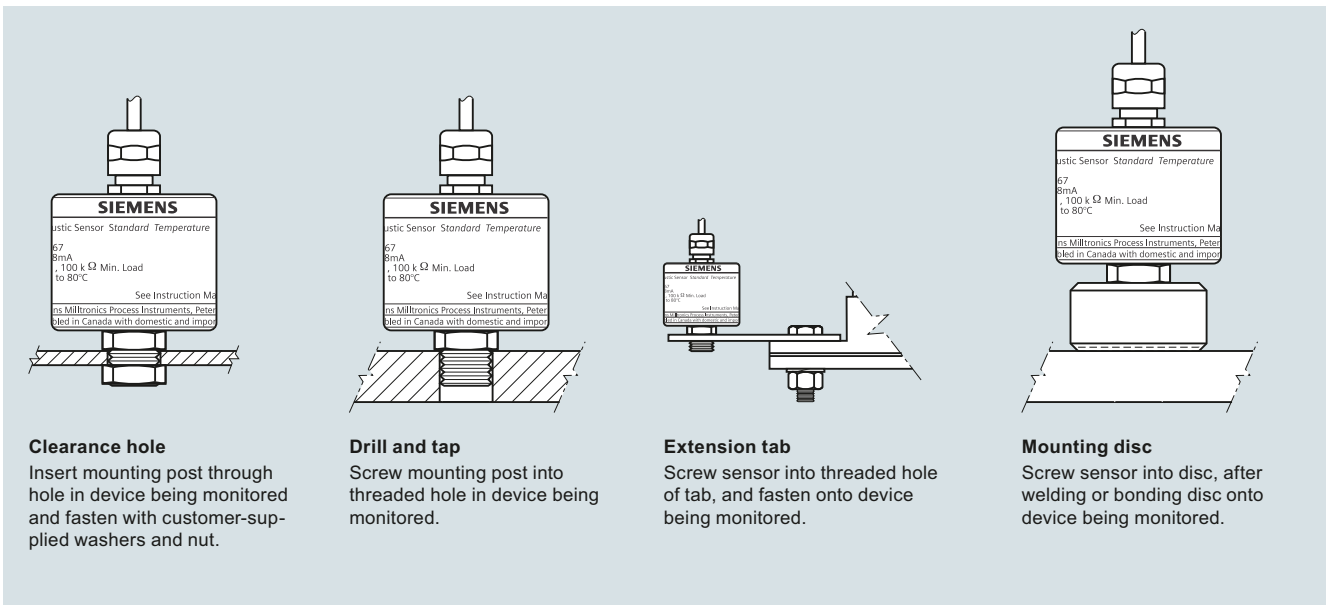

SITRANS AS100 mounting

## Process Protection

### Acoustic sensors

#### SITRANS AS100 Acoustic sensor

##### Technical specifications

Mode of Operation	
Operating principle	Acoustic sensing of high frequency emissions caused by impact or friction
Typical application	<ul style="list-style-type: none"> <li>• Detects burst filter bags in dust collection systems</li> <li>• Detects material being conveyed in pneumatic conveyor lines</li> <li>• Route confirmation in chute work</li> </ul>
Model	
Standard	Standard operating temperature range
Extended	Extended operating temperature range
Operation	
Relative sensitivity	0.5 %/°C of reading, average over the operating range
Outputs	Analog, 0.08 ... 10 V DC nominal, 100 kΩ minimum load impedance
Rated operating conditions	
Amb. temperature for enclosure	<ul style="list-style-type: none"> <li>• Standard</li> <li>• Extended</li> </ul>
	-20 ... +80 °C (-4 ... +176 °F) <ul style="list-style-type: none"> <li>• -40 ... +125 °C (-40 ... +257 °F) (CE only)</li> <li>• -30 ... +120 °C (-22 ... +248 °F) option</li> </ul>
Storage temperature	<ul style="list-style-type: none"> <li>• Standard</li> <li>• Extended</li> </ul>
	-20 ... +80 °C (-4 ... +176 °F) <ul style="list-style-type: none"> <li>• -40 ... +125 °C (-40 ... +257 °F) (CE only)</li> <li>• -30 ... +120 °C (-22 ... +248 °F) option</li> </ul>
Design	
Weight	0.4 kg (1 lb)
Enclosure	Enclosure: 304 (1.4301) stainless steel [303 stainless steel (1.4305) on Class II version, aluminum 231 on 2GD version]
Degree of protection	IP68 (waterproof)
Cable	
• Standard	4 m (13 ft) cable, PVC jacketed, 3 twisted pairs, 24 AWG (0.25 mm <sup>2</sup> ), shielded
• Extended	4 m (13 ft) cable, thermoplastic elastomer jacketed, 6 conductor, 24 AWG (0.25 mm <sup>2</sup> ) conductor, shielded
Power supply	
	20 ... 30 V DC, 18 mA (typical)
Certificates and approvals	
	CE, RCM, EAC, KCC CSA/FM Class II, Div. 1, Group E, F, and G (optional), ATEX II 2GD (optional), ATEX II 3D (optional), EAC Ex

##### Selection and ordering data

SITRANS AS100 Acoustic sensor		Article No.
Non-invasive, for detection of solids flow.		7MH7560-
↗ Click on the Article No. for the online configuration in the PIA Life Cycle Portal.		0
Sensor		
Standard temperature range [-20 ... +80 °C (-4 ... +176 °F)] <sup>1)</sup>		1
Extended temperature range [-40 ... +125 °C (-40 ... +257 °F)] <sup>2)</sup>		3
Extended temperature range [-30 ... +120 °C (-22 ... +248 °F)] <sup>3)</sup>		4
Cable Length		
4 m (13.12 ft)		A
Sensor Mounting		
None		A
Mounting disk		B
Mounting tab		C
Approvals		
CE, RCM, EAC, KCC		1
CSA/FM Class II, Div. 1, Group E, F, and G (includes ½" NPT female fitting)		3
CSA Class II, Div. 1, Group E, F, and G (includes ½" NPT female fitting)		4
CE, RCM, FM/CSA Class II, Div. 1, Group E, F and G, ATEX II 3D (includes M20 female fitting), EAC Ex		5
ATEX II 2GD, c/w cable gland, EAC Ex <sup>4)</sup>		6

##### Selection and ordering data

Further designs		Order code
Please add "-Z" to Article No. and specify Order code(s).		
Manufacturer's test certificate: According to EN 10204-2.2		C11
Acrylic coated, stainless steel tag [12 x 45 mm (0.5 x 1.75 inch)]: Measuring-point number/identification (max. 16 characters), specify in plain text		Y17
Operating Instructions		
All literature is available to download for free, in a range of languages, at <a href="http://www.siemens.com/processinstrumentation/documentation">http://www.siemens.com/processinstrumentation/documentation</a>		
Spare Parts		Article No.
Mounting tab		7MH7723-1AA
Mounting disk		7MH7723-1AB
½" NPT adapter kit for standard temperature range sensor, not Class II approved		7MH7723-1BW
M20 adapter kit for standard temperature range sensor, not Class II or ATEX approved		7MH7723-1BV
½" NPT adapter kit for extended temperature range sensor, not Class II approved Note: Adapter kits are not CSA Class II approved		7MH7723-1BX



# Process Protection

## Acoustic sensors

### SITRANS AS100 Acoustic sensor

#### Circuit diagrams

##### Standard temperature range

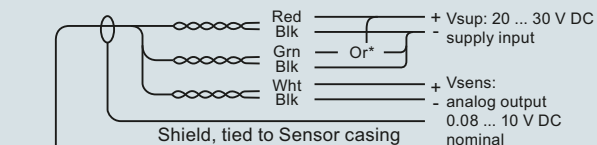

\* Sensor range selection  
 High sensitivity range = red and green to Vsup+  
 Low sensitivity range = red to Vsup+, green to Vsup-

##### Extended temperature range

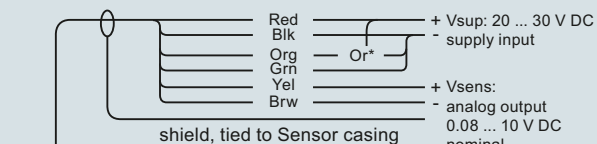

\* Sensor range selection  
 High sensitivity range = red and orange to Vsup+  
 Low sensitivity range = red to Vsup+, orange to Vsup-

#### Interconnection

The longer the cable, the more susceptible it is to noise and earth loops. It is therefore recommended to use cable with heavy gauge conductors and good RF/electrical shielding (copper braid rather than drain and foil). A proper junction box close to the sensor is an ideal location not only to extend the cable but also to configure the wiring for high or low sensitivity range operation.

The following table provides a guideline for suitable wire gauges where distances are considerable.

Max. distance between sensor and supply  
 (24 V or Control Unit).

AWG	Wire size		Distance	
	mm	mm <sup>2</sup>	meters	feet
24	7 x 0.20	0.25	500	1 600
22	7 x 0.25	0.35	800	2 600
20	10 x 0.25	0.5	1 200	3 900

SITRANS AS100 connections

## Overview



SITRANS CU02 is an alarm control unit, for use with SITRANS AS100 acoustic sensor, that provides reliable continuous protection for bulk solids flow.

## Benefits

- 4 to 20 mA output
- Two programmable relays
- Adjustable independent time delay for each relay
- Adjustable start-up time delay
- DIN rail mounting provides easy installation
- Built-in password protection to parameters

## Application

SITRANS CU02 receives a 0 to 10 V DC input signal from the SITRANS AS100 sensor, providing relay and analog outputs for interface into a process.

- Key applications: with SITRANS AS100 for bulk solids flow

## Function

The system can be readily configured for set points indicating such conditions as high flow, low flow or no flow. Alternatively, it can be added to a control loop via a 4 to 20 mA isolated output for trend monitoring proportional to the signal from the sensor.

Two relays are fully programmable and independent of each other and can be used to operate an alarm or control device. Alarming may be provided above or below a setpoint or within a band. Readings are also displayed locally by the SITRANS CU02 on its LCD.

The SITRANS CU02 may be mounted up to 500 m (1 500 ft) from the sensor.

## Technical specifications

<b>Mode of operation</b>	
Measuring principle	Controller for acoustic sensing (SITRANS AS100)
Typical application	Connects to SITRANS AS100 to detect burst filter bag
<b>Input</b>	
	0 ... 10 V DC, from sensor
<b>Output</b>	
Output signal	4 ... 20 mA isolated output, 2 Form C relays - latching or non-latching - 5 amp at 250 V AC non-inductive
Sensor excitation	26 V DC
Max. load	750 Ω
<b>Rated operating conditions</b>	
Installation conditions	Indoor
• Location	
Ambient conditions	
• Ambient temperature for enclosure	-20 ... +50 °C (-4 ... +122 °F)
• Storage temperature	-20 ... +50 °C (-4 ... +122 °F)
• Relative humidity	80 % for temperatures up to 50 °C (122 °F)
• Degree of protection	IP20
• Installation category	II
• Pollution degree	2
<b>Design</b>	
Weight	550 g (18 oz)
Dimensions (W x H x D)	55 x 75 x 110 mm (2.2 x 3 x 4.4 inch)
Material enclosure	Polycarbonate
Mounting	DIN Rail (DIN 46277 or DIN EN 50022), or wall mount, up to 500 m (1 500 ft) from sensor
Cable	2 twisted pair, 24 AWG (22 mm <sup>2</sup> ), shielded. Mount up to 500 m (1 500 ft) from sensor
<b>Display</b>	
	Liquid crystal, three digits, 9 mm (0.35 inch), high and multi-segment graphic symbols for operation status
<b>Power supply</b>	
Supply voltage	100, 115, 200, 230 V AC ± 15 %, 50/60 Hz, factory set
Power consumption	Max. 10 VA
<b>Approvals</b>	
	CSA <sub>US/CA</sub> , CE, RCM, EAC, KCC

## Process Protection

### Acoustic sensors

#### SITRANS CU02 Control Unit

##### Selection and ordering data

###### SITRANS CU02 Control unit

Set-point alarm controller, for use with AS100 acoustic sensor.

➤ Click on the Article No. for the online configuration in the PIA Life Cycle Portal.

###### Power Supply

100 V AC

115 V AC

200 V AC

230 V AC

###### Enclosure

Standard DIN Rail

###### Approvals

CSA<sub>US/C</sub>, CE, RCM, EAC, KCC

##### Article No.

7MH7562-

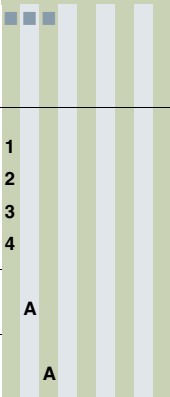

##### Selection and ordering data

###### Further designs

Please add "-Z" to Article No. and specify Order code(s).

Manufacturer's test certificate: According to EN 10204-2.2

Acrylic coated, stainless steel tag [38 x 51 mm (1.5 x 2 inch)]:  
Measuring-point number/identification (max. 16 characters), specify in plain text

###### Operating Instructions

All literature is available to download for free, in a range of languages, at <http://www.siemens.com/processinstrumentation/documentation>

##### Order code

C11

Y18

#### Dimensional drawings

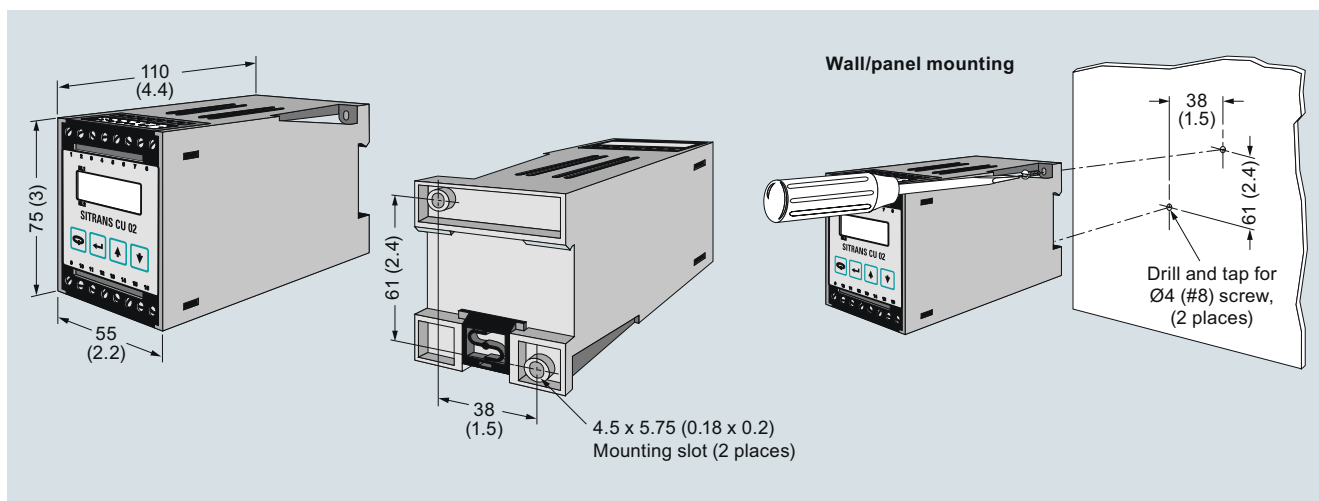

SITRANS CU02, dimensions in mm (inch)

**Circuit diagrams**

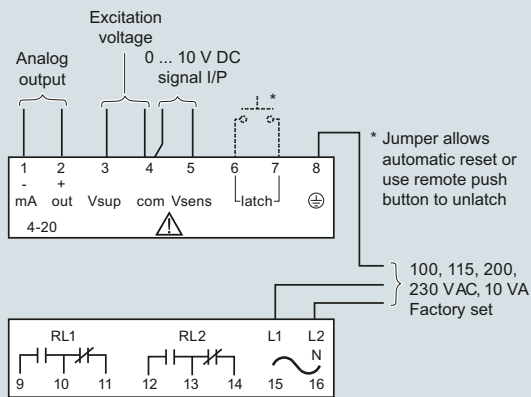

**Standard temperature version**

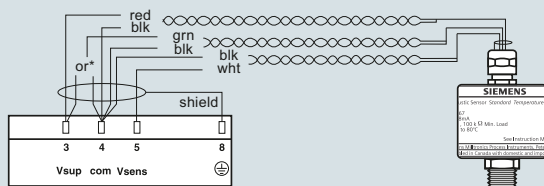

\* Sensor range selection  
High sensitivity range = green to 'Vsups'  
Low sensitivity range = green to 'com'

**Extended temperature version**

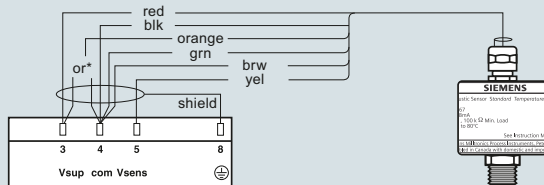

\* Sensor range selection  
High sensitivity range = orange to 'Vsups'  
Low sensitivity range = orange to 'com'

**Mounting**

Installation shall only be performed by qualified personnel and in accordance with local governing regulations. This product is susceptible to electrostatic shock. Follow proper grounding procedures.

**Interconnection**

All field wiring must have insulation suitable for at least 250 V. Relay contact terminals are for use with equipment having no accessible live parts and wiring having insulation suitable for at least 250 V. The maximum allowable working voltage between adjacent relay contacts shall be 250 V. If sensor case is grounded, do not connect shield of cable to SITRANS CU02 ground terminal.

SITRANS CU02 connections

## Process Protection

### Motion sensors

#### Milltronics MFA 4p Motion failure alarm controller

##### Overview



MFA 4p motion failure alarm controller is a highly sensitive single setpoint motion sensor system, used with Milltronics MSP probes.

##### Benefits

- Up to 100 mm (4 inch) gap between target and probe
- Switch selectable overspeed or underspeed detection
- Setpoint adjustment 0.15 to 3 000 PPM (pulses/minute)
- Adjustable start-up time delay
- Visual indication of probe operation and relay status
- General purpose, suitable for majority of industrial applications; rugged probe designs provide unmatched reliability

##### Application

The MFA 4p detects changes in the motion and speed of rotating, reciprocating or conveying equipment. It warns of equipment malfunction and signals through contacts to shut down machinery in case of a slowdown or failure. Its reliability makes it a cost-effective way to protect valuable process equipment.

The single setpoint system suits most industrial applications. This versatile unit can be used on tail pulley shafts, driven pulleys, motor shaft sensing, belt or drag conveyors, screw conveyor flights, bucket elevators, fans and pumps.

A special feature is the adjustable 0 to 60 second time delay, allowing the monitored device to accelerate to normal running speed before monitoring begins. A wide range of probes are available to suit specific needs, including high temperatures and corrosive installations. The CE approval allows the MFA 4p to consistently meet the needs of the mining aggregate, cement and other primary and secondary industries.

- Key Applications: tail pulleys, motor shaft sensing, screw conveyor flights, bucket elevators

## Design

### Mounting for Milltronics MSP-12, MSP-3, XPP-5

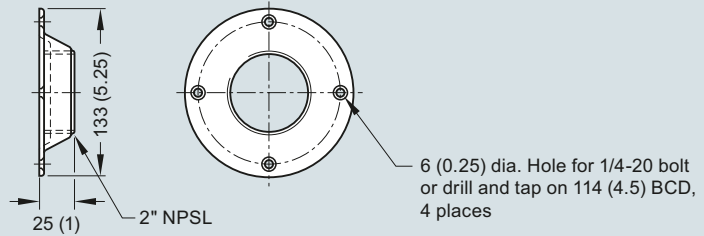
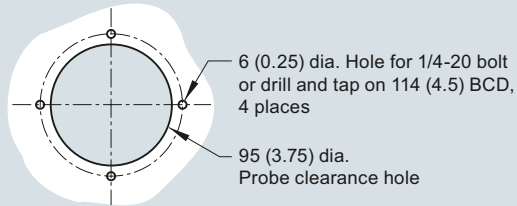

**Note:** Mounting flange supplied with probe.

### Mounting for Milltronics MSP-9

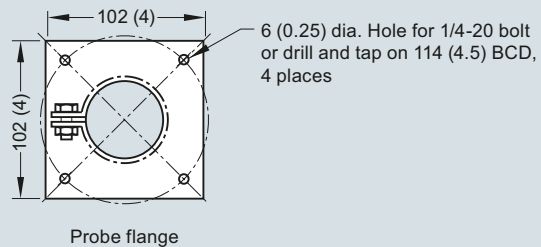
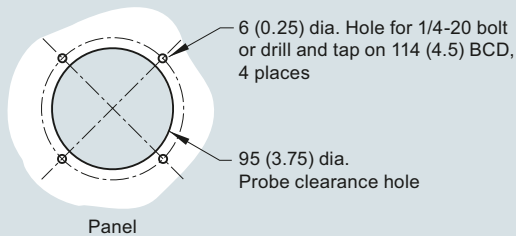

Milltronics MSP-12, MSP-3, MSP-9, XPP-5 mounting, dimensions in mm (inch)

6

#### Standard Milltronics MSP-12



- Heavy-duty general purpose motion probe
- Long lasting aluminum body with internal amplifier
- Convenient mounting flange and locknut for fast installation and setup
- Temperature rating: -40 ... +60 °C (-40 ... +140 °F)
- Enclosure rating: Type/NEMA 4X, 6, IP67



#### High temperature Milltronics MSP-3

- Heavy-duty, high temperature aluminum probe designed to withstand operating temperatures from -50 ... 260 °C (500 °F)
- Cast aluminum probe with convenient mounting flange and locknut
- 1.5 m (5 ft) of high temperature PTFE cable provided. Up to 30 m (100 ft) may be used.
- Amplifier remote mounted in enclosure 140 x 140 x 100 mm (5.5 x 5.5 x 4 inch), available in cast aluminum (½" NPT conduit entry), painted steel (Type/NEMA 4, IP65 rating), or stainless steel (Type/NEMA 4X, IP65 rating)
- Amplifier temperature rating -40 ... +60 °C (-40 ... +140 °F)
- Enclosure rating: Type/NEMA 4X, 6, IP67

#### Milltronics XPP-5



- CSA hazardous approval (Class I, Div. 1, Groups A, B, C, D; Class II Div. 1, Groups E, F, G; Class III)
- Aluminum body that is fully potted
- Convenient mounting flange and locknut
- 3/4" NPT male hub connection
- Operating temperature from -40 ... 60 °C (-40 ... 140 °F)
- Enclosure rating: Type/NEMA 4X, 6, IP67



#### Stainless high temperature Milltronics MSP-9

- Heavy-duty, high temperature 304 stainless steel probe
- Special construction allows operation of probe in environment from -50 ... 260 °C (500 °F)
- 1.5 m (5 ft) special high temperature PTFE cable provided. Up to 30 m (100 ft) may be used.
- Amplifier remote mounted in enclosure 140 x 140 x 100 mm (5.5 x 5.5 x 4 inch), available in cast aluminum (½" NPT conduit entry), painted steel (Type/NEMA 4, IP65 rating), or stainless steel (Type/NEMA 4X, IP65 rating)
- Enclosure rating: Type/NEMA 4X, 6, IP67
- Amplifier temperature rating -40 ... +60 °C (-40 ... +140 °F)

#### Milltronics RMA (Remote Mounted Amplifier)

- Available for internal mounting within Probe, or in enclosure for remote mounting
- Enclosures available in cast aluminum (½" NPT entry), painted steel (Type/NEMA 4 rating) or stainless steel (Type/NEMA 4X, IP65 rating)
- Operating temp. from -40 ... +60 °C (-40 ... +140 °F)
- Enclosure rating: Type/NEMA 4X, 6, IP67



## Process Protection

### Motion sensors

#### Milltronics MFA 4p Motion failure alarm controller

##### Technical specifications

<b>Mode of operation</b>	
Measuring principle	Motion monitor and alarm
Typical application	Monitoring loss of motion in tail pulley, screw flights, bucket elevators
<b>Features</b>	
	<ul style="list-style-type: none"> <li>• Switch selectable overspeed or underspeed detection</li> <li>• Setpoint adjustment: 0.15 ... 3 000 PPM</li> <li>• Adjustable start-up time delay: 0 ... 60 seconds</li> <li>• Visual indication of probe operation and relay status</li> </ul>
<b>Output</b>	
	2 relays working in unison, each providing 1 SPDT Form C relay contact, rated 8 A at 250 V AC resistive
<b>Performance</b>	
Repeatability	± 1 %
Dead band	± 0.25 %
<b>Dynamic Range</b>	
	0 ... 7 200 PPM
<b>Ambient Temperature Range</b>	
	-20 ... +50 °C (-5 ... +122 °F)
<b>Storage temperature</b>	
	-20 ... +50 °C (-5 ... +122 °F)
<b>Design</b>	
Enclosure rating	Type 4X/NEMA 4X/IP65 (standard and optional stainless steel) Type 4/NEMA 4/IP65 (optional mild steel)
Enclosure dimensions	160 x 240 x 82 mm (6.3 x 9.5 x 3.2 inch) Optional: mild steel or 304 (1.4301) stainless steel 203 x 254 x 102 mm (8 x 10 x 4 inch)
Enclosure material	Polycarbonate Optional: mild steel or stainless steel
<b>Power Supply</b>	
	100 ... 240 V AC, 50/60 Hz, 15 VA, ± 10 % of rated voltage
<b>Certificates and approvals</b>	
	CE, RCM, EAC, KCC, CSA <sub>US/C</sub> , FM

Selection and ordering data	Article No.		Article No.	
<b>Milltronics MFA 4p Motion failure alarm controller</b> Set-point alarm controller, for use with MSP motion probes. ↗ Click on the Article No. for the online configuration in the PIA Life Cycle Portal.	<b>7MH7144-</b>		<b>Milltronics RMA Remote mounted amplifier</b> Remote mounted amplifier for Milltronics MSP-3 and MSP-9 motion sensing probes. ↗ Click on the Article No. for the online configuration in the PIA Life Cycle Portal.	<b>7MH7145-</b>
<b>Enclosure</b> NEMA 4X, polycarbonate enclosure NEMA 4, painted mild steel enclosure NEMA 4X, 304 (1.4301) stainless steel enclosure	<b>1</b> <b>2</b> <b>3</b>		<b>Enclosure</b> Aluminum enclosure, IP65, Type/NEMA 4X, ½" NPT entry Painted steel, Type/NEMA 4, IP65 rating 304 (1.4301) stainless steel enclosure, Type/NEMA 4X, IP65 rating	<b>0</b> <b>A</b> <b>C</b> <b>D</b>
<b>Input Voltage</b> 100 ... 240 V AC, ± 10 %, 50/60 Hz, 15 VA	<b>A</b>		<b>Further designs</b> Please add "-Z" to Article No. and specify Order code(s). Manufacturer's test certificate: According to EN 10204-2.20 Acrylic coated, stainless steel tag [38 x 51 mm (1.5 x 2 inch)]: Measuring-point number/identification (max. 16 characters), specify in plain text	Order code <b>C11</b> <b>Y18</b>
<b>Speed detection version</b> Standard, underspeed (U/S) or overspeed (O/S), switch selectable Slow speed (S/S), U/S or O/S detection, switch selectable (limit of 15 ppm)	<b>A</b> <b>B</b>		<b>Operating Instructions</b> All literature is available to download for free, in a range of languages, at <a href="http://www.siemens.com/processinstrumentation/documentation">http://www.siemens.com/processinstrumentation/documentation</a>	
<b>Approvals</b> CE, RCM, EAC, KCC, CSA <sub>US/C</sub> , FM	<b>2</b>		<b>Spare Parts</b> Card, RMA	Article No. <b>7MH723-1DT</b>
<b>Further designs</b> Please add "-Z" to Article No. and specify Order code(s). Manufacturer's test certificate: According to EN 10204-2.2 Acrylic coated, stainless steel tag [69 x 50 mm (2.7 x 1.97 inch)]: Measuring-point number/identification (max. 27 characters), specify in plain text Painted mild steel, heated enclosure with viewing window for use down to -50 °C (-58 °F) (finished unit is mounted inside enclosure) [483 x 584 x 203 mm (19 x 23 x 8 inch)] Stainless steel, sun/weather shield (finished unit is field mounted inside enclosure) [357 x 305 x 203 mm (14 x 12 x 8 inch)]	Order code <b>C11</b> <b>Y15</b> <b>A35</b> <b>S50</b>			
<b>Operating Instructions</b> All literature is available to download for free, in a range of languages, at <a href="http://www.siemens.com/processinstrumentation/documentation">http://www.siemens.com/processinstrumentation/documentation</a>				
<b>Spare Parts</b> Circuit Card, standard Circuit Card, Slow speed Lid with overlay for MFA 4p	Article No. <b>7MH723-1DU</b> <b>7MH723-1DV</b> <b>7MH723-1GY</b>			

## Process Protection

### Motion sensors

#### Milltronics MFA 4p Motion failure alarm controller

Selection and ordering data	Article No.
<p><b>Milltronics Motion sensing probes</b></p> <p>Heavy duty, 100 mm measuring range, for use with RMA, MFA 4p, WM300 MFA, or other control.</p> <p>Note: Milltronics MSP-3 and MSP-9 probes require the use of Milltronics RMA (amplifier)</p> <p>➤ Click on the Article No. for the online configuration in the PIA Life Cycle Portal.</p>	<p><b>7MH7146-</b></p>
<p><b>Cable Length</b></p> <p>Standard length (as described in Model options)<sup>1)</sup></p> <p>Add Order code Y01 and plain text: "Total cable length ... m"</p> <p>Extended cable length 2 ... 30 m (6.6 ... 98.4 ft)<sup>2)</sup></p> <p>Extended cable length 31 ... 50 m (101.7 ... 164 ft)<sup>4)</sup></p> <p>Extended cable length 51 ... 100 m (167.3 ... 328.1 ft)<sup>4)</sup></p>	<p><b>0</b></p> <p><b>1</b></p> <p><b>2</b></p> <p><b>3</b></p>
<p><b>Model [standard cable length/type]</b></p> <p>MSP-3, ½" NPT cable inlet<sup>3)</sup> [1.5 m (5 ft) high temperature cable]</p> <p>MSP-9 [1.5 m (5 ft) high temperature cable]<sup>3)</sup></p> <p>MSP-12, ½" NPT cable inlet, no cable</p> <p>XPP-5 [1.5 m (5 ft) cable, (CSA Class I, Groups A, B, C and D; Class II Groups E, F, and G)]</p> <p>XPP-5 [10 m (32.8 ft) cable, (CSA Class I, Groups A, B, C, and D; Class II Groups E, F, and G)]</p> <p>XPP-5 [15 m (49.2 ft) cable, (CSA Class I, Groups A, B, C, and D; Class II Groups E, F, and G)]</p>	<p><b>B</b></p> <p><b>D</b></p> <p><b>E</b></p> <p><b>G</b></p> <p><b>H</b></p> <p><b>J</b></p>
<p><b>Approvals</b></p> <p>CE, RCM, EAC, KCC</p>	<p><b>A</b></p>
<p><b>Further designs</b></p> <p>Please add <b>"-Z"</b> to Article No. and specify Order code(s).</p> <p>Total cable length: enter the total cable length in plain text description</p> <p>Acrylic coated, stainless steel tag [13 x 45 mm (0.5 x 1.75 inch)]: Measuring-point number/identification (max. 16 characters), specify in plain text</p> <p>Cable gland kit</p> <p>Manufacturer's test certificate: According to EN 10204-2.2</p>	<p>Order code</p> <p><b>Y01</b></p> <p><b>Y17</b></p> <p><b>A57</b></p> <p><b>C11</b></p>
<p><b>Operating Instructions</b></p> <p>All literature is available to download for free, in a range of languages, at <a href="http://www.siemens.com/processinstrumentation/documentation">http://www.siemens.com/processinstrumentation/documentation</a></p>	
<p><b>Spare Parts</b></p> <p>Locknut, for MSP-3, MSP-7, MSP-12, XPP-5</p> <p>Mounting flange, for MSP-3, MSP-7, MSP-12, XPP-5</p> <p>Mounting bracket for MSP-9</p> <p>Lid, 1/2" NPT cable inlet for MSP-3, MSP-7, MSP-12</p> <p>Lid for MSP-9</p> <p>Lid gasket, for MSP-3, MSP-9</p> <p>Lid gasket, for MSP-7, MSP-12</p> <p>Motion cable gland adaptor kit</p>	<p><b>Article No.</b></p> <p><b>7MH7723-1CR</b></p> <p><b>7MH7723-1CS</b></p> <p><b>7MH7723-1CT</b></p> <p><b>7MH7723-1CU</b></p> <p><b>7MH7723-1CV</b></p> <p><b>7MH7723-1CW</b></p> <p><b>7MH7723-1CX</b></p> <p><b>7MH7723-1JU</b></p>

<sup>1)</sup> No Y01 needed in Order code for standard length.

<sup>2)</sup> Only available with model options B, D, G, H, J.

<sup>3)</sup> MSP-3 and MSP-9 probes required the use of RMA (amplifier).

<sup>4)</sup> Available with Model options G, H, and J only.

**Dimensional drawings**

**Type 4X/NEMA 4X/IP65 Polycarbonate Enclosure**

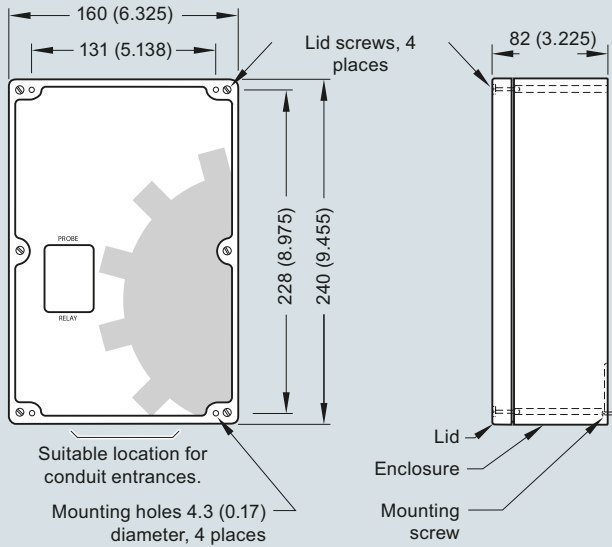

**Type 4/NEMA 4/IP65 Painted Steel Enclosure & Type 4X/NEMA 4X/IP65 Stainless Steel Enclosure**

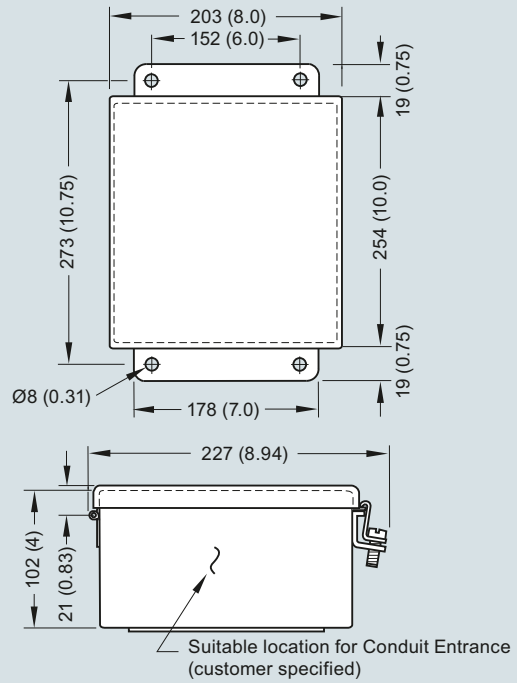

**Standard Probe MSP-12**

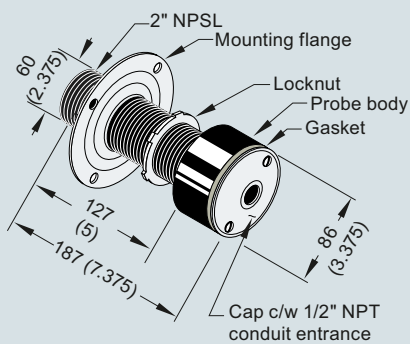

**Hazardous Locations XPP-5**

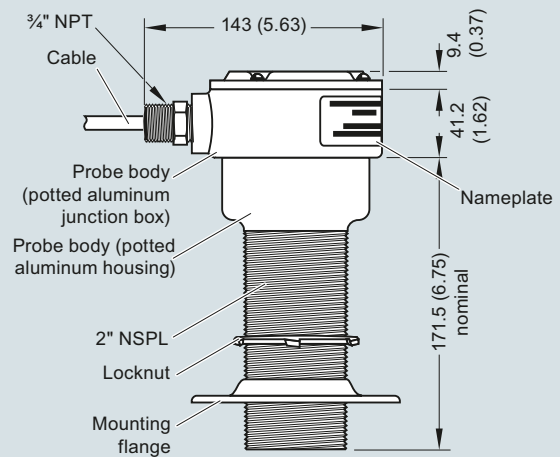

Milltronics MFA 4p and probe, dimensions in mm (inch)

## Process Protection

### Motion sensors

#### Milltronics MFA 4p Motion failure alarm controller

#### Dimensional drawings (continued)

High temperature probe MSP-3

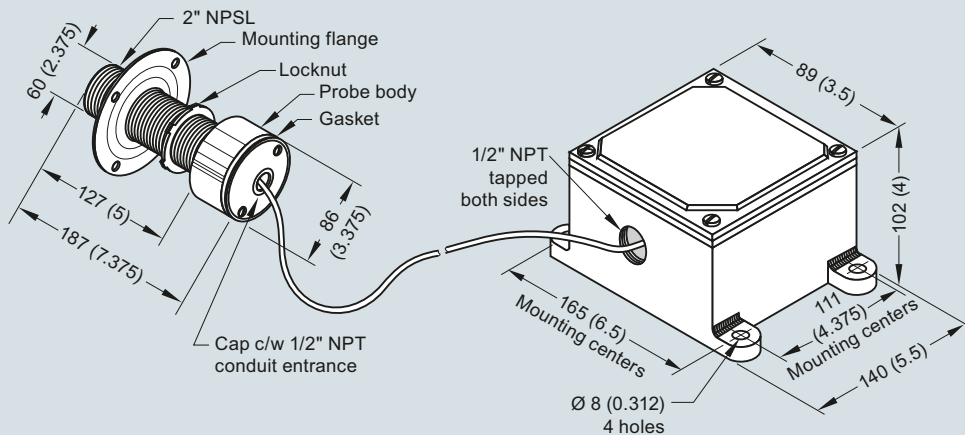

High temperature stainless steel probe MSP-9

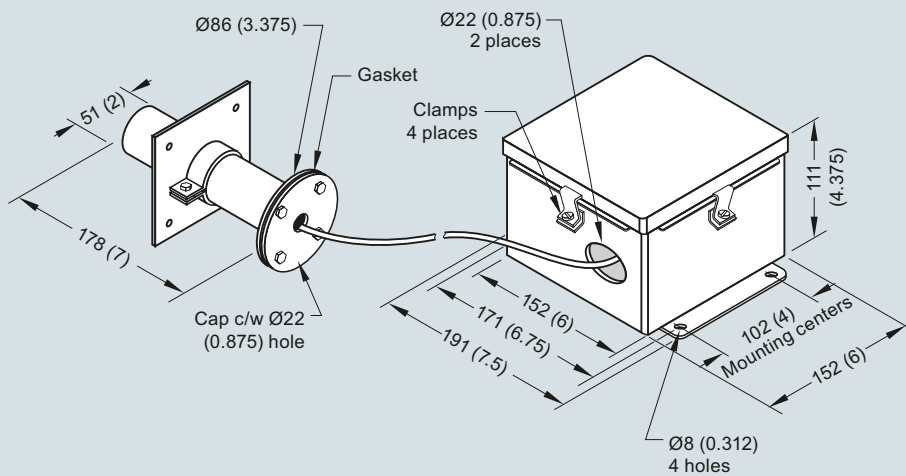

Milltronics probes, dimensions in mm (inch)

### Overview



Milltronics MSP-7 is a heavy-duty 3-wire motion sensor that provides an NPN open collector output to PLCs.

### Benefits

- Up to 100 mm (4 inch) gap between target and probe
- Corrosion resistant construction
- General purpose, suitable for majority of industrial applications; rugged probe designs provide unmatched reliability

### Application

The MSP-7 motion sensing probe can detect changes in the rotation and movement of ferrous equipment. When connected to a PLC it can warn of malfunction and signals to stop or slow down equipment, preventing costly failure or downtime. Its reliability makes it a very cost effective sensor.

The single setpoint system suits most industrial applications. This versatile unit can be used on tail pulley shafts, driven pulleys, motor shaft sensing, belt or drag conveyors, screw conveyor flights, bucket elevators, fans and pumps.

An NPN open collector 3-wire output allows for versatile connection to most PLC models and a large dynamic range ensures that the MSP-7 can detect changes in target speed for a variety of applications.

- Key Applications: tail pulleys, motor shaft sensing, screw conveyor flights, bucket elevators

### Design

#### Mounting for Milltronics MSP-7

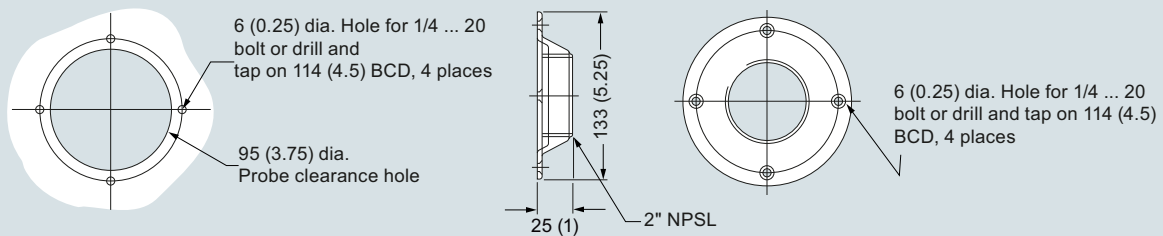

**Note:** Mounting flange supplied with probe.

Mounting for Milltronics MSP-7, dimensions in mm (inch)

### Technical specifications

<b>Mode of operation</b>	
Measuring principle	Magnetic
Typical application	Monitoring loss of motion in tail pulley, screw flights, bucket elevators
<b>Features</b>	
	<ul style="list-style-type: none"> <li>• Rugged corrosion resistant aluminum body</li> <li>• Low voltage operation</li> <li>• Large dynamic range</li> <li>• Threaded body for finite adjustment</li> </ul>
<b>Output</b>	
	NPN open collector, 2 k $\Omega$ pull up to input voltage, 330 $\Omega$ impedance, 40 mA max.
<b>Performance</b>	
Repeatability	$\pm 1\%$
Dead band	$\pm 0.25\%$
<b>Dynamic Range</b>	
	0 ... 7 200 PPM
<b>Ambient Temperature Range</b>	
	-40 ... +60 °C (-40 ... +140 °F)
<b>Storage temperature</b>	
	-40 ... +60 °C (-40 ... +140 °F)
<b>Design</b>	
Enclosure rating	Type 4X/NEMA 4X/IP67
<b>Power Supply</b>	
	21 ... 28 V DC, 40 mA max.
<b>Certificates and approvals</b>	
	CE, RCM, EAC, KCC

## Process Protection

### Motion sensors

#### Milltronics MSP-7 Motion sensor

##### Selection and ordering data

###### Milltronics Motion sensing probes

Heavy duty, 100 mm measuring range, for use with RMA, MFA 4p, WM300 MFA, or other control.

➤ Click on the Article No. for the online configuration in the PIA Life Cycle Portal.

###### Cable Length

Standard length (as described in Model options)<sup>1)</sup>

Add Order code Y01 and plain text:

"Total cable length ... m"

Extended cable length 2 ... 30 m (6.6 ... 98.4 ft)

###### Model [standard cable length/type]

MSP-7, 1/2" NPT cable inlet [1.5 m (5 ft) cable]

###### Approvals

CE, RCM, EAC, KCC

<sup>1)</sup> No Y01 needed in Order code for standard length.

##### Article No.

7MH7146-

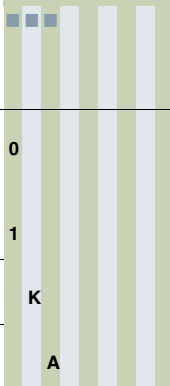

##### Selection and ordering data

###### Further designs

Please add "-Z" to Article No. and specify Order code(s).

Total cable length: enter the total cable length in plain text description

Acrylic coated, stainless steel tag

[13 x 45 mm (0.5 x 1.75 inch)]:

Measuring-point number/identification (max. 16 characters), specify in plain text

Cable gland kit

Manufacturer's test certificate:

According to EN 10204-2.2

###### Operating Instructions

All literature is available to download for free, in a range of languages, at

<http://www.siemens.com/processinstrumentation/documentation>

###### Spare Parts

Locknut, for MSP-3, MSP-7, MSP-12, XPP-5

Mounting flange, for MSP-3, MSP-7, MSP-12, XPP-5

Lid, 1/2" NPT cable inlet for MSP-3, MSP-7, MSP-12

Lid gasket, for MSP-7, MSP-12

Motion cable gland adaptor kit

##### Order code

Y01

Y17

A57

C11

##### Article No.

7MH7723-1CR

7MH7723-1CS

7MH7723-1CU

7MH7723-1CX

7MH7723-1JU

6

#### Dimensional drawings

Stand-alone probe Milltronics MSP-7

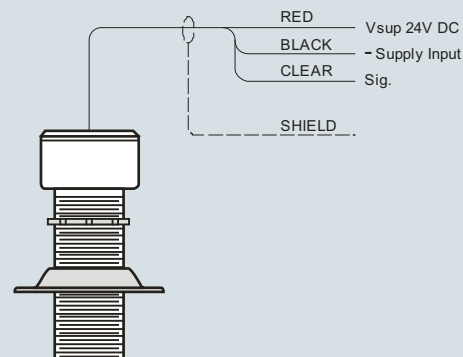
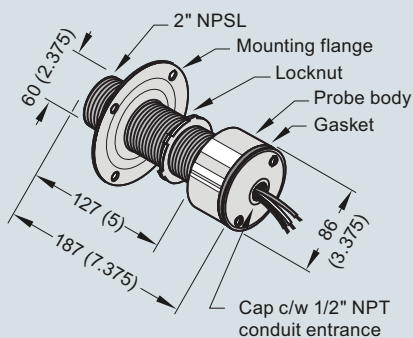

Stand-alone probe Milltronics MSP-7, dimensions in mm (inch)

#### SITRANS WM300 Motion failure alarm controller

### Overview



SITRANS WM300 MFA motion failure alarm controller is a highly sensitive dual setpoint motion sensor system, used with Milltronics MSP probes.

### Benefits

- Up to 100 mm (4 inch) gap between target and probe.
- Over and under speed setpoint detection.
- Setpoint adjustment range 2 to 5 000 Hz (120 to 300 000 ppm).
- Adjustable start-up time delay.
- Visual indication of probe operation and relay status.
- General purpose, suitable for majority of industrial applications; rugged probe designs provide unmatched reliability.

### Application

The SITRANS WM300 MFA detects changes in the motion and speed of rotating, reciprocating or conveying equipment. It warns of equipment malfunction and signals through contacts to shut down machinery in case of a slowdown or failure. Its reliability makes it a cost-effective way to protect valuable process equipment.

The dual setpoint system suits most industrial applications. This versatile unit can be used on tail pulley shafts, driven pulleys, motor shaft sensing, belt or drag conveyors, screw conveyor flights, bucket elevators, fans and pumps.

Multiple machines can be monitored with twin, independent probe inputs as well as an additional 2 inputs for differential speed detection (DSD) within a machine monitoring solution such as a belt conveyor comparing the head to tail pulley speeds. An optional analog output module can convert the WM300 into a non-contacting tachometer (NCT) with 2 mA outputs.

A special feature is the adjustable 0 to 60 second time delay, allowing the monitored device to accelerate to normal running speed before monitoring begins. A wide range of probes are available to suit specific needs, including high temperatures and corrosive installations. SITRANS WM300 MFA consistently meets the needs of mining aggregate, cement and other primary and secondary industries.

- Key Applications: tail pulleys, motor shaft sensing, screw conveyor flights, bucket elevators

## Process Protection

### Motion sensors

#### SITRANS WM300 Motion failure alarm controller

#### Design

##### Mounting for Milltronics MSP-3, MSP-7, MSP-12, XPP-5

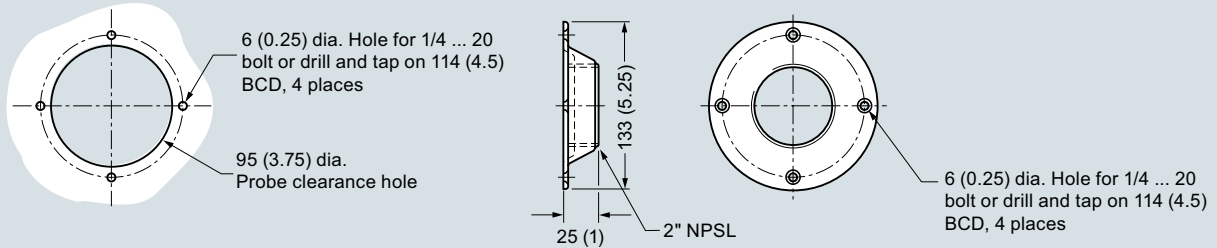

**Note:** Mounting flange supplied with probe.

##### Mounting for Milltronics MSP-9

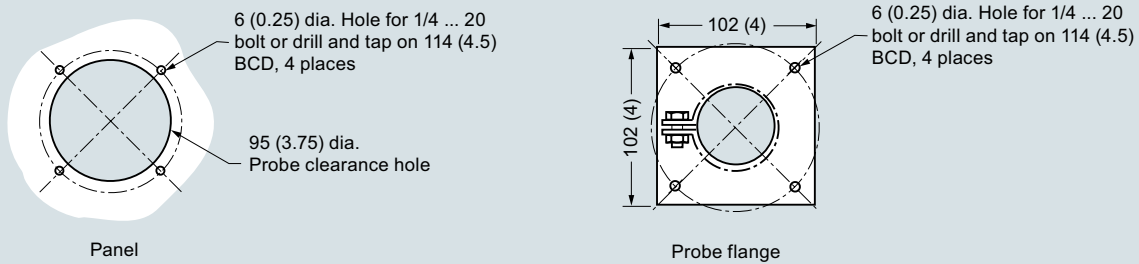

Milltronics MSP-12, MSP-3, MSP-7, MSP-9, XPP-5 mounting, dimensions in mm (inch)

##### Standard Milltronics MSP-12



- Heavy-duty general purpose motion probe
- Long lasting aluminum body with internal amplifier
- Convenient mounting flange and locknut for fast installation and setup
- Temperature rating: -40 ... +60 °C (-40 ... +140 °F)
- Enclosure rating: Type/NEMA 4X, 6, IP67

##### Standard Milltronics MSP-7



- Heavy-duty general purpose motion probe for direct connection to WM300 MFA
- Long lasting aluminum body
- Convenient mounting flange and locknut for fast installation and setup
- Temperature rating: -40 ... +60 °C (-40 ... +140 °F)
- Enclosure rating: Type/NEMA 4X, 6, IP67
- NPN, open collector output
- 24 V DC power supply

##### Milltronics XPP-5



- CSA hazardous approval (Class I, Div. 1, Groups A, B, C, D; Class II Div. 1, Groups E, F, G; Class III)
- Aluminum body that is fully potted
- Convenient mounting flange and locknut
- 3/4" NPT male hub connection
- Operating temperature from -40 ... 60 °C (-40 ... 140 °F)
- Enclosure rating: Type/NEMA 4X, 6, IP67

##### High temperature Milltronics MSP-3



- Heavy-duty, high temperature aluminum probe designed to withstand operating temperatures from -50 ... 260 °C (500 °F)
- Cast aluminum probe with convenient mounting flange and locknut
- 1.5 m (5 ft) of high temperature PTFE cable provided. Up to 30 m (100 ft) may be used.
- Enclosure rating: Type/NEMA 4X, 6, IP67

##### Stainless high temperature Milltronics MSP-9



- Heavy-duty, high temperature 304 stainless steel probe
- Special construction allows operation of probe in environment from -50 ... 260 °C (500 °F)
- 1.5 m (5 ft) special high temperature PTFE cable provided. Up to 30 m (100 ft) may be used.
- Enclosure rating: Type/NEMA 4X, 6, IP67

##### Milltronics RMA (Remote Mounted Amplifier)



- Available for internal mounted IMA in probe, or without and converting older existing applications into 3-wire NPN signals for use with WM300 MFA
- DIN rail mount
- Operating temp. from -40 ... +60 °C (-40 ... +140 °F)

Milltronics motion probes

**SITRANS WM300 Motion failure alarm controller**

Technical specifications		Selection and ordering data	Article No.
<b>Mode of operation</b>		<b>Motion Failure Alarm MFA, DSD, NCT</b>	<b>7MH7701-0AA00-0A</b>
Measuring principle	Motion monitor and alarm	A highly sensitive dual setpoint motion sensor system, used with up to 2 MSP or XPP probes. Capable of hi/lo setpoint as well as differential monitoring with 2 additional probes.	
Typical application	Monitoring loss of motion in tail pulley, screw flights, bucket elevators		
<b>Features</b>		<b>Remote Mounted Amplifier RMA</b>	<b>7MH7702-0B</b>
	<ul style="list-style-type: none"> <li>Switch user configurable overspeed and underspeed detection</li> <li>Adjustable start-up time delay: 0 ... 60 seconds</li> <li>Visual indication of probe operation and relay status</li> <li>Setpoint adjustment range:               <ul style="list-style-type: none"> <li>Standard model: 2 ... 5 000 Hz (120 ... 300 000 ppm)</li> <li>Slow speed version: 2 ... 400 seconds (30 ... 0.15 ppm)</li> </ul> </li> <li>Adjustable start-up time delay: 0 ... 60 seconds</li> <li>Visual indication of probe operation and relay status</li> </ul>	Remote mounted amplifier for 2 Milltronics MSP-1, MSP-3, MSP-9, MSP-12 and XPP-5 motion sensing probes.	
<b>Output</b>		<b>Analog output module NCT</b>	<b>6ED10551MM000BA2</b>
Resistive rating	4 relays	Additional module required for NCT applications featuring 2, 4 ... 20 mA outputs, used with WM300.	
	<ul style="list-style-type: none"> <li>10 A at 24 V DC</li> <li>10 A at 240 V AC</li> </ul>	<b>Power conversion module</b>	<b>6EP13311SH03</b>
<b>Performance</b>		Convert 100 ... 240 V AC ... 24 V DC power, for use with WM300	
Repeatability	± 1 %	<b>Remote display and configuration panel</b>	<b>6ED10554MH080BA0</b>
Dead band	± 0.25 %	Larger text display panel mount HMI for use with enclosure mounted WM300 for easy user access and monitoring.	
<b>MSP and XPP dynamic range</b>	0 ... 7 200 PPM	<i>Operating Instructions</i>	
<b>Ambient temperature range</b>	-20 ... +50 °C (-5 ... +122 °F)	All literature is available to download for free, in a range of languages, at <a href="http://www.siemens.com/processinstrumentation/documentation">http://www.siemens.com/processinstrumentation/documentation</a>	
<b>Storage temperature</b>	-20 ... +50 °C (-5 ... +122 °F)		
<b>Design</b>			
Enclosure dimensions	71.5 x 90 x 60 mm (2.8 x 3.5 x 2.4 inch)		
Enclosure material	Polycarbonate		
<b>Power</b>			
	<ul style="list-style-type: none"> <li>10.8 ... 28.8 V DC, 25 ... 165 mA</li> <li>Power supply: 100 ... 240 V AC, 50/60 Hz, 0.7 ... 0.35 A per LOGO! power module</li> </ul>		
<b>Certificates and approvals</b>			
	CE, CSA/ULC/US, FM, EAC, RCM, KCC		

# Process Protection

## Motion sensors

### SITRANS WM300 Motion failure alarm controller

#### Dimensional drawings

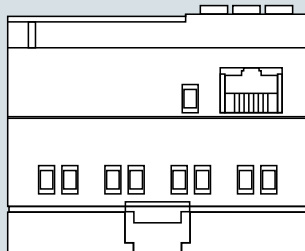
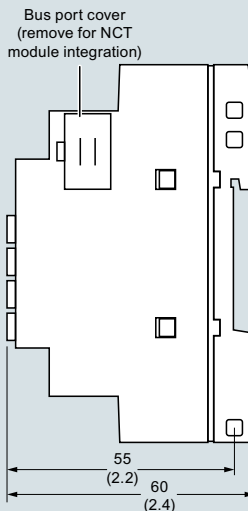
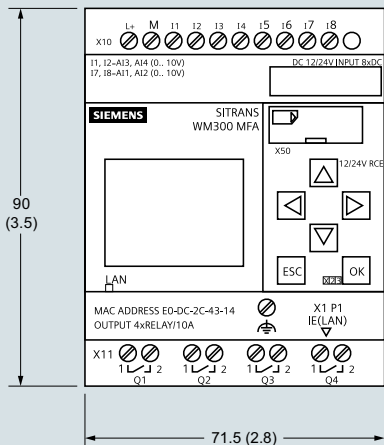

Standard Probe MSP-7, MSP-12

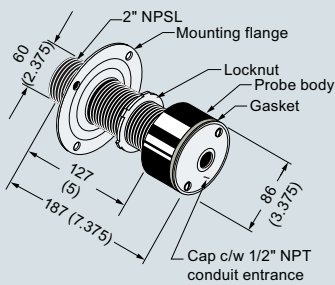

Hazardous Locations XPP-5

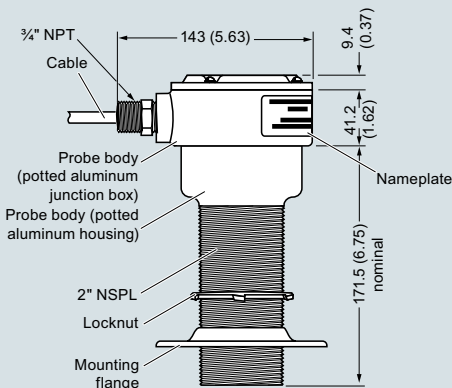

SITRANS WM300 MFA and probe, dimensions in mm (inch)

High temperature probe MSP-3

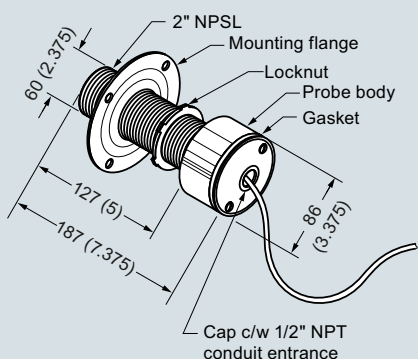

High temperature stainless steel probe MSP-9

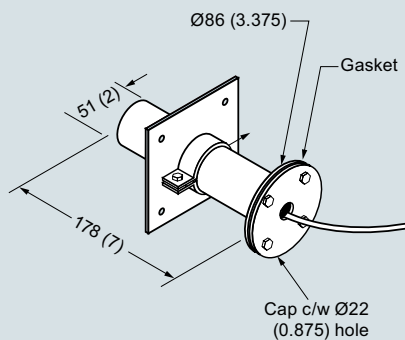

Milltronics probes, dimensions in mm (inch)

## Overview



SITRANS WM100 is a heavy-duty zero-speed alarm switch. This non-contacting unit provides cost-effective equipment protection even in the harshest conditions.

## Benefits

- Up to 100 mm (4 inch) gap between SITRANS WM100 and targets
- Rugged, low maintenance suitable for tough environments
- 1 SPDT Form C relay contact
- Provides cost-effective protection
- Visual indication of target triggered pulse

## Application

This rugged unit is impervious to dust, dirt, build-up and moisture and is ideal for such primary industries as mining, aggregate, and cement. Operating where other systems are prone to failure, the non-contacting design eliminates the need for lubricating, cleaning and part replacement. Downtime and clean-up expenses associated with conveying equipment failure are reduced by the SITRANS WM100. It alarms to minimize spillage, prevent extensive damage or even fire caused by belt slippage at the head pulley, and warns against conveyor malfunction.

The SITRANS WM100 has built-in selectable start delays and 1 Form C relay contact. With an aluminum body, it operates from -40 to +60 °C (-40 to +140 °F).

- Key Applications: tail pulleys, driven pulleys, motor shaft sensing, screw conveyor flights, bucket elevators

## Design

### Mounting

The WM100 probe should be mounted, using the supplied mounting flange, onto a vibration-free structure. The gap between the probe and the target should be sufficient such that there is no danger of the target damaging the probe. The maximum allowable gap is 100 mm (4 inch) from the face of the target to the face of the probe for 4.5 x 4.5 mm (3/16 x 3/16 inch) keyway. The WM100 is sensitive to lateral disturbances to its magnetic field. If the WM100 is responding to motion from an interfering target, move the WM100 or install a ferrous plate (steel) as a shield between the WM100 and the interfering target. Where possible, the probe should be mounted such that the cable inlet is pointing downward to avoid accumulation of condensation in the casing. Connection of the probe should be made via flexible conduit for easier removal or adjustment of the probe.

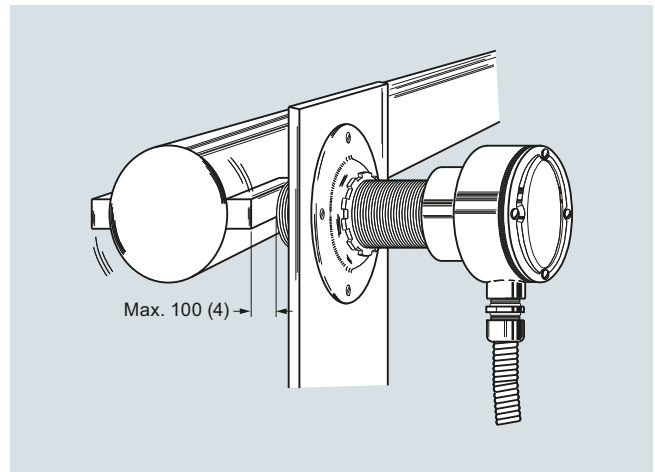

SITRANS WM100 mounting, dimensions in mm (inch)

## Process Protection

### Motion sensors

#### SITRANS WM100 Motion sensor

##### Technical specifications

Mode of operation	
Measuring principle	Disruption of magnetic field by ferrous target
Typical application	Monitors absence or presence of motion in harsh conditions
Output	
Contact	1 SPDT Form C dry relay contact, rated 5 A at 250 V AC, fail-safe operation
Time delay	Start up: 10 ... 14 seconds (5 ... 7 seconds with 12 ppm jumper installed)
Zero Speed (selected via a common jumper)	5 seconds ± 1 (minimum speed 10 ... 15 ppm) or 10 seconds ± 2 (minimum speed 5 ... 7.5 ppm)
Rated operating conditions	
Operating temperature	-40 ... +60 °C (-40 ... +140 °F)
Storage temperature	-40 ... +60 °C (-40 ... +140 °F)
Design	
Probe body	Aluminum
Process mounting	2" NPSL
Connection box	Aluminum, ¾" NPT conduit entrance, 5 screw terminals plus grounding terminal for electrical connection, max. 12 AWG (3.30 mm <sup>2</sup> ) wire size
Gasketing	Neoprene
Display	Red LED for verification of pulses
Enclosure rating	Type NEMA 4x, 6, IP67
Dynamic range	
	Minimum 6 or 12 pulses per minute Maximum 3 000 pulses per minute
Shipping weight	
	2 kg (4.4 lb)
Power supply	
	<ul style="list-style-type: none"> <li>• 115 V AC/50 ... 60 Hz, 7 VA</li> <li>• 230 V AC/50 ... 60 Hz, 7 VA</li> <li>• ± 10 % of rated voltage</li> </ul>
Certificates and approvals	
	CSA <sub>US/C</sub> , CE, RCM, EAC, KCC

##### Selection and ordering data

SITRANS WM100 Motion sensor		Article No.
Heavy duty speed alarm switch with 100 mm measuring range.		7MH7158 -
<a href="#">Click on the Article No. for the online configuration in the PIA Life Cycle Portal.</a>		0 A 0 0
Model		A
115 V AC		B
230 V AC		
Further designs		Order code
Please add "-Z" to Article No. and specify Order code(s).		C11
Manufacturer's Test Certificate: According to EN 10204-2.2		Y17
Acrylic coated, stainless steel tag [13 x 45 mm (0.5 x 1.75 inch)]; Measuring-point number/i-identification (max. 16 characters), specify in plain text		
Operating Instructions		
All literature is available to download for free, in a range of languages, at <a href="http://www.siemens.com/processinstrumentation/documentation">http://www.siemens.com/processinstrumentation/documentation</a>		
Accessories		Article No.
Locknut		7MH723-1CR
Mounting flange		7MH723-1CS
Motion cable gland adaptor kit		7MH723-1JU

**Dimensional drawings**

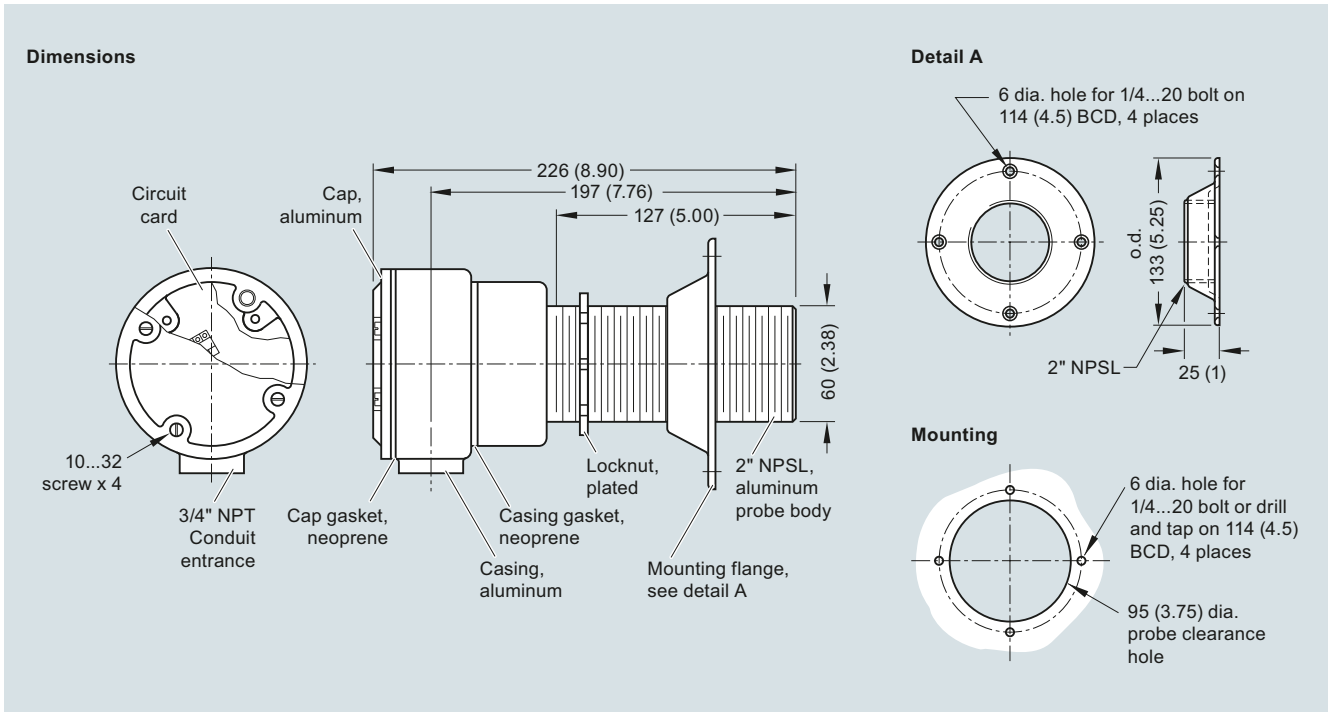

SITRANS WM100 mounting, dimensions in mm (inch)

## Process Protection

### Motion sensors

#### SITRANS WM100 Motion sensor

#### Circuit diagrams

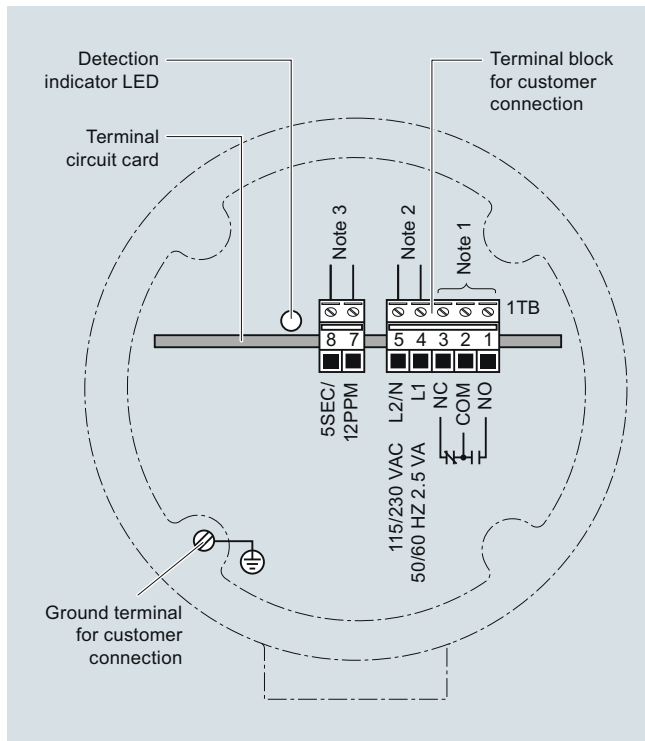

SITRANS WM100 wiring

#### Notes:

1. Dry contacts shown in de-energized (alarm or shelf) state.
2. SITRANS WM100 is manufactured for either 115 or 230 V AC operation. Check WM100 nameplate for applicable voltage. Correct voltage must be supplied. Voltages lower than specified will result in an inoperative condition. Voltages higher than specified will severely damage unit.
3. For 5 second time delay and a minimum 12 ppm range, connect jumper across terminals 7 and 8. Without a jumper, the default is a 10 second time delay and a minimum 6 ppm range.