

## 8US Busbar Systems

### Fast Bus

- 16/1 General ratings
- 16/2 Introduction
- 16/3 60 mm system
- 16/4 Circuit breaker kits
- 16/5 Busbar adapters and device holders
- 16/6 Terminals and accessories

## 3RA61 Compact Starters

- 16/7 3RA61 direct-on-line starters
- 16/8 3RA62 reversing starters
- 16/9 Accessories for 3RA6 direct-on-line and reversing starters
- 16/11 Infeed systems for 3RA6

## Overview

### General Ratings of Fastbus System

	IEC	Domestic
Rated operating voltage	690V	600V
Rated insulation voltage, IEC VDE	AC 1000V	N/A
Temperature stability	Up to 105 degrees C	N/A
Busbar support and adapter shoe material	Glass-reinforced polyamide	Same
Color	RAL 7035, light gray	Same

### Ampacity

#### Three single stack busbars

5 x 20 mm	3/16" x 3/4"	362A
5 x 25 mm	3/16" x 1"	432A
5 x 30 mm	3/16" x 1 1/8"	500A

#### Three double stacked busbars

10 x 20 mm	3/8" x 3/4"	564A
10 x 25 mm	3/8" x 1"	660A
10 x 30 mm	3/8" x 1 1/8"	756A

For technical information on E and F frame circuit breakers used as main and feeder breakers, see section 17

*Thermal busbar currents, E-Cu, bare, at 35 °C ambient temperature in accordance with DIN 43 6711*

Busbar dimensions	System	Thermal current at		
		65 °C Busbar temperature A	85 °C A	105 °C A
mm	mm			
20 x 5	60	274	362	430
25 x 5	60	327	432	513
30 x 5	60	379	500	595
20 x 10	60	427	564	670
30 x 10	60	573	756	900

### Fast Bus set-up

The Fast Bus system is designed to be easy to use and to save set up time.

#### 8US Busbar holders

Because the 8US Busbar holders are adjustable, they can be used with a number of different busbar sizes allowing you to standardize on one style of busbar holder for busbars with a width and thickness of 20 mm x 5 mm up to 30 mm x 10 mm thus providing a wide range of current carrying capability.

#### High quality material

Busbar supports and fuse bases are manufactured from glass-fiber reinforced, thermoplastic polyester with the color RAL 7035, light gray. The material ensures excellent mechanical, chemical and electrical properties. Furthermore, the material has an extremely low flammability and meets the requirements of UL 94 V0.

#### 8WC Busbar and busbar systems

The most common size busbar for applications in the US is the 8WC5053 (20 mm x 5 mm), however there are other styles available depending on your application.

Busbar systems with 60 mm busbar center-to-center clearance have now become firmly estab-

lished in the US market.

The permissible busbar temperature is a decisive factor when dimensioning the busbars. The busbar temperature is dependent on the current, the current distribution, the busbar cross-section, the busbar surface, the position of the busbar, the convection and the ambient temperature. The values stated in the table on page 5/3 can only be considered as reference values because the conditions vary with each location. The values are based on constant current over the whole busbar length.

The trend toward busbars proves most advantageous when the incoming supply is centrally located and the load is distributed symmetrically on both sides.

For the assemblies of a busbar system in the feeder circuit the UL directives specify components with large clearance in air and creepage distances (see the table below). Components of the 8US1 busbar system which meet this requirement can be found in this chapter.

*Note:  
The design of an 8US1 busbar system for use in the feeder circuit always presumes the use of the UL base plate (8US19 22-2UA01) so that the clearance in air and creepage distance requirements are met.*

### Feeder/branch circuit according to UL 508A

The feeder circuit is that part of a circuit which comes in front of the last short circuit protection device (SCPD). The branch circuit is that part of the circuit which follows after the last short circuit protection device. When the 8US1 busbar system is used in a switchgear which must comply with UL directives, it is important to establish whether it is to be used in the feeder circuit or the branch circuit. Components used in the feeder circuit require larger clearance in air and creepage distances than in the branch circuit.

#### Simple Fast Bus system

The two illustrations above show the very basic items needed when setting up a Fastbus system.

- ① 8US1 Busbar holder (5/6)
- ② 8US1 Ground busbar support (shown attached however can be mounted separately 5/6)
- ③ Ground busbar 6 mm x 6 mm also available in 5 x 20 mm to 10 x 30 mm
- ④ 8WC Busbar (8WC5053 shown) FBB36 Busbar (5/6)

### Short-circuit strength

The short-circuit strength of the busbar system is dependent on the spacing of the busbar holders and on the busbar cross-section.

The short-circuit strength of the whole system is dependent on the short-circuit strength of the busbars and of the adapters with circuit protection.

### Applications

The 8US Fast Bus distribution system is ideal for control panel builders with multiple motor applications. These applications are most common in the material handling, automotive, food processing, pharmaceutical and paper processing industries.

	Clearance in air	Creepage distance
Between live parts	25.4 mm (1 inch)	50.8 mm (2 inch)
Between live parts and grounded, non-insulated metal parts	25.4 mm (1 inch)	25.4 mm (1 inch)

### Fast Bus combination starters and group installation assemblies

#### Ratings for Group Installations per NEC 430-53

Group Installation is an approach to building multiple motor control systems in accordance with Section 430-53 of the National Electrical Code. In Group installation, multiple motor starters can be grouped under one short circuit protective device. The 3RV MSP's have been UL listed for use in Group Installations both with and without 3RT contactors when mounted on the Fast Bus system. A 3RT contactor is added when remote operation of the motor is required.

#### Standard Installation, NEC 430-52

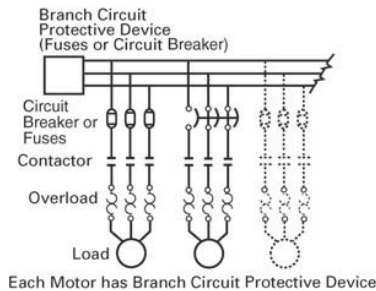

#### Group Installation, NEC 430-53

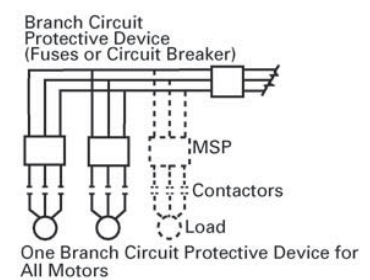

MSP Type	Through FLA range Amps	Maximum rating of Group Branch Circuit Protective Device		Short Circuit Current Ratings	
		Fuse	Circuit Breaker	480V	575V
3RV101	0, 11-12	The main fuse should be selected based on the FUSE selection procedure listed below.	The main CB should be selected based on the CIRCUIT BREAKER selection procedure listed below.	65kA	10kA
3RV102	0, 11-12.5			65kA	30kA
3RV102	11-25			65kA	10kA
3RV103	11-50			65kA	30kA
3RV104	28-100			65kA	30kA

#### The selection of components for Group Installation is a simple process of the following three steps:

1. Selection of the Branch Circuit Protective Device, fuse or circuit breaker.
2. Selection of the Motor Starter protector based on the motor Full Load Amps.
3. Selection of the 3RT contactor based on the HP and voltage rating of the motor.

#### Circuit Breaker Selection

Select a circuit breaker (CB) between:  
 Minimum CB size (per NEC430-110):  
 Sum of all motor FLC (per NEC table 430-150) x 115%.  
 Maximum CB size (per NEC430-53c):  
 250% x FLC of the largest motor + FLC of all other motors.

#### Fuse Selection

Calculate the maximum fuse size per NEC430-53c.  
 Max Fuse Size = 175% x FLC of largest motor + FLC of all other motors (FLC's from NEC table 430-150).

MSP Type	MSP Size	Through FLA range Amps	Short Circuit Current Ratings (Type E) <sup>1)</sup>		
			240V	480Y/277V	600Y/347V
3RV102	S0	0, 11-12	65kA	65kA	30kA
3RV103	S2	11-50	65kA	65kA	25kA
3RV104	S3	28-100	65kA	65kA	30kA (up to 75A)

<sup>1)</sup> MSP sizes S0 and S3 require additional terminal kits for type E applications. See section 1

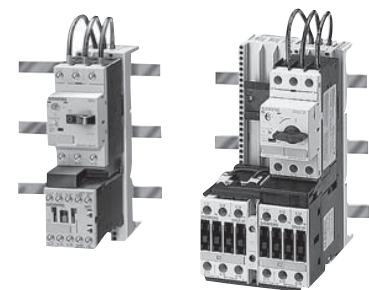

# Fast Bus Fast Bus Busbar Adapter System







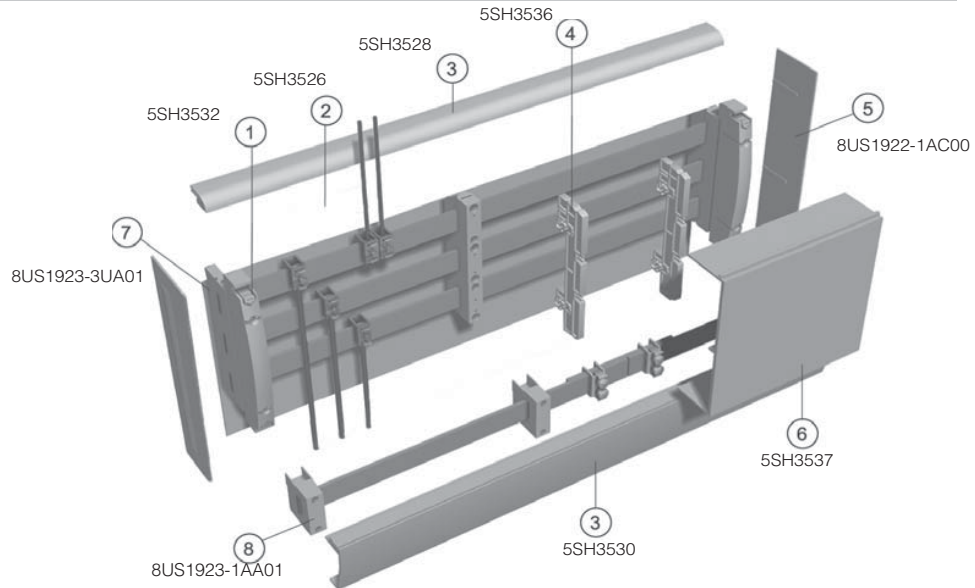

60 mm system

## Selection and ordering data

for sharp-edged copper busbars to DIN 46 433, width 20 mm to 30 mm, thickness 5 mm and 10 mm

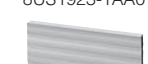
- ① Holder for end cover and edge profile
- ② Base plate
- ③ Edge profile
- ④ Holder for Reserve Space Cover
- ⑤ End cover
- ⑥ Reserve Space Cover
- ⑦ Busbar holder, 3-phase
- ⑧ Ground busbar holder



	Description	UL Current rating	UL508A Compliance <sup>1)</sup>	Order No.	Pack Units
	<b>Base plate ②</b>				
8US1922-2UA01	3-pole system flat 230 mm x 1100 mm	-	required	<b>8US19 22-2UA01</b>	
	<b>Copper Busbar (flat copper bars with tin plating)</b>				
8WC5	20 mm x 5 mm x 914 mm (36") for 60 mm systems	362A	yes	<b>FBB36</b>	3 pcs
	20 mm x 5 mm x 1524 mm (60") for 60 mm systems	362A	yes	<b>FBB60</b>	3 pcs
	20 mm x 5 mm x 2000 mm (78.74") for 60 mm systems	362A	yes	<b>8WC5053</b>	
8US1948-2AA00	25 mm x 5 mm x 2000 mm (78.74") for 60 mm systems	432A	yes	<b>8WC5054</b>	
	30 mm x 5 mm x 2000 mm (78.74") for 60 mm systems	500A	yes	<b>8WC5055</b>	
	20 mm x 10 mm x 2000 mm for 60 mm systems	564A	yes	<b>8WC5063</b>	
	30 mm x 10 mm x 2000 mm for 60 mm systems	756A	yes	<b>8WC5065</b>	
	720 mm <sup>2</sup> x 2400 mm (94.49") Twin T (TT) Busbar	1400A	yes	<b>8US19 48-2AA00</b>	
	<b>Busbar holder (end and intermediate) ⑦</b>				
8US1922-1AC00	3-pole with inside mounting for 20 mm - 30 mm x 5 mm or 10 mm -	-	yes	<b>8US19 23-3UA01</b>	
8US1923-3UA01	3-pole with inside mounting for Twin T (TT) w/ end cover	-	yes	<b>8US19 43-3AA00</b>	
	<b>Busbar holder end cover ⑤</b>				
	3-pole end cover fits 8US19 23-3UA01	-	required	<b>8US19 22-1AC00</b>	
	<b>Ground Busbar holder ⑧</b>				
8US1923-1AA01	1-pole with inside mounting for 20 mm - 30 mm x 5 mm or 10 mm <sup>2)</sup> also for 6 mm x 6 mm	135A	n/a	<b>8US19 23-1AA01</b>	
	<b>Cover profiles for Busbars</b>				
	for 5 mm busbars up to 30 mm wide 1100 mm length	-	required	<b>8US19 22-2AA00</b>	
	for 10 mm busbars up to 30 mm 1100 mm length	-	required	<b>8US19 22-2BA00</b>	
8US1922-2AA00	for Twin T (TT) busbar 1000 mm length	-	required	<b>8US19 22-2DA00</b>	
	<b>Reserve space cover ④⑥</b>				
	holder for the Reserve Space Cover for 60 mm systems	-	required	<b>5SH3536</b>	4 pcs
	Reserve Space Cover 1000 mm length	-	required	<b>5SH3537</b>	
	<b>Infeed for feeder circuit (accepts all busbar sizes on this page)</b>				
5SH3538	3-pole terminal plate with cover 20 mm x 200 mm 16-4 AWG	80A	yes	<b>5SH3538</b>	
8US1921-1BA00	3-pole terminal plate with cover 54 mm x 200 mm 10-2/0 AWG	300A	yes	<b>8US19 21-1BA00</b>	
	3-pole terminal plate with cover 81 mm x 200 mm 2 AWG-250 MCM	440A	yes	<b>8US19 21-1AA00</b>	
	3-pole terminal plate with cover 180 mm x 200 mm 250-600 MCM	560A	yes	<b>FBT600F</b>	
	3-pole terminal plate 154 mm x 184 mm 300-600 MCM	560A	yes	<b>8US19 41-2AA03</b>	
	3-pole terminal plate 160 mm x 184 mm for flat bars up to 32 mm x 20 mm	800A	yes	<b>8US19 41-2AA04</b>	
FBT600F w/cover	cover for 8US19 41-2AA03 and 04 180 mm x 200 mm x 90 mm	-	yes	<b>8US19 22-1GC00</b>	

<sup>1)</sup> UL 508A labeled panels require the use of components that meet the creepage and air distances of 1" air clearance and 2" creepage distance. N/A = not applicable for given item.

<sup>2)</sup> Current rating dependent on size of busbar used. Refer to busbar selection data.

# Fast Bus Fast Bus Busbar Adapter System

60 mm system  
Circuit breaker kits

## Selection and ordering data

Description

### FBCB Fast Bus circuit breakers

Offer a full range of circuit breakers from 15A to 250A. All kits 90A and under are pre-assembled on 60 mm Fast Bus adaptor shoes and ready to place on the busbar. Circuit breakers

100A and higher are pre-packaged for fast assembly and must be torqued down to the busbar.  
A full range of main circuit breakers from 50A to 250A come in pre-

packaged kits that include the circuit breaker, Fast Bus adapter with mounting plate and mounting hardware.





Design	UL Current rating	UL SCCR <sup>1)</sup>	Breaker frame	Order No.	Pack units
<b>Circuit breakers</b>					
 <p>FBCB030</p> <p>Feeder 3 pole/600V with Fast Bus "snap on" adapter shoes. Wires from shoe to breaker on the line side.</p>	15 amp	25kA	ED	<b>FBCB015</b>	
	20 amp	25kA	ED	<b>FBCB020</b>	
	25 amp	25kA	ED	<b>FBCB025</b>	
	30 amp	25kA	ED	<b>FBCB030</b>	
	35 amp	25kA	ED	<b>FBCB035</b>	
	40 amp	25kA	ED	<b>FBCB040</b>	
	45 amp	25kA	ED	<b>FBCB045</b>	
	50 amp	25kA	ED	<b>FBCB050</b>	
	60 amp	25kA	ED	<b>FBCB060</b>	
	70 amp	25kA	ED	<b>FBCB070</b>	
	80 amp	25kA	ED	<b>FBCB080</b>	
90 amp	25kA	ED	<b>FBCB090</b>		

# Fast Bus

## Fast Bus Busbar Adapter System

60 mm system  
Busbar adapters and device holders

### Selection and ordering data

Busbar device adapters	Number of mounting rails (35 mm)	Rated current	Connecting cables	Adapter length	Adapter width	Rated voltage UL	UL508A <sup>1)</sup> compliance	Order No.	Pack units	Weight per PU approx.
		A	AWG	mm	mm	V	kg			
<b>For SIRIUS</b>										
<b>Size S00/S0</b>										
 8US21 51-5DM07	MSP's	1	25	12	182	45	600	yes	<b>8US12 51-5DM07</b>	0.183
	Contactors + Overload relays	1	25	12	182	45	600	yes	<b>8US12 51-5DM07</b>	0.183
	Direct start load feeders	1	25	12	182	45	600	yes	<b>8US12 51-5DM07</b>	0.183
	Reversing feeders									
	Busbar adapters	1	25	12	182	45	600	yes	<b>8US12 51-5DM07</b>	0.183
	+ Device holders	1	--	--	182	45	600	yes	<b>8US12 50-5AM00</b>	0.158
	+ Connecting plates	--	--	--	--	--	--	yes	<b>8US19 98-1AA00</b>	100 units
<b>Size S00/S0 Cage Clamp</b>										
 8US21 60-5AM00	Direct start load feeders	1	12	14	182	45	600	yes	<b>8US12 51-5CM47</b>	0.190
<b>Size S2</b>										
 8US12 11-4TR00	MSP's	1	50	8	182	55	600	yes	<b>8US12 61-5FM08</b>	0.263
	Contactors + Overload relays	1	50	8	182	55	600	yes	<b>8US12 61-5FM08</b>	0.263
	Direct start load feeders	1	50	8	245	55	600	yes	<b>8US12 61-5FP08</b>	0.292
	Reversing feeders									
	Busbar adapters	1	50	8	242	55	600	yes	<b>8US12 61-5FP08</b>	0.292
	Busbar adapters	1	--	--	242	55	600	yes	<b>8US12 60-5AM00</b>	0.202
	+ Device holders	--	--	--	242	55	600	yes	<b>8US12 60-5AP00</b>	0.243
+ Connecting plates	--	--	--	--	--	--	yes	<b>8US19 98-1AA00</b>	100 units	0.100
<b>Size S3</b>										
		1	70	4	215	72	600	yes	<b>8US12 11-4TR00</b>	0.470
		1	100	--	200	72	600	yes	<b>FBS10072</b>	0.530
<b>For VL UL circuit breakers</b>										
 8US12 13-4AQ03	VL150 UL, DG frame	--	150	Tubular contacts	190	105	600	yes	<b>8US12 13-4AQ03</b>	1.020
	VL250 UL, FG frame	--	250	Tubular contacts	190	105	600	yes	<b>8US12 13-4AQ03</b>	1.020
 8US12 13-4AH00	VL400 UL, JG frame	--	400	Tubular contacts	296	140	600	yes	<b>8US12 13-4AH00</b>	1.900
	VL400X UL, LG frame	--	540	Tubular contacts	296	140	600	yes	<b>8US12 13-4AH00</b>	1.900











<sup>1)</sup> UL 508A labeled panels require the use of components that meet the creepage and air distances of 1" air clearance and 2" creepage distance.  
N/A = not applicable for given item.

# Fast Bus Fast Bus Busbar Adapter System

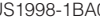
60 mm system  
Busbar adapters and device holders

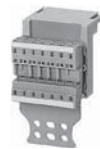
- 1
- 2
- 3
- 4
- 5
- 6
- 7
- 8
- 9
- 10
- 11
- 12
- 13
- 14
- 15
- 16
- 17

## Selection and ordering data

Description		Length	Width	UL508A Compliance <sup>1)</sup>	Order No.	Pack Units		
<b>Terminals for round conductors</b>								
<b>5 mm busbar thickness</b> for 20 mm x 5 mm to 30 mm x 5 mm								
	16 - 6 AWG	180 A		2)	<b>FBT166-1</b>	3		
	12 - 2 AWG	270 A		2)	<b>FBT122-1</b>	3		
	6 - 2/0 AWG	400 A		2)	<b>FBT620-1</b>	3		
	6 AWG - 250 MCM	440 A		2)	<b>FBT6250-1</b>	3		
	3/0 - 350 MCM	460 A		2)	<b>FBT30350</b>	3		
	300 - 600 MCM	560 A		2)	<b>FBT300600</b>	3		
<b>10 mm busbar thickness</b> for 20 mm x 10 mm to 30 mm x 10 mm								
	16 - 6 AWG	180 A		2)	<b>FBT166-2</b>	3		
	12 - 2 AWG	270 A		2)	<b>FBT122-2</b>	3		
	6 - 2/0 AWG	400 A		2)	<b>FBT620-2</b>	3		
	6 AWG - 250 MCM	440 A		2)	<b>FBT6250-2</b>	3		
	3/0 - 350 MCM	460 A		2)	<b>FBT30350</b>	3		
	300 - 600 MCM	560 A		2)	<b>FBT300600</b>	3		
<b>Covering cap for FBT terminals</b>								
	8US1922-1GA02	Attaches to busbar	90 mm depth	200 mm	135 mm	required	<b>FBC135</b>	
		Attaches to busbar	90 mm depth	200 mm	270 mm	required	<b>8US1922-1GA02</b>	
<b>Accessories for busbar adapters and device holders</b>								
		Mounting rail (35 mm) - plastic	45 mm			n/a	<b>8US1998-7CA15</b>	10
		complete with mounting screws	55 mm			n/a	<b>8US1998-7CA16</b>	10
			70 mm			n/a	<b>8US1998-4AA00</b>	10
			90 mm			n/a	<b>8US1998-7CA08</b>	10
			110 mm			n/a	<b>8US1998-7CA10</b>	10
		<b>Connection holder</b> (for vertical busbar assembly)	-			n/a	<b>8US1998-1DA00</b>	20
		fixes the MSP to the mounting rail <sup>3)</sup> (for SIRIUS sizes S00/S0)						
		<b>Screw holder</b>	-			n/a	<b>8US1998-1CA00</b>	20
		for supplementary screw fixing of the feeder (for SIRIUS sizes S00/S0)						
		<b>Spacer</b>	-			n/a	<b>8US1998-1BA00</b>	
		fixes the feeder to the busbar adapter (for SIRIUS sizes S00/S0)						
		<b>Connection wedges</b>	-			n/a	<b>FBC20</b>	20
		for mechanical linking of adapters and switching device holders (2 units required per combination)						
<b>Outgoing terminal rail for busbar adapters</b>								
		<b>Plug-type terminal</b>						
		(complete with supporting element for attaching to busbar adapter and switching device holder. Spring loaded terminals.)						
		3 x 14 AWG (400 V) and 4 x 16AWG (250 V)	91 mm	45 mm		n/a	<b>8US1998-8AM07</b>	
	7 x 14 AWG (400 V)	91 mm	54 mm		n/a	<b>8US1998-8AA10</b>		
<b>Accessories for busbar adapters and device holders</b>								
		Side module for busbar adapter expansion	For adapters w/182 mm	182 mm	10 mm	n/a	<b>8US1998-2BM00</b>	
		Side module for busbar adapter expansion	For adapters w/200 mm	200 mm	9 mm	n/a	<b>8US1998-2BJ10</b>	
<b>Accessories for busbar holder ①</b>								
		Top cover for 3-pole busbar holder when using Edge Profile				n/a	<b>5SH3532</b>	
		Side cover for 3-pole busbar holder when using Edge Profile				n/a	<b>5SH3533</b>	
<b>Edge Profile ③</b>								
		Solid for top profile	17 mm x 36 mm x 1100 mm			n/a	<b>5SH3528</b>	
		Solid for bottom profile	77 mm x 36 mm x 1100 mm			n/a	<b>5SH3530</b>	
		Slotted	17 mm x 86 mm x 1100 mm			n/a	<b>5SH3531</b>	

1) UL508A labeled panels require the use of components that meet the creepage and air distances of 1" air clearance and 2" creepage distance. N/A = not applicable for given item.  
 2) Terminals must be manually spaced on the busbar to comply with UL508A distances of 1" air clearance and 2" creepage distance.  
 3) For uses with 45 mm and 55 mm mounting rail.

# Compact Combination Starters

## 3RA6 Compact Starters

3RA61 direct-on-line starters  
up to 32 A

### Selection and ordering data



Direct start

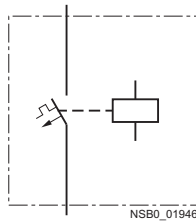

3RA61 20-1CB32

3RA61 20-2EB32

Standard induction motor 4-pole		Setting range for solid-state overload release 	Compact feeder	Weight per PU approx.  kg
480 V AC HP	600 V AC HP		Order No.	
-	-	0.1 ... 0.4	3RA61 20-□A□3□	1.3
1/2	1/2	0.32 ... 1.25	3RA61 20-□B□3□	1.3
2	3	1 ... 4	3RA61 20-□C□3□	1.3
7 1/2	10	3 ... 12	3RA61 20-□D□3□	1.3
20	30 <sup>(4)</sup>	8 ... 32	3RA61 20-□E□3□	1.3

#### Order No. supplement for connection type

- Without terminals  
for use with the infeed system for 3RA6 and the AS-i add-on module<sup>2)</sup>
- With screw terminals
- With spring-type terminals

#### Order No. supplement for rated control supply voltage

- 24 V AC/DC (required for use with AS-i add-on module<sup>2)</sup>)
- 42 ... 70 V AC/DC
- 110 ... 240 V AC/DC

#### Order No. supplement for mounting version

- For standard mounting rail or screw mounting<sup>3)</sup>:  
Basic version including 1 pair of main circuit terminals and 1 pair of control circuit terminals
- For use with the infeed system for 3RA6  
without main circuit terminals (with control circuit terminals)
- For standard mounting rail or screw mounting when using  
the AS-i add-on module<sup>2)</sup>  
without control circuit terminals (with main circuit terminals)



1) Selection depends on the specific startup and rated data of the protected motor.  
2) When specifying the AS-i version starter, the AS-i add-on module must be ordered separately. See page 4/10 for module options.  
3) A set of 3RA69 40-0A adapters is required for screw mounting.  
4) HP rating as manual starter only. Not applicable to type E.

# Compact Combination Starters

## 3RA6 Compact Starters

3RA62 reversing starters  
up to 32 A

### Selection and ordering data



Reversing duty

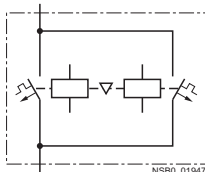

3RA62 50-1CP32

3RA62 50-2DP32

Standard induction motor 4-pole		Setting range for solid-state overload release 	Compact feeder		Weight per PU approx.  kg
480 V AC <sup>1)</sup> HP	600 V AC <sup>1)</sup> HP		Order No.	List Price \$ per PU	
-	-	A			
-	-	0.1 ... 0.4	<b>3RA62 50-□A□3□</b>		2.3
1/2	1/2	0.32 ... 1.25	<b>3RA62 50-□B□3□</b>		2.3
2	3	1 ... 4	<b>3RA62 50-□C□3□</b>		2.3
7 1/2	10	3 ... 12	<b>3RA62 50-□D□3□</b>		2.3
20	30	8 ... 32	<b>3RA62 50-□E□3□</b>		2.3

#### Order No. supplement for connection type

- Without terminals  
for use with the infeed system for 3RA6 and the AS-i add-on module<sup>2)</sup>
- With screw terminals
- With spring-type terminals

#### Order No. supplement for rated control supply voltage

- 24 V AC/DC (required for use with AS-i add-on module<sup>2)</sup>)
- 42 ... 70 V AC/DC
- 110 ... 240 V AC/DC

#### Order No. supplement for mounting version

- For standard mounting rail or screw mounting<sup>3)</sup>:  
Basic version including 1 pair of main circuit terminals and 1 pair of control circuit terminals
- For use with the infeed system for 3RA6  
without main circuit terminals (with control circuit terminals)
- For standard mounting rail or screw mounting when using  
the AS-i add-on module<sup>2)</sup>  
without control circuit terminals (with main circuit terminals)



<sup>1)</sup> Selection depends on the specific startup and rated data of the protected motor.

<sup>2)</sup> When specifying the AS-i version starter, the AS-i add-on module must be ordered separately. See page 4/10 for module options.

<sup>3)</sup> Two sets of 3RA69 40-0A adapters are required for screw mounting.

<sup>4)</sup> HP rating as manual starter only. Not applicable to type E.





# Compact Combination Starters

## 3RA6 Compact Starters

Accessories for 3RA6  
up to 32 A

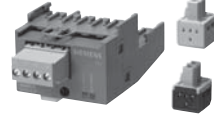
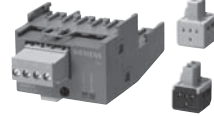
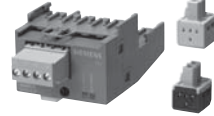
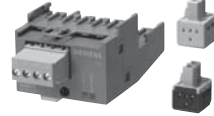
### Selection and ordering data

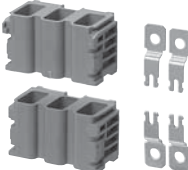
Type	Order No.	Weight per PU approx. kg
<b>Accessories specifically for 3RA6 compact starters</b>		
 <p>3RA69 70-3A</p> <p><b>AS-i add-on modules for compact starters</b> For communication of the compact starter with the control system using AS-Interface</p>	3RA69 70-3A <sup>1)</sup>	0.045
 <p>3RA69 70-3B</p> <p><b>AS-i add-on modules with two local inputs for safe disconnection</b></p>	3RA69 70-3B <sup>1)3)</sup>	0.045
 <p>3RA69 70-3B</p> <p><b>AS-i add-on modules with two free external inputs</b></p>	3RA69 70-3C <sup>1)</sup>	0.045
 <p>3RA69 70-3B</p> <p><b>AS-i add-on modules with one free external input and output each</b></p>	3RA69 70-3D <sup>1)</sup>	0.045
 <p>3RA69 70-3B</p> <p><b>AS-i add-on modules with two free external outputs</b></p>	3RA69 70-3E <sup>1)2)</sup>	0.045
 <p>3RK19 04-2AB01</p> <p><b>Addressing units for AS-i add-on modules</b></p> <ul style="list-style-type: none"> <li>• For active AS-Interface modules, intelligent sensors and actuators</li> <li>• According to AS-Interface Version 2.1</li> <li>• Including expanded addressing mode</li> <li>• Scope of supply           <ul style="list-style-type: none"> <li>- 1 addressing unit</li> <li>- 1 operating manual (English, French, German, Italian, Spanish)</li> <li>- 1 addressing cable (1.5 m, with jack plug)</li> </ul> </li> </ul>	3RK19 04-2AB01	0.540
 <p>3RA69 50-0A</p> <p><b>Control kit</b> For mechanical actuation of the compact starter</p>	3RA69 50-0A	0.004
 <p>3RA69 40-0A</p> <p><b>Adapters for screw mounting the compact starter</b> (set including push-in lugs) Direct-on-line starters require 1 set, reversing starters 2 sets.</p>	3RA69 40-0A	0.152

<sup>1)</sup> AS-i add-on modules may only be used with compact starters having 24 V coils.







<sup>2)</sup> For use with 3RA61 direct online starters only.

<sup>3)</sup> Rated for safety category 2 in accordance with EN ISO 13849-1.

# Compact Combination Starters

## 3RA6 Compact Starters

Accessories for 3RA6  
up to 32 A

Type	Version	Order No.	Weight per PU approx. kg
<b>Accessories specially for 3RA6 compact starters</b>			
		<b>Screw terminals</b> 	
 3RA6911-1A	<b>Auxiliary switch blocks for compact starters</b>		
	2 NO	<b>3RA69 11-1A</b>	0.018
	2 NC	<b>3RA69 12-1A</b>	0.018
	1 NO + 1 NC	<b>3RA69 13-1A</b>	0.018
 3RA6920-1A	<b>Main circuit terminals</b> (set for line and load)	<b>3RA69 20-1A</b>	0.038
	<b>Control circuit terminals</b> (set for direct starters)	<b>3RA69 20-1B</b>	0.042
	<b>Control circuit terminals</b> (set for reversing starters)	<b>3RA69 20-1C</b>	0.042
			<b>Spring-type connection</b> 
 3RA6911-2A	<b>Auxiliary switch blocks for compact starters</b>		
	2 NO	<b>3RA69 11-2A</b>	0.018
	2 NC	<b>3RA69 12-2A</b>	0.018
	1 NO + 1 NC	<b>3RA69 13-2A</b>	0.018
 3RA6920-2A	<b>Main circuit terminals</b> (set for line and load)	<b>3RA69 20-2A</b>	0.049
	<b>Control circuit terminals</b> (set for direct starters)	<b>3RA69 20-2B</b>	0.036
	<b>Control circuit terminals</b> (set for reversing starters)	<b>3RA69 20-2C</b>	0.036
Type		Order No.	Weight per PU approx. kg

### Terminals for "Self-Protected Combination Motor Controllers (Type E)" according to UL 508 for infeed through parallel wiring with compact starters

 3RV19 28-1H	Note: UL 508 calls for "Combination Motor Controller Type E" 1-inch clearance and 2-inch creepage distance at line side. Terminal blocks are not required for use according to CSA. With size S0, these terminal blocks cannot be used in combination with 3RV19 .5 three-phase busbars. See page 4/12 for 3RV19 25-5EB for use with three-phase busbars.		
	<b>Terminal blocks type E</b> For extended clearance and creepage distances (1 and 2 inch). Mounts to line side of compact starter when parallel wiring.	<b>3RV19 28-1H</b>	0.083



# Compact Combination Starters

## 3RA6 Compact Starters

### Infeed systems for 3RA6 up to 100 A

#### ① Infeed

The three-phase infeed is available with screw connection (4-2 AWG up to 63 A or 0-2/0 AWG up to 100 A) and spring-type connection (10-3 AWG up to 63 A).

The infeed with spring-type terminal can be fitted on the left as well as on the right of an expansion module.

The infeed with screw terminal is supplied only with a 3-socket expansion module and permanently fitted on the left side.

The infeeds with screw connection enable connection of the main conductors (L1, L2, L3) either from above or from below.

The infeed with screw connection is supplied complete with 1 end cover. The infeed with spring-type connection is supplied complete with 2 end covers.

#### ② Three-socket expansion modules

The expansion module with 3 sockets for compact starters is available with screw connection and with spring-type connection.

Expansion modules enable the infeed system to be expanded and can be fitted to each other in any number.

Two expansion modules are held together with the help of 2 connecting plates and 1 expansion plug. These assembly parts are included in the scope of supply of the respective expansion module.

When the infeed system for 3RA6 is used, the compact starters (plug-in modules) are easily mounted and removed even when live.

Optional possibilities:

- PE connection on motor outgoing side
- Outfeed for external auxiliary devices
- Connection to 3RV19 infeed system
- Integration of SIRIUS motor starter protectors size S00 and S0 (using 3RA68 90-0BA adapter)

#### ③ Two-socket expansion modules

If only 2 instead of 3 additional sockets are required, then the 2-socket expansion module is the right choice. It has the same functionality as the 3-socket expansion module.

#### ④ Expansion plug

Two expansion modules can be connected together using the expansion plug. Flexible expansion of the infeed system is thus possible.

#### ⑤ PE infeeds

This module enables a PE cable to be connected.

The PE infeed can be ordered with screw connection and spring-type connection (2 AWG) and can be fitted on the right or left to the expansion block.

#### ⑥ PE expansion plug

The PE expansion plug is inserted from below and enables two PE bars to be connected.

#### ⑦ PE pick-off

The PE pick-off is available with screw connection and spring-type connection (10-8 AWG). It is snapped into the infeed system from below.

#### ⑧ Connecting plates

Two connecting plates are used to hold together 2 expansion modules.

#### ⑨ End covers

On the last expansion module of a row, the slot provided for the expansion plug can be covered by inserting the end cover.

#### ⑩ 45 mm adapters for SIRIUS motor starter protectors

SIRIUS motor starter protectors size S0 with screw connection can be fitted to the adapter, enabling them to be plugged into the infeed system.

#### Terminal blocks

Using the terminal block the 3 phases can be fed out of the system; this means that single-phase, two-phase and three-phase components can also be integrated in the system.

After the end cover is pulled out, the terminal block can be plugged onto an expansion module.

#### Expansion plug for SIRIUS 3RV19 infeed systems

After the end cover is pulled out, the expansion plug for the SIRIUS 3RV19 infeed system can be plugged onto an expansion module. It connects the infeed system for 3RA6 with the SIRIUS 3RV19 infeed system.

#### Maximum rated operational current

The following maximum rated operational currents apply for the components of the infeed system for 3RA6:

Component	Maximum rated operational current A
Infeed with screw connection 10-2/0 AWG	100
Infeed with screw connection 12-2 AWG	63
Infeed with spring-type connection 3-10 AWG	63
Expansion plug	63

In a row of several expansion modules, the maximum rated operational current after the 1st infeed module to the end of the row is 63 A.

#### Short-circuit protection data

The following short-circuit data apply for the components of the infeed system for 3RA6:

Wire AWG	Cat No.	Current (A)	Voltage (V)	Short Circuit Current (kA)	Max. Fuse (A) class RK1, RK5, K5, J, G, CC if used with manual motor controller
12-2	3RA6812 (Screw)	63	480	30	250
12-2	3RA6812 (Screw)	63	600	10	250
10-2/0	3RA6813 (Screw)	100	480	30	250
10-2/0	3RA6813 (Screw)	100	600	10	250
	3RA682	63	480	30	250
	3RA682	63	600	10	250
	3RA6830-5AC	63	480	30	250
	3RA6830-5AC	63	600	10	250
	3RA6890-1AA	63	480	30	250
	3RA6890-1AA	63	600	10	250
	3RA6890-1AB	63	480	30	250
	3RA6890-1AB	63	600	10	250
	3RA6890-0BA	25	480	30	250
	3RA6890-0BA	25	600	10	250

Notes:

1. Based on Surrounding air temperature of 40°C
2. If 3RA6 is used as a Combination Motor Controller and Infeed 3RA6813 is used, no SCPD is necessary.

# Compact Combination Starters

## 3RA6 Compact Starters

Infeed systems for 3RA6  
up to 100 A

1

2

3

4

5

6

7

8

9

10

11

12

13

14

15

16

17





### Selection and ordering data

Type	Order No.	Weight per PU approx. kg
 <p><b>Infeeds with screw connection 4-2 AWG on left with permanently fitted 3-socket expansion module with screw connection</b> on outgoing side and integrated PE bar Expansion module with 3 sockets for 3 direct-on-line starters or 1 direct-on-line starter and 1 reversing starter</p> <p>3RA68 12-8AB</p>	<p>3RA68 12-8AB</p> 	0.957
 <p><b>Infeeds with screw connection 4-2 AWG on left with permanently fitted 3-socket expansion module with spring-type connection</b> on outgoing side and integrated PE bar Expansion module with 3 sockets for 3 direct-on-line starters or 1 direct-on-line starter and 1 reversing starter</p> <p>3RA68 12-8AC</p>	<p>3RA68 12-8AC</p> 	0.990
 <p><b>Infeeds with screw connection 2/0 AWG on left with permanently fitted 3-socket expansion module with screw connection</b> on outgoing side and integrated PE bar Expansion module with 3 sockets for 3 direct-on-line starters or 1 direct-on-line starter and 1 reversing starter <b>suitable for UL duty according to UL 508 Type E</b></p> <p>3RA68 13-8AB</p>	<p>3RA68 13-8AB</p> 	1.146
 <p><b>Infeeds with screw connection 2/0 AWG on left with permanently fitted 3-socket expansion module with spring-type connection</b> on outgoing side and integrated PE bar Expansion module with 3 sockets for 3 direct-on-line starters or 1 direct-on-line starter and 1 reversing starter <b>suitable for UL duty according to UL 508 Type E</b></p> <p>3RA68 13-8AC</p>	<p>3RA68 13-8AC</p> 	1.179
 <p><b>Infeeds with spring-type connection 10-3 AWG on left or on right up to 63 A</b></p> <p>3RA68 30-5AC</p>	<p>3RA68 30-5AC</p> 	0.283

# Compact Combination Starters

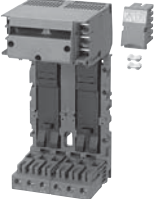
## 3RA6 Compact Starters

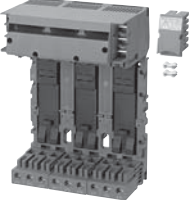
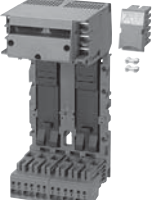
Infeed systems for 3RA6  
up to 100 A

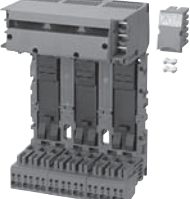
Type	Order No.	Weight per PU approx. kg
<b>Expansion modules <sup>1)</sup></b>		
 <p><b>2-socket expansion modules with screw connection</b> and integrated PE bar with 2 sockets for 2 direct-on-line starters or 1 reversing starter Expansion plug and 2 connecting plates are included in the scope of supply.</p> <p>3RA68 22-0AB</p>	<b>Screw terminals</b>  <b>3RA68 22-0AB</b>	0.505
	 <p><b>3-socket expansion modules with screw connection</b> and integrated PE bar with 3 sockets for 3 direct-on-line starters or 1 direct-on-line starter and 1 reversing starter Expansion plug and 2 connecting plates are included in the scope of supply.</p> <p>3RA68 23-0AB</p>	<b>3RA68 23-0AB</b>
 <p><b>2-socket expansion modules with spring-type connection</b> and integrated PE bar with 2 sockets for 2 direct-on-line starters or 1 reversing starter Expansion plug and 2 connecting plates are included in the scope of supply.</p> <p>3RA68 22-0AC</p>	<b>Spring-type terminals</b>  <b>3RA68 22-0AC</b>	0.527
	 <p><b>3-socket expansion modules with spring-type connection</b> and integrated PE bar with 3 sockets for 3 direct-on-line starters or 1 direct-on-line starter and 1 reversing starter Expansion plug and 2 connecting plates are included in the scope of supply.</p> <p>3RA68 23-0AC</p>	<b>3RA68 23-0AC</b>

<sup>1)</sup> The maximum rated operational current is 63 A starting from the first expansion plug to the end of the row.

# Compact Combination Starters

## 3RA6 Compact Starters

Infeed systems for 3RA6  
up to 100 A

1

2

3

4

5

6

7

8

9

10

11

12

13

14

15

16



17

Type	Order No.	Weight per PU approx. kg
<b>Accessories for infeed systems for 3RA6</b>		
 3RA68 60-6AB	<b>Screw terminals</b>  <b>PE infeeds 2 AWG with screw connection</b> 3RA68 60-6AB	0.060
	<b>Spring-type terminals</b>  <b>PE infeeds 10-3 AWG with spring-type connection</b> 3RA68 60-5AC	0.070
 3RA68 70-4AB	<b>Screw terminals</b>  <b>PE tap-offs 10-8 AWG with screw connection</b> 3RA68 70-4AB	0.019
	<b>Spring-type terminals</b>  <b>PE tap-offs 10-8 AWG with spring-type connection</b> 3RA68 70-3AC	0.017
 3RA68 90-0EA	<b>PE expansion plugs</b> Is required for each expansion module when utilizing PE. 3RA68 90-0EA	0.008
 3RA68 90-1AB	<b>Expansion plugs</b> between 2 expansion modules Is included in the scope of supply of the expansion modules. 3RA68 90-1AB	0.029
 3RA68 90-1AA	<b>Expansion plugs for SIRIUS 3RV19 infeed system</b> Connects infeed system for 3RA6 to 3RV19 infeed system 3RA68 90-1AA	0.079

# Compact Combination Starters

## 3RA6 Compact Starters

Infeed systems for 3RA6  
up to 100 A

Type	Order No.	Weight per PU approx. kg	
 <p><b>45 mm adapters for SIRIUS motor starter protectors</b> Size S0 (up to 25 A) with screw connection</p> <p>(see section 1 for MSP's)</p> <p>3RA68 90-0BA</p>	<p><b>Screw terminals</b> </p> <p><b>3RA68 90-0BA</b></p>	0.152	
	<p><b>Spring-type terminals</b> </p> <p><b>3RV19 17-5D</b></p>	0.050	
 <p><b>Terminal blocks</b> With spring-type connection for integration of single-phase, two-phase and three-phase external components</p> <p>3RV19 17-5D</p>			
Version	Size	Order No.	Weight per PU approx. kg
<b>Tools for spring-type terminals</b>			
 <p><b>Screwdrivers</b> 3.5 mm x 0.5 mm, suitable for a max. conductor cross-section of 2.5 mm<sup>2</sup></p> <p>8WA2 803</p>	<p><b>Spring-type terminals</b> </p> <p><b>8WA2 803</b></p>	0.024	
	<p>Length approx. 175 mm; green</p>		