

SIEMENS

SEBKR1V6

Installation Instructions for Service Entrance Barrier Kits for BL / BQD / xGB / 3VA41 Main Breakers Outside Unit Space in an RP1 Panelboard



⚠ DANGER

Hazardous voltage. Will cause death or serious injury.

Keep out. Qualified personnel only. Disconnect and lock off all power before working on this equipment.

This instruction sheet is to support the field installation of a Service Entrance Barrier Kit in a Siemens Revised P1 Panelboard. This is for a Type BL, BQD, xGB or 3VA41 Main Breaker outside of unit space. This covers both single & three phase panels, either top or bottom fed.

1. Lock off ALL power supplying this equipment before working on it.
2. Remove the panelboard front cover and deadfront.
3. Identify the deadfront support closest to the service terminals of the service disconnect: On top-fed units, the service terminals are in the upper left corner; on bottom-fed units, the service terminals are in the lower right corner.
4. If the application involves an xGB or BQD breaker with accessory, remove the tab from the barrier on the accessory side. The barrier is perforated at each tab on each side. Remove by bending it back and forth and then tearing it off. (All other applications, skip to the next step.)
5. Position the Barrier Support Assembly (Item 1) by carefully sliding the barrier over the line end of the breaker, with the Barrier Support Assembly metal support bracket landing on the base rail, near the deadfront support. If the breaker has a shunt trip installed, ensure the barrier flap on that side is positioned between the shunt trip and breaker bodies.
6. Secure the Barrier Support Assembly to the base rail using the hole nearest the deadfront support bracket. Tighten the screw (Item 2) from this kit to 30 lb-in.
7. Before energizing the panel, ensure that ALL connections have been properly torqued, that the barrier is in place and secure, that the deadfront is installed and that all fillers are in place.

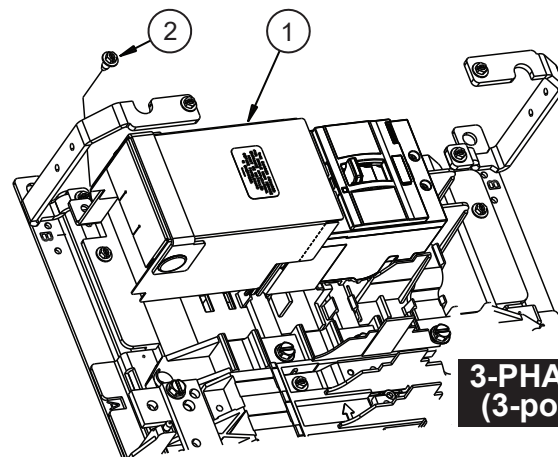
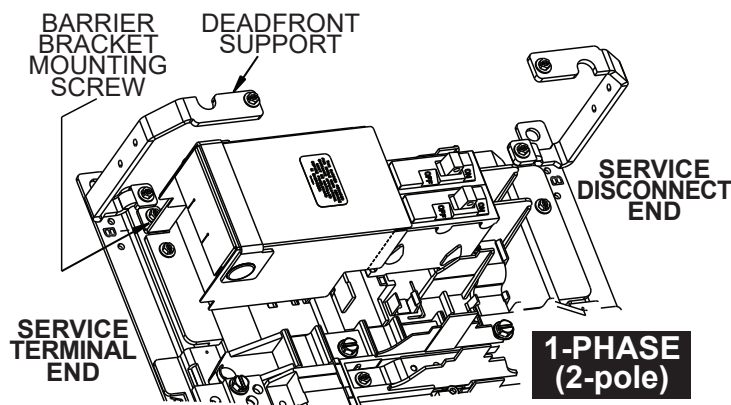

Item 1: Barrier Support Assembly, Pre-assembled (as shipped)

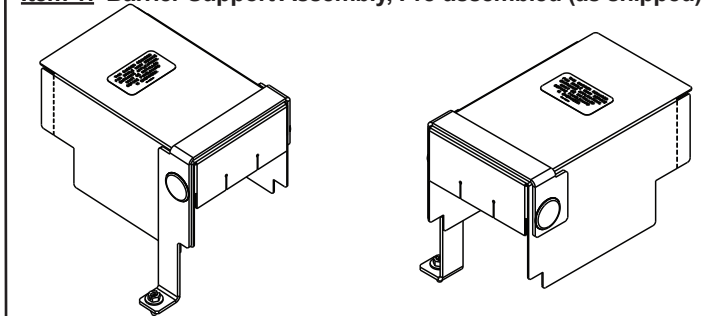

THIS KIT CONTAINS THE FOLLOWING ITEMS:

ITEM	DESCRIPTION	QTY
1	Barrier Support Assembly	1
2	#10-24 x 7/16" SHWHSW Screw	1

These instructions do not purport to cover all details or variations in equipment, or to provide for every possible contingency to be met in connection with installation, operation or maintenance. Should further information be desired or should particular problems arise, which are not covered sufficiently for the purchaser's purposes, the matter should be referred to the local Siemens sales office. The contents of this Instruction manual shall not become part of or modify any prior or existing agreement, commitment or relationship. The sales contract contains the entire obligation of Siemens. The warranty contained in the contract between the parties is the sole warranty of Siemens. Any statements contained herein do not create new warranties or modify the existing warranty.

Trademarks-Unless otherwise noted, all names identified by ® are registered trademarks of Siemens AG or Siemens Industry, Inc. The remaining trademarks in this publication may be trademarks whose use by third parties for their own purposes could violate the rights of the owner.